



Service Repair Manual

Models

325D 325D L and 325D LN
Excavator

Tool	Part Number	Part Description	Qty
A	1P-2420	Transmission Repair Stand	1
B	138-7573	Link Bracket	2
C	1P-1863	Retaining Ring Pliers	1
D	138-7575	Link Bracket	3
E	4C-8359	Eyebolt	2
F	138-7574	Link Bracket	2
G	138-7576	Link Bracket	2

Start By:

- a. Start by removing the final drive. Refer to Disassembly and Assembly, "Final Drive - Remove".

Note: Cleanliness is an important factor. Before the disassembly procedure, the exterior of the component should be thoroughly cleaned. This will prevent dirt from entering the internal mechanism.

1. Put an alignment mark across the sections of the final drive for assembly purposes. The parts must be reinstalled to the original locations.



Illustration 1

g00892878

2. Use Tooling (G) and a suitable lifting device to position the final drive assembly onto Tooling (A). The weight of the final drive assembly is approximately 550 kg (1200 lb).
3. Remove bolts (1).

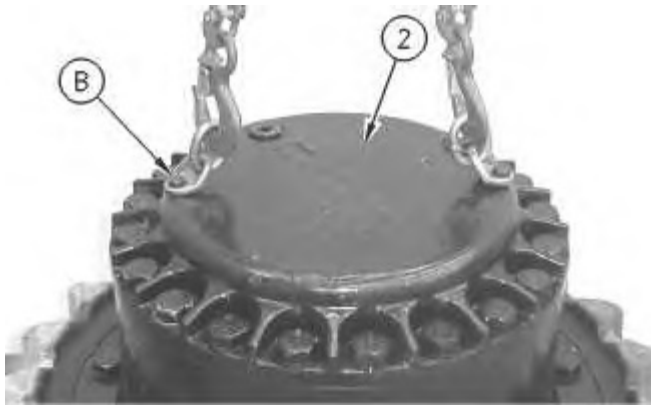

Illustration 2

g00892883

4. Use Tooling (B) and a suitable lifting device to remove cover (2). The weight of cover (2) is approximately 32 kg (70 lb).

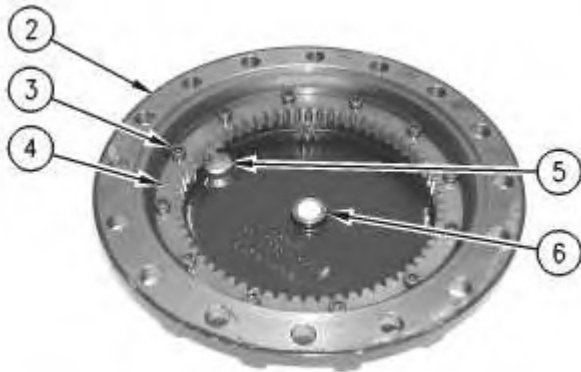

Illustration 3

g00892888

5. Remove bolts (3) and gear (4). Check plate (6). Replace plate (6) if plate (6) is worn. Remove plugs (5) from cover (2).



Illustration 4

g00892906

6. Remove O-ring seals (7) from plugs (5).

<https://www.ebooklibonline.com>

Hello dear friend!

Thank you very much for reading.

Enter the link into your browser.

The full manual is available for immediate download.

<https://www.ebooklibonline.com>



Illustration 5

g00892930

7. Remove gear (8) and spacer (9).



Illustration 6

g00892965

8. Use Tooling (C) to remove retaining ring (10). Remove washer (11) and gear (12). Remove bearing assembly (13) and washer (14).
9. Repeat Step 8 for the other two gear assemblies.



Illustration 7

g00892968

10. Remove retaining ring (15).

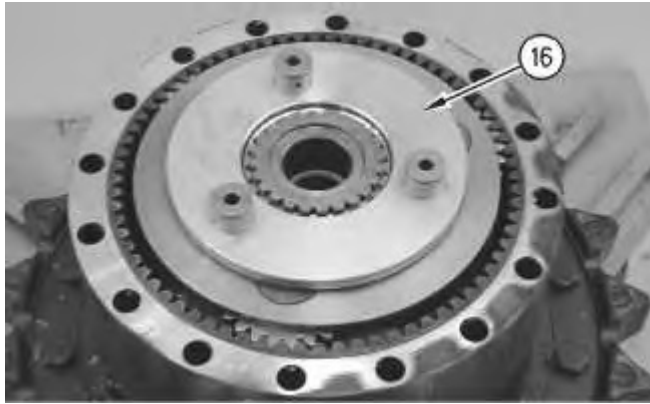

Illustration 8

g00892975

11. Remove carrier assembly (16).

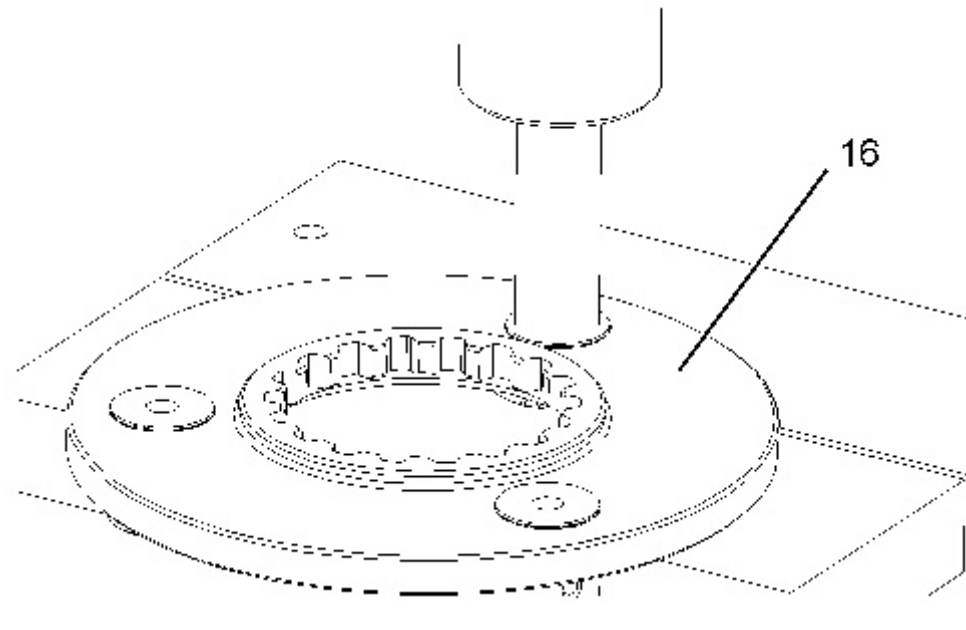

Illustration 9

g01389804

12. Use a suitable press to remove the shafts from carrier assembly (16).

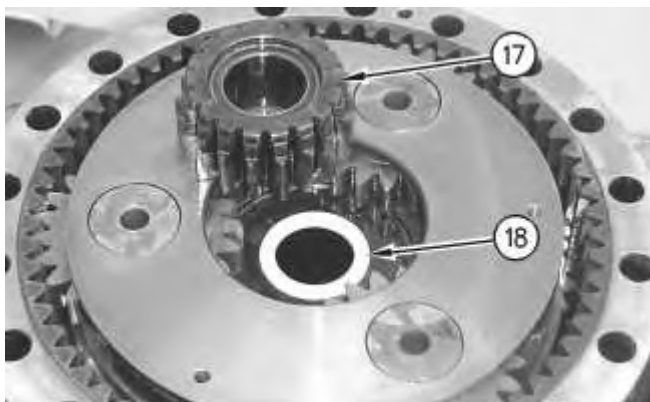

Illustration 10

g00892977

13. Remove gear (17) and spacer (18).

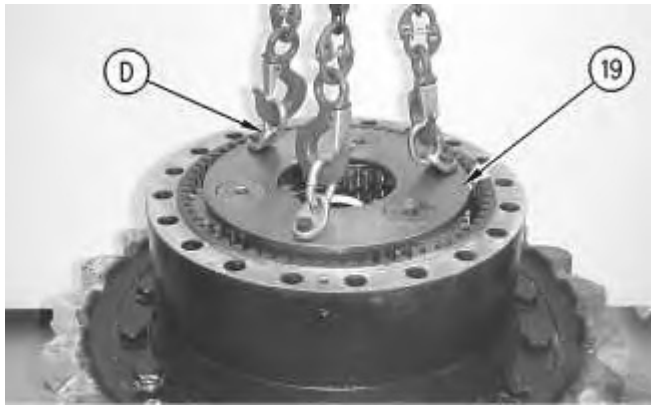

Illustration 11

g00892997

14. Use Tooling (D) and a suitable lifting device to remove planetary carrier (19). The weight of planetary carrier (19) is approximately 48 kg (105 lb).

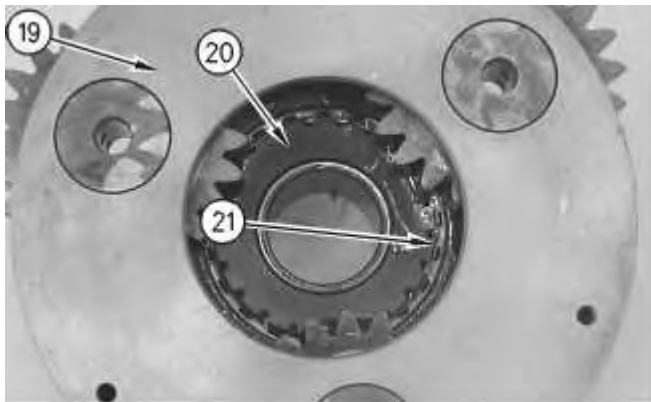

Illustration 12

g00893019

15. Remove retaining ring (21). Lift planetary carrier (19) off sun gear (20).



Illustration 13

g00896860

16. Drive spring pin (23) into planetary shaft (22).



Illustration 14

g00893043

17. Remove planetary shaft (22). Use a suitable punch to remove spring pin (23) from planetary shaft (22).

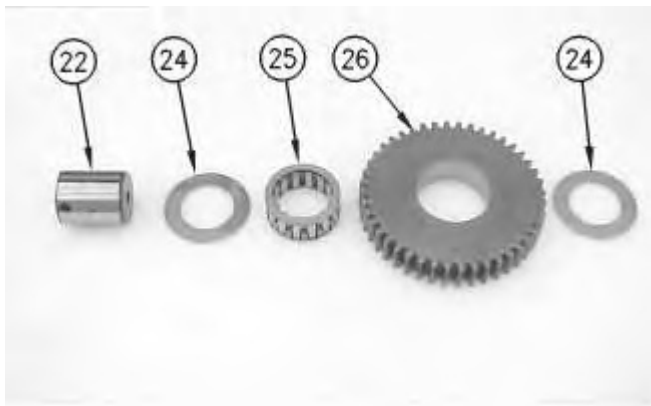

Illustration 15

g00896863

18. Remove washers (24) and bearing (25) from planetary gear (26).
19. Repeat Steps 16 through 18 for the other two planetary gears.

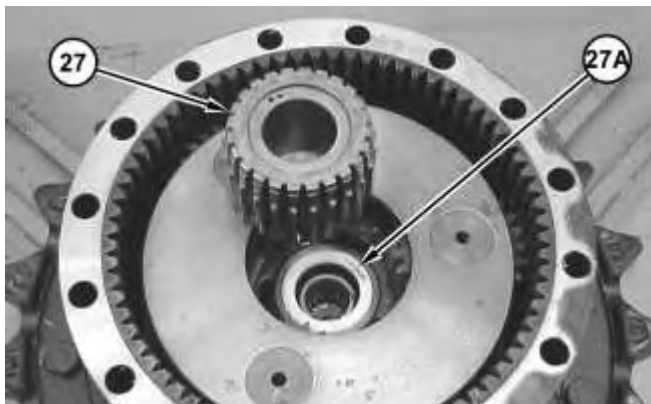

Illustration 16

g01842853

20. Remove gear (27). Remove spacer (27A).



Illustration 17

g01842974

21. Use two people to remove carrier assembly (28). The weight of carrier assembly (28) is approximately 38 kg (85 lb).



Illustration 18

g01843140

22. Drive spring pin (30) into shaft (29).



Illustration 19

g00893658

23. Remove shaft (29). Use a suitable punch to remove spring pin (30) from shaft (29).
-

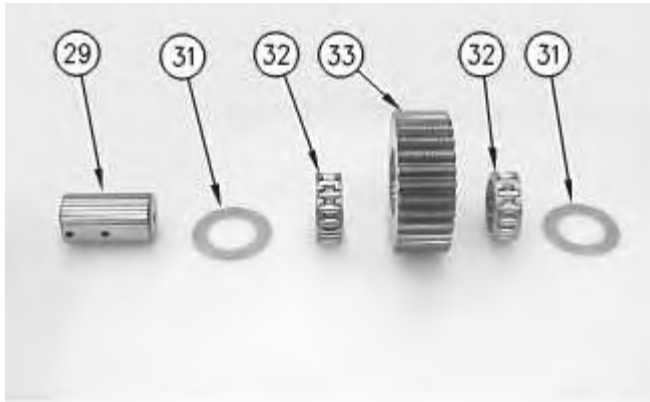

Illustration 20

g00893674

24. Remove washers (31) and bearings (32) from planetary gear (33).
25. Repeat Steps 22 through 24 for the other three planetary gears.



Illustration 21

g01208300

26. Fasten Tooling (E) and a suitable lifting device to ring gear (34), as shown. Remove ring gear (34) from sprocket housing (35). The weight of ring gear (34) is approximately 66 kg (146 lb).



Illustration 22

g01208542

27. Remove O-ring seal (36) from sprocket housing (35).

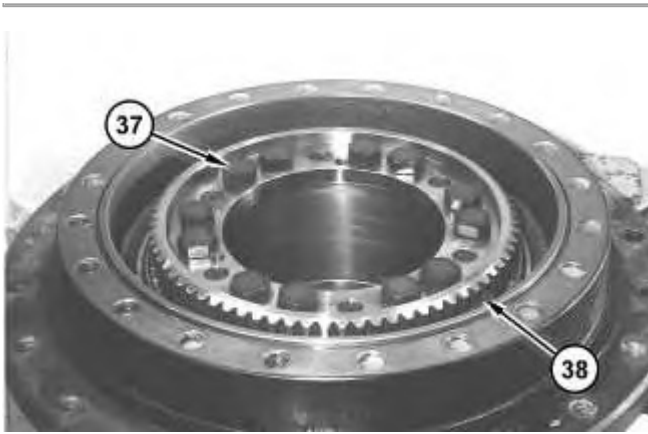

Illustration 23

g01208553

28. Remove bolts (37) from coupling gear (38).

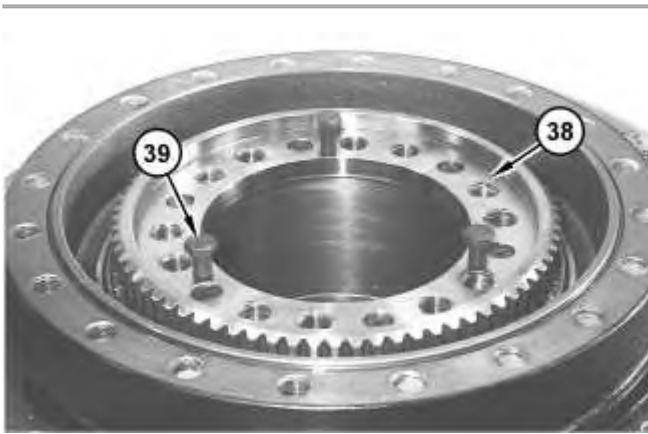

Illustration 24

g01208572

29. Install suitable forcing bolts (39) in coupling gear (38). Tighten the forcing bolts evenly in order to loosen coupling gear (38). Remove the coupling gear from the motor housing.



Illustration 25

g01208578



Illustration 26

g01208625

30. Remove shims (40) from the motor housing.

Note: Inner cones and outer bearing cones (42) are a slip fit on the motor housing. While you remove sprocket housing (35) from the motor housing, inner bearing cone (42) may stay with the sprocket housing or the inner bearing cone may stay on the motor housing.

31. Fasten Tooling (F) and a suitable lifting device to sprocket housing (35). Separate the sprocket housing from the motor housing. The weight of sprocket housing (35) is approximately 109 kg (240 lb).



Illustration 27

g01208626

32. Remove the locating pins from the motor housing.
 33. Remove Duo-Cone seal (41) from the motor housing.
 34. If inner bearing cone (42) remained on the motor housing, then remove the inner bearing cone.
-



Illustration 28

g01208633

35. Remove Duo-Cone seal (43) from the sprocket housing.
36. If inner bearing cone (42) remained on the sprocket housing, then remove the inner bearing cone.
37. Remove the bearing cups from the sprocket housing.

[Previous Screen](#)

Product: EXCAVATOR

Model: 325D EXCAVATOR PKE

Configuration: 325D L & LN Excavator PKE00001-UP (MACHINE) POWERED BY C7 Engine

Disassembly and Assembly

324D, 325D, 326D and 329D Excavators and 329D MHPU Mobile Hydraulic Power Unit Machine Systems

Media Number -REN8646-22

Publication Date -01/02/2015

Date Updated -12/09/2018

i03949150

Final Drive - Assemble

SMCS - 4050-016

S/N - A3R1-UP

S/N - AZP1-UP

S/N - BFC1-UP

S/N - BYS1-UP

S/N - CZF1-UP

S/N - DBH1-UP

S/N - DJF1-UP

S/N - DTZ1-UP

S/N - EBM1-UP

S/N - EJC1-UP

S/N - GBR1-UP

S/N - GPB1-UP

S/N - GPK1-UP

S/N - JAT1-UP

S/N - JHJ1-UP

S/N - JG1-UP

S/N - JZR1-UP

S/N - KBE1-UP

S/N - LAB1-UP

S/N - LAL1-UP

S/N - MCL1-UP

S/N - MNB1-UP

S/N - MND1-UP

S/N - NAC1-UP

S/N - PJM1-UP

S/N - PKE1-UP

S/N - PYT1-UP

S/N - RSK1-UP

S/N - SCR1-UP

S/N - SYM1-UP

S/N - T2D1-UP

S/N - T2S1-UP

S/N - TPM1-UP

S/N - TRH1-UP

S/N - TSN1-UP

S/N - TZL1-UP

S/N - XDB1-UP

S/N - YFW1-UP

Assembly Procedure

Table 1

Required Tools			
Tool	Part Number	Part Description	Qty

A	1P-2420	Transmission Repair Stand	1
B	138-7573	Link Bracket	2
D	138-7574	Link Bracket	2
G	126-3994	Duo-Cone Seal Installer	1
H	5P-3931	Anti-Seize Compound	
F	1U-8846	Gasket Sealant	

Note: Cleanliness is an important factor. Before assembly, all parts should be cleaned in cleaning fluid. Allow the parts to air dry. Wiping cloths or rags should not be used to dry parts. Lint may be deposited on the parts which may cause later trouble. Inspect all parts. If any parts are worn or damaged, use new parts for replacement. All disassembly and all assembly procedures must be performed on a clean work surface and in a clean hydraulic area. Keep cleaned parts covered and protected at all times.

Note: O-rings, gaskets, and seals should always be replaced. A used O-ring may not have the same sealing properties as a new O-ring. Use **1U-6396** O-Ring Assembly Compound during the assembly procedure.

Note: Apply a light film of hydraulic oil to all components before assembly.

1. Install the final drive sprocket if the sprocket was removed from the main housing.
2. Refer to Disassembly and Assembly, "Final Drive Sprocket - Remove and Install".

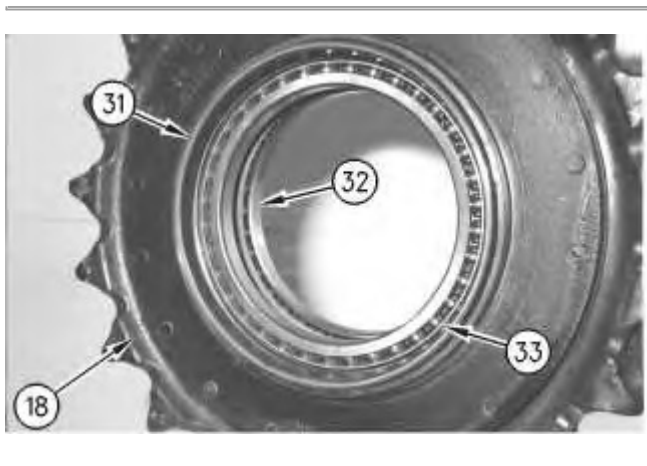

Illustration 1

g00708215

3. Apply Tooling (H) to the outer diameter of the bearings.
4. Install bearings (32) and (33) in main housing (18) with a suitable press.
5. Make sure that bearing (32) and bearing (33) contact the counterbore in the main housing.
6. Use the following procedure to preload the bearings and determine the correct thickness of shims.

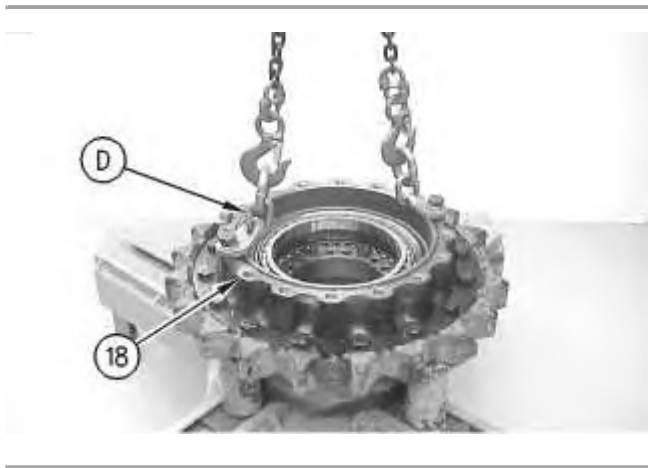

Illustration 2

g00713058

- a. Fasten Tooling (D) and a suitable lifting device to main housing (18) . Install the main housing on the motor housing.
- b. Put the main housing and the motor housing in a suitable press.

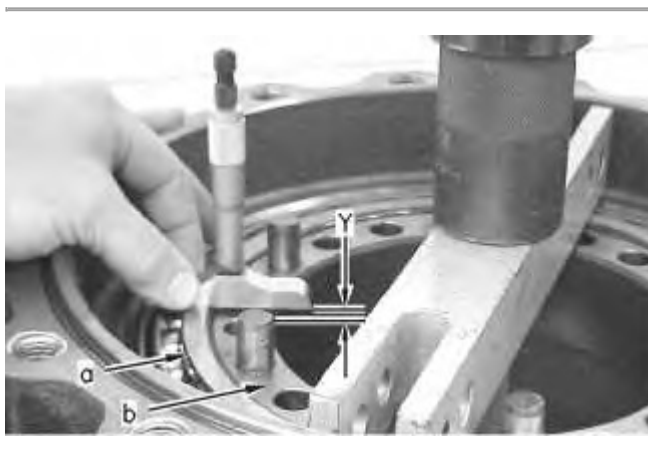

Illustration 3

g00709278

- (a) Bearing surface
 - (b) Housing surface
- c. Use a suitable press and a spacer in order to apply a load of 4000 kg (8818.5 lb) on the bearings. Rotate the housing in order to seat the bearings.
 - d. Reduce the load on the bearings to 1000 ± 100 kg (2204.6 ± 220.5 lb).
 - e. Use a depth micrometer in order to measure the step length between the bearing surface and the housing surface. Take measurements at several different locations around the housing. Compute the average of the measured dimensions and record the number. Call this Dimension (Y) .
-

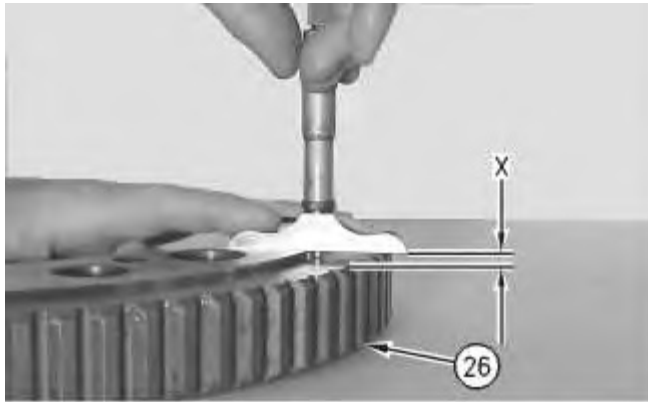

Illustration 4

g00709276

- f. Use a depth micrometer in order to measure the step length of the coupling gear (26) . Take measurements at several different locations around the gear. Compute the average of the measured dimensions and record the number. Call this Dimension (X) .
 - g. The thickness of the shims is equal to $(X - Y) \pm 0.05$ mm (0.002 inch).
- Note:** Use no more than two shims. If two shims are required, install the thinner shim next to the gear.
- h. Remove the main housing from the motor housing.

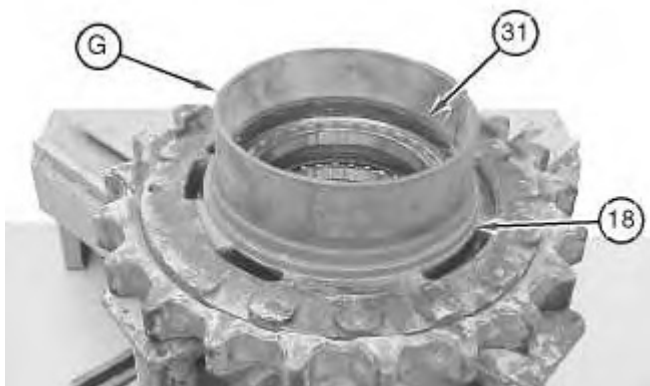

Illustration 5

g01021370

7. Use Tooling (G) in order to install Duo-Cone seal (31) in main housing (18) . Refer to Disassembly and Assembly, "Duo-Cone Conventional Seals - Install".

Note: The rubber seals and all surfaces that contact the seals must be clean and dry. After installation of the seals, put clean SAE 30 oil on the contact surfaces of the metal seals.



Illustration 6

g01021371

8. Use Tooling (G) in order to install Duo-Cone seal (29) in motor housing (28) .

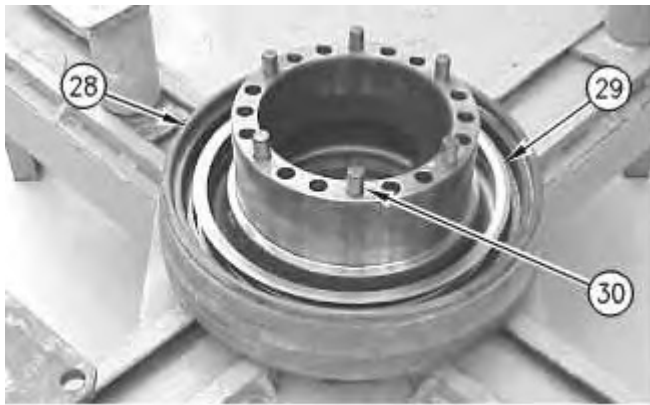

Illustration 7

g00708214

9. Apply Tooling (H) to the surfaces that contact pins (30) .
10. Install alignment pins (30) .

Note: Do not damage the Duo-Cone seals in the main housing or in the motor housing during the assembly of the two components. After installation of the main housing on the motor housing, there will be a small gap between the components. The gap is caused by the Duo-Cone seals. This gap will be eliminated during installation of gear (26) .

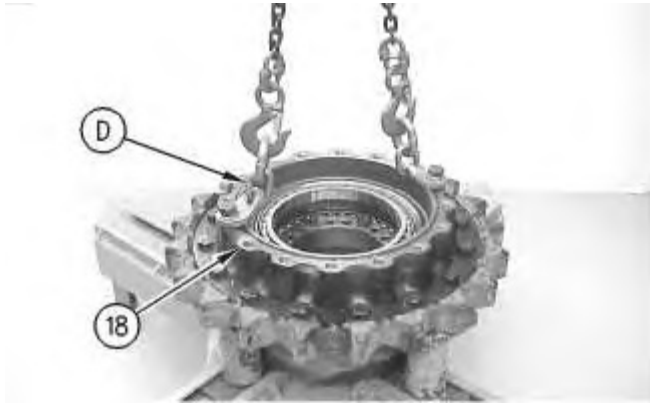

Illustration 8

g00713058

11. Fasten Tooling (D) and a suitable lifting device to main housing (18) . Install the main housing on the motor housing.

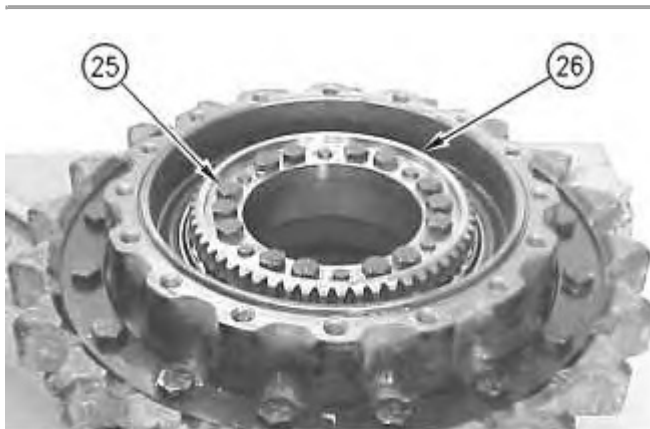

Illustration 9

g00708211

12. Install shims (27) that were determined in Step 6.g in the main housing.

Note: If two shims are required, install the thinner shim next to the gear.



13. Install gear (26) .
14. Install bolts (25) in gear (26) . Install the bolts in an even pattern until the gear is seated against the bearing. Tighten bolts (25) in a crisscross pattern.

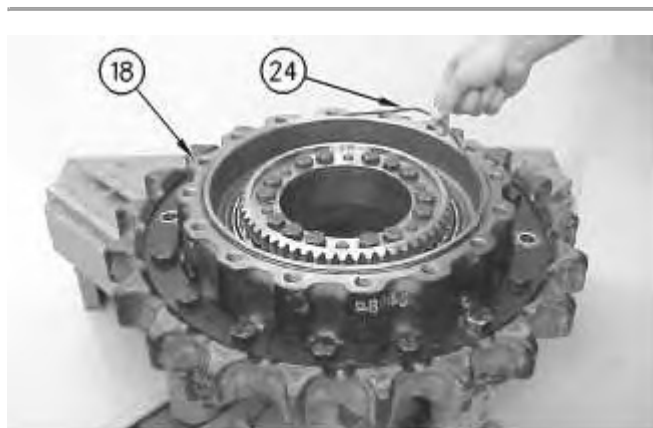

Illustration 11

15. Install O-ring seal (24) to main housing (18) .



Illustration 12

16. Assemble carrier assembly (15) , as follows.
-

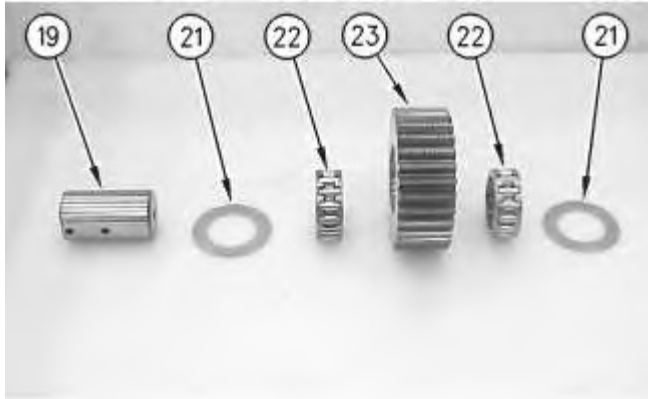

Illustration 13

g00708220

- a. Install bearings (22) in planetary gear (23) .
- b. Install thrust washers (21) and planetary gear (23) in the carrier assembly.
- c. Use a deburring tool in order to remove the metal burr from the openings in the carrier. Install planetary shaft (19) in the carrier assembly.
- d. Drive spring pin (20) into planetary shaft (19) with a hammer and a punch.

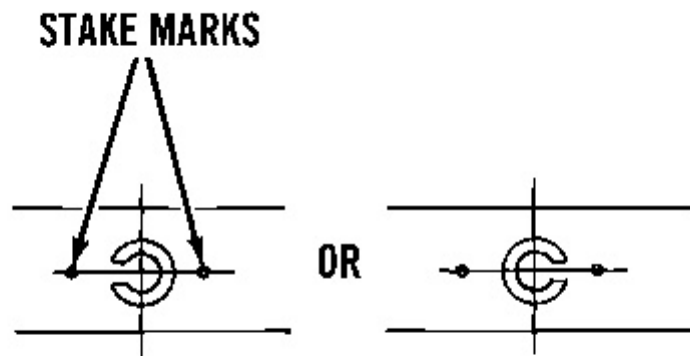

Illustration 14

g00513451

- e. Orient the split in spring pin (20) vertically to the carrier. Align the split in the spring pin to the top or to the bottom. Make a stake mark on each side of the spring pin hole in the carrier. Each stake mark should be approximately 1.50 mm (0.059 inch) from the outside diameter of the spring pin hole.
17. Repeat Steps 16.a through 16.e in order to install the remaining planetary gears in the carrier assembly.

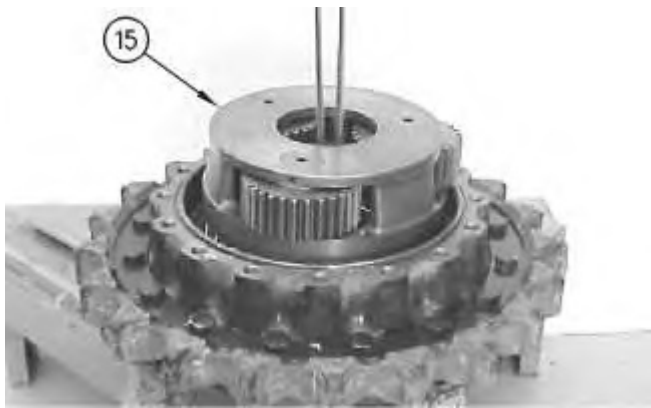

Illustration 15

g00708172

18. Install a lifting sling through the middle of carrier assembly (15) . Fasten a 12.7 mm (0.50 inch) shackle to the suitable lifting device.
19. Install carrier assembly (15) on the final drive. The weight of carrier assembly (15) is approximately 39 kg (85 lb).
20. Remove the shackle and the suitable lifting device.



Illustration 16

g00713148

21. Apply Tooling (F) to the mating surface of ring gear (17b) .
 22. Install ring gear (17a) on ring gear (17b) .
-

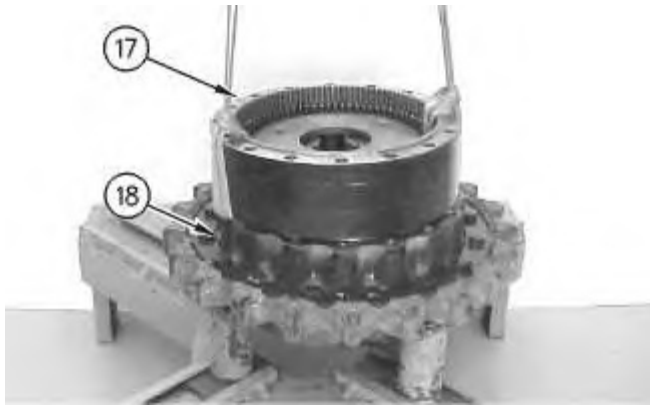

Illustration 17

g00708184

23. Fasten a suitable lifting device to ring gears (17) , as shown. Install the ring gears to main housing (18) . The weight of ring gears (17) is approximately 45 kg (100 lb).

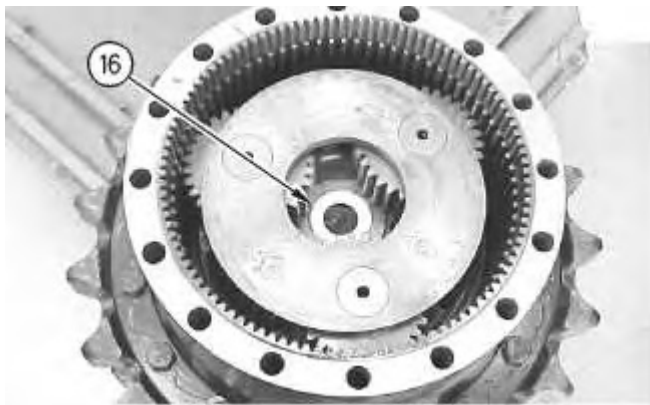

Illustration 18

g00708325

24. Install spacer (16) in the carrier assembly.

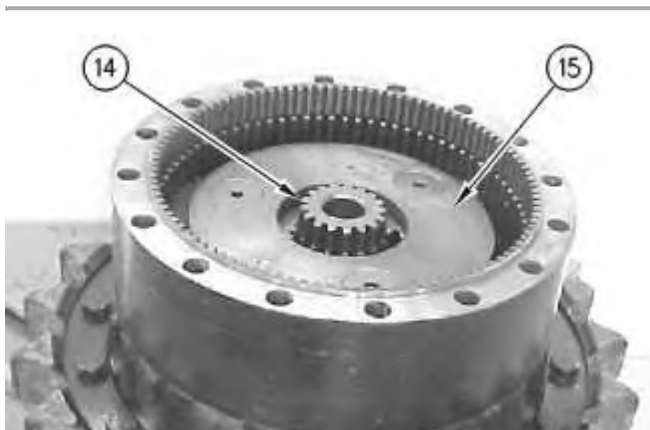

Illustration 19

g00708162

25. Install sun gear (14) in carrier assembly (15) .



Illustration 20

g01304883

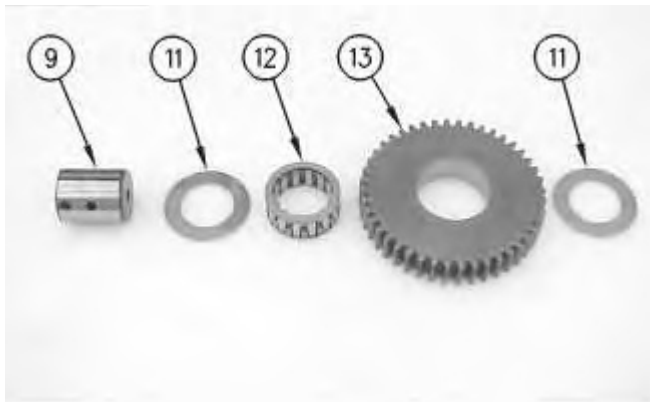

Illustration 21

g00708218

26. Assemble carrier assembly (7) , as follows.

- a. Install bearing (12) in planetary gear (13) .
 - b. Install thrust washers (11) and planetary gear (13) in the carrier assembly.
 - c. Install planetary shaft (9) in the carrier assembly.
 - d. Drive spring pin (10) into planetary shaft (9) with a hammer and a punch.
-

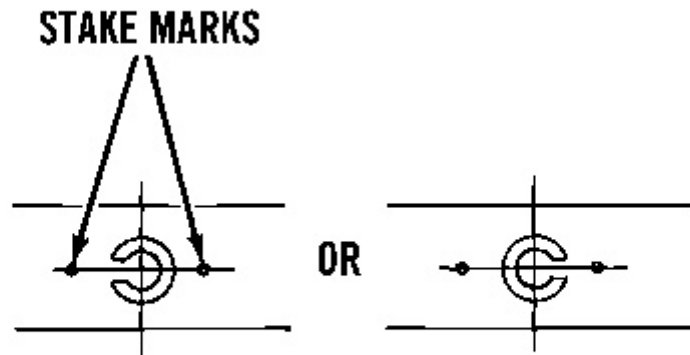

Illustration 22

g00513451

- e. Orient the split in spring pin (10) vertically to the carrier. Align the split in the spring pin to the top or to the bottom. Make a stake mark on each side of the spring pin hole in the carrier. Each stake mark should be approximately 1.50 mm (0.059 inch) from the outside diameter of the spring pin hole.
27. Repeat Steps 26.a through 26.e in order to install the remaining planetary gears in the carrier assembly.

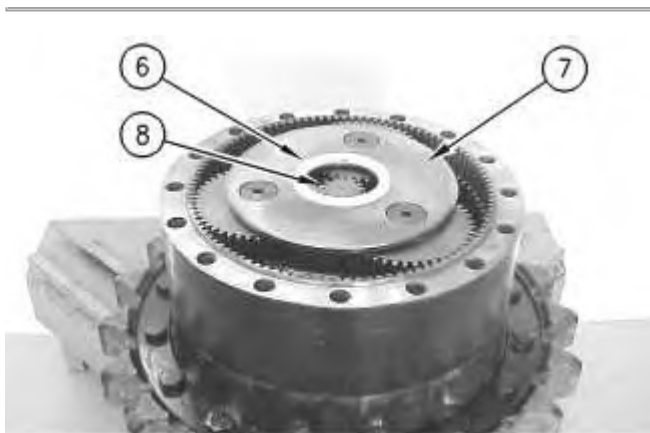

Illustration 23

g00708092

28. Install carrier assembly (7) in the ring gear. The weight of carrier assembly (7) is approximately 14 kg (30 lb).
 29. Install sun gear (8) in carrier assembly (7) .
 30. Install spacer (6) in carrier assembly (7) .
-



Suggest:

If the above button click is invalid.

Please download this document

first, and then click the above link

to download the complete manual.

Thank you so much for reading



Illustration 24

g00708235

31. Install new O-ring seals (5) on plugs (4) that were in the cover.

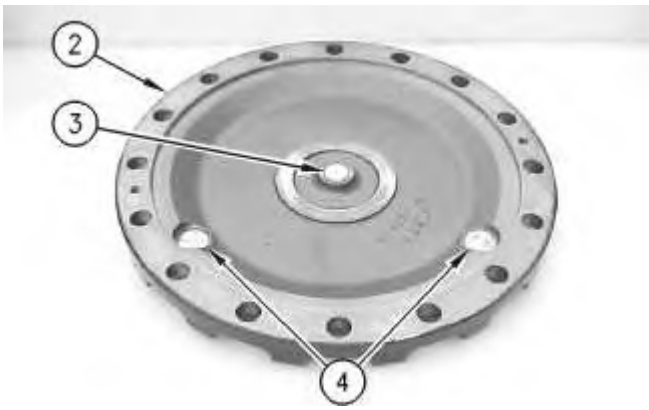
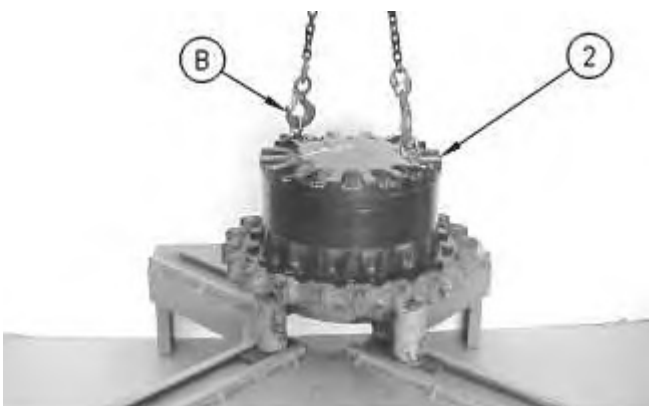

Illustration 25

g00708091

32. Install plugs (4) in cover (2) . Tighten plugs (4) to a torque of $80 \pm 10 \text{ N}\cdot\text{m}$ ($59 \pm 7 \text{ lb ft}$).
33. Install thrust plate (3) in cover (2) .
34. Apply Tooling (F) to the mating surface of the ring gear.



<https://www.ebooklibonline.com>

Hello dear friend!

Thank you very much for reading.

Enter the link into your browser.

The full manual is available for immediate download.

<https://www.ebooklibonline.com>