



Service Repair Manual

Models

323E L, 323E LN, 323E SA
Excavator

1. Install final drive (4) in the reverse order of removal.
 - a. Before assembly, remove compound, oil, and dust from female threads, then apply Tooling (B) to the threads of bolts (6).
 - b. Tighten bolts (6) in an alternating sequence to a torque of 150 ± 25 N·m (111 ± 18 lb ft). Turn an additional angle of 55 ± 5 degrees. Refer to Service Magazine , M0083843 , "An Improved Bolt Tightening Procedure for the Critical Joints Is Now Used on all Excavators" for more detailed information.
 - c. Tighten bolts (3) to a torque of 80 ± 8 N·m (59 ± 6 lb ft).

Disassembly Procedure

Table 3

| Required Tools | | | |
|----------------|-------------|---------------------------|-----|
| Tool | Part Number | Part Description | Qty |
| A | 1P-2420 | Transmission Repair Stand | 1 |
| B | 439-3938 | Link Bracket | 2 |
| C | 154-6181 | Forcing Bolt | 1 |
| D | 439-3939 | Link Bracket As | 2 |
| E | 5F-7366 | Forcing Bolt | 1 |
| | 1P-5546 | Crossblock | 1 |
| | 1U-9889 | Crossblock | 1 |
| | 1P-0520 | Driver Group | 1 |
| | 6V-7888 | Puller Leg | 2 |
| | 1H-3112 | Puller Assembly | 1 |
| | 1P-5551 | Adjustable Screw Assembly | 1 |
| F | 1U-8846 | Gasket Sealant | 1 |

Start By:

- a. Remove the final drive.
 1. Put an alignment mark across the sections of the final drive for assembly purposes. The parts must be reinstalled in the original locations.
-



Illustration 6

g00708089

2. Fasten the final drive to Tooling (A), as shown. The combined weight of the final drive and final drive sprocket is approximately 312 kg (688 lb).
3. Remove bolts (1) and the washers that hold the cover in position.

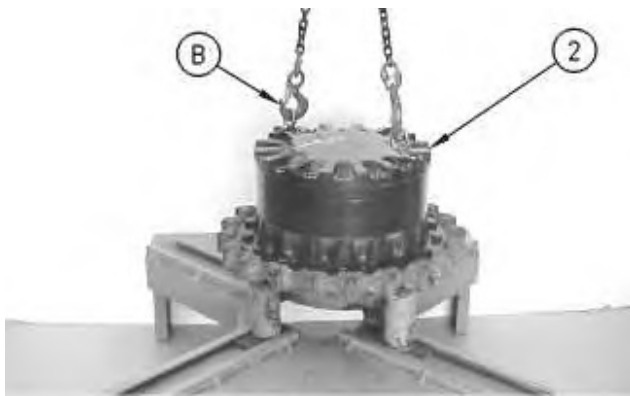

Illustration 7

g00708090

4. Remove the setscrews from the cover. Fasten Tooling (B) and a suitable lifting device to cover (2), as shown. The weight of cover (2) is approximately 32 kg (70 lb). Remove cover (2).

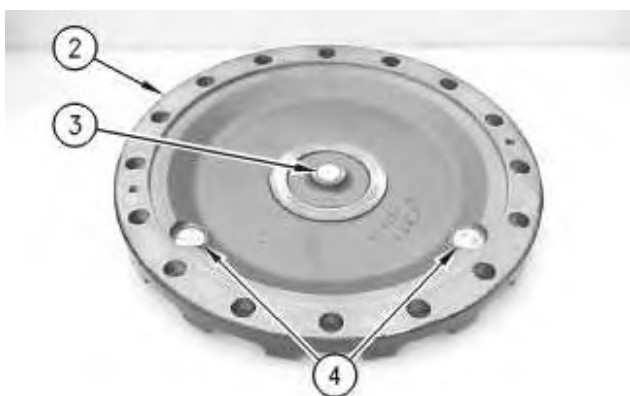

Illustration 8

g00708091

5. Remove thrust plate (3) from cover (2).

<https://www.ebooklibonline.com>

Hello dear friend!

Thank you very much for reading.

Enter the link into your browser.

The full manual is available for immediate download.

<https://www.ebooklibonline.com>

6. Remove plugs (4) from cover (2).

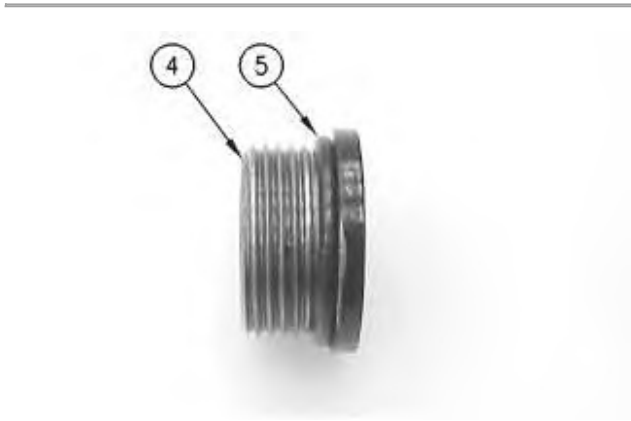

Illustration 9

g00708235

7. Remove O-ring seals (5) from both plugs (4) that were in the cover.

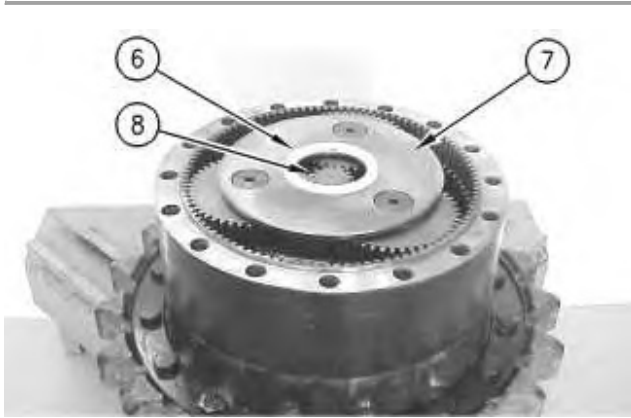

Illustration 10

g00708092

8. Remove spacer (6) from carrier assembly (7).

9. Remove sun gear (8) from carrier assembly (7).

10. Remove carrier assembly (7) by lifting the carrier assembly straight up. The weight of carrier assembly (7) is approximately 14 kg (30 lb).

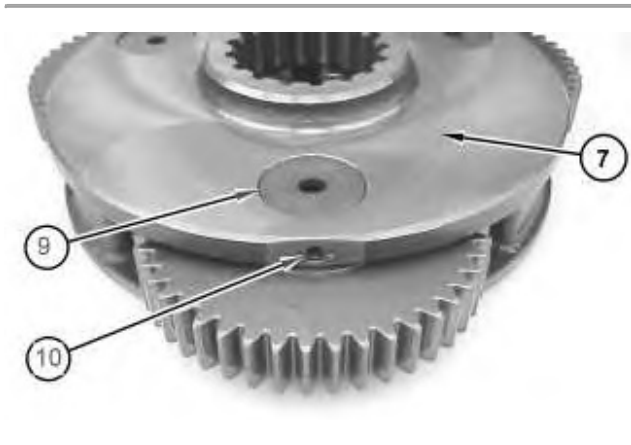

Illustration 11

g01304883

11. Disassemble carrier assembly (7), as follows.

- a. Drive spring pin (10) into planetary shaft (9) with a hammer and a punch.



Illustration 12

g00708144

- b. Remove planetary shaft (9) with spring pin (10) from the carrier assembly.
- c. Remove spring pin (10) from planetary shaft (9) with a hammer and a punch.

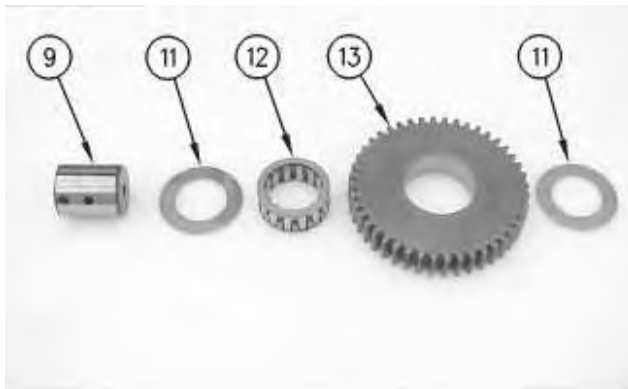

Illustration 13

g00708218

- d. Remove thrust washers (11) and planetary gear (13) from the carrier assembly.
 - e. Remove bearing (12) from planetary gear (13).
12. Repeat Steps 11.a through 11.e to remove the remaining planetary gears from the carrier assembly.
-

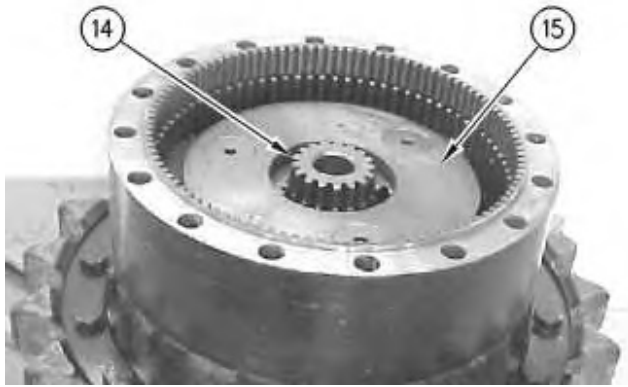

Illustration 14

g00708162

13. Remove sun gear (14) from carrier assembly (15).

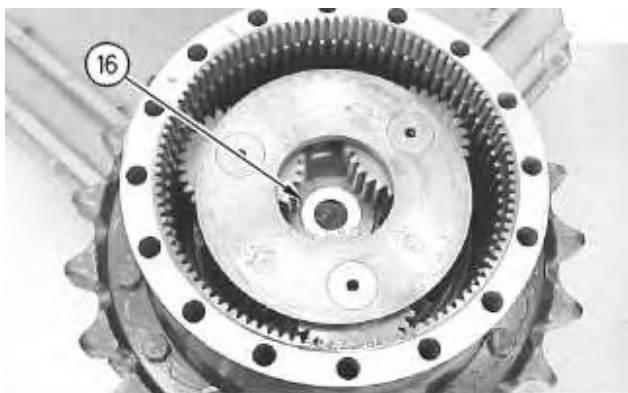

Illustration 15

g00708325

14. Remove spacer (16).

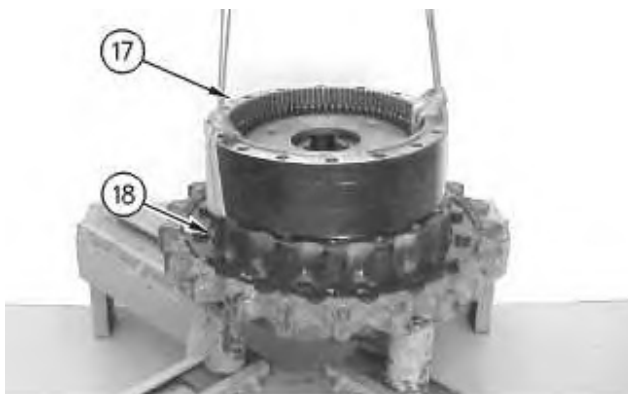

Illustration 16

g00708184

Note: It will be necessary to pry ring gears (17) away from main housing (18) to install the lifting slings.

15. Fasten a suitable lifting device to ring gears (17), as shown. Remove the ring gears from main housing (18). The weight of ring gears (17) is approximately 45 kg (100 lb).



Illustration 17

g00708360

16. Use a screwdriver or a chisel to separate the two ring gears (17).

Note: The two ring gears are held together with Tooling (F). It may be necessary to heat the ring gears to soften the sealant. Do not heat over 135 °C (275 °F) for more than thirty minutes.

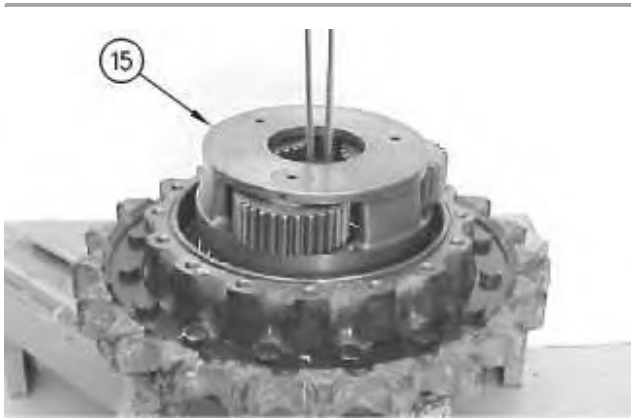

Illustration 18

g00708172

17. Position a 12.7 mm (0.50 inch) shackle under carrier assembly (15).
18. Fasten a suitable lifting device to the shackle.
19. Slowly lift carrier assembly (15) from the final drive. The weight of carrier assembly (15) is approximately 39 kg (85 lb).
20. Disassemble carrier assembly (15), as follows.



Illustration 19

g00708175

- a. Drive spring pin (20) into planetary shaft (19) with a hammer and a punch.



Illustration 20

g00708370

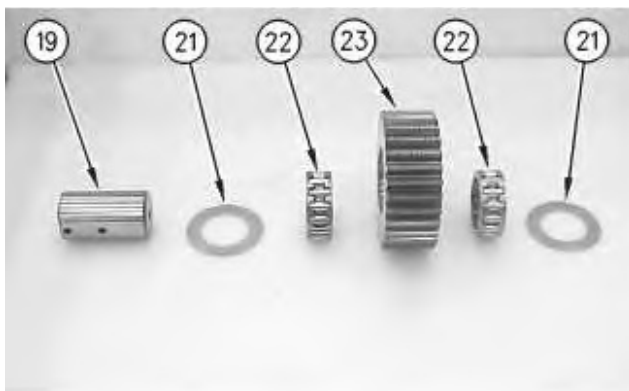

Illustration 21

g00708220

- b. Remove planetary shaft (19) with spring pin (20) from the carrier assembly.
- c. Remove spring pin (20) from planetary shaft (19) with a hammer and a punch.
- d. Remove thrust washers (21) and planetary gear (23) from the carrier assembly.
- e. Remove bearings (22) from planetary gear (23).

21. Repeat Steps 20.a through 20.e to remove the remaining planetary gears from the carrier.

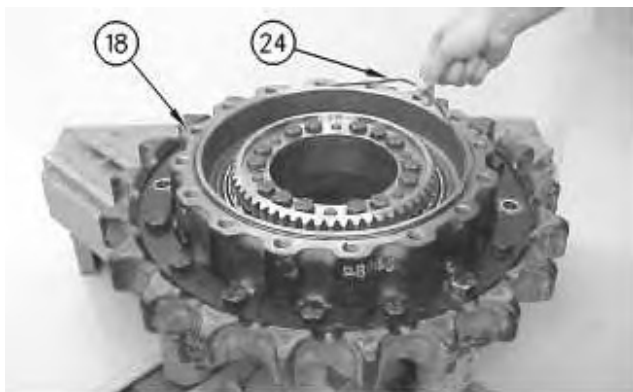

Illustration 22

g00708186

22. Remove O-ring seal (24) from main housing (18).



Illustration 23

g00708187

23. Remove bolts (25) from gear (26).

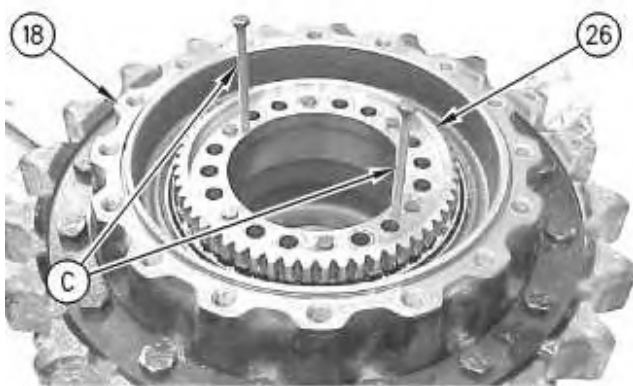

Illustration 24

g00708202

24. Use Tooling (C) to remove gear (26) from main housing (18).

Note: The motor housing will separate from the main housing (18) once gear (26) is removed. Make sure that the motor housing is supported.



Illustration 25

g00708211

25. Remove shims (27) from the main housing.

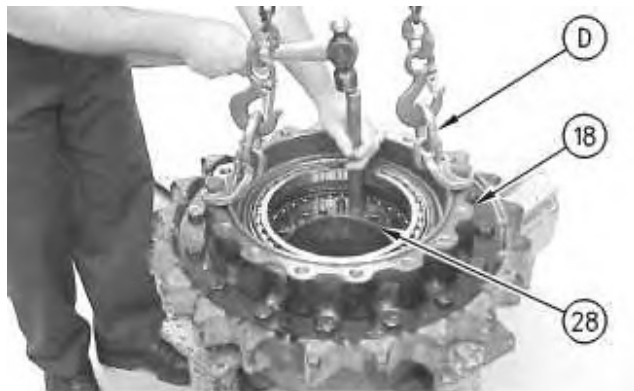

Illustration 26

g00708212

26. Fasten Tooling (D) and a suitable lifting device to main housing (18), as shown.
27. Use a hammer and a punch to separate main housing (18) and the final drive sprocket from the motor housing (28). The combined weight of main housing (18) and the final drive sprocket is approximately 82 kg (180 lb).

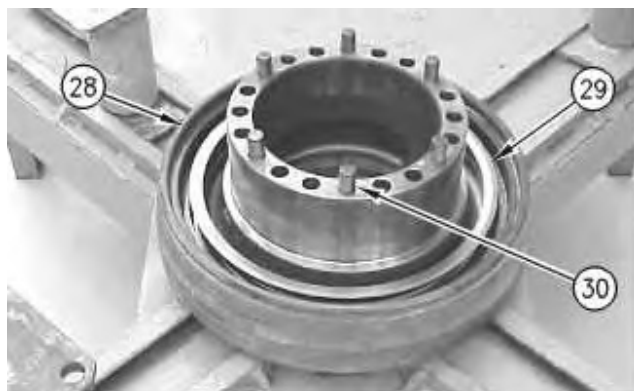

Illustration 27

g00708214

28. Remove Duo-Cone seal (29) from motor housing (28).

29. Remove alignment pins (30).

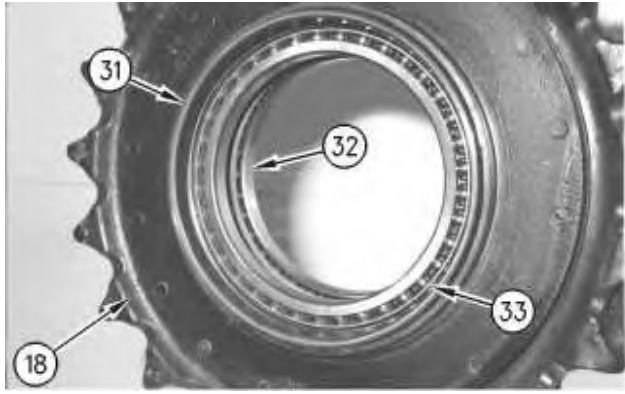

Illustration 28

g00708215

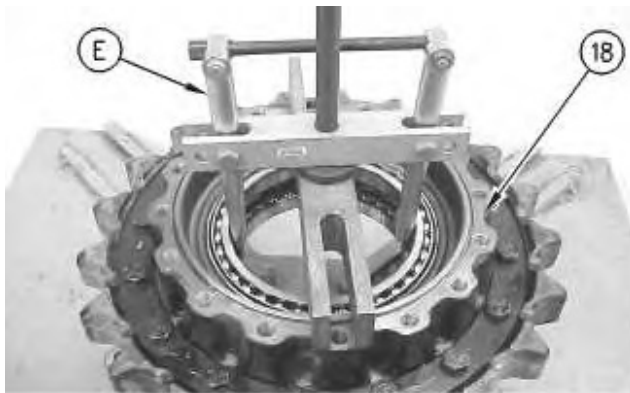

Illustration 29

g00708216

30. Remove Duo-Cone seal (31) from main housing (18).

31. Use Tooling (E) to remove bearings (32) and (33) from the main housing.

32. If necessary, remove the final drive sprocket from the main housing.

33. Refer to Disassembly and Assembly, "Final Drive Sprocket - Remove and Install".

Assembly Procedure

Table 4

| Required Tools | | | |
|----------------|-------------|---------------------------|-----|
| Tool | Part Number | Part Description | Qty |
| A | 1P-2420 | Transmission Repair Stand | 1 |
| B | 439-3938 | Link Bracket | 2 |
| D | 439-3939 | Link Bracket As | 2 |
| G | 126-3994 | Duo-Cone Seal Installer | 1 |
| | | | |

| | | | |
|---|---------|---------------------|--|
| H | 5P-3931 | Anti-Seize Compound | |
| F | 1U-8846 | Gasket Sealant | |

Note: Apply a light film of hydraulic oil to all components before assembly.

1. Install the final drive sprocket if the sprocket was removed from the main housing.
2. Remove the final drive sprocket.

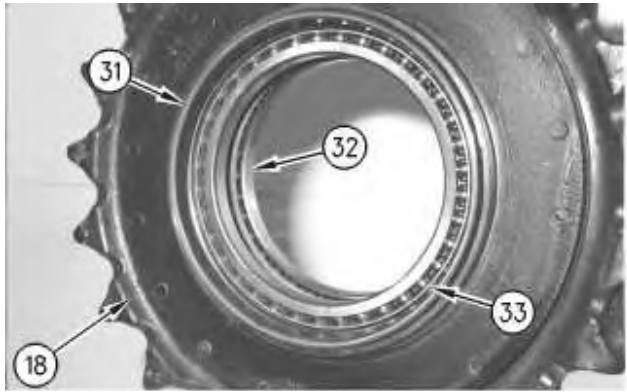

Illustration 30

g00708215

3. Apply Tooling (H) to the outer diameter of the bearings.
4. Install bearings (32) and (33) in main housing (18) with a suitable press.
5. Make sure that bearing (32) and bearing (33) contact the counterbore in the main housing.
6. Use the following procedure to preload the bearings and determine the correct thickness of shims.

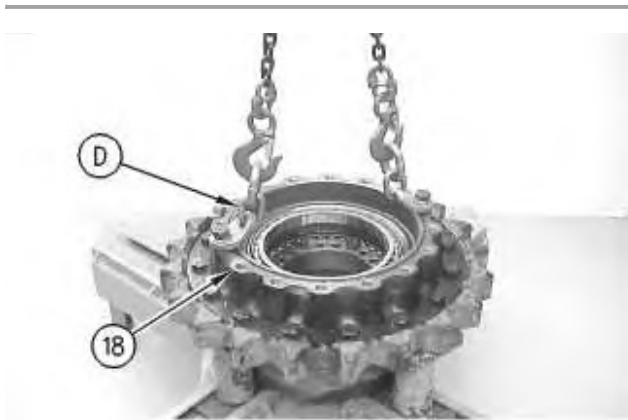

Illustration 31

g00713058

- a. Fasten Tooling (D) and a suitable lifting device to main housing (18). Install the main housing on the motor housing.
 - b. Put the main housing and the motor housing in a suitable press.
-

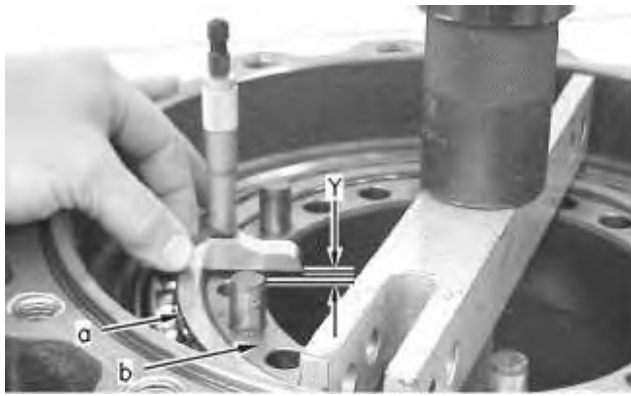

Illustration 32

g00709278

- (a) Bearing surface
- (b) Housing surface

- c. Use a suitable press and a spacer to apply a load of 4000 kg (8819 lb) on the bearings. Rotate the housing to seat the bearings.
- d. Reduce the load on the bearings to 1000 ± 100 kg (2205 ± 221 lb).
- e. Use a depth micrometer to measure the step length between the bearing surface and the housing surface. Take measurements at several different locations around the housing. Compute the average of the measured dimensions and record the number. Call this Dimension (Y).

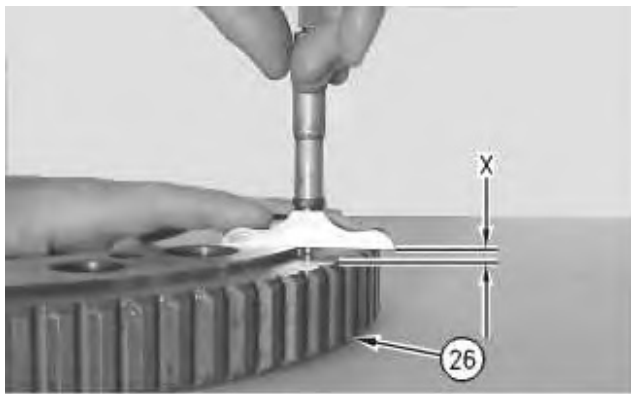

Illustration 33

g00709276

- f. Use a depth micrometer to measure the step length of the coupling gear (26). Take measurements at several different locations around the gear. Compute the average of the measured dimensions and record the number. Call this Dimension (X).
 - g. The thickness of the shims is equal to $(X - Y) \pm 0.05$ mm (0.002 inch).
- Note:** Use no more than two shims. If two shims are required, install the thinner shim next to the gear.
- h. Remove the main housing from the motor housing.



Illustration 34

g01021370

7. Use Tooling (G) to install Duo-Cone seal (31) in main housing (18). Refer to Disassembly and Assembly, "Duo-Cone Conventional Seals - Install".

Note: The rubber seals and all surfaces that contact the seals must be clean and dry. After installation of the seals, put clean SAE 30 oil on the contact surfaces of the metal seals.



Illustration 35

g01021371

8. Use Tooling (G) to install Duo-Cone seal (29) in motor housing (28).

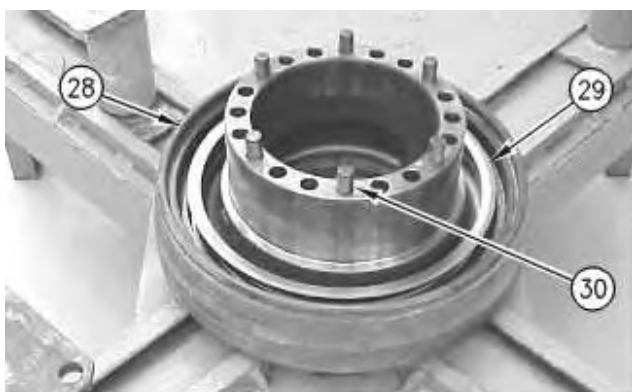

Illustration 36

g00708214

9. Apply Tooling (H) to the surfaces that contact pins (30).

10. Install alignment pins (30).

Note: Do not damage the Duo-Cone seals in the main housing or in the motor housing during the assembly of the two components. After installation of the main housing on the motor housing, there will be a small gap between the components. The gap is caused by the Duo-Cone seals. This gap will be eliminated during installation of gear (26).

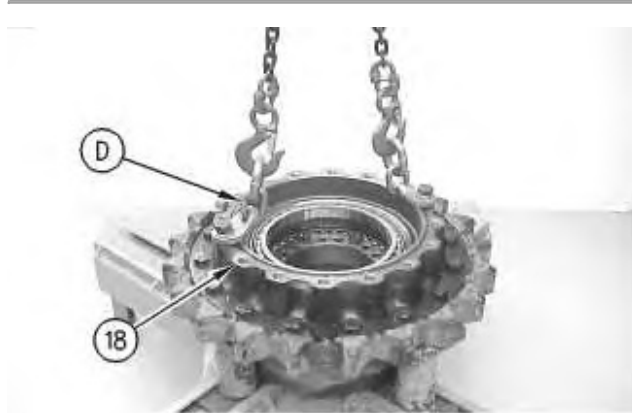

Illustration 37

g00713058

11. Fasten Tooling (D) and a suitable lifting device to main housing (18). Install the main housing on the motor housing.



Illustration 38

g00708211

12. Install shims (27) that were determined in Step 6.g in the main housing.

Note: If two shims are required, install the thinner shim next to the gear.



Illustration 39

g00708187

13. Install gear (26).
14. Install bolts (25) in gear (26). Install the bolts in an even pattern until the gear is seated against the bearing. Tighten bolts (25) in a crisscross pattern.

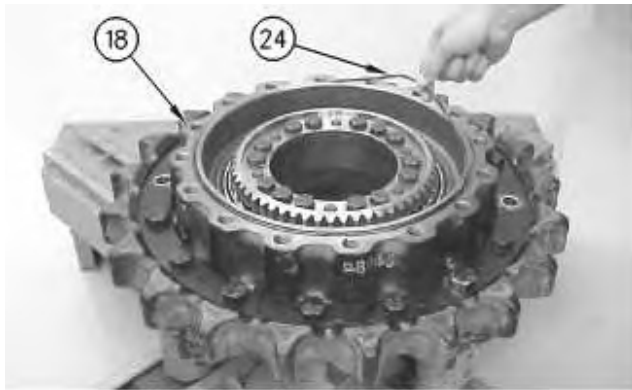

Illustration 40

g00708186

15. Install O-ring seal (24) to main housing (18).



Illustration 41

g00708175

16. Assemble carrier assembly (15), as follows.

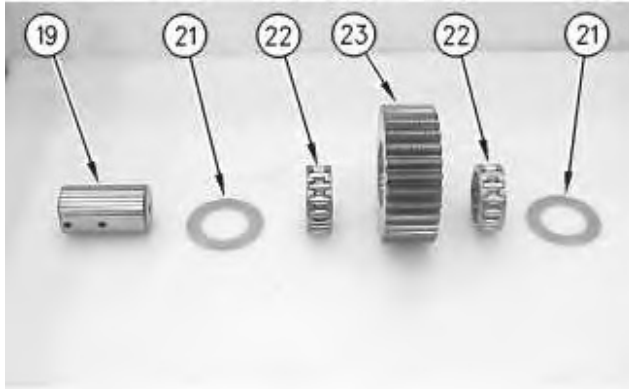

Illustration 42

g00708220

- a. Install bearings (22) in planetary gear (23).
- b. Install thrust washers (21) and planetary gear (23) in the carrier assembly.
- c. Use a deburring tool to remove the metal burr from the openings in the carrier. Install planetary shaft (19) in the carrier assembly.
- d. Drive spring pin (20) into planetary shaft (19) with a hammer and a punch.

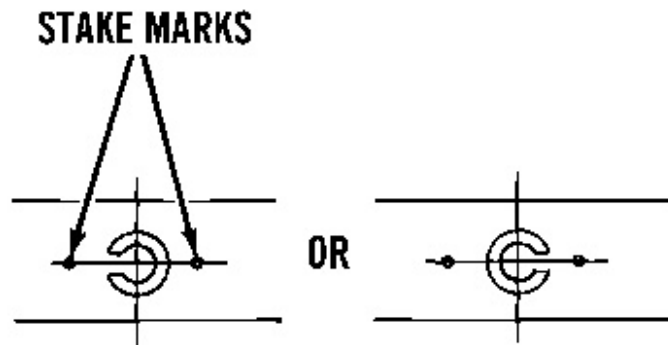

Illustration 43

g00513451

- e. Orient the split in spring pin (20) vertically to the carrier. Align the split in the spring pin to the top or to the bottom. Make a stake mark on each side of the spring pin hole in the carrier. Each stake mark should be approximately 1.50 mm (0.059 inch) from the outside diameter of the spring pin hole.
17. Repeat Steps 16.a through 16.e to install the remaining planetary gears in the carrier assembly.

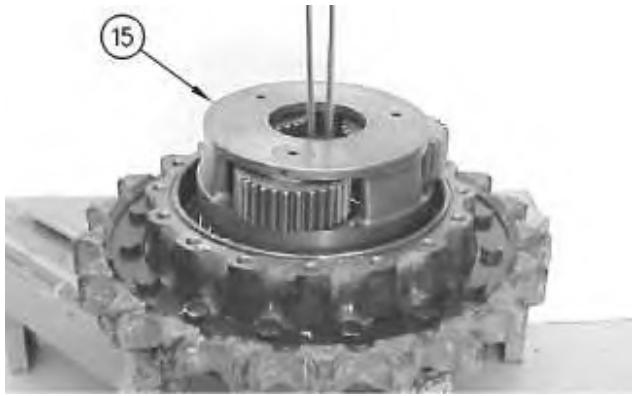

Illustration 44

g00708172

18. Install a lifting sling through the middle of carrier assembly (15). Fasten a 12.7 mm (0.50 inch) shackle to the suitable lifting device.
19. Install carrier assembly (15) on the final drive. The weight of carrier assembly (15) is approximately 39 kg (85 lb).
20. Remove the shackle and the suitable lifting device.



Illustration 45

g00713148

21. Apply Tooling (F) to the mating surface of ring gear (17b).
22. Install ring gear (17a) on ring gear (17b).

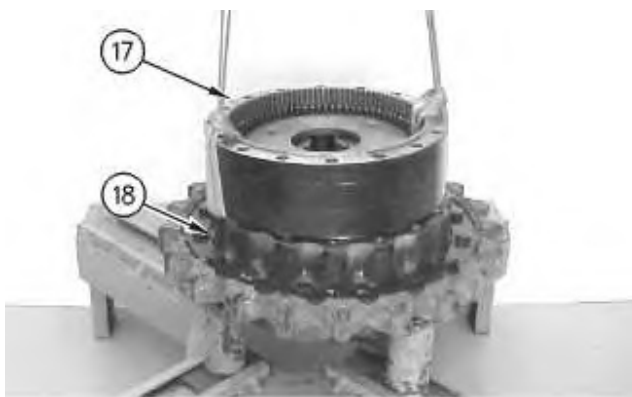

23. Fasten a suitable lifting device to ring gears (17), as shown. Install the ring gears to main housing (18). The weight of ring gears (17) is approximately 45 kg (100 lb).

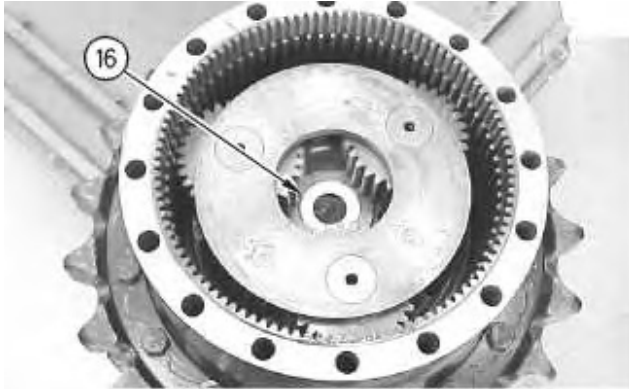

Illustration 47

24. Install spacer (16) in the carrier assembly.

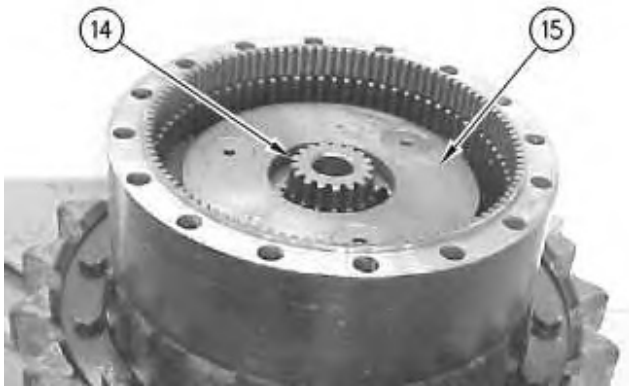

Illustration 48

25. Install sun gear (14) in carrier assembly (15).



Illustration 49

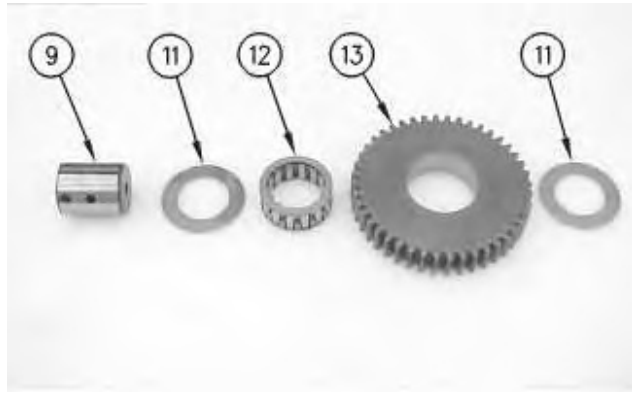

Illustration 50

g00708218

26. Assemble carrier assembly (7), as follows.
- Install bearing (12) in planetary gear (13).
 - Install thrust washers (11) and planetary gear (13) in the carrier assembly.
 - Install planetary shaft (9) in the carrier assembly.
 - Drive spring pin (10) into planetary shaft (9) with a hammer and a punch.
-

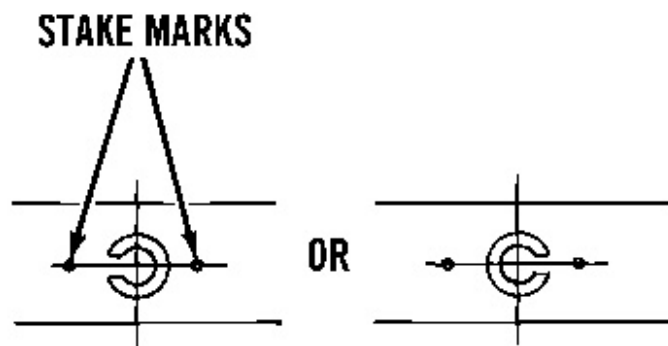

Illustration 51

g00513451

- Orient the split in spring pin (10) vertically to the carrier. Align the split in the spring pin to the top or to the bottom. Make a stake mark on each side of the spring pin hole in the carrier. Each stake mark should be approximately 1.50 mm (0.059 inch) from the outside diameter of the spring pin hole.
27. Repeat Steps 26.a through 26.e to install the remaining planetary gears in the carrier assembly.
-

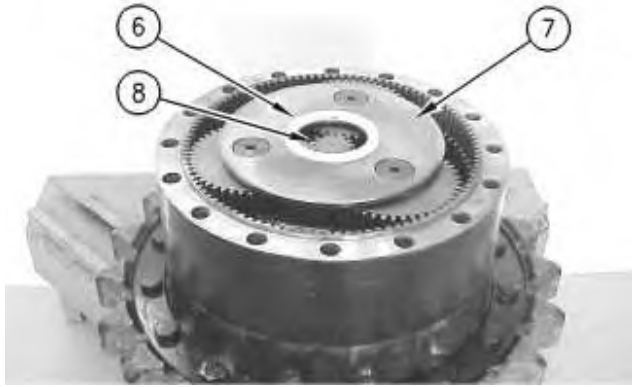

Illustration 52

g00708092

28. Install carrier assembly (7) in the ring gear. The weight of carrier assembly (7) is approximately 14 kg (30 lb).
29. Install sun gear (8) in carrier assembly (7).
30. Install spacer (6) in carrier assembly (7).

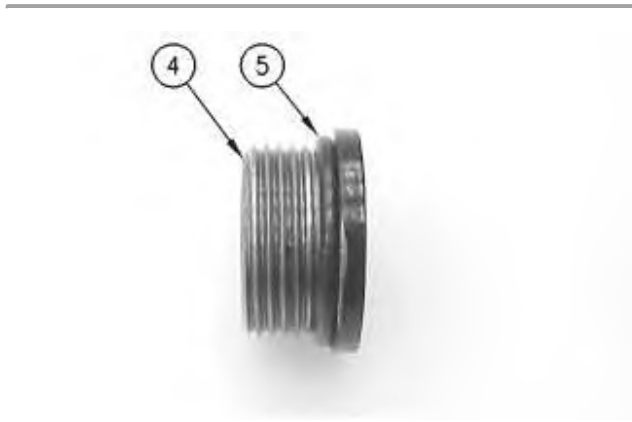

Illustration 53

g00708235

31. Install new O-ring seals (5) on plugs (4) that were in the cover.

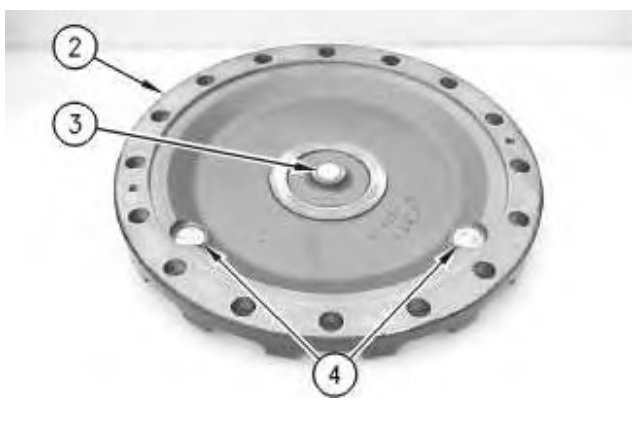

Illustration 54

g00708091

32. Install plugs (4) in cover (2). Tighten plugs (4) to a torque of 80 ± 10 N·m (59 ± 7 lb ft).

33. Install thrust plate (3) in cover (2).
34. Apply Tooling (F) to the mating surface of the ring gear.

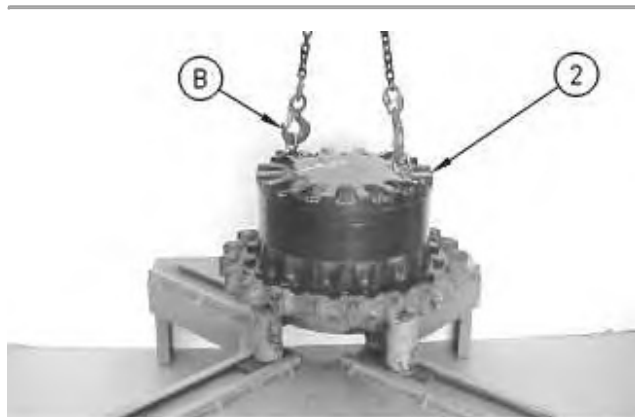

Illustration 55

g00708090

35. Fasten Tooling (B) and a suitable lifting device to cover (2), as shown. The weight of cover (2) is approximately 32 kg (70 lb). Install cover (2).
36. Remove Tooling (B). Install the setscrews in cover (2).



Illustration 56

g00708089

37. Install bolts (1) and the washers that hold the cover in position. Tighten bolts (1) in a crisscross pattern.
38. Remove the final drive from Tooling (A). The combined weight of the final drive and final drive sprocket is approximately 310 kg (683 lb).

End By:

- a. Install the final drive.

Previous Screen

Product: EXCAVATOR

Model: 323E SA EXCAVATOR YRP

Configuration: 323E L, 323E LN & 323E SA Excavators YRP00001-UP (MACHINE) POWERED BY C6.6 Engine

**Disassembly and Assembly
320E and 323E Excavators Machine Systems**

Media Number -KENR9842-01

Publication Date -01/03/2013

Date Updated -28/03/2013

i04415216

Swivel

SMCS - 5060

Specifications

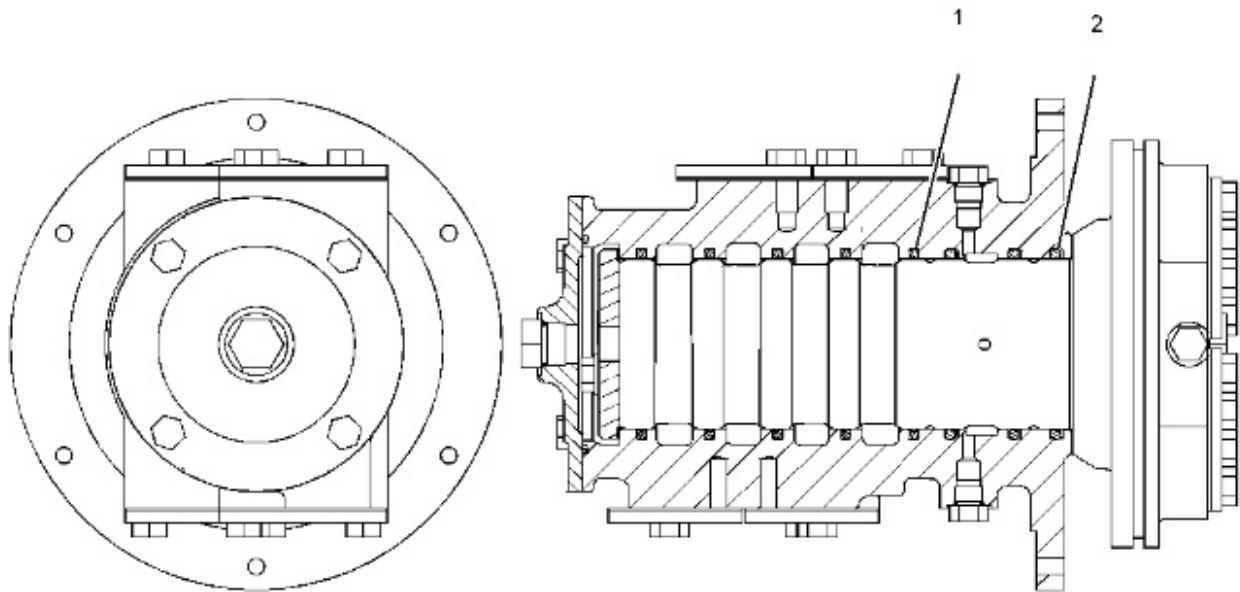

Illustration 1

g02540007

Typical example

Table 1

Specification for 234-4440 Swivel Gp, 225-4547 Swivel Gp, 162-4695 Swivel Gp, and 162-4696 Swivel Gp

| Item | Qty | Part | Specification Description |
|------|-----|------|---------------------------|
|------|-----|------|---------------------------|

| | | | |
|---|---|-----------------------------|--|
| 1 | 5 | 159-7782 Seal | Lubricate the seals and the shaft lightly with the lubricant or with the clean grease that is being sealed. |
| 2 | 3 | 095-1625 O-Ring Seal | Lubricate the O-ring seals and the shaft lightly with the lubricant or with the clean grease that is being sealed. |
| After assembly, the swivel group must be rotated to the position that is shown. | | | |

Removal Procedure

Table 2

| Required Tools | | | |
|-----------------------|--------------------|---------------------------|------------|
| Tool | Part Number | Part Description | Qty |
| A | FT-2674 | Vacuum Cap | 1 |
| B | 5P-3050 | Floor Jack Gp | 1 |
| C | 138-7575 | Link Bracket | 2 |
| D | - | Loctite 242 | - |
| E | 1P-2420 | Transmission Repair Stand | 1 |

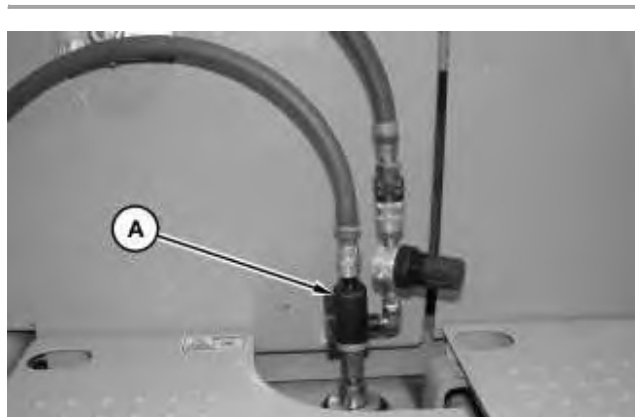

Illustration 2

g02726974

1. Remove the cap from the hydraulic tank. Install Tooling (A) onto the hydraulic tank. Attach an air supply hose to Tooling (A). Apply 276 to 414 kPa (40 to 60 psi) of air. This procedure will pull vacuum on the hydraulic system.

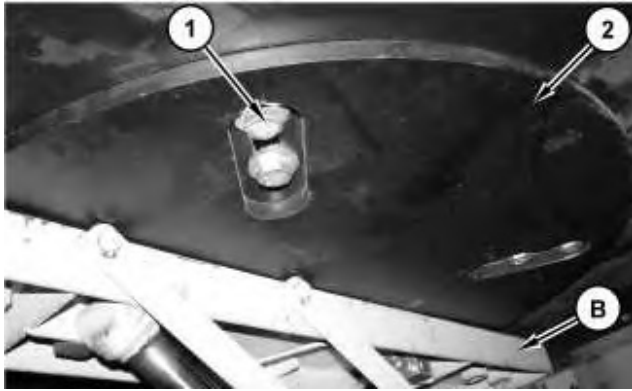

Illustration 3

g02615566

2. Attach Tooling (B) under guard (2). The weight of guard (2) is approximately 75 kg (165 lb). Loosen bolts (1), slide bolts inward to release the locks. Remove guard (2).



Illustration 4

g02626110

3. Remove bracket (3). Remove hose assemblies (4).

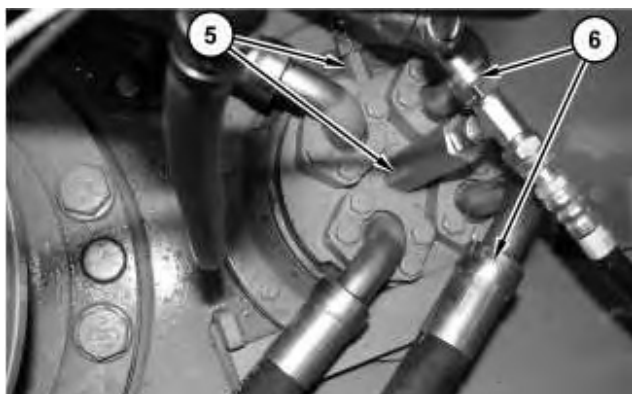

Illustration 5

g02626112

4. Remove hose assemblies (6). Remove fittings (5).

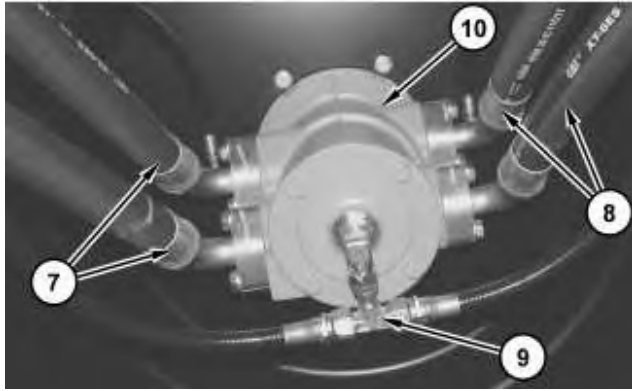

Illustration 6

g02615556

5. Remove hose assemblies (7), hose assemblies (8), and fittings (9) from swivel (10).

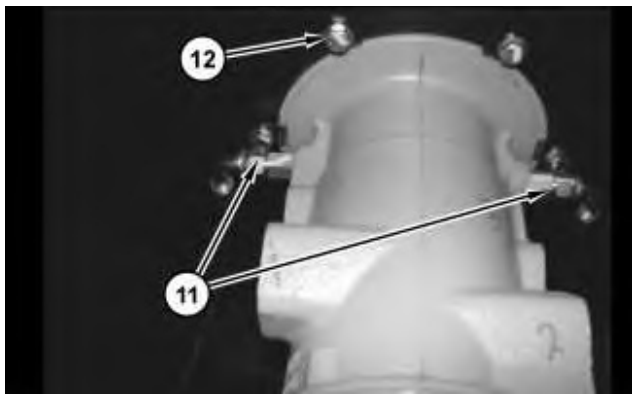

Illustration 7

g02615564

6. Remove hose assemblies and fittings (11). Remove bolts (12).

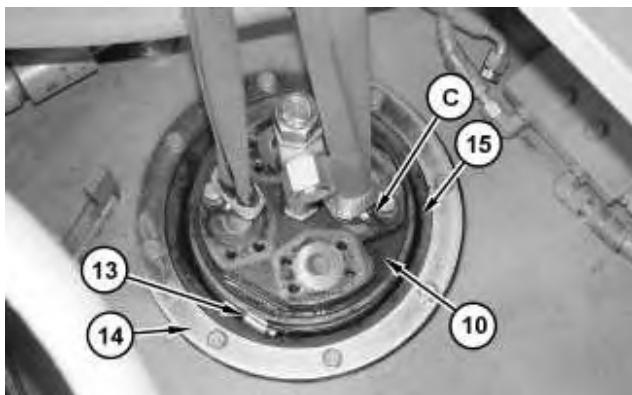

Illustration 8

g02727286

7. Attach Tooling (C) and a suitable lifting device to swivel (10). The weight of the swivel (10) is approximately 50 kg (110 lb). Remove clamp (13), retainer (14) and boot (15).

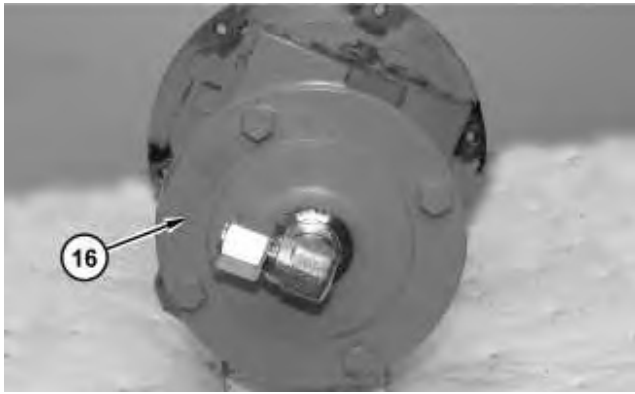

Illustration 9

g02615558

8. Remove cover (16).

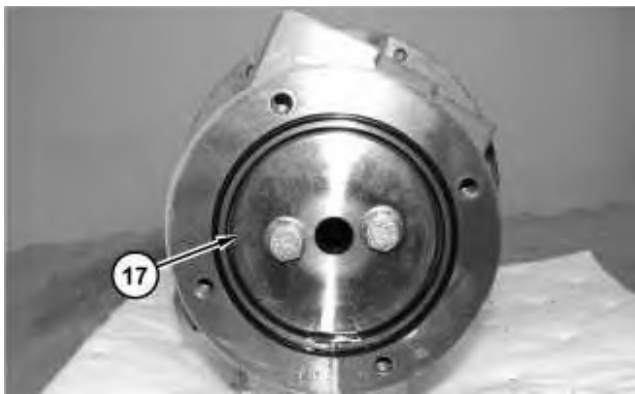

Illustration 10

g02615560

9. Remove retainer (17).

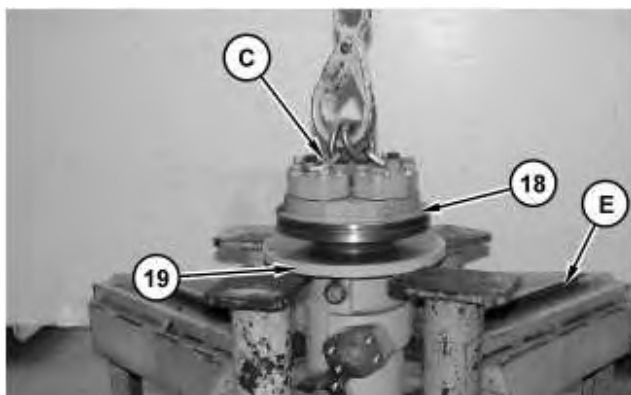

Illustration 11

g02615557



Suggest:

If the above button click is invalid.

Please download this document

first, and then click the above link

to download the complete manual.

Thank you so much for reading



Illustration 12

g02615562

10. Attach Tooling (C) and a suitable lifting device to the swivel and locate in Tooling (E). The weight of swivel (10) is approximately 45 kg (100 lb). Remove rotor (18) from swivel housing (19).



Illustration 13

g02615563

11. Remove seals (20).

Installation Procedure

1. Install swivel (10) in the reverse order of removal.

Note: Lubricate seals (20) and rotor (18) with clean hydraulic oil for assembly.

- a. Apply sealant between the mating surface of swivel (10) and the undercarriage before installing swivel (10). Apply Tooling (D) to bolts (12).

<https://www.ebooklibonline.com>

Hello dear friend!

Thank you very much for reading.

Enter the link into your browser.

The full manual is available for immediate download.

<https://www.ebooklibonline.com>