



Service Repair Manual

Models

315C EXCAVATOR

Previous Screen

Product: EXCAVATOR
 Model: 315C EXCAVATOR CFL
 Configuration: ISJ HEX COMMONALITY CHART CFL00001-UP (MACHINE)

**Disassembly and Assembly
 315C Excavator Machine Systems**

Media Number -REN5525-05

Publication Date -01/11/2008

Date Updated -10/11/2008

i01960779

Final Drive - Disassemble

SMCS - 4050-015

Disassembly Procedure

Table 1

Required Tools			
Tool	Part Number	Part Description	Qty
A	1P-2420	Repair Stand	1
B	1U-7600	Slide Hammer	1
C	138-7575	Link Brackets	3
D	154-6181	Forcing Screw	2

Start By:

- A. Remove the final drive. Refer to Disassembly and Assembly, "Final Drive- Remove".

NOTICE

Care must be taken to ensure that fluids are contained during performance of inspection, maintenance, testing, adjusting and repair of the product. Be prepared to collect the fluid with suitable containers before opening any compartment or disassembling any component containing fluids.

Refer to Special Publication, NENG2500, "Caterpillar Tools and Shop Products Guide" for tools and supplies suitable to collect and contain fluids on Caterpillar products.

Dispose of all fluids according to local regulations and mandates.

NOTICE

Failure to properly assemble parts or failure to follow established procedures can lead to damage of the parts and assembly.

To avoid damage to parts, always identify and mark the parts so that they can be installed in the same location. Ensure that gear surfaces align. Never force parts during assembly.



Illustration 1

g00777501

1. Install the final drive assembly on Tooling (A) .

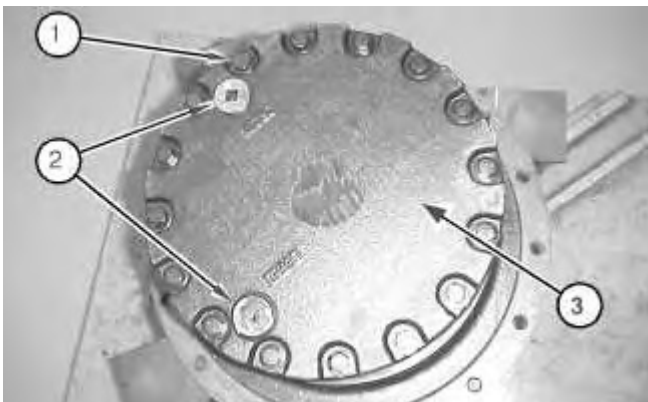

Illustration 2

g01018685

<https://www.ebooklibonline.com>

Hello dear friend!

Thank you very much for reading.

Enter the link into your browser.

The full manual is available for immediate download.

<https://www.ebooklibonline.com>

2. Remove bolts (1). Remove plugs (2) and the O-ring seals from cover (3). Remove cover (3) .

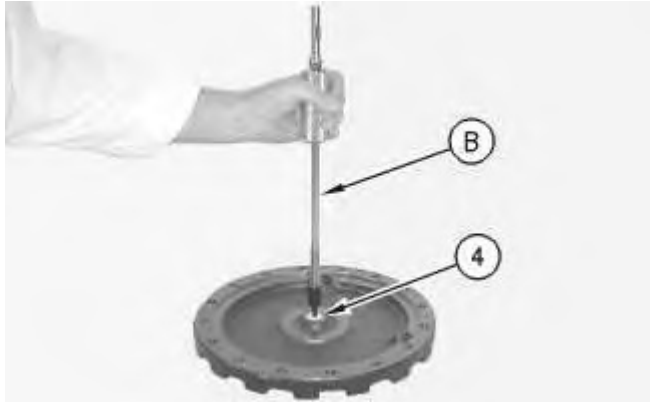

Illustration 3

g00777515

3. Use Tooling (B) in order to remove plate (4) .



Illustration 4

g00777542

4. Remove carrier assembly (5) from the main housing. The weight of the carrier assembly is approximately 16 kg (35 lb).
-



Illustration 5

g00777548

5. Remove spacer (6) .



Illustration 6

g00777570

6. Use a suitable punch and a hammer to install spring pin (7) into planetary shaft (8) .

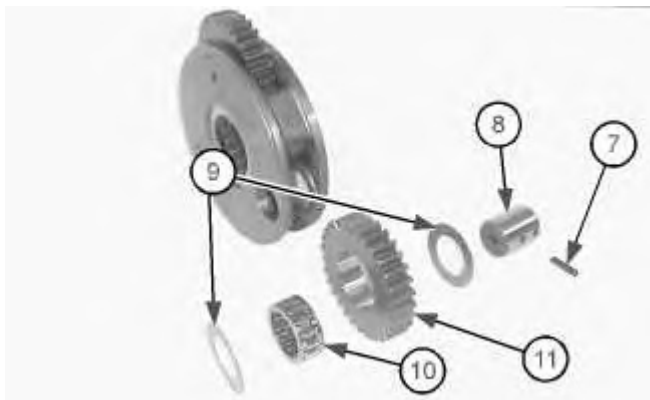

Illustration 7

g01021689

7. Remove planetary shaft (8). Remove spring pin (7). Remove thrust washers (9). Remove planetary gear (11) and bearing (10) .
8. Repeat Steps 6 and 7 in order to remove the other two planetary gears from the carrier.



Illustration 8

g00777624

9. Remove gear (12) .

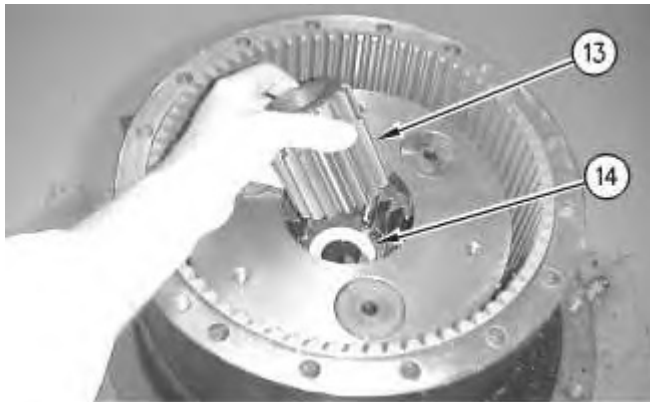

Illustration 9

g00777626

10. Remove gear (13). Remove spacer (14) .
-

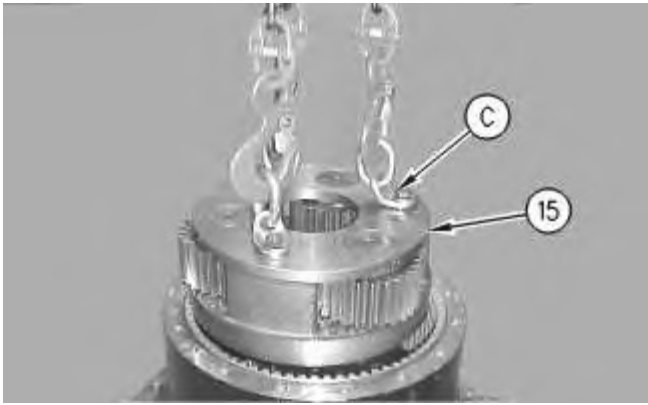

Illustration 10

g00777631

11. Use Tooling (C) and a suitable lifting device in order to remove carrier assembly (15). The weight of carrier assembly (15) is approximately 30 kg (65 lb).

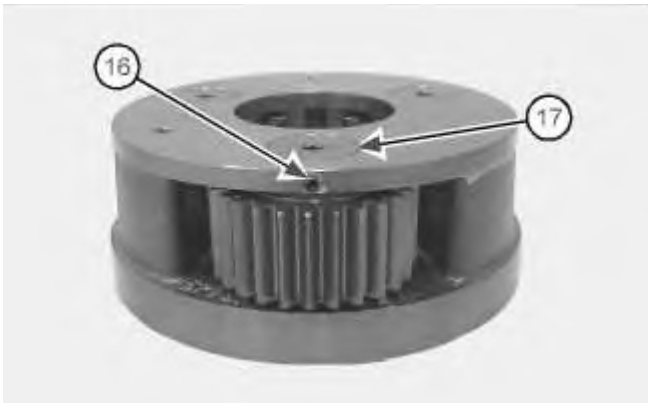

Illustration 11

g01021690

12. Use a suitable punch and a hammer to install spring pin (16) into planetary shaft (17) .

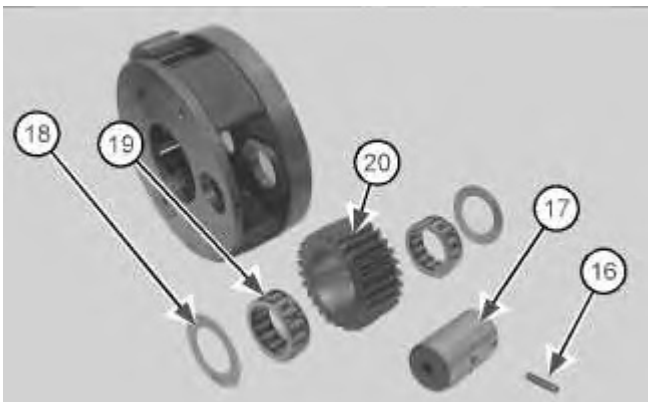

Illustration 12

g01021692

13. Remove spring pin (16) from planetary shaft (17). Remove thrust washers (18), bearings (19) and gear (20) from the carrier assembly.

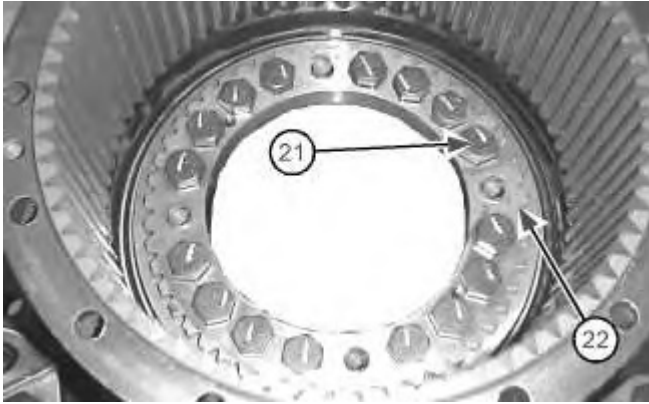

Illustration 13

g01018688

14. Remove bolts (21) .

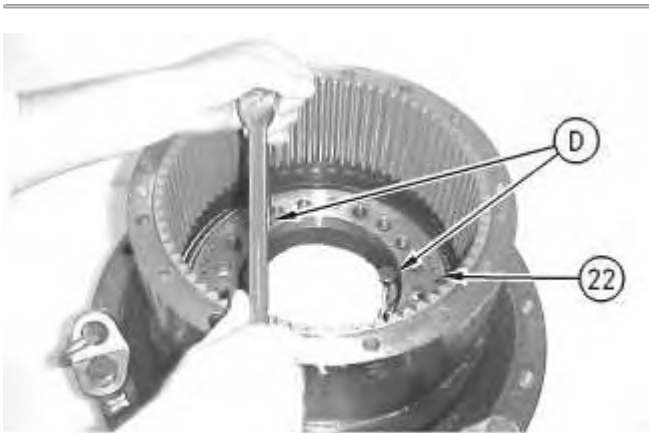

Illustration 14

g00778413

15. Use Tooling (D) in order to push gear (22) from the upper housing.
-



Illustration 15

g00778461

16. Remove gear (22). Four dowel pins (23) will stay with the gear.

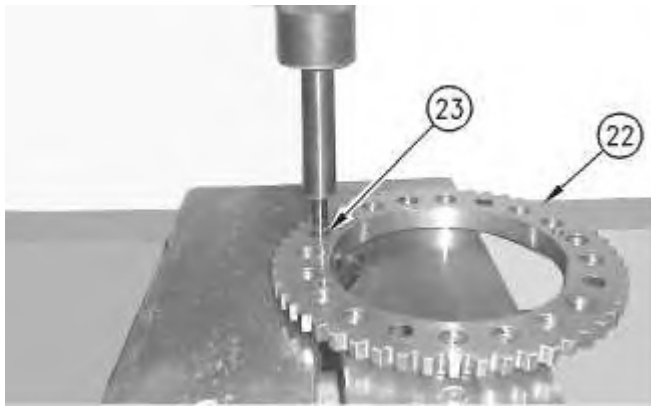

Illustration 16

g00778471

17. Use a suitable press in order to remove dowel pins (23) .



Illustration 17

g01018689

18. Remove shim (24) and washer (25) .



Illustration 18

g01018690

19. Separate housing (26) from housing (27) .



Illustration 19

g01018692

20. Remove Duo-cone seal gp (28) from housing (27) .

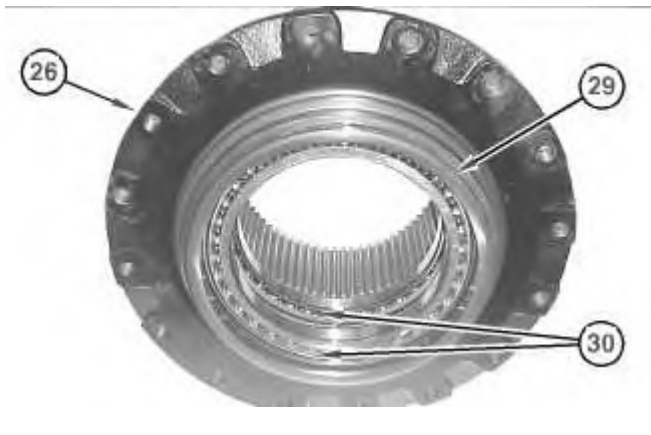

21. Remove Duo-cone seal gp (29) and bearings (30) from housing (26) .

[Copyright 1993 - 2020 Caterpillar Inc.](#)

Mon Nov 2 08:44:27 UTC+0800 2020

[All Rights Reserved.](#)

[Private Network For SIS Licensees.](#)

[Previous Screen](#)

◀ Product: EXCAVATOR
 Model: 315C EXCAVATOR CFL
 Configuration: ISJ HEX COMMONALITY CHART CFL00001-UP (MACHINE)

Disassembly and Assembly 315C Excavator Machine Systems

Media Number -REN5525-05

Publication Date -01/11/2008

Date Updated -10/11/2008

i01961218

Final Drive - Assemble

SMCS - 4050-016

Assembly Procedure

Table 1

Required Tools			
Tool	Part Number	Part Description	Qty
A	1P-2420	Repair Stand	1
C	138-7575	Link Brackets	3
D	126-3994	Seal Installer	1
E	1U-9895	Crossblock	1
	5F-7369	Leg	2
	5P-4808	Cap	2
	3H-0465	Plate	4
	1B-4207	Nut	2
F	6V-2012	Depth Micrometer	1
G	169-0503	Installation Kit	1

Note: Replace all O-ring seals and gaskets. Apply a light film of "10W" oil to all components before assembly.

Note: Cleanliness is an important factor. Before assembly, all parts should be thoroughly cleaned in cleaning fluid. Allow the parts to air dry. Wiping cloths or rags should not be used to dry parts. Lint may be deposited on the parts which may cause later trouble. Inspect all parts. If any parts are worn or damaged, use new parts for replacement.



Illustration 1

g01021697

1. Place housing (27) on Tooling (A) .
2. Use Tooling (G) in order to clean the Duo-cone seal gp prior to installation. Use Tooling (D) in order to install Duo-cone seal gp (28) into housing (27) .



Illustration 2

g01018693

3. Install bearings (30) into housing (26). Use Tooling (D) in order to install Duo-cone seal gp (29) into housing (26).
-



Illustration 3

g01018690

4. Install Tooling (C) to housing (26). Use Tooling (C) and a suitable lifting device in order to install housing (26) onto housing (27) .

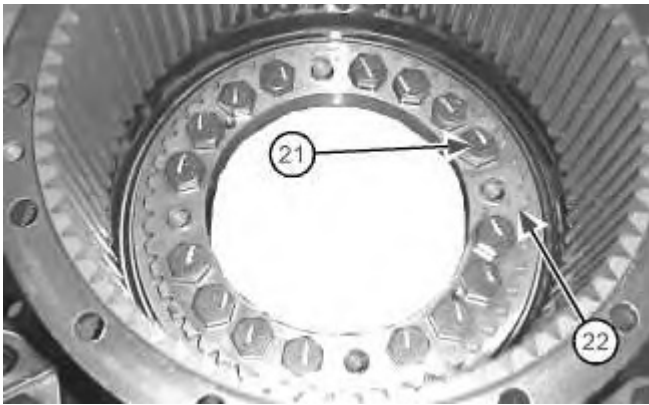

Illustration 4

g01018688

5. Install gear (22). Install bolts (21) in order to hold the two housings together. This is necessary in order to transport the housings to the press.

Note: The following steps are necessary in order to determine the proper shim or shims needed to set the rolling torque.

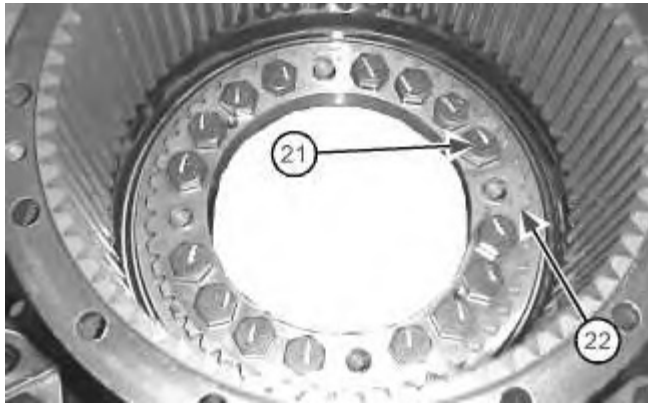

Illustration 5

g01018688

- a. Set the main housing assembly in a suitable press. Remove bolts (21). Remove gear (22) .

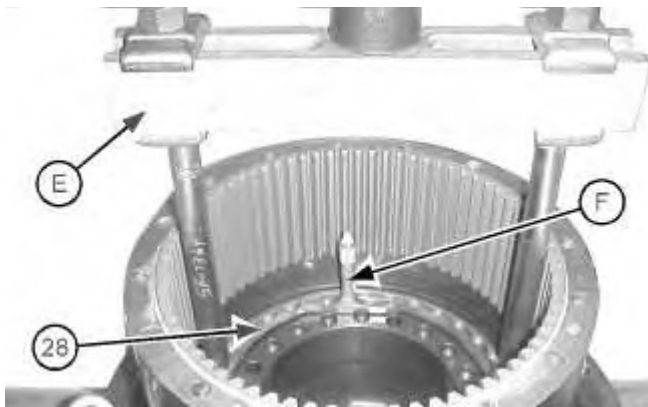

Illustration 6

g01021714

- b. Install Tooling (E). Use a suitable press in order to apply the load of 4000 kg (8818 lb). Rotate the housing in order to seat bearings (30). Reduce the load to 1000 ± 100 kg (2204 ± 220 lb).

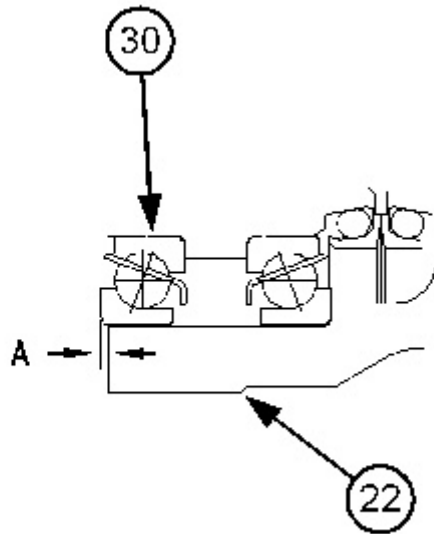

Illustration 7

g01018888

- c. Maintain the load pressure of 1000 ± 100 kg (2204 ± 220 lb). Use Tool (F) in order to obtain Measurement (A). Record the measurement.
-

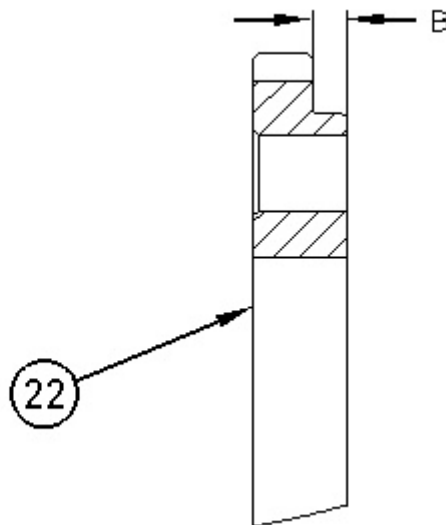

Illustration 8

g00781842

- d. Use Tooling (F) in order to obtain Measurement (B) on gear (22). Record the measurement.
-

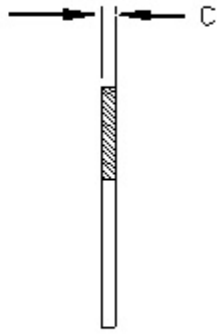

Illustration 9

g00781847



Illustration 10

g01018689

- e. Measure the thickness of washer (25). Record the measurement.
 - f. Install washer (25). Install the required shims. The shim thickness is determined by subtracting Dimension (A) from Dimension (B) and subtracting Dimension (C). This thickness has a tolerance of ± 0.050 mm (± 0.0020 inch). If two shims are required, install the thinner shim next to gear (22).
-



Illustration 11

g00782429

6. Install gear (22) and pins (23). Install bolts (21). Tighten bolts (21) to a torque of 270 ± 40 N·m (199 ± 30 lb ft).

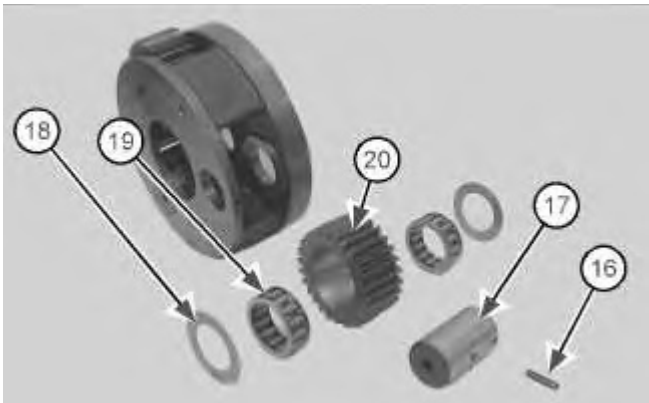

Illustration 12

g01021692

7. Install bearings (19) and gear (20). Install thrust washers (18). Install planetary shaft (17) and spring pin (16) .

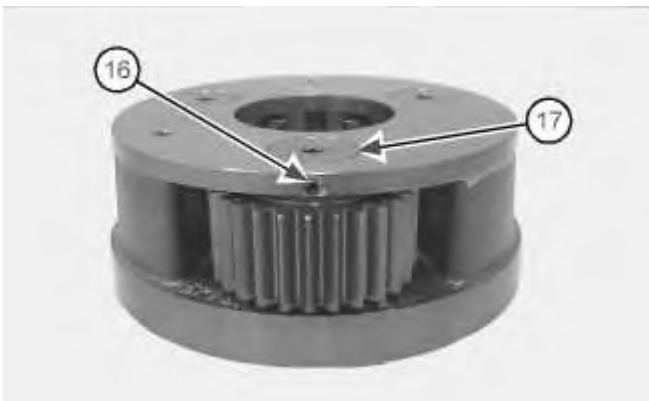

Illustration 13

g01021690

- Use a suitable punch and a hammer in order to drive spring pin (16) into planetary shaft (17).

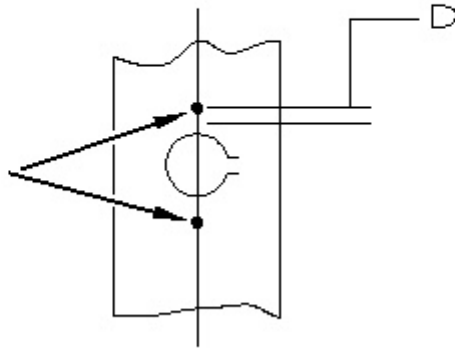

Illustration 14

g00782239

Stake marks on each side of spring pin (16)

(D) Measurement of 1.5 mm (0.06 inch) from outside diameter

- Use a suitable punch in order topeen planetary shaft (17) on each side of spring pin (16). Each stake mark should be approximately 1.5 mm (0.06 inch) from the outside diameter of the spring pin.
- Repeat Steps 7 through 9 in order to install the other two planetary gears into the carrier.

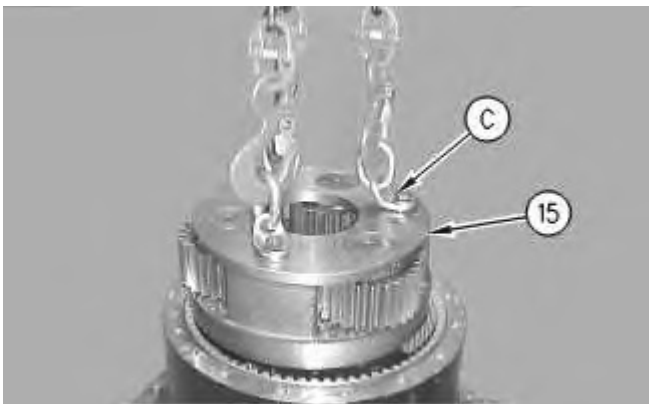

Illustration 15

g00777631

11. Use Tooling (C) and a suitable lifting device in order to install carrier assembly (15). The weight of carrier assembly (15) is approximately 30 kg (65 lb).

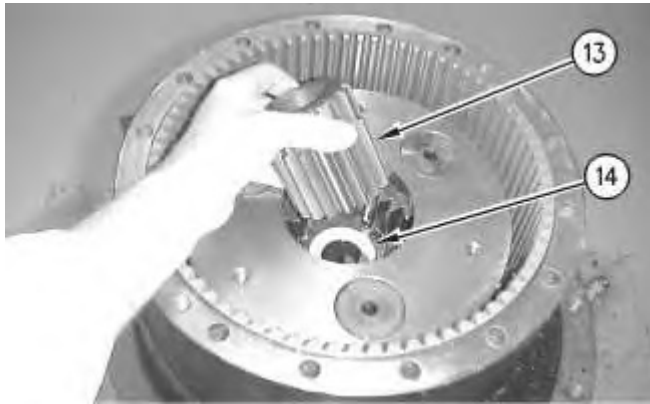

Illustration 16

g00777626

12. Install spacer (14). Install gear (13).



Illustration 17

g00777624

13. Install gear (12) .
-

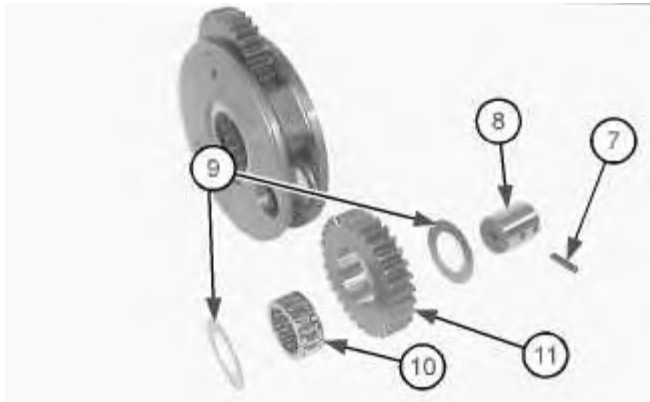

Illustration 18

g01021689

14. Install planetary gear (11) and bearing (10). Install thrust washers (9). Install planetary shaft (8). Install spring pin (7).

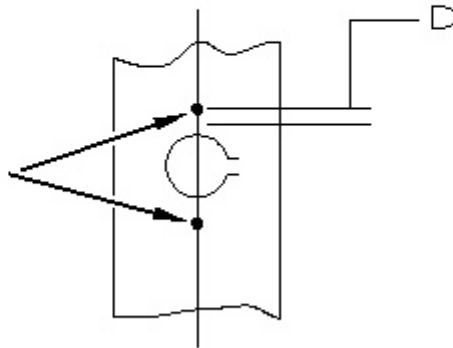

Illustration 19

g00782239

Stake marks on each side of spring pin (7)

(D) Measurement of 1.5 mm (0.06 inch) from outside diameter

15. Use a suitable punch in order topeen shaft (8) on each side of spring pin (7). Each stake mark should be approximately 1.5 mm (0.06 inch) from the outside diameter of the spring pin.
16. Repeat Steps 14 and 17 in order to install the other two planetary gears into the carrier.



Illustration 20

g00777548

17. Install spacer (6) .



Illustration 21

g00777542

18. Install carrier assembly (5) into the main housing. The weight of carrier assembly (5) is approximately 16 kg (35 lb).



Illustration 22

g00782448

19. Install plate (4) .

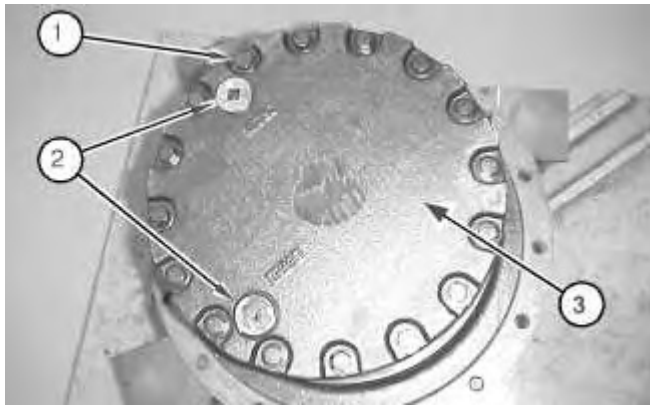

Illustration 23

g01018685

20. Install cover (3). Install bolts (1). Tighten bolts (1) to a torque of 105 ± 20 N·m (77 ± 15 lb ft). Install plugs (2) and the O-ring seals. Tighten plugs (2) to a torque of 80 ± 10 N·m (59 ± 7 lb ft).

End By: Install the final drive. Refer to Disassembly and Assembly, "Final Drive - Install".

[Previous Screen](#)

◀ Product: EXCAVATOR
 Model: 315C EXCAVATOR CFL
 Configuration: ISJ HEX COMMONALITY CHART CFL00001-UP (MACHINE)

Disassembly and Assembly 315C Excavator Machine Systems

Media Number -REN5525-05

Publication Date -01/11/2008

Date Updated -10/11/2008

i01961382

Final Drive - Install

SMCS - 4050-012

Installation Procedure

Table 1

Required Tools			
Tool	Part Number	Part Description	Qty
A	138-7574	Link Bracket	2
C	9S-3263	Thread Lock Compound	1

1. Make sure that the mating surfaces of the final drive and the undercarriage frame are thoroughly clean and free of dirt and debris prior to assembly.
2. Check the condition of the O-ring seals that are used in the ends of the tube assemblies. Check the condition of the O-ring seals that are used in the ends of the hose assemblies. If the O-ring seals are worn or damaged, use new parts for replacement.

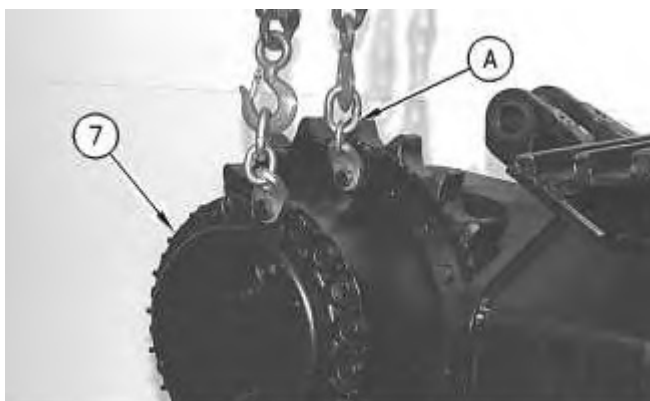

3. Fasten Tooling (A) and a suitable lifting device to final drive (7). Carefully, put the final drive in position on the undercarriage frame.

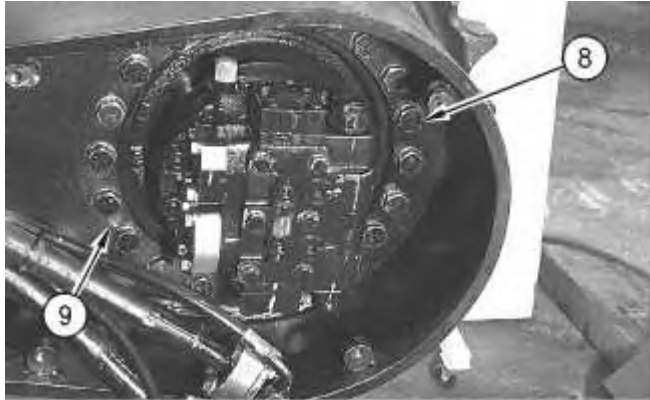

Illustration 2

g00486988

4. Apply Tooling (C) on the threads of bolts (8). Install bolts (8) that hold the final drive to the undercarriage frame. Tighten bolts (8) evenly.
5. Install plugs (9) in the forcing bolt holes.

NOTICE

Care must be taken to ensure that fluids are contained during performance of inspection, maintenance, testing, adjusting and repair of the product. Be prepared to collect the fluid with suitable containers before opening any compartment or disassembling any component containing fluids.

Refer to Special Publication, NENG2500, "Caterpillar Tools and Shop Products Guide" for tools and supplies suitable to collect and contain fluids on Caterpillar products.

Dispose of all fluids according to local regulations and mandates.



Suggest:

If the above button click is invalid.

Please download this document

first, and then click the above link

to download the complete manual.

Thank you so much for reading

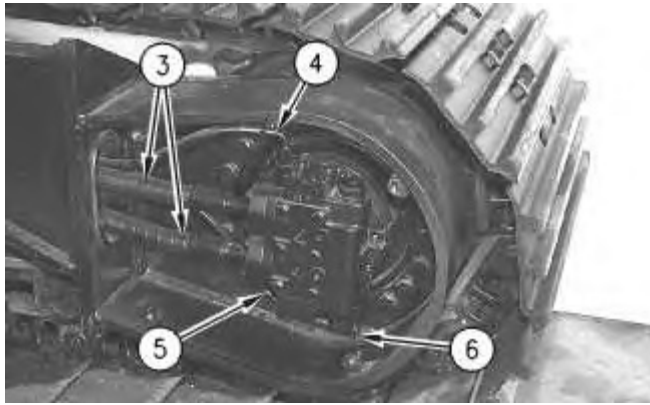

Illustration 3

g00486981

Typical example

6. Install the O-ring seal on elbow (6). Install elbow (6) in the travel motor. Tighten elbow (6) to a torque of $40 \pm 5 \text{ N}\cdot\text{m}$ ($30 \pm 4 \text{ lb ft}$). Make sure that elbow (6) is oriented properly.
7. Connect hose assemblies (4) and (5) .
8. Connect hose assemblies (3) .
9. Check the oil level in the hydraulic oil tank. Fill the hydraulic oil tank to the correct level. Refer to Operation and Maintenance Manual, "Lubricant Viscosities and Refill Capacities" for the correct filling procedures and fluid levels.
10. Start the machine and check for leaks.

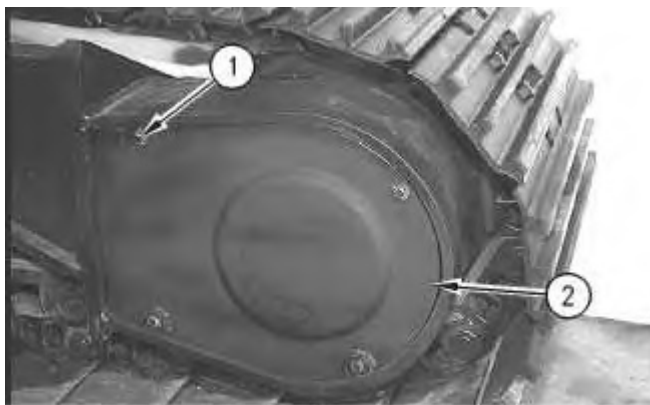

Illustration 4

g00486980

Typical example

11. Install cover assembly (2). Install the washers and bolts (1). Tighten bolts (1) to a torque of $130 \pm 10 \text{ N}\cdot\text{m}$ ($95 \pm 7 \text{ lb ft}$).

End By: Connect the track assembly. Refer to Disassembly and Assembly, "Track - Connect".

<https://www.ebooklibonline.com>

Hello dear friend!

Thank you very much for reading.

Enter the link into your browser.

The full manual is available for immediate download.

<https://www.ebooklibonline.com>