

**JOHN DEERE**  
**WORLDWIDE COMMERCIAL & CONSUMER**  
**EQUIPMENT DIVISION**

---

**Gator™ Utility Vehicles**  
**TX and TX Turf**

TM2241 SEPTEMBER 2005

**TECHNICAL MANUAL**



**JOHN DEERE**

North American Version  
Litho in U.S.A.

# INTRODUCTION

---

---

## Manual Description

This technical manual is written for an experienced technician and contains sections that are specifically for this product. It is a part of a total product support program.

The manual is organized so that all the information on a particular system is kept together. The order of grouping is as follows:

- Table of Contents
- Specifications and Information
- Identification Numbers
- Tools and Materials
- Component Location
- Schematics and Harnesses
- Theory of Operation
- Operation and Diagnostics
- Diagnostics
- Tests and Adjustments
- Repair
- Other

***NOTE: Depending on the particular section or system being covered, not all of the above groups may be used.***

The bleed tabs for the pages of each section will align with the sections listed on this page. Page numbering is consecutive from the beginning of the Safety section through the last section.

We appreciate your input on this manual. If you find any errors or want to comment on the layout of the manual please contact us.

**Safety**

**Specifications and Information**

**Engine - Gas**

**Electrical**

**Power Train**

**Steering**

**Brakes**

**Miscellaneous**

All information, illustrations and specifications in this manual are based on the latest information at the time of publication. The right is reserved to make changes at any time without notice.

COPYRIGHT© 2005  
Deere & Co.  
John Deere Worldwide Commercial and  
Consumer Equipment Division  
All rights reserved  
Previous Editions 2004, 2005  
COPYRIGHT©

# SAFETY

## Recognize Safety Information



MIF

This is the safety-alert symbol. When you see this symbol on your machine or in this manual, be alert to the potential for personal injury.

Follow recommended precautions and safe servicing practices.

## Understand Signal Words

A signal word - DANGER, WARNING, or CAUTION - is used with the safety-alert symbol. DANGER identifies the most serious hazards.

DANGER or WARNING safety signs are located near specific hazards. General precautions are listed on CAUTION safety signs. CAUTION also calls attention to safety messages in this manual.

## Replace Safety Signs

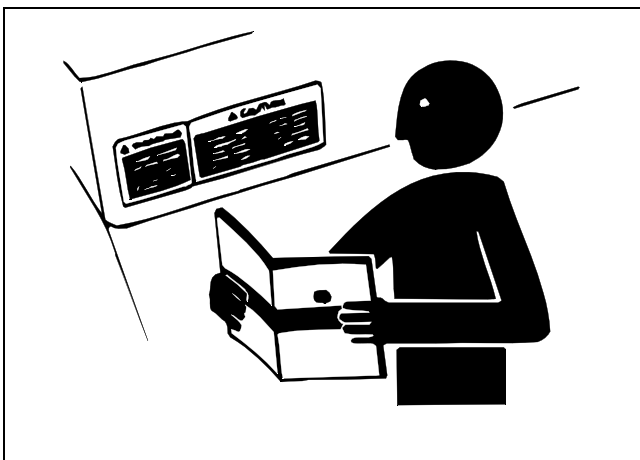

MIF

Replace missing or damaged safety signs. See the machine operator's manual for correct safety sign placement.

## Handle Fluids Safely - Avoid Fires

### Be Prepared For Emergencies

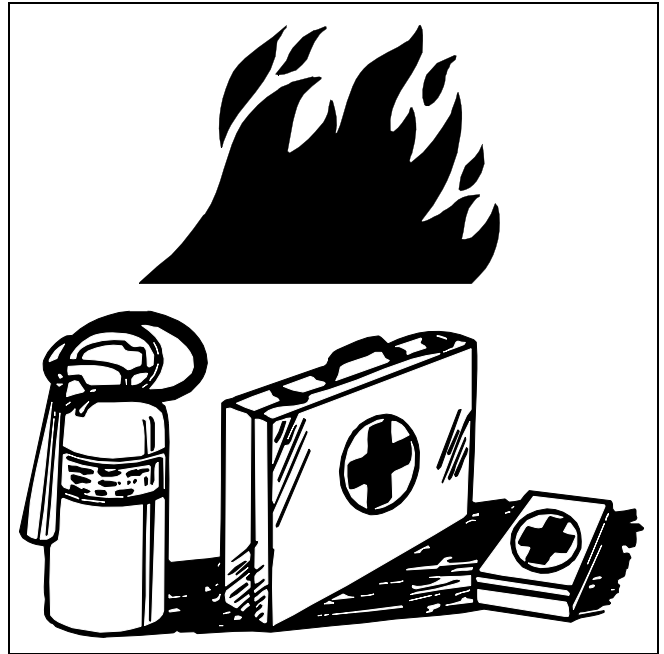

MIF

- When you work around fuel, do not smoke or work near heaters or other fire hazards.
- Store flammable fluids away from fire hazards. Do not incinerate or puncture pressurized containers.
- Make sure machine is clean of trash, grease, and debris.
- Do not store oily rags; they can ignite and burn spontaneously.
- Be prepared if a fire starts.
- Keep a first aid kit and fire extinguisher handy.
- Keep emergency numbers for doctors, ambulance service, hospital, and fire department near your telephone.

## Use Care In Handling and Servicing Batteries

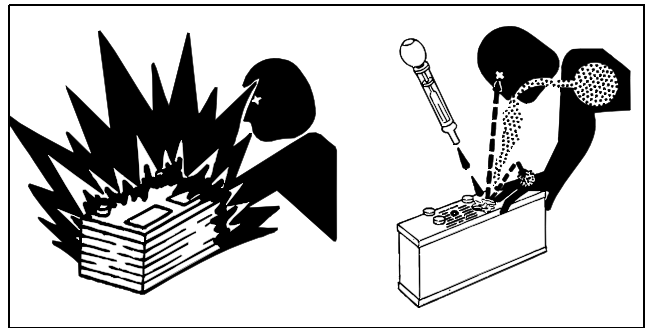

MIF

**<https://www.ebooklibonline.com>**

Hello dear friend!

Thank you very much for reading.

Enter the link into your browser.

The full manual is available for immediate download.

**<https://www.ebooklibonline.com>**

# SAFETY

## Prevent Battery Explosions

- Keep sparks, lighted matches, and open flame away from the top of battery. Battery gas can explode.
- Never check battery charge by placing a metal object across the posts. Use a volt-meter or hydrometer.
- Do not charge a frozen battery; it may explode. Warm battery to 16°C (60°F).

## Prevent Acid Burns

- Sulfuric acid in battery electrolyte is poisonous. It is strong enough to burn skin, eat holes in clothing, and cause blindness if splashed into eyes.

### Avoid acid burns by:

1. Filling batteries in a well-ventilated area.
2. Wearing eye protection and rubber gloves.
3. Avoiding breathing fumes when electrolyte is added.
4. Avoiding spilling or dripping electrolyte.
5. Use proper jump start procedure.

### If you spill acid on yourself:

1. Flush your skin with water.
2. Apply baking soda or lime to help neutralize the acid.
3. Flush your eyes with water for 10 - 15 minutes.
4. Get medical attention immediately.

### If acid is swallowed:

1. Drink large amounts of water or milk.
2. Then drink milk of magnesia, beaten eggs, or vegetable oil.
3. Get medical attention immediately.

## Wear Protective Clothing

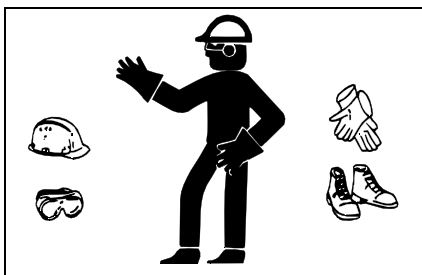

MIF

Wear close fitting clothing and safety equipment appropriate to the job.

Prolonged exposure to loud noise can cause impairment or loss of hearing. Wear a suitable hearing protective device

such as earmuffs or earplugs to protect against objectionable or uncomfortable loud noises.

Operating equipment safely requires the full attention of the operator. Do not wear radio or music headphones while operating machine.

## Use Care Around High-pressure Fluid Lines

### Avoid High-Pressure Fluids

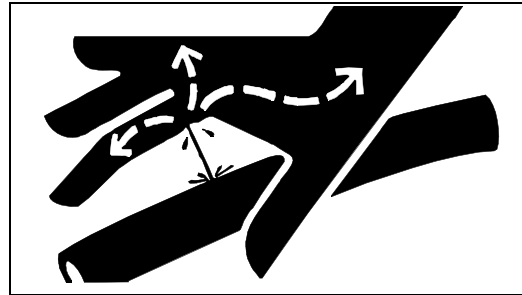

MIF

Escaping fluid under pressure can penetrate the skin causing serious injury.

Avoid injury from escaping fluid under pressure by stopping the engine and relieving pressure in the system before disconnecting or connecting hydraulic or other lines. Tighten all connections before applying pressure.

Search for leaks with a piece of cardboard. Protect hands and body from high pressure fluids.

If an accident occurs, see a doctor immediately. Any fluid injected into the skin must be surgically removed within a few hours or gangrene may result. Doctors unfamiliar with this type of injury should reference a knowledgeable medical source. Such information is available from Deere & Company Medical Department in Moline, Illinois, U.S.A.

### Avoid Heating Near Pressurized Fluid Lines



MIF

Flammable spray can be generated by heating near pressurized fluid lines, resulting in severe burns to yourself and bystanders. Do not heat by welding, soldering, or using a torch near pressurized fluid lines or other flammable materials. Pressurized lines can be accidentally cut when heat goes beyond the immediate flame area.

# SAFETY

## Service Machines Safely

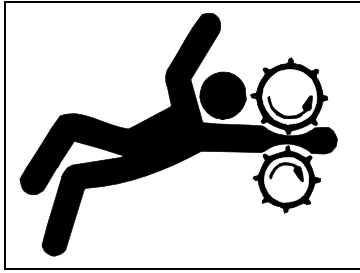

MIF

Tie long hair behind your head. Do not wear a necktie, scarf, loose clothing, or necklace when you work near machine tools or moving parts. If these items were to get caught, severe injury could result.

Remove rings and other jewelry to prevent electrical shorts and entanglement in moving parts.

## Use Proper Tools

Use tools appropriate to the work. Makeshift tools and procedures can create safety hazards. Use power tools only to loosen threaded parts and fasteners. For loosening and tightening hardware, use the correct size tools. **DO NOT** use U.S. measurement tools on metric fasteners. Avoid bodily injury caused by slipping wrenches. Use only service parts meeting John Deere specifications.

## Parking Safely

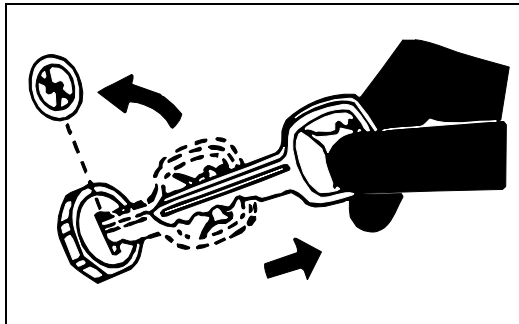

MIF

1. Stop machine on a level surface, not on a slope.
2. Disengage and stop attachments.
3. Lower attachments to the ground.
4. Lock park brake.
5. Stop engine.
6. Remove key.
7. Wait for engine and all moving parts to stop before you leave the operator's station.
8. Close fuel shut-off valve, if your machine is equipped.

## Support Machine Properly and Use Proper Lifting Equipment

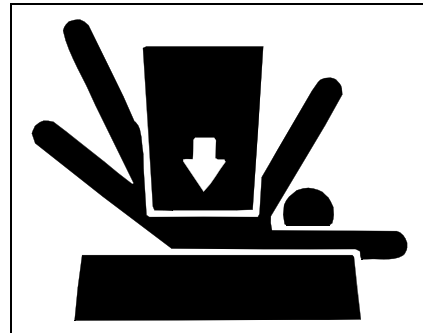

MIF

If you must work on a lifted machine or attachment, securely support the machine or attachment.

Do not support the machine on cinder blocks, hollow tiles, or props that may crumble under continuous load. Do not work under a machine that is supported solely by a jack. Follow recommended procedures in this manual.

Lifting heavy components incorrectly can cause severe injury or machine damage. Follow recommended procedure for removal and installation of components in the manual.

## Work In Clean Area

### Before starting a job:

1. Clean work area and machine.
2. Make sure you have all necessary tools to do your job.
3. Have the right parts on hand.
4. Read all instructions thoroughly; do not attempt shortcuts.

## Using High Pressure Washers

Directing pressurized water at electronic/electrical components or connectors, bearings, hydraulic seals, fuel injection pumps or other sensitive parts and components may cause product malfunctions. Reduce pressure and spray at a 45 to 90 degree angle.

## Illuminate Work Area Safely

Illuminate your work area adequately but safely. Use a portable safety light for working inside or under the machine. Make sure the bulb is enclosed by a wire cage. The hot filament of an accidentally broken bulb can ignite spilled fuel or oil.

# POWER TRAIN - GEAR TESTS AND ADJUSTMENTS

## System: Primary and Secondary Clutch

**No** - Repair or replace drive and/or secondary clutches.

## Tests and Adjustments

### Transaxle Shift Adjustment

#### Reason:

- To insure gear shift lever is centered in neutral when transaxle is in neutral.
- To insure both forward and reverse gears will be completely engaged.
- To help prevent shifter from disengaging from gear during operation.

#### Procedure:

1. Park machine safely. See "Parking Safely" on page 3 of the Safety Section.
2. Raise and lock the cargo box.
3. Move shift lever until detent inside transaxle clicks firmly into the center neutral position.

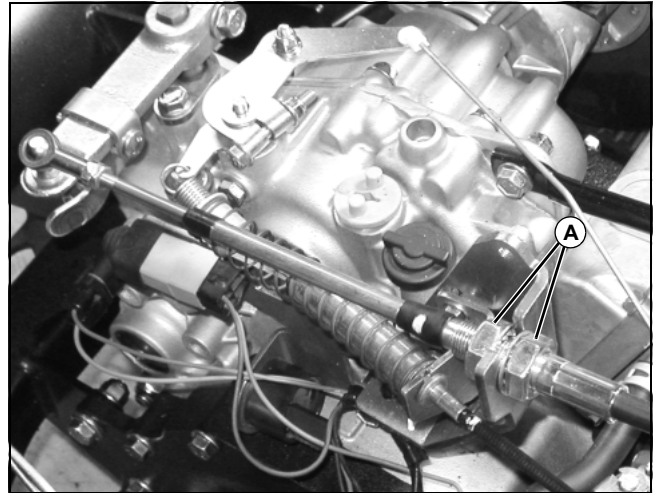

MX34117

**Picture Note: TX Turf Gators**

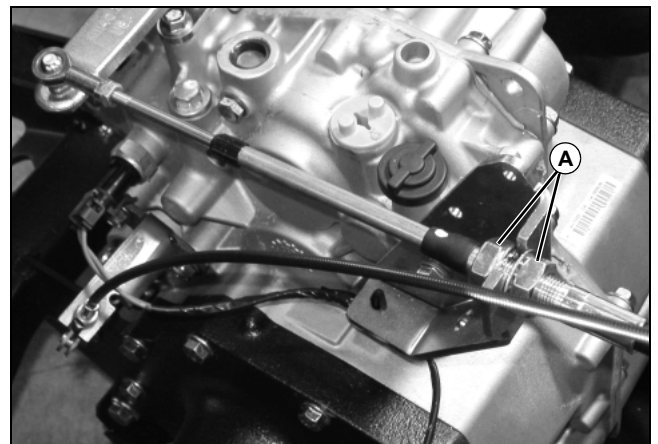

MX34118

**Picture Note: TX Gators**

# POWER TRAIN - GEAR TESTS AND ADJUSTMENTS

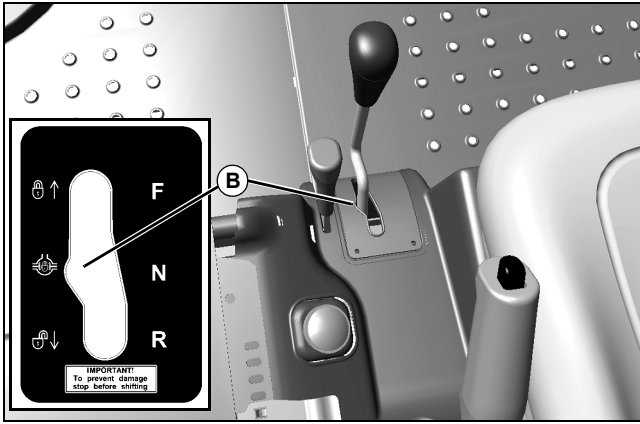

M151644, MX32938

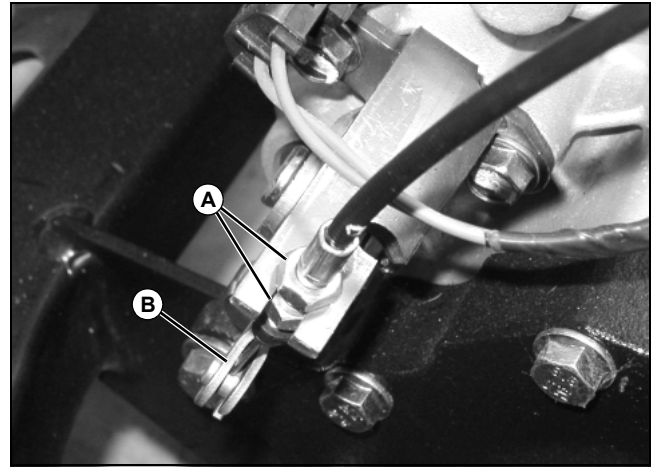

MX34119

4. Loosen shift rod nuts (A) as necessary. Adjust the shift rod nuts so the shift lever is centered in the shifter quadrant in the neutral position (B).
5. Tighten the shift rod nuts.
6. Shift into neutral and check neutral start.

8. Loosen the differential lock cable adjusting nuts (A), and adjust so that all slack in the cable is removed without pulling on the differential lock arm (B).
9. Tighten differential lock cable adjusting nuts (A).

## Differential Lock Cable Adjustment - TX

### Reason:

To insure complete disengagement and engagement of differential lock.

### Procedure:

1. Park the vehicle safely. (See Parking Safely in the SAFETY section.)
2. Raise and secure cargo box.
3. Chock the left side wheels.
4. Unlock the park brake.
5. Place the differential lock lever in disengaged position.
6. Safely jack-up and support the right rear side wheel just enough to allow the wheel to rotate while the left side wheels remain firmly on the ground.
7. By hand, rotate right side drive wheel. Wheel should rotate freely with no clicking sound in transaxle. Differential should be disengaged.

## Drive Train Performance Tests

### Engagement and Full Up-Shift Check



**CAUTION: Avoid Injury! When operating machine to observe drive train performance, always operate in an area flat and free of obstacles. Use a passenger to observe power train so you can concentrate on driving safely. Never back machine with cargo box raised.**

### Reason:

To determine if the engine and drive train are operating at peak performance.

### Conditions:

- Engine slow idle and fast idle speed set correctly
- Drive belt width at or above minimum specification
- Engine warmed up

### Procedure:

1. Transaxle in neutral and park brake set. Start engine.
2. Slowly increase engine rpm. Observe engine rpm when clutch starts to engage and move drive belt.

# POWER TRAIN - GEAR TESTS AND ADJUSTMENTS

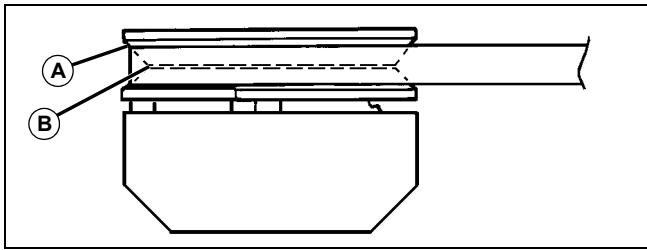

MX0763

3. Accelerate from idle to wide-open-throttle and back to idle several times. Watch drive belt for a smooth transition from bottom to top of primary clutch (A). Watch closely for any hesitation or engine surging. Observe gap between primary clutch movable sheave and stationary sheave. Gap should completely close (B).

4. When approaching idle, watch for a positive disengagement from drive belt.

**NOTE: On clutches with some hours of use, system may not disengage as smoothly due to primary clutch spring taking a set and wear in the drive components.**

5. Shut off engine.

## Result:

- With transaxle in gear, clutch should slowly start to engage and move drive belt between 1350 - 1600 rpm. Drive belt should be riding high in primary clutch and low in secondary clutch.
- If clutch has harsh engagement, erratic transition, hesitation, or clutch noise, check primary clutch for cam weights binding, pivot pins worn, flat spots on rollers or rollers sticking, and no groove in sheave. Repair or replace primary clutch.
- If engine is surging, check engine and governor performance.
- Smooth engagement and transition (up-shift), primary clutch is good. Go to "Driven Clutch Back-Shifting Check".

## Driven Clutch Back-Shifting Check

### Reason:

To determine condition of driven clutch and back-shifting performance.

### Conditions:

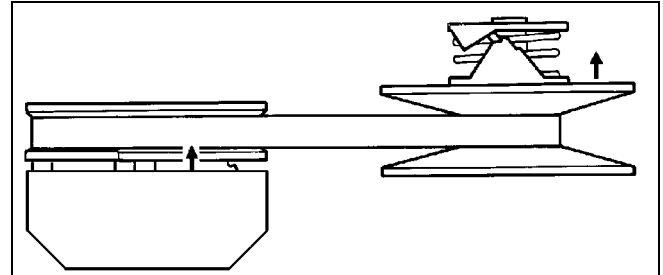

MX0764

- Raise and lock the cargo box.
- Indoor testing - rear wheels off ground and machine supported safely on jack-stands.
- Front wheels chocked
- Differential lock engaged
- Tachometer displaying engine speed

### Procedure:



**CAUTION: Avoid Injury! Rear wheels will rotate during test. Keep clear!**

1. Start engine.
2. Put transaxle in gear.
3. Operate engine at wide open throttle.

### Results:

- Engine and wheel speed should remain at constant speed. Drive belt should be riding high in primary clutch and low in secondary clutch.

### Procedure:

1. Momentarily load power train by slowly applying brake or park brake until back-shift is made.
2. Quickly observe engine speed, then release brake.

### Results:

- Clutches should back-shift as load is increased.
- Drive belt should not squeal or slip.
- Check secondary clutch for complete up-shift. Check for load on drive train, such as an engaged brake or failed axle bearings. See "Park Brake Adjustment" on page 293 in the Brakes section.

# POWER TRAIN - GEAR REPAIR

## Repair

### Drive Clutch Removal and Installation

**CAUTION:** Avoid injury! Touching hot surfaces can burn skin. The engine, components, and fluids will be hot if the engine has been running. Allow the engine to cool before servicing or working near the engine and components.

1. Park the vehicle safely. (See Parking Safely in the SAFETY section.)
2. Allow engine to cool completely.
3. Raise and secure cargo box.
4. Remove drive belt.

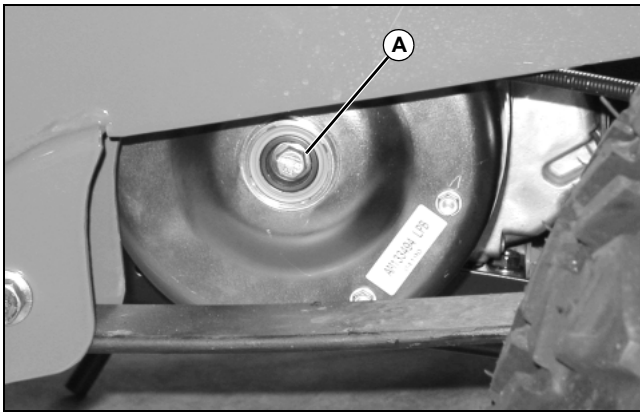

MX34098

5. Remove clutch mounting bolt and washer (A).

**NOTE:** Grease the threads and end of clutch removal tool before each use.

**Use an impact wrench to remove the drive clutch.**

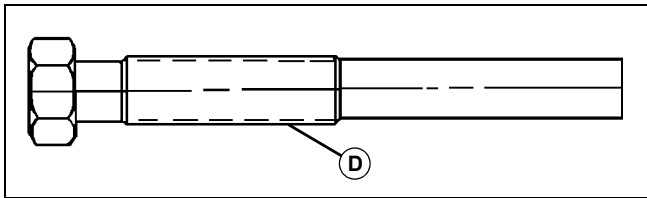

M58704

6. Use JDG1641 Clutch Removal Tool (D). Thread puller into clutch and against crankshaft. Tighten until clutch pops free from crankshaft taper.
7. Install clutch in reverse order of removal. Tighten clutch bolt to specification.

#### Specification:

**Drive Clutch Bolt** ..... 37 N•m (27 lb-ft)

### Driven Clutch Removal and Installation

#### Removal:

**CAUTION:** Avoid injury! Touching hot surfaces can burn skin. The engine, components, and fluids will be hot if the engine has been running. Allow the engine to cool before servicing or working near the engine and components.

1. Park the vehicle safely. (See Parking Safely in the SAFETY section.)
2. Allow engine to cool completely.
3. Raise and secure cargo box.
4. Block front wheels.
5. Remove drive belt.

**IMPORTANT:** Avoid damage! If needed, a pry bar may be placed within the clutch slide shaft area. If this method is used, do not nick or scratch the slide shaft.

**NOTE:** Use an air impact wrench to remove the driven clutch bolt.

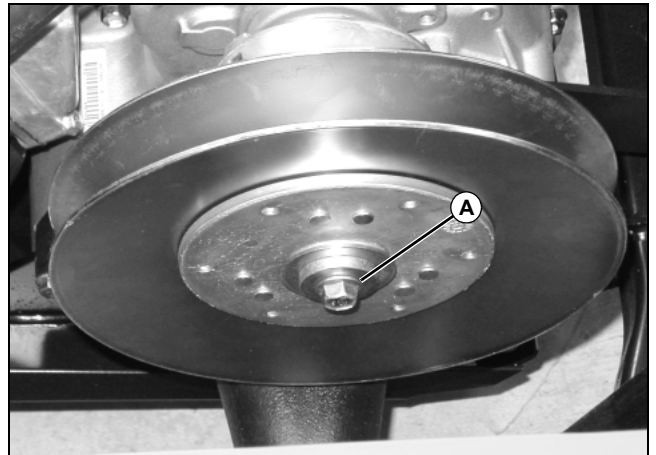

MX34099

6. Remove driven clutch cap screw and washer (A). Remove driven clutch.

#### Installation:

Installation is done in the reverse order of removal.

1. Install driven clutch, washer and cap screw. Tighten cap screw to specification.
2. Install drive belt.

#### Torque Specification:

**Driven Clutch Cap Screw** .. 73 ± 14 N•m (54 ± 10 lb-ft)

# POWER TRAIN - GEAR REPAIR

## Drive Clutch Disassembly and Assembly

### Special or Required Tools

Tool Name	Tool No.	Tool Use
Clutch Removal Tool	JDG1641	Clutch puller screw to remove drive clutch from tapered fit on engine crankshaft.
Holding Tool	JDG1862-1	To hold drive clutch during removal of drive clutch spider.
Spanner Wrench	JDG1862-2	To remove drive clutch spider.
Holding Fixture Bolt	215348	Bolt used to hold stationary sheave in vice during disassembly and assembly.

### Disassembly:

**NOTE: The clutch cover is a bearing for the clutch center shaft. Before removing clutch cover, mark cover and clutch to help in installing the cover in the same position.**

1. Remove clutch cover bolts. Remove cover. (Cover should pop off; do not pry on cover).

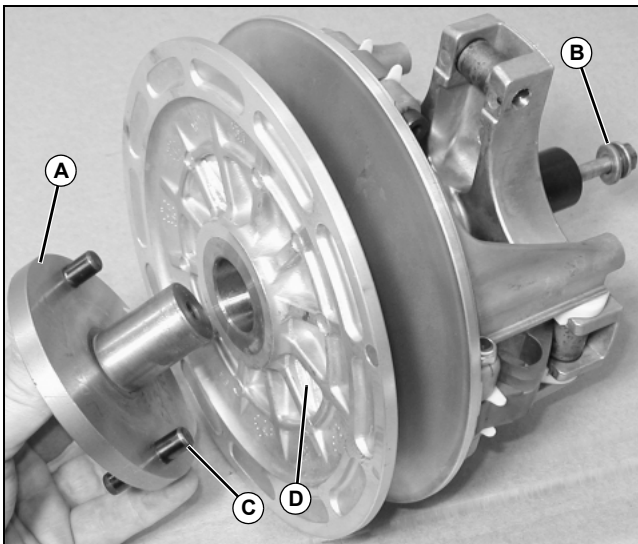

MX34129

2. Install JDG1862-1 Holding Tool (A) and retain it with a M10 X 1.5 X 150 mm hex-head bolt (B). Allow the pins (C) to engage into the clutch casting notches (D).

**IMPORTANT: Avoid damage! Always use spider wrench to remove spider. Unequal pressure on clutch towers could cause stress fractures or break them off. A high strength thread lock is used on spider threads.**

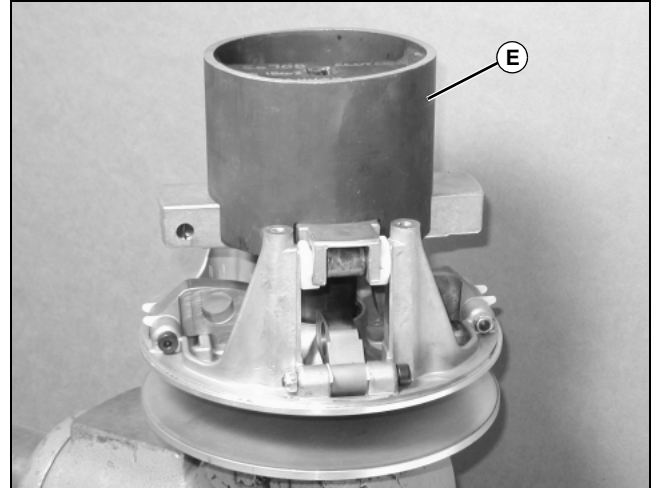

MX34130

3. Clamp the holding tool and clutch into a vise and use JDG1862 Spanner Wrench (E) to remove spider.

### Inspection:

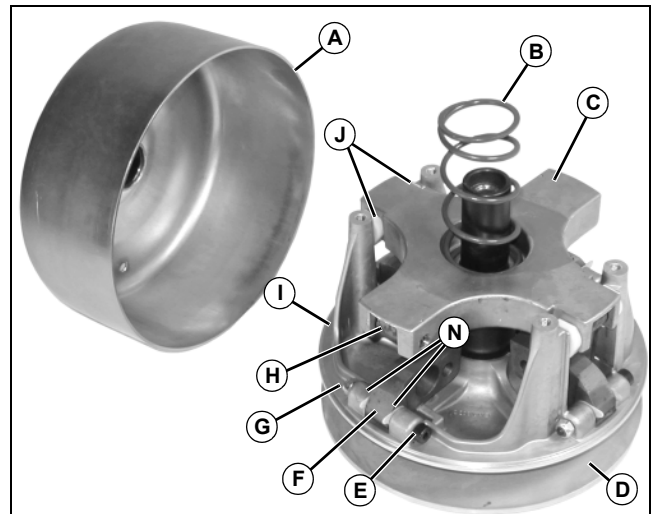

MX34104

# POWER TRAIN - GEAR REPAIR

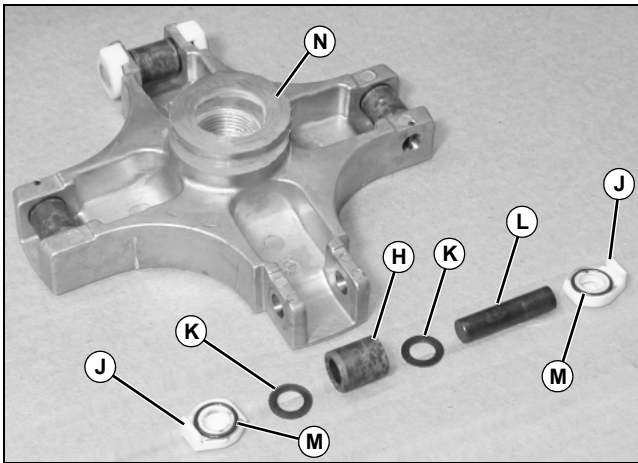

MX36063

- A - Clutch Cover
- B - Spring
- C - Spider
- D - Stationary Sheave
- E - Pivot Bolt
- F - Flyweight
- G - Nut
- H - Roller
- I - Sliding Clutch Sheave
- J - Slide Pads
- K - Spacer
- L - Roller Pin
- M - O-Ring
- N - Spacer

**NOTE: When cleaning and assembling clutch components, do not use lubrication on any parts. Lubricants can bind with dust and cause sticking and premature wear.**

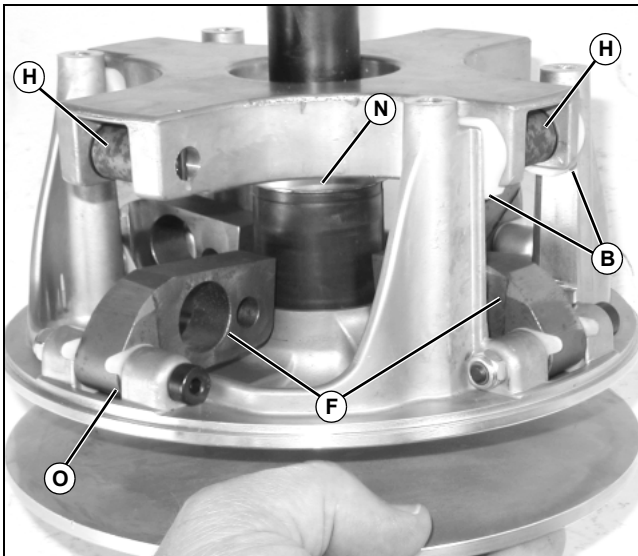

MX34105

1. Wear eye protection and blow out dust and dirt particles from clutch parts with compressed air.
2. Check spider rollers (H) for flat spots or binding.
3. Check flyweights (F) for binding.

**NOTE: Do not lubricate clutch components.**

4. Clean flyweight pivot area (O). Remove pivot bolts and clean pivot area. Replace bolt if worn through plating.
5. Clean and inspect the clutch sheave slide shaft (N). Replace clutch if shaft is worn, scratched or pitted.
6. With stationary sheave down on workbench, sliding sheave should drop by it's own weight.

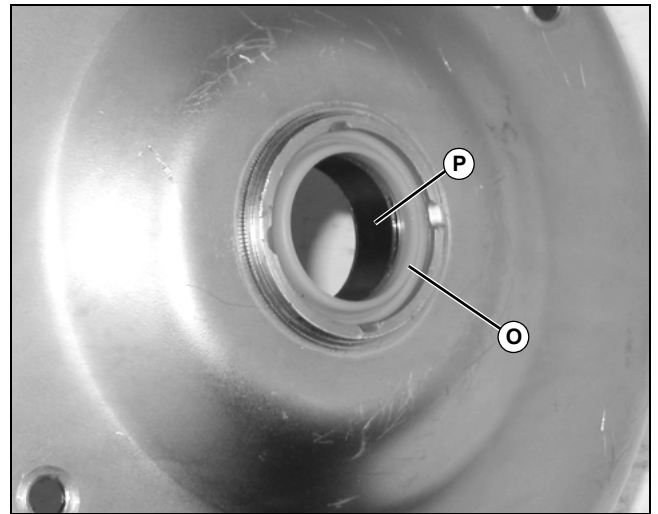

MX34106

7. Inspect the clutch cover dust seal (O) and bushing (P) for wear, nicks, or scratches. Replace clutch cover as needed.
8. Reassemble components.

## Assembly:

Assembly is done in the reverse of disassembly.

- Apply high strength thread lock to spider threads.
- Assemble components. Tighten spider to **170 N•m (125 lb-ft)**.

# POWER TRAIN - GEAR REPAIR

## Driven Clutch Disassembly and Assembly

### Disassembly:

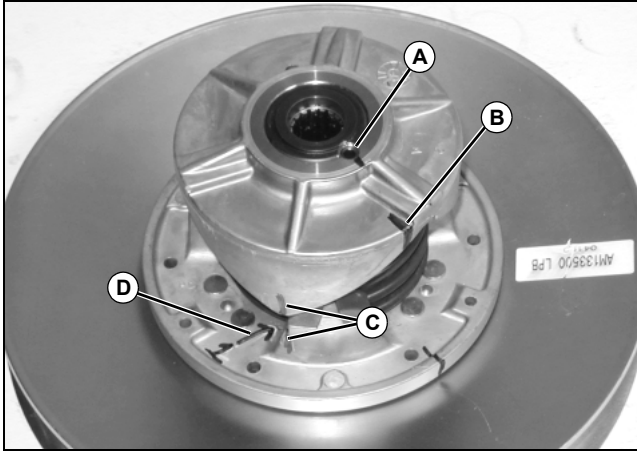

MX34087

1. Mark location of set screw (A) on the outer edge of the cam (B).
2. Place alignment marks (C) on cam and movable sheave to aid in assembly.
3. Mark the location of the spring tab in the movable sheave (D).
4. Remove set screw (A).



**CAUTION: Avoid Injury! Hold cam securely to prevent sudden spring release**

**NOTE: Cam is press fit on shaft. Use a three-jaw puller and an impact wrench, at low speed, to remove cam from shaft.**

5. Use a three-jaw puller to pull the cam off of the shaft.
6. Remove cam, spring, and movable sheave from shaft.

### Inspection:

**NOTE: Ramp shoes are mounted with tabs on backside. Tabs are interference fit into holes on face of ramps. Remove shoes only if replacement is necessary.**

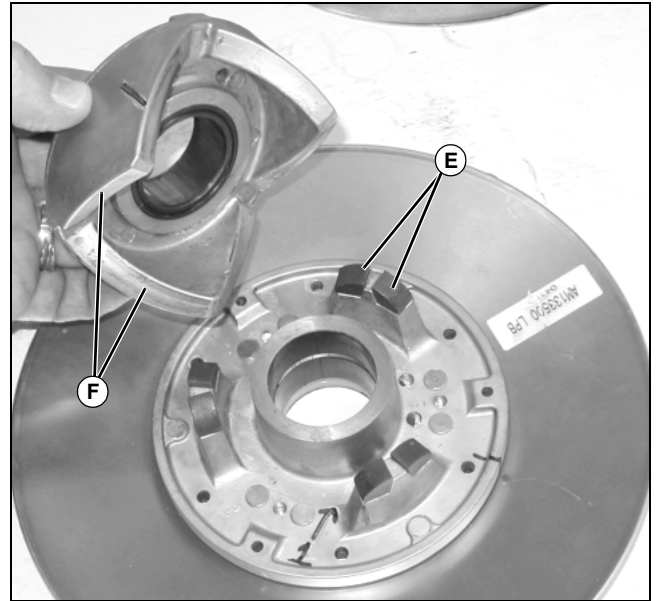

MX34088

1. Inspect ramp shoes (E) for wear or cracks.
2. Inspect the ramps (F) for nicks or scratches.

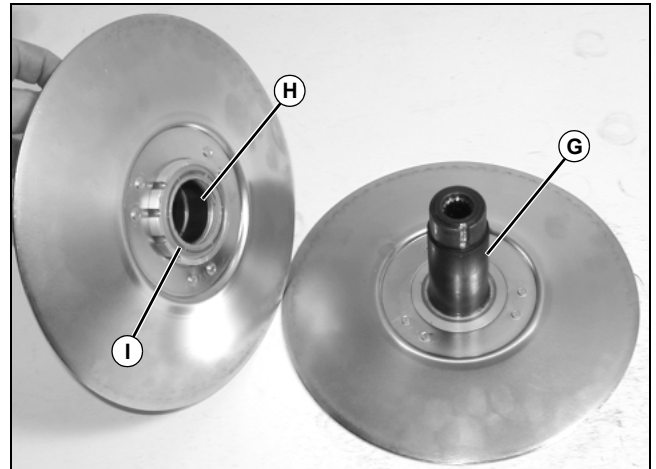

MX34089

3. Inspect sheave shaft (G) and bore (H) for wear, nicks, or scratches.
4. Inspect movable sheave seal (I) for wear or damage.
5. Replace any damaged components as needed.

### Assembly:

1. Install movable sheave on fixed sheave.
2. Install spring. Insert spring tab into previously marked hole in movable sheave and hole in cam.

# POWER TRAIN - GEAR REPAIR

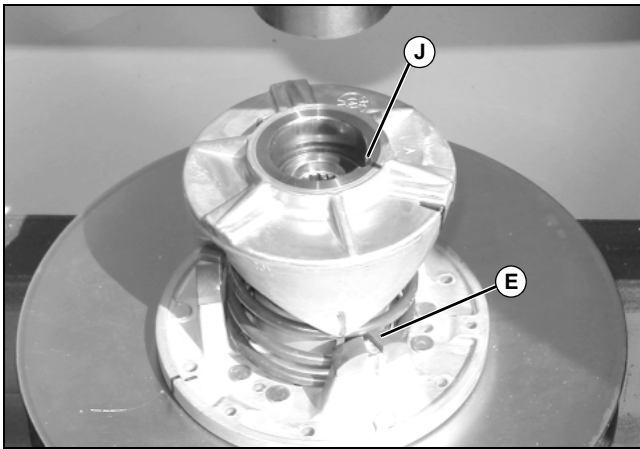

MX34090

3. Align set screw bores (J) and press cam on shaft until cam lobe almost touch ramp shoes (E).

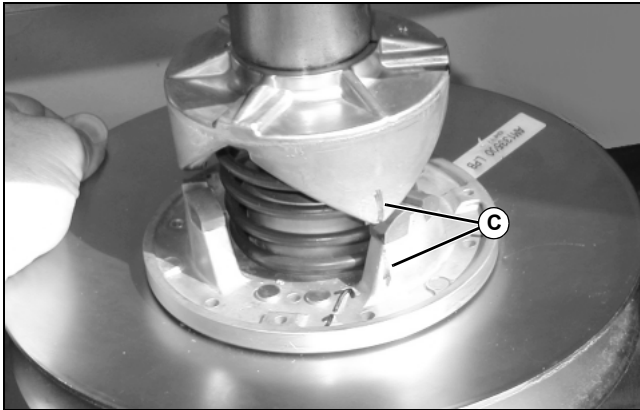

MX34091

4. Rotate the movable sheave until the marks (C) are aligned and continue to press the cam onto the shaft until fully seated.

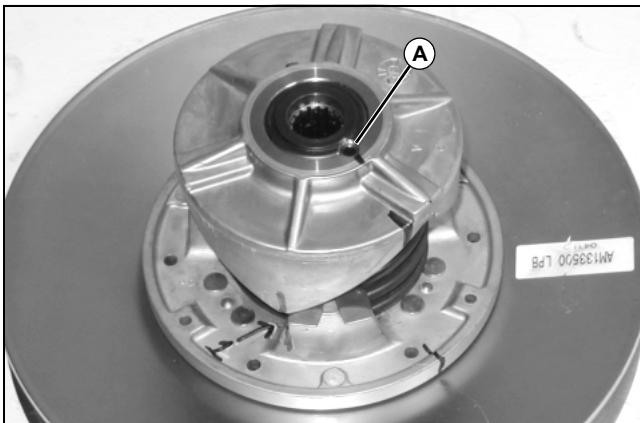

MX34087

5. Apply thread lock and sealer (medium strength) to threads of set screw (A) and install.

6. After clutch in installed, check clutch operation. See "Driven Clutch Back-Shifting Check" on page 237.

## Driven Clutch Ramp Button Replacement

1. Park the vehicle safely. (See Parking Safely in the SAFETY section.)
2. Raise and secure cargo box, or remove cargo box.

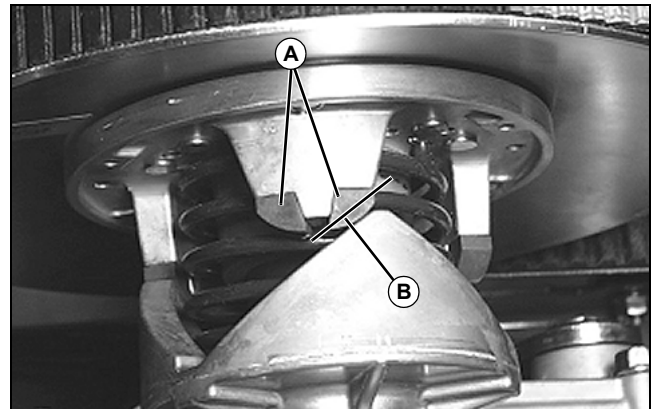

MX33643

3. Check for missing or worn clutch buttons (A).
  - There should not be excessive wear (B), or any metal-to-metal contact.
  - If replacement is necessary, continue with procedure.
4. Remove drive belt.
5. Turn moveable sheave until buttons are away from ramps. Install small block of wood between other ramps and buttons to hold sheave half in position.

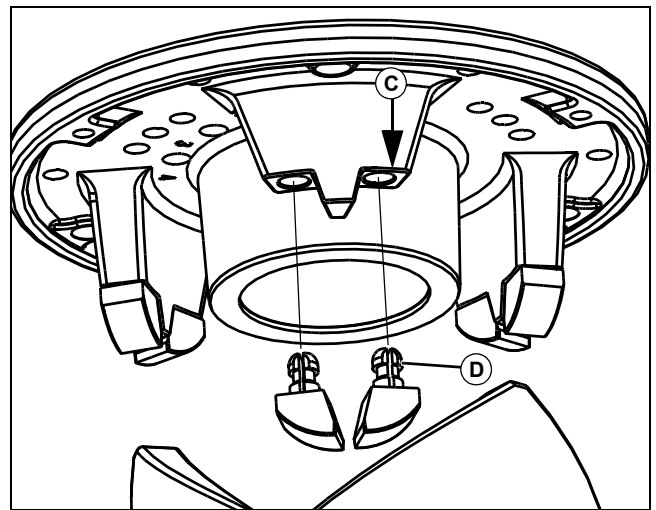

mif

6. Pry the button away from moveable sheave (C) until the button locks (D) break off and the button falls out.

The lock portion of the button will stay inside the casting.

7. Install new button. Push button straight in with a screwdriver by prying against cam.

8. Install drive belt.

9. Lower the cargo box.

# POWER TRAIN - GEAR REPAIR

## Transaxle Removal and Installation

### Removal:

1. Park machine safely. See "Parking Safely" on page 3 of the Safety Section.
2. Block front wheels to prevent machine from rolling.
3. Drain the transaxle fluid into an adequate container. When drained, install drain plug to specification.
4. Remove cargo box. See "Cargo Box Removal and Installation" on page 310 in the Miscellaneous section.
5. Remove drive belt.
6. Remove engine from machine. See "Engine Removal and Installation" on page 49.

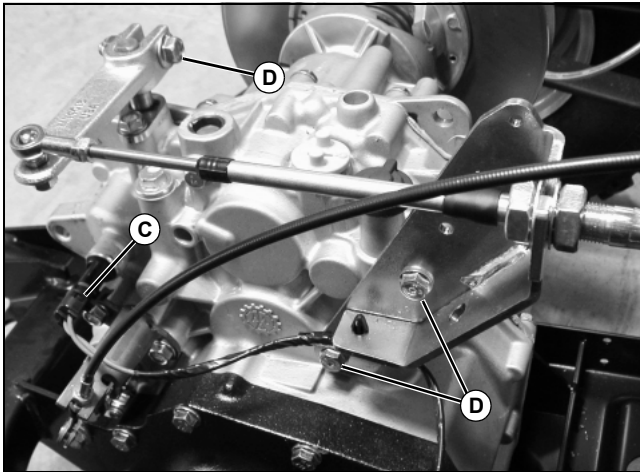

MX34159

### 7. TX Machines:

- a. Disconnect connector (C) from neutral start switch.
- b. Loosen clamp bolt (D) on shift arm and slide shift arm off of shaft.
- c. Remove the two cap screws (E) securing the shift cable bracket to the transaxle. Move the shift cable and neutral wires clear of the transaxle.

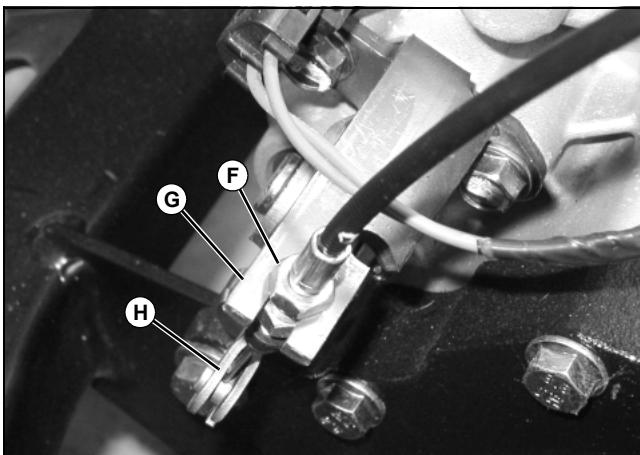

MX34119

- d. Loosen jam nut (F) on differential lock cable. Slide cable out of bracket (G) and disconnect cable end from arm (H) on transaxle.

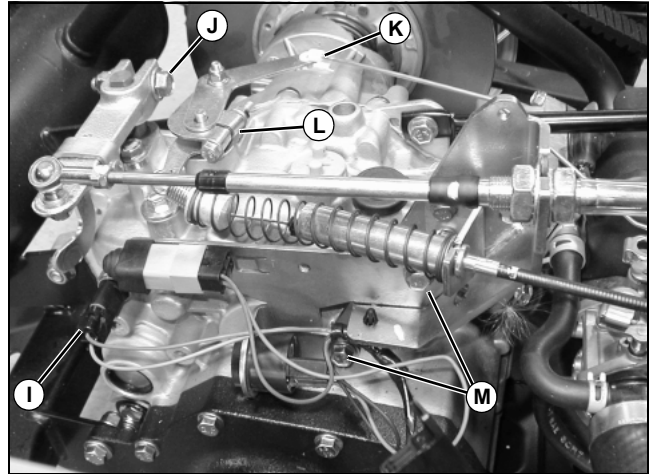

MX34160

### 8. TX Turf Machines:

- a. Disconnect connector (I) from neutral start switch.
- b. Loosen clamp bolt (J) on shift arm and slide shift arm off of shaft.
- c. Remove the clamp (K) on governor arm and remove the governor link.
- d. Loosen clamp bolt (L) on governor arm and slide governor arm off of shaft.
- e. Remove the two cap screws (M) securing the shift cable bracket to the transaxle. Move the shift cable and wire harness clear of the transaxle.

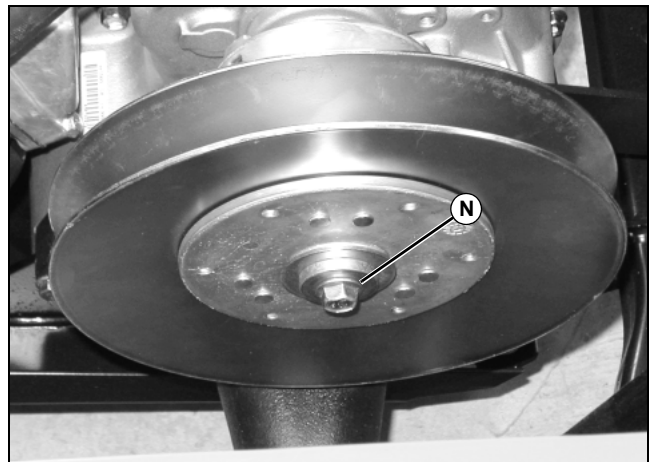

MX34099

9. Remove driven clutch cap screw and washer (N). Remove driven clutch.
10. Raise and support rear of machine safely on stands.
11. Release the park brake.
12. Remove rear wheels. See "Wheel Removal and

# POWER TRAIN - GEAR REPAIR

Installation” on page 309 in the Miscellaneous section.

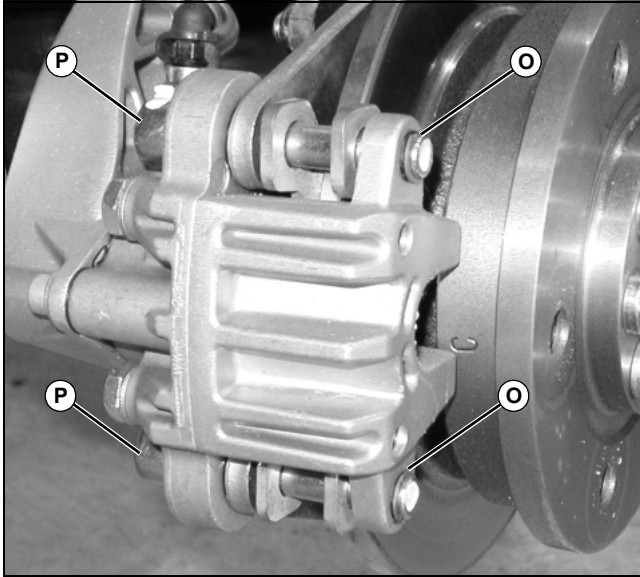

MX34161

13. Remove the C-clips (O) from the caliper slide bolts (P).

**NOTE: It is not necessary to disconnect hydraulic brake line from caliper.**

14. Remove the caliper slide bolts (P) and move the rear brake calipers clear of the rear axle ensuring the stress is taken off of the brake line. Repeat on other side of machine.

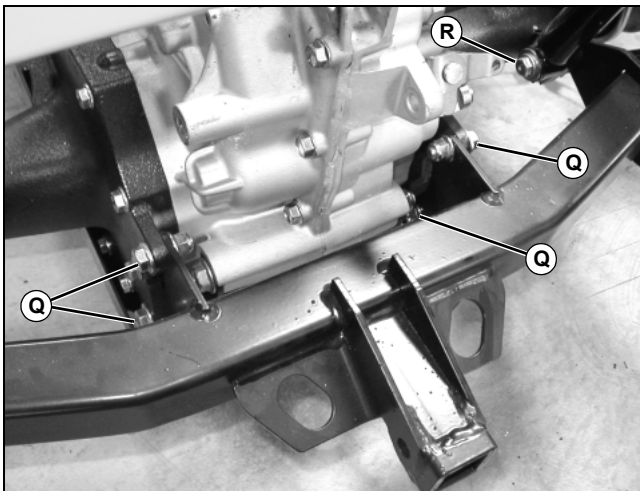

MX34162

15. Remove the four cap screws and lock nuts (Q) securing the trailer hitch to the transaxle.

16. Remove the two cap screws and lock nuts (R) (one on each side of machine), securing the shock, hitch and transaxle together. Remove trailer hitch.

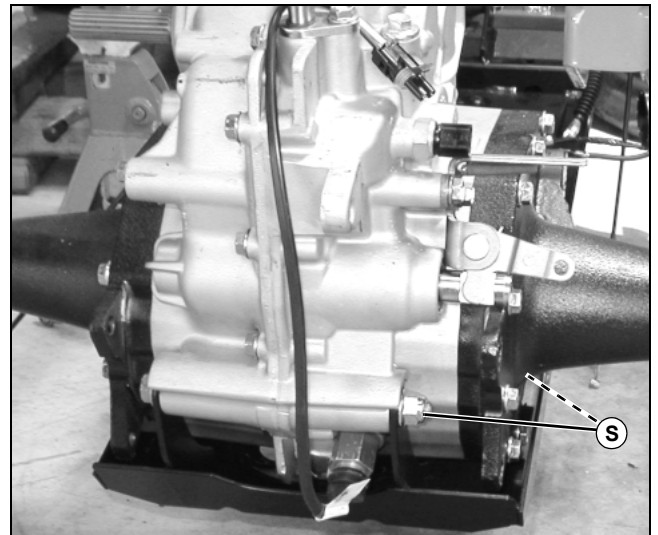

MX34163

**Picture Note: Rear transaxle to carrier mounting cap screw shown. Front mounting cap screw is similar.**

17. Remove the two cap screws and lock nuts (S) securing the transaxle to the carrier and allow the carrier to pivot down to the floor.

18. Place a floor-jack securely under the transaxle for support during removal.

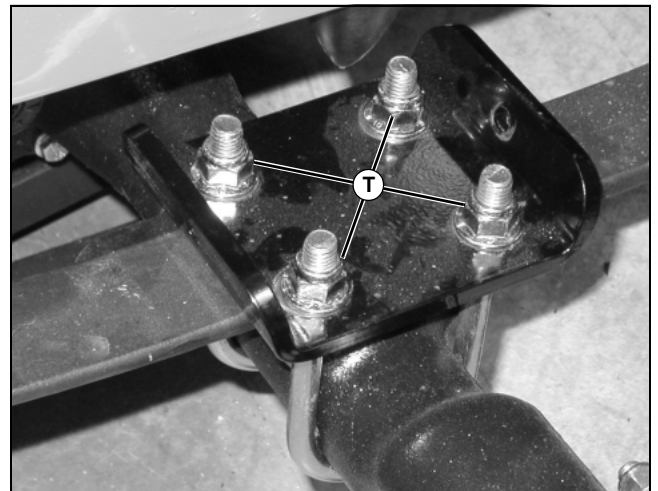

MX34164

19. Remove the four lock nuts (T) securing the transaxle to the spring. Repeat for the opposite side.

20. Lower the transaxle enough to clear the springs and frame and remove transaxle from machine.

# POWER TRAIN - GEAR REPAIR

## Installation:

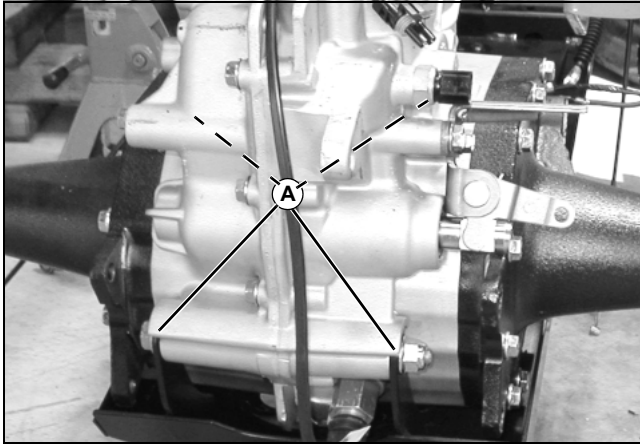

MX34163

1. Place transaxle on the carrier. Make sure the weight of the transaxle is resting on all four locating tabs (A) before installing and tightening bolts. Tighten bolts to specification.

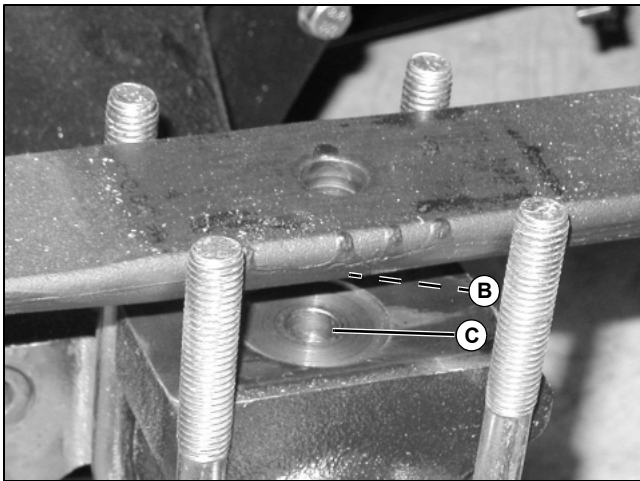

MX34165

2. Raise the transaxle carrier into position and align locating pin on spring (B) with hole in axle (C).

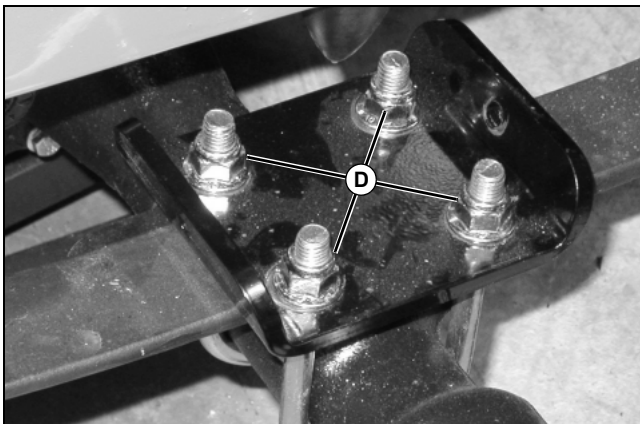

MX34164

3. Install the retainer plate, u-bolts, and four lock nuts (D) securing the transaxle to the spring. Repeat for the

opposite side.

4. Tighten the lock nuts evenly and torque to specification.

5. Remove the floor-jack.

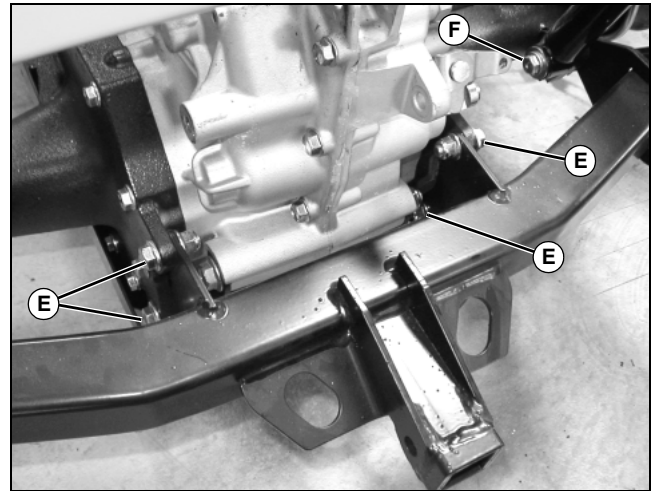

MX34162

6. Position the trailer hitch onto the transaxle and install the four cap screws and lock nuts (E) securing the trailer hitch to the transaxle. Tighten the lock nuts to specification.

7. Install the two cap screws and lock nuts (F) (one on each side of machine), securing the shock, hitch and transaxle together. Tighten the lock nuts to specification.

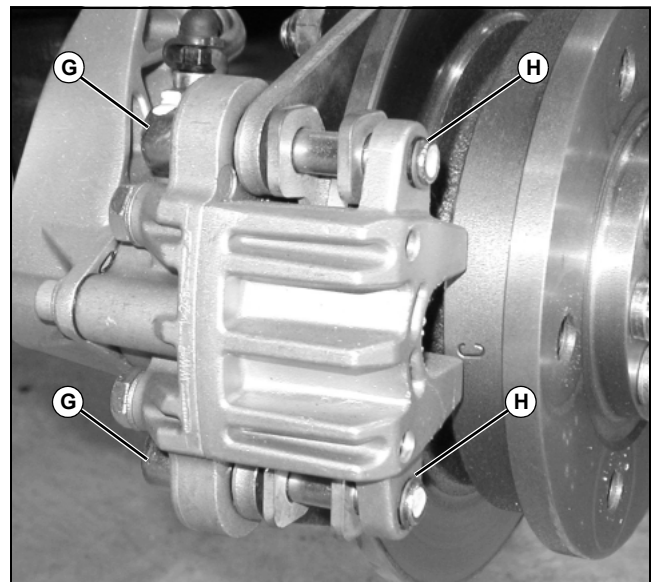

MX34161

8. Position the caliper over the brake disc, aligning the slide bolt mounting holes. Install the caliper slide bolts (G) and tighten to specification. Repeat on other side of machine.

9. Install the C-clips (H) on to the caliper slide bolts (G).

10. Install the rear wheels. See "Wheel Removal and Installation" on page 309 in the Miscellaneous section.

# POWER TRAIN - GEAR REPAIR

11. Lock the park brake.

12. Safely remove the support stands and lower the machine to the floor.

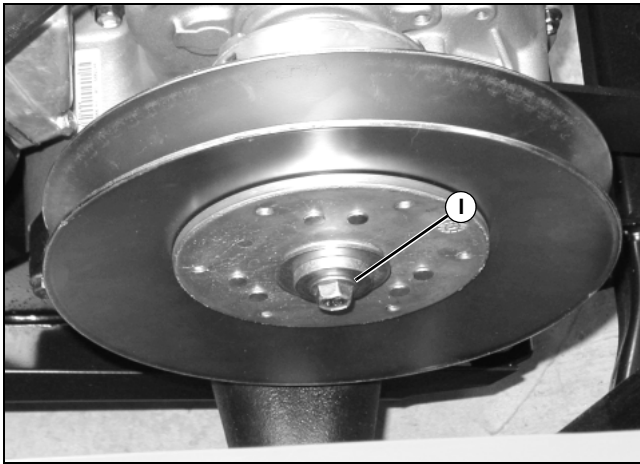

MX34099

13. Install the driven clutch cap screw and washer (I) and tighten to specification.

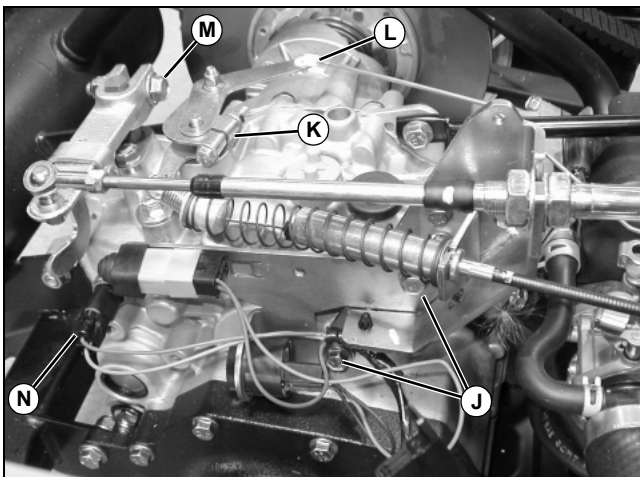

MX34160

14. TX Turf Machines:

- Position the shift cable bracket to the transaxle and install the two cap screws (J). Tighten to specification.
- Turf - Install the governor arm onto the transaxle governor shaft and tighten the clamp bolt (K) to specification.
- Turf - Install the governor link and secure in place with clamp (L).
- Turf - Install the shift arm onto the shift shaft and tighten the clamp bolt (M) to specification.
- Turf - Connect the wire harness connector (N) to the neutral start switch.

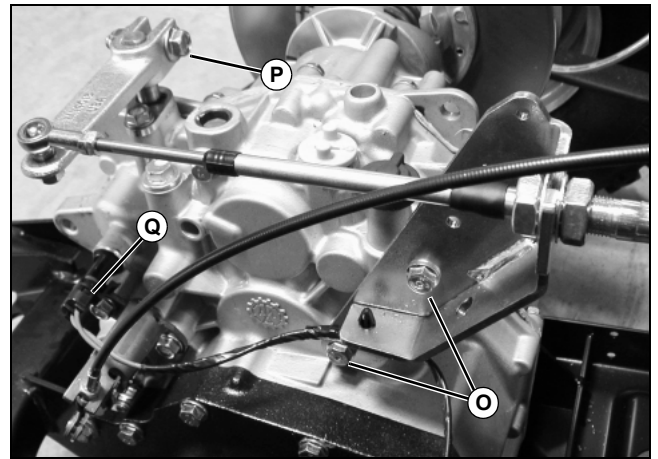

MX34159

15. TX Machines:

- Position the shift cable bracket to the transaxle and install the two cap screws (O). Tighten to specification.
- Install the shift arm onto the shift shaft and tighten the clamp bolt (P) to specification.
- Connect the wire harness connector (Q) to the neutral start switch.

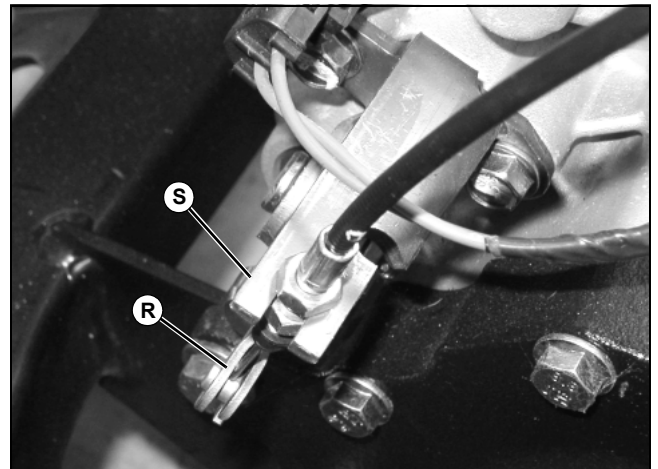

MX34119

- Install the differential cable into the shift arm (R) and then the mounting bracket (S).
- Adjust the differential lock cable. See "Differential Lock Cable Adjustment - TX" on page 236.

16. Install engine in machine. See "Engine Removal and Installation" on page 49.

17. Fill the transaxle with 5.23 L (5.5 qt) of John Deere Low Viscosity HY-GARD® J20D fluid.

18. Install muffler. See "Muffler Removal and Installation" on page 44.

19. Install drive belt.

20. Install cargo box. See "Cargo Box Removal and Installation" on page 310 in the Miscellaneous section.

# POWER TRAIN - GEAR REPAIR

## Torque Specifications:

Transaxle U-bolts . . . . .	130 N•m (96 lb-ft)
Transaxle to Carrier Nuts . . . . .	130 N•m (96 lb-ft)
Trailer Hitch to Transaxle Bolts . . . . .	80 N•m (59 lb-ft)
Shock Absorber Bolt . . . . .	73 ± 10 N•m (54 ± 7 lb-ft)
Caliper Sliding Pins . . . . .	41 - 52 N•m (30 - 38 lb-ft)
Driven Clutch Cap Screw . . . . .	73 N•m (54 lb-ft)
Shift Cable Bracket Cap Screws . . . . .	23 N•m (17 lb-ft)
Governor Arm Clamp Bolt . . . . .	17 N•m (12 lb-ft)
Shift Arm Clamp Bolt . . . . .	50 N•m (37 lb-ft)
Strut to Engine Nuts . . . . .	32 N•m (24 lb-ft)
Strut to Transaxle Nuts . . . . .	37 N•m (27 lb-ft)
Muffler Bracket Cap Screws . . . . .	20 N•m (15 lb-ft)
Muffler Flange Nuts . . . . .	15 N•m (11 lb-ft)
Drain Plug . . . . .	30 - 35 N•m (22 - 26 lb-ft)
Transaxle Oil Capacity . . . . .	5.23 L (5.5 qt)

## Axle Housing Removal and Installation

### Removal:

1. Park machine safely. See “Parking Safely” on page 3 of the Safety Section.
2. Remove cargo box. See “Cargo Box Removal and Installation” on page 310 in the Miscellaneous section.
3. Remove engine from machine. See “Engine Removal and Installation” on page 49.
4. Remove transaxle from machine. See “Transaxle Removal and Installation” on page 243.

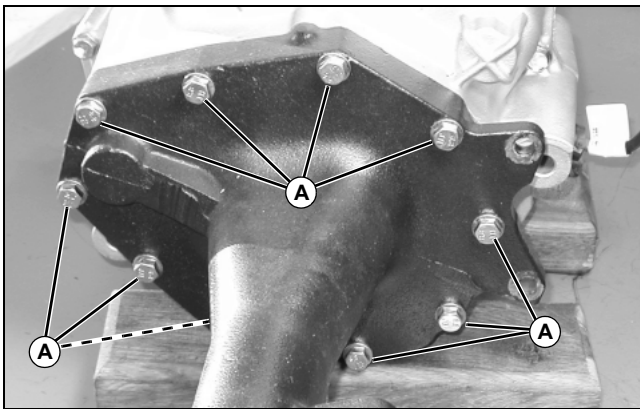

5. Remove the ten cap screws (A) securing the axle housing to the transaxle case.
6. Support the axle housing. Separate the axle housing from the transaxle case.

### Installation:

1. Clean all gasket material from mating surfaces.

2. Install ten cap screws (A) securing the axle housing to the transaxle case. Tighten to specification.
3. Install transaxle into machine. See “Transaxle Removal and Installation” on page 243.

### Specification:

Axle Housing Cap Screws . . . 23 - 30 N•m (17 - 22 lb-ft)

## Axle Housing Disassembly and Assembly

### Disassembly:

1. Remove axle housings. See “Axle Housing Removal and Installation” on page 247.

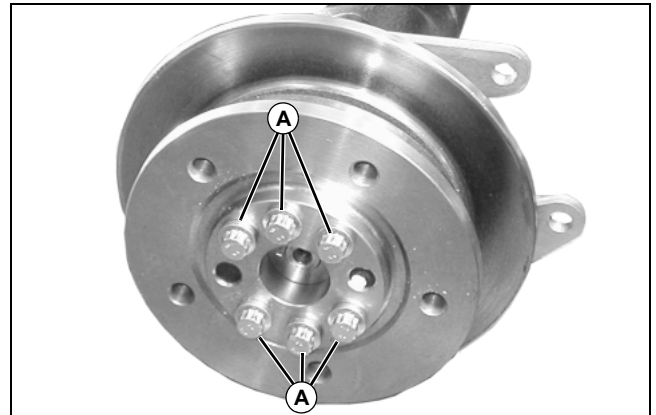

MX34167

2. Remove the six cap screws (A) securing the brake rotor to the axle shaft.

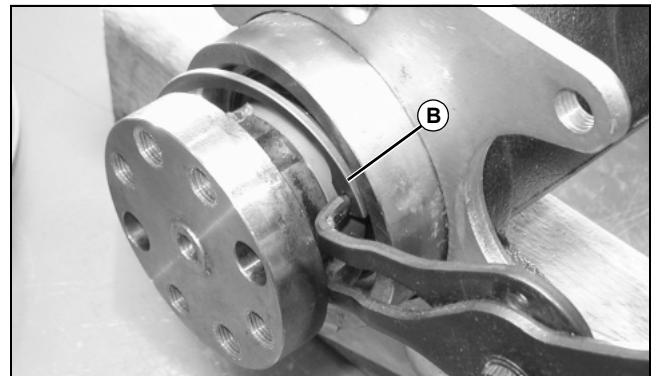

MX34168

3. Remove the internal retaining ring (B).



**Suggest:**

**If the above button click is invalid.**

**Please download this document**

**first, and then click the above link**

**to download the complete manual.**

**Thank you so much for reading**

# POWER TRAIN - GEAR REPAIR

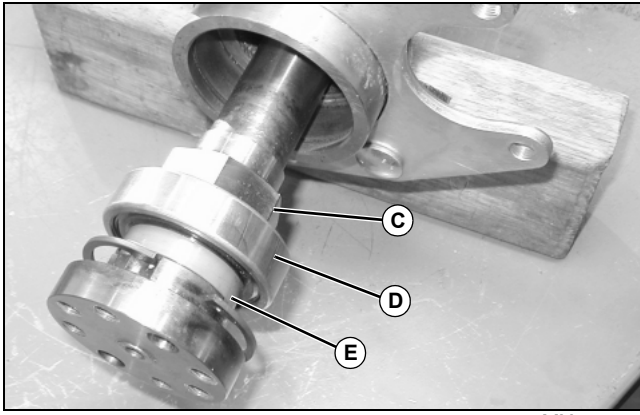

MX34170

4. Pull the axle shaft and outer bearing assembly out of the axle housing.
5. Secure the axle shaft in a vise and remove the lock nut (C), bearing (D), and collar (E).

## Assembly:

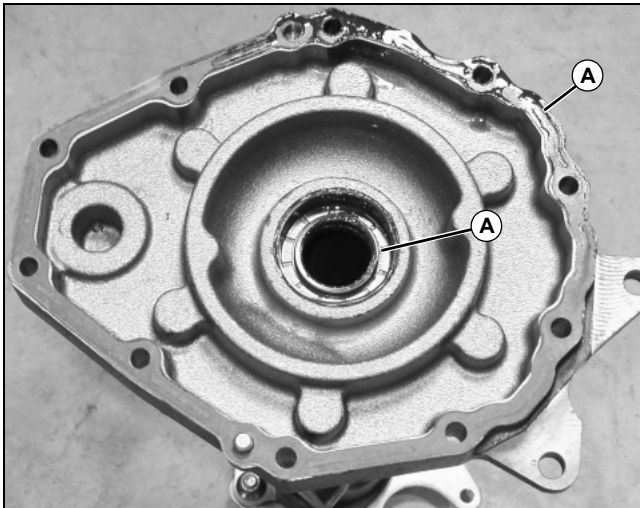

MX34169

1. Inspect the shaft seal (A) for damage. Replace as needed. Install new shaft seal until flush with case.
2. Clean all gasket material from mating surfaces.
3. Install the collar and bearing onto the axle shaft. Install the lock nut and tighten to specification.
4. Install the axle shaft and outer bearing assembly into the axle housing and secure with retaining ring.
5. Install the brake rotor and secure with six cap screws. Tighten to specification.

## Specifications:

**Axle Bearing Lock Nut . . . 118 - 167 N•m (87 - 123 lb-ft)**  
**Brake Rotor Cap Screws . . . . . 73 N•m (54 lb-ft)**

## Transaxle Disassembly and Assembly - TX

### Disassembly:

1. Remove axle housings. See "Axle Housing Removal and Installation" on page 247.

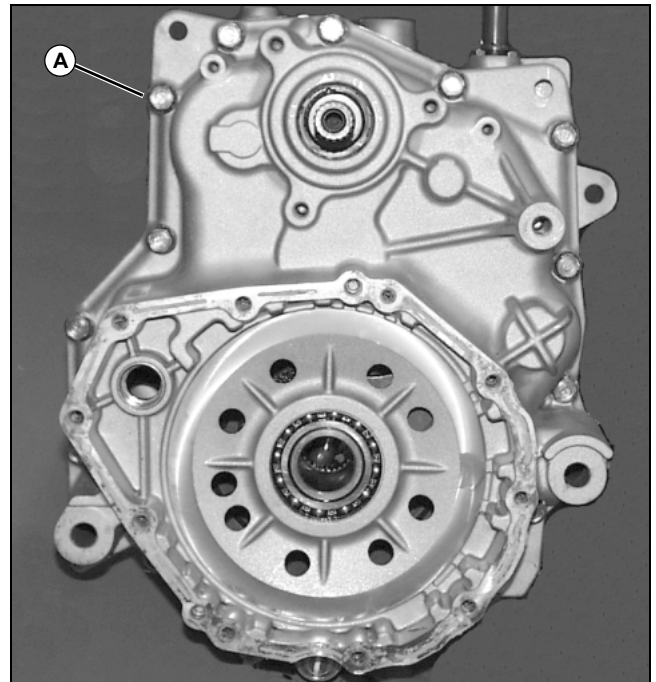

MX33398

2. Remove 15 cap screws (A) securing transaxle case halves. Carefully separate case halves.



MX33399

3. Remove input shaft assembly (B).

**<https://www.ebooklibonline.com>**

Hello dear friend!

Thank you very much for reading.

Enter the link into your browser.

The full manual is available for immediate download.

**<https://www.ebooklibonline.com>**