

TRS21/21E/22/24/26/27/32 and TRX24/26 Walk-Behind Snowthrowers/Snowblowers

TECHNICAL MANUAL

**John Deere
Lawn & Grounds Care Division
TM1466 (20Jan95)
Replaces TM1466 (25Aug92)**

Introduction

FOREWORD

This manual is written for an experienced technician. Essential tools required in performing certain service work are identified in this manual and are recommended for use.

Live with safety: Read the safety messages in the introduction of this manual and the cautions presented throughout the text of the manual.

N This is the safety-alert symbol. When you see this symbol on the machine or in this manual, be alert to the potential for personal injury.

Technical manuals are divided in two parts: repair and diagnostics. Repair sections tell how to repair the components. Diagnostic sections help you identify the majority of routine failures quickly.

Information is organized in groups for the various components requiring service instruction. At the beginning of each group are summary listings of all applicable essential tools, other materials needed to do the job and service parts kits.

Section 10, Group 15—Repair Specifications, consist of all applicable specifications, near tolerances and specific torque values for various components on each individual machine.

Binders, binder labels, and tab sets can be ordered by John Deere dealers direct from the John Deere Distribution Service Center.

This manual is part of a total product support program.

FOS MANUALS—REFERENCE

TECHNICAL MANUALS—MACHINE SERVICE

COMPONENT MANUALS—COMPONENT SERVICE

Fundamentals of Service (FOS) Manuals cover basic theory of operation, fundamentals of troubleshooting, general maintenance, and basic type of failures and their causes. FOS Manuals are for training new personnel and for reference by experienced technicians.

Technical Manuals are concise guides for specific machines. Technical manuals are on-the-job guides containing only the vital information needed for diagnosis, analysis, testing, and repair.

Component Technical Manuals are concise service guides for specific components. Component technical manuals are written as stand-alone manuals covering multiple machine applications.

Contents

SECTION 10—GENERAL INFORMATION

- Group 05—Safety
- Group 10—General Specifications
- Group 15—Repair Specifications
- Group 20—Fuels and Lubricants
- Group 25—Serial Number Locations

SECTION 20—4 AND 5-HP ENGINE REPAIR—TRS22 AND TRS/TRX24

- Group 05—Carburetor, Fuel Tank, and Muffler
- Group 10—Remove and Install Engine
- Group 15—Blower Housing, Cylinder Head, and Breather
- Group 20—Governor, Camshaft, and Tappets
- Group 25—Flywheel, Crankshaft and Piston Assembly
- Group 30—Cylinder Block
- Group 35—Recoil Starter

SECTION 21—8 AND 10-HP ENGINE REPAIR—TRS/TRX26, TRS27, TRS32

- Group 05—Carburetor, Fuel Tank, and Muffler
- Group 10—Remove and Install Engine
- Group 15—Blower Housing, Cylinder Head, and Breather
- Group 20—Governor, Camshaft, and Tappets
- Group 25—Flywheel, Crankshaft and Piston Assembly
- Group 30—Cylinder Block
- Group 35—Recoil Starter

SECTION 25—4 AND 5-HP ENGINE REPAIR—TRS21

- Group 05—Fuel System and Muffler
- Group 10—Engine
- Group 15—Recoil Starter

SECTION 40—ELECTRICAL

- Group 05—Electric Starter—4-Cycle Engines
- Group 06—Electric Starter
- Group 10—4 and 5-HP Ignition and Charging

System

- Group 15—8 and 10-HP Ignition and Charging System
- Group 20—4 HP (2-Cycle) Ignition System

SECTION 50—POWER TRAIN—TRS22, TRS/TRX24 & 26

- Group 05—Drive Belt Care and Maintenance
- Group 10—Power Train Repair
- Group 15—Blower and Auger Drive Repair

SECTION 55—POWER TRAIN—TRS27 AND 32

- Group 05—Drive Belt Care and Maintenance
- Group 10—Power Train Repair—TRS27 and 32 (S.N. —140000)
- Group 15—Blower and Auger Drive Repair
- Group 20—Power Train Repair—TRS27 and 32 (S.N. 140001—)

SECTION 85—AUGER DRIVE SYSTEM—TRS1

- Group 05—Drive Belt Care and Maintenance
- Group 10—Auger Drive Repair

SECTION 210—TEST AND ADJUSTMENT SPECIFICATIONS/OPERATIONAL CHECKOUT PROCEDURES

- Group 05—Test and Adjustment Specifications
- Group 10—Operational Checkout Procedures

SECTION 220—ENGINE—4-CYCLE ENGINES

- Group 05—Component Location
- Group 10—Theory of Operation
- Group 15—Diagnosis, Tests and Adjustments

SECTION 225—ENGINE—2-CYCLE ENGINES

- Group 05—Component Location
- Group 10—Theory of Operation
- Group 15—Diagnosis, Tests and Adjustments

Continued on next page

All information, illustrations and specifications in this manual are based on the latest information available at the time of publication. The right is reserved to make changes at any time without notice.

TM1466-20Jan95

COPYRIGHT© 1995
DEERE & COMPANY
Moline, Illinois
All rights reserved
A John Deere ILLUSTRATION™ Manual
Previous Editions
Copyright© 1989 Deere & Company

<https://www.ebooklibonline.com>

Hello dear friend!

Thank you very much for reading.

Enter the link into your browser.

The full manual is available for immediate download.

<https://www.ebooklibonline.com>

10 **SECTION 230—FUEL SYSTEM—4-CYCLE ENGINES**

- Group 05—Component Location—4-Cycle Engine
- Group 10—Theory of Operation
- Group 15—Diagnosis and Adjustments—4-Cycle Engine

20 **SECTION 235—FUEL SYSTEM—2-CYCLE ENGINE**

- Group 05—Component Location—2-Cycle Engine
- Group 10—Theory of Operation
- Group 15—Diagnosis and Tests—2-Cycle Engine

21 **SECTION 240—ELECTRICAL SYSTEM—4-CYCLE ENGINES**

- Group 05—Component Location—4-Cycle Engine
- Group 10—Theory of Operation
- Group 15—Diagnosis, Tests and Adjustments—4-Cycle Engine

25 **SECTION 245—ELECTRICAL SYSTEM—2-CYCLE ENGINES**

- Group 05—Component Location—2-Cycle Engine
- Group 10—Theory of Operation
- Group 15—Diagnosis and Adjustments—2-Cycle Engine

40 **SECTION 250—POWER TRAIN—TRS22, TRS/TRX24 AND 26**

- Group 05—Component Location—TRS22, TRS/TRX24 and 26
- Group 10—Theory of Operation
- Group 15—Diagnosis and Adjustments—TRS22, TRS/TRX24 and 26

50 **SECTION 255—POWER TRAIN—TRS27, AND 32**

- Group 05—Component Location—TRS27 and 32
- Group 10—Theory of Operation
- Group 15—Diagnosis and Adjustments—TRS27 and 32

85 **SECTION 280—AUGER DRIVE SYSTEM—2 STAGE**

- Group 05—Component Location—2 Stage
- Group 10—Theory of Operation
- Group 15—Diagnosis and Adjustments—2 Stage

210 **SECTION 285—AUGER DRIVE SYSTEM—TRS21**

- Group 05—Component Location—Single Stage
- Group 10—Theory of Operation
- Group 15—Diagnosis and Adjustments—Single Stage

Section 10 GENERAL INFORMATION

Contents

Page

Group 05—Safety 10-05-1

Group 10—General Specifications

Machine Specifications

TRS21 and 22 10-10-1

TRS/TRX24 and 26 10-10-3

TRS27 and 32 10-10-6

Group 15—Repair Specifications

Repair Specifications

TRS21/21ES 10-15-1

TRS22 and TRS/TRX24 10-15-2

TRS/TRX26 10-15-5

TRS27 and 32 10-15-7

Inch Cap Screw Torque Values 10-15-10

Set Screw Seating Torque Chart 10-15-11

Group 20—Fuels and Lubricants

Two-Cycle Gasoline Engine Oil 10-20-1

Two-Cycle Engine Fuel 10-20-1

Fuel 10-20-2

Engine Oil 10-20-2

Gear Oil 10-20-3

Grease 10-20-3

Group 25—Serial Number Locations

Serial Number Information 10-25-1

Product Identification Number Location . . 10-25-1

Engine Serial Number Location 10-25-2

Group 30—Features and Accessories . . 10-30-1

RECOGNIZE SAFETY INFORMATION

This is the safety-alert symbol. When you see this symbol on your machine or in this manual, be alert to the potential for personal injury.

Follow recommended precautions and safe operating practices.

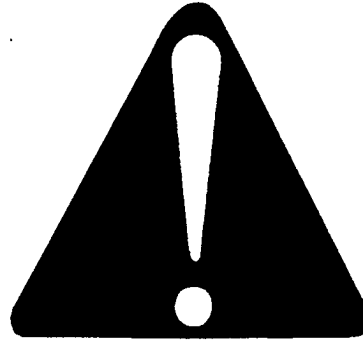

DX,ALERT -19-04JUN90

10
05
1
-UN-07DEC88
T81389

UNDERSTAND SIGNAL WORDS

A signal word—DANGER, WARNING, or CAUTION—is used with the safety-alert symbol. DANGER identifies the most serious hazards.

DANGER or WARNING safety signs are located near specific hazards. General precautions are listed on CAUTION safety signs. CAUTION also calls attention to safety messages in this manual.



DX,SIGNAL -19-09JAN92

-19-30SEP88
TS187

FOLLOW SAFETY INSTRUCTIONS

Carefully read all safety messages in this manual and on your machine safety signs. Keep safety signs in good condition. Replace missing or damaged safety signs. Be sure new equipment components and repair parts include the current safety signs. Replacement safety signs are available from your John Deere dealer.

Learn how to operate the machine and how to use controls properly. Do not let anyone operate without instruction.

Keep your machine in proper working condition. Unauthorized modifications to the machine may impair the function and/or safety and affect machine life.

If you do not understand any part of this manual and need assistance, contact your John Deere dealer.



DX,READ -19-04JUN90

-UN-23AUG88
TS201

10
05
2

HANDLE FLUIDS SAFELY—AVOID FIRES

When you work around fuel, do not smoke or work near heaters or other fire hazards.

Store flammable fluids away from fire hazards. Do not incinerate or puncture pressurized containers.

Make sure machine is clean of trash, grease, and debris.

Do not store oily rags; they can ignite and burn spontaneously.



DX,FLAME -19-04JUN90

-UN-23AUG88
TS227

PREPARE FOR EMERGENCIES

Be prepared if a fire starts.

Keep a first aid kit and fire extinguisher handy.

Keep emergency numbers for doctors, ambulance service, hospital, and fire department near your telephone.

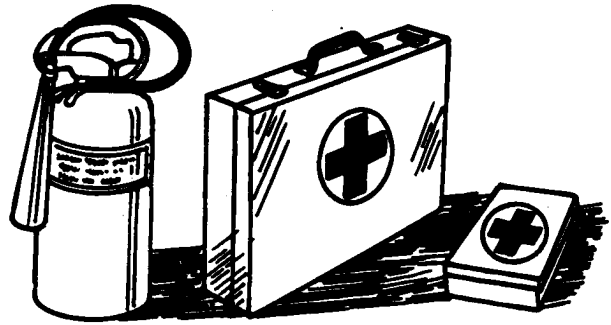

DX,FIRE2 -19-04JUN90

-UN-23AUG88
TS291

WEAR PROTECTIVE CLOTHING

Wear close fitting clothing and safety equipment appropriate to the job.

Prolonged exposure to loud noise can cause impairment or loss of hearing.

Wear a suitable hearing protective device such as earmuffs or earplugs to protect against objectionable or uncomfortable loud noises.

Operating equipment safely requires the full attention of the operator. Do not wear radio or music headphones while operating machine.

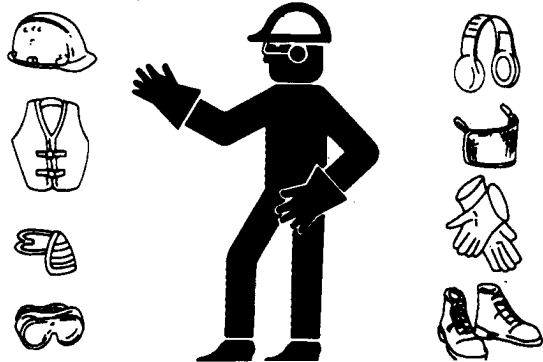

DX,WEAR -19-10SEP90

-UN-23AUG88
TS206

OTHER MATERIAL

Number	Name	Use
	SCOTCH-BRITE abrasive pads	Remove carbon deposits from combustion chamber

MX,2515FA,A1A -19-16OCT89

REMOVE AND INSTALL BLOWER HOUSING

IMPORTANT: Remove blower housing when engine is cold to prevent cylinder head warpage.

1. Loosen cap screws (A).
2. Remove cap screws (B) and (C).
3. Remove plate (D).
4. Remove blower housing.
5. Disconnect hose (E) from primer bulb.
6. Inspect blower housing.
7. Connect hose (E) to primer bulb.
8. Install blower housing.
9. Install plate (D).
10. Tighten cap screws (A) and (B) to 200 lb-in. (20.3 N·m).

A—Cylinder Head Cap Screw
B—Cylinder Head Cap Screw
C—Blower Housing Cap Screw
D—Inspection Plate
E—Primer Hose

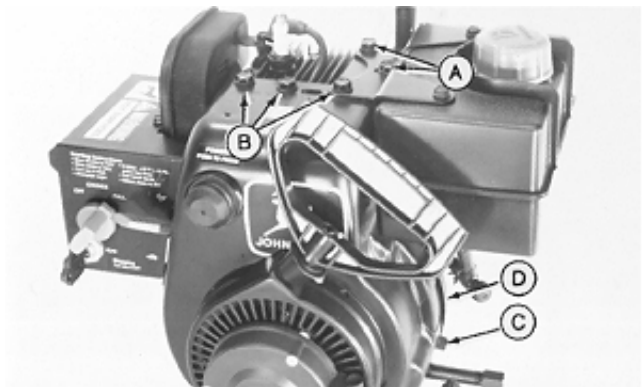

M53691 -JUN-25OCT89

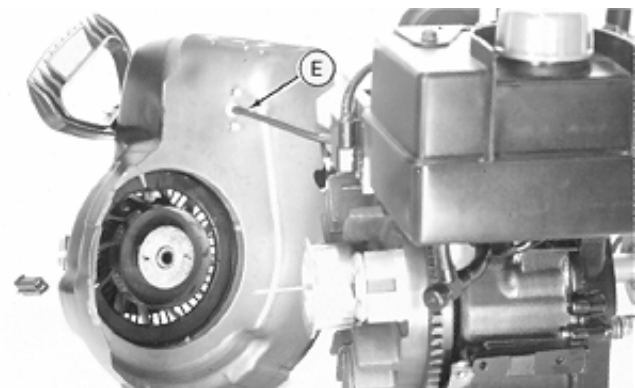

M53692 -JUN-25OCT89

MX,2515FA,A1 -19-15SEP89

REMOVE AND INSTALL CYLINDER HEAD

1. Remove blower housing. (See this group.)
2. Remove fuel tank. (See Group 05 in this section.)
3. Remove muffler. (See Group 05 in this section.)
4. Remove spark plug.

IMPORTANT: Remove cylinder head when engine is cold to prevent cylinder head warpage.

5. Remove cylinder head, gasket and fuel tank bracket.
6. Inspect cylinder head. (See this group.)
7. Install new cylinder head gasket.
8. Install cylinder head and fuel tank bracket.

NOTE: Install special cap screw (A) and short cap screws (B) in locations shown.

9. Tighten cylinder head cap screws in sequence shown to 180 lb-in. (20.3 N·m) in 50 lb-in. (5.5 N·m) increments.
10. Install muffler and fuel tank. (See Group 05 in this section.)
11. Install spark plug. Tighten to 21 lb-ft. (28 N·m).

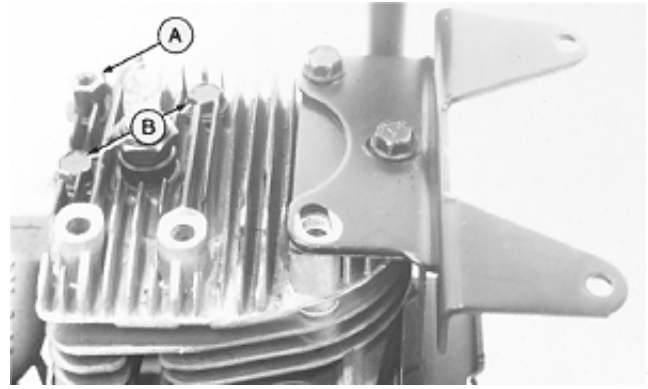

M53693 -UN-25OCT89

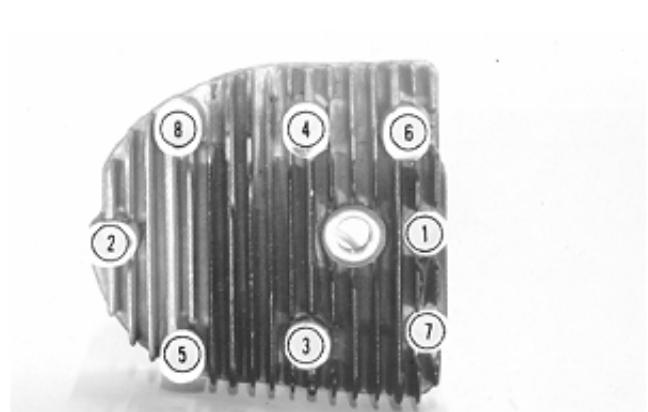

M53694 -UN-25OCT89

INSPECT CYLINDER HEAD

1. Remove carbon deposits from combustion chamber and gasket surface using SCOTCH-BRITE abrasive pads or equivalent.
2. Clean head with solvent.
3. Inspect for cracks or broken cooling fins.
4. Inspect gasket surface for burrs and nicks.
5. Check cylinder head for distortion on a surface plate. Check at several points around the head. Replace head if distortion is more than 0.002 in. (0.05 mm).

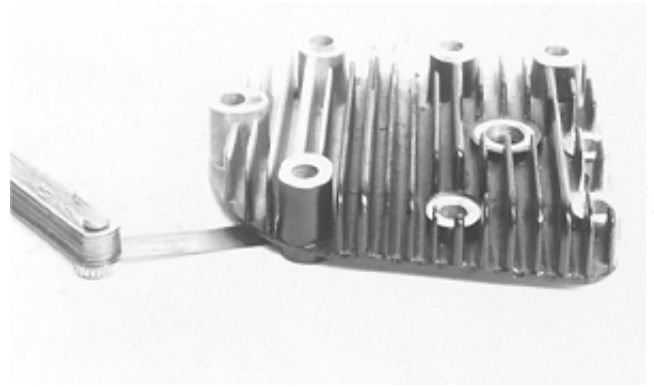

M53695 -UN-25OCT89

20
15
3

MX,2515FA,A3 -19-15SEP89

REMOVE AND INSTALL BREATHER

NOTE: Intake manifold removed for clarity.

1. Remove carburetor cover. (See Group 05 in this section.)
2. Remove cover (A) and gasket.
3. Remove element (B), bowl (C), and gasket.
4. Clean and inspect breather. (See this group.)

NOTE: Install bowl with drain hole on bottom.

5. Install gasket, bowl, and element.
6. Install gasket and cover.
7. Install carburetor cover.

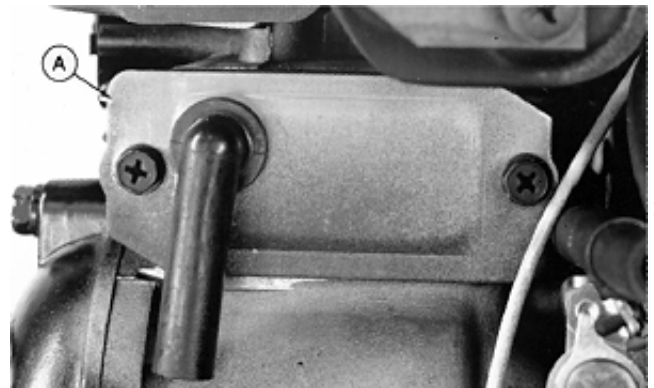

M53696 -UN-25OCT89

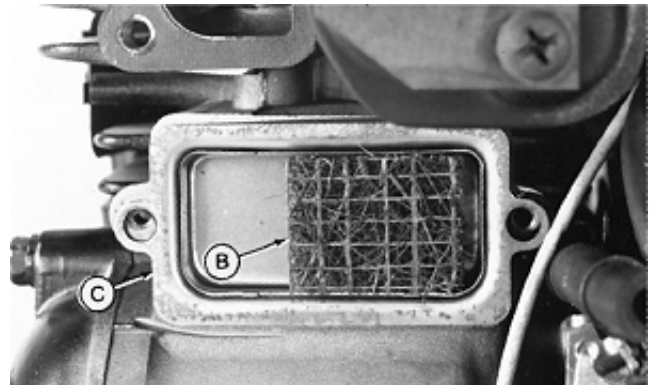

M53697 -UN-25OCT89

MX,2515FA,A4 -19-15SEP89

INSPECT BREATHER

1. Clean element (A) and bowl with solvent. Blow dry.
2. Check that drain hole (B) is open.
3. Check that reed valve (C) moves freely and closes when released.

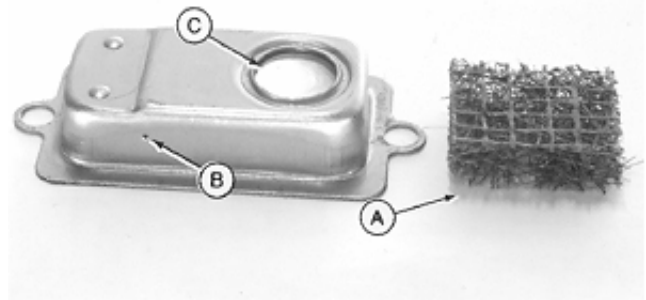

MX,2515FA,A5 -19-15SEP89

M53698 -JUN-25OCT89

REMOVE AND INSTALL VALVE ASSEMBLY

1. Remove cylinder head. (See this group.)
2. Remove intake manifold. (See this group.)
3. Remove breather assembly. (See this group.)
4. Compress valve spring and remove retainer (A).
5. Remove and inspect valve and spring. (See this group.)
6. Install spring and retainer (A).
7. Install valves.
8. Compress valve spring. Seat retainer in groove in valve stem.

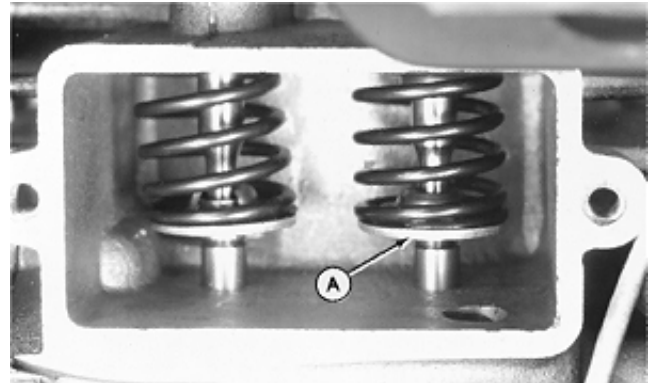

MX,2515FA,A6 -19-15SEP89

M53699 -JUN-25OCT89

INSPECT VALVE SPRINGS

1. Clean and inspect valve springs. Replace if cracked or broken.
2. Inspect valve spring (A) for squareness on a surface plate (C). Turn spring and measure space between top spring coil and square (B).
3. Measure free length of valve spring.
4. Compress valve spring. Measure compressed tension and length.

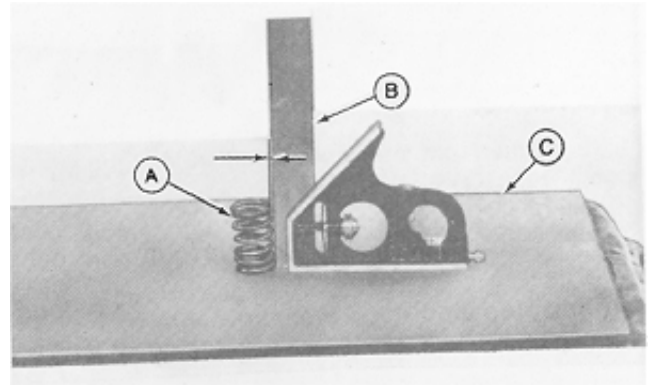

M53828 -UN-06NOV89

20
15
5

Replace valve spring if not within specifications.

VALVE SPRING SPECIFICATIONS

Squareness Tolerance	0.09 in. (2.387 mm)
Free Length	1.56 in. (36.690 mm)
Compressed Length	0.70 in. (17.856 mm)
Compressed Tension	48 lbs (21.77 kg)



M25949 -UN-06NOV89

MX,2515FA,A7 -19-18SEP89

INSPECT VALVES

1. Remove carbon from valve head, face and stem with a power-operated wire brush. Be sure carbon is removed, not merely burnished.
2. Check valve for damage. Replace warped valves (A) or valves with less than 0.0312 in. (0.792 mm) margin (B).
3. Grind valve stem ends (C) square before valve-to-tappet clearance is checked.

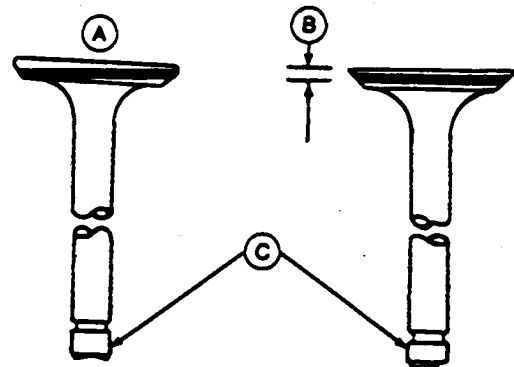

M38087 -UN-29AUG88

MX,2515FA,A8 -19-18SEP89

4. Inspect valve stem for bend using V-blocks and dial indicator. Turn valve slowly and read variation on indicator. Replace valve if variation is greater than 0.001 in. (0.03 mm).

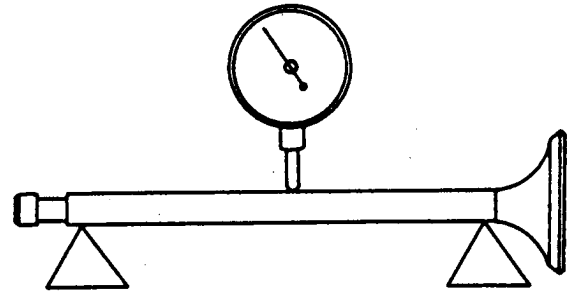

MX,2515FA,A9 -19-18SEP89

M51753 -UN-07SEP88

20
15
6

ANALYZE VALVES

Lead deposits on the intake valve are caused by exhaust gas leakage past the valve, when using leaded gasoline.

Grind intake valve and reface seat to correct this condition.

Use unleaded fuel to prevent lead deposits.



MX,2515A,A9A -19-11OCT89

M29934 -UN-06SEP88

Valve stem corrosion is caused by moisture in the engine which occurs during hot engine cool-down periods or during storage.

Fogging combustion chamber with oil before storage helps prevent corrosion.

Replace badly corroded valves.



MX,2515A,A9B -19-11OCT89

M5563 -UN-31AUG88

Blower Housing, Cylinder Head, and Breather/Valve Assembly

Operating at high temperatures for long periods of time can cause exhaust valve burning. Burned valve will show dark discoloration into the area protected by the valve guide. Another indication is distortion of the margin (A) and face (B). The valve seat may also show erosion.

An overheated engine can cause valve burning. Check for clogged engine cooling fins. Do not run engine with blower housing removed. Also check for worn valve guides, springs or tappets, lean fuel-air mixture or incorrect spark plug.

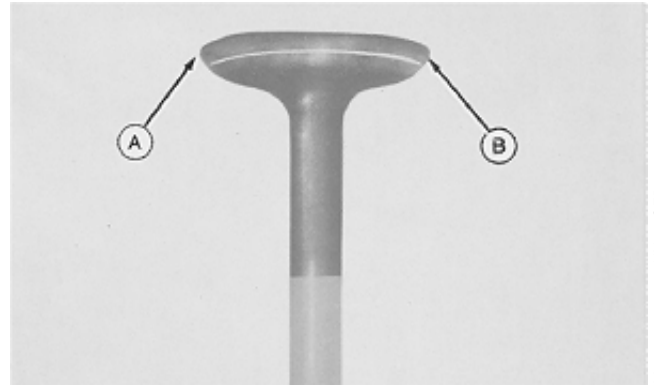

M30024 -UN-06SEP88

20
15
7

MX,2515A,A9C -19-11OCT89

Use of old or stale gasoline can cause valves to stick.

Gummy deposits (A) build up on valve and can also gum carburetor, requiring cleaning.

Always use fresh gasoline and drain fuel tank, lines and carburetor before storage.

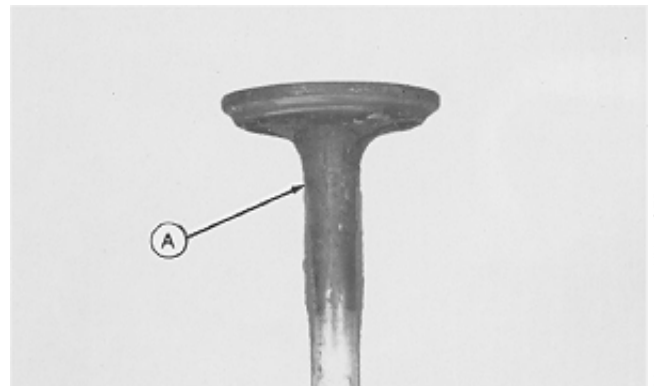

M29936 -UN-06SEP88

MX,2515A,A9D -19-11OCT89

MEASURE VALVES AND VALVE GUIDES

1. Clean inside of valve guide (A).
2. Measure inside diameter of guide with telescoping gauge. Ream guide if not within specifications.
3. Measure outside diameter of valve stem (B). Replace valve if not within specifications.

IMPORTANT: If guide is reamed oversize, an oversize valve must be installed.

4. Replace cylinder head if guide cannot be reamed to specifications.

SPECIFICATIONS

Valve Guide (STD)	0.312—0.313 in. (7.924—7.950 mm)
Valve Guide (Oversize)	0.343—0.344 in. (8.712—8.737 mm)
Valve Guide Wear Tolerance	0.0015—0.0020 in. (0.038—0.050 mm)
Intake Valve Stem Diameter (STD)	0.309—0.310 in. (7.848—7.874 mm)
Intake Valve Stem Diameter (Oversize)	0.340—0.341 in. (8.636—8.661 mm)
Exhaust Valve Stem Diameter (STD)	0.308—0.309 in. (7.823—7.848 mm)
Exhaust Valve Stem Diameter (Oversize)	0.339—0.340 in. (8.610—8.636 mm)

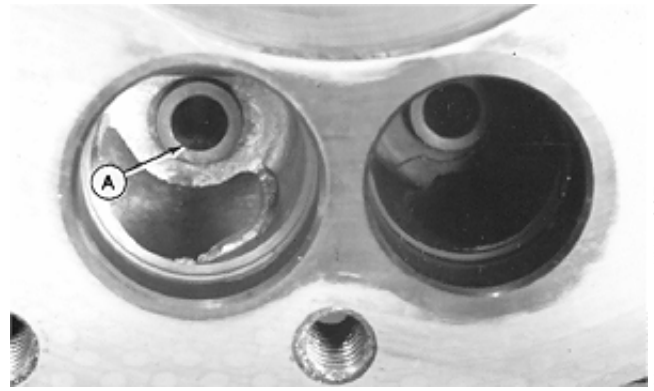

M53700 -UN-25OCT89

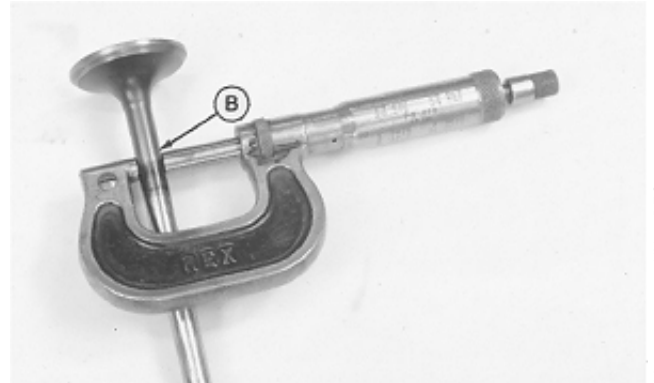

M52082 -UN-16DEC89

MX,2515FA,A10 -19-18SEP89

RECONDITION VALVE SEATS

1. Hold the valve seating surface (A) as close to 0.0469 in. (1.191 mm) as possible.

A—Valve Seating Surface 0.0469 in. (1.91 mm)	D—Valve Margin 0.0313 in. (1.587 mm)
B—Valve Seat Angle (45°)	E—Valve Narrowing Angle (30°)
C—Valve Face Angle (45°)	

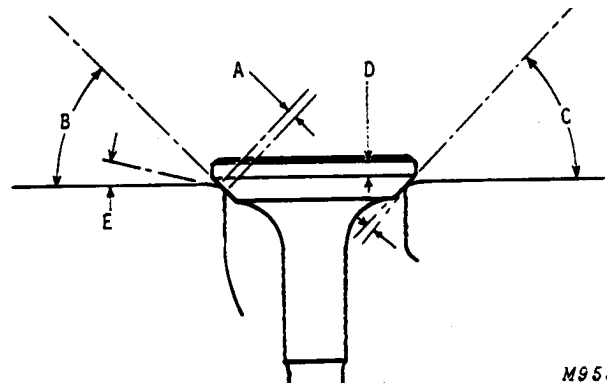

M9552

-UN-01SEP88

MX,2515FA,A9E -19-11OCT89

2. On seats with more than 0.0313 in. (0.795 mm) seating surface, cut back seating surface with a 31° cutter (A).

3. The valve seat angle (B) depends on valve face angle (C). New valves have a 45° face. Recondition valve seats with 56° cutter (A), to 0.0469 in. (1.19 mm).

4. Lap valves to seats after refacing.

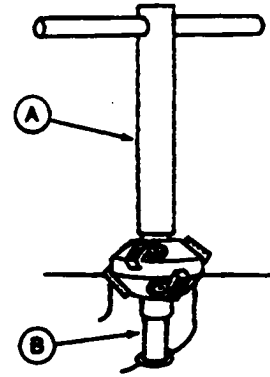

MX,2515FA,A9F -19-11OCT89

M25952 -UN-26APR89

20
15
9

5. Match valve to seat. Be sure valve seat is centered on valve face. The position of valve in seat is evident after lapping valve.

- A—Right
- B—Wrong
- C—Wrong

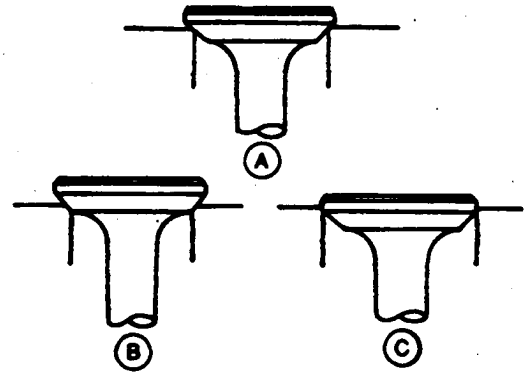

MX,2515FA,A9G -19-11OCT89

M25953 -UN-25APR89

LAP VALVES

Lap valve and seat if they do not make good contact.

1. Apply a small amount of lapping compound to valve face.
2. Turn valve in seat using vacuum cup tool.
3. Check valve every eight strokes until a uniform ring appears around surface of valve face.
4. Wash parts in solvent to remove lapping compound.
5. Check position of lap mark on face. Lap mark must be on or near center of valve face.
6. Check valve-to-tappet clearance. (See Section 220, Group 15.)

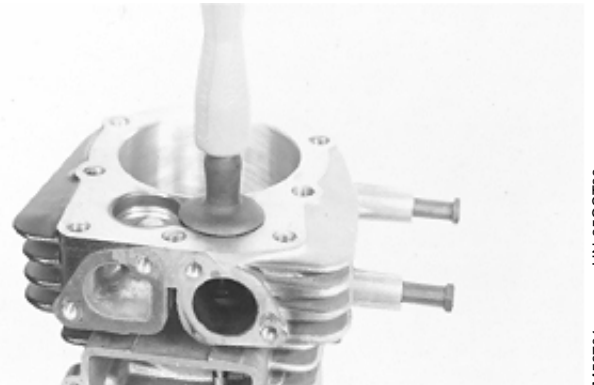

M53701 -UN-25OCT89

MX,2515FA,A11 -19-05AUG92

OTHER MATERIAL

Number	Name	Use
T43512	Thread Lock and Sealer (Medium Strength)	Apply to governor shaft.
PT569	John Deere NEVER-SEEZ® Lubricant	Apply to crankshaft end.

NEVER-SEEZ is a trademark of the Emhart Chemical Group.

MX,2620FA,A1A -19-05AUG92

20
20
1



Suggest:

If the above button click is invalid.

Please download this document

first, and then click the above link

to download the complete manual.

Thank you so much for reading

REMOVE CRANKCASE COVER—TRS/TRX24 (S.N. —120000)

1. Drain oil.

IMPORTANT: Camshaft is a tight fit in crankcase cover and can come out of crankcase with cover removal. To prevent damage to camshaft lobes or tappets, rotate camshaft so sheave key (E) is at 12 o'clock position (facing cylinder head end of engine).

2. Remove cap screw (A), lock washer, and washer.

3. Remove crankshaft sheave, spacer (B), and washers.

4. Loosen set screw (C). Remove camshaft sheave and key.

5. Remove cap screw (D). Dipstick tube can be removed from crankcase, if necessary, by turning tube counterclockwise.

IMPORTANT: Camshaft sheave set screw can cause burrs on camshaft surface. Remove burrs before removing crankcase cover, to prevent damage to seal or camshaft bearing surface.

6. Remove crankcase cover.



A—Crankshaft Sheave Cap Screw
B—Sheave Spacer
C—Camshaft Sheave Set Screw
D—Cap Screw
E—Camshaft Sheave Key

20
20
2
-JUN-25OCT89
M53702

MX,2520FA,A1 -19-05AUG92

<https://www.ebooklibonline.com>

Hello dear friend!

Thank you very much for reading.

Enter the link into your browser.

The full manual is available for immediate download.

<https://www.ebooklibonline.com>