

tm4493 - 6100 to 6600 Tractors
Cone Point Adjustment

Cone Point Adjustment

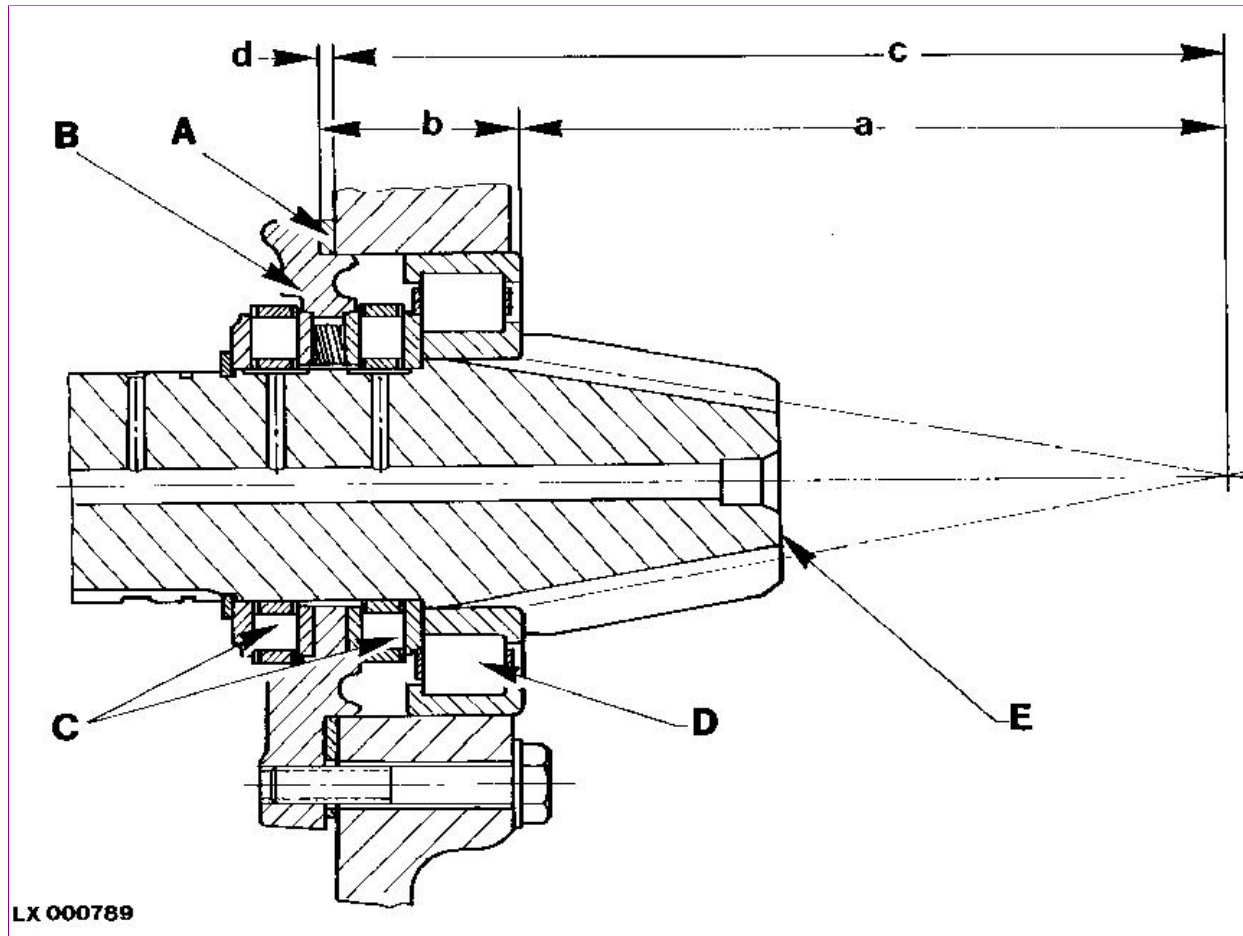

LX 000789

LX000789-UN: Cone Point Adjustment

LEGEND:

- A - Spacer washer (use as required)
- B - Bearing quill
- C - Axial bearing
- D - Needle bearing
- E - Differential drive shaft face

1. Record dimension (a) stamped into bevel gear face. In most cases this dimension is exactly 172,0 mm (6.772 in.).
2. Measure dimension (b) from needle bearing to bearing quill.
3. Cone point dimension (c) of differential housing is always 219,5 mm (8.642 in.).
4. Calculate spacer washer thickness (d).

$$d = a + b - c$$

-: Spacer Washer Thickness

Thickness of Spacer Washers Available

0,2 mm (0.008 in.) 0,5 mm (0.020 in.)
 0,3 mm (0.012 in.)

Example:

-: Calculation Example

Dimension stamped into bevel gear face.....a=172,0 mm (6.772 in.)
 Dimension from needle bearing to bearing quill, measured.....b=48,1 mm (1.894 in.)
 Cone point dimension on differential housing as specified.....c=219,5 mm (8.642 in.)

o $d = 172,0 \text{ mm} + 48,1 \text{ mm} - 219,5 \text{ mm}$

- $d = 0,6 \text{ mm}$
- $d = 6.772 \text{ in.} + 1.894 \text{ in.} - 8.642 \text{ in.}$
- $d = 0.024 \text{ in.}$

In the example two 0,3 mm (0.012 in.) spacer washers have to be used.

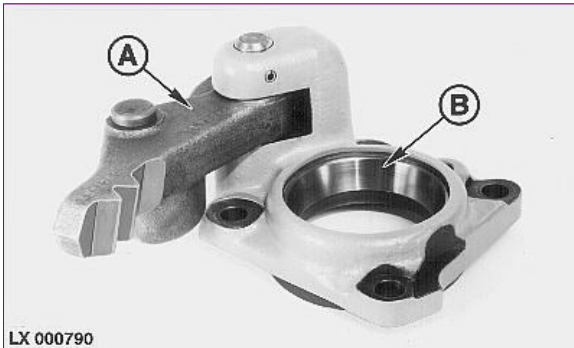

LX 000790
LX000790-UN: Locking Latch and Taper Roller Bearing Cup

Press taper roller bearing cup (B) into bearing quill.

Install locking latch (A).

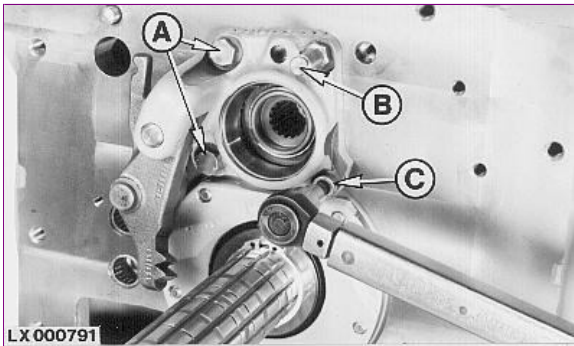

LX 000791
LX000791-UN: Tighten Screws and Bolt

Attach bearing quill.

Tighten screws (A and C) and bolt (B) to 55 N·m (40 lb-ft).

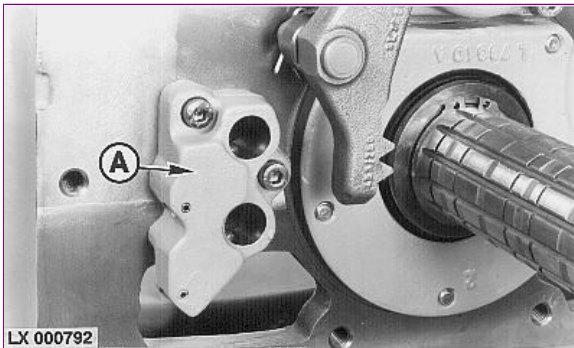

LX 000792
LX000792-UN: Install Shifter Shaft Housing

Install shifter shaft housing (A).

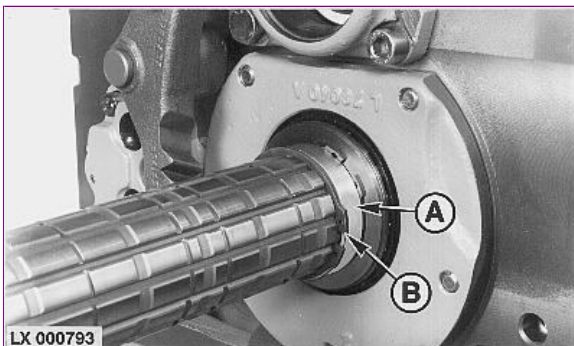

LX 000793
LX000793-UN: Install Spacer and Snap Ring

Install spacer [Older tractors only] (A).

Install snap ring (B).

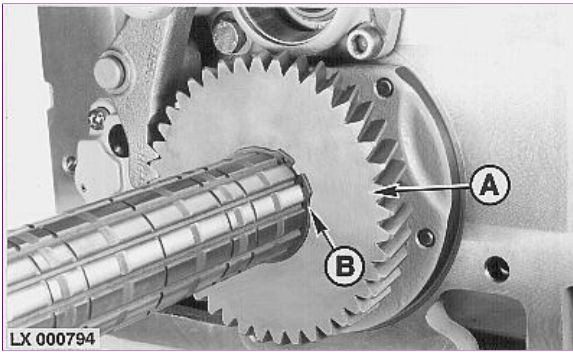

LX000794-UN: Front Wheel Drive Gear and Snap Ring

Install front wheel drive gear (A) and snap ring (B).

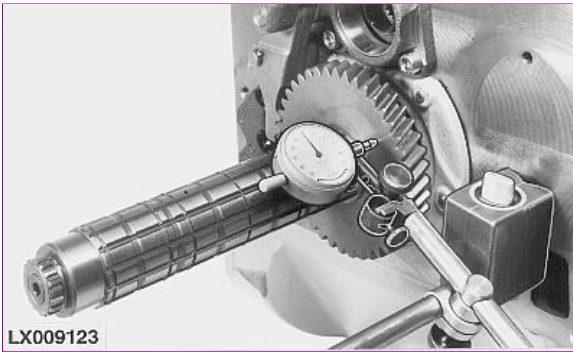

LX009123-UN: Check Axial Play

Check axial play of front wheel drive gear.

NOTE:

Front wheel drive gear axial play must be less than 0.1 mm (0.004 in.).

If axial play is not correct, use a different size snap ring to install the front wheel drive gear.

-: Snap Ring Thickness

Thickness of Snap Rings Available

2.0 mm (0.079 in.) 2.2 mm (0.087 in.)

2.1 mm (0.083 in.) 2.3 mm (0.091 in.)

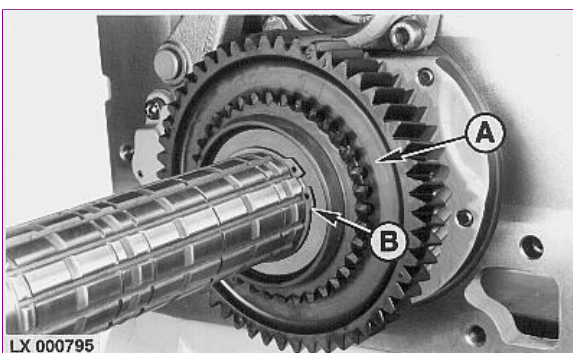

LX000795-UN: Install Thrust Washer and Snap Ring

Install thrust washer and gear of range A (A).

Install snap ring (B).

<https://www.ebooklibonline.com>

Hello dear friend!

Thank you very much for reading.

Enter the link into your browser.

The full manual is available for immediate download.

<https://www.ebooklibonline.com>

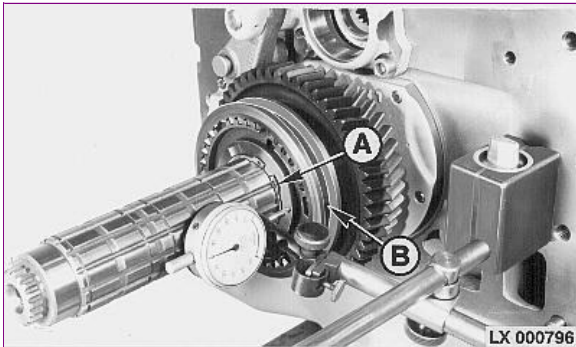

LX000796-UN: Install Synchronizer Unit and Snap Ring

Install synchronizer unit (B) and snap ring (A).

NOTE:

Axial play of synchronizer unit must be less than 0.1 mm (0.004 in.).

-: Snap Ring Thickness

Thickness of Snap Rings Available

2.0 mm (0.079 in.) 2.2 mm (0.087 in.)

2.1 mm (0.083 in.) 2.3 mm (0.091 in.)



LX000797-UN: Check Gear Axial Play

Check axial play of gear for range A.

IMPORTANT:

When measuring axial play, use both hands to guide the gear onto the shaft. Make sure the gear is straight (i.e. not skewed).

NOTE:

Axial play of gear must be 0.15 to 0.6 mm (0.006 to 0.024 in.).

If axial play is not correct, use a different size thrust washer to install gear of range A.

-: Thrust Washer Thickness

Thickness of Thrust Washers Available

3.65 mm (0.144 in.) 3.95 mm (0.156 in.)

3.80 mm (0.150 in.)

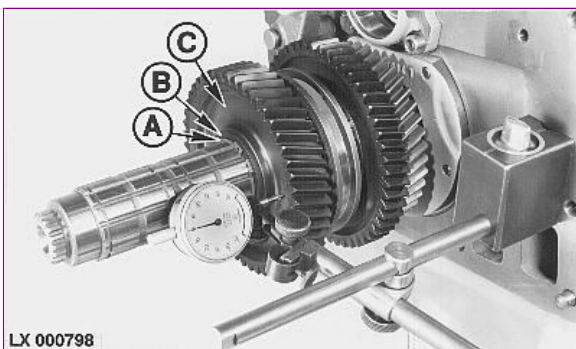

LX000798-UN: Snap Ring, Thrust Washer and Gear

Install gear of range B (C) and thrust washer (B).

Install snap ring (A).

IMPORTANT:

When measuring axial play, use both hands to guide the gear onto the shaft. Make sure the gear is straight (i.e. not skewed).

NOTE:

Axial play of gear must be 0.15 to 0.6 mm (0.006 to 0.024 in.).

-: Thrust Washer Thickness

Thickness of Thrust Washers Available

3.65 mm (0.144 in.) 3.95 mm (0.156 in.)

3.80 mm (0.150 in.)

IMPORTANT:

Up to transmission serial no. 157465, snap ring (A) had a thickness of 2.0 mm (0.079 in.). When repairing, put additional washer L112108 on the outside of the snap ring.

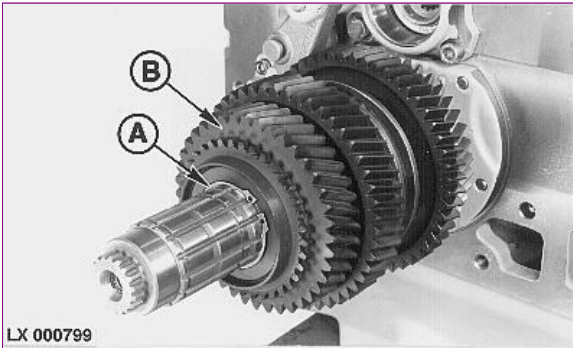

LX 000799

LX000799-UN: Install Snap Ring and Thrust Washer

Install thrust washer and gear of range C (B).

Install snap ring (A).

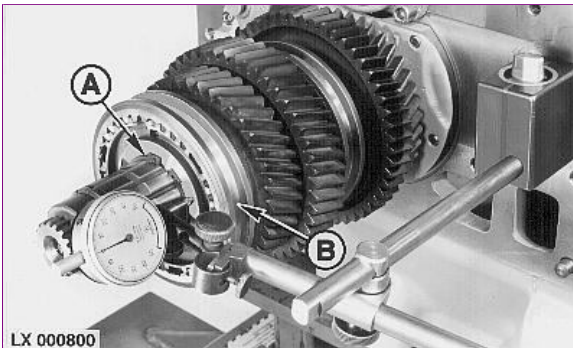

LX 000800

LX000800-UN: Install Synchronizer Unit & Snap Ring

Install synchronizer unit (B) and snap ring (A).

NOTE:

Axial play of synchronizer unit must be less than 0.1 mm (0.004 in.).

-: Snap Ring Thickness

Thickness of Snap Rings Available

2.0 mm (0.079 in.) 2.2 mm (0.087 in.)

2.1 mm (0.083 in.) 2.3 mm (0.091 in.)

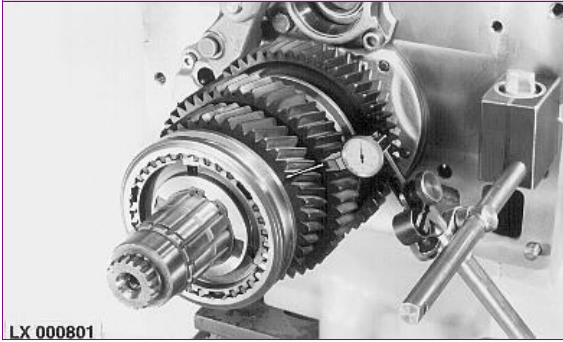

LX 000801

LX000801-UN: Check Gear Axial Play

Check axial play of gear for range C.

IMPORTANT:

When measuring axial play, use both hands to guide the gear onto the shaft. Make sure the gear is straight (i.e. not skewed).

NOTE:

Axial play of gear must be 0.15 to 0.6 mm (0.006 to 0.024 in.).

If axial play is not correct, use a different size thrust washer to install gear of range C.

-: Thrust Washer Thickness

Thickness of Thrust Washers Available

3.65 mm (0.144 in.) 3.95 mm (0.156 in.)

3.80 mm (0.150 in.)

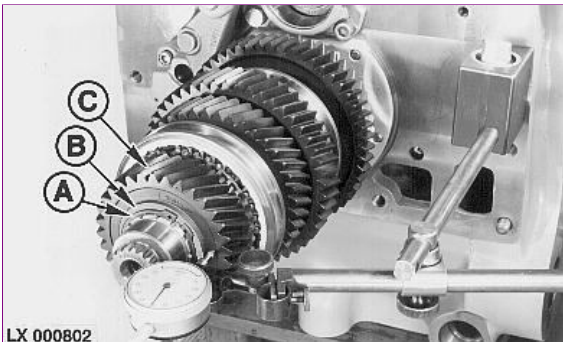

LX 000802

LX000802-UN: Install Gear, Thrust Washer & Snap Ring

Install gear of range D (C) with connecting ring.

Install thrust washer (B) and snap ring (A).

IMPORTANT:

When measuring axial play, use both hands to guide the gear onto the shaft. Make sure the gear is straight (i.e. not skewed).

NOTE:

Axial play of gear must be 0.15 to 0.6 mm (0.006 to 0.024 in.).

-: Thrust Washer Thickness

Thickness of Thrust Washers Available

3.65 mm (0.144 in.) 3.95 mm (0.156 in.)

3.80 mm (0.150 in.)

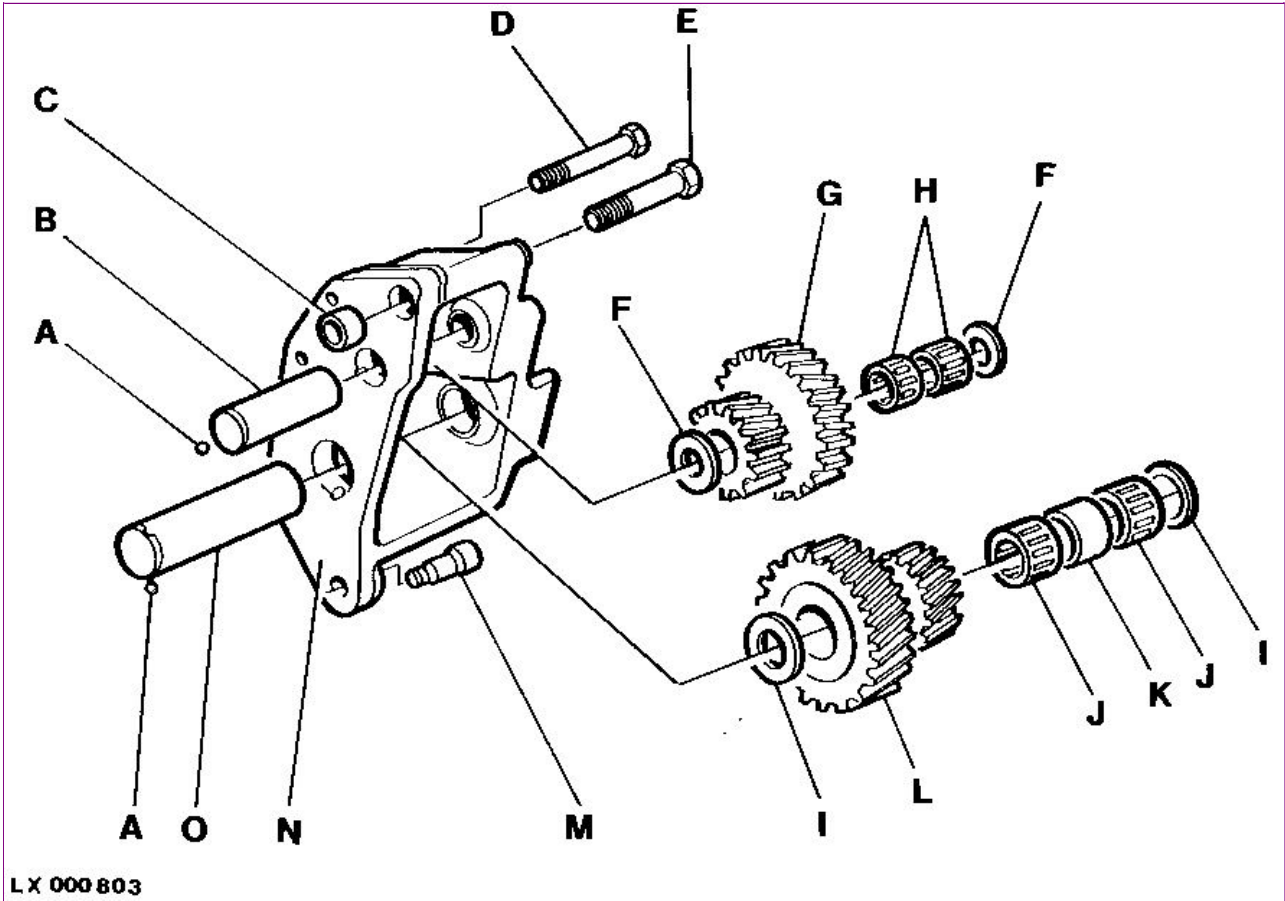

LEGEND:

- A - Ball
- B - Shaft
- C - Bushing
- D - Cap screw (2 used)
- E - Cap screw
- F - Thrust washer
- G - Double gear
- H - Needle race
- I - Thrust washer
- J - Needle race
- K - Spacer bushing
- L - Double gear
- M - Bolt
- N - Idler gear housing
- O - Shaft

Assemble idler gear housing [15- and 18-gear versions (SyncroPlus) or 20 and 24-gear versions (PowrQuad)] .

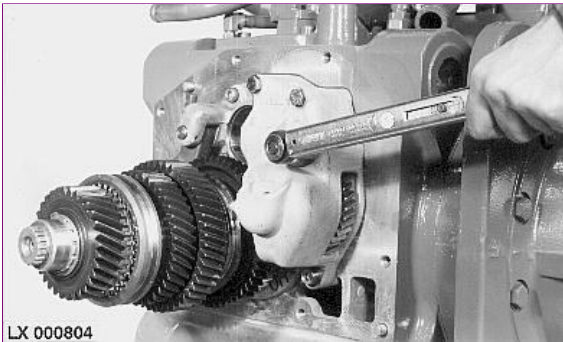

Install idler gear housing [15- and 18-gear versions (SyncroPlus) or 20 and 24-gear versions (PowrQuad)] .

Tighten cap screws to 55 N·m (40 lb-ft).

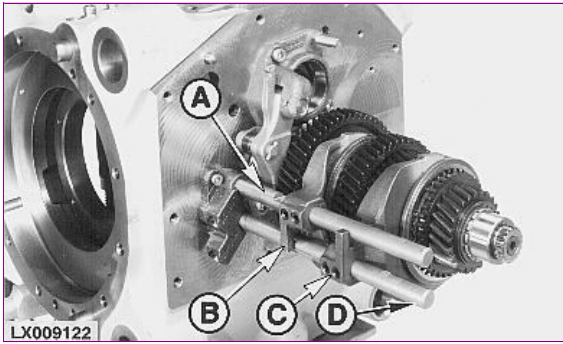

LX009122
LX009122-UN: Shifter Shafts and Shifter Forks

LEGEND:

- A - Shifter shaft (ranges A and B)
- B - Shifter fork (ranges A and B)
- C - Shifter fork (ranges C and D)
- D - Shifter shaft (ranges C and D)

Install shifter shafts and shifter forks.



LX009124
LX009124-UN: Taper Roller Bearing Cones

Press taper roller bearing cones (A) and (B) onto drive shaft.

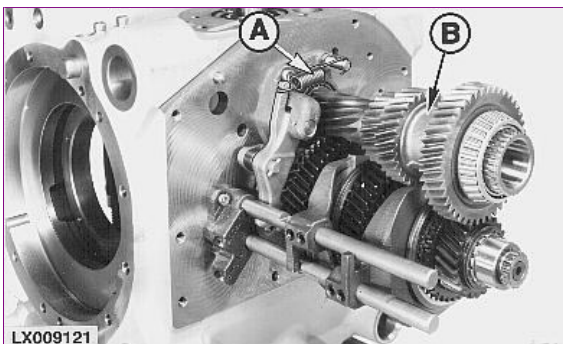

LX009121
LX009121-UN: Install Drive Shaft and Spring

Install drive shaft (B).

Connect spring (A) of parking lock.

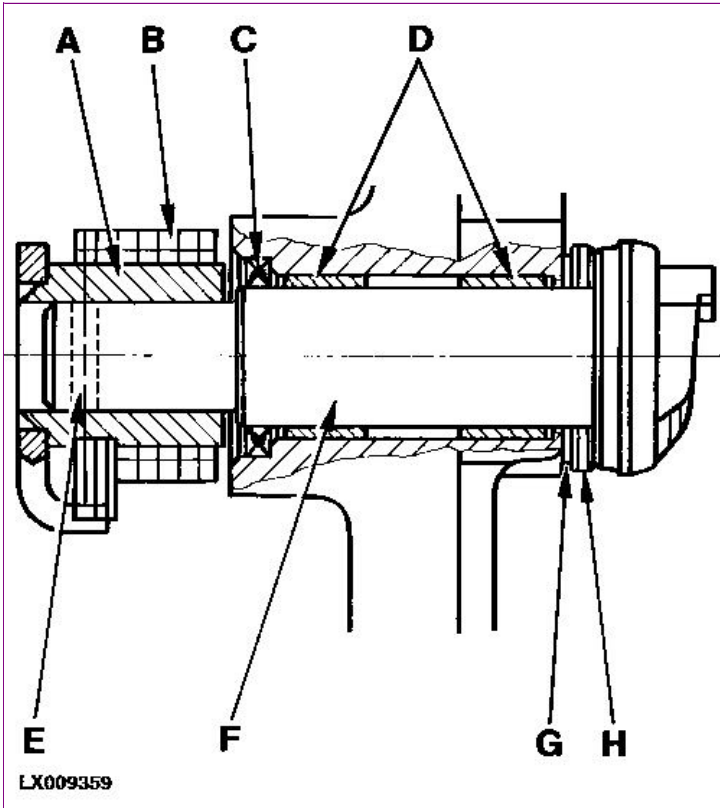

LX009359-UN: Install Parking Lock Shifter Cam

LEGEND:

- A - Lever
- B - Spring
- C - Seal ring
- D - Bushing (2 used)
- E - Spring pin
- F - Shifter cam
- G - Spacer washer (thickness as required)
- H - Axial bearing assy.

Install parking lock shifter cam in the transmission housing. Use a 1.6 mm (0.063 in.) spacer washer (G) (recommended average setting).

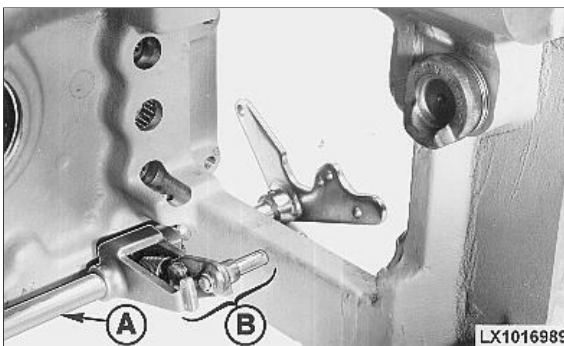

LX1016989-UN: Install Shifter Shaft & Stop Assy.

Referring to the exploded view, assemble and install the fwd/rev. shifter shaft (A) and stop assembly (B; if equipped).

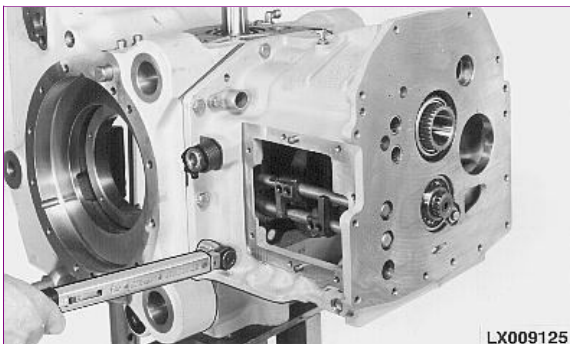

LX009125-UN: Install Transmission Housing

Install transmission housing.

Tighten cap screws.

Item	Measurement	Specification
Grade 8.8 Cap Screw	Torque	90 N·m (65 lb-ft)
Grade 10.9 Cap Screw	Torque	120 N·m (90 lb-ft)

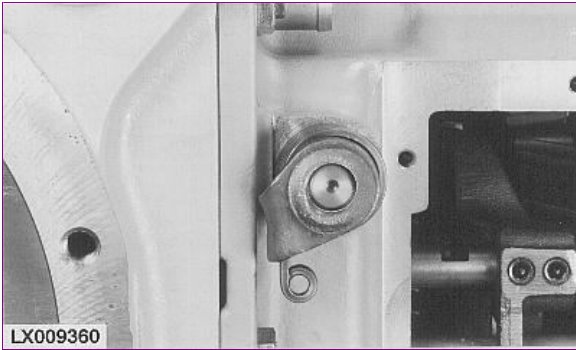

LX009360-UN: Parking lock disengaged



LX009361-UN: Parking lock engaged, play

Check play of parking lock shifter cam as follows:

1. Engage parking lock. Turn shifter cam to end point, then back 10 degrees so that the cam is no longer touching.
2. Attach dial gauge to shifter cam. Use a suitable lever or screwdriver to press the locking latch against the teeth of front wheel drive gear and measure the play of the shifter cam.
3. Play must be between 0.25 and 0.60 mm (0.010 and 0.024 in.).
4. If play is excessive, the transmission housing must be removed once more and a larger spacer washer used (see "Install parking lock shifter cam"). If play is insufficient, a smaller spacer washer must be used.

-: Space Washer Thickness

Thickness of Spacer Washer Available

- | | |
|--------------------|--------------------|
| 1.2 mm (0.047 in.) | 1.7 mm (0.067 in.) |
| 1.3 mm (0.051 in.) | 1.8 mm (0.071 in.) |
| 1.4 mm (0.055 in.) | 1.9 mm (0.075 in.) |
| 1.5 mm (0.059 in.) | 2.0 mm (0.079 in.) |
| 1.6 mm (0.063 in.) | |

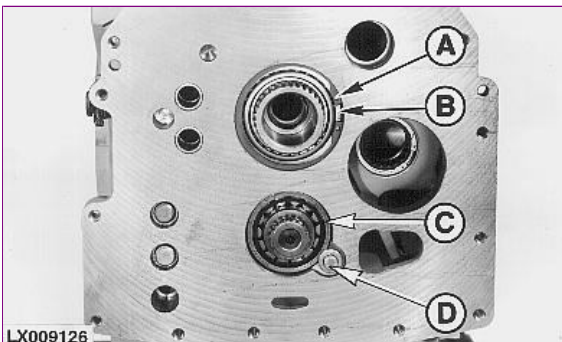

LX009126-UN: Install Taper Roller Bearing Cup

LEGEND:

- A - Snap ring (thickness as required)
- B - Taper roller bearing cup

- C - Needle bearing
- D - Cap screw [Later tractor series have 2 cap screws]

Install taper roller bearing cup (B) of drive shaft and needle bearing (C) of differential drive shaft.

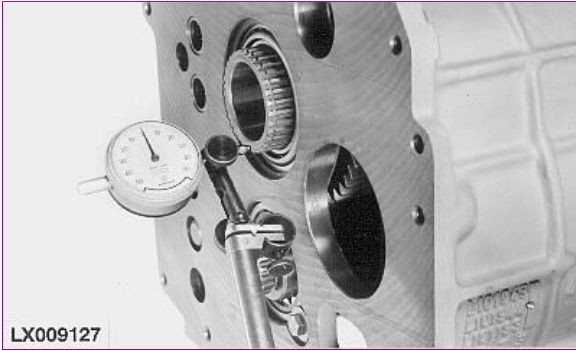

LX009127

LX009127-UN: Check Drive Shaft Axial Play

Check axial play of drive shaft.

NOTE:

Axial play of drive shaft must be less than 0.1 mm (0.004 in.).

If axial play is not correct, use a different size snap ring to install the taper roller bearing cup.

-: Snap Ring Thickness

Thickness of Snap Rings Available

2.0 mm (0.079 in.) 2.2 mm (0.087 in.)

2.1 mm (0.083 in.) 2.3 mm (0.091 in.)

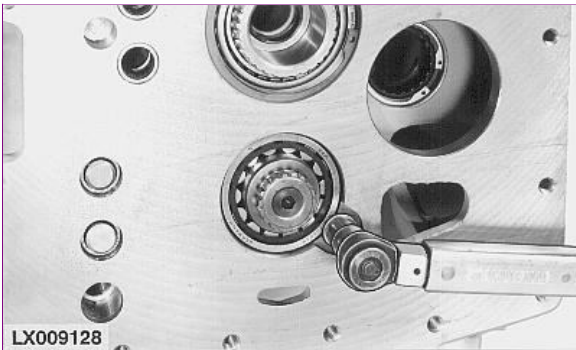

LX009128

LX009128-UN: Tighten Cap Screw

Tighten cap screw to 30 N·m (22 lb-ft).

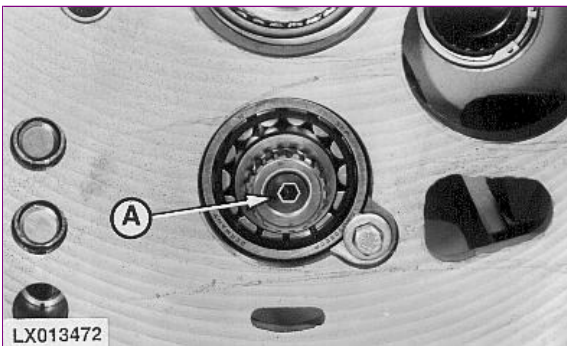

LX013472

LX013472-UN: Countersunk Screw

Coat the thread on countersunk screw [12-gear version (SyncroPlus) and 16-gear version (Power Reverser or PowrQuad) only] (A) with LOCTITE® E 648 (L41860) and tighten it to 25 N·m (18 lb-ft).

tm4493 - 6100 to 6600 Tractors Adjusting Shift Mechanism

Adjusting Shift Mechanism

1. Place shifter shafts in neutral position.

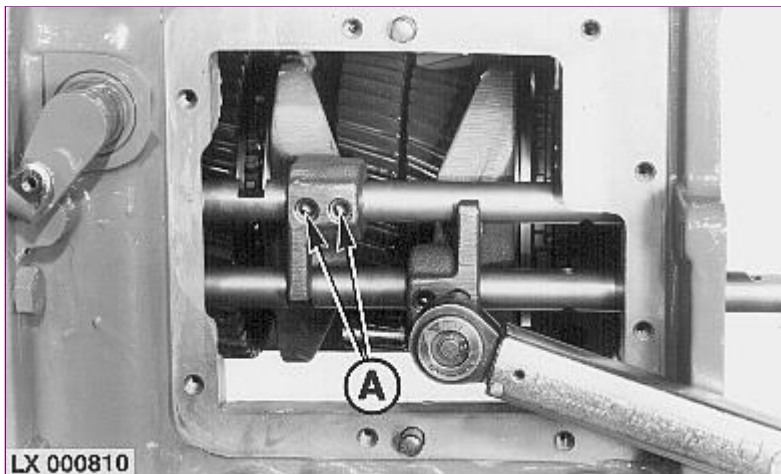

2. LX 000810
LX000810-UN: Threaded Pins

Adjust shifter forks by means of threaded pins (A) until they are centered in relation to shift collars.

3. Move shifter forks to all positions.

NOTE:

Make sure that shifter forks do not rub laterally on shift collars in any shift position.

4. Tighten threaded pins to 40 N·m (30 lb-ft).
5. Recheck adjustment.

tm4493 - 6100 to 6600 Tractors

Final Assembly

Final Assembly

1. Install front wheel drive clutch, see Section 56, Group 10.
 2. If equipped, install option transmission or creeper transmission, see Group 00.
 3. SyncroPlus™ : Install PERMA-CLUTCH 2™ and gear transmission. See Group 00.

PowrQuad™ : Install PowrQuad™ module. See Group 00.

Install forward/reverse linkage. See Section 55, Group 05.
 4. Install differential, see Section 56, Group 15.
 5. Install final drives, see Section 56, Group 00.
-

6. Install PTO, see Section 56, Group 00.

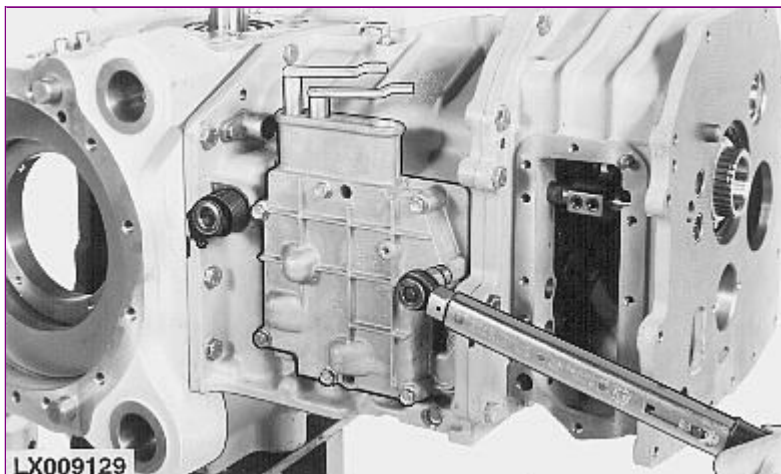

LX009129-UN: Tighten Cap Screws

Install shift cover.

Tighten cap screws to 30 N·m (22 lb-ft).

tm4493 - 6100 to 6600 Tractors Special or Essential Tools

Special or Essential Tools

NOTE:

Order tools according to information given in the U.S. SERVICEGARD™ Catalog or in the European Microfiche Tool Catalog (MTC).

Tilting device.....KJD10178
Tilting the cab up and down

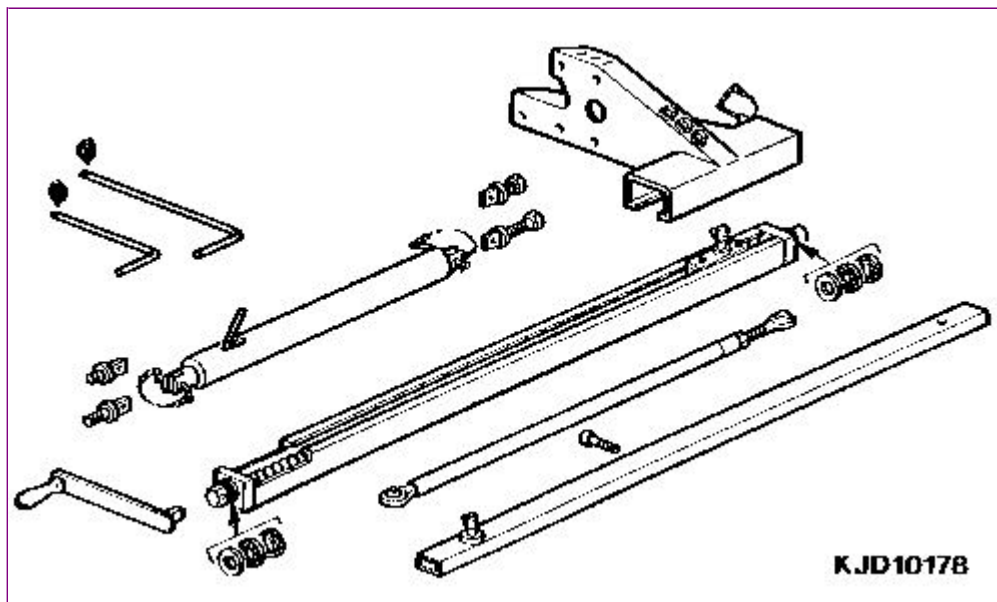

KJD10178-UN: KJD10178

Universal support stand
[Additionally required:
1 commercial 12 ton jack]JT05725
Supporting tractor during rear wheel removal.

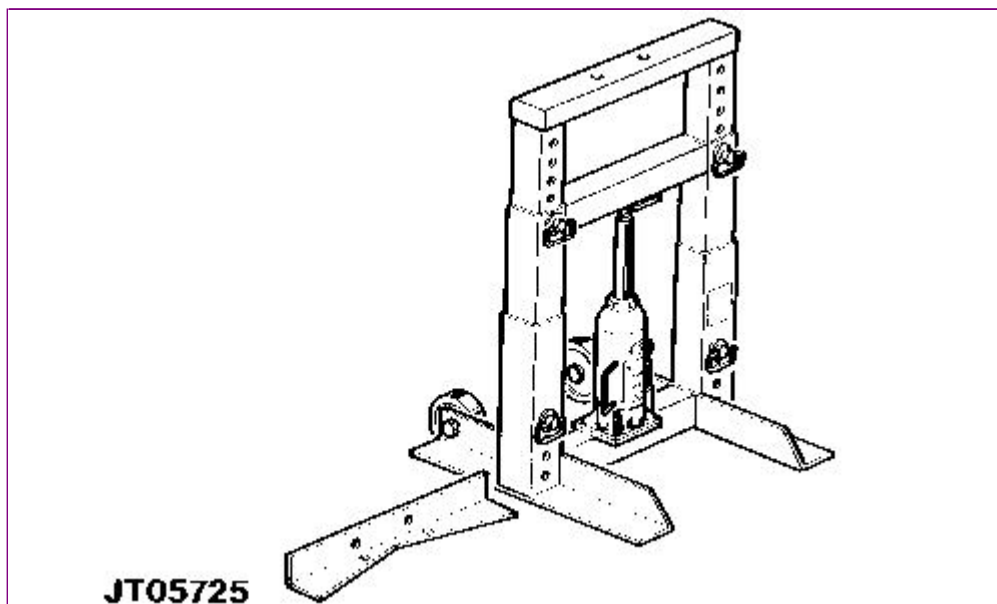

JT05725-UN: JT05725

Puller.....KJD10173
Removal and installation

of PTO drive shaft and
pump drive shaft

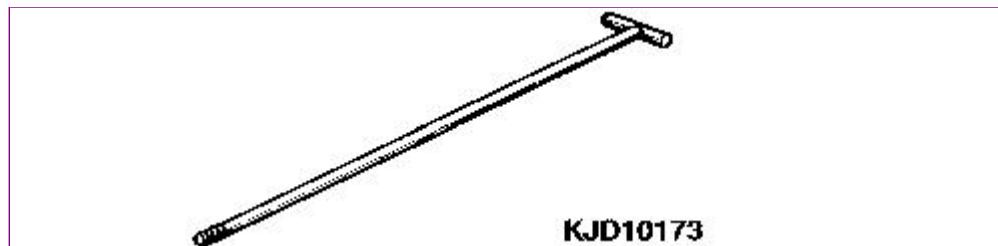

KJD10173-UN: KJD10173

Lifting eye.....JD-244-1
Removal and installation
of tractor components

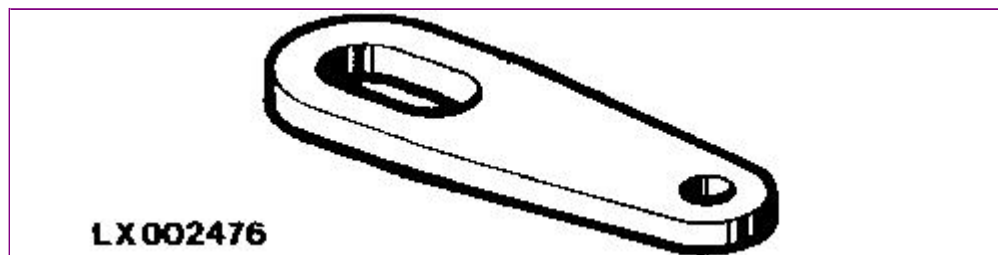

LX002476-UN: JD-244-1

Lifting eye.....JD-244-2
Removal and installation
of tractor components

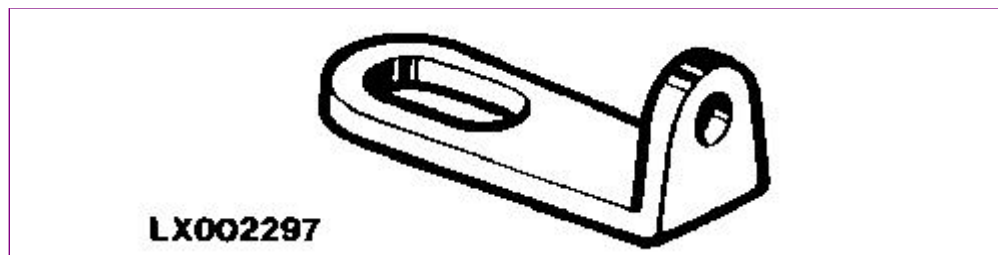

LX002297-UN: JD-244-2

Dealer-Manufactured Special Tools

See also Section 99, Group 05.

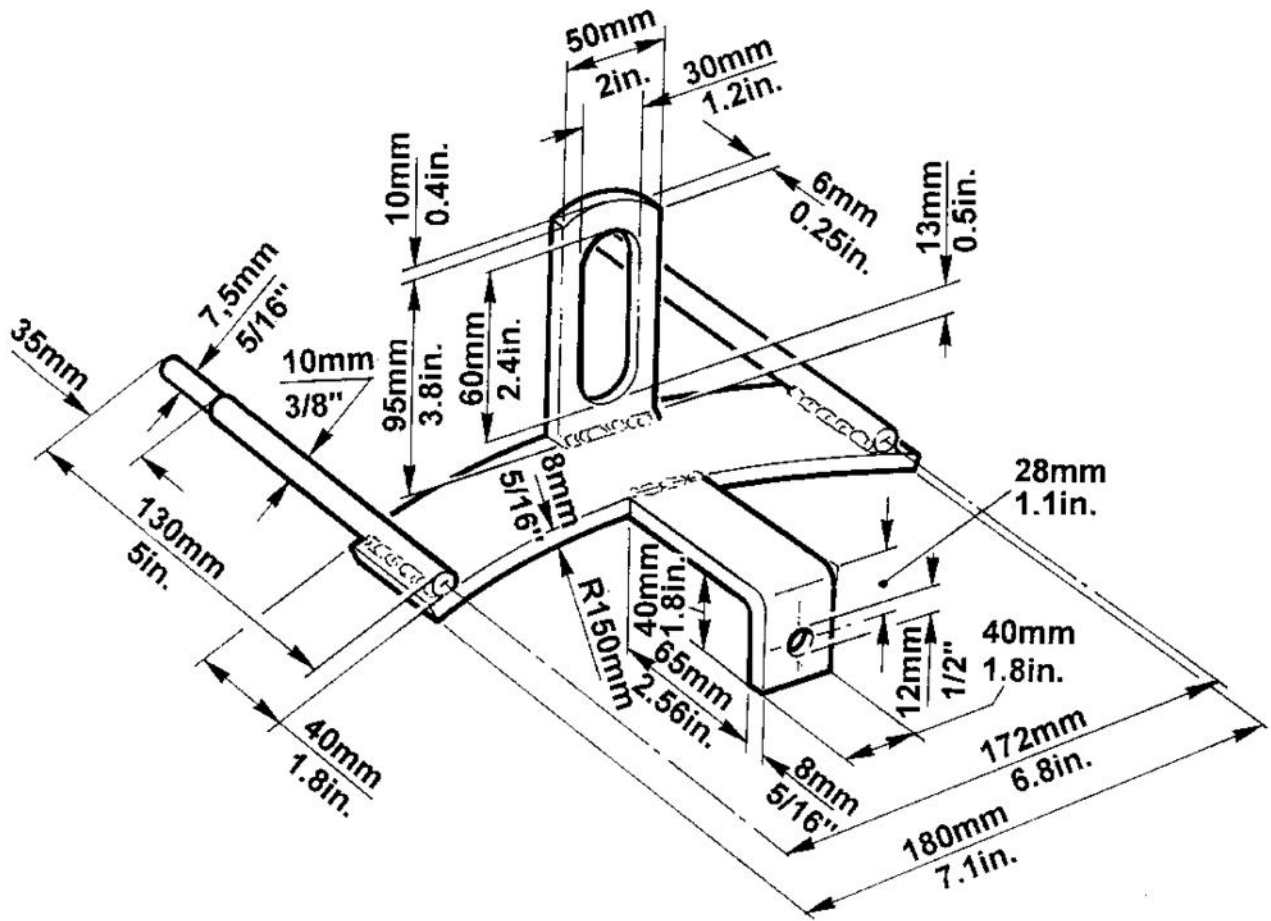

LX1016738

LX1016738-UN: Lifting Device

Lifting device for clutch housing and PowrReverser™ module.

tm4493 - 6100 to 6600 Tractors

Specifications

Specifications

Item	Measurement	Specification
U.j. shaft to drive flange, corrugated-head screws	Torque	135 N·m (100 lb-ft)
PowrReverser™ module to gear transmission, cap screws	Torque	50 N·m (35 lb-ft)
Clutch bowden cable support to clutch housing, cap screws	Torque	11 N·m (8 lb-ft)
Suction line of transmission oil pump to clutch housing, hex. socket screws	Torque	18 N·m (13.3 lb-ft)
Rear wheel to rear axle		
Tractors with flanged axle, cap screws	Torque	500 N·m (370 lb-ft)
Transmission oil, 6100 - 6400 Tractors	Capacity	52 L (13.7 U.S.gal.) approx. See Section 10, Group 05.

tm4493 - 6100 to 6600 Tractors
Removing the PowrReverser™ Module

Removing the PowrReverser™ Module

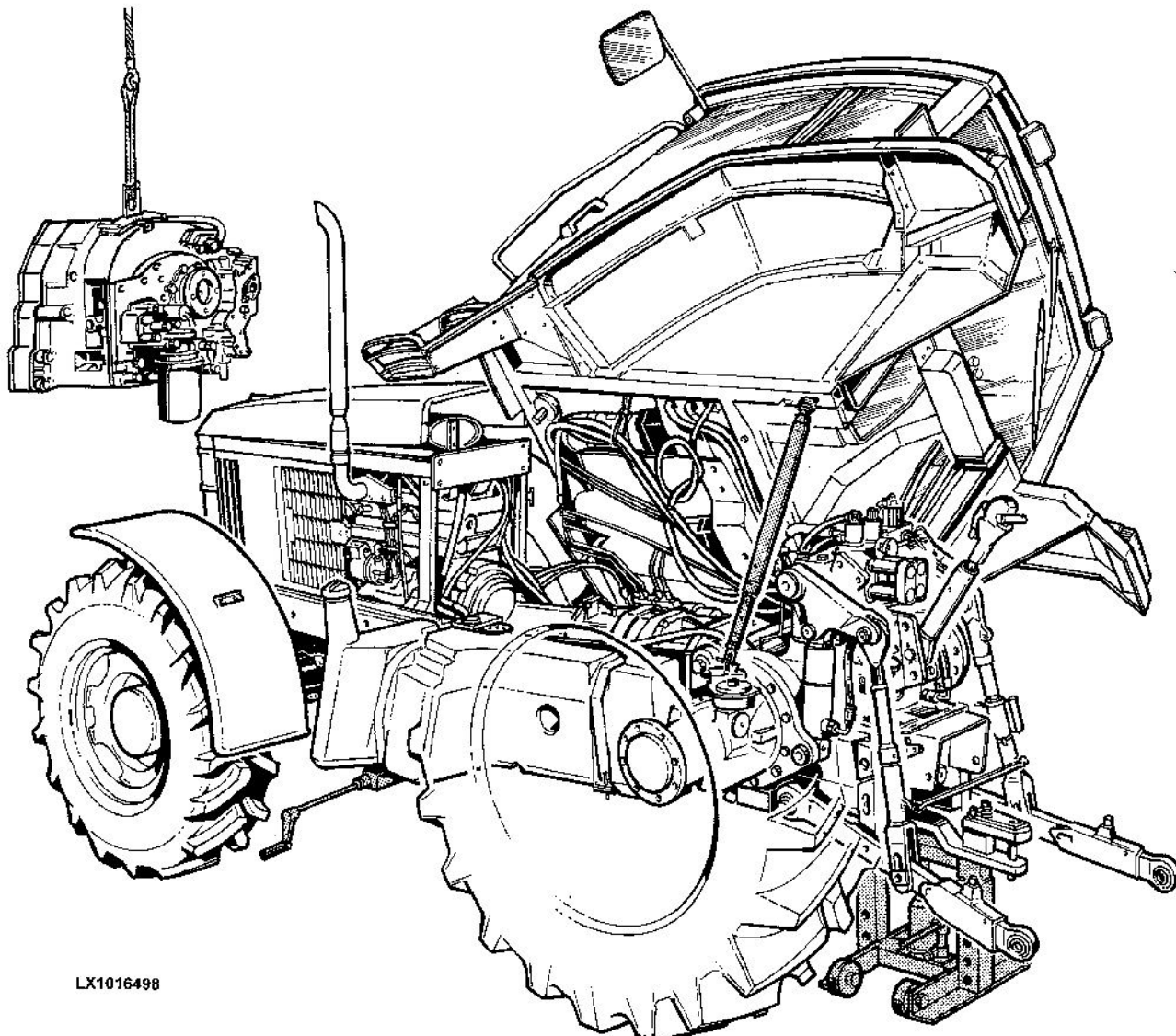

LX1016498

LX1016498-UN: PowrReverser Module



LX002206

LX002206-UN: Tilt Operator's Cab

For tilting the operator's cab, see Section 90, Groups 00 and 01.

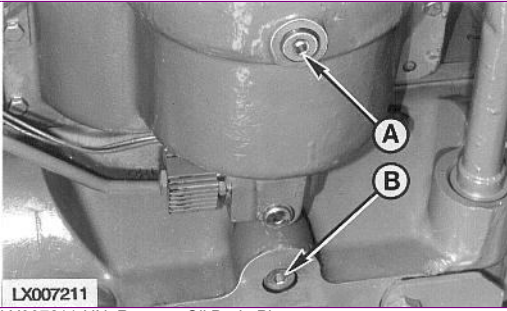

LX007211-UN: Remove Oil Drain Plugs

Pull out swinging drawbar to the rear.

Remove oil drain plugs (A) and (B). Drain transmission oil into a suitable container.

Capacity: oil and filter change approx. 52 L (13.7 U.S. gal.)

Refer to Section 10, Group 05 for the precise oil capacity.

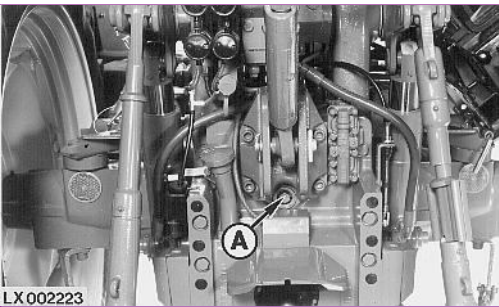

LX002223-UN: Remove Plug

Remove plug (A).

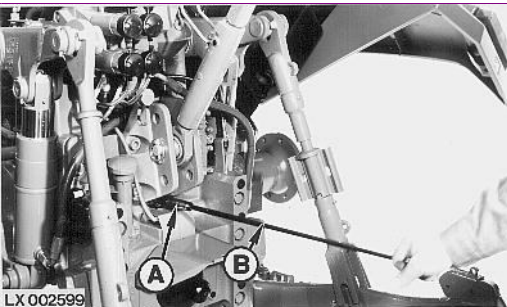

LX002599-UN: PTO Drive Shaft and Puller

Pull PTO drive shaft (A) and then pump drive shaft out of housing by means of puller KJD10173 (B).



LX1016495-UN: Remove Bracket

Remove bracket (A).

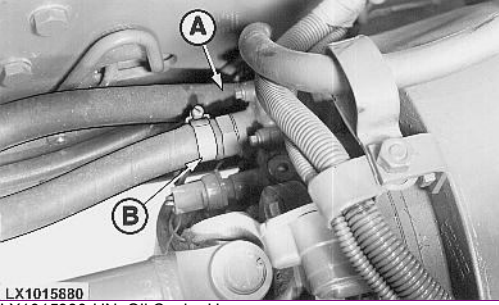

LX1015880
LX1015880-UN: Oil Cooler Hoses

Disconnect oil cooler hoses (A) and (B) where they meet the Power Reverser module.

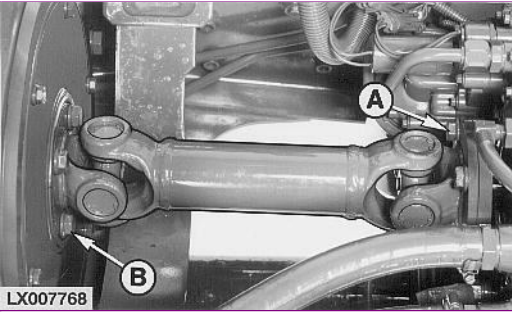

LX007768
LX007768-UN: Remove Cap Screws

Take out cap screws (A) and (B), and remove the u.j. shaft.

See also Section 56, Group 05.

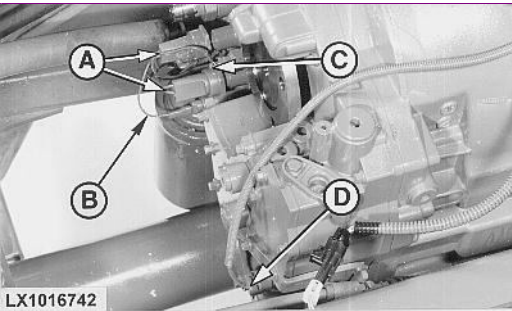

LX1016742
LX1016742-UN: Disconnect Cables and Plugs

Disconnect cables and plugs (A) to (D).

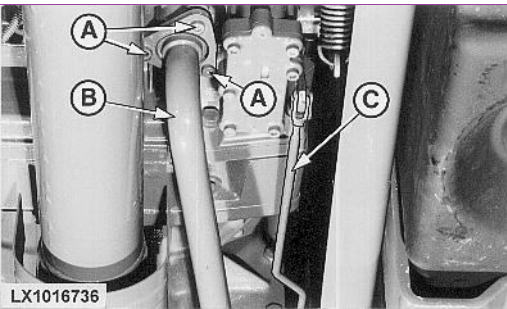

LX1016736
LX1016736-UN: Remove Screws, Suction Line and Linkage

Take out screws (A) and pull suction line (B) out of the differential housing.

NOTE:

Trap the oil as it emerges from the suction line.

Disengage forward/reverse linkage (C).

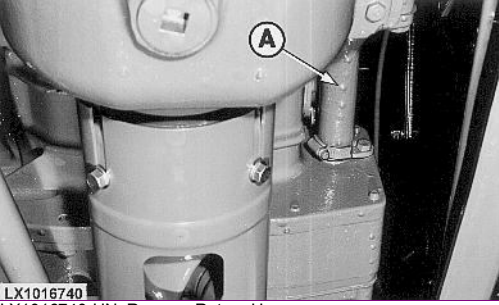

LX1016740
LX1016740-UN: Remove Return Hose

Remove return hose (A).

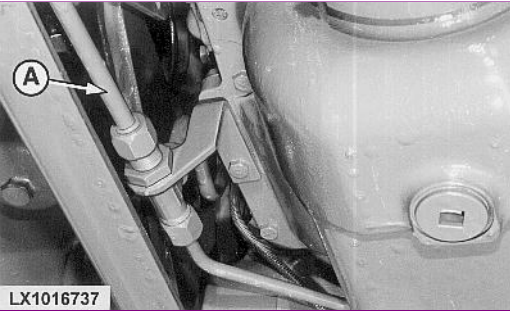

LX1016737
LX1016737-UN: Remove Pressure Line

Remove pressure line (A).

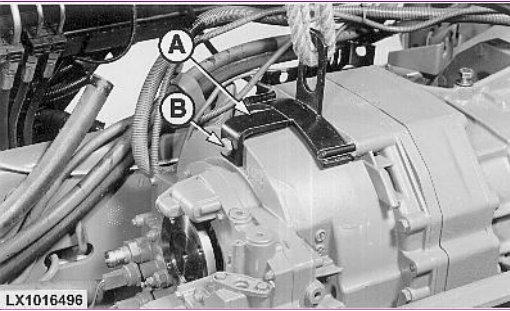

LX1016496
LX1016496-UN: Install Lifting Device and Cap Screw

Install lifting device (A) as shown, and secure it with cap screw (B). Attach lifting tackle.

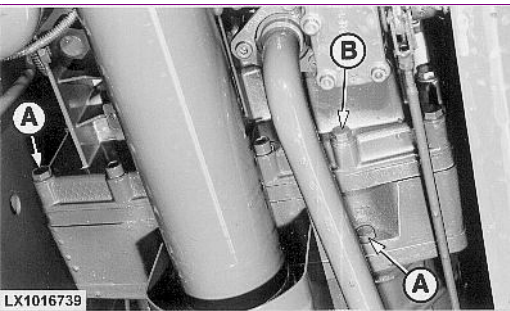

LX1016739
LX1016739-UN: Remove Screws from Housing Flange

Take screws (A) out of the housing flange and remove the PowrReverser™ module.

NOTE:

Screw (B) remains in place.

tm4493 - 6100 to 6600 Tractors Installing the PowrReverser™ Module

Installing the PowrReverser™ Module

Clean the sealing surfaces thoroughly and install a new flange seal.

Attach the lifting device and tackle to the PowrReverser™ module.

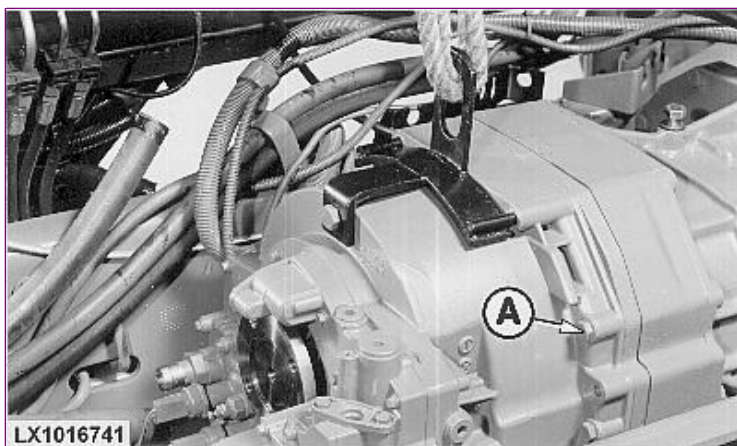

LX1016741-UN: Install Cap Screws

Install the PowrReverser™ module. Install cap screws (A) and tighten them to 50 N·m (35 lb-ft).

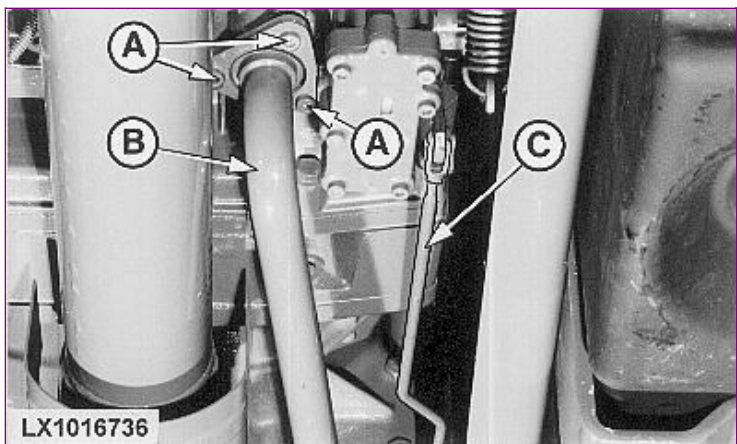

LX1016736-UN: Suction Line, Screws and Linkage

Put new seals on the suction line (B), and install the suction line on the PowrReverser™ module and differential housing.

Tighten screws (A) to 18 N·m (13.3 lb-ft).

Adjust and install forward/reverse linkage (C). See Group 05 in this Section.

For installation of u.j. shaft, refer to Section 56, Group 05.

For further assembly, reverse disassembly procedure.

Install oil drain plugs, fill with transmission oil, and check the oil level.

Tilt down the operator's cab. See Section 90.

Check all the functions of the tractor. If necessary, rectify any faults as described in the Technical Manual.



Suggest:

If the above button click is invalid.

Please download this document

first, and then click the above link

to download the complete manual.

Thank you so much for reading

tm4493 - 6100 to 6600 Tractors

Removing and Installing the Gear Transmission

Removing and Installing the Gear Transmission

NOTE:

To remove or install the gear transmission, see Section 50, Group 00 (SyncroPlus™ transmission).

NOTE:

See Group 15 in this Section for measuring the gaps at the connecting ring.

<https://www.ebooklibonline.com>

Hello dear friend!

Thank you very much for reading.

Enter the link into your browser.

The full manual is available for immediate download.

<https://www.ebooklibonline.com>