

# **Horicon Hydraulic Attachments:**

**7, 8, 8A, 10, & 10A Backhoes  
40, 44, 51, 52, 60, 67, 70, & 70A Loaders  
365, 375, 380, 380A, & 390 Front Blades  
30-Inch Hydraulic Tiller  
Hydraulic Dump MCS**

# **TECHNICAL MANUAL**

**John Deere  
Lawn & Grounds Care Division**

**TM1593 (May 95)  
Replaces TM1429**

This technical manual is written for an experienced technician and contains sections that are specifically for this product. It is a part of a total product support program.

The manual is organized so that all the information on a particular system is kept together. The order of grouping is as follows:

- Table of Contents
- Specifications
- Component Location
- System Schematic
- Theory of Operation
- Troubleshooting Chart
- Diagnostics
- Tests & Adjustments
- Repair







*Note: Depending on the particular section or system being covered, not all of the above groups may be used.*

Each section will be identified with a symbol rather than a number. The groups and pages within a section will be consecutively numbered.

All information, illustrations and specifications in this manual are based on the latest information available at the time of publication. The right is reserved to make changes at any time without notice.

We appreciate your input on this manual. To help, there are postage paid post cards included at the back. If you find any errors or want to comment on the layout of the manual please fill out one of the cards and mail it back to us.

COPYRIGHT® 1995  
 JOHN DEERE LAWN AND  
 GROUNDS CARE DIVISION  
 Horicon, Wisconsin  
 All rights reserved

<b>Safety</b>	
<b>Specifications and Information</b>	
<b>Backhoes</b>	
<b>Loaders</b>	
<b>Tillers</b>	
<b>Blades</b>	
<b>Hydraulic Dump</b>	
<b>Miscellaneous</b>	<b>M</b>



## **RECOGNIZE SAFETY INFORMATION**

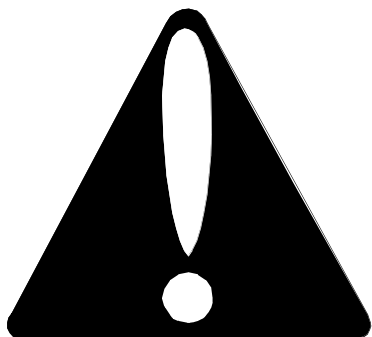

This is the safety-alert symbol. When you see this symbol on your machine or in this manual, be alert to the potential for personal injury.

Follow recommended precautions and safe servicing practices.

### **Understand Signal Words**

A signal word—DANGER, WARNING, or CAUTION—is used with the safety-alert symbol. DANGER identifies the most serious hazards.

DANGER or WARNING safety signs are located near specific hazards. General precautions are listed on CAUTION safety signs. CAUTION also calls attention to safety messages in this manual.

## **REPLACE SAFETY SIGNS**



TS201

Replace missing or damaged safety signs. See the machine operator's manual for correct safety sign placement.

## **HANDLE FLUIDS SAFELY-AVOID FIRES**

### **Be Prepared For Emergencies**



TS227

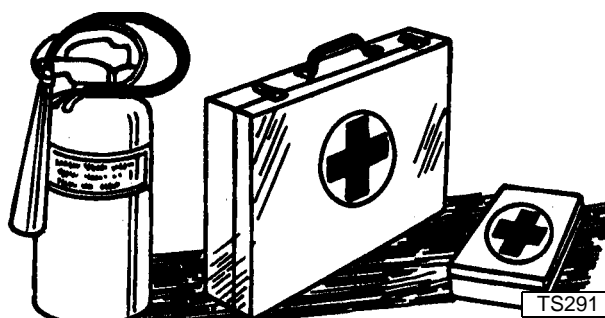

TS291

When you work around fuel, do not smoke or work near heaters or other fire hazards.

Store flammable fluids away from fire hazards. Do not incinerate or puncture pressurized containers.

Make sure machine is clean of trash, grease, and debris.

Do not store oily rags; they can ignite and burn spontaneously.

Be prepared if a fire starts.

Keep a first aid kit and fire extinguisher handy.

Keep emergency numbers for doctors, ambulance service, hospital, and fire department near your telephone.

**<https://www.ebooklibonline.com>**

Hello dear friend!

Thank you very much for reading.

Enter the link into your browser.

The full manual is available for immediate download.

**<https://www.ebooklibonline.com>**

## USE CARE AROUND HIGH-PRESSURE FLUID LINES

### Avoid High-pressure Fluids

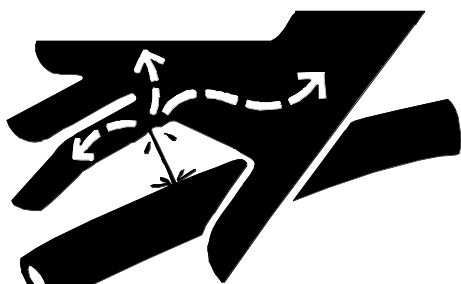

Escaping fluid under pressure can penetrate the skin causing serious injury.

Avoid injury from escaping fluid under pressure by stopping the engine and relieving pressure in the system before disconnecting or connecting hydraulic or other lines. Tighten all connections before applying pressure.

Search for leaks with a piece of cardboard. Protect hands and body from high pressure fluids.

If an accident occurs, see a doctor immediately. Any fluid injected into the skin must be surgically removed within a few hours or gangrene may result. Doctors unfamiliar with this type of injury should reference a knowledgeable medical source. Such information is available from Deere & Company Medical Department in Moline, Illinois, U.S.A.

### Avoid Heating Near Pressurized Fluid Lines



TS953

Flammable spray can be generated by heating near pressurized fluid lines, resulting in severe burns to yourself and bystanders. Do not heat by welding, soldering, or using a torch near pressurized fluid lines or other flammable materials. Pressurized lines can be accidentally cut when heat goes beyond the immediate flame area.

## USE SAFE SERVICE PROCEDURES

### Wear Protective Clothing



Wear close fitting clothing and safety equipment appropriate to the job.

Prolonged exposure to loud noise can cause impairment or loss of hearing. Wear a suitable hearing protective device such as earmuffs or earplugs to protect against objectionable or uncomfortable loud noises.

Operating equipment safely requires the full attention of the operator. Do not wear radio or music headphones while operating machine.

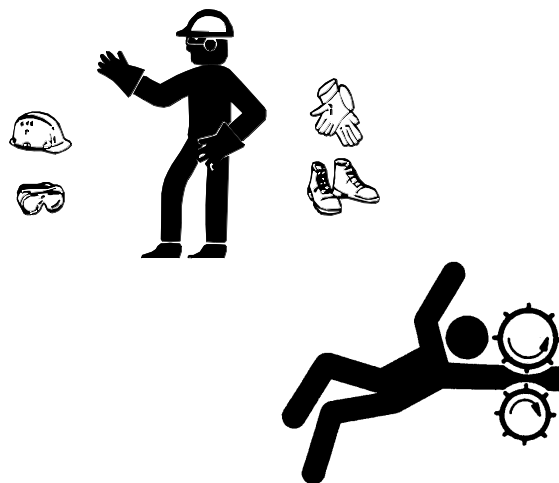

TS228

### Service Machines Safely

Tie long hair behind your head. Do not wear a necktie, scarf, loose clothing, or necklace when you work near machine tools or moving parts. If these items were to get caught, severe injury could result.

Remove rings and other jewelry to prevent electrical shorts and entanglement in moving parts.

### Use Proper Tools

Use tools appropriate to the work. Makeshift tools and procedures can create safety hazards. Use power tools only to loosen threaded parts and fasteners. For loosening and tightening hardware, use the correct size tools. **DO NOT** use U.S. measurement tools on metric fasteners. Avoid bodily injury caused by slipping wrenches. Use only service parts meeting John Deere specifications.



## Park Machine Safely

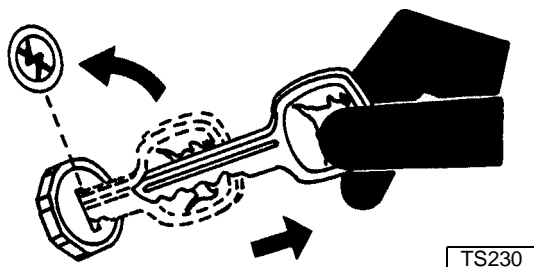

TS230

### Before working on the machine:

1. Lower all equipment to the ground.
2. Stop the engine and remove the key.
3. Disconnect the battery ground strap.
4. Hang a "DO NOT OPERATE" tag in operator station.

## Support Machine Properly And Use Proper Lifting Equipment

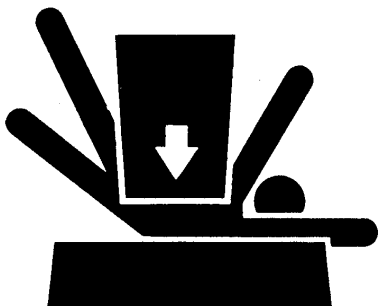

TS229

If you must work on a lifted machine or attachment, securely support the machine or attachment.

Do not support the machine on cinder blocks, hollow tiles, or props that may crumble under continuous load. Do not work under a machine that is supported solely by a jack. Follow recommended procedures in this manual.

Lifting heavy components incorrectly can cause severe injury or machine damage. Follow recommended procedure for removal and installation of components in the manual.

## Work In Clean Area

### Before starting a job:

1. Clean work area and machine.
2. Make sure you have all necessary tools to do your job.
3. Have the right parts on hand.
4. Read all instructions thoroughly; do not attempt shortcuts.

## Using High Pressure Washers

Directing pressurized water at electronic/electrical components or connectors, bearings, hydraulic seals, fuel injection pumps or other sensitive parts and components may cause product malfunctions. Reduce pressure and spray at a 45 to 90 degree angle.

## Illuminate Work Area Safely

Illuminate your work area adequately but safely. Use a portable safety light for working inside or under the machine. Make sure the bulb is enclosed by a wire cage. The hot filament of an accidentally broken bulb can ignite spilled fuel or oil.

## Work In Ventilated Area

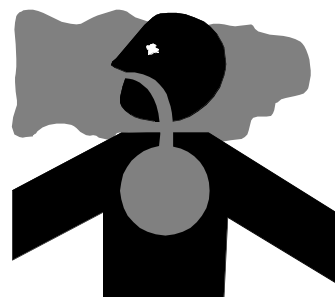

Engine exhaust fumes can cause sickness or death. If it is necessary to run an engine in an enclosed area, remove the exhaust fumes from the area with an exhaust pipe extension.

If you do not have an exhaust pipe extension, open the doors and get outside air into the area.

## Remove Paint Before Welding Or Heating

Avoid potentially toxic fumes and dust. Hazardous fumes can be generated when paint is heated by welding, soldering, or using a torch. Do all work outside or in a well ventilated area. Dispose of paint and solvent properly. Remove paint before welding or heating: If you sand or grind paint, avoid breathing the dust. Wear an approved respirator. If you use solvent or paint stripper, remove stripper with soap and water before welding. Remove solvent or paint stripper containers and other flammable material from area. Allow fumes to disperse at least 15 minutes before welding or heating.

## AVOID INJURY FROM ROTATING BLADES, AUGERS AND PTO SHAFTS

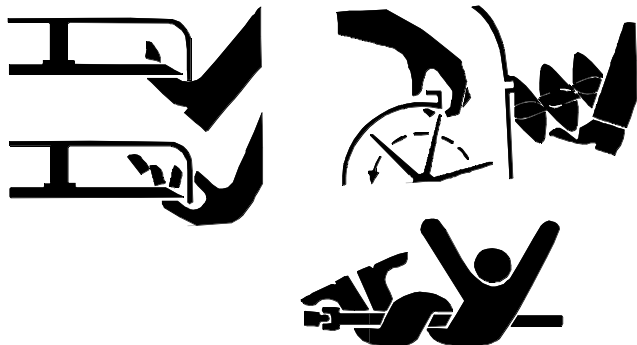

Keep hands and feet away while machine is running. Shut off power to service, lubricate or remove mower blades, augers or PTO shafts.

## HANDLE CHEMICAL PRODUCTS SAFELY

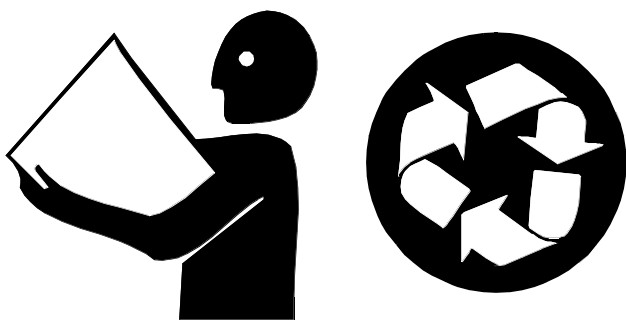

Direct exposure to hazardous chemicals can cause serious injury. Potentially hazardous chemicals used with John Deere equipment include such items as lubricants, coolants, paints, and adhesives.

A Material Safety Data Sheet (MSDS) provides specific details on chemical products: physical and health hazards, safety procedures, and emergency response techniques. Check the MSDS before you start any job using a hazardous chemical. That way you will know exactly what the risks are and how to do the job safely. Then follow procedures and recommended equipment.

## Dispose of Waste Properly

Improperly disposing of waste can threaten the environment and ecology. Potentially harmful waste used with John Deere equipment include such items as oil, fuel, coolant, brake fluid, filters, and batteries. Use leakproof containers when draining fluids. Do not use food or beverage containers that may mislead someone into drinking from them. Do not pour waste onto the ground, down a drain, or into any water source. Inquire on the proper way to recycle or dispose of waste from your local environmental or recycling center, or from your John Deere dealer.



## LIVE WITH SAFETY



Before returning machine to customer, make sure machine is functioning properly, especially the safety systems. Install all guards and shields.

# CONTENTS

Page



## SPECIFICATIONS AND INFORMATION

<b>7, 8, 8A, 10, &amp; 10A BACKHOES</b> .....	<b>3</b>
HYDRAULIC SYSTEM REQUIREMENTS AND SPECIFICATIONS .....	3
BACKHOE HYDRAULIC SPECIFICATIONS .....	3
INTERNAL VALVE LEAKAGE .....	4
LIFT CYLINDER DROP RATE .....	4
STABILIZER CYLINDER DROP RATE .....	4
STABILIZER CYLINDER RETRACT RATE .....	4
7 BACKHOE FUNCTION TIMES .....	5
8 AND 8A BACKHOE FUNCTION TIMES—TRACTORS .....	5
8 AND 8A BACKHOE FUNCTION TIMES—SKID-STEER LOADERS .....	6
10 AND 10A BACKHOE FUNCTION TIMES .....	6
<b>LOADERS</b> .....	<b>7</b>
CAPACITY—44 Loader, 316, 318, 330, 420 and 430 Tractor .....	7
CAPACITY—40 Loader, 415, 425, 445 and 455 Tractor (Two-Wheel Steer) .....	7
CAPACITY—60 Loader, 650, and 655 Tractor .....	7
CAPACITY—60 Loader, 670 Tractor .....	7
CAPACITY—70, Loader, 750 Tractor .....	7
CAPACITY—70, 70A Loader, 755, 770 and 855 Tractor .....	7
CAPACITY—70A Loader, 955 Tractor .....	7
DIMENSIONS—40 Loader, 415, 425, 445, 455 (Two-Wheel Steer) .....	8
DIMENSIONS—44 LOADER .....	9
DIMENSIONS—60, 70, 70A .....	10
CYCLE TIMES .....	11
BUCKET STRUCK CAPACITY .....	11
INTERNAL VALVE LEAKAGE .....	11
LIFT CYLINDER DROP RATE .....	11
BUCKET CYLINDER DROP RATE .....	11
<b>FITTINGS</b> .....	<b>12</b>
SERVICE RECOMMENDATIONS FOR O-RING BOSS FITTINGS .....	12
SERVICE RECOMMENDATIONS FOR FLAT FACE O-RING SEAL FITTINGS .....	13
FLAT FACE O-RING SEAL FITTING TORQUE .....	13
<b>UNIFIED INCH TORQUE VALUES</b> .....	<b>14</b>
<b>METRIC TORQUE VALUES</b> .....	<b>15</b>
<b>LUBRICANTS</b> .....	<b>16</b>
GREASE .....	16
ANTI-CHATTER TRANSMISSION/HYDRAULIC OIL .....	16
ALTERNATIVE LUBRICANTS .....	16
LUBRICANT STORAGE .....	16

## 7, 8, 8A, 10, & 10A BACKHOES

### HYDRAULIC SYSTEM REQUIREMENTS AND SPECIFICATIONS



#### Hydraulic Pump Flow Rates

650	18.2 L/min (4.8 gpm), 2600 RPM—Eng.
650 w/Power Steering	14.6 L/min (3.7 gpm), 2600 RPM—Eng.
750	21.6 L/min (5.7 gpm), 2400 RPM—Eng.
750 w/Power Steering	17.4 L/min (4.6 gpm), 2400 RPM—Eng.
755	15.4 L/min (3.9 gpm), 3200 RPM—Eng.
850 (9 cc)	23.5 L/min (6.2 gpm), 2600 RPM—Eng.
850 (9 cc) w/Power Steering	16.7 L/min (4.4 gpm), 2600 RPM—Eng.
850 (11 cc)	28.8 L/min (4.4 gpm), 2600 RPM—Eng.
850 (11 cc) w/Power Steering	22 L/min (5.8 gpm), 2600 RPM—Eng.
855	15.4 L/min (3.9 gpm), 3200 RPM—Eng.
950, 1050 (9 cc) w/Power Steering	14.8 L/min (3.9 gpm), 2400 RPM—Eng.
950, 1050 (11 cc)	26.5 L/min (7.0 gpm), 2400 RPM—Eng.
950, 1050 (11 cc) w/Power Steering	19.7 L/min (5.2 gpm), 2400 RPM—Eng.
5200, 5300, 5400	43.2 L/min (11.4 gpm), 2500 RPM—Eng.
570 Skid-Steer Loader	27.2 L/min (7.2 gpm), 2500 RPM—Eng.
575 Skid-Steer Loader	30.3 L/min (8.0 gpm), 2800 RPM—Eng.
675 Skid-Steer Loader	53.0 L/min (14.0 gpm), 2800 RPM—Eng.

### BACKHOE HYDRAULIC SPECIFICATIONS

#### Main System Relief Valve

Test Engine Speed	1500 RPM
Pressure	
7 Backhoe	11713 (10680 min.) kPa (117.3 [106.9 min.] bar) (1700 [1550 min.] psi)
8 & 8A Backhoe	14124.5 [13091.5 min.] kPa (141.5 [131.1 min.] bar) (2050 [1900 min.] psi)
10A Backhoe	15847 [14814 min.] kPa (158.7 [148.3 min.] bar) (2300 [2150 min.] psi)

#### Circuit Relief Valve Setting

Boom and Dipperstick	
7 Backhoe	14469 ±689 kPa (79 ±5 bar) (2100 ±100 psi)
8, 8A, 10 and 10A Backhoe	19981 ±689.5 kPa (179.5 ±6.5 bar) (2600 ±100 psi)
Shim Sizes	
7 and 8, 8A Backhoe	1.02 mm (0.04 in.), 0.51 mm (0.02 in.), (0.254 mm (0.01 in.))

#### Crossover Relief Valve Setting

Test Engine Speed	800 RPM
7, 8, and 8A Backhoe	7407—8440 kPa (74.2—84.5 bar) (1075—1225 psi)
10 and 10A Backhoe	10335—11369 kPa (103.5—113.9 bar) (1500—1650 psi)

#### Boom

Restrictor Orifice I.D.	
7 Backhoe	1.575 mm (0.062 in.)
8 and 8A Backhoe	1.88 mm (0.074 in.),
10 and 10A Backhoe	1.88 mm (0.074 in.)

**Swing**

Restrictor Orifice I.D. (2)

7 Backhoe . . . . . 1.575 mm (0.062 in.)

8 and 8A Backhoe . . . . . 1.19 mm (0.046 in.)

10 and 10A Backhoe . . . . . 1.4 mm (0.055 in.)

**Stabilizer**

Restrictor Orifice I.D. (2)

7 Backhoe (after Nov. 1989). . . . . 1.575 mm (0.062 in.)

8 and 8A Backhoe (after April 1990) . . . . . 1.88 mm (0.074 in.)

**INTERNAL VALVE LEAKAGE****(Maximum acceptable limit)**

Stabilizer Circuit . . . . . 12 ML/min (0.73 cu. in./min)

Lift Circuit (with relief and check) . . . . . 22 ML/min (1.34 cu.in./min)

**LIFT CYLINDER DROP RATE****(Maximum acceptable limit from transport position)**

7 . . . . . 14.48 mm/min (.57 in./min)

8, 8A . . . . . 9.15 mm/min (.36 in./min)

10, 10A . . . . . 7.62 mm/min (.30 in./min)

**STABILIZER CYLINDER DROP RATE****(Maximum acceptable limit from transport position)**

7 . . . . . 8.64 mm/min (.34 in./min)

8, 8A . . . . . 5.85 mm/min (.23 in./min)

10, 10A . . . . . 5.85 mm/min (.23 in./min)

**STABILIZER CYLINDER RETRACT RATE****(Maximum acceptable limit from working position)**

7 . . . . . 5.85 mm/min (.23 in./min)

8, 8A . . . . . 3.81 mm/min (.15 in./min)

10, 10A . . . . . 3.81 mm/min (.15 in./min)

## 7 BACKHOE FUNCTION TIMES

NOTE: All times in seconds.

	MODEL								
	650	650 w/p.s. <sup>b</sup>	670 w/p.s. <sup>b</sup>	750	750 w/p.s. <sup>b</sup>	770 w/p.s. <sup>b</sup>	755	855	955 w/p.s. <sup>b</sup>
Boom up*	2.1	2.7	2.0	1.8	2.2	2.0	1.8	1.8	1.6
Boom down*	2.5	3.2	2.3	2.1	2.6	2.4	2.3	2.3	2.1
Dipperstick in	3.0	3.8	2.8	2.5	3.1	2.8	3.5	3.5	3.2
Dipper stick out	2.3	3.0	2.2	2.0	2.5	2.2	2.9	2.9	2.6
Bucket open	2.0	2.6	1.9	1.7	2.1	1.9	2.0	2.0	1.8
Bucket closed	2.3	3.0	2.2	2.0	2.5	2.2	2.6	2.6	2.3
Swing left to right	2.5	2.5	2.8	2.5	2.5	2.8	2.8	2.8	2.5
Swing right to left	2.5	2.5	2.8	2.5	2.5	2.8	2.8	2.8	2.5
Stabilizer up	1.2	1.5	1.2	1.0	1.2	1.1	1.6	1.6	1.7
Stabilizer down	1.7	2.3	1.7	1.5	1.8	1.7	2.3	2.3	2.1

\*Arm extended, bucket in closed position, ground level to full boom extension.

<sup>b</sup> With power steering.

## 8 AND 8A BACKHOE FUNCTION TIMES—TRACTORS

NOTE: All times in seconds

	MODEL										
	850	850 9 cc pump w/p.s. <sup>b</sup>	870	950, 1050 9 cc pump	950, 1050 9 cc pump w/p.s. <sup>b</sup>	970	850 11 cc pump	850 11 cc pump w/p.s. <sup>b</sup>	950, 1050 11 cc pump	950, 1050 11 cc pump w/p.s. <sup>b</sup>	1070
Boom up*	2.4	3.4	2.0	2.6	3.9	2.0	2.0	2.6	2.2	2.9	1.9
Boom down*	2.8	3.9	2.3	3.0	4.4	2.3	2.3	3.0	2.5	3.3	2.2
Dipperstick in	4.4	6.3	3.5	4.8	7.1	3.5	3.7	4.8	3.9	5.3	3.4
Dipper stick out	3.5	5.0	2.8	3.8	5.6	2.8	2.9	3.8	3.1	4.2	2.7
Bucket open	2.2	3.1	1.7	2.4	3.5	1.7	1.8	2.3	1.9	2.6	1.6
Bucket closed	2.9	4.1	2.6	3.2	4.7	2.6	2.4	3.1	2.6	3.5	2.2
Swing left to right	3.5	5.0	3.8	3.9	5.7	3.8	4.2	4.2	4.2	4.2	3.6
Swing right to left	3.5	5.0	3.8	3.9	5.7	3.8	4.2	4.2	4.2	4.2	3.6
Stabilizer up	2.0	2.8	1.6	2.2	3.2	1.6	1.7	2.2	1.8	2.4	2.1
Stabilizer down	3.2	4.5	2.5	3.5	5.1	2.5	2.6	3.4	2.8	3.8	2.4

\*Arm extended, bucket in closed position, ground level to full boom extension.

<sup>b</sup> With power steering.



## 8 AND 8A BACKHOE FUNCTION TIMES—SKID-STEER LOADERS

NOTE: All times in seconds.



	MODEL			
	570	575	675	675B
Boom up*	7.8	7.0	4.0	4.0
Boom down*	6.7	6.0	3.4	3.4
Dipperstick in	5.6	5.0	2.9	2.9
Dipper stick out	6.7	6.0	3.4	3.4
Bucket open	3.4	3.8	2.2	2.2
Bucket closed	3.8	4.2	2.4	2.4
Swing left to right	5.0	5.0	5.0	5.0
Swing right to left	5.0	5.0	5.0	5.0
Stabilizer up	2.9	2.6	1.7	1.7
Stabilizer down	2.9	2.6	1.7	1.7

\*Arm extended, bucket in closed position, ground level to full boom extension.

## 10 AND 10A BACKHOE FUNCTION TIMES

NOTE: All times in seconds.

	MODEL							
	1250	1450	1650	2150	2350 13 GPM	2350 23 GPM	5000 SERIES	675, 675B SSL
Boom up*	3.3	3.4	3.6	2.8	2.8	1.6	3.2	5.3
Boom down*	3.1	3.2	3.3	2.6	2.6	1.5	3.0	1.0
Dipperstick in	1.2	1.3	1.3	1.1	1.1	0.6	1.3	2.4
Dipper stick out	1.5	1.5	1.6	1.2	1.2	0.7	1.4	2.0
Bucket open	1.5	1.5	1.6	1.2	1.2	0.7	1.4	2.0
Bucket closed	1.2	1.3	1.3	1.1	1.1	0.6	1.3	3.0
Swing left to right	5.0	5.0	5.0	5.0	5.0	5.0	5.7	5.0
Swing right to left	5.0	5.0	5.0	5.0	5.0	5.0	5.7	5.0
Stabilizer up	2.3	2.4	2.5	1.9	1.9	1.1	1.3	1.5
Stabilizer down	2.3	2.4	2.5	1.9	1.9	1.1	1.3	1.5

\*Arm extended, bucket in closed position, ground level to full boom extension.

**LOADERS**

**CAPACITY—44 Loader, 316, 318, 330, 420 and 430 Tractor**

	<b>316, 318 &amp; 330</b>	<b>420 &amp; 430</b>
Lift Capacity .....	180 kg (400 lb.)	225 kg (500 lb.)
Rated Breakout Capacity .....	260 kg (575 lb.)	328 kg (725 lb.)
1220 mm (48 in.) Bucket .....	0.164 m <sup>3</sup> (5.80 ft. <sup>3</sup> )	
1370 mm (54 in.) Bucket .....	0.185 m <sup>3</sup> (6.54 ft. <sup>3</sup> )	



**CAPACITY—40 Loader, 415, 425, 445 and 455 Tractor (Two-Wheel Steer)**

Lift Capacity at Full Height .....	.98 kg (215 lb.)
at 900 mm (36 in.) .....	.159 kg (350 lb.)
Breakout (Boom) .....	.226 kg (500 lb.)
Breakout (Bucket) .....	.272 kg (600 lb.)

**CAPACITY—60 Loader, 650, and 655 Tractor**

Lift Capacity at Full Height .....	.273 kg (600 lb.)
at 450 mm (18 in.) .....	.385 kg (845 lb.)
at 900 mm (36 in.) .....	.335 kg (735 lb.)
Breakout (Boom) .....	4010 N (900 lb.)
Breakout (Bucket) .....	6660 N (1495 lb.)

**CAPACITY—60 Loader, 670 Tractor**

Lift Capacity at Full Height .....	.297 kg (655 lb.)
at 450 mm (18 in.) .....	.385 kg (845 lb.)
at 900 mm (36 in.) .....	.335 kg (735 lb.)
Breakout (Boom) .....	4010 N (900 lb.)
Breakout (Bucket) .....	6660 N (1495 lb.)

**CAPACITY—70, Loader, 750 Tractor**

Lift Capacity at Full Height .....	.318 kg (700 lb.)
at 450 mm (18 in.) .....	.540 kg (1190 lb.)
at 900 mm (36 in.) .....	.460 kg (1010 lb.)
at 1800 mm (72 in.) .....	.335 kg (735 lb.)
Breakout (Boom) .....	5790 N (1300 lb.)
Breakout (Bucket) .....	6995 N (1570 lb.)

**CAPACITY—70, 70A Loader, 755, 770 and 855 Tractor**

Lift Capacity at Full Height .....	.342 kg (755 lb.)
at 450 mm (18 in.) .....	.540 kg (1190 lb.)
at 900 mm (36 in.) .....	.460 kg (1010 lb.)
at 1800 mm (72 in.) .....	.335 kg (735 lb.)
Breakout (Boom) .....	5790 N (1300 lb.)
Breakout (Bucket) .....	6995 N (1570 lb.)

**CAPACITY—70A Loader, 955 Tractor**

Lift Capacity at Full Height .....	.422 kg (930 lb.)
at 450 mm (18 in.) .....	.659 kg (1450 lb.)
at 900 mm (36 in.) .....	.559 kg (1230 lb.)
at 1800 mm (72 in.) .....	.407 kg (895 lb.)
Breakout (Boom) .....	7060 N (1585 lb.)
Breakout (Bucket) .....	8530 N (1915 lb.)

**DIMENSIONS—40 Loader, 415, 425, 445, 455  
(Two-Wheel Steer)**

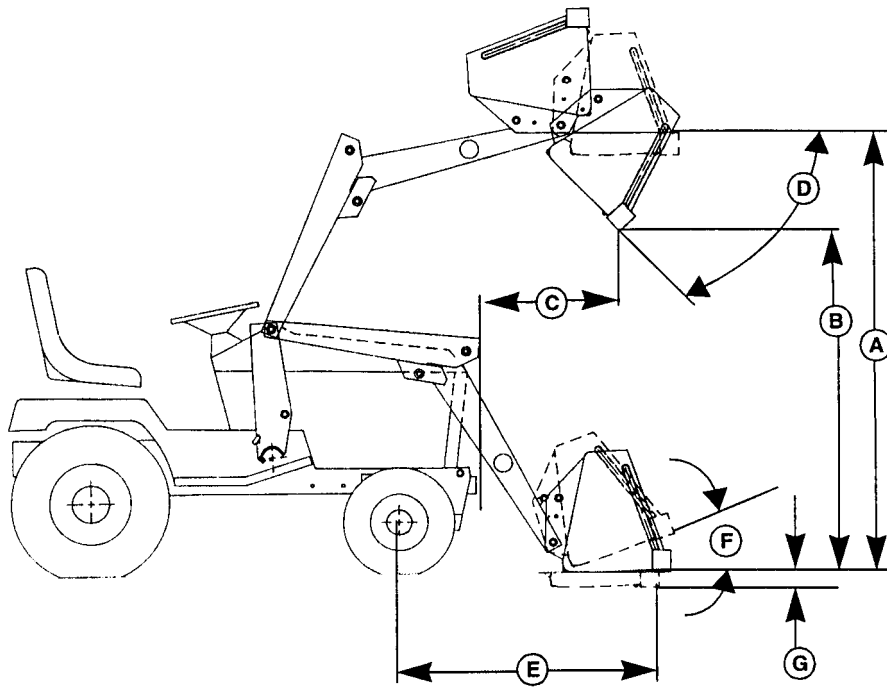

M78226

**Tractor Tire Size Specifications**

Front	16x6050-8 4 PR	18x8.50-8 4 PR
Rear	23x10.50-12 2 PR	26x12.00-12 2 PR

**Loader Dimensions**

A—Maximum Lift Height (lowest point on bucket)	175 cm (69 in.)	178 cm (70 in.)
B—Maximum Clearance Under Fully Dumped Bucket	132 cm (52 in.)	135 cm (53 in.)
C—Reach With Fully Dumped Bucket 45°	65 cm (25.5 in.)	65 cm (25.5 in.)
D—Maximum Bucket Dump Angle	50°	50°
E—Reach With Bucket On Ground	109 cm (43 in.)	108 cm (42.5 in.)
F—Bucket Rollback Angle On Ground	19°	18°
G—Digging Depth Below Ground	10 cm (4 in.)	8 cm (3 in.)

**Required Tractor Ballasting**

w/23 in. Tires	Minimum of 295 kg (650 lb.) rear ballast, 113 kg (250 lb.) on rear wheels
w/26 in. Tires	Minimum of 340 kg (750 lb.) rear ballast, 113 kg (250 lb.) on rear wheels

**Hydraulic System**

Pump, Reservoir, and Controls	Tractor
Rated Pressure	6890 kPa (1000 psi)
Lift Cylinder Diameter	38 mm (1.5 in.)
Bucket Cylinder Diameter	44 mm (1.75 in.)

**DIMENSIONS—44 LOADER**

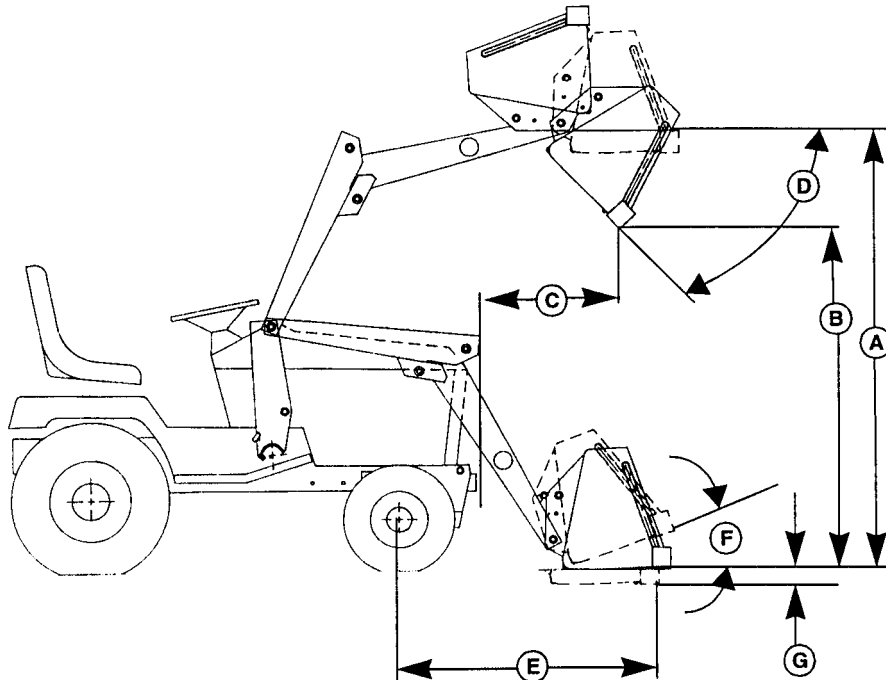

M78226

<b>Loader Dimensions</b>	<b>316, 318, &amp; 330</b>	<b>420</b>	<b>430</b>
A—Maximum Lift Height (lowest point on bucket)	1816 mm (71.5 in.)	1854 mm (73 in.)	1854 mm (73 in.)
B—Maximum Clearance (Fully Dumped Bucket)	1320 mm (52 in.)	1358 mm (53.5 in.)	1358 mm (53.5 in.)
C—Reach (Fully Dumped Bucket 45°)	533 mm (21 in.)	558 mm (22 in.)	558 mm (22 in.)
D—Maximum Bucket Dump Angle	50°	50°	50°
E—Reach With Bucket On Ground	1117 mm (44 in.)	1130 mm (44.5 in.)	1300 mm (51.25 in.)
F—Bucket Rollback Angle	20°	20°	20°
G—Digging Depth Below Ground	114 mm (4.5 in.)	100 mm (4 in.)	100 mm (4 in.)

*NOTE: Operating dimensions vary with tractor size, and bucket used. Dimensions for the 44 Loader are given on the John Deere 318 Tractor with 6.50x16 front tires, 10.5x23 rear tires and a 1220 mm (48 in.) bucket. The John Deere 420 and 430 Tractors are equipped with 8.50x18 front tires, 12.00x26 rear tires and a 1220 mm (48 in.) bucket.*

**Required Tractor Ballasting**

34 kg (75 lb.) of rear wheel weights (total), Maximum liquid in rear tires, & 77 kg (170 lb.) on rear wheels (min.)

<b>Hydraulic System</b>	<b>316, 318 &amp; 330</b>	<b>420 &amp; 430</b>
Pump, Reservoir, and Controls	Independent	Independent
Rated Pressure	6890 kPa (1000 psi)	8274 kPa (1200 psi)
Lift Cylinder Diameter	44 mm (1.75 in.)	44 mm (1.75 in.)
Bucket Cylinder Diameter	44 mm (1.75 in.)	44 mm (1.75 in.)
Lift Cylinder Stroke	44 mm (1.75 in.)	44 mm (1.75 in.)
Bucket Cylinder Stroke	466 mm (18.38 in.)	368 mm (14.5 in.)

DIMENSIONS—60, 70, 70A

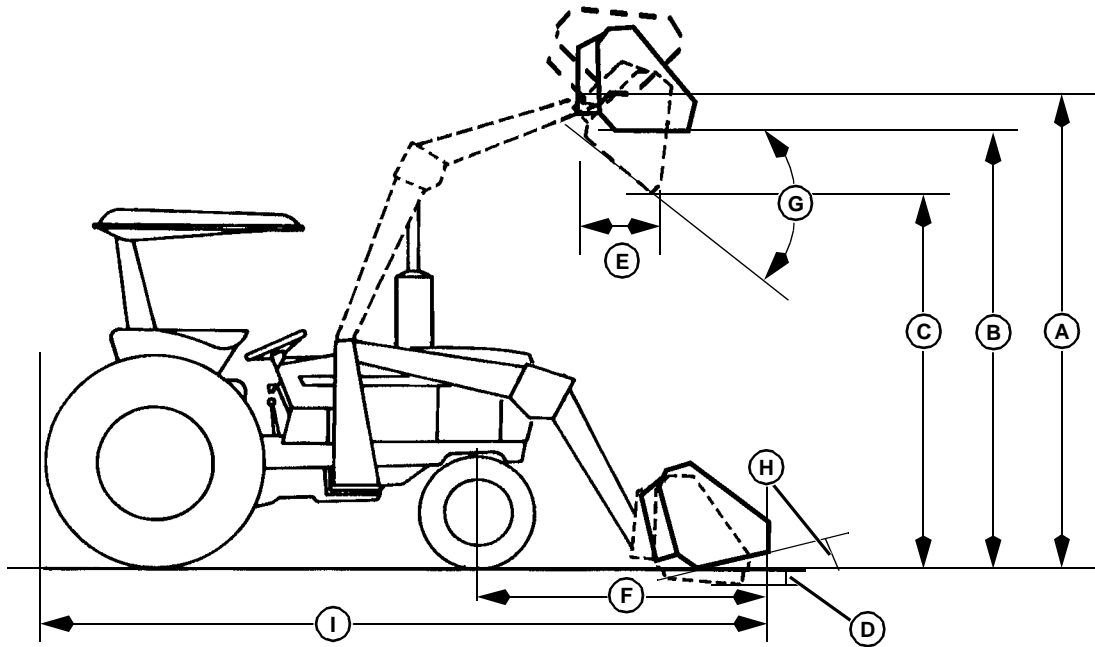

M78221

MODEL

	60 Loader 655 Tractor	60 Loader 650 Tractor	60 Loader 670 Tractor	70 Loader 755 Tractor	70A Loader 855 Tractor	70 Loader 750 Tractor	70 Loader 770 Tractor	70A Loader 955 Tractor
A—Maximum Lift Height)	1765 mm (69.5 in.)	1765 mm (69.5 in.)	1765 mm (69.5 in.)	1965 mm (77.3 in.)	1965 mm (77.3 in.)	1965 mm (77.3 in.)	1965 mm (77.3 in.)	1965 mm (77.3 in.)
B—Clearance With Bucket Level	1670 mm (65.8 in.)	1670 mm (65.8 in.)	1670 mm (65.8 in.)	1875 mm (73.8 in.)	1875 mm (73.8 in.)	1875 mm (73.8 in.)	1875 mm (73.8 in.)	1875 mm (73.8 in.)
C—Clearance With Bucket Dumped	1370 mm (54 in.)	1370 mm (54 in.)	1370 mm (54 in.)	1575 mm (62 in.)	1575 mm (62 in.)	1575 mm (62 in.)	1575 mm (62 in.)	1575 mm (62 in.)
D—Clearance, Digging Depth	125 mm (5 in.)	125 mm (5 in.)	125 mm (5 in.)	125 mm (5 in.)	125 mm (5 in.)	125 mm (5 in.)	125 mm (5 in.)	125 mm (5 in.)
E—Reach at max. Height & Dumped	655 mm (25.8 in.)	655 mm (25.8 in.)	700 mm (27.5 in.)	700 mm (27.5 in.)	700 mm (27.5 in.)	685 mm (27 in.)	762 mm (30 in.)	787 mm (31 in.)
F—Reach at Ground Level & Level	1265 mm (49.8 in.)	1255 mm (49.5 in.)	1265 mm (49.8 in.)	1215 mm (47.8 in.)	1215 mm (47.8 in.)	1265 mm (49.8 in.)	1219 mm (48 in.)	1219 mm (48 in.)
G—Max. Dump Angle	45°	45°	45°	45°	45°	45°	45°	45°
H—Rollback Angle on Ground	22°	22°	22°	22°	22°	22°	22°	22°
I—Overall Length	2980 mm (117.2 in.)	3100 mm (122.1 in.)	3080 mm (121.2 in.)	3080 mm (121.2 in.)	3255 mm (128.2 in.)	3340 mm (131.5 in.)	3107 mm (125.5 in.)	3225 mm (127 in.)

Based On Tractor Tire Size:

• Front	6-12	6-12	6-12	6-12	6-12	6-12	6-12	25x8.5-14
• Rear	9.5-16	9.5-16	9.5-16	9.5-16	9.5-16	9.5-16	9.5-16	36x13.5-15

## CYCLE TIMES

NOTE: All times in seconds



	MODEL							
	60 Loader 655 Tractor	60 Loader 650 Tractor	60 Loader 670 tractor	70 Loader 755 Tractor	70A Loader 855 Tractor	70 Loader 750 Tractor	70 Loader 770 Tractor	70A Loader 955 Tractor
Loader raising time	4.3	4.8	2.2	3.2	3.2	3.9	2.7	2.8
Loader lowering time	2.7	5.4	2.0	2.0	2.0	5.5	2.6	2.4
Bucket dumping time	3.7	4.3	2.1	2.2	2.2	3.6	2.0	2.5
Bucket rollback time	3.6	1.7	1.7	2.2	2.2	1.5	2.0	2.1
Hydraulic flow	15 L/m 4.0 gpm	21.1 L/m 5.6 gpm	20.9 L/m 5.5 gpm	21.1 L/m 5.6gpm	21.1 L/m 5.6gpm	23.9 L/m 6.3 gpm	21.1 L/m 5.6 gpm	27.6 L/m 7.2 gpm

Cycle times are based on flow rates at S.C.V. and with power steering.  
1220 mm (48 in.) bucket size used.

## BUCKET STRUCK CAPACITY

48-Inch . . . . .	0.17 mm <sup>3</sup> (6.2 cu-ft.)
54-Inch . . . . .	0.19 mm <sup>3</sup> (7.0 cu-ft.)
60-Inch . . . . .	0.22 mm <sup>3</sup> (7.8 cu-ft.)

## INTERNAL VALVE LEAKAGE

(Maximum acceptable limit)

655, 670, 770, 755, 855, and 955 . . . . .	12ML/min (0.73 cu. in.)
--	-------------------------

## LIFT CYLINDER DROP RATE

(Maximum acceptable limit from transport position)

60, 70, 70A . . . . .	10.4 mm/min (.41 in./min)
-----------------------	---------------------------

## BUCKET CYLINDER DROP RATE

(Maximum acceptable limit from rollback position)

60, 70, and 70A . . . . .	13 mm/min (.51 in./min)
---------------------------	-------------------------



**Suggest:**

**If the above button click is invalid.**

**Please download this document**

**first, and then click the above link**

**to download the complete manual.**

**Thank you so much for reading**

**FITTINGS**

**SERVICE RECOMMENDATIONS FOR O-RING BOSS FITTINGS**



**STRAIGHT FITTING**

1. Inspect O-ring boss seal for dirt or defects.
2. Lubricate O-rings with petroleum jelly. Place electrical tape over threads to protect O-ring. Slide O-ring over tape and into O-ring groove of fitting. Remove tape.
3. Tighten fitting to torque value shown on chart.

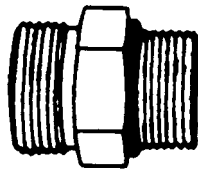

M82649A

**ANGLE FITTING**

1. Back-off lock nut (A) and back-up washer (B) completely to head-end (C) of fitting.
2. Turn fitting into threaded boss until back-up washer contacts face of boss.
3. Turn fitting head-end counterclockwise to proper index (maximum of one turn).
4. Hold fitting head-end with a wrench and tighten locknut and back-up washer to proper torque value.

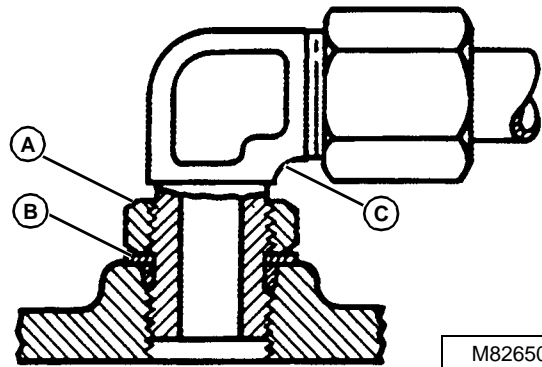

M82650A

*NOTE: Do not allow hoses to twist when tightening fittings.*

**TORQUE VALUE**

Thread Size	N•m	lb-ft
3/8-24 UNF	8	6
7/16-20 UNF	12	9
1/2-20 UNF	16	12
9/16-18 UNF	24	18
3/4-16 UNF	46	34
7/8-14UNF	62	46
1-1/16-12 UN	102	75
1-3/16-12 UN	122	90
1-5/16-12 UN	142	105
1-5/8-12 UN	190	140
1-7/8-12 UN	217	160

*NOTE: Torque tolerance is ± 10%*

**<https://www.ebooklibonline.com>**

Hello dear friend!

Thank you very much for reading.

Enter the link into your browser.

The full manual is available for immediate download.

**<https://www.ebooklibonline.com>**