

820 REAR TINE TILLER



JOHN DEERE

TECHNICAL MANUAL

820 REAR TINE TILLER

TM1297 (01JUL83) English

JOHN DEERE HORICON WORKS
TM1297 (01JUL83)

LITHO IN THE U.S.A.
ENGLISH

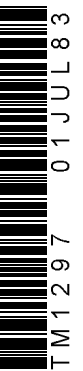

**820 REAR
TINE TILLER
TECHNICAL MANUAL
TM-1297 (JUL-83)**

CONTENTS

SECTION 10 - GENERAL

- Group 05 - Identification
- Group 10 - Safety
- Group 15 - Specifications
- Group 20 - Lubricants
- Group 25 - Engine Service

SECTION 20 - POWER TRAIN

- Group 05 - General Information
- Group 10 - Wheel Drive Transmission
- Group 15 - Tine Reversing Transmission
- Group 20 - Drive Sprocket, Chain and Axle
- Group 25 - Drive Belts

**SECTION 30 - WORM DRIVE TRANSMISSION
AND TINES**

- Group 05 - Worm Drive Transmission
- Group 10 - Tines

SECTION 40 - CONTROLS AND LINKAGE

- Group 05 - Drive Wheel Clutch Control
- Group 10 - Wheel Speed Control
- Group 15 - Tine Clutch
- Group 20 - Tine Direction Lever
- Group 25 - Handle Release
- Group 30 - Throttle Control Lever

SECTION 50 - ELECTRICAL SYSTEM

- Group 05 - General Information
- Group 10 - Battery
- Group 15 - Starter

All information, illustrations and specifications contained in this technical manual are based on the latest information available at the time of publication. The right is reserved to make changes at any time without notice.

Because John Deere sells its products world-wide, U.S. units of measure are shown with their respective Metric equivalents throughout this technical manual. These equivalents are the SI (International System) Units of Measure.

Copyright © 1983
Deere & Company
Moline, Illinois
All rights reserved
A JOHN DEERE ILLUSTRATION

FGP/A/050783

INTRODUCTION

This technical manual contains service and maintenance information for the John Deere 820 Rear Tine Tiller except for information pertaining to engine teardown and assembly. That information can be found in TM-1296, Horizontal Crankshaft, Small Engines.

The manual is divided into sections. Each section pertains to a certain component or operational system of the tiller. The information is divided into groups within each section.

Emphasis is placed on trouble shooting, analysis and testing. Trouble shooting includes possible troubles, their causes, and how to correct them. Under specific systems, these troubles are analyzed to help you understand what is causing the problem. In this way, you can eliminate the cause rather than just replace parts and have the same problem keep recurring.

Special Tools and Specifications are found at the beginning of each group for easy reference.

Whenever new or revised pages are provided, insert them into your manual as soon as you receive them. Your technical manual will always be up-to-date and be a valuable asset in your service department.

FGP/C/050783



This safety alert symbol identifies important safety messages in this manual. When you see this symbol, be alert to the possibility of personal injury and carefully read the message that follows.

This manual contains SI metric equivalents which are followed by the U.S. customary units of measure.

“Right-hand” and “left-hand” sides are determined by facing in the direction of tiller forward travel.

FGP/C/050783

<https://www.ebooklibonline.com>

Hello dear friend!

Thank you very much for reading.

Enter the link into your browser.

The full manual is available for immediate download.

<https://www.ebooklibonline.com>

Section 10 GENERAL

CONTENTS

	Page
GROUP 05 - IDENTIFICATION	
Identification	10-05-01
Tiller Serial Number	10-05-01
GROUP 10 - SAFETY	10-10-01
GROUP 15 - SPECIFICATIONS	10-15-01
GROUP 20 - LUBRICANTS	
Transmission Lubricants	10-20-01
Engine Oil	10-20-01
Alternative Lubricants	10-20-01
GROUP 25 - ENGINE SERVICE	
Remove Engine	10-25-01

IDENTIFICATION

- A—Throttle Control Lever
- B—Handle Bars
- C—Wheel Speed Lever
- D—Handle Release
- E—Tine Clutch Lever
- F—Clutch Handle
- G—Sheave Cover
- H—Fuel Tank
- I—Recoil Starter
- J—Front Weight
- K—Air Cleaner
- L—Wheel
- M—Ignition Switch (Electric Start)
- N—Tine Direction Lever
- O—Tines
- P—Tine Shield
- Q—Tine Depth Gauge

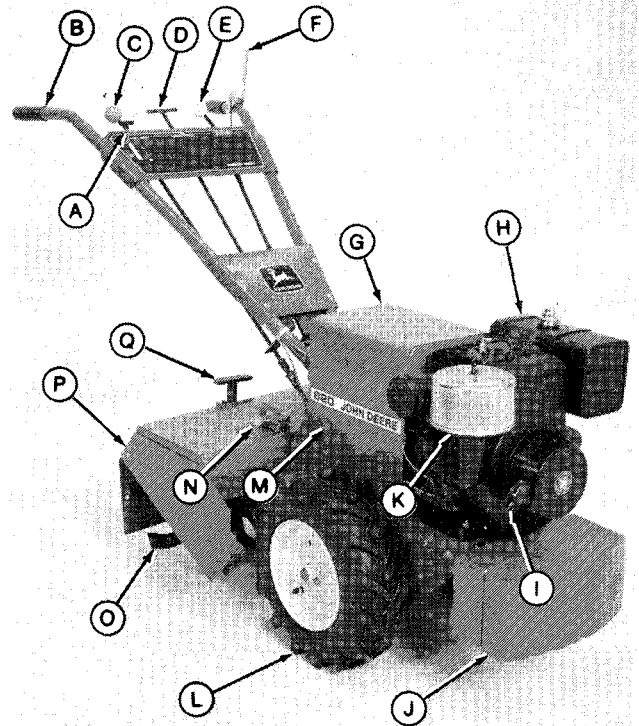

TY8514/F10/A/A/050783

TILLER SERIAL NUMBER

The tiller serial number (A) is located on the rear of the tine shield.

The letters "TY" denote JDM Division as the control factory.

When writing about or filling out warranty claims, use all numbers and letters on the tiller serial number plate.

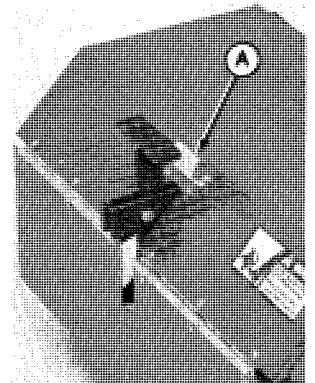

TY8512/F10/A/B/050783

FIRST AID KIT AND FIRE EXTINGUISHER

Be prepared if an accident or fire should occur. Know where the first aid kit and the fire extinguishers are located — know how to use them.



T27504N

127504F10B/A-050783

INSPECT TILLING AREA

Remove all debris (string, wire or cords) which might wrap around the tines.

Remove objects (sticks, stones, bottles or bones) that might be thrown by tiller.

F10B/B-050783

PREPARE FOR STARTING

Thoroughly inspect the area where the tiller is to be used. Remove all stones, sticks, wires, bones, and other foreign objects.

Do not operate the tiller when barefoot or wearing open sandals. Always wear substantial footwear.

Do not run engine indoors.

F10B/C-050783

PROTECT AGAINST NOISE

Prolonged exposure to loud noise can cause impairment or loss of hearing. Wear a suitable hearing protective device, such as earmuffs (A) or earplugs (B) to protect against objectionable or uncomfortable loud noise.

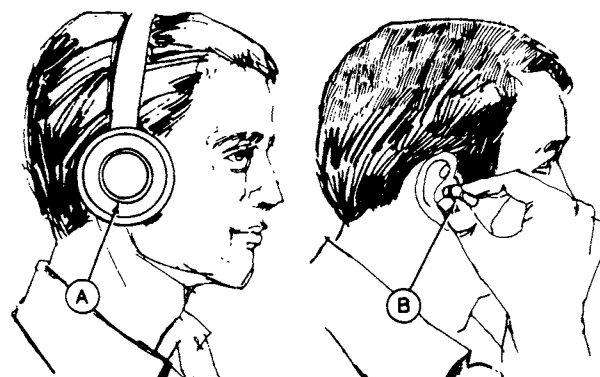

M28247/F10B/D-050783

OPERATE TILLER SAFELY

Always keep hands and feet away from tines, wheels and other moving parts.

Keep all shields in place.

Do not operate tiller in vicinity of other persons.

Disengage tine clutch before starting engine.

Stop engine whenever leaving operator's station.

Do not operate tiller too close to a ditch or terrace.

Be careful of your footing on slopes.

Check for breakage and repair any damage after striking a solid object.

Do not over-speed the engine or alter governor setting.

When operating tiller in reverse, move tine clutch to "STOP" position and throttle to "SLOW" position.

F10/B/E/050783

HANDLE FUEL SAFELY

Use a properly marked and approved safety container for storing fuel.

Refuel engine outdoors.

Shut off engine and allow it to cool before refueling.

Do not smoke while refueling engine or operating tiller.

Do not overflow gasoline while filling fuel tank.



TY9797/F10/B/F/050783

AVOID FIRES

Keep engine free of grass, leaves and excess grease and oil.

Allow engine to cool before refueling or moving tiller indoors.

Avoid spilling gasoline. Wipe up any spilled gasoline before starting engine.

Move tiller away from fueling area before starting engine.

F10/B/G/050783

WEAR PROPER PROTECTIVE EQUIPMENT

Earplugs or earmuffs.

Heavy work gloves.

Safety shoes with slip-resistant soles.

Close fitting work clothes.

F10B16650799

DO NOT MODIFY TILLER

Unauthorized modification to the tiller may impair the function and/or safety and affect tiller life.

F10B1056763

PRACTICE SAFE MAINTENANCE

Before servicing tiller, disconnect spark plug wire to help prevent accidental starting.

Disconnect battery on electric start models before performing maintenance or transporting tiller.

Keep all nuts, bolts and screws tight.

Do not touch muffler or other hot parts.

F10B1056763

SPECIFICATIONS

Engine	Briggs & Stratton, single cylinder, air-cooled
Engine Serial Number	195437-0282-01
Horsepower	5.9 kW (8.0 hp)
Engine Speed:	
Idle	1750 rpm
High	3700 rpm
Capacities:	
Crankcase	1.3 L (2.75 pt.)
Fuel Tank	3.8 L (4 qt.)
Battery (John Deere TY6024 or its equivalent)	12-volt Cold cranking amps @ (-18°C) 0°F - 160 @ (-29°C) -20°F + 110
Starting	Manual recoil start Electric start (TY6024 battery not included)
Spark Plug	John Deere TY6064 or its equivalent
Spark Plug Gap	0.762 mm (0.030-in.)
Spark Plug Torque	20 to 27 N·m (15 to 20 lb-ft)
Width of Tilling	650 mm (22 in.)
Depth Range	25 to 178 mm (1 to 7 in.)
Tire Size	4.80/4.00-8
Tire Pressure	83 kPa (12 psi)
Height	1067 mm (42 in.)
Width	635 mm (25 in.)
Weight	173 kg (380 lb.)

(Specifications and design subject to change without notice)

TRANSMISSION LUBRICANTS

Component	Capacity	Fill with John Deere lubricant or its equivalent	Service Interval
Wheel Drive Transmission	approximately (340g) 12 oz.	AT30408 John Deere High Temperature Grease	Only when disassembled
Tine Reversing Transmission	approximately (224g) 8 oz.	85w/140GL5 or SAE140 EP Gear Lubricant	Beginning of each season or every 25 hours of operation
Worm Drive Transmission	approximately (340g) 12 oz.	85w/140GL5 or SAE 140 EP Gear Lubricant	Beginning of each season or every 25 hours of operation

F*O/D/A C50783

ENGINE OIL

Depending on the expected air temperature range during the drain interval, use oil viscosity shown on the adjoining temperature chart.

IMPORTANT: Use John Deere TORQ-GARD SUPREME® or John Deere Plus 4®. If other oils are used, they must be premium quality engine oils meeting minimum performance requirements of API Service Classification SD, SE or SF.

Quality engine oils are blended, so additives are neither required nor recommended.

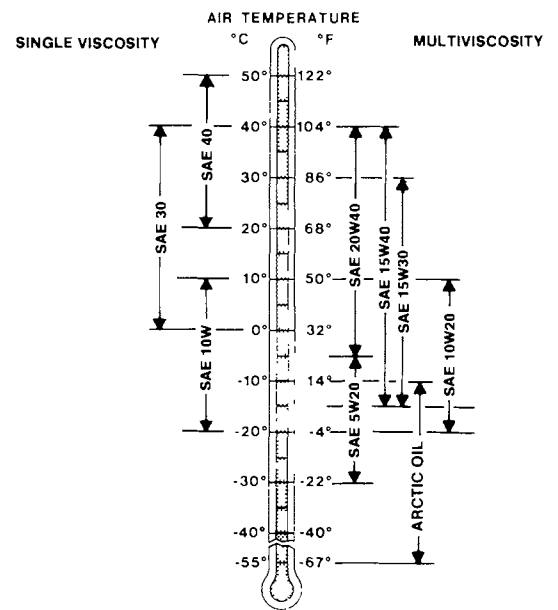

X9313/F1C/D/B/050783

ALTERNATIVE LUBRICANTS

Conditions in certain geographical areas may require special lubricants and lubrication practices which do not appear in this technical manual. If you have any questions, consult your John Deere dealer to obtain the latest information and recommendations.

F*O/D/C/050783

REMOVE ENGINE

Information for the Briggs & Stratton engine is in TM-1296 "Horizontal Crankshaft Small Engines." The following information is for removing the engine from the tiller.

 **CAUTION: Always disconnect spark plug cable (A) to prevent accidental starting.**

(Electric Start Only) Disconnect battery leads before working on engine.

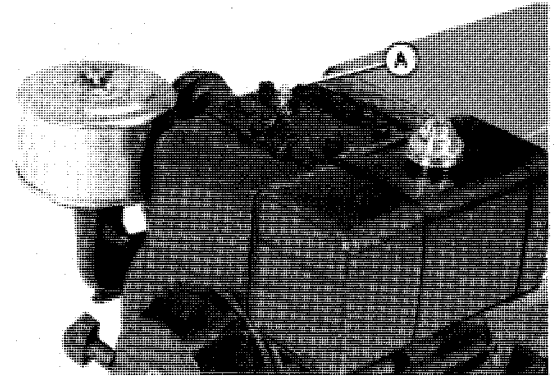

TY8558/F 10/E/A/050783

1. Loosen clamp (A) and remove throttle linkage (B).
2. (Electric Start Only) Disconnect ignition kill wire (C).
3. Remove nuts (D).
4. Remove sheave cover (E).

A—Clamp
B—Throttle Linkage
C—Ignition Kill Wire
D—Nuts
E—Sheave Cover

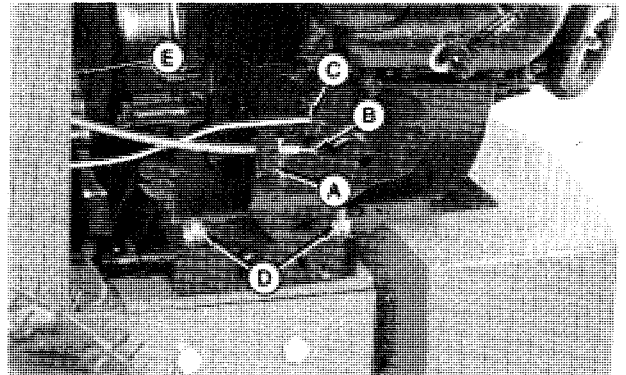

TY9818/F 10/E/B/050783

5. (Electric Start Only) Disconnect starter lead (A) and connector (B).
6. (Not Illustrated) Disconnect negative (-) battery cable from engine block.
7. Remove nuts (C) and lift engine off frame.

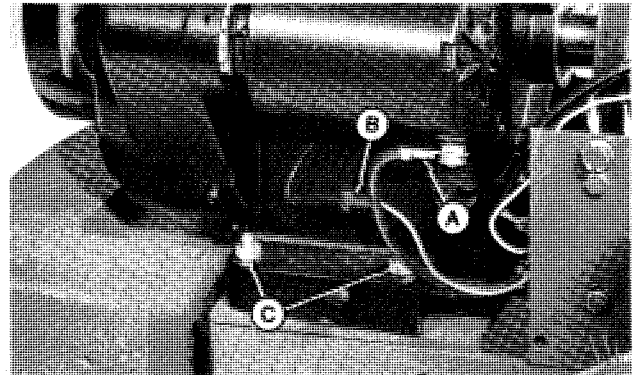

TY9819/F 10/E/C/050783

Section 20 POWER TRAIN

CONTENTS

	Page		Page
GROUP 05 - GENERAL INFORMATION		GROUP 20 - DRIVE SPROCKET, CHAIN AND AXLE	
Principle of Operation-Wheel Drive		Remove Drive Sprocket, Chain and Axle	20-20-01
Transmission	20-05-01	Inspect and Repair	20-20-02
Principle of Operation-Tine Reversing		Install Drive Sprocket, Chain and Axle	20-20-02
Transmission	20-05-01		
Diagnosing Malfunctions	20-05-02		
GROUP 10 - WHEEL DRIVE TRANSMISSION		GROUP 25 - DRIVE BELTS	
Specifications	20-10-01	Remove Wheel Drive Belt	20-25-01
Remove Sheave Cover	20-10-01	Remove Tine Drive Belt	20-25-01
Remove Battery and Box (Electric Start Only)	20-10-01	Remove Tine Drive Shaft	20-25-02
Remove Wheel Drive Transmission	20-10-02	Replace Tine Drive Sheave and Bearing	20-25-02
Disassemble Wheel Drive Transmission	20-10-03	Inspect and Repair	20-25-03
Inspect and Repair	20-10-05	Install Tine Drive Belt	20-25-03
Install Input Shaft	20-10-06	Install Wheel Drive Belt	20-25-04
Assemble Countershaft	20-10-07	Adjust Wheel Drive and Tine Drive Belts	20-25-04
Assemble Output Shaft	20-10-07		
Assemble Wheel Drive Transmission	20-10-08		
Adjust Shift Fork	20-10-09		
Install Wheel Drive Transmission	20-10-09		
GROUP 15 - TINE REVERSING TRANSMISSION			
Specifications	20-15-01		
Remove Tine Reversing Transmission	20-15-01		
Disassemble Tine Reversing Transmission	20-15-02		
Inspect and Repair	20-15-05		
Assemble Tine Reversing Transmission	20-15-06		
Install Tine Reversing Transmission	20-15-08		

PRINCIPLE OF OPERATION-WHEEL DRIVE TRANSMISSION

The 820 Rear Tine Tiller is equipped with a 4-forward speed and reverse gear transmission.

Gear shifting is done with a gear shift lever connected by linkage to the gear shift fork (A). The gears are lubricated by grease packed inside the case.

Bushings (B) are used on the ends of the output and countershaft.

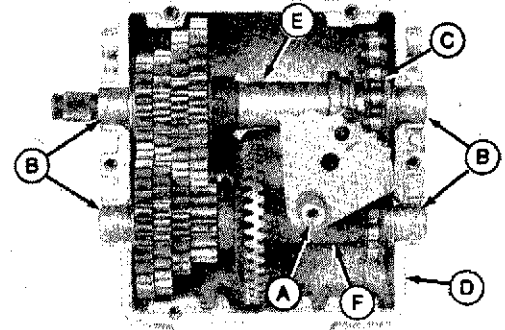

- A—Shift Fork
- B—Bushings
- C—Drive Chain
- D—Case
- E—Output Shaft
- F—Countershaft

TY9922/F20/A/A/050783

PRINCIPLE OF OPERATION-TINE REVERSING TRANSMISSION

The tine reversing transmission determines the rotation of the tine; either standard rotation or counter-rotation.

The input gear (A) turns the cluster gear (B) and reverser gear (C) which forces the output gear (D) to turn the tines in standard rotation.

When input gear (A) locks with output gear (B) the tines turn in a counter-rotating motion.

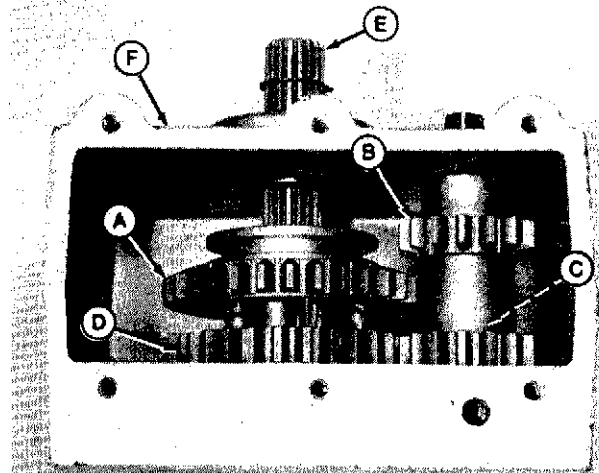

- A—Input Gear
- B—Cluster Gear
- C—Reverser Gear
- D—Output Gear
- E—Input Shaft
- F—Housing

TY9924/F20/A/B/050783

DIAGNOSING MALFUNCTIONS

Problem	Possible Cause	Correction	Reference
Drive Wheels Do Not Drive	Loose shifting linkage.	Tighten linkage.	—
	Improper belt adjustment.	Adjust belt.	20-25
	Broken belt.	Replace belt.	20-25
	Wheel pins missing or broken.	Replace pins.	—
	Broken drive chains.	Replace chains.	20-20
	Damaged drive sprockets.	Replace sprockets.	20-20
	Worn pulley key.	Replace key.	
	Damaged wheel drive transmission.	Remove, disassemble and inspect.	20-10
Hard Shifting (Wheel Drive Transmission)	Shifting when tiller is moving.	Shift only when tiller is stopped.	—
	Drive belt guide improperly installed.	Install properly.	20-25
	Shift linkage worn, bent or loose.	Repair or replace linkage.	—
	Lack of lubricant in transmission.	Fill to proper amount.	10-20
	Shift fork, shafts or gears damaged.	Remove, disassemble and inspect.	20-10
Tines Do Not Rotate	Improper belt adjustment.	Adjust belt.	20-25
	Tine clutch engagement dog loose.	Tighten dog set screw.	40-15
	Drive shaft coupler loose or damaged.	Repair or replace.	20-15
	Tine pins missing or broken.	Replace pins.	—
	Worm drive transmission damaged.	Remove, disassemble and inspect.	30-05
	Tine reversing transmission damaged.	Remove, disassemble and inspect.	20-15

SPECIFICATIONS

Item	Specification
Transmission Case Screws	10.2 to 12.4 N·m (90 to 110 lb-in.).
Mounting Cap Screws	17.7 N·m (156 lb-in.).

F20/B/A/050783

REMOVE SHEAVE COVER

Loosen two screws (A) on each side and lift sheave cover off unit.

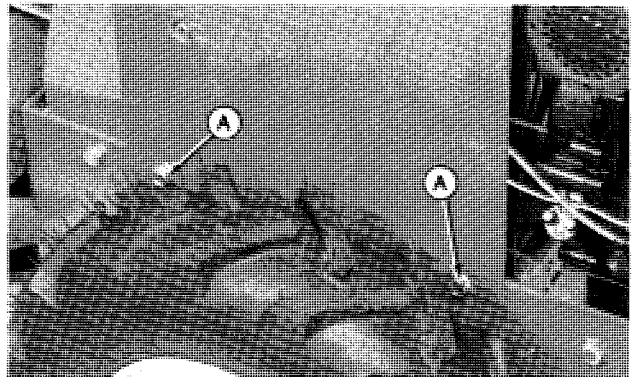

TY9820/F20/B/B/050783

**REMOVE BATTERY AND BOX
(Electric Start Only)**

1. Disconnect negative (-) cable (A).
2. Lift boot (B) and remove positive (+) cable.
3. Remove wing nuts (C), hold-down plate (D) and rods (E).
4. Remove battery from box.

A—Negative Cable	D—Hold-down Plate
B—Boot and Positive Cable	E—Rods
C—Wing Nuts	

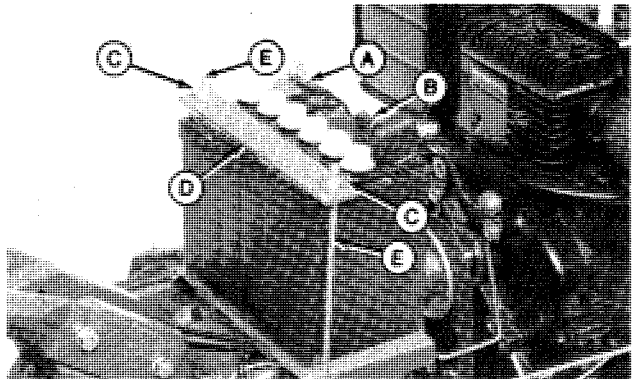

TY9821/F20/B/C/050783

5. Disconnect all wires from back of ignition switch (A).
6. Remove bolts (B) and lift box (C) off frame.

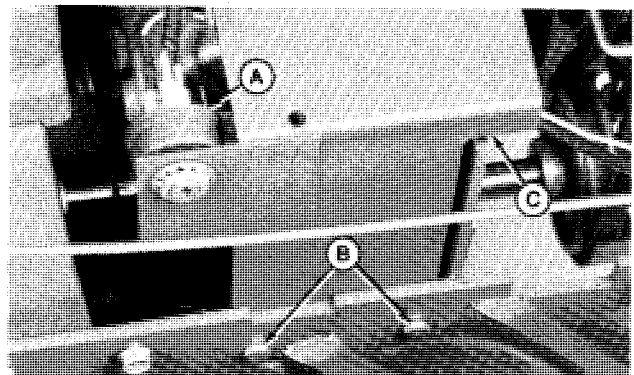

TY9822/F20/B/D/050783



Suggest:

If the above button click is invalid.

Please download this document

first, and then click the above link

to download the complete manual.

Thank you so much for reading

Wheel Drive Transmission

REMOVE WHEEL DRIVE TRANSMISSION

1. Place wooden block (A) under left side of frame so that tire is off the ground.
2. Pull pin (B) from axle and remove wheel.

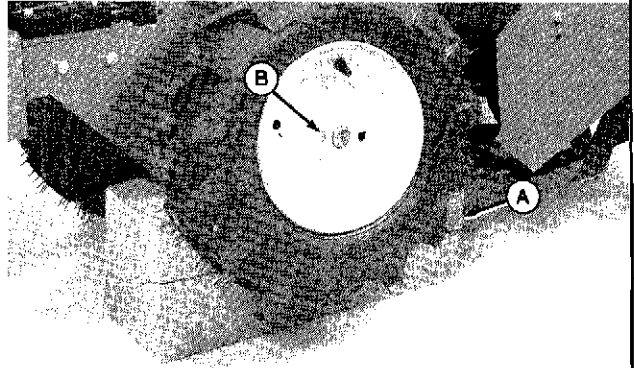

TY9823/F20/B/E/050783

3. Remove four cap screws (A) and lock nut (B).
4. Slide cover (C) off axle.

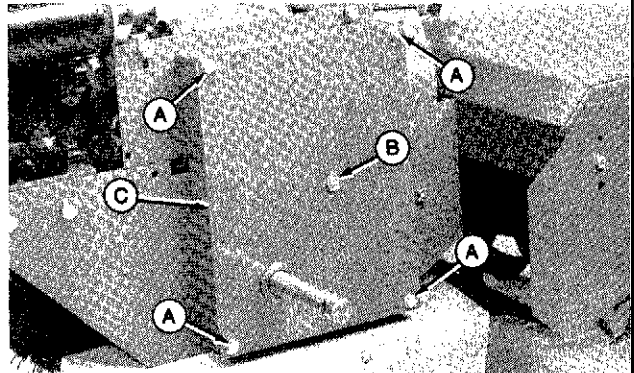

TY9824/F20/M/050783

5. Remove snap ring (A) and sprocket (B).

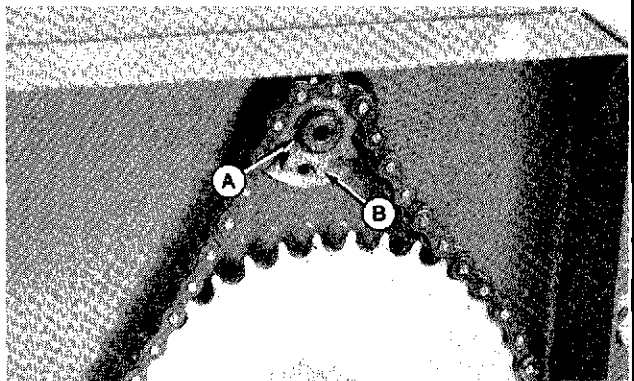

TY9825/F20/B/G/050783

6. Remove bolt and washer (A) and disconnect "U" bracket and linkage from transmission.

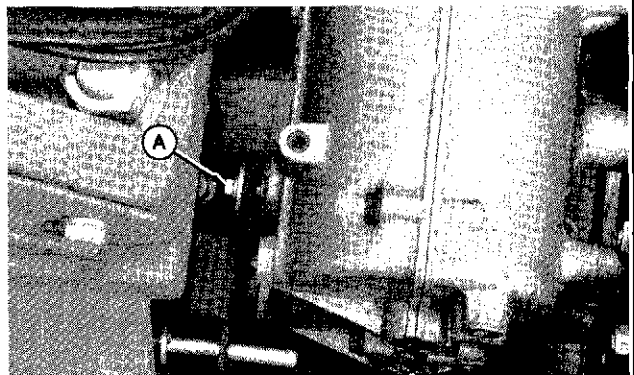

TY9826/F20/B/H/050783

<https://www.ebooklibonline.com>

Hello dear friend!

Thank you very much for reading.

Enter the link into your browser.

The full manual is available for immediate download.

<https://www.ebooklibonline.com>