

643
Feller-Buncher
Repair

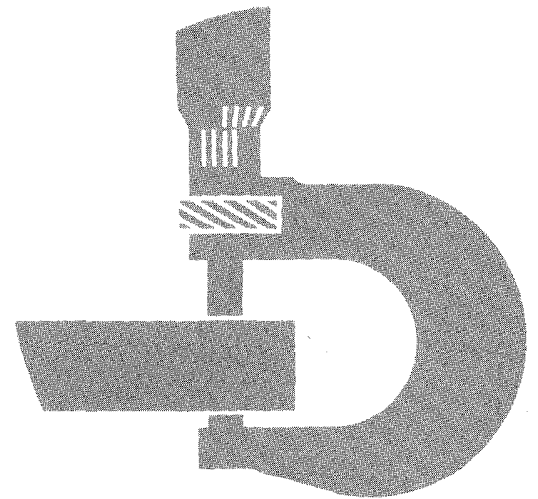

TECHNISCHES HANDBUCH

TM1425 (11JUN90)

Introduction

FOREWORD

This manual is written for an experienced technician. Essential tools required in performing certain service work are identified in this manual and are recommended for use.

Live with safety: Read the safety messages in the introduction of this manual and the cautions presented throughout the text of the manual.



This is the safety-alert symbol. When you see this symbol on the machine or in this manual, be alert to the potential for personal injury.

Technical manuals are divided in two parts: repair and diagnostics. Repair sections tell how to repair the components. Diagnostic sections help you identify the majority of routine failures quickly.

Information is organized in groups for the various components requiring service instruction. At the beginning of each group are summary listings of all applicable essential tools, service equipment and tools, other materials needed to do the job, service parts kits, specifications, wear tolerances, and torque values.

Binders, binder labels, and tab sets can be ordered by John Deere dealers direct from the John Deere Distribution Service Center.

This manual is part of a total product support program.

FOS MANUALS—REFERENCE

TECHNICAL MANUALS—MACHINE SERVICE

COMPONENT MANUALS—COMPONENT SERVICE

Fundamentals of Service (FOS) Manuals cover basic theory of operation, fundamentals of troubleshooting, general maintenance, and basic type of failures and their causes. FOS Manuals are for training new personnel and for reference by experienced technicians.

Technical Manuals are concise guides for specific machines. Technical manuals are on-the-job guides containing only the vital information needed for diagnosis, analysis, testing, and repair.

Component Technical Manuals are concise service guides for specific components. Component technical manuals are written as stand-alone manuals covering multiple machine applications.

Contents

SECTION I—GENERAL INFORMATION

- Group I—Safety
- Group II—General Specifications
- Group III—Torque Values
- Group IV—Lubrication
- Group V—Inspection Procedure

SECTION 01—WHEELS

- Group 0110—Power Wheels and Fastenings

SECTION 02—AXLES AND SUSPENSION SYSTEM

- Group 0200—Removal and Installation
- Group 0210—Differential or Bevel Drive
- Group 0225—Input Drive Shafts And U-Joints
- Group 0250—Axle Shaft, Bearings and Reduction Gears

SECTION 03—TRANSMISSIONS

- Group 0300—Removal and Installation
- Group 0315—Control Linkage
- Group 0350—Gear, Shafts, Bearings and Power Shift Clutch
- Group 0360—Hydraulic System

SECTION 04—ENGINE

- Group 0400—Removal And Installation

SECTION 05—ENGINE AUXILIARY SYSTEMS

- Group 0505—Cold Weather Starting Aids
- Group 0510—Cooling System
- Group 0515—Speed Controls
- Group 0520—Intake System
- Group 0560—External Fuel Supply System

SECTION 07—DAMPENER DRIVE

- Group 0752—Elements

SECTION 08—TRANSFER OR SPLITTER DRIVE (PUMP DRIVE GEARBOX)

- Group 0800—Removal And Installation

- Group 0851—Disassemble And Assemble Pump Drive Gearbox

SECTION 09—STEERING SYSTEM

- Group 0960—Hydraulic System

SECTION 10—SERVICE BRAKES

- Group 1011—Active Elements
- Group 1015—Controls Linkage
- Group 1060—Hydraulic System

SECTION 11—PARK BRAKE

- Group 1111—Active Elements
- Group 1115—Controls Linkage

SECTION 16—ELECTRICAL SYSTEM

- Group 1671—Batteries, Support and Cables
- Group 1672—Alternator, Regulator, and Charging System Wiring
- Group 1674—Wiring Harness and Switches
- Group 1676—Instruments and Indicators
- Group 1677—Motors and Actuators

SECTION 17—FRAME OR SUPPORTING STRUCTURE

- Group 1740—Frame Installation
- Group 1746—Frame Bottom Guards

SECTION 18—OPERATOR'S STATION

- Group 1800—Removal and Installation
- Group 1810—Operator Enclosure
- Group 1821—Seat and Seat Belt
- Group 1830—Heating and Air Conditioning

SECTION 20—SAFETY, CONVENIENCE AND MISCELLANEOUS

- Group 2003—Fire Extinguisher

SECTION 39—SHEAR

- Group 3901—Blades And Cutting Elements
- Group 3915—Controls Linkage
- Group 3960—Hydraulic System

Continued on next page

All information, illustrations and specifications in this manual are based on the latest information available at the time of publication. The right is reserved to make changes at any time without notice.

TM1425-19-11JUN90

COPYRIGHT® 1990
DEERE & COMPANY
Moline, Illinois
All rights reserved
A John Deere ILLUSTRATION™ Manual
Previous Editions
Copyright® 1988 Deere & Company

<https://www.ebooklibonline.com>

Hello dear friend!

Thank you very much for reading.

Enter the link into your browser.

The full manual is available for immediate download.

<https://www.ebooklibonline.com>

SECTION 99—DEALER FABRICATED TOOLS

Group 9900—Dealer Fabricated Tools

Section I
GENERAL INFORMATION

Contents

	Page
Group I—Safety	I-I-1
Group II—General Specifications	I-II-1
Group III—Torque Values	I-III-1
Group IV—Lubrication	I-IV-1
Group V—Inspection Procedure	I-V-1

HANDLE FLUIDS SAFELY—AVOID FIRES

When you work around fuel, do not smoke or work near heaters or other fire hazards.

Store flammable fluids away from fire hazards. Do not incinerate or puncture pressurized containers.

Make sure machine is clean of trash, grease, and debris.

Do not store oily rags; they can ignite and burn spontaneously.



O53,FLAME -19-26JAN90

TS227 -JUN-23AUG88

PREVENT BATTERY EXPLOSIONS

Keep sparks, lighted matches, and open flame away from the top of battery. Battery gas can explode.

Never check battery charge by placing a metal object across the posts. Use a volt-meter or hydrometer.

Do not charge a frozen battery; it may explode. Warm battery to 16°C (60°F).



O53,SPARKS -19-26JAN90

TS204 -JUN-23AUG88

HANDLE FUEL SAFELY—AVOID FIRES

Handle fuel with care: it is highly flammable. Do not refuel the machine while smoking or when near open flame or sparks.

Always stop engine before refueling machine. Fill fuel tank outdoors.

Prevent fires by keeping machine clean of accumulated trash, grease, and debris. Always clean up spilled fuel.



O53,FIRE1 -19-26JAN90

TS202 -JUN-23AUG88

PREVENT ACID BURNS

Sulfuric acid in battery electrolyte is poisonous. It is strong enough to burn skin, eat holes in clothing, and cause blindness if splashed into eyes.

Avoid the hazard by:

1. Filling batteries in a well-ventilated area.
2. Wearing eye protection and rubber gloves.
3. Avoiding breathing fumes when electrolyte is added.
4. Avoiding spilling or dripping electrolyte.
5. Use proper jump start procedure.

If you spill acid on yourself:

1. Flush your skin with water.
2. Apply baking soda or lime to help neutralize the acid.
3. Flush your eyes with water for 10—15 minutes. Get medical attention immediately.

If acid is swallowed:

1. Drink large amounts of water or milk.
2. Then drink milk of magnesia, beaten eggs, or vegetable oil.
3. Get medical attention immediately.

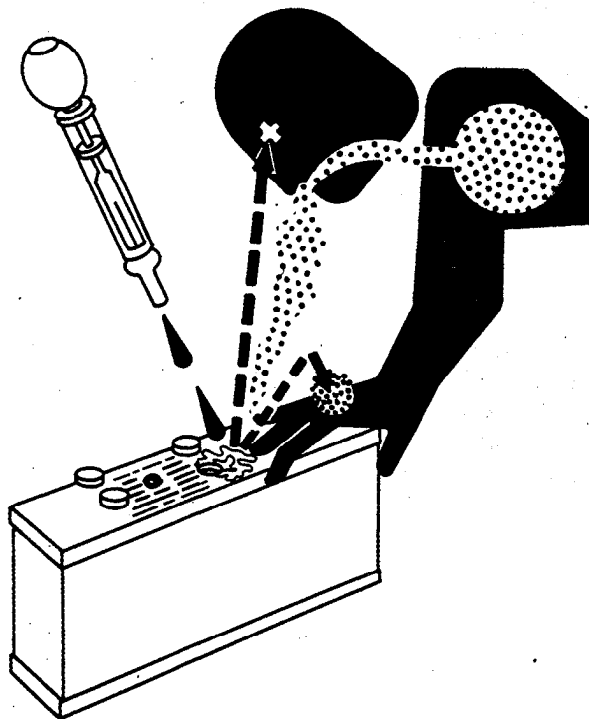

TS203 -UN-23AUG88

O53,POISON -19-26JAN90

AVOID HIGH-PRESSURE FLUIDS

Escaping fluid under pressure can penetrate the skin causing serious injury.

Avoid the hazard by relieving pressure before disconnecting hydraulic or other lines. Tighten all connections before applying pressure.

Search for leaks with a piece of cardboard. Protect hands and body from high pressure fluids.

If an accident occurs, see a doctor immediately. Any fluid injected into the skin must be surgically removed within a few hours or gangrene may result. Doctors unfamiliar with this type of injury may call the Deere & Company Medical Department in Moline, Illinois, or other knowledgeable medical source.

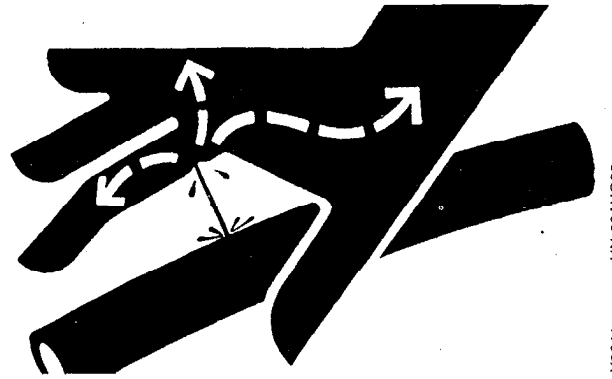

X9811
-JUN-23AUG88

O53,FLUID -19-26JAN90

SERVICE FELLER-BUNCHER SAFELY

Never operate the machine if an unsafe condition exists. Attach a "DO NOT OPERATE" tag to the steering wheel or disconnect the battery ground cable (—) before working on or under the machine.

Install the frame locking bar before working in the frame hinge pivot area.

Be sure you understand the service procedure before working on the machine.

Never lubricate or work on the machine while it is moving.

Always use two people when making checks with the engine running—the operator at the controls, able to see the person doing the checking.

Keep hands away from moving parts.

Disconnect battery ground cable (—) before welding on the machine or making adjustments on the engine or electrical system.

Place a support under all raised equipment. If a support is not available, lower equipment to the ground.

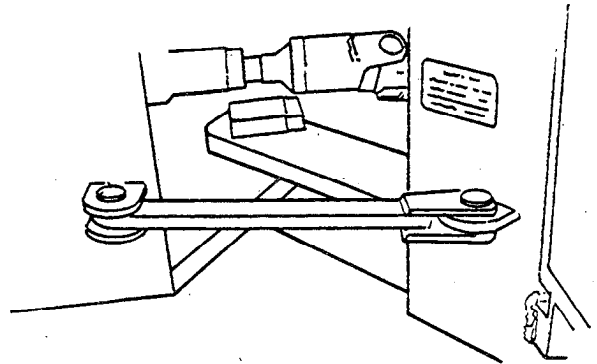

02T,05,J19 -19-28FEB90

-19-02JUN89

T6133AH

-UN-24MAY89

T6451BK

PARK MACHINE SAFELY

Before working on the machine:

- Lower all equipment to the ground.
- Stop the engine and remove the key.
- Disconnect the battery ground strap.
- Hang a "DO NOT OPERATE" tag in operator station.

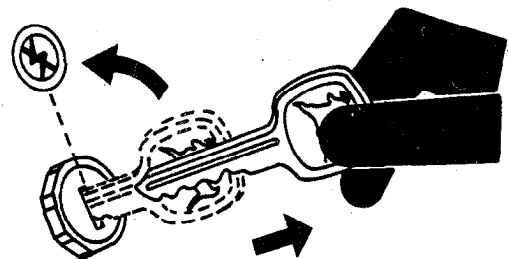

O53,PARK -19-26JAN90

-UN-24MAY89

TS230

SUPPORT MACHINE PROPERLY

Always lower the attachment or implement to the ground before you work on the machine. If you must work on a lifted machine or attachment, securely support the machine or attachment.

Do not support the machine on cinder blocks, hollow tiles, or props that may crumble under continuous load. Do not work under a machine that is supported solely by a jack. Follow recommended procedures in this manual.

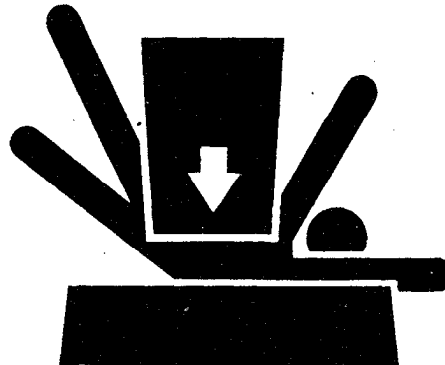

O53,LOWER -19-26JAN90

TS229 -UN-23AUG88

WEAR PROTECTIVE CLOTHING

Wear close fitting clothing and safety equipment appropriate to the job.

Prolonged exposure to loud noise can cause impairment or loss of hearing.

Wear a suitable hearing protective device such as earmuffs or earplugs to protect against objectionable or uncomfortable loud noises.

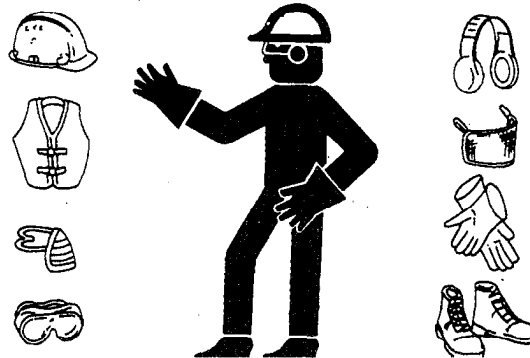

O53,WEAR -19-26JAN90

TS206 -UN-23AUG88

SERVICE MACHINES SAFELY

Tie long hair behind your head. Do not wear a necktie, scarf, loose clothing, or necklace when you work near machine tools or moving parts. If these items were to get caught, severe injury could result.

Remove rings and other jewelry to prevent electrical shorts and entanglement in moving parts.

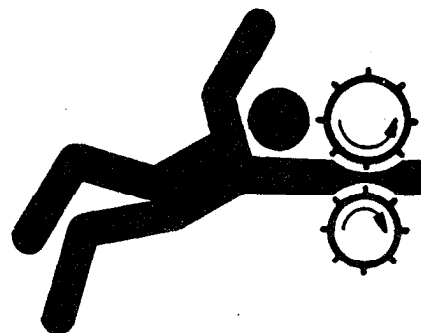

O53,LOOSE -19-26JAN90

TS228 -UN-23AUG88

WORK IN VENTILATED AREA

Engine exhaust fumes can cause sickness or death. If it is necessary to run an engine in an enclosed area, remove the exhaust fumes from the area with an exhaust pipe extension.

If you do not have an exhaust pipe extension, open the doors and get outside air into the area.

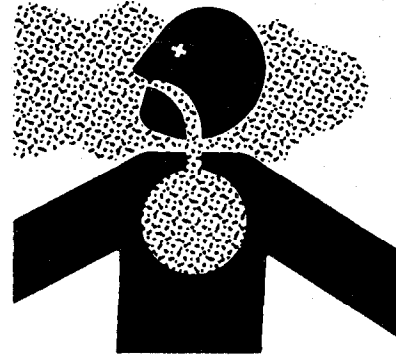

O53,AIR -19-26JAN90

TS220 -JUN-23AUG88

UNDERSTAND CORRECT SERVICE

Illuminate your work area adequately but safely. Use a portable safety light for working inside or under the machine. Make sure the bulb is enclosed by a wire cage. The hot filament of an accidentally broken bulb can ignite spilled fuel or oil.

Catch draining fuel, oil, or other fluids in suitable containers. Do not use food or beverage containers that may mislead someone into drinking from them. Wipe up spills at once.



O53,LIGHT -19-26JAN90

TS223 -JUN-23AUG88

REPLACE SAFETY SIGNS

Replace missing or damaged safety signs. See the machine operator's manual for correct safety sign placement.



O53,SIGNS1 -19-26JAN90

TS201 -JUN-23AUG88

SERVICE EQUIPMENT AND TOOLS

NOTE: Order tools from your SERVICE-GARD™ Catalog. Some tools may be available from a local supplier.

Name	Use
Hydraulic Floor Jack	To support bottom guards when removing or installing.
Shop Stands, 10 Ton, Approximately 660 mm (26 in.) high (two required)	To support front of unit when removing and installing front axle and differential.
Low Lift Transmission Jack	To remove and install front and rear differential and axle assemblies.
Shop Stands, 10 Ton, Approximately 1041 mm (41 in.) (two required)	To support rear of unit when removing and installing rear axle and differential.

0200,AA1 -19-28FEB90

SPECIFICATIONS

Item	Measurement	Specification
Front Bottom Guard	Weight (Approximate)	30 kg (65 lb)
Front Differential with Axle	Weight (Approximate)	726 kg (1600 lb)
Front Axle-to-Frame Mounting Cap Screws	Torque	1261 N·m (930 lb-ft)
Drive Line Universal Joint-to-Differential Yoke Cap Screws	Torque	61 N·m (45 lb-ft)
Axle Housing-to-Differential Cap Screws	Torque	244 N·m (180 lb-ft)
Front Differential Oil	Capacity	22.7 L (24 qt)
Rear Bottom Guard	Weight (Approximate)	48 kg (105 lb)
Rear Differential with Axle and Oscillating Support	Weight (Approximate)	771 kg (1700 lbs)
Rear Differential	End Play	0.00—0.457 mm (0.00—0.018 in.)

0200,AA2 -19-28FEB90

SPECIFICATIONS

Item	Measurement	Specification
Rear Axle Oscillating Rear Support-to-Frame Cap Screws	Torque	522 N·m (385 lb-ft)
Rear Axle Front Support-to-Frame Cap Screws	Torque	841 N·m (620 lb-ft)
Rear Differential Oil	Capacity	22.7 L (24 qt)

0200,AA3 -19-28FEB90

REMOVE AND INSTALL FRONT AXLE AND DIFFERENTIAL

1. Remove plug (A) to drain differential oil. Capacity is 22.7 L (24 qt). Install plug.

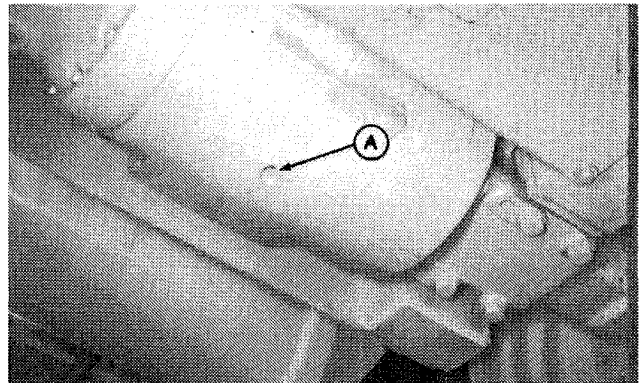

T6603BG
-UN-18OCT88

0200,AA4 -19-28FEB90

⚠ CAUTION: The approximate weight of front bottom guard is 30 kg (65 lb). Weight may increase significantly due to buildup of mud or debris.

2. Use floor jack (A) to remove front bottom guard (B).

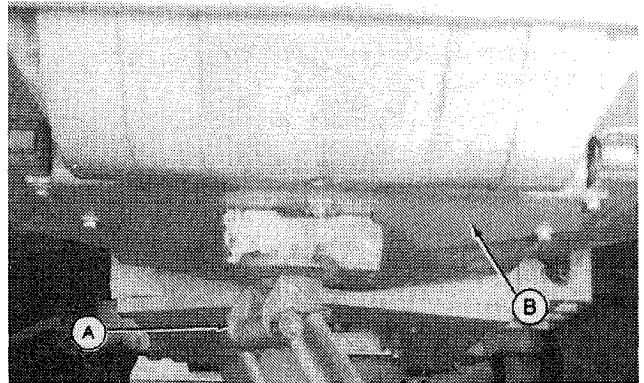

T6683VF
-UN-27OCT88

0200,AA5 -19-28FEB90

Removal and Installation/Front Axle and Differential

3. Raise front of unit and install stands (A) approximately 660 mm (26 in.) high directly behind axle on each side of frame. Lower unit onto stands.

4. Remove wheels. (See Group 0110.)

CAUTION: The approximate weight of the differential with axle is 726 kg (1600 lb).

5. Position a low lift transmission jack (B) under differential.

6. Secure jack mounting brackets (C) to axle.

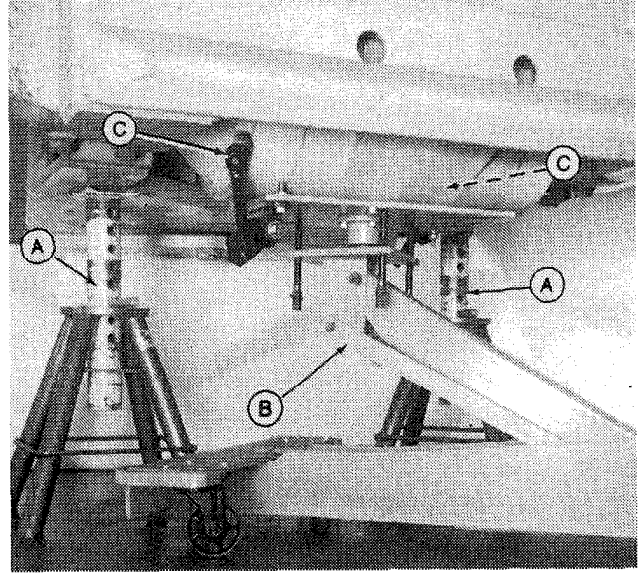

T6683VG -UN-27OCT88

0200,AA6 -19-28FEB90

7. Disconnect brake line (A). Cap and plug openings.

8. Remove drive line universal joint (B) from yoke (C).

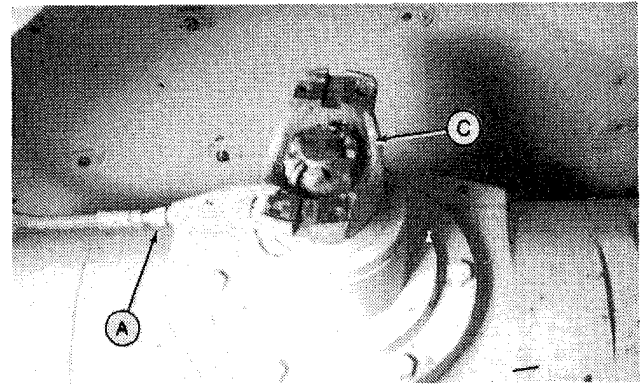

T6683VH -UN-27OCT88

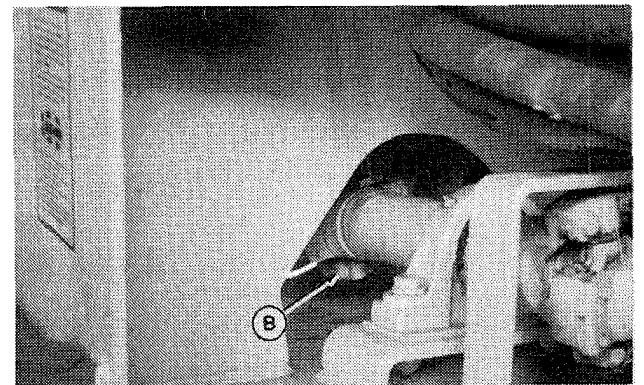

T6683VJ -UN-27OCT88

0200,AA7 -19-28FEB90

Removal and Installation/Rear Axle Differential

9. Remove mounting cap screws and lock nuts (A).
10. Carefully lower jack to remove axle and differential from frame.
11. Repair or replace parts as necessary. (See Group 0210.)

TORQUE SPECIFICATIONS

Axle and Differential Mounting	
Cap Screws	1261 N·m (930 lb-ft)
Drive Line Universal Joint-to-Yoke	
Cap Screws	61 N·m (45 lb-ft)
Axle-to-Differential Case	
Cap Screws	244 N·m (180 lb-ft)

12. Fill differential with oil. (See Section I, Group IV.)
13. Bleed brakes. (See Group 1060.)

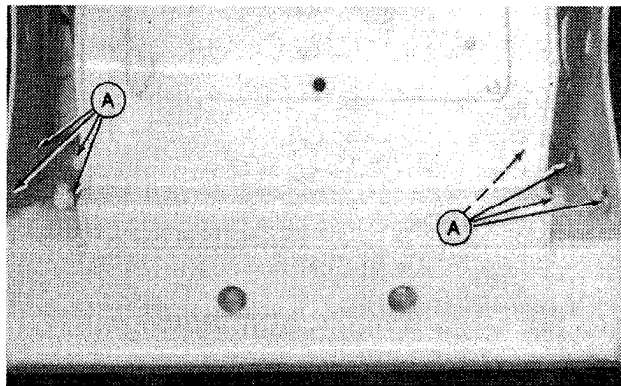

T6683VI -JN-27OCT88

0200,AA8 -19-28FEB90

REMOVE REAR AXLE AND DIFFERENTIAL

1. Remove plug (A) to drain differential oil. Capacity is 22.7 L (24 qt). Install plug.

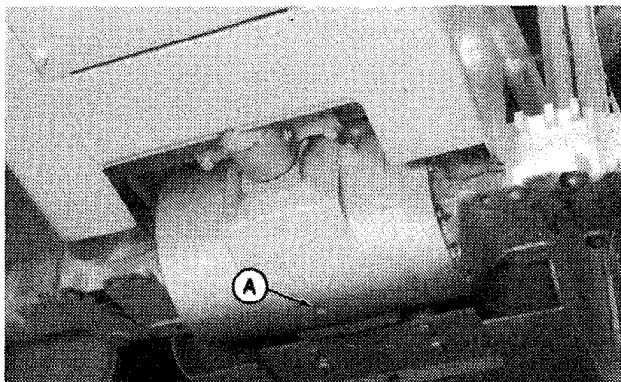

T6598BR1 -JN-18OCT88

0200,AA10 -19-28FEB90

CAUTION: The approximate weight of rear bottom guard is 48 kg (105 lb). Weight may increase significantly due to buildup of mud or debris.

2. Use floor jack to remove rear bottom guard (A). Bottom guard is hinged at end (B).

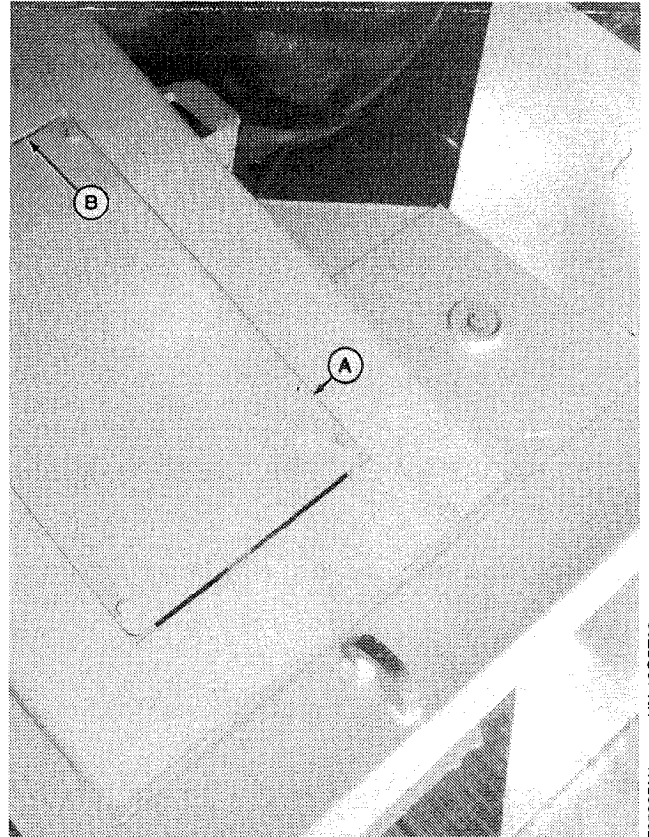

0200,AA11 -19-28FEB90

T6598BN1 -JUN-18OCT88

3. Raise rear of unit and install stands (A) under the hydraulic reservoir and fuel tank. (Stands must be approximately 1041 mm [41 in.] high.) Lower unit onto stands.

4. Remove wheels. (See Group 0110.)

CAUTION: The approximate weight of differential with axle and oscillating supports is 771 kg (1700 lb).

5. Position a low lift transmission jack (B) under differential and secure axle to jack mounting brackets.

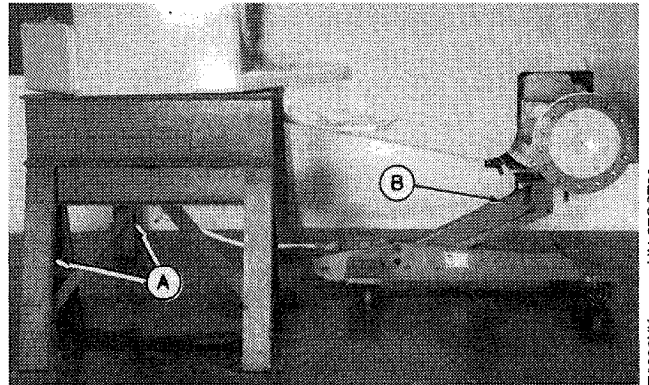

0200,AA12 -19-28FEB90

T6683VK -JUN-27OCT88

Removal and Installation/Rear Axle Differential

6. Disconnect brake line (A).

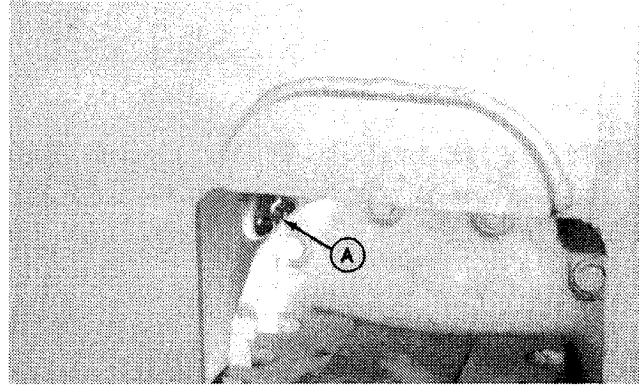

0200,AA13 -19-28FEB90

T6683VL -JUN-27OCT88

7. Remove rear oscillating lubrication line (A) and fitting from oscillating pin (B).

8. Remove four cap screws to disconnect support from frame.

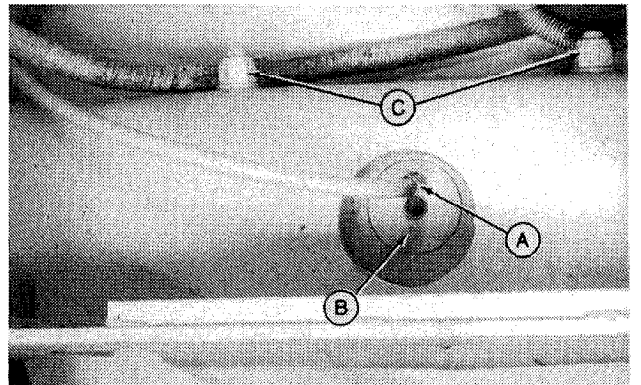

0200,AA14 -19-25MAY90

T6683VM -JUN-27OCT88

9. Remove drive line universal joint from yoke (A).

10. Remove lubrication line (B).

11. Support bottom guard plate (C) and remove cap screws (D).

12. Carefully lower jack to remove axle and differential from frame.

13. Repair or replace parts as necessary. (See Group 0210.)

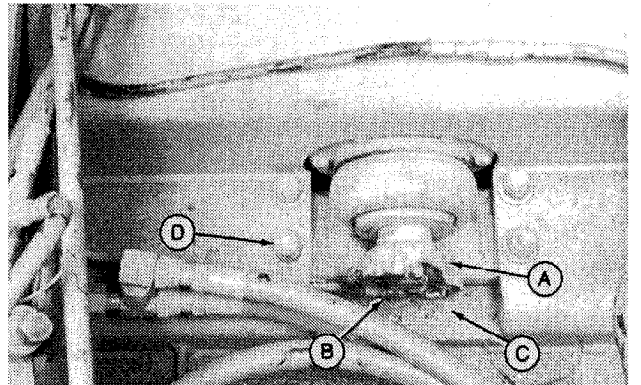

A—Yoke
B—Lubrication Line
C—Bottom Guard Plate
D—Cap Screw

0200,AA15 -19-25MAY90

T6683VN -JUN-27OCT88

INSTALL REAR AXLE AND DIFFERENTIAL

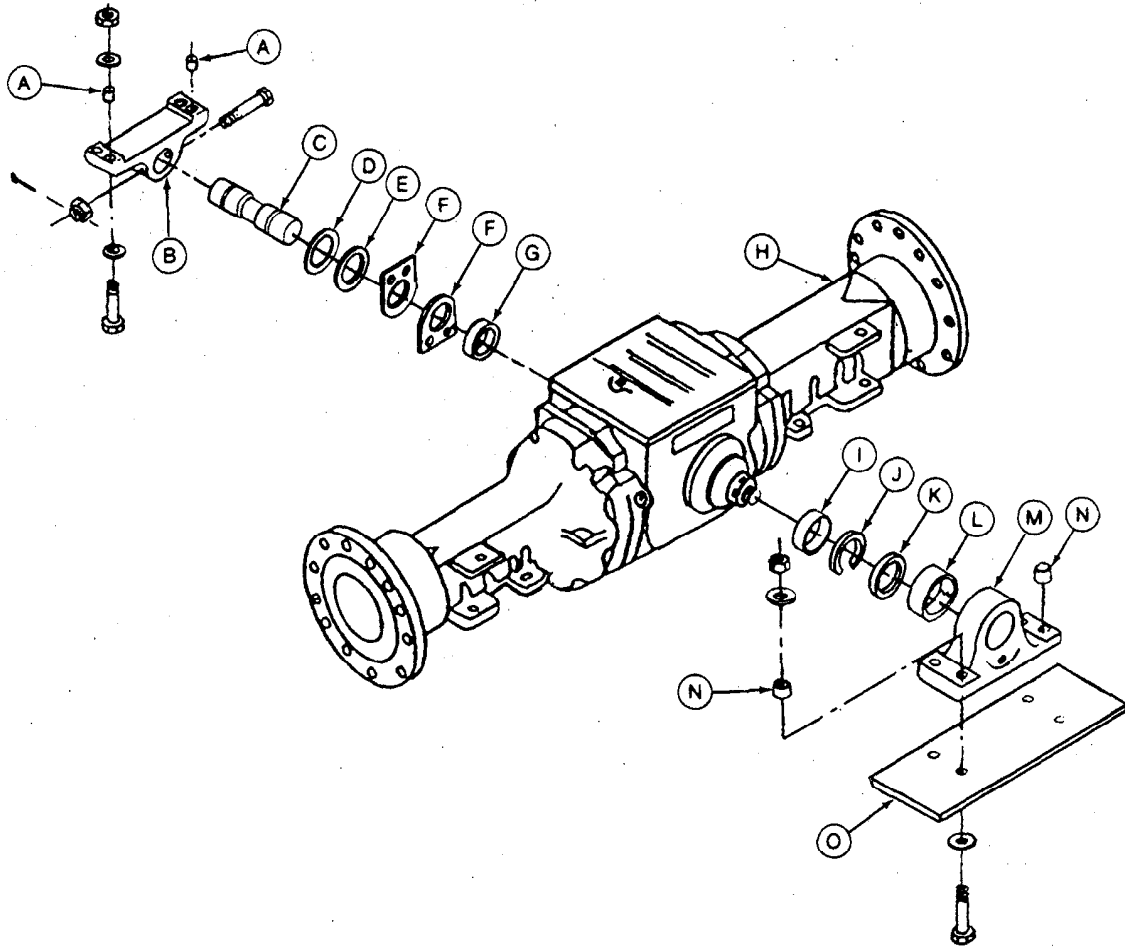

A—Dowel (2 used)
 B—Oscillating Differential
 Rear Support
 C—Oscillating Pin

D—Shim (as required)
 E—Washer (2 used)
 F—Thrust Plate (2 used)
 G—Seal

H—Rear Axle and Differential
 I—Bushing
 J—Snap Ring
 K—Thrust Washer

L—Bushing
 M—Front Support
 N—Dowel (2 used)
 O—Bottom Guard Plate

When installing rear axle and differential, differential end play must be adjusted.

1. Raise rear axle and differential (H) with oscillating support components (A—G and I—O) installed.
2. Secure supports (B and M) to frame using two sets of hardware in each support. Dowels must be

positioned in front holes of front support. Tighten cap screws slightly.

3. Move differential forward as far as possible using a prybar.

4. If a gap exists between oscillating differential rear support (D) and special washer and shims (E), measure this end play using a feeler gauge.

5. End play specification is 0.00—0.457 mm (0.00—0.018 in.). Adjust end play by adding or deducting shims between support and first thrust plate (F).

6. After adjusting, axle must oscillate freely by hand.

- | | |
|--|---|
| A—Lubrication Line Fitting | F—Rear Thrust Plate |
| B—O-ring (2 used) | G—Front Thrust Plate |
| C—Oscillating Pin | H—Differential Housing |
| D—Oscillating Differential Rear Support | I—Grease Seal |
| E—Special Washer and Shims (as required) | J—0.00—0.457 mm (0.00—0.018 in.) End Play |

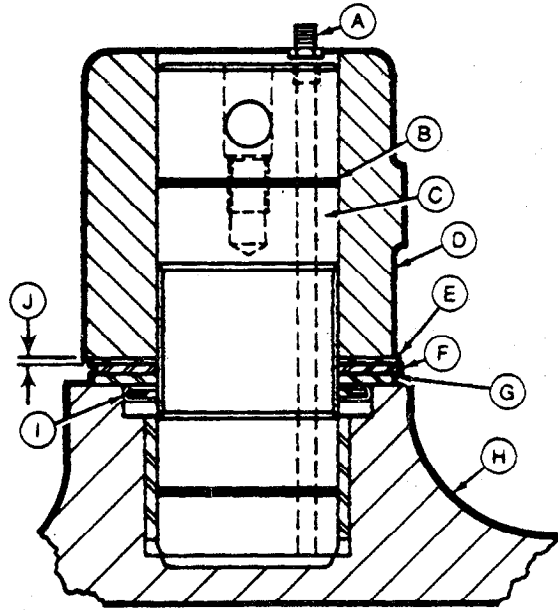

0200,AA17 -19-28FEB90

T6663VP -UN-27OCT88

7. Install front lubrication line.

8. Install remaining sets of hardware in front and rear supports. Tighten rear support first.

TORQUE SPECIFICATIONS

Oscillating Differential Rear Support	
Cap Screws	522 N·m (385 lb-ft)
Front Support Cap Screws	841 N·m (620 lb-ft)

9. Install rear lubrication line and brake line.

TORQUE SPECIFICATIONS

Universal Joint-to-Differential	
Yoke Cap Screws	61 N·m (45 lb-ft)
Axle-to-Differential	
Cap Screws	244 N·m (180 lb-ft)

10. Fill differential with oil. (See Section I, Group IV.)

11. Bleed brakes. (See Group 1060.)

0200,AA18 -19-28FEB90

SERVICE EQUIPMENT AND TOOLS

NOTE: Order tools from your SERVICE-GARD™ Catalog. Some tools may be available from a local supplier.

Name	Use
Puller	To remove bearings.
Knife Edge Puller	To remove bearings.
D-01045AA Bushing, Bearing, and Seal Driver Set	To remove and install bushings and bearing cups.

R50,50300,1995 -19-28FEB90

OTHER MATERIAL

Number	Name	Use
AT38226 (3M No. 2158)	Epoxy	To install ring gear cap screws.
T43514	Plastic Gasket	To seal input shaft seal.
TY6305	Clean and Cure Primer	To prime surfaces where T43514 Plastic Gasket is used.

R50,50300,1996 -19-28FEB90

DIFFERENTIAL SPECIFICATIONS

Item	Measurement	Specification
Differential Carrier Bearings	Preload	0.05—0.10 mm (0.002—0.004 in.)
	Rolling Drag Torque	9—35 N (2.1—7.8 lb force)
Differential Drive Shaft	End Play	0.025—0.075 mm (0.001—0.003 in.)
	Backlash	0.19—0.39 mm (0.007—0.015 in.)
Differential Housing		
Cover Cap Screws	Torque	115 N·m (85 lb-ft)
Differential Quill Cap Screws	Torque	115 N·m (85 lb-ft)
Differential Drive Shaft Quill Cap Screws	Torque	50 N·m (37 lb-ft) plus 90 degrees (1/4 turn)
Differential Case Cover	Torque	75 N·m (55 lb-ft)
Ring Gear Cap Screws	Torque	149 N·m (110 lb-ft)

R50,50300,1997 -19-28FEB90

REMOVE DIFFERENTIAL INPUT QUILL AND SHAFT

⚠ CAUTION: The approximate weight of the input quill and shaft assembly is 25 kg (55 lb).

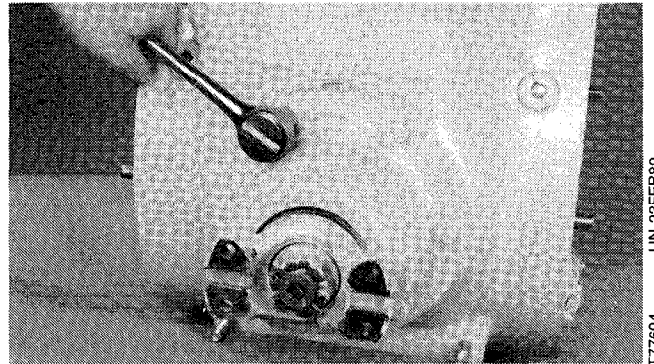

T77604 -JUN-23FEB89

R50,50300,2071 -19-28FEB90



Suggest:

If the above button click is invalid.

Please download this document

first, and then click the above link

to download the complete manual.

Thank you so much for reading

DISASSEMBLE INPUT QUILL AND SHAFT ASSEMBLY

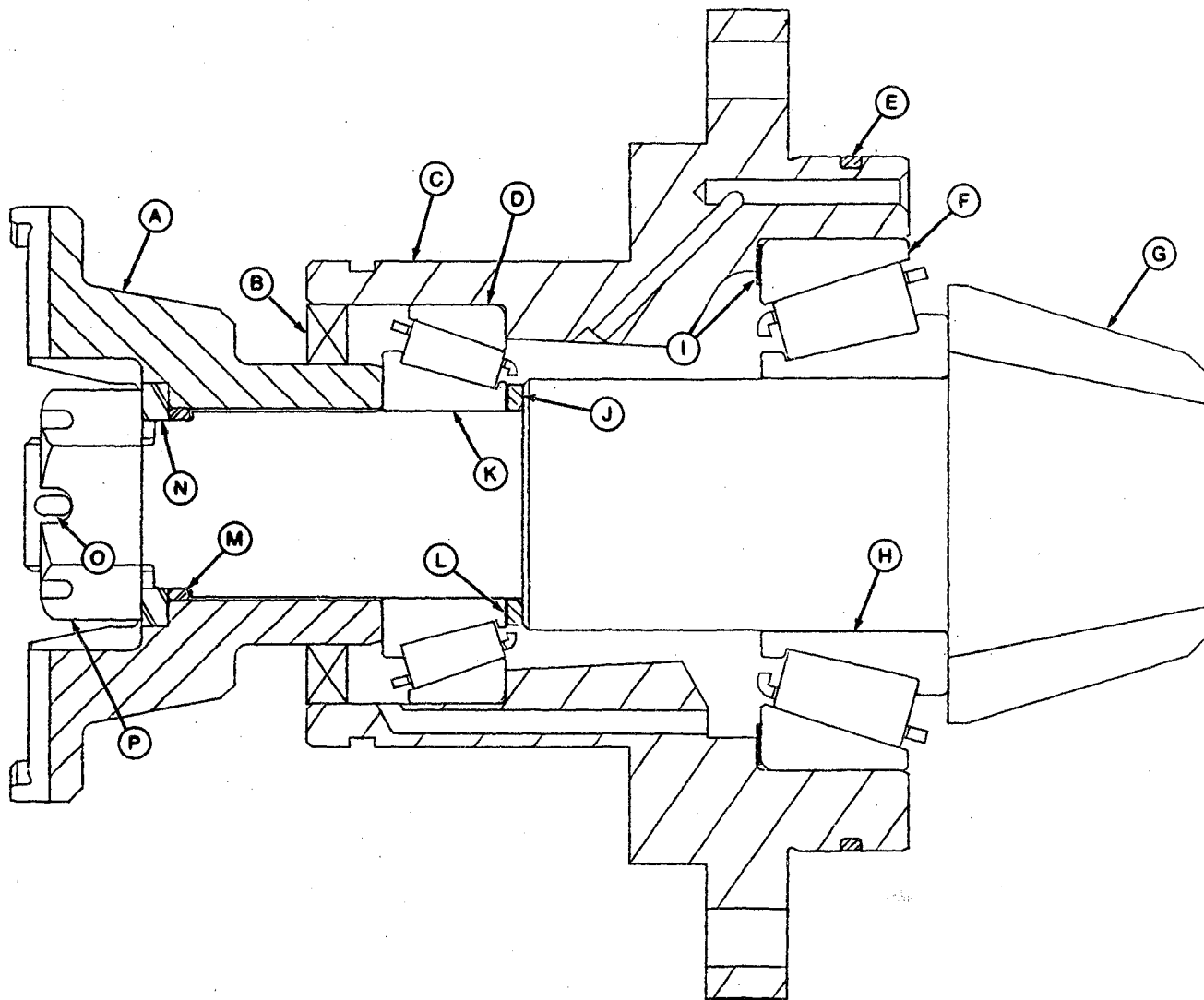

A—Yoke
 B—Oil Seal
 C—Input Quill
 D—Bearing Cup
 E—O-ring

F—Bearing Cup
 G—Bevel Pinion Shaft
 H—Bearing Cone
 I—Shim (use as required)

J—Spacer
 K—Bearing Cone
 L—Shims (use as required)
 M—O-ring

N—Special Washer (use as required)
 O—Cotter Pin
 P—Slotted Nut

R40141 -JUN-03/JAN89

R50,50300,2072 -19-28FEB90

<https://www.ebooklibonline.com>

Hello dear friend!

Thank you very much for reading.

Enter the link into your browser.

The full manual is available for immediate download.

<https://www.ebooklibonline.com>