



488 Rotary Tiller



JOHN DEERE

TECHNICAL MANUAL

488
Rotary Tiller

TM1252 (01MAY81) English

John Deere Horicon Works
TM1252 (01MAY81)

LITHO IN U.S.A.
ENGLISH



CONTENTS

Introduction	05
Description	05-2
Specifications	05-3
Rotary Tiller Serial Number	05-3
Gear Case Serial Number	05-4
Torque Charts	05-5
Lubrication	10
Lubricate Gear Case	10-1
Gear Case Oil	10-1
Grease Fittings	10-2
Adjustments	20
Level Tiller Side-to-Side	20-1
Level Tiller Front-to-Rear	20-1
Adjust Sway Chains	20-2
Adjust Drive Chain	20-2
Diagnose Malfunctions	30
Tine Shaft Does Not Rotate	30-1
Erratic Tiller Operation	30-1
Tiller Does Not Till Effectively	30-1
Replace Tines and Drive Components	40
Replace Tines	40-1
Replace Left-Hand Tine Shaft Bearing	40-1
Replace Right-Hand Tine Shaft Bearing	40-2
Repair or Replace Drive Chain	40-2
Replace Shear Bolt	40-3
Service Gear Case	50
Remove Gear Case	50-1
Disassemble Gear Case	50-1
Inspect Gear Case Parts	50-4
Assemble Gear Case	50-5
Install Gear Case	50-8
Service Powershaft	60
Remove Powershaft	60-1
Disassemble Powershaft	60-1
Install Powershaft	60-3

INTRODUCTION

This technical manual contains service and maintenance information for the John Deere 448 Rotary Tiller.

Basic service information pertaining to removal, disassembly, inspection and repair is given in detail. Emphasis is placed on diagnosing malfunctions for quick reference in determining the cause of machine failure.



This safety alert symbol identifies important safety messages. When you see this symbol, be alert to the possibility of personal injury and carefully read the message that follows.

Metric equivalents have been included where applicable throughout this technical manual.

0A7; M19/05 B 230481

DESCRIPTION

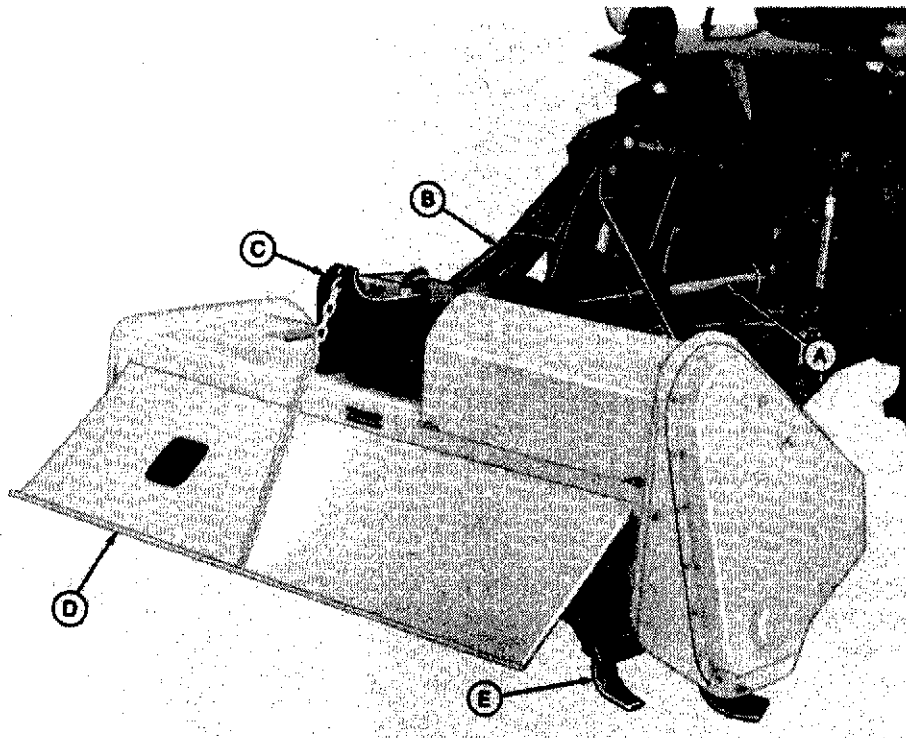

A—Powershaft
B—Hitch Mast

C—Gear Case
D—Leveler Blade

E—Tines

The 448 Rotary Tiller is a heavy-duty integral rotary tiller for use with John Deere Model 650 and 750 Tractors. The rotary Tiller is mounted on the 3-point hitch of the tractor and driven by the rear PTO shaft.

NOTE: The 448 Rotary Tiller may be used on competitive tractors with up to 20 horsepower that are equipped with a category 1 3-point hitch and a 540 RPM PTO.

The powershaft (A) is connected to the tractor PTO shaft and rotary tiller gear case (C).

A pinion and bevel gear is connected to a drive shaft inside the gear case. The gear case drive shaft is connected to a countershaft with a shear bolt. The bolt will shear if the tiller tines strike a solid obstruction. A sprocket and chain drive connected to the countershaft rotates the tines.

0A7; M28266 M19/05 C 290481

<https://www.ebooklibonline.com>

Hello dear friend!

Thank you very much for reading.

Enter the link into your browser.

The full manual is available for immediate download.

<https://www.ebooklibonline.com>

SPECIFICATIONS

Tractor Required* John Deere Model 650 and 750

*The Model 448 Rotary Tiller may be used on competitive tractors up to 20 horsepower equipped with a category 1 3-point hitch and a 540 RPM PTO.

Width of Cut (122 cm) 48 Inches

Rotor Diameter (406 mm) 16 Inches

Rotor Bearings . . . (31.8 mm) 1-1/4 Inches Self-Aligning Ball Bearings with Wide Inner Race and Land Riding Seals (Triple Lip)

Gear Case Right Angle Curtis Model 412 with Forged Gears

Tines Heat Treated High-Carbon Steel

Drive U-Joint Shaft From Tractor PTO to Right Angle Gear Case

Shear Protection Countershaft Shear Bolt

Rotor RPM 185

Tip Speed (235.7 M/min.) 773 Feet Per Minute

Height of Lift (381 mm) 15 Inches

Overall Width (135 cm) 53 Inches

Net Weight (113.6 kg) 250 Lbs.

(Specifications and design subject to change without notice.)

0A7; M19/05 D 240481

ROTARY TILLER SERIAL NUMBER

The rotary tiller serial number is located on the rear housing below the gear case.

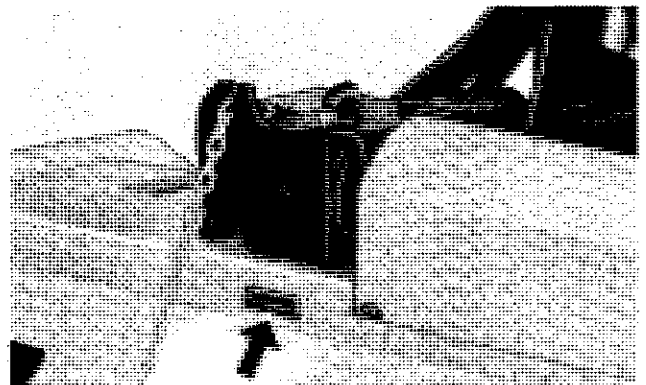

0A7; M28267 M19/05 E 240481

GEAR CASE SERIAL NUMBER

The gear case serial number is located on a plate attached to the gear case.

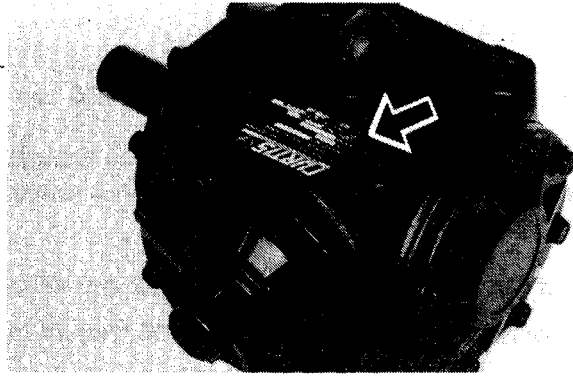

0A7;M26302 M19;05 F 240481

BOLT TORQUE CHARTS**Bolt Torque Chart****AVERAGE TIGHTENING TORQUE FOR BOLTS
(BASED ON 85% OF YIELD)**

BOLT SIZE	A17B			A17D			A17F		
	lb-in	lb-ft	N-m	lb-in	lb-ft	N-m	lb-in	lb-ft	N-m
1/4	72	6	8	120	10	13.5	168	14	19
5/16	156	13	17.6	240	20	27	360	30	40.7
3/8	276	23	31.2	420	35	47.5	600	50	67.8
7/16	420	35	47.5	660	55	74.6	960	80	108.5
1/2	660	55	74.6	1020	85	115.2	1440	120	162.7
9/16	900	75	101.7	1560	130	176.3	2100	175	237.3
5/8	1260	105	142.4	2040	170	230.5	2880	240	325.4
3/4	2220	185	250.8	3600	300	406.7	5100	425	576.2
7/8	1920	160	216.9	5340	445	603.3	8220	685	928.7
1	3000	250	339	8040	670	908.4	12360	1030	1396.5
1-1/8	3960	330	447.4	10920	910	1233.8	17520	1460	1979.5
1-1/4	5760	480	650.8	15000	1250	1694.8	24720	2060	2793

B grade bolts larger than 3/4 are sometimes formed hot rather than cold, which accounts for the lower mean tightening torque.

Set Screw Seating Torque Chart

Screw Size	Seating Torque	
	Inch-Pounds	Newton Meters (N-m)
#5	9	1.0
#6	9	1.0
#8	20	2.3
#10	33	3.7
1/4	87	9.8
5/16	165	18.6
3/8	290	32.8
7/16	430	48.6
1/2	620	70.1
9/16	620	70.1
5/8	1225	138.4
3/4	2125	240.1

LUBRICATE GEAR CASE

Level rotary tiller gear case with surface. Remove gear case check plug (A). Lubricant should be level with check plug hole. If necessary, add lubricant specified in chart below.

IMPORTANT: Check vent (B) to be sure it is open. If vent is closed, oil will be forced out of seals causing gear case to leak.

A—Check Plug
B—Vent

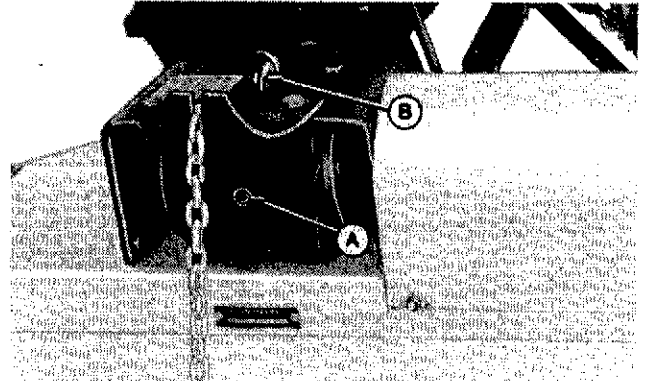

0A7:M55268 M19/10 B 240481

GEAR CASE OIL

John Deere API GL-5 Gear Oil is recommended. If other oils are used, they must meet performance requirements of:

- API Service Classification
GL-5
- Military Specification
MIL-L-2105C

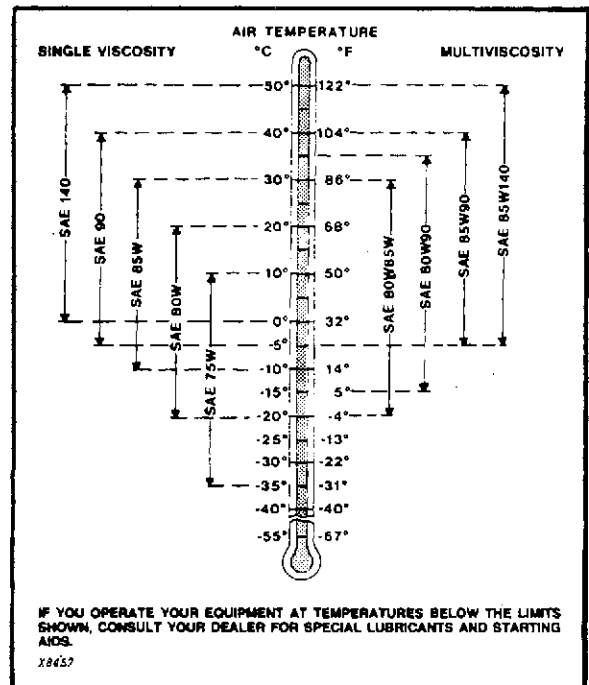

0A7:X8457 M19/10 C 240481

GREASE FITTINGS

John Deere Multipurpose Grease is recommended in all grease fittings at hourly intervals given. If other greases are used, they must meet these specifications:

- SAE Multipurpose Grease
- SAE Multipurpose Grease containing 3 to 5 percent molybdenum disulfide.

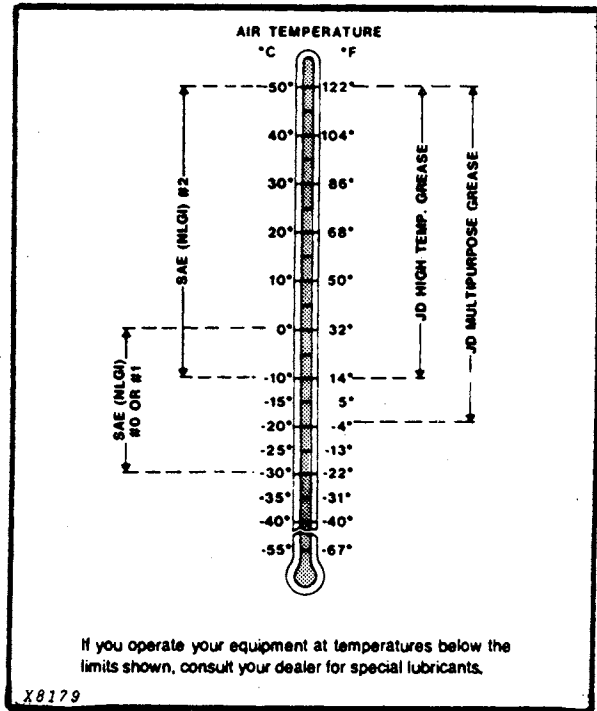

0A7;X8179 M19;10 D 240481

Lubricate two grease fittings on powershaft every 25 hours of operation with a hand-type grease gun.

IMPORTANT: Only one or two strokes from the grease gun are sufficient. If fittings are over-lubricated, seals will be damaged and dirt will enter bearings.

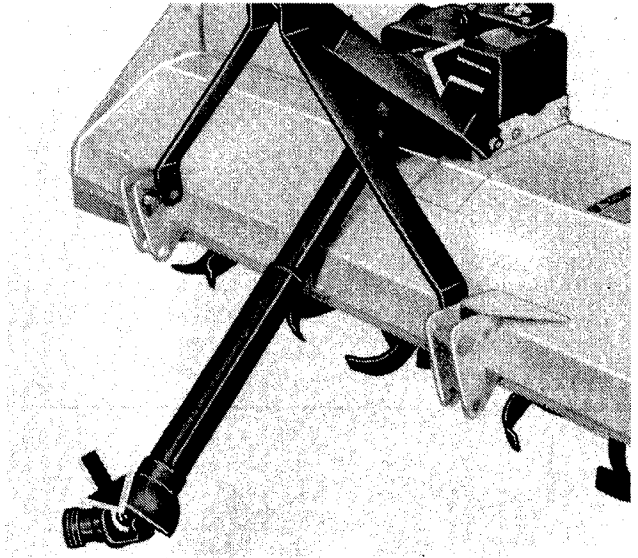

0A7;M28269 M19;10 E 240481

Lubrication

Use multipurpose grease shown in chart whenever drive chain housing is disassembled. Pack lower part of shield with approximately (0.68 kg) 1-1/2 pounds of grease.

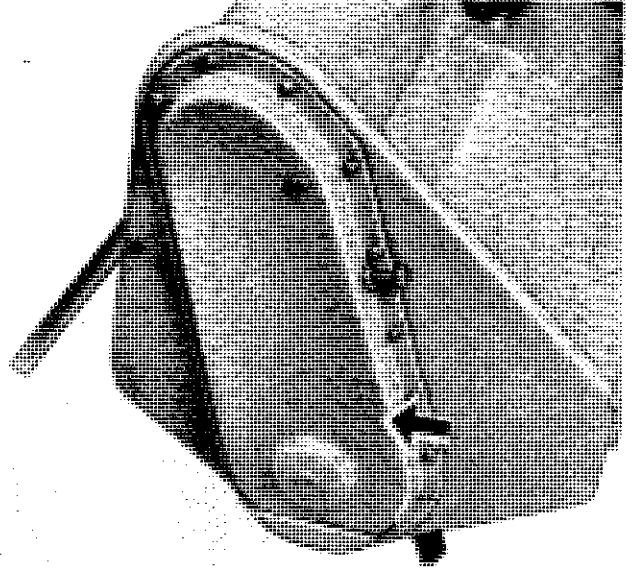

DA7/M28270 M19/30 F 240481

LEVEL TILLER SIDE-TO-SIDE

Start tractor engine and raise tiller to maximum height. Stop tractor engine and set parking brake.

IMPORTANT: Adjustment must be made on a level surface such as a cement shop floor.

Lengthen or shorten adjustable right-hand draft link until there is equal clearance between outside tine and surface on both sides.

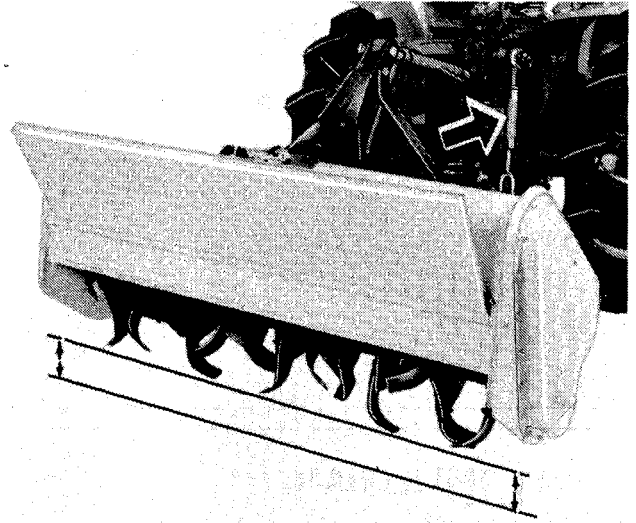

0A7;M28271 M19;20 A 240481

LEVEL TILLER FRONT-TO-REAR

1. Lower tiller until tines are (6.35 mm) 1/4-inch off surface.
2. Place a level across top of tiller housing. Loosen center link lock nut and adjust center link until tiller housing is level with surface.
3. Tighten lock nut on center link.

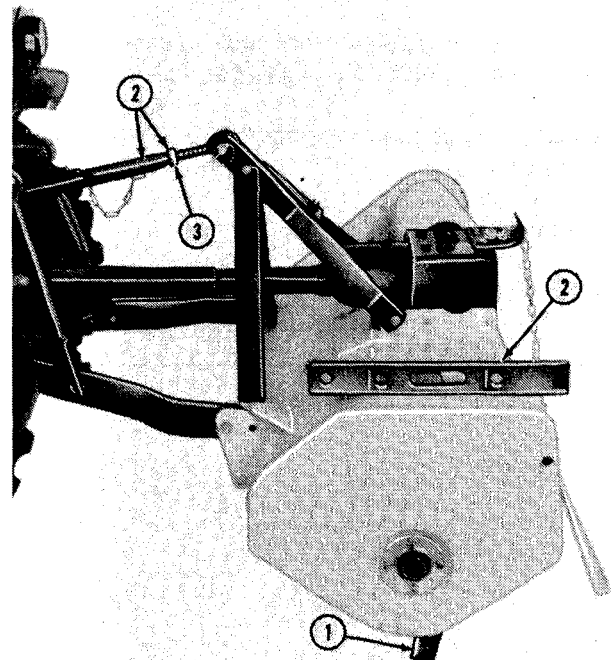

0A7;M28272 M19;20 B 240481



Suggest:

If the above button click is invalid.

Please download this document

first, and then click the above link

to download the complete manual.

Thank you so much for reading

ADJUST SWAY CHAINS

Adjust turnbuckles on sway chains to eliminate slack.

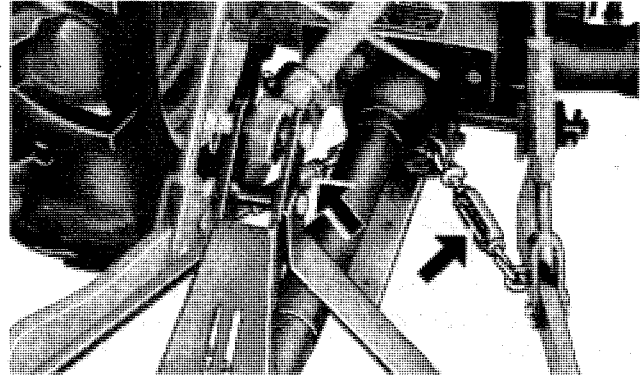

0A7/M28273 M19/20 C 240481

ADJUST DRIVE CHAIN

1. Start tractor engine and raise tiller. Stop engine and set parking brake.



CAUTION: Remove tractor ignition key. Place wood blocks or stands under tiller housing to keep it in the raised position.

2. Loosen jam nut.
3. Turn screw in until a slight drag is felt.
4. Move tiller tines back and forth until chain slack (backlash) is felt.
5. Continue turning screw while moving tiller tines until no backlash can be felt and a slight drag exists on chain.
6. Back screw out approximately 1/2 turn or until tiller tines turn freely.
7. Tighten jam nut.

IMPORTANT: Do not overtighten chain tensioner or chain and tightener will wear excessively.

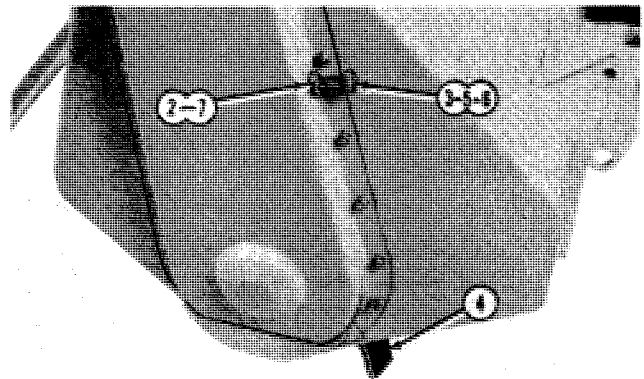

0A7/M28274 M19/20 D 240481

<https://www.ebooklibonline.com>

Hello dear friend!

Thank you very much for reading.

Enter the link into your browser.

The full manual is available for immediate download.

<https://www.ebooklibonline.com>