



Service Repair Manual

Models

D25C ARTICULATED
DUMP TRUCK

[Previous Screen](#)

Product: ARTICULATED TRUCK

Model: D25C ARTICULATED TRUCK 9YC

Configuration: D25C ARTICULATED DUMP TRUCK 9YC00001-01011 (MACHINE) POWERED BY 3306 ENGINE

Disassembly and Assembly 3304B and 3306B Engines for Caterpillar Built Machines

Media Number -SEN5598-09

Publication Date -01/01/2013

Date Updated -25/01/2013

i00903481

Fuel Ratio Control - Install

SMCS - 1278-012

Installation Procedure

NOTICE

Keep all parts clean from contaminants.

Contaminants may cause rapid wear and shortened component life.

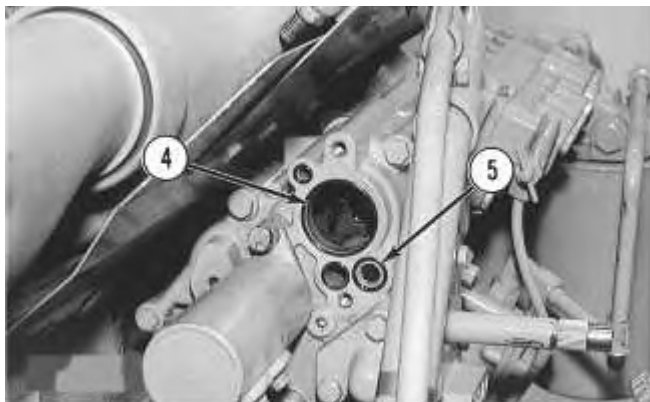

Illustration 1

g00460631

1. Screen assembly (5) and four O-ring seals (4) should be inspected, replaced and installed.
-

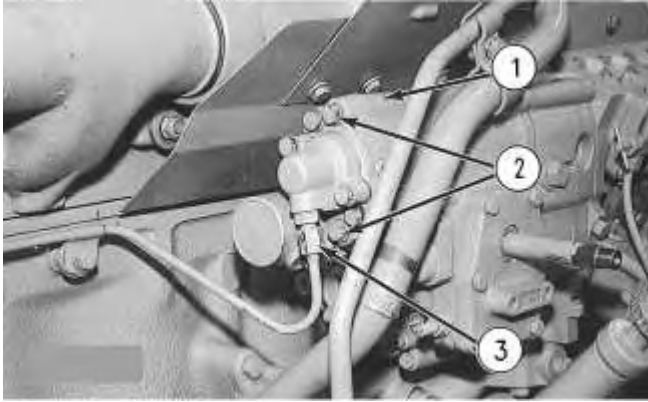

Illustration 2

g00460630

2. Put fuel ratio control (1) in position and engage the fuel ratio control with the lever assembly in the governor.
3. Install bolts (2) that hold the fuel ratio control and connect fuel pressure line (3) to fuel ratio control (1). Refer to Testing and Adjusting, "Fuel System" for more information on the adjustment procedure for the fuel ratio control.

<https://www.ebooklibonline.com>

Hello dear friend!

Thank you very much for reading.

Enter the link into your browser.

The full manual is available for immediate download.

<https://www.ebooklibonline.com>

[Previous Screen](#)

Product: ARTICULATED TRUCK

Model: D25C ARTICULATED TRUCK 9YC

Configuration: D25C ARTICULATED DUMP TRUCK 9YC00001-01011 (MACHINE) POWERED BY 3306 ENGINE

Disassembly and Assembly 3304B and 3306B Engines for Caterpillar Built Machines

Media Number -SEN5598-09

Publication Date -01/01/2013

Date Updated -25/01/2013

i00879991

Fuel Shutoff Solenoid - Remove and Install

SMCS - 1259-010

Removal Procedure

NOTICE

Keep all parts clean from contaminants.

Contaminants may cause rapid wear and shortened component life.

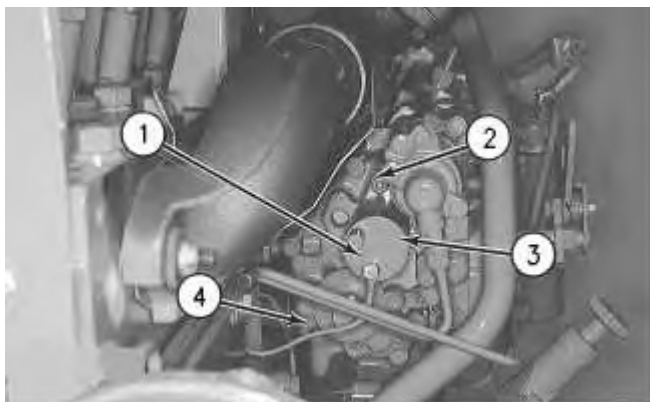

Illustration 1

g00475568

1. Remove nut (1) and the washer. Disconnect ground wire (4) from the fuel shutoff solenoid.
2. Remove two nuts (2) and the washers.

3. Remove fuel shutoff solenoid (3) and the gasket.

Installation Procedure

NOTICE

Keep all parts clean from contaminants.

Contaminants may cause rapid wear and shortened component life.

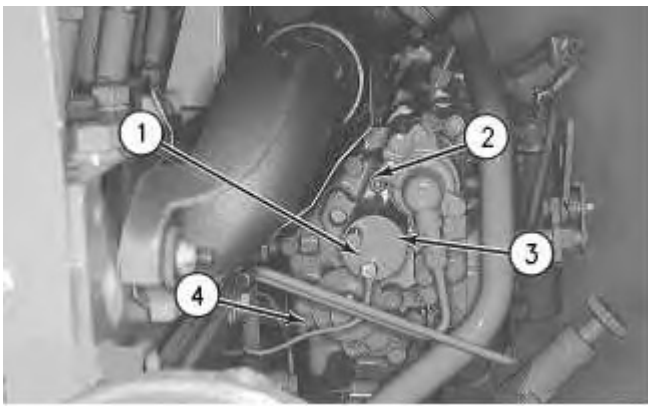

Illustration 2

g00475568

1. Install the gasket and fuel shutoff solenoid (3) .
2. Apply **9S-3263** Thread Lock Compound on the threads for two nuts (2) .
3. Install the washers and two nuts (2) .
4. Connect ground wire (4) to the fuel shutoff solenoid. Install nut (1) and the washer.

Previous Screen

Product: ARTICULATED TRUCK

Model: D25C ARTICULATED TRUCK 9YC

Configuration: D25C ARTICULATED DUMP TRUCK 9YC00001-01011 (MACHINE) POWERED BY 3306 ENGINE

**Disassembly and Assembly
3304B and 3306B Engines for Caterpillar Built Machines**

Media Number -SEN5598-09

Publication Date -01/01/2013

Date Updated -25/01/2013

i00930839

Automatic Timing Advance - Remove

SMCS - 1272-011

Removal Procedure

Table 1

Required Tools			
Tool	Part Number	Part Description	Qty
A	5P-7307	Engine Turning Tool	1
B	0T-0065	Bolt	1
C	9S-9155	Spacer	1
	8S-2264	Pump Impeller Puller	2
	0T-0513	Bolt	2
	5P-1075	Hard Washer	2

Start By:

- A. Remove the front housing. Refer to Disassembly and Assembly, "Front Housing - Remove".

NOTICE

Keep all parts clean from contaminants.

Contaminants may cause rapid wear and shortened component life.

1. Follow the procedure in Steps 3 and 4 in order to time the fuel injection pump when the front cover is removed. Follow the procedure in Steps 6 and 7 in order to time the fuel injection pump when the front cover is installed.

Note: The No. 1 piston should be at the top center position on the compression stroke at the start of all timing procedures.

Note: The engine is seen from the flywheel end when the direction of the crankshaft rotation is given.

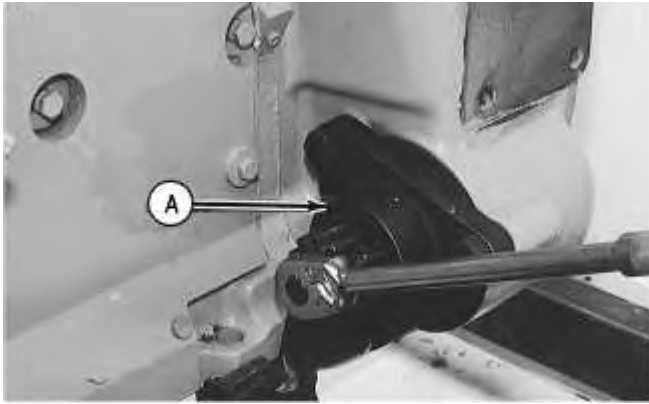

Illustration 1

g00474593

2. Remove the electric starting motor and install Tool (A) .

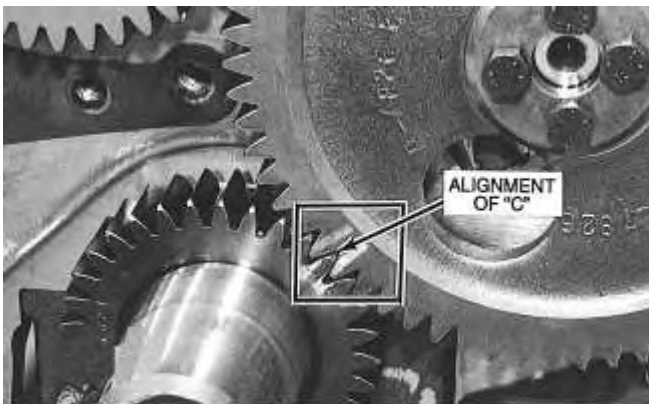

Illustration 2

g00474592

3. Turn the crankshaft counterclockwise until the "C" on the crankshaft gear and the "C" on the camshaft gear are in alignment.
-

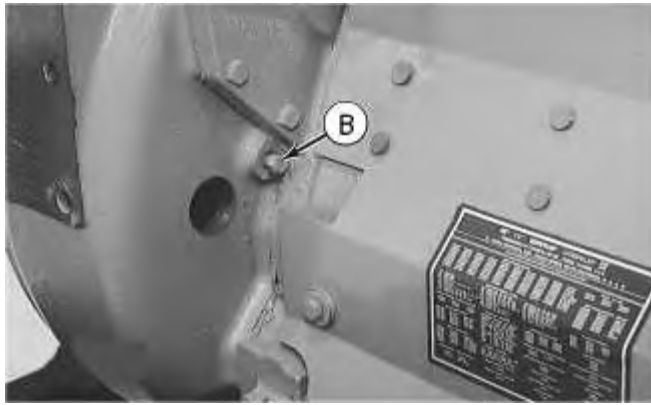

Illustration 3

g00474594

4. Remove two plugs and install Tool (B) in the flywheel housing. The large plug hole is for viewing.
5. To find the top center compression stroke for the No. 1 piston, use Tool (A) in order to turn the flywheel clockwise for approximately 30 degrees. This procedure should be used to remove all of the end play from the timing gears.
6. Use Tool (A) in order to turn the flywheel counterclockwise in the direction of the engine rotation until Tool (B) can be installed in the flywheel. The piston is at the top center position.

Note: If you go past the bolt hole, you must start the procedure again.

Note: Remove the breather assembly from the valve mechanism cover. The piston is at the top center position on the compression stroke when the inlet valve is closed and the exhaust valve is closed for the No. 1 cylinder. You must be able to move the rocker arms up and down with your hand.

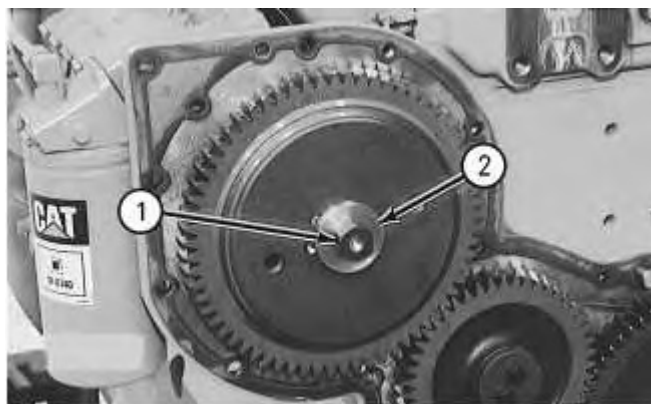

Illustration 4

g00474595

7. Remove bolt (1) and washer (2) that secures the automatic timing advance.

NOTICE

The automatic timing advance must have support during removal in order to help prevent damage to components.

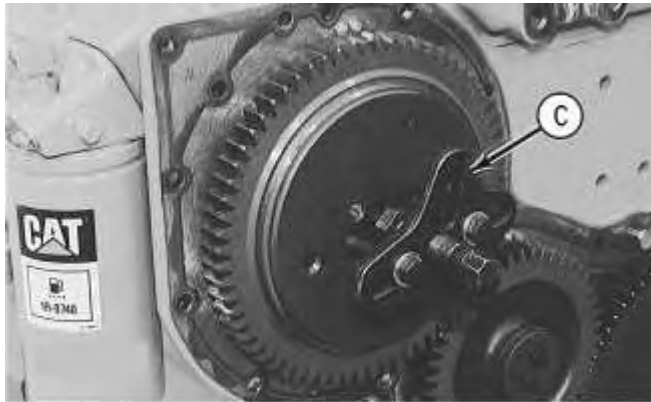

Illustration 5

g00474596

8. Install bolt (1) and leave a 6.35 mm (.250 inch) gap. Install Tool (C), as shown. Tighten the stud in order to loosen the fuel pump drive gear from the taper on the fuel injection pump camshaft.
9. Remove Tool (C) and bolt (1). Remove the automatic timing advance.

[Previous Screen](#)

Product: ARTICULATED TRUCK

Model: D25C ARTICULATED TRUCK 9YC

Configuration: D25C ARTICULATED DUMP TRUCK 9YC00001-01011 (MACHINE) POWERED BY 3306 ENGINE

Disassembly and Assembly 3304B and 3306B Engines for Caterpillar Built Machines

Media Number -SEN5598-09

Publication Date -01/01/2013

Date Updated -25/01/2013

i00935438

Automatic Timing Advance - Disassemble

SMCS - 1272-015

Disassembly Procedure

Start By:

- A. Remove the automatic timing advance unit. Refer to Disassembly and Assembly, "Automatic Timing Advance - Remove".

NOTICE

Keep all parts clean from contaminants.

Contaminants may cause rapid wear and shortened component life.

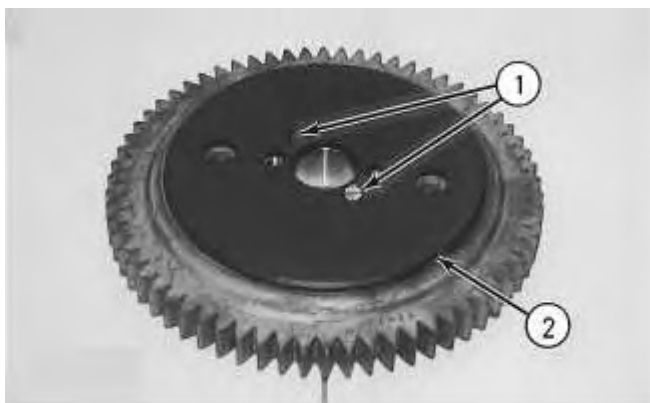

Illustration 1

g00476292

1. Remove two screws (1) and plate (2) .

NOTICE

The weights are held in position with two springs for each weight that is under compression. Carefully remove the weights and the springs in order to help prevent possible injury.

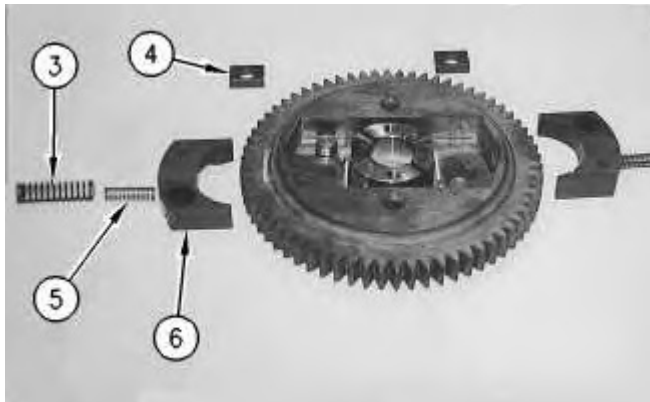

Illustration 2

g00476293

2. Remove springs (3) and (5), weight (6) and slide (4) from each side of the assembly.
-

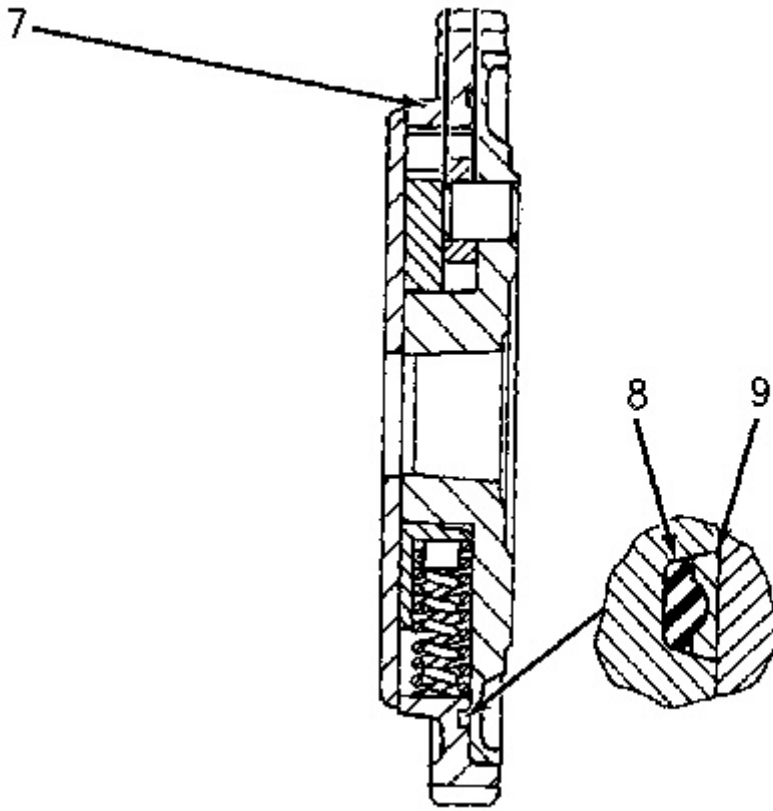

Illustration 3

g00476294

3. If necessary, remove gear (7). Remove seals (8) and (9) .

[Previous Screen](#)

Product: ARTICULATED TRUCK

Model: D25C ARTICULATED TRUCK 9YC

Configuration: D25C ARTICULATED DUMP TRUCK 9YC00001-01011 (MACHINE) POWERED BY 3306 ENGINE

Disassembly and Assembly 3304B and 3306B Engines for Caterpillar Built Machines

Media Number -SEN5598-09

Publication Date -01/01/2013

Date Updated -25/01/2013

i00935599

Automatic Timing Advance - Assemble

SMCS - 1272-016

Assembly Procedure

NOTICE

Keep all parts clean from contaminants.

Contaminants may cause rapid wear and shortened component life.

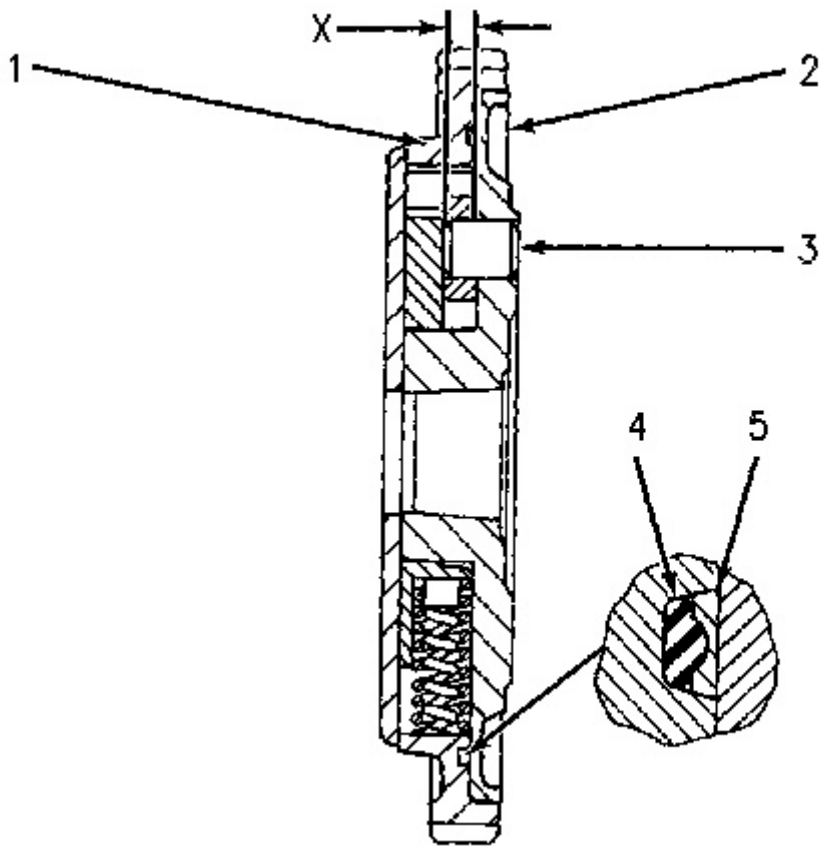

Illustration 1

g00476382

1. If dowels (3) were removed from the gear hub, installation dimension (X) is 9.00 ± 0.50 mm ($.354 \pm .020$ inch).
2. Install seals (4) and (5) .
3. Put gear (1) in position on hub assembly (2) .

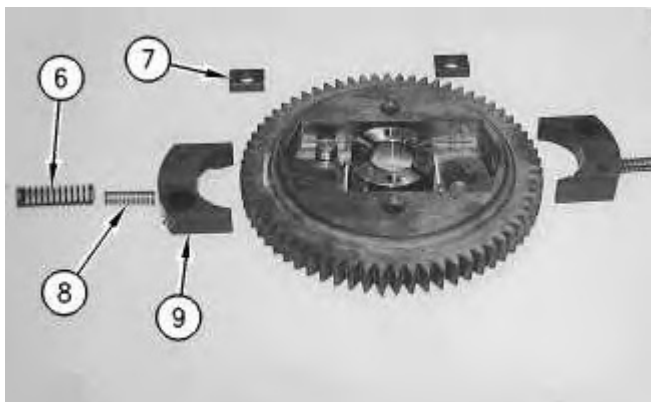

Illustration 2

g00476383

4. Install slide (7), weight (9) and springs (6) and (8) on each side of the assembly.

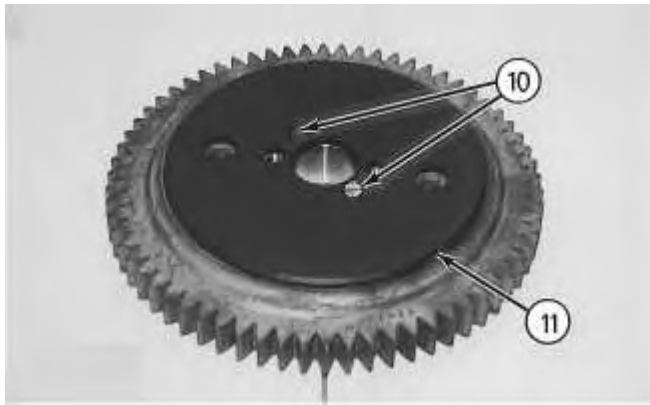

Illustration 3

g00476385

5. Install plate (11) with two screws (10) .

End By: Install the automatic timing advance unit. Refer to Disassembly and Assembly, "Automatic Timing Advance - Install".

[Previous Screen](#)

Product: ARTICULATED TRUCK

Model: D25C ARTICULATED TRUCK 9YC

Configuration: D25C ARTICULATED DUMP TRUCK 9YC00001-01011 (MACHINE) POWERED BY 3306 ENGINE

Disassembly and Assembly 3304B and 3306B Engines for Caterpillar Built Machines

Media Number -SEN5598-09

Publication Date -01/01/2013

Date Updated -25/01/2013

i00935398

Automatic Timing Advance - Install

SMCS - 1272-012

Installation Procedure

Table 1

Required Tools			
Tool	Part Number	Part Description	Qty
A	6V-4186	Fuel Pump Timing Pin	1
B	0L-2070	Bolt	1
C	5P-7307	Engine Turning Tool	1
D	4C-9874	Spanner Wrench	1

NOTICE

Keep all parts clean from contaminants.

Contaminants may cause rapid wear and shortened component life.



Illustration 1

g00476281

1. Install washer (1) and bolt (2). Ensure that the cover of the fuel pump housing is removed. Turn the fuel pump camshaft in the direction of the engine rotation until Tool (A) can be installed in the notch of the camshaft.
2. Install Tool (A) and (B) into position. Install the weight assembly for the timing advance on the fuel injection pump camshaft.



Illustration 2

g00476286

3. Use Tool (D) on the automatic timing advance and maintain a constant torque of 68 N·m (50 lb ft). Tighten the bolt that fastens the automatic timing advance to the fuel pump camshaft to a torque of 270 ± 25 N·m (200 ± 18 lb ft).
4. Remove Tools (A), (B), (C) and (D). Install the starting motor.

End By: Install the front housing. Refer to Disassembly and Assembly, "Front Housing - Install".

Previous Screen

Product: ARTICULATED TRUCK

Model: D25C ARTICULATED TRUCK 9YC

Configuration: D25C ARTICULATED DUMP TRUCK 9YC00001-01011 (MACHINE) POWERED BY 3306 ENGINE

**Disassembly and Assembly
3304B and 3306B Engines for Caterpillar Built Machines**

Media Number -SEN5598-09

Publication Date -01/01/2013

Date Updated -25/01/2013

i07103919

Fuel Injection Pump Housing and Governor - Remove

SMCS - 1286-011

Removal Procedure

Table 1

Required Tools			
Tool	Part Number	Part Description	Qty
A	8S-2264	Pump Impeller Puller	1
	8B-7560	Step Plate	1
	0T-0513	Bolt	2
	5P-1075	Hard Washer	2

Start By:

- a. Remove the fuel injection lines. Refer to Disassembly and Assembly, "Fuel Injection Lines - Remove and Install".

NOTICE

Keep all parts clean from contaminants.

Contaminants may cause rapid wear and shortened component life.

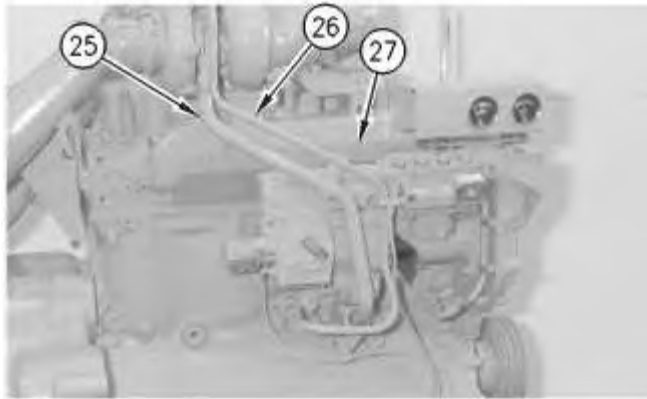

Illustration 1
3304B Engine

g00589938

1. On the 3304B engine, remove oil supply line (26), oil drain line (25), and heat shield (27). Inspect the O-ring seal around oil drain line (25). Replace the O-ring seal if the O-ring seal is damaged. Remove the gaskets and the screen from the top of the turbocharger.

Note: The following illustrations are of a 3306B engine.



Illustration 2

g00452289

2. Remove six nuts (1) and the washers and remove cover (2).

Note: Separate nut (1) and the mounting stud, if the nut and the mounting stud come out of the housing together. Apply thread sealant to the mounting studs and reinstall the mounting studs to a depth of 19.0 ± 0.8 mm (0.74 ± 0.03 inch).



Suggest:

If the above button click is invalid.

Please download this document

first, and then click the above link

to download the complete manual.

Thank you so much for reading

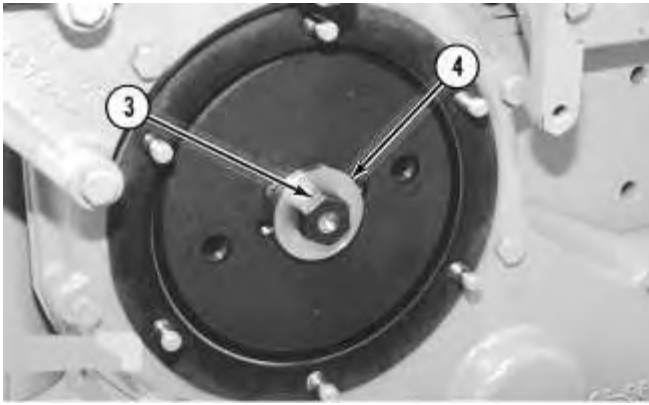

Illustration 3

g00452292

3. Remove center bolt (3) and spacer (4).

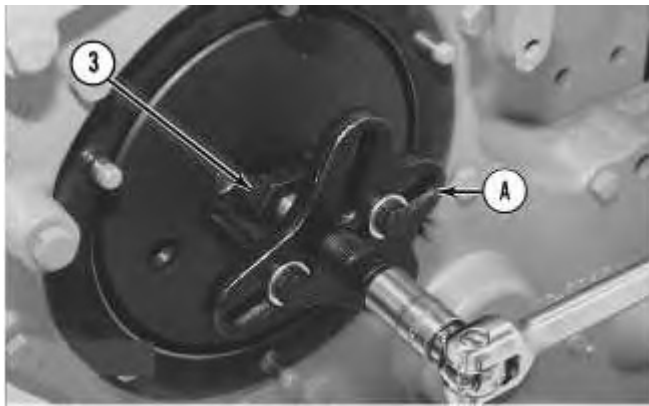

Illustration 4

g00452293

4. Install center bolt (3) and leave a gap of 6.4 mm (.25 inch). Install Tool (A), as shown. Tighten the stud to loosen the fuel pump drive gear from the taper on the fuel injection pump camshaft.
5. Remove Tool (A) and bolt (3).

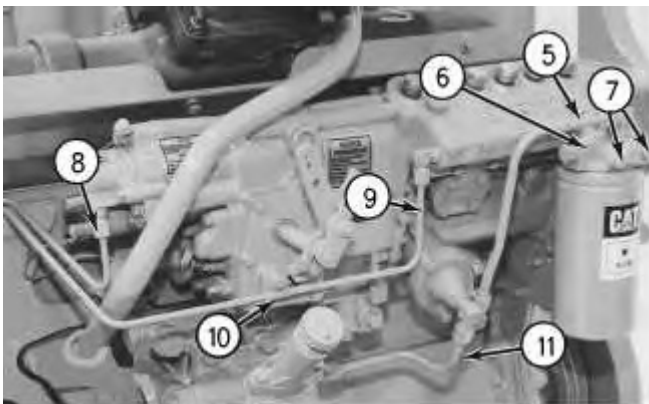

Illustration 5

g00452301

<https://www.ebooklibonline.com>

Hello dear friend!

Thank you very much for reading.

Enter the link into your browser.

The full manual is available for immediate download.

<https://www.ebooklibonline.com>