



Service Repair Manual

Models

D20D and D250D

ARTICULATED TRUCK

[Previous Screen](#)

Product: ARTICULATED TRUCK

Model: D20D ARTICULATED TRUCK 9MG

Configuration: D20D & D250D ARTICULATED TRUCK 9MG00001-UP (MACHINE) POWERED BY 3116 ENGINE

Disassembly and Assembly 3114, 3116 and 3126 MUI Engine Governors

Media Number -SEN6454-05

Publication Date -01/02/2002

Date Updated -01/03/2002

i01514770

Governor (Type II) - Disassemble

SMCS - 1264-015

Disassembly Procedure

Table 1

Required Tools			
Tool	Part Number	Part Description	Qty
A	1U-7307	Governor Repair Fixture ⁽¹⁾	1
B	1P-1855	Retaining Ring Pliers	1
C	1P-1857	Retaining Ring Pliers	1
D	1U-7606	Servo Block ⁽¹⁾	1
E	1U-7277	Pin Punch	1
F	1U-7635	Clevis Driver ⁽¹⁾	1

⁽¹⁾ Part of former 1U-9088 Governor Tool Group

NOTICE

Keep all parts clean from contaminants.

Contaminants may cause rapid wear and shortened component life.

NOTICE

Care must be taken to ensure that fluids are contained during performance of inspection, maintenance, testing, adjusting and repair of the product. Be prepared to collect the fluid with suitable containers before opening any compartment or disassembling any component containing fluids.

Refer to Special Publication, NENG2500, "Caterpillar Tools and Shop Products Guide" for tools and supplies suitable to collect and contain fluids on Caterpillar products.

Dispose of all fluids according to local regulations and mandates.

Note: Inspect all parts of the governor upon disassembly. For information on the reusability of components in the governor, refer to the Guideline For Reusable Parts And Salvage Operations, SEBF8434, "3100 Governor Inspection and General Information for Mechanical Governor Groups Used in 3114, 3116, and 3126 Engines Equipped with Mechanical Unit Injectors (MUI)". For information on cleaning the components in the governor, refer to the Cleaning Guide, SEBF8354, "Equipment And Chemical Recommendations Reference Manual".

Note: Refer to Chart A "Parts to be Replaced During Rebuild" in Guideline For Reusable Parts And Salvage Operations, SEBF8434 for a list of components that need to be replaced during a governor rebuild. It is not necessary to replace the components in Chart A "Parts to be Replaced During Rebuild" if the governor is in the shop for a bench test or for minor repair.

Note: Early Type II Governors had limited production until 1991. The early Type II Governors may be inspected and perhaps reconditioned. However, some of the internal components are no longer serviced or the internal components may only be serviced by larger assemblies. When you recondition a Type II Governor, it may be necessary to replace the governor. If extensive repair work is necessary, a Type II Governor can be replaced with a Type IV Governor.

<https://www.ebooklibonline.com>

Hello dear friend!

Thank you very much for reading.

Enter the link into your browser.

The full manual is available for immediate download.

<https://www.ebooklibonline.com>

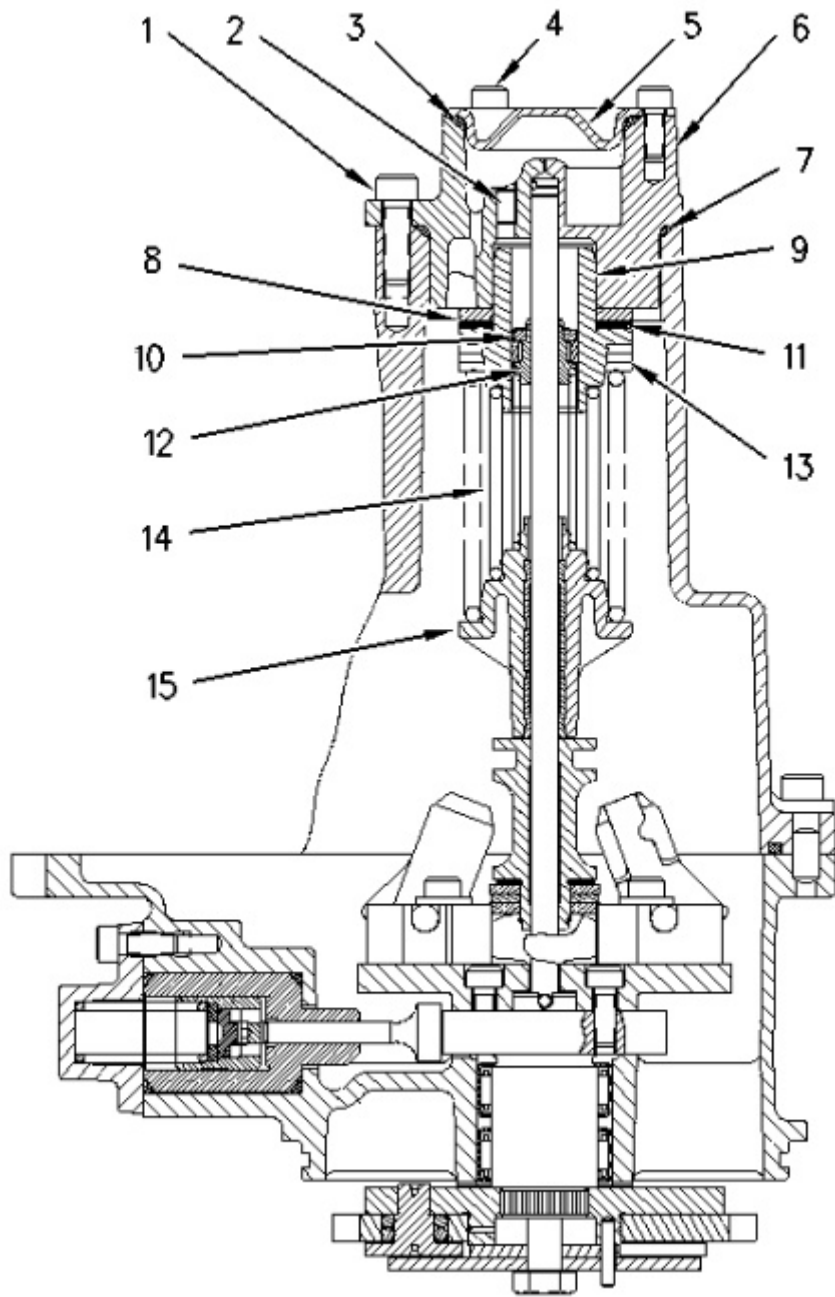

Illustration 1

g00521797

Typical Governor

- (1) Bolt
- (2) Orifice for the dashpot
- (3) O-ring seal
- (4) Bolt
- (5) Cover
- (6) Cover assembly
- (7) O-ring seal

- (8) Shims
- (9) Rear spring seat
- (10) Retaining ring
- (11) Spacer
- (12) Piston assembly for the dashpot
- (13) Shims for the high idle governor (if equipped)
- (14) Spring pair
- (15) Spring seat assembly

1. Mount the drive gear end of the governor on the **1U-7307** Governor Repair Fixture (Tool (A)).

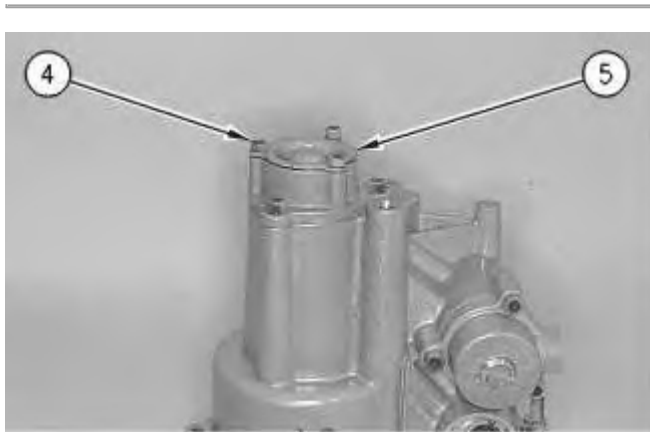

Illustration 2

g00521798

2. Remove three bolts (4) .
3. Remove cover (5) .



Illustration 3

g00521800

4. Remove O-ring seal (3) from cover (5). Inspect the O-ring seal for wear or damage. If the O-ring seal is worn or damaged, use a new part for replacement.

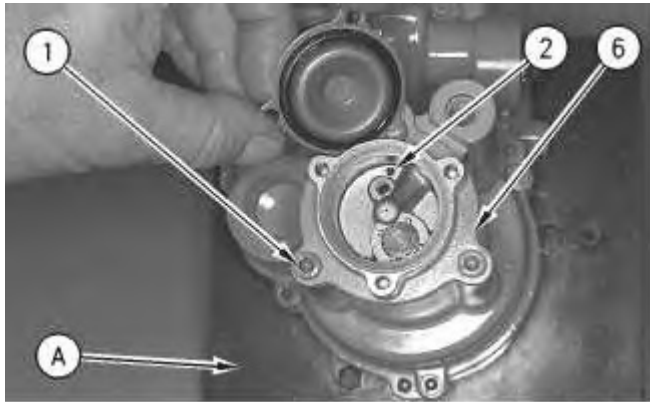

Illustration 4

g00521801

5. Ensure that orifice (2) for the dashpot is not plugged. Also ensure that orifice (2) is tight in the casting.

Note: The orifice for the dashpot may be drilled directly into the governor rear housing or the orifice may be a fitting that is staked into the governor rear housing. Ensure that all orifice fittings are staked into the governor housing before reassembly.

 **WARNING**

Personal injury can result from being struck by parts propelled by a released spring force.

Make sure to wear all necessary protective equipment.

Follow the recommended procedure and use all recommended tooling to release the spring force.

6. Use the following procedure in order to remove cover assembly (6) .
 - a. Hold cover assembly (6) in position and slowly loosen bolts (1) in order to release the spring force.
 - b. Remove three bolts (1) from the cover assembly.
 - c. Remove cover assembly (6) .
-

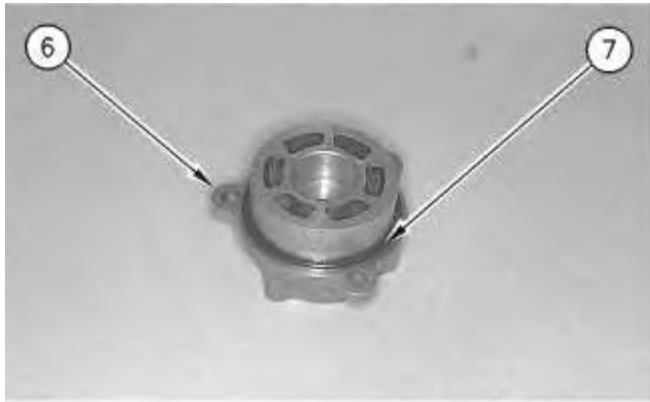

Illustration 5

g00521802

7. Remove O-ring seal (7) from cover assembly (6). Inspect the O-ring seal for wear or damage. If the O-ring seal is worn or damaged, use a new part for replacement.

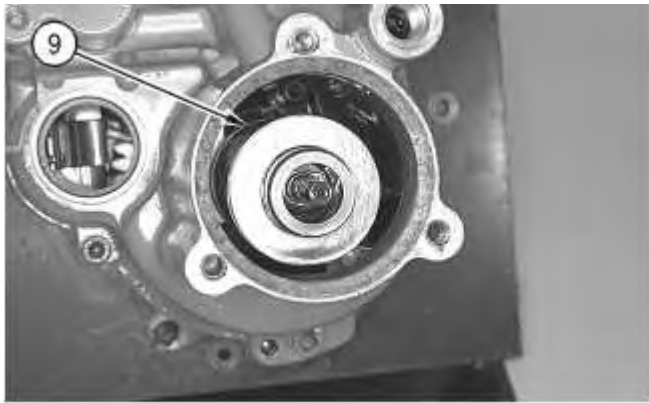

Illustration 6

g00521803

8. Remove governor spring seat assembly (9) .

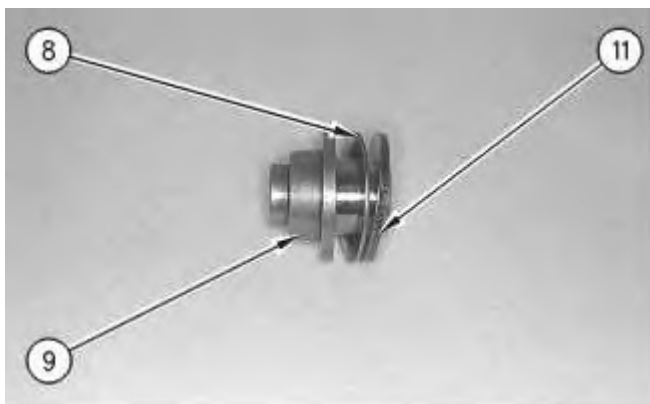

Illustration 7

g00522509

9. Remove spacer (11). Remove shims (8) from governor spring seat (9), if equipped.



Illustration 8

g00522514

10. Remove shims (13) for the high idle governor, if equipped.

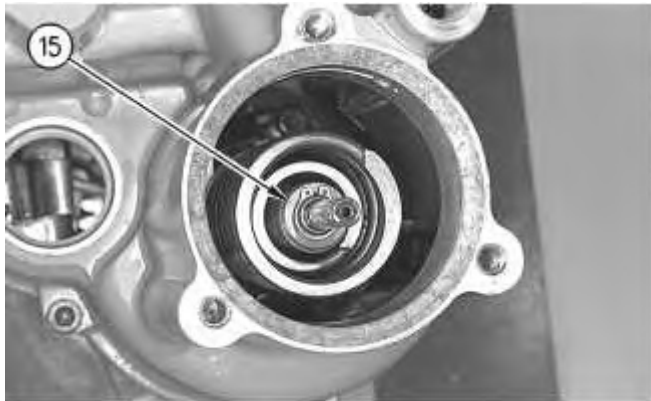

Illustration 9

g00522516

11. Remove spring seat assembly (15) from the governor.

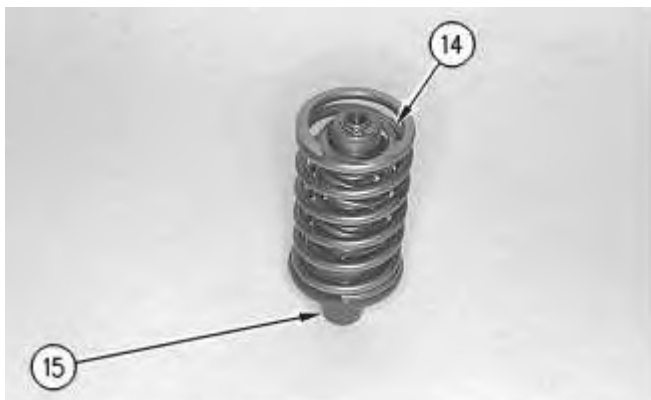

Illustration 10

g00522517

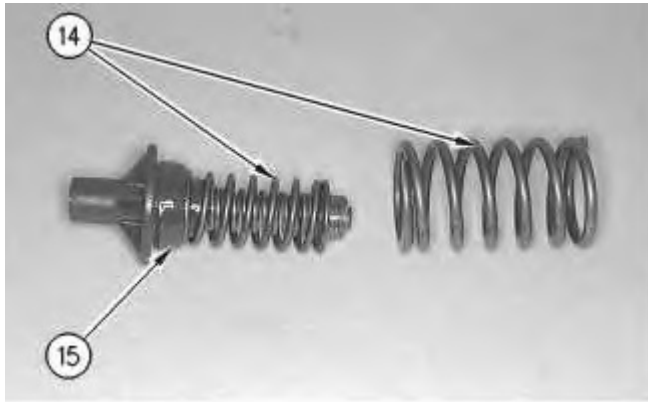

Illustration 11

g00522519

Note: Spring pair (14) can be removed by unscrewing the coils of the springs from spring seat assembly (15). Inspect the spring pair for wear or damage. Replace the spring pair as a spring group package only. The dashpot spring (if equipped) does not need to be replaced as part of the governor spring package.

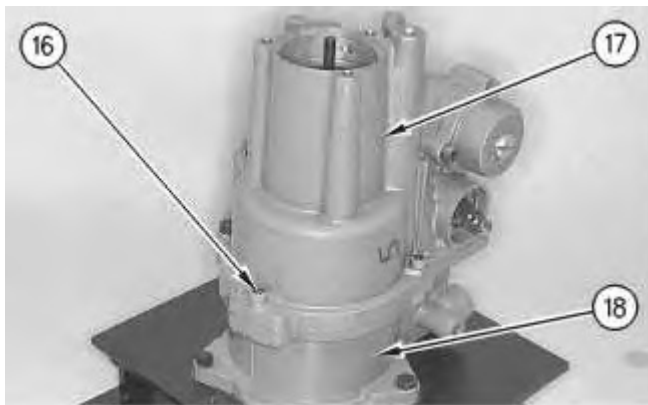

Illustration 12

g00522532

12. Remove six bolts (16) in order to separate governor rear housing (17) from governor front housing (18) .

Note: Steps 13 through 35 are for the disassembly of the governor front housing. Steps 36 through 53 are for the disassembly of the governor rear housing.

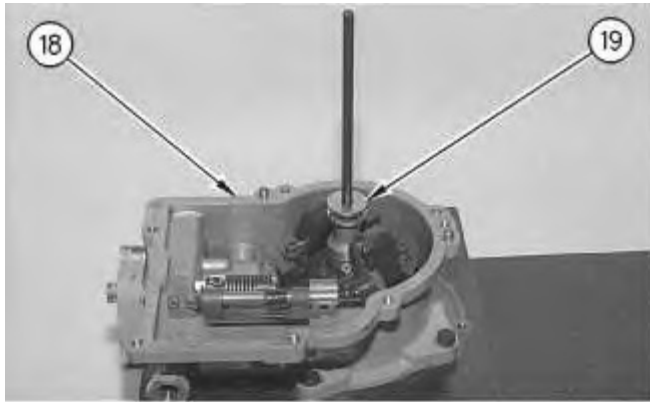

Illustration 13

g00522534

13. Remove riser (19) from governor front housing (18) .

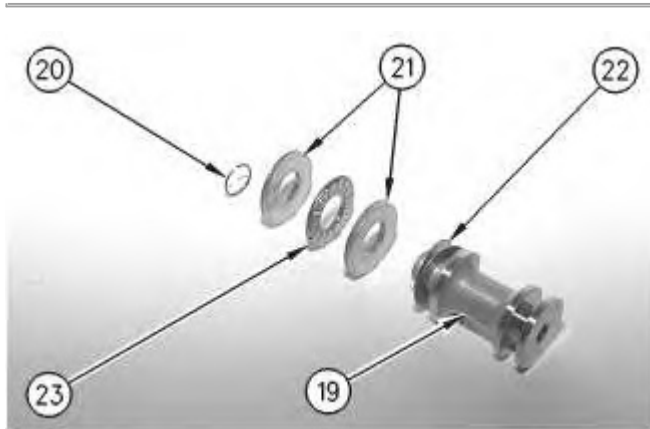

Illustration 14

g00522535

14. Remove retaining ring (20), two races (21), bearing (23) and shims (22) from riser (19) .

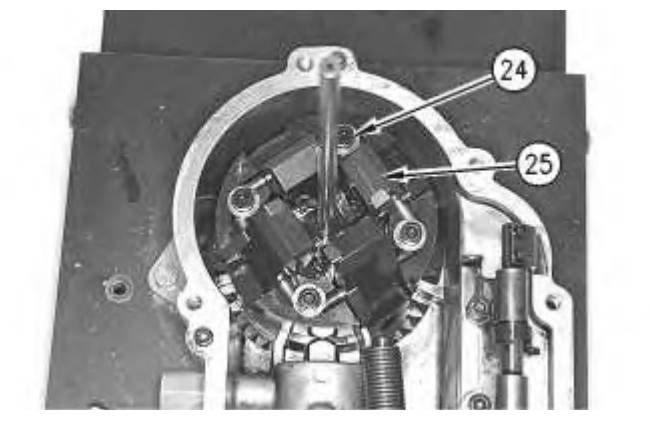

Illustration 15

g00575326

15. Remove four bolts and four washers (24) that hold the flyweights in position.

16. Remove flyweights (25) .

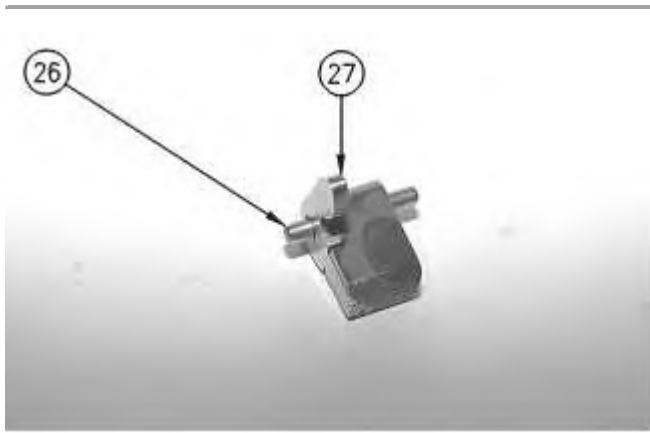

Illustration 16

g00522574

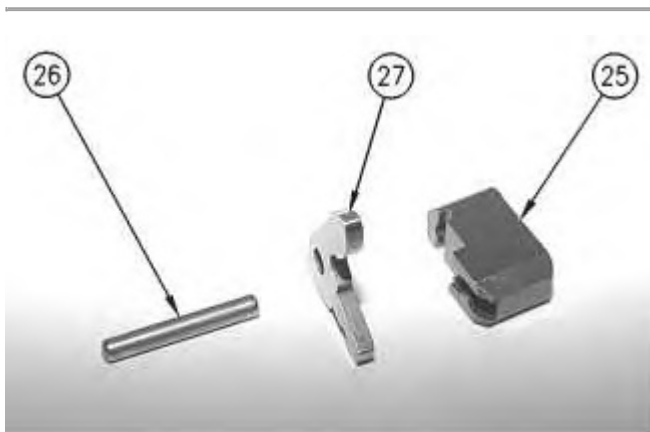

Illustration 17

g00522576

17. Remove flyweight pin (26). Inspect the pin for wear or damage.

18. Remove flyweight (25) from flyweight toe (27). Inspect the flyweight and the flyweight toe for wear or damage. If the flyweight or the flyweight toe is damaged, use new parts for replacement.

Note: Keep all parts of each flyweight together for assembly.

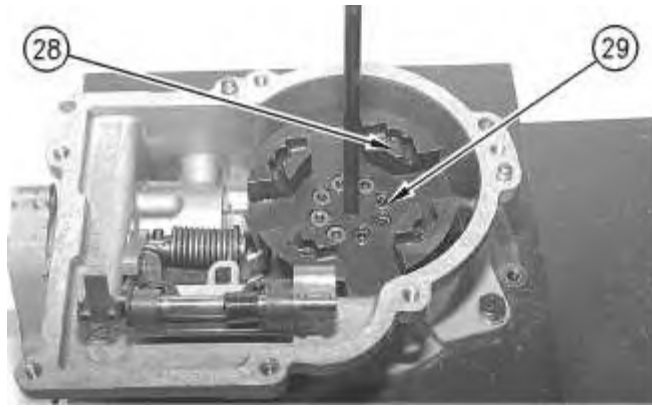

Illustration 18

g00522577

19. Hold flyweight carrier (28) in order to prevent the flyweight carrier from rotating and remove eight carrier bolts (29) .

Note: Upon assembly, do not reuse eight carrier bolts (29). Replace the used carrier bolts with new carrier bolts.

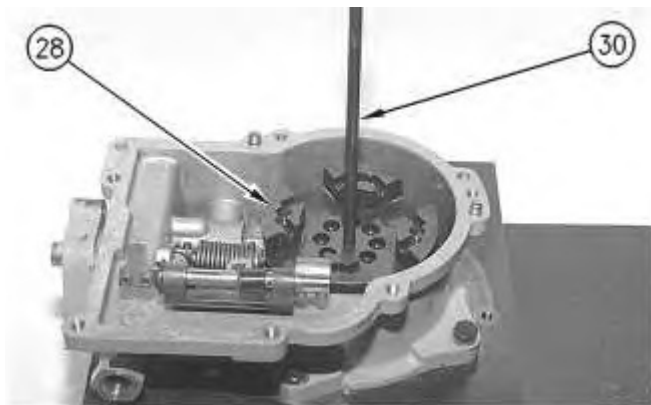
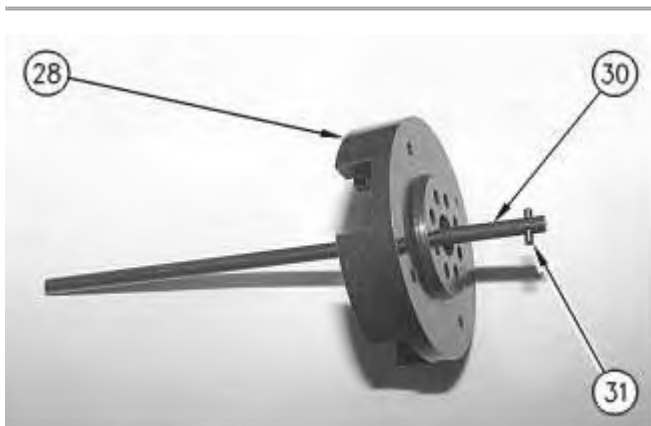

Illustration 19

g00522581

20. Remove flyweight carrier (28) and riser shaft (30) from the governor front housing.



21. Remove pin (31) from riser shaft (30). Remove riser shaft (30) from flyweight carrier (28). Inspect riser shaft (30) for wear or damage. If the riser shaft is worn or damaged, use a new part for replacement. Inspect pin (31) for wear or damage. If the pin is worn or damaged, use a new part for replacement.

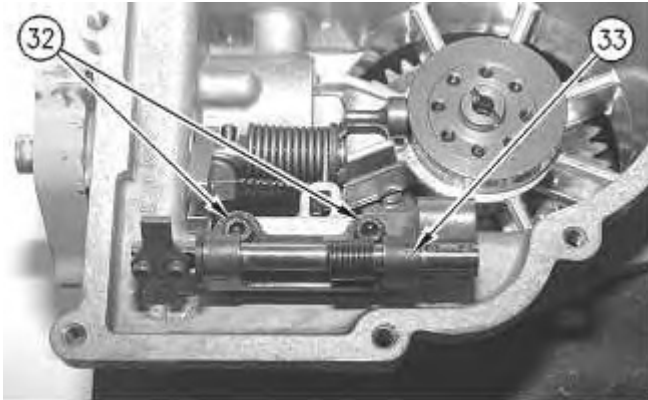

Illustration 21

g00522819

Note: Two types of shutoff assemblies are used. The first type was used on Types I, II, and III governors. The second type has a spring that is preloaded in the opposite direction. This is the bias spring.

22. Remove two bolts (32) and the washers.
23. Remove shutoff assembly (33). Inspect the shutoff assembly for wear or damage. If the shutoff assembly is worn or damaged, use new parts for replacement.

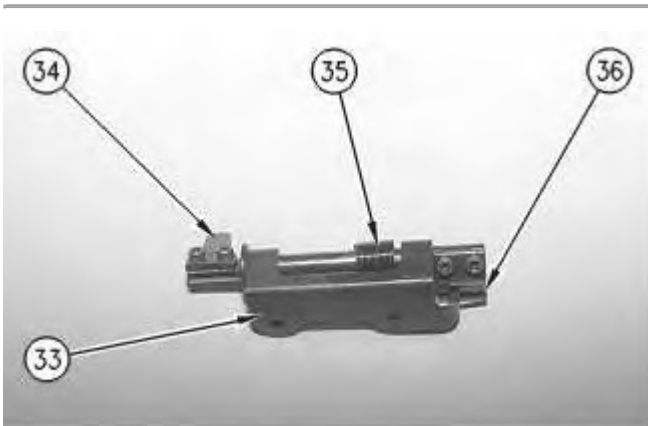

Illustration 22

g00522821

24. If necessary, remove blade (34) and blade (36). Do not remove spring (35) .

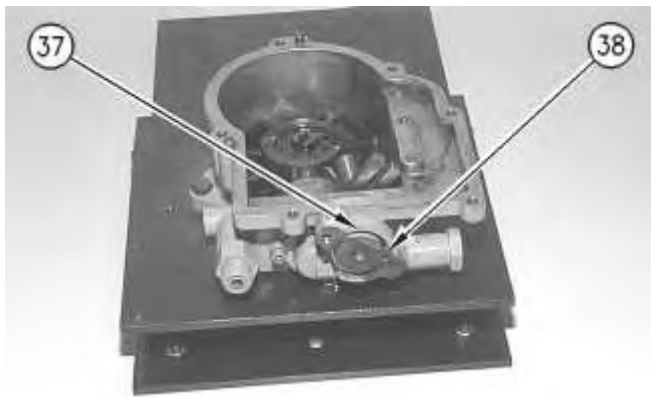

Illustration 23

g00522822

25. Remove spring (38) for the throttle lever from throttle shaft (37) .

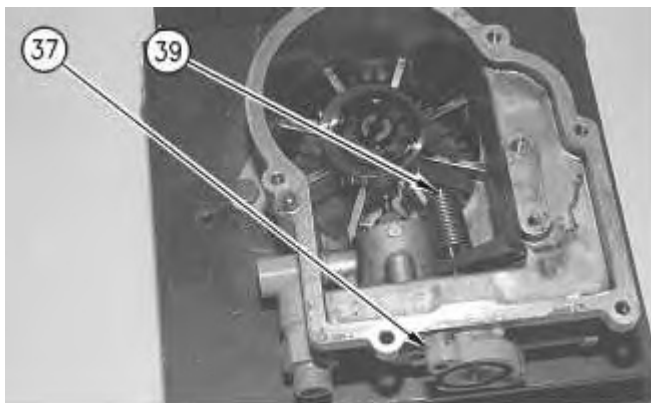

Illustration 24

g00522823

26. Remove retaining clip (39) from throttle shaft (37) .



Illustration 25

g00522826

27. Remove spacer (43), spring (42), setscrew (41), and control lever (40) from throttle shaft (37) .

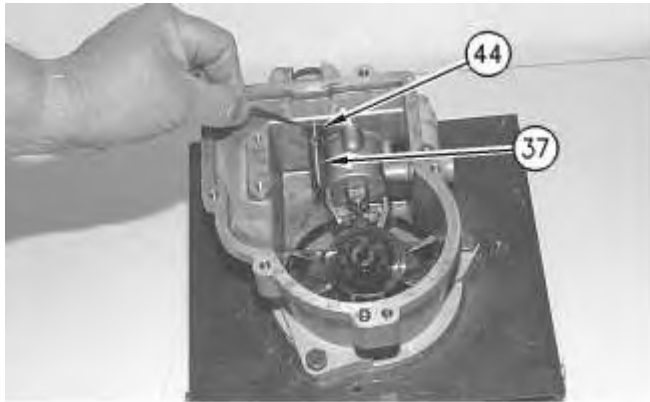

Illustration 26

g00522898

28. Remove retaining clip (44) from throttle shaft (37) .

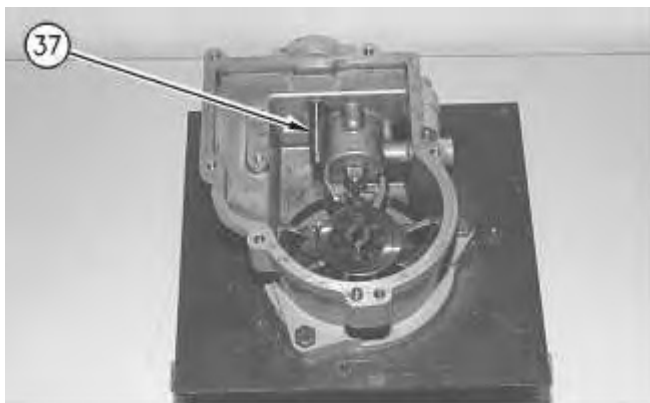

Illustration 27

g00522900

29. Remove throttle shaft (37) from the governor front housing. Inspect the throttle shaft for wear or damage. If the throttle shaft is worn or damaged, use a new part for replacement.
-

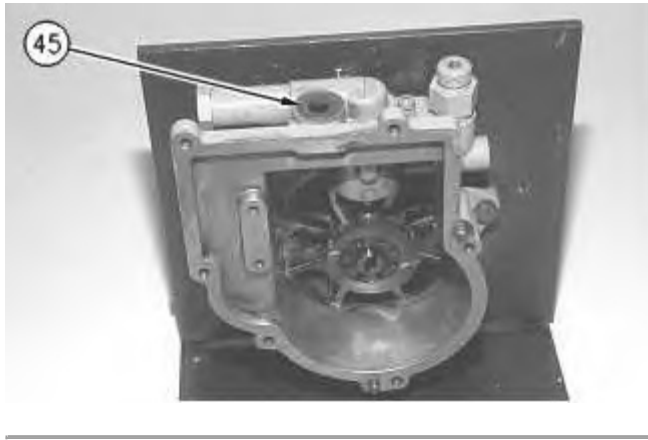

Illustration 28

g00522902

30. Inspect throttle shaft seal (45) carefully for wear or damage. If the throttle shaft seal is worn or damaged, use a new part for replacement.

⚠ WARNING

Personal injury can result from being struck by parts propelled by a released spring force.

Make sure to wear all necessary protective equipment.

Follow the recommended procedure and use all recommended tooling to release the spring force.

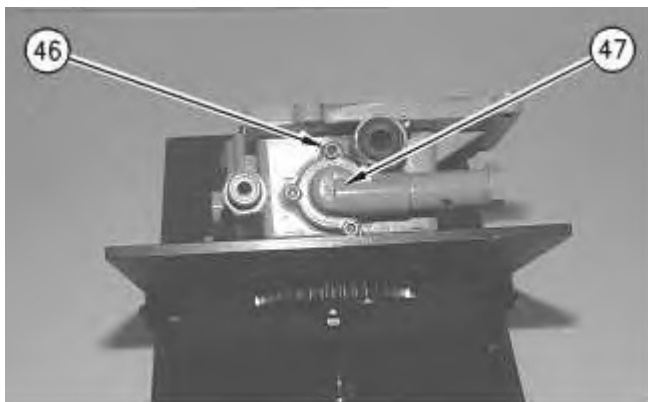

Illustration 29

g00522904

31. Use the following procedure in order to remove cover assembly (47) .
 - a. Hold cover assembly (47) in position and slowly loosen bolts (46) in order to release the spring force.
 - b. Remove three bolts (46) and cover (47) .



Illustration 30

g00522905

32. Remove spring (48) and O-ring (49). Inspect the O-ring for wear or damage. If the O-ring is worn or damaged, use a new part for replacement.

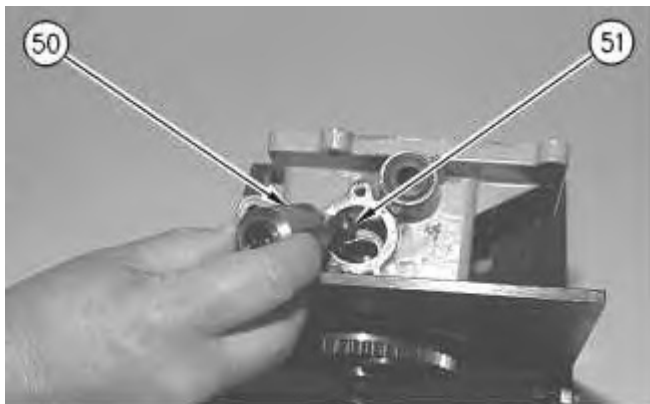
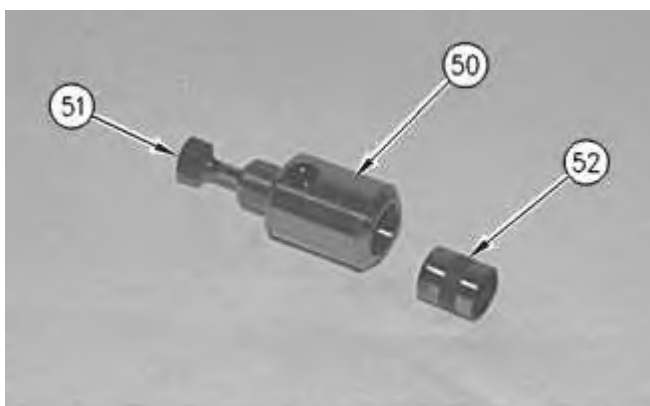

Illustration 31

g00522950

33. Remove sleeve assembly (50) and tappet assembly (51) from the governor front housing.



34. Remove piston (52) from sleeve assembly (50). Inspect the condition of piston (52) and sleeve assembly (50). If the piston or the sleeve assembly are worn or damaged, use new parts for replacement.



Illustration 33

g00522952

35. Remove lower O-ring seal (53) from the fuel transfer pump housing. Check the O-ring seal for wear or damage. If the O-ring seal is worn or damaged, use a new part for replacement.

Note: Remove the governor front housing from the **1U-7307** Governor Repair Fixture (Tool (A)).

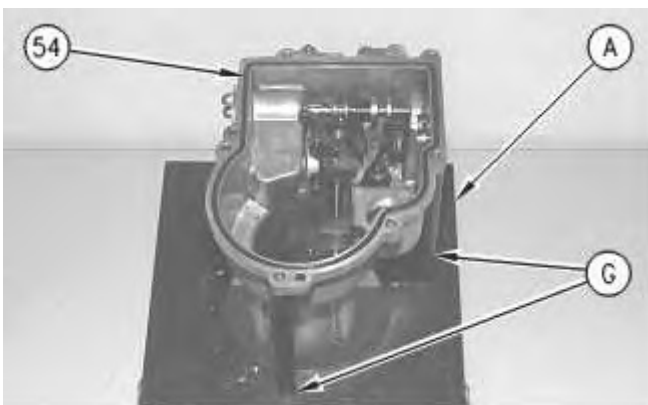

Illustration 34

g00522953

36. Install three legs (G) on the **1U-7307** Governor Repair Fixture (Tool (A)). Mount the governor rear housing on the three legs.
 37. Remove seal (54) from the governor rear housing. Inspect the seal for damage. If the seal is damaged, use a new part for replacement.
-

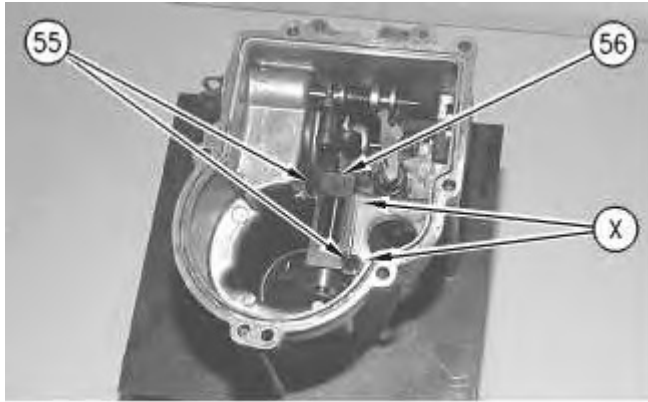

Illustration 35

g00522954

NOTICE

The position of the bearing block will affect the output of the fuel rack. If the bearing block assembly is positioned too close to the riser lever, high idle may not be reached. If the bearing block assembly is positioned too far from the riser lever, fuel shutoff may not be obtained.

Note: Use a scribe to mark the location of the bearing block on the aluminum housing near the hole for the fuel shutoff solenoid. Scribe marks (X) should indicate the vertical position of the bearing block and the horizontal position of the bearing block. Scribe the marks close to the bearing block.

38. Remove two bolts (55) and the washers. Remove bearing block (56) .

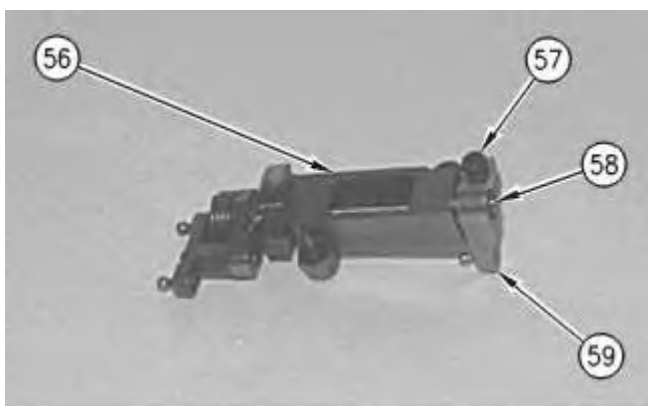

Illustration 36

g00523003

39. Use Tool (B) to remove retaining ring (58). Loosen bolt (57). Remove riser lever (59) from bearing block assembly (56) .

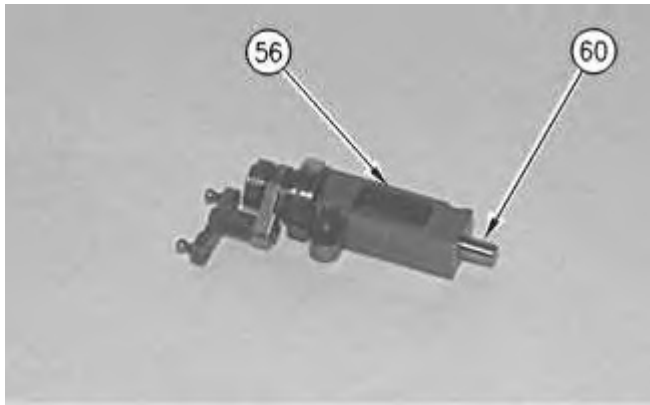

Illustration 37

g00523005

40. Remove bearing block assembly (56) from pivot shaft (60) .

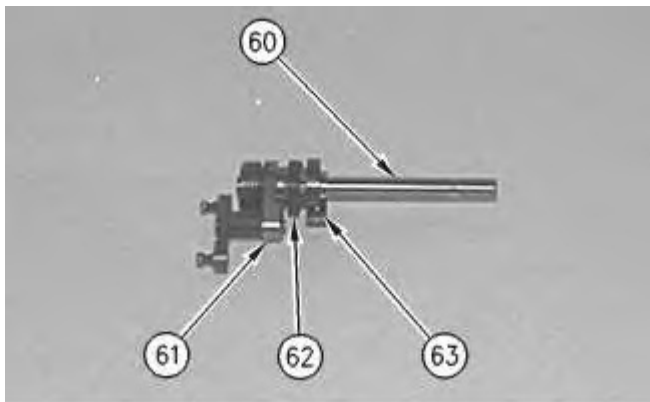

Illustration 38

g00523007

41. Remove adjuster (63) for the torque cam from pivot shaft (60). Remove torsion spring (62) from pivot shaft (60). Inspect the condition of the parts on pivot shaft (60). If any of the parts are worn or damaged, use new parts for replacement.
 42. Remove fulcrum lever (61) from pivot shaft (60). Remove the spring from the end of pivot shaft (60) .
-

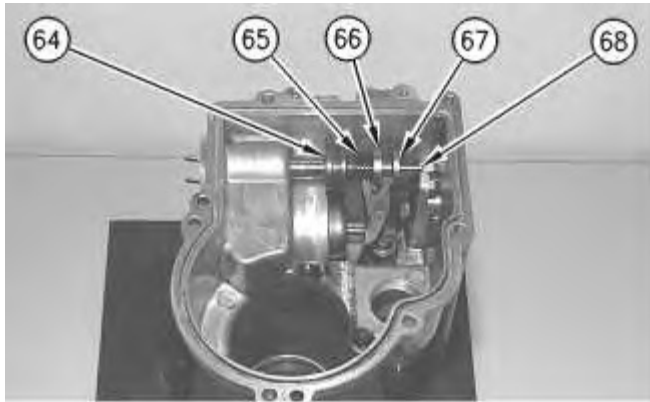

Illustration 39

g00523008

43. Push limit sleeve (66) and control sleeve (64) toward each other and compress spring (65) in order to expose retaining clip (67). Remove retaining clip (67) from governor output servo (68). Inspect the parts of the servo assembly for wear or damage.

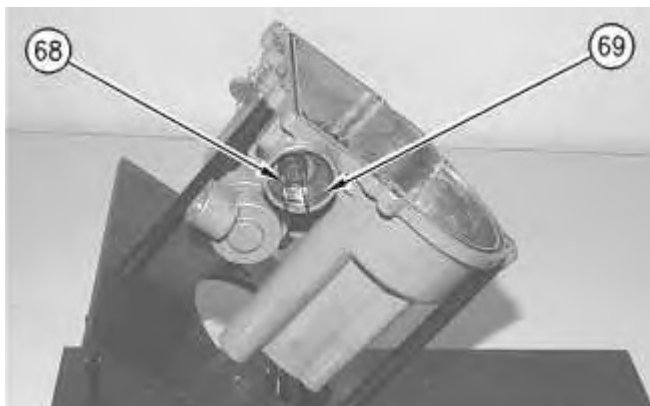

Illustration 40

g00523033

44. Remove retaining ring (69) with Tool (C). Remove the shaft of governor output servo (68) by pulling out on the clevis.

Note: Limit sleeve (66), spring (65), and control sleeve (64) will come out of the governor housing when the governor output shaft is removed.

45. Inspect the governor output shaft for wear or for damage. If the governor output shaft is worn or damaged, use a new part for replacement.



Suggest:

If the above button click is invalid.

Please download this document

first, and then click the above link

to download the complete manual.

Thank you so much for reading

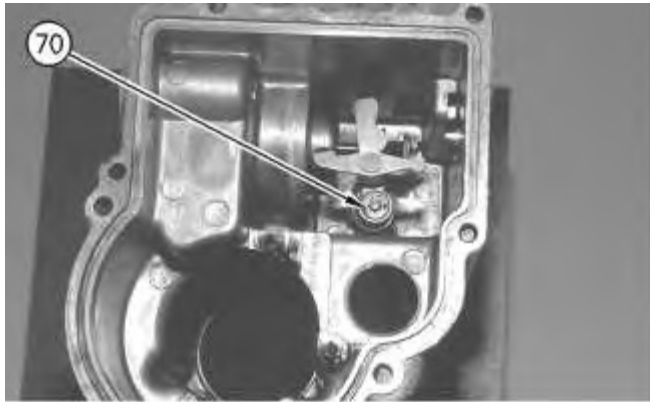

Illustration 41

g00697644

46. Remove retaining clip (70) .

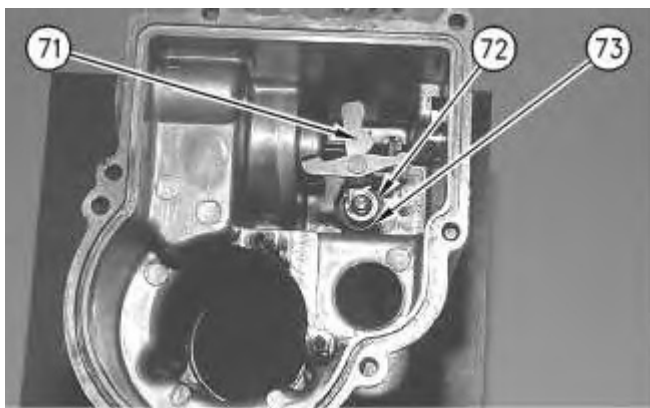

Illustration 42

g00697646

47. Remove washer (72), limit lever assembly (71), and spring (73). Inspect the condition of limit lever (71) .

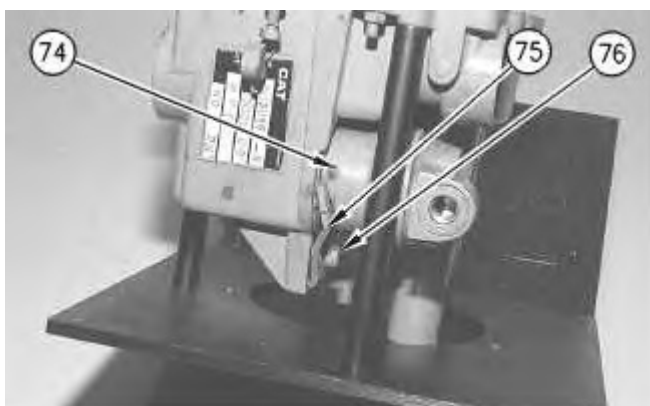

Illustration 43

g00697652

<https://www.ebooklibonline.com>

Hello dear friend!

Thank you very much for reading.

Enter the link into your browser.

The full manual is available for immediate download.

<https://www.ebooklibonline.com>