



Service Repair Manual

Models

**D5C III TRACK-TYPE
TRACTOR Dozer**

[Previous Screen](#)

Product: TRACK-TYPE TRACTOR

Model: D5C III TRACK-TYPE TRACTOR 9DL

Configuration: D5C Series III Tractor Direct Drive Power Shift 9DL02550-02569 (MACHINE) POWERED BY 3046 Engine

Disassembly and Assembly D3C, D4C AND D5C SERIES II TRACTORS POWER TRAIN

Media Number -SEN5337-02

Publication Date -01/08/2004

Date Updated -15/02/2017

SENR53370018

Steering Clutches

SMCS - 4101-011; 4101-012; 4101-015; 4101-016; 4109

Remove Steering Clutches (Oil Cooled)

Tools Needed		A
1P510	Driver Group	1

Start By:

a. remove hydraulic tank*

b. remove fuel tank*

*These operations are in the Disassembly And Assembly Manual, machine systems, Form No. SENR5341.

1. Drain the oil from the steering clutch compartment.

2. Remove the battery and battery frame.

3. Remove seat and seat frame.

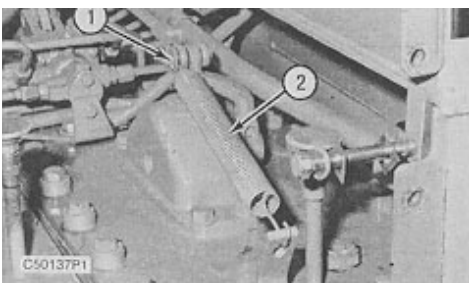

4. Remove spring (2) and brake linkage (1).

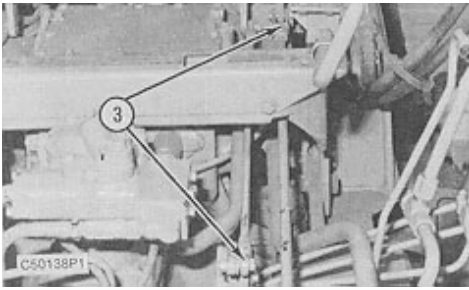

5. Disconnect steering clutch linkage (3) from the pedal assembly and steering control valve.

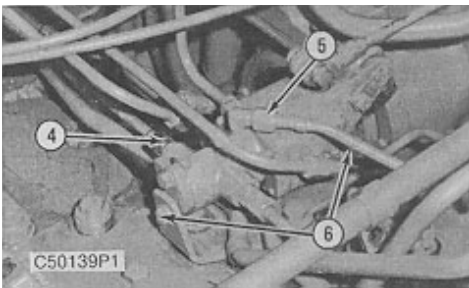

6. Disconnect seven lines (4) from control valve (5).

7. Remove three bolts (6) and remove control valve (5).

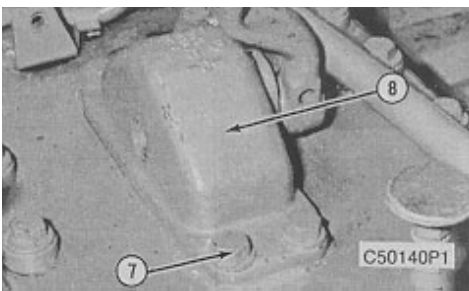

8. Remove four bolts (7) that hold brake housing (8) in place.

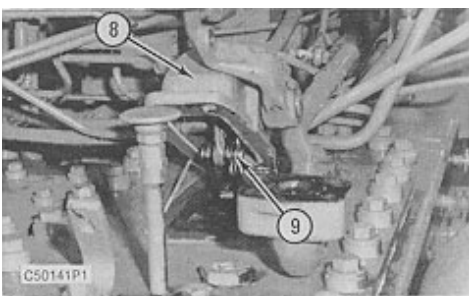

9. Lift brake housing (8) up and remove pin lock (9). Remove the pin and brake housing (8).

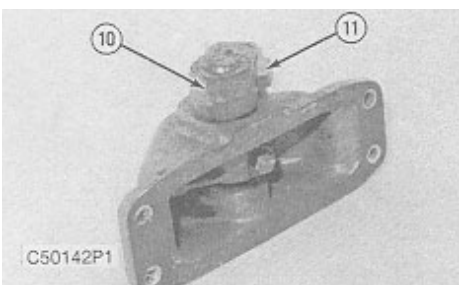

<https://www.ebooklibonline.com>

Hello dear friend!

Thank you very much for reading.

Enter the link into your browser.

The full manual is available for immediate download.

<https://www.ebooklibonline.com>

10. Remove bolt (11) and remove lever (10) from the shaft. Remove the key from the shaft.

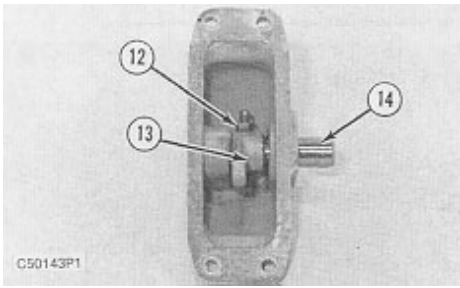

11. Loosen nut (12) and slide shaft (14) from the brake housing. Remove the key from the shaft. Remove lever (13) from the brake housing.

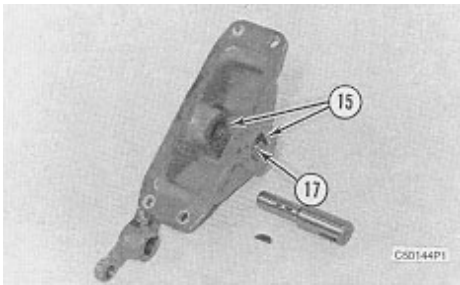

12. Inspect and replace, if needed, lip-type seal (16).

13. Inspect and replace, if needed, bearings (15). Use tooling (A) to remove and install bearings.

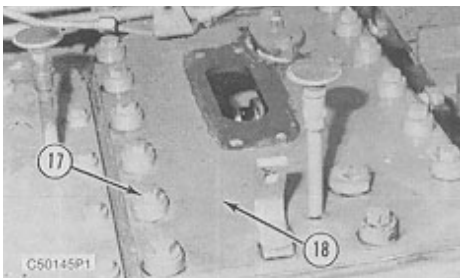

14. Remove nineteen bolts (17) washers and spacers and remove cover (18).

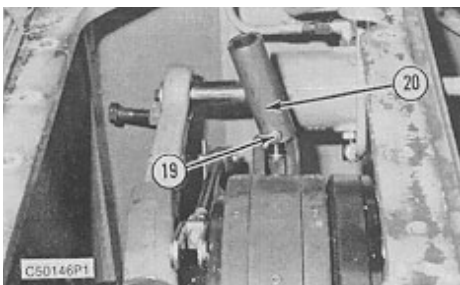

15. Remove nut and bolt (19) and remove sleeve (20).

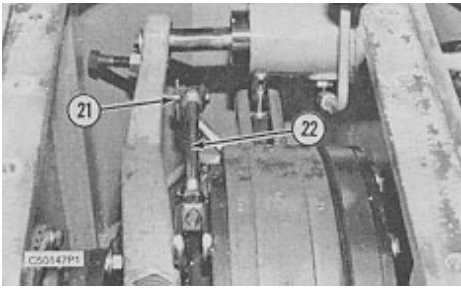

16. Remove the cotter pin and pin (21) that hold brake linkage (22) in place and remove linkage (22).

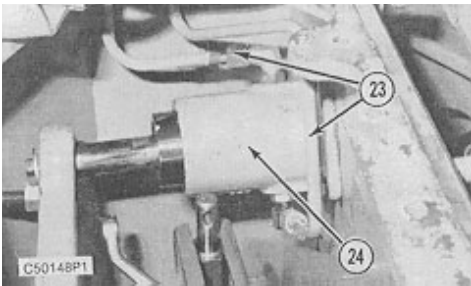

17. Remove two oil lines (23) from the clutch cylinder (24).

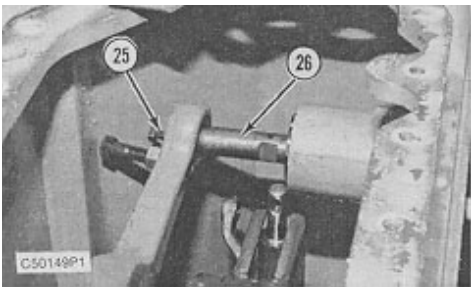

18. Disconnect yoke by removing bolt (25). Remove pin (26) from the clutch cylinder.

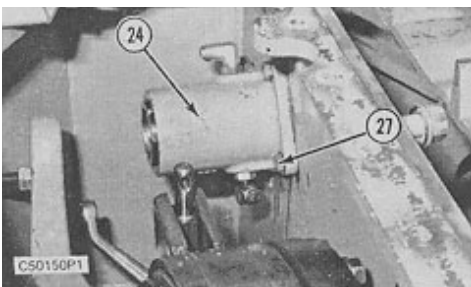

19. Remove four bolts (27) and remove cylinder (24).

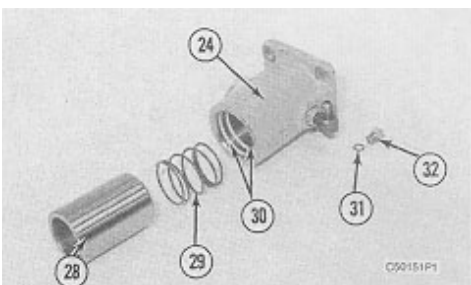

20. Remove piston (28) and spring (29).

21. Remove plug (32) and O-ring seal (31) from cylinder (24).

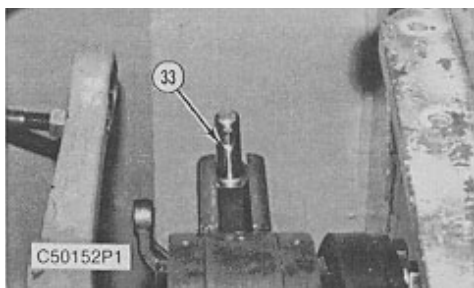

22. Remove bar (33).

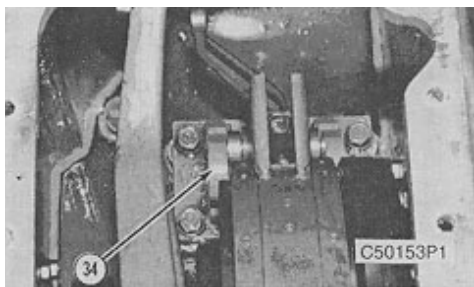

23. Remove four bolts that hold brake band support (34) in position on bottom of steering clutch compartment, and remove the support.

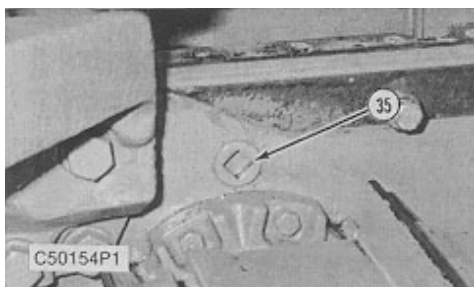

24. Remove plug (35) for access to bolts that hold final drive pinion flange to steering clutch.

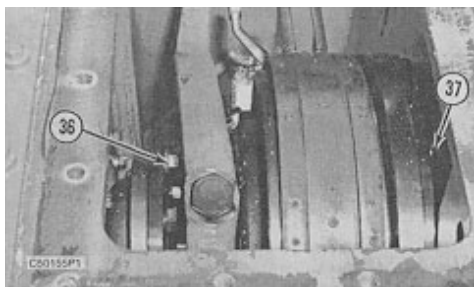

25. Push the tractor forward or backward to turn the steering clutch. Remove bolts (36) and (37) except for one on each side of the steering clutch.

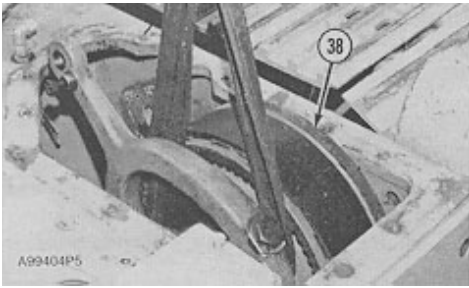

26. Fasten a hoist to steering clutch (38). Remove the last two bolts and remove steering clutch (38) from the steering clutch compartment. The weight of the steering clutch is **74 kg (165 lb)**.

27. Step are the same for removal of both sides.

Install Steering Clutches (Oil Cooled)

Tools Needed		A
1P510	Driver Group	1

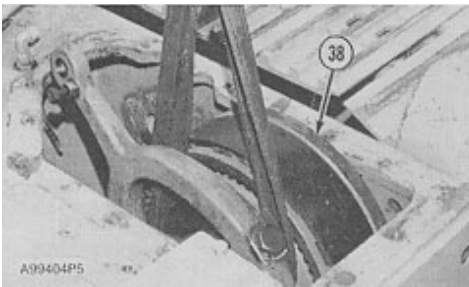

1. Put **5P0960 Multipurpose Grease** on the ball and insert at each end of the yoke on the steering clutch. Fasten a hoist and position steering clutch (38) in the steering clutch compartment.

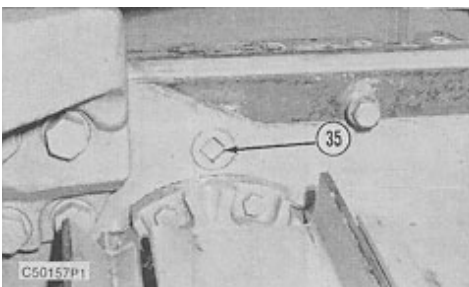

2. Put **5P3413 Thread Sealant** on the threads of plug (35) and install the plug.

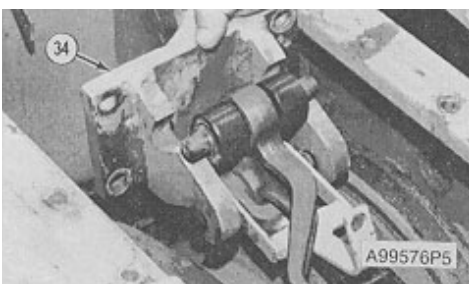

3. Put support (34) in position on the brake band and turn the brake band and support to the bottom of the steering clutch compartment. Install the four bolts that hold the support in place.

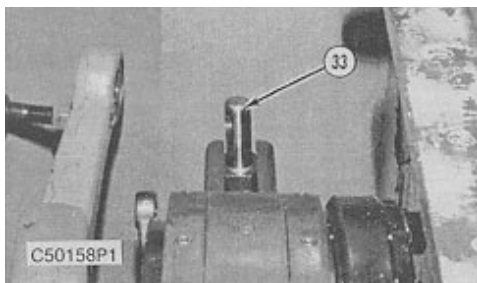

4. Install bar (33).

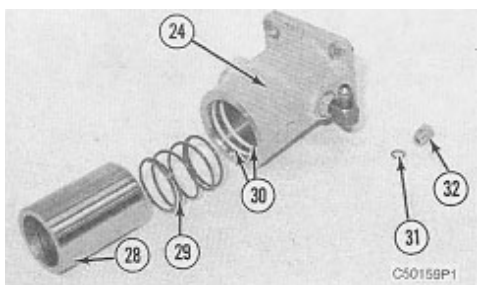

5. Install seals (30) in cylinder. Install spring (29) and piston (28) in cylinder (24).

6. Install O-ring seal (31) on plug (32), and install the plug in cylinder (24).

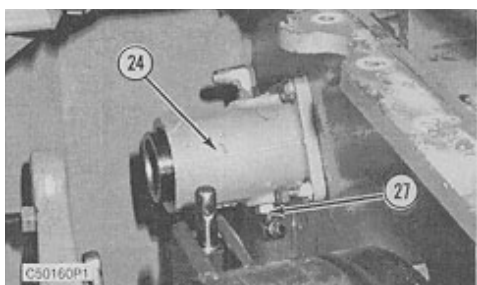

7. Put **7M7260 Liquid Gasket Material** on the base of cylinder (24). Put cylinder (24) in position in the steering clutch compartment.

8. Put **5P3413 Pipe Sealant** on the threads of bolts (27) that hold the cylinder in place, and install the bolts.

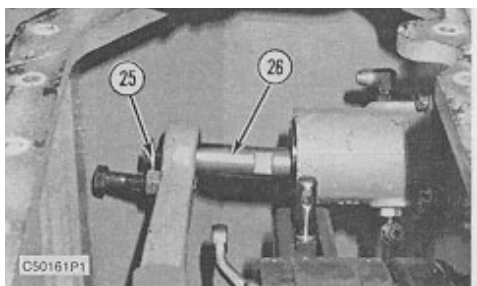

9. Install pin (26) and bolts and washer (25).

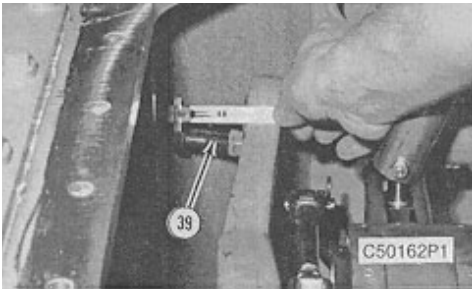

10. If necessary, make an adjustment to bolt (39) until the distance between the bolt and the steering clutch housing is **8 mm (.315 in.)**.

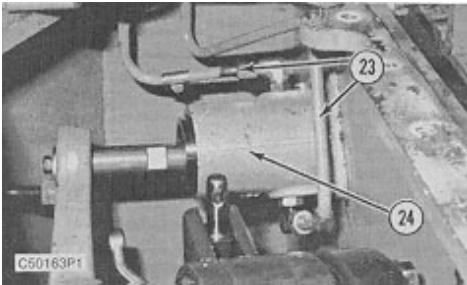

11. Connect two oil line (23) to cylinder (24).

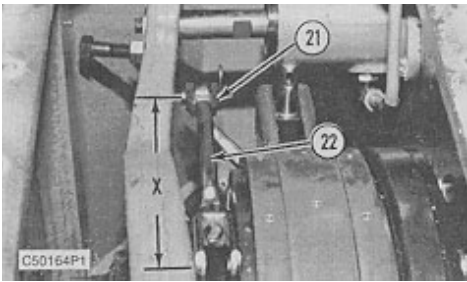

12. Install linkage (22) with the pin and cotter pin (21).

NOTE: The length (X) should measure **367 ± 1.5 mm (14.45 ± 0.06 inch.)** Length (X) is measures from the center of each pin.

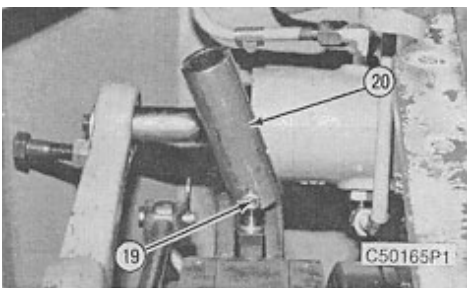

13. Install sleeve (20) and bolt and nut (19).

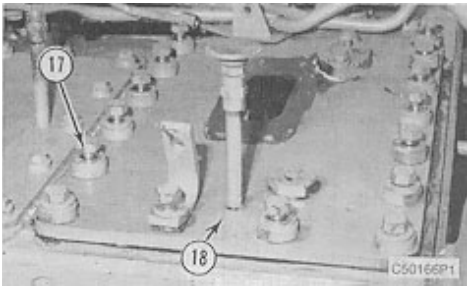

14. Put **3S6252 Sealant** on the contact surfaces of cover (18) and the steering clutch case. Put cover (18) in position. Put **5P3413 Thread Lubricant** on the threads of the bolts (17) that hold cover to the steering clutch case. Install the bolts.

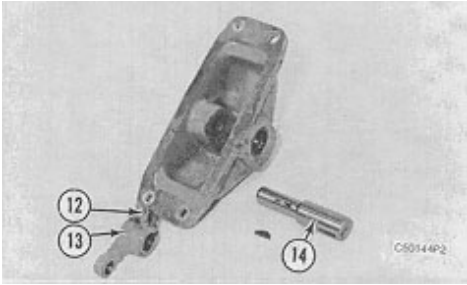

15. Install key in shaft (14). Install shaft (14) in housing through lever (13). Tighten bolt (12).

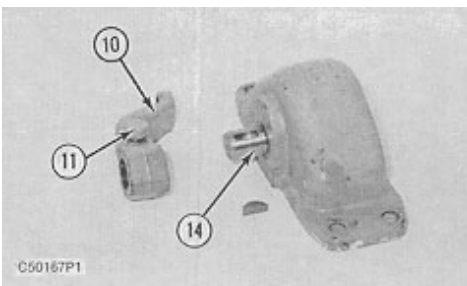

16. Install key in shaft (14). Install lever (11) on shaft (14). Tighten bolt (10).

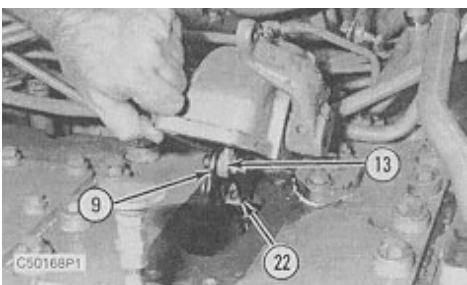

17. Put the brake housing in position as shown. Connect brake linkage (22) to lever (13) with pin and lock pin (9).

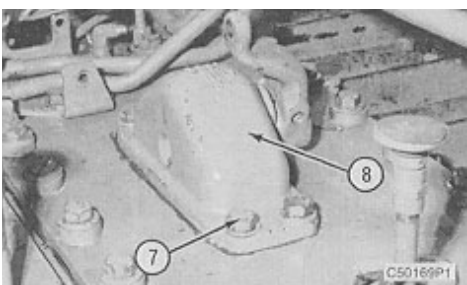

18. Put **3S6252 Sealant** between brake housing (8) and the cover. Put **9S3263 Thread Lock** on the threads of bolts (7), and install the bolts.

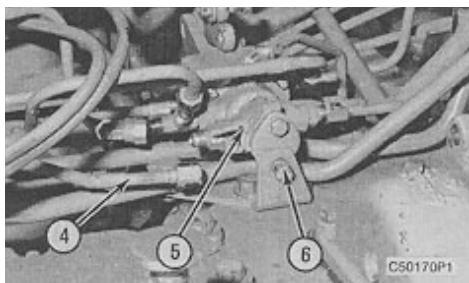

19. Put steering clutch control valve (5) in place on cover. Put **5P3413 Thread Sealant** on threads of bolts (6) and install three bolts.

20. Connect seven lines (4).

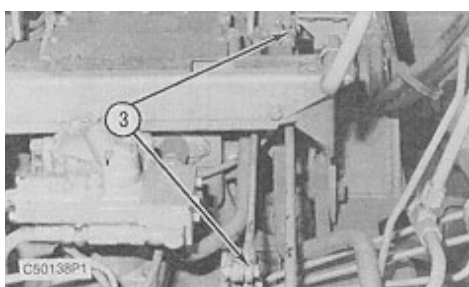

21. Connect linkage (3) to pedal assembly and steering control valve.

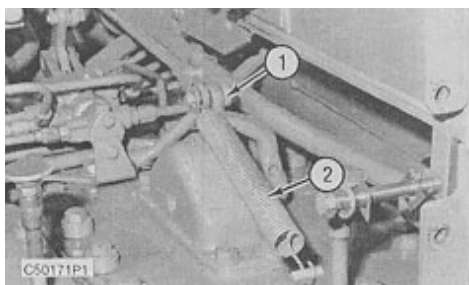

22. Install brake linkage (1) and spring (2).

23. Install the seat frame and seat.

24. Install the battery frame and battery.

25. Fill the steering clutch compartment with oil to the correct level. See the Operation And Maintenance Manual.

26. Check the steering clutches and brakes for correct adjustments. See the topics, Steering Clutch Adjustment and Brake adjustment in Specification.

27. Steps are the same for installation of both sides.

End By:

a. install fuel tank*

b. install hydraulic tank*

*These operations are in the Disassembly And Assembly Manual, machine systems, Form No. SENR5341.

Disassemble Steering Clutches

Tools Needed		A	B	C	D	E	F
3B3652	Wrench	1					
8B7548	Puller Assembly (Crossbar)		1	1	1		
3H465	Plate		2	4	2		
0L1329	Bolt		2				
1D4719	Nut		2				
5P4770	Spanner Wrench					1	
6V9061	Pump Group (or electric)			1	1		
1P520	Driver Group			1			
7S8431	Plate			1			
8B7549	Leg			2			
8B7556	Adapters			2			
8S7650	Cylinder Assembly			1			
7F9540	Puller Assembly				1		
1D4602	Bolt				2		
	Washer				2		
FT610	Clutch Stand						1

Tools Needed		G	H
8B7548	Puller Assembly (Crossbar)		1
3H465	Plate		2
0S1569	Bolt		2
5P9736	Link Bracket	2	

Start By:

a. remove steering clutches

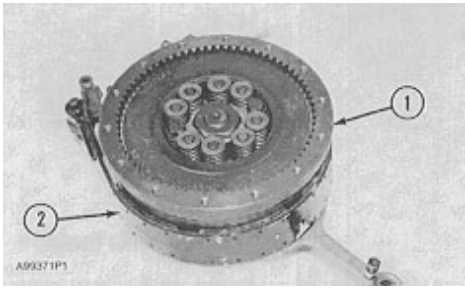

1. Remove brake band (2) and outer drum (1) from the steering clutch.

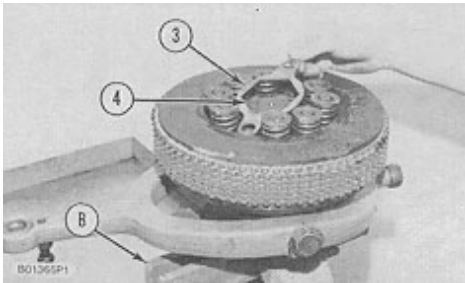

2. Install tooling (B) to the end of the clutch shaft and install it in a vise.

3. Remove lock (3). Use tooling (A) and loosen nut (4) until it is even with the top of the shaft.

 **WARNING**

Do not remove nut (4). This will keep the drum on the shaft when it is loosened from the taper on the shaft.

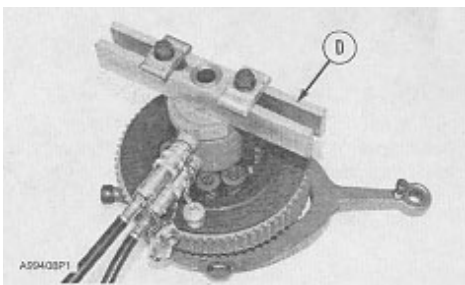

4. Remove the steering clutch from the vise. The weight is approximately **45 kg (100 lb)**.

5. Use tooling (D) as shown to push the shaft from the inner drum. Remove tooling (D) and nut (4). Remove the shaft from the steering clutch.

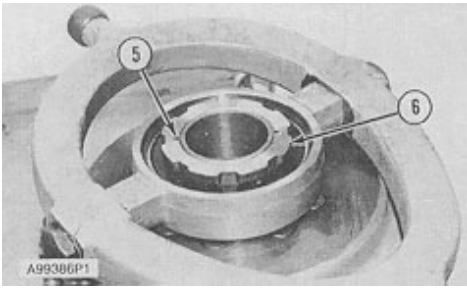

6. Install tooling (H) on the other side of the steering clutch and install it in a vise.
7. Remove two setscrews (5). Use tool (E) and remove spanner nut (6) from the plate assembly.

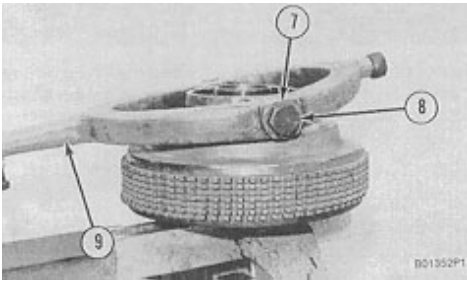

8. Bend locks (7) down and remove bolts (8) that hold the yoke in place.
9. Remove yoke (9) from the plate assembly.

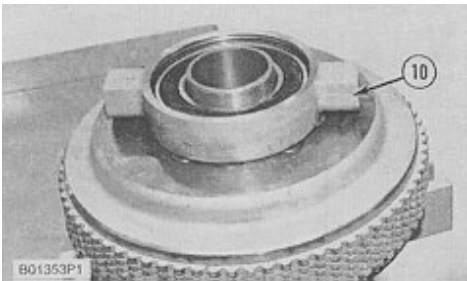

10. Use a pry bar on each side of the bearing cage and remove bearing cage (10) from the plate assembly.

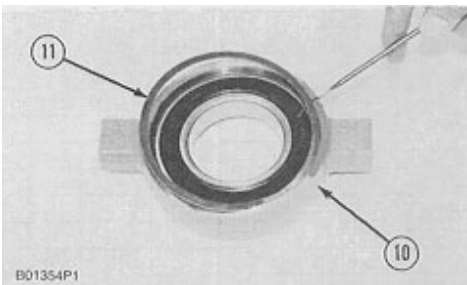

11. Remove retaining ring (11) from bearing cage (10).

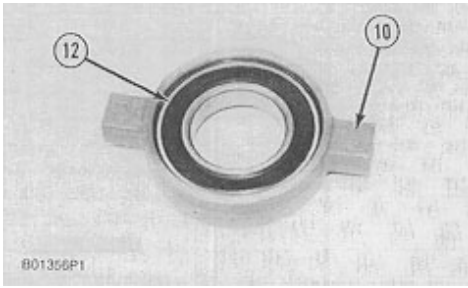

12. Remove bearing (12) from bearing cage (10).

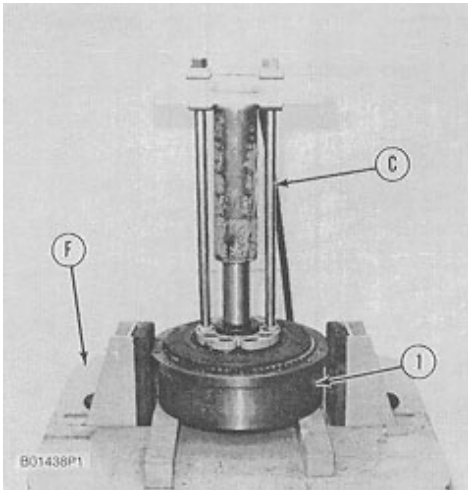

13. Put two pieces of wood (13) on tool (F), as shown, as a support for the steering clutches. Install drum (1). Make an alignment of the centers of the clutches and drum (1).

14. Install tooling (C), as shown, and put the steering clutch spring under compression.

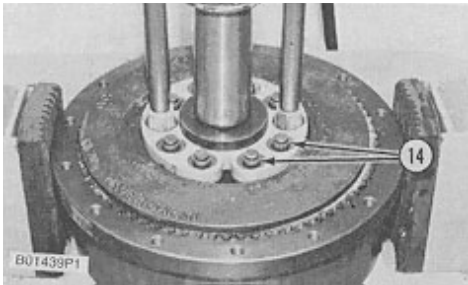

15. Remove locks (14) from the studs.

16. Slowly release the pressure on the steering clutch springs. Remove tooling (C).

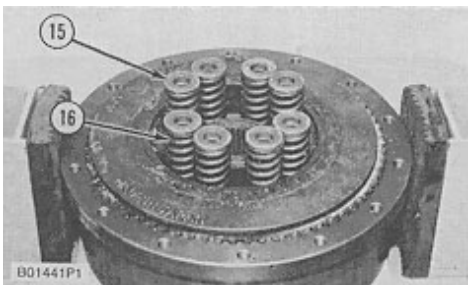

NOTE: Only oil-cooled steering clutches have spacers located under springs (16).

17. Remove retainers (15) springs (16) and the spacers from the studs.

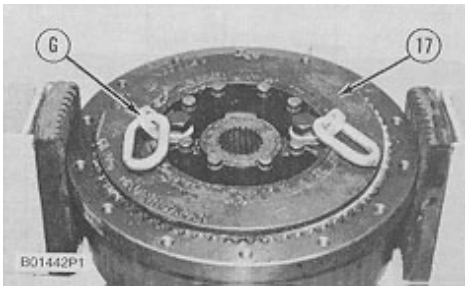

18. Install tooling (G) as shown. Fasten a hoist and remove inner drum (17).

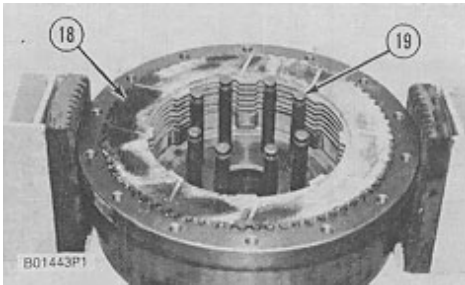

19. Remove steering clutch discs (18).

20. Remove studs (19) from the plate assembly.

Assemble Steering Clutches

Tools Needed		I	J	K	L	M	N	O
FT610	Clutch Stand	1						
5P9736	Link Bracket		2					
8B7548	Puller Assembly (Crossbar)			1		1	1	
6V9061	Pump Group (or electric)			1				1
1P520	Driver Group			1	1			
7S8431	Plate			1				
3H465	Plate			4		2	2	
8B7549	Leg			2				
8B7556	Adapter			2				
8S7650	Cylinder Assembly			1				
5P3036	Ring Installer			1				
0S1569	Bolt					2		
0L1329	Bolt						2	
1D4719	Nut						2	
7F9540	Puller Assembly							1
7M7237	Adapter							1
7M7238	Sleeve							1
2H0637	Bolt							1
	Washer							1

Tools Needed		P	Q
5P4770	Spanner Wrench	1	
3B6352	Wrench		1

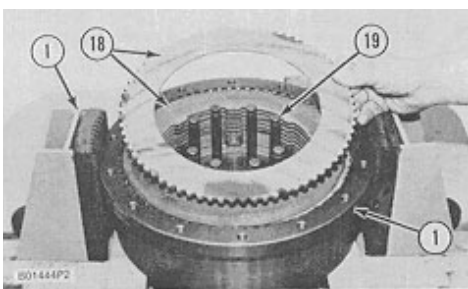

1. Install studs (19) in the plate assembly.
2. Put plate assembly and outer drum (1) in position on tool (I). Install steering clutch disc (18). Start and stop with a disc that has teeth on the outside diameter. Make a visual alignment of the inside diameter of the discs.

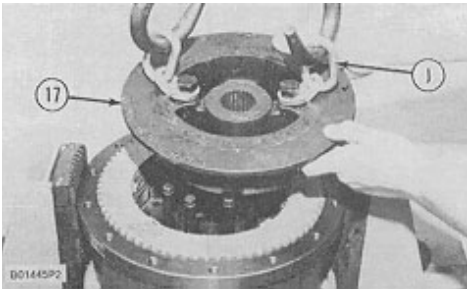

3. Install tooling (J) to inner drum (17) and fasten a hoist. Install inner drum (17).

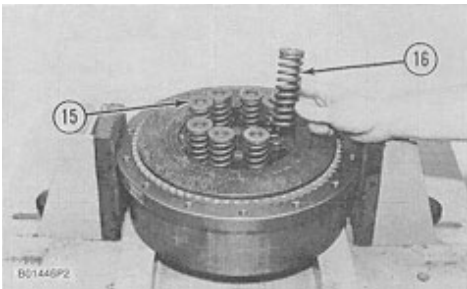

4. Install spacers, springs (16) and retainer (15) on studs.

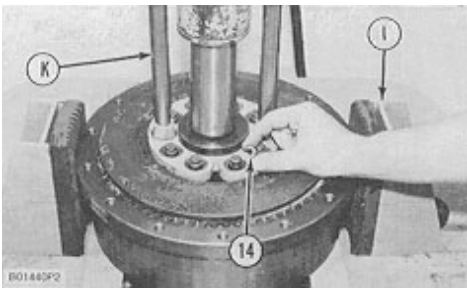

WARNING

Use only enough force to put the steering clutch springs under compression to install the locks on the studs. Be extra careful that 5P3036 Installer Ring moves freely on the studs.

5. Install tooling (K) and put springs (16) under compression. Install locks (14) on the studs.

6. Remove tooling (K). Remove the steering clutch from tool (I). Remove outer drum (10).

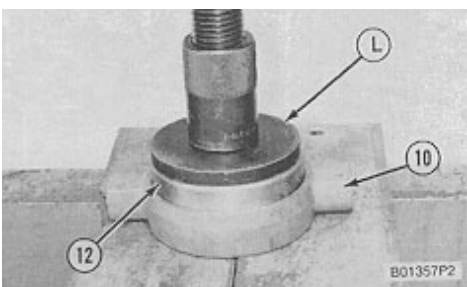

7. Install bearing (12) in bearing cage (10) with tooling (L).

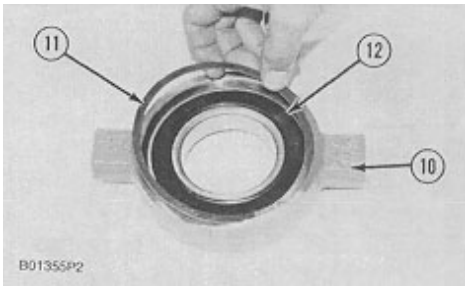

8. Install retaining ring (11) that holds bearing (12) in bearing cage (10).

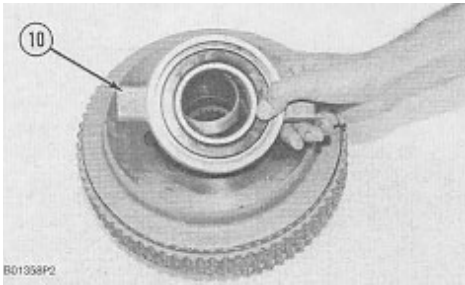

9. Install bearing cage (10) on plate assembly.

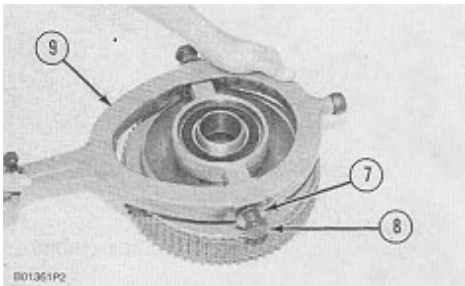

10. Put yoke (9) on the bearing cage.

11. Install locks (7) and bolts (8) that hold the yoke to the bearing cage. Bend the locks up.

12. Install tooling (M) on the steering clutch inner drum, and put it in a vise.



Suggest:

If the above button click is invalid.

Please download this document

first, and then click the above link

to download the complete manual.

Thank you so much for reading

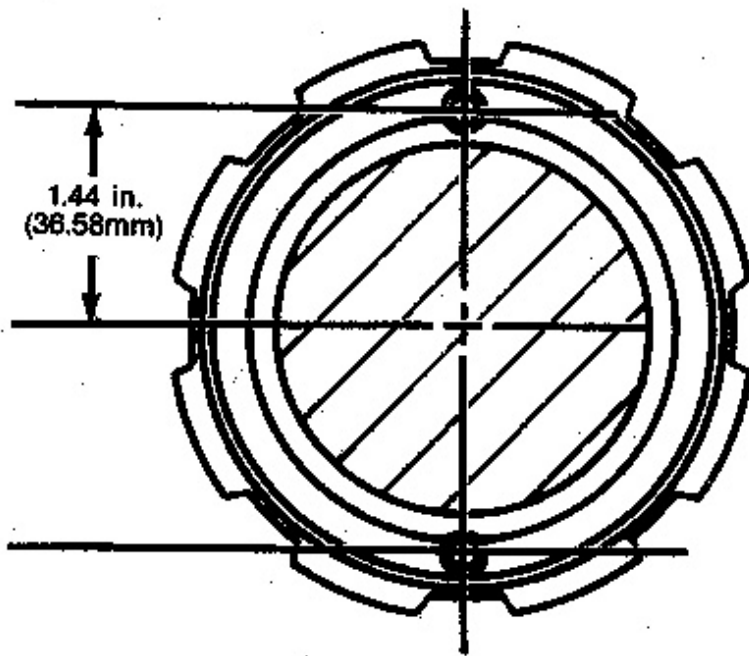

A99545P1

12. If a replacement spanner nut is needed, drill two holes **5.16 mm (.203 in)** to a depth of **9.65 mm (.38 in)** with the center line of the spanner nut to the holes **36.58 mm (1.44 in)** apart as shown. Use a **1/4 " - 20 NC tap** to make threads in the spanner nut to a depth of **7.87 mm (.31 in)**.

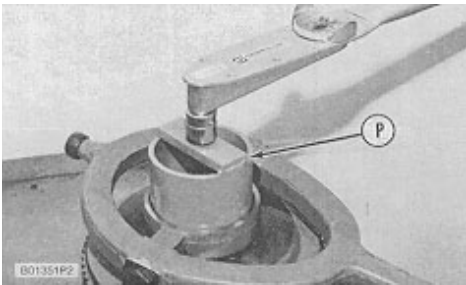

13. Use tool (P) and install spanner nut (6). Tighten the spanner nut to a torque of a **470 ± 70 N·m (350 ± 50 lb ft)**.

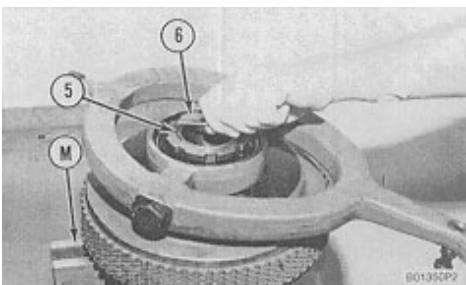

14. Install setscrews (5) that lock the spanner nut (6) in place.

15. Use a center punch to move the metal stake over the setscrews enough to keep the setscrews tight.

16. Remove the steering clutch from the vise. Remove tooling (M).

<https://www.ebooklibonline.com>

Hello dear friend!

Thank you very much for reading.

Enter the link into your browser.

The full manual is available for immediate download.

<https://www.ebooklibonline.com>