



# Service Repair Manual

## **Models**

326F, 326F L and 326F LN  
Excavator

---

[Previous Screen](#)

Product: EXCAVATOR

Model: 326F EXCAVATOR GGJ

Configuration: 326F L &amp; 326F LN Excavators GGJ00001-UP (MACHINE) POWERED BY C7.1 Engine

## Disassembly and Assembly 326F, 329F and 330F Excavators Machine Systems

Media Number -UENR3313-07

Publication Date -01/09/2015

Date Updated -12/09/2018

i05435999

# Travel Motor - Assemble

SMCS - 4351-016

## Assembly Procedure

Table 1

Required Tools			
Tool	Part Number	Part Description	Qty
A	1U-7506	Adapter	1
	8T-4244	Nut	6
	8T-4223	Hard Washer	6
	-	M12 x 1.75 X 250 mm (10 inch) Threaded Rod	1
C	3E-3882	Eyebolt	1
D	1P-1859	Retaining Ring Pliers	1
E	1P-0510	Driver Gp	1
	9S-9152	Bearing Puller Gp	1
F	1P-1861	Retaining Ring Pliers	1
G	-	Loctite 242	-



Illustration 1

g00887762

1. Install O-ring seal (35) onto the housing of the travel motor.



Illustration 2

g00887754

2. Install seal (34) and piston actuator (33). Lubricate the surfaces of piston actuator (33) with lubricant that is being sealed.



Illustration 3

g00887729

3. Install backup ring (32) and seal (31).

**<https://www.ebooklibonline.com>**

Hello dear friend!

Thank you very much for reading.

Enter the link into your browser.

The full manual is available for immediate download.

**<https://www.ebooklibonline.com>**

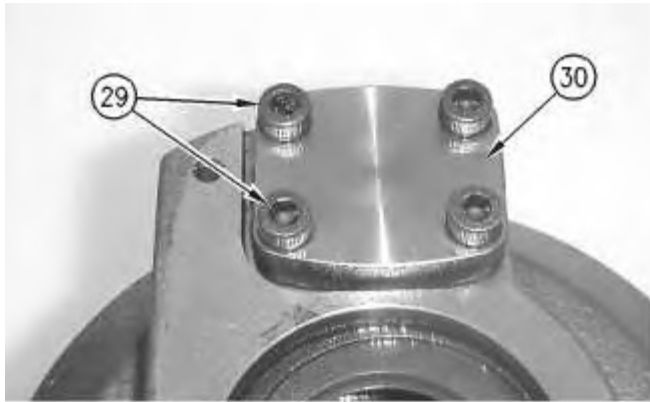

Illustration 4

g00887619

4. Install cover (30) and bolts (29). Tighten bolts (29) to a torque of  $28 \pm 7$  N·m ( $21 \pm 5$  lb ft).



Illustration 5

g00887589

5. Apply Tooling (G) to the mating surface of lip seal (28). Use Tooling (E) in order to install lip seal (28). Lubricate the sealing lip of lip seal (28) with lubricant that is being sealed.
6. Use Tooling (F) in order to install retaining ring (27).

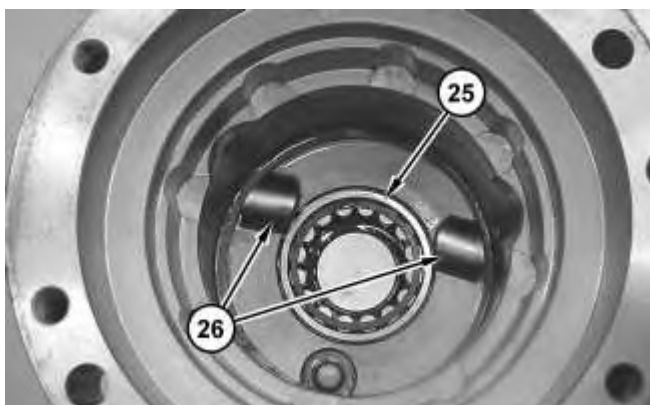

Illustration 6

g02107975

7. Rotate the housing.

8. Install keys (26) and locating pins (not shown) into the body of the travel motor.
9. Install bearing (25).



Illustration 7

g00887558

 **WARNING**

**Improper assembly of parts that are spring loaded can cause bodily injury.**

**To prevent possible injury, follow the established assembly procedure and wear protective equipment.**

---

10. Install springs (24) into the barrel assembly. Install ball (23) onto springs (24). Lubricate ball (23) with lubricant that is being sealed.



Illustration 8

g00887520

11. Lubricate the piston assemblies with lubricant that is being sealed. Install piston assemblies and retainer plate (22) into barrel assembly (21).

**Note:** Take note of the mark on the piston assembly and the barrel assembly. The pistons must be returned to the same position.

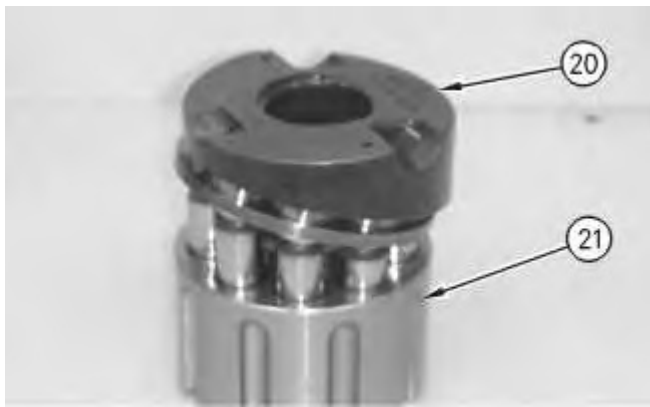

Illustration 9

g00887501

12. Lubricate cam plate (20) with lubricant that is being sealed. Install cam plate (20) onto barrel assembly (21).

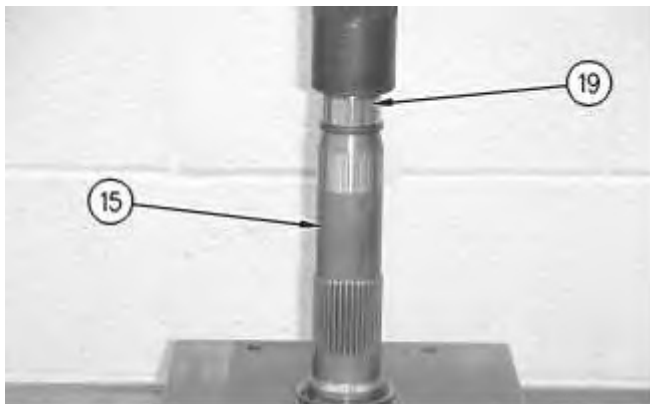

Illustration 10

g00888697

13. Install shaft (15) into a suitable press. Install bearing race (17) onto shaft (15).



Illustration 11

g00887426

14. Rotate shaft (15) in the suitable press. Use Tooling (D) to install retaining ring (17) onto shaft (15).

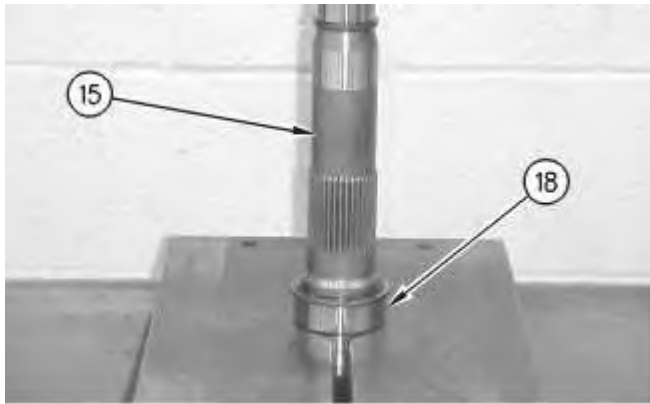

Illustration 12

g00888710

15. Install bearing race (18) onto shaft (15).

**Note:** Bearing race (18) must contact retaining ring (17).

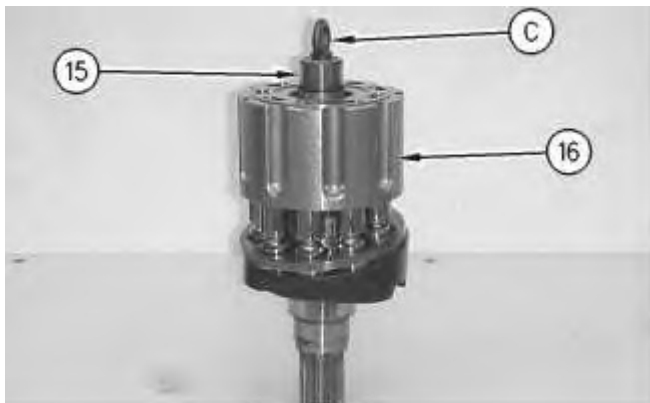

Illustration 13

g00887405

16. Install Tooling (C) into shaft (15). Install shaft (15) into rotating assembly (16).

17. Place the pump housing into Tooling (A).



18. Use Tooling (C) in order to install rotating assembly (16) into the housing.



---

Illustration 15

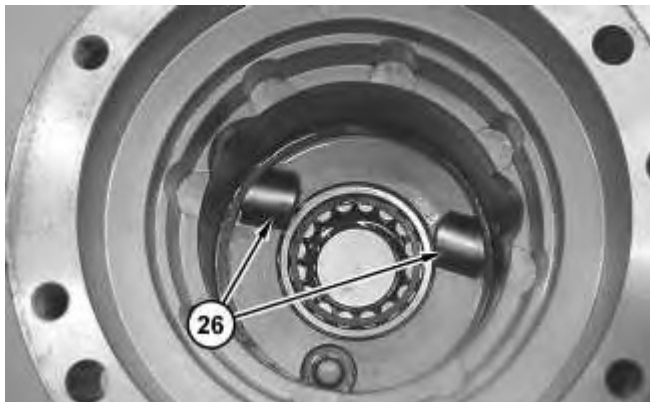

---

Illustration 16

19. The notches in cam plate (20) must align with keys (26). The keys (26) are located in the bottom of the housing of the travel motor.

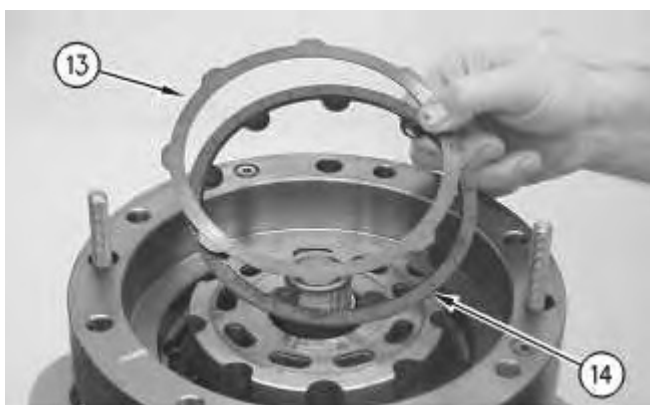

---

Illustration 17

20. Install plates (13) and friction discs (14) into the housing.

**Note:** Install the plates and the discs alternately.



Illustration 18

g00887336

21. Install backup ring (12) and seal (11) onto the brake piston.

22. Install backup ring (10) and seal (9) onto the brake piston.

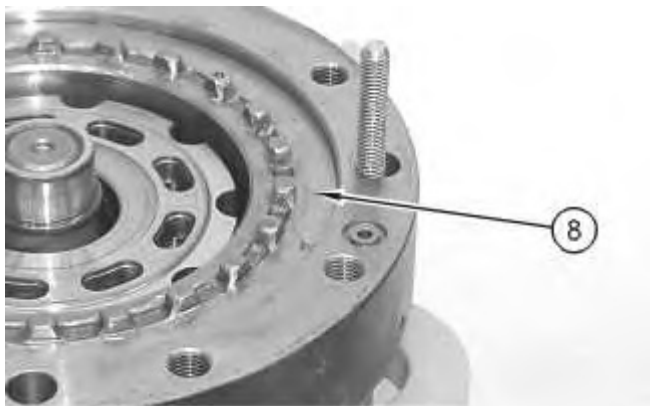

Illustration 19

g00888967

23. Rotate brake piston (8).

24. Install brake piston (8) into the housing.

**Note:** Brake piston (8) must be level upon installation. The brake piston must be level in order to prevent damage to the O-ring seals.

---

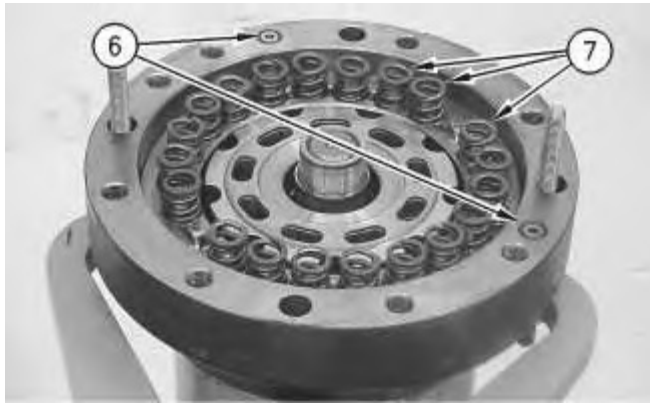

Illustration 20

g00887311

25. Install springs (7) and O-ring seals (6).

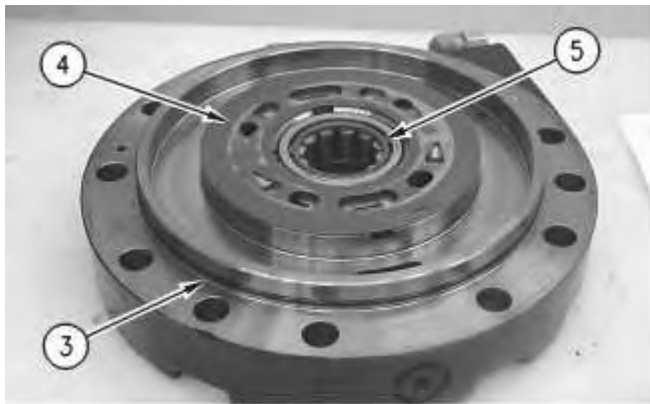

Illustration 21

g00887302

26. Lubricate port plate (4) with lubricant that is being sealed. Install O-ring seal (3), port plate (4), and bearing (5).



Illustration 22

g00887295

 **WARNING**

**Improper assembly of parts that are spring loaded can cause bodily injury.**

**To prevent possible injury, follow the established assembly procedure and wear protective equipment.**

---

27. Install head (2) onto the body of the travel motor.

**Note:** During the installation of head (2) onto the travel motor, be careful not to damage the mating surfaces of the components.

28. Install bolts (1). Tighten bolts (1) to a torque of  $177 \pm 18 \text{ N}\cdot\text{m}$  ( $131 \pm 13 \text{ lb ft}$ ).

**End By:**

a. Install the travel motor.

[Previous Screen](#)

Product: EXCAVATOR

Model: 326F EXCAVATOR GGJ

Configuration: 326F L &amp; 326F LN Excavators GGJ00001-UP (MACHINE) POWERED BY C7.1 Engine

## **Disassembly and Assembly 326F, 329F and 330F Excavators Machine Systems**

Media Number -UENR3313-07

Publication Date -01/09/2015

Date Updated -12/09/2018

i07505850

### **Travel Motor - Assemble**

SMCS - 4351-016

S/N - B321-UP

S/N - EBK1-UP

S/N - ERL1-UP

S/N - FBR1-UP

S/N - GGJ1-UP

S/N - GHT1-UP

S/N - HBT1-UP

S/N - HCA1-UP

S/N - HCJ1-UP

S/N - HCK1-UP

S/N - JFR1-UP

S/N - JHF1-UP

S/N - KFA1-UP

S/N - LBN1-UP

S/N - LCG1-UP

S/N - MBX1-UP

S/N - RCN1-UP

S/N - TMR1-UP

S/N - TPG1-UP

S/N - WBA1-UP

S/N - WGL1-UP

S/N - XFK1-UP

S/N - YHA1-UP

## Assembly Procedure

Table 1

Required Tools			
Tool	Part Number	Part Description	Qty
A	1P-2420	Transmission Repair Stand	1
	FT-0957	Positioning Gp	4
B	-	M16x2 Threaded Rod	3
	8T-1757	Nut	6
	9X-8268	Washer	6
C	421-5662	Lifting Eye Assembly	1
D	421-5663	Lifting Eye Assembly	2



Illustration 1

g06343795

1. Install lip seal (45) and bearing (44).
2. Install balls (46).



Illustration 2

g06343793



Illustration 3

g06343788

3. Install shaft (43) and springs (42).
4. Install pistons (41).



Illustration 4

g06343786

5. Install swashplate (40) into housing (26).
-



---

Illustration 5

g06343783

6. Install springs (39) and hold down ball (38) into barrel (37).



---

Illustration 6

g06343777

7. Install retainer (36) and piston (35) into barrel (37).



---

Illustration 7

g06343638

8. Install rotating group (34) into housing (26).
-



---

Illustration 8

g06343469

---



---

Illustration 9

g06343466

---

9. Install plates (33) and friction discs (32) in the orientation determined in the disassembly.
- 



---

Illustration 10

g06343464

---

10. Install O-ring seal (31) into brake piston guide (30).
-



Illustration 11

g06343462

11. Install brake piston guide (30).



Illustration 12

g06343437

12. Install O-ring seals (29) and back up rings (28) into brake piston (27).

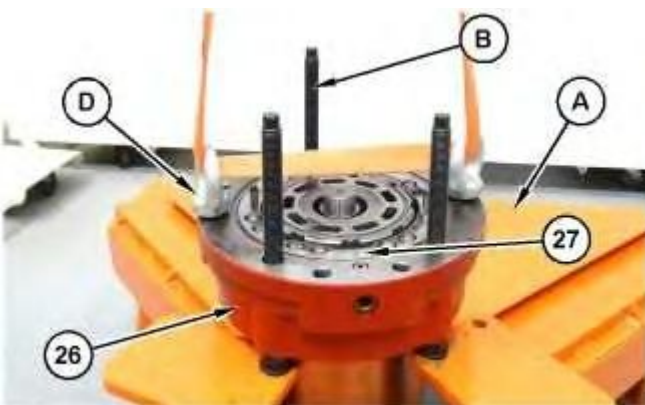

Illustration 13

g06343877

13. Use Tooling (D) and a suitable lifting device to position housing (26) onto Tooling (A) and (B). The weight of housing (26) is approximately 43 kg (95 lb).
14. Remove Tooling (D) and install brake piston (27).



Illustration 14

g06343381

15. Install O-ring seals (25) and (24).
16. Install springs (23) and pins (22).



Illustration 15

g06343374

17. Install bearing (21) and control plate (20) into head assembly (18).

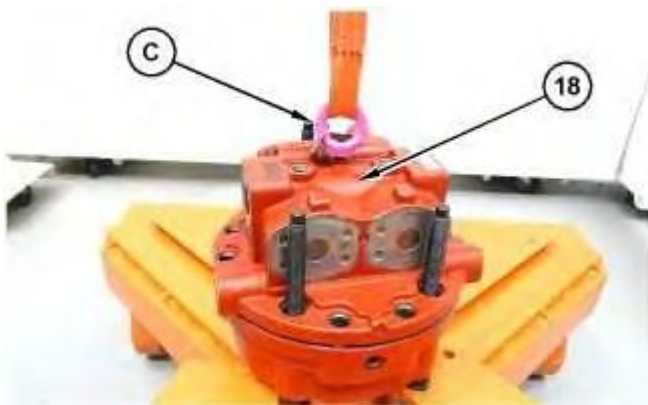

Illustration 16

g06343366

18. Use Tooling (C) and a suitable lifting device to install head assembly (18) onto the housing. The weight of head assembly (18) is approximately 21 kg (47 lb).

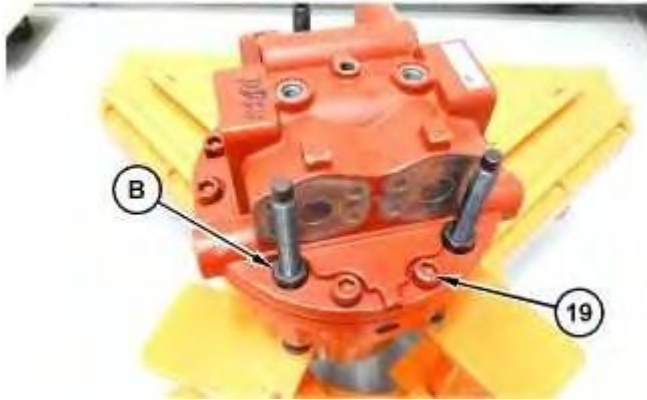

Illustration 17

g06343887

 **WARNING**

**Improper assembly of parts that are spring loaded can cause bodily injury.**

**To prevent possible injury, follow the established assembly procedure and wear protective equipment.**

19. Install bolts (19). Tighten bolts (19) to a torque of  $205 \pm 10 \text{ N}\cdot\text{m}$  ( $151 \pm 7 \text{ lb ft}$ ).
20. Install the bolts of Tooling (B)



Illustration 18

g06343315



Illustration 19

g06343314

21. Install O-ring seal (17) onto relief valve (16).
22. Install relief valve (16) into the head assembly. Tighten relief valve (16) to a torque of  $570 \pm 20 \text{ N}\cdot\text{m}$  ( $420 \pm 14 \text{ lb ft}$ ). Repeat for the opposite side.



Illustration 20

g06342009

23. Install spool (15).

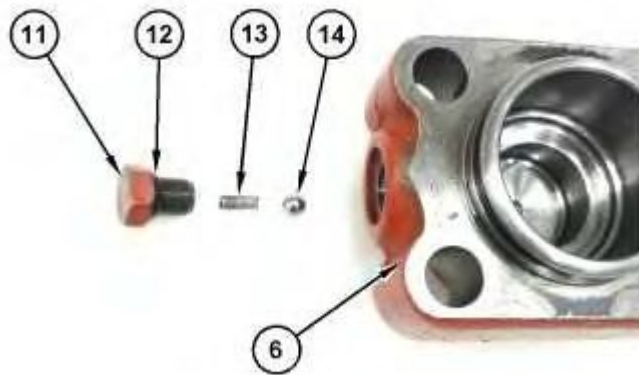

Illustration 21

g06342005

**! WARNING**

**Improper assembly of parts that are spring loaded can cause bodily injury.**

**To prevent possible injury, follow the established assembly procedure and wear protective equipment.**

---

- 24. Install O-ring seal (12) onto plug (11).
- 25. Install ball (14), spring (13), and plug (11) into cap (6). Repeat for the opposite side.

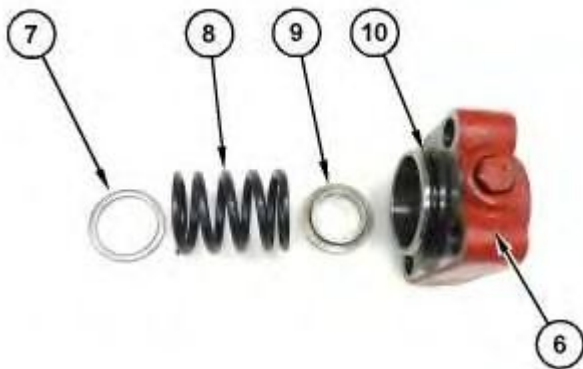

Illustration 22

g06342000

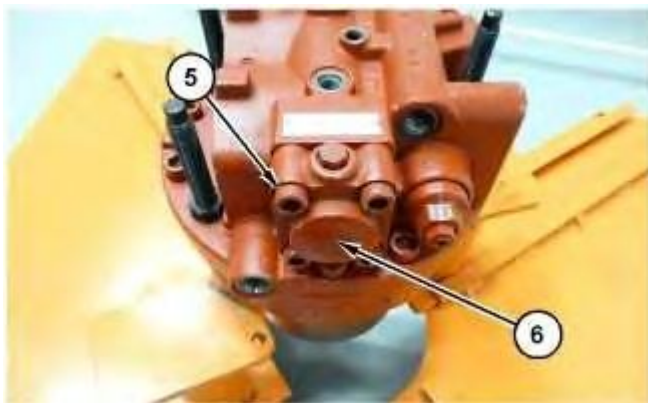

Illustration 23

g06341942

**! WARNING**

**Improper assembly of parts that are spring loaded can cause bodily injury.**

**To prevent possible injury, follow the established assembly procedure and wear protective equipment.**

---

26. Install O-ring seal (10) onto cap (6).
27. Install washer (7), spring (8), guide (9), and cap (6) into the head assembly.
28. Repeat for the opposite side.



Illustration 24

g06341917

29. Install spool (4).



Illustration 25

g06341915

30. Install spring (3).
-



**Suggest:**

**If the above button click is invalid.**

**Please download this document**

**first, and then click the above link**

**to download the complete manual.**

**Thank you so much for reading**

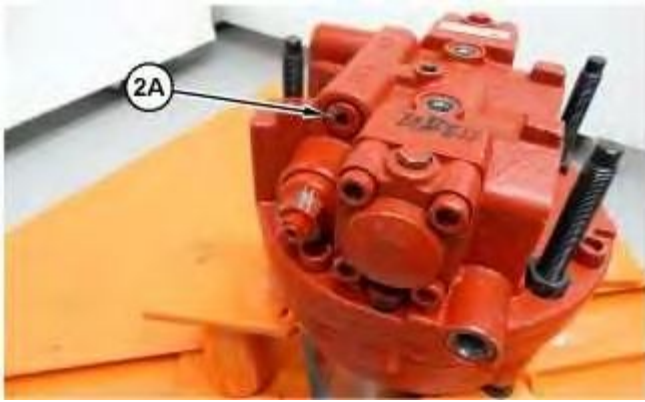

Illustration 26

g06341912

**! WARNING**

**Improper assembly of parts that are spring loaded can cause bodily injury.**

**To prevent possible injury, follow the established assembly procedure and wear protective equipment.**

31. Install plug (2A). Tighten plug (2A) to a torque of  $54 \pm 5$  N·m ( $40 \pm 4$  lb ft). Repeat for the opposite side.



Illustration 27

g06344110

32. Install plug (2) and the O-ring seal. Tighten plug (2) to a torque of  $53 \pm 2$  N·m ( $39 \pm 1$  lb ft).

**<https://www.ebooklibonline.com>**

Hello dear friend!

Thank you very much for reading.

Enter the link into your browser.

The full manual is available for immediate download.

**<https://www.ebooklibonline.com>**