



Service Repair Manual

Models

325B L EXCAVATOR

[Previous Screen](#)

Product: EXCAVATOR

Model: 325B L EXCAVATOR 1GS

Configuration: 325B L TRACK-TYPE EXCAVATOR /HAMMER ARRANGEMENT/ 1GS00001-UP (MACHINE) POWERED BY 3116 ENGINE

Disassembly and Assembly 325B Excavator Machine Systems

Media Number -SEN8963-06

Publication Date -01/02/2017

Date Updated -21/02/2017

i02202099

Final Drive - Disassemble

SMCS - 4050-015

Disassembly Procedure

Table 1

Required Tools			
Tool	Part Number	Part Description	Qty
A	1P-2420	Transmission Repair Stand	1
B	138-7573	Link Bracket	2
C	1P-1860	Retaining Ring Pliers	1
D	6B-6682	Full Nut	1
	1P-5546	Crossblock	1
	5P-8248	Hard Washer	4
	6V-3142	Puller Plate	1
		⁽¹⁾ Threaded Rod	1
		⁽²⁾ Spacer	4
E	138-7574	Link Bracket	2
F	8B-7561	Step Plate	1
	5F-7465	Puller Assembly	1
	1H-3107	Bearing Puller Assembly	1
	1H-3112	Bearing Puller Assembly	1
	1P-5551	Screw Assembly	1

⁽¹⁾ The 16 NF threaded rod is 280 mm (11 inch) long × 19 mm (0.75 inch) in diameter.

⁽²⁾

The spacer's outer diameter is 64 mm (2.5 inch). The spacer's inner diameter is 25.4 mm (1.0 inch). The spacer's thickness is 6.4 mm (.25 inch).

Start By:

- a. Remove the final drive. Refer to Disassembly and Assembly, "Final Drive - Remove" in this manual.
1. Thoroughly clean the outside of the final drive prior to disassembly.
2. Put an alignment mark across the sections of the final drive for assembly purposes. The parts must be reinstalled in the part's original locations.

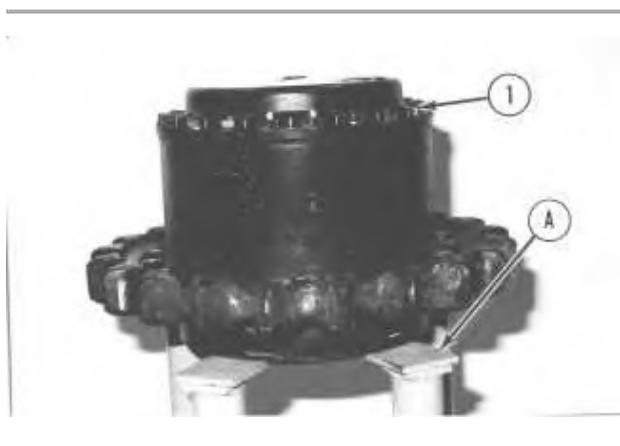

Illustration 1

g00511587

3. Fasten the final drive to Tooling (A), as shown. The combined weight of the final drive and final drive sprocket is approximately 361 kg (795 lb).
4. Remove bolts (1) and the washers that hold the cover in position.

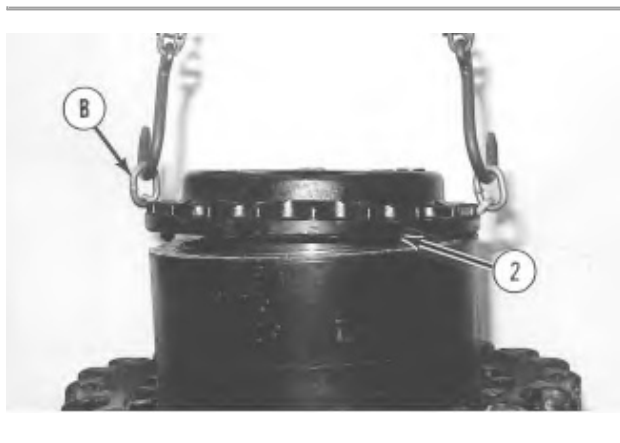

Illustration 2

g00511600

5. Use a soft hammer and break the seal between cover (2) and the ring gear. Fasten Tooling (B) and a suitable lifting device to cover (2), as shown. Remove cover (2). The weight of cover (2) is approximately 32 kg (70 lb).
-

<https://www.ebooklibonline.com>

Hello dear friend!

Thank you very much for reading.

Enter the link into your browser.

The full manual is available for immediate download.

<https://www.ebooklibonline.com>



Illustration 3

g00511631

6. Remove thrust plate (5) from the cover.
 7. Remove socket head bolts (3) and ring gear (4) from the cover.
-

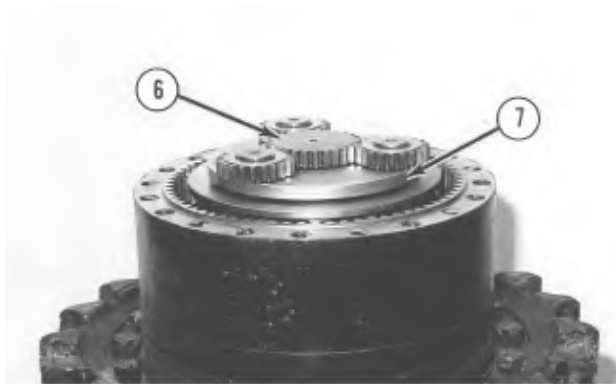

Illustration 4

g00511636

8. Remove sun gear (6). Remove carrier assembly (7) by lifting the carrier assembly straight up. The weight of carrier assembly (7) is approximately 14 kg (30 lb).
-

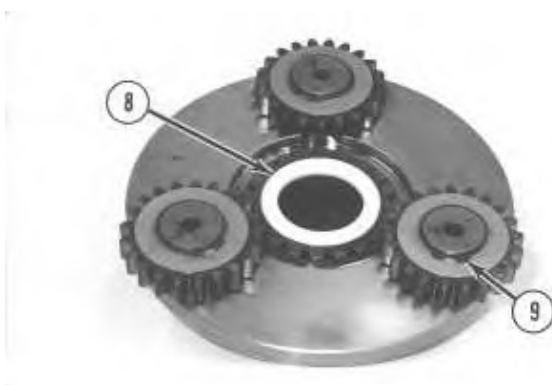

Illustration 5

g00511640

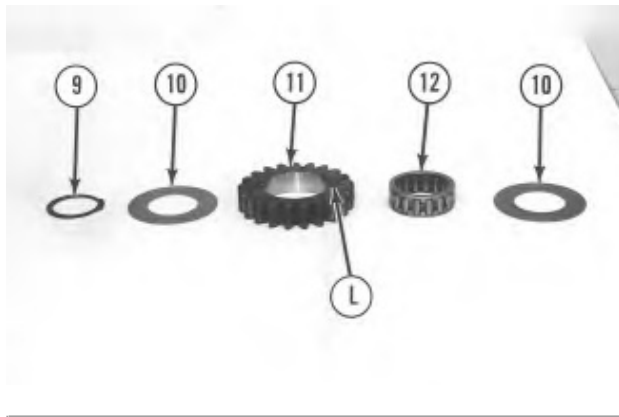

Illustration 6

g00572334

Note: Two spacers (8) are used with carrier assembly (7). One spacer (8) fits on the top side of carrier assembly (7). The other spacer (8) is located in carrier assembly (15).

9. Remove spacer (8) from carrier assembly (7).

Note: Planetary gears (11) might have oil grooves "L". Note the position of the oil grooves in relation to the carrier for assembly purposes.

10. Use Tooling (C) in order to remove retaining ring (9). Remove thrust washers (10) and planetary gear (11) from the carrier. Remove bearing (12) from the planetary gear.
11. Repeat Step 10 in order to remove the remaining planetary gears from the carrier.

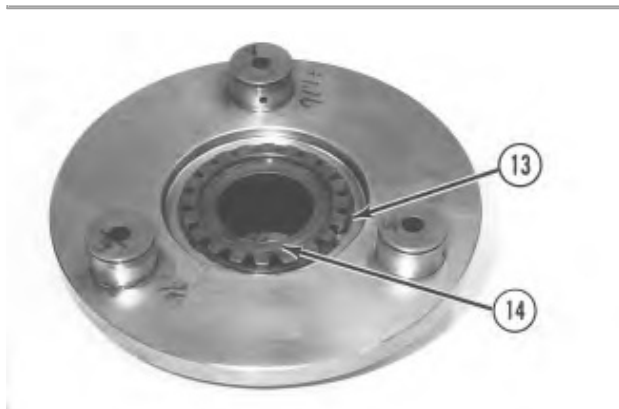

Illustration 7

g00511653

12. Use a screwdriver and remove retaining ring (13) from the carrier. Remove sun gear (14) from the carrier.

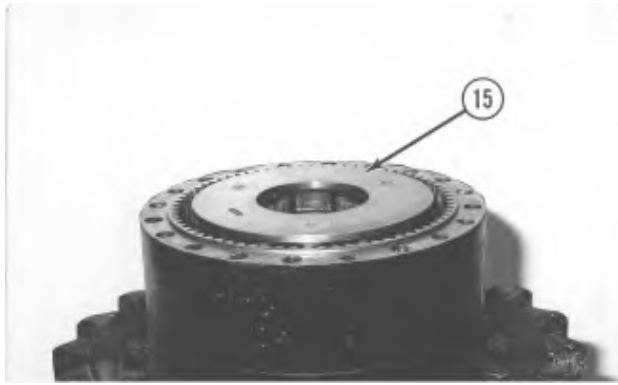

Illustration 8

g00511661

13. Use two people in order to remove carrier assembly (15). Remove the carrier assembly (15) by pulling carrier assembly (15) straight up. The weight of carrier assembly (15) is approximately 25 kg (55 lb).

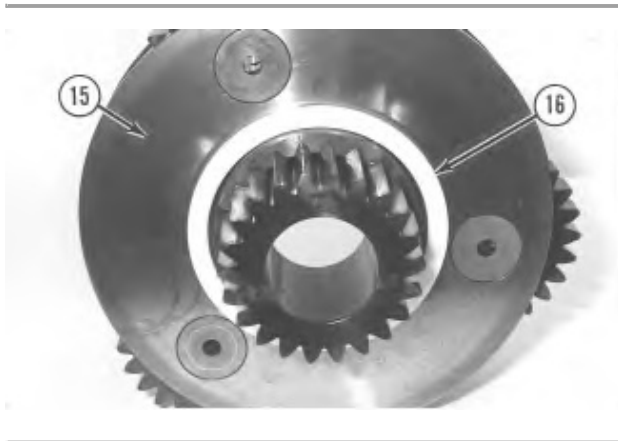

Illustration 9

g00511682

Note: Spacer (16) may remain with carrier assembly (15), or spacer (16) may remain with carrier assembly (24). Refer to Step 19.

14. Remove the other spacer (8) (not shown) from the top side of carrier assembly (15). Remove spacer (16) from the bottom side of carrier assembly (15).

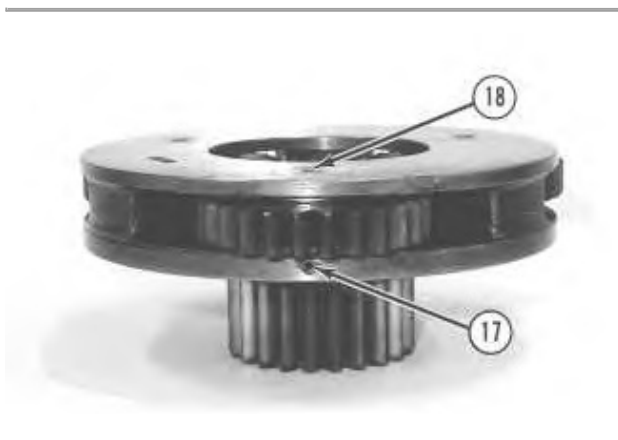

Illustration 10

g00511735

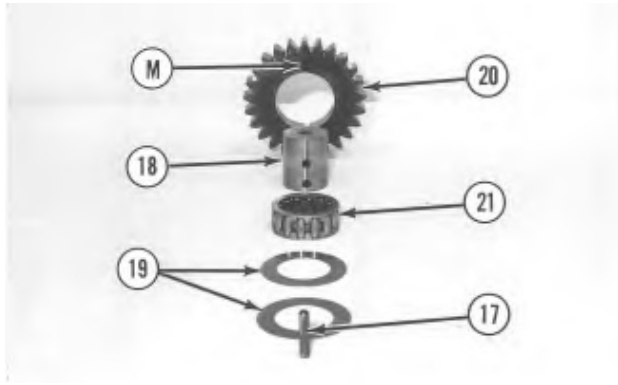

Illustration 11

g00572352

15. Drive spring pin (17) into planetary shaft (18) with a hammer and a punch.

Note: Planetary gears (20) might have oil grooves "M". Note the position of the oil grooves in relation to the carrier for assembly purposes.

16. Remove planetary shaft (18), thrust washers (19) and planetary gear (20) from the carrier.
Remove bearing (21) from the planetary gear. Remove spring pin (17) from planetary shaft (18) with a hammer and a punch.
17. Repeat Steps 15 and 16 in order to remove the remaining planetary gears from the carrier.



Illustration 12

g00511788

18. Use a screwdriver and remove retaining ring (22). Remove sun gear (23) from the carrier.



Illustration 13

g00511795

19. If spacer (16) was not removed in Step 14, remove spacer (16) from carrier assembly (24) at this time.
20. Slide a piece of steel bar stock between the planetary gears in carrier assembly (24), as shown. Make sure that the bar stock is centered in carrier assembly (24). Fasten a suitable lifting device to the steel bar stock, as shown. Slowly lift carrier assembly (24) from the final drive. The weight of carrier assembly (24) is approximately 36 kg (80 lb).

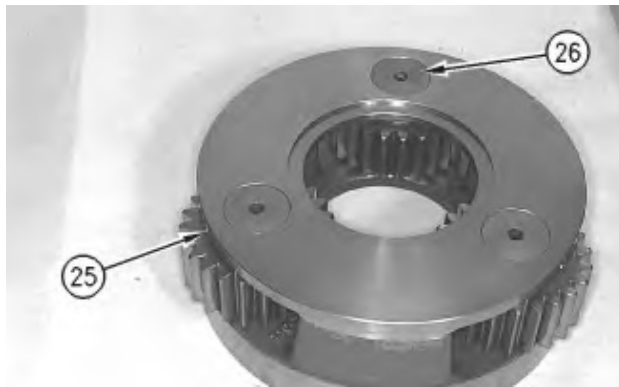

Illustration 14

g00511799

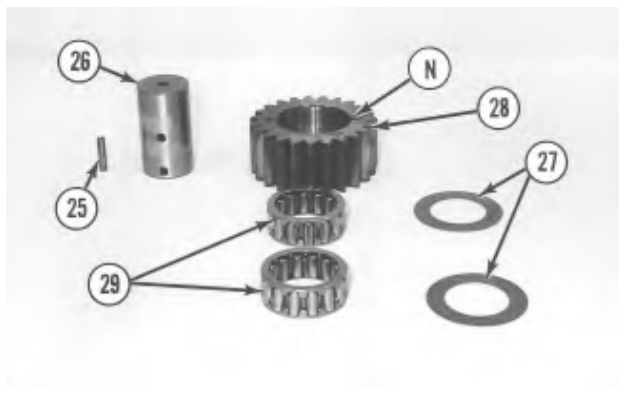

Illustration 15

g00572382

21. Drive spring pin (25) into planetary shaft (26) with a hammer and a punch.
Note: Planetary gears (28) might have oil grooves "N". Note the position of the oil grooves in relation to the carrier for assembly purposes.
 22. Remove planetary shaft (26), thrust washers (27) and planetary gear (28) from the carrier. Remove bearings (29) from the planetary gear (28). Drive spring pin (25) out of planetary shaft (26) with a hammer and a punch.
 23. Repeat Steps 21 and 22 in order to remove the remaining planetary gears from the carrier.
-

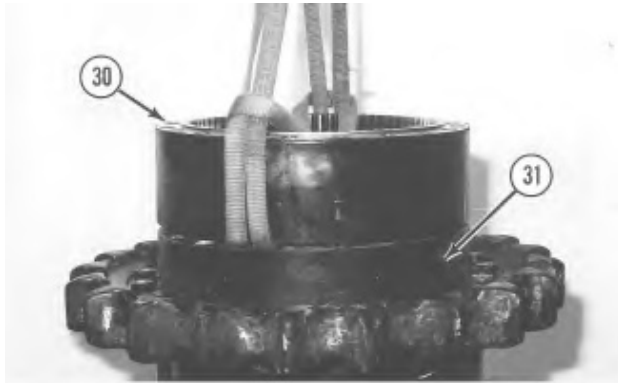

Illustration 16

g00511809

Note: It will be necessary to pry ring gear (30) away from main housing (31) in order to install the lifting slings.

24. Fasten a suitable lifting device to ring gear (30), as shown. Remove the ring gear from main housing (31). The weight of ring gear (30) is approximately 48 kg (105 lb).

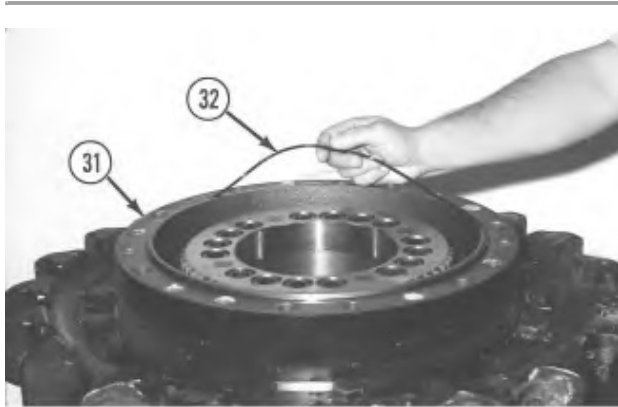

Illustration 17

g00511825

25. Remove O-ring seal (32) from main housing (31).



Illustration 18

g00511857

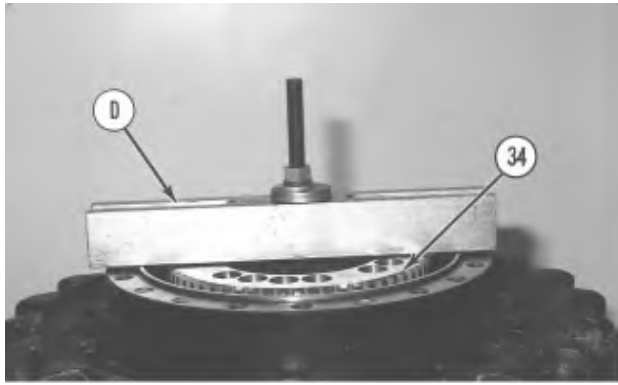

Illustration 19

g00511869

26. Remove socket head bolts (33) from gear (34).
27. Use Tooling (D) to remove gear (34) from the housing.



Illustration 20

g00511872

28. Remove shims (35) from the housing.

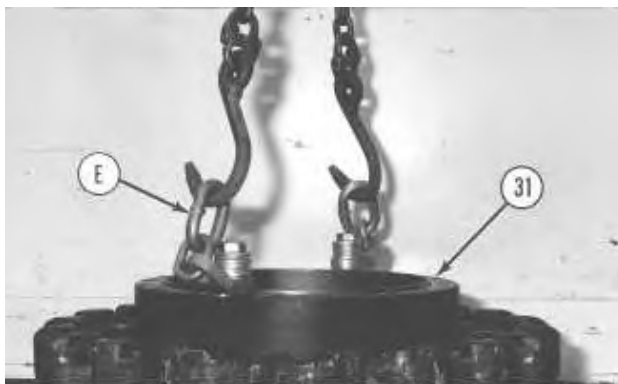

Illustration 21

g00511882

29. Fasten Tooling (E) and a suitable lifting device to main housing (31), as shown. Separate the main housing and the final drive sprocket from the motor housing. The combined weight of main housing (31) and the final drive sprocket is approximately 82 kg (180 lb).



Illustration 22

g00511906

30. Remove Duo-Cone seal (36) from the motor housing.

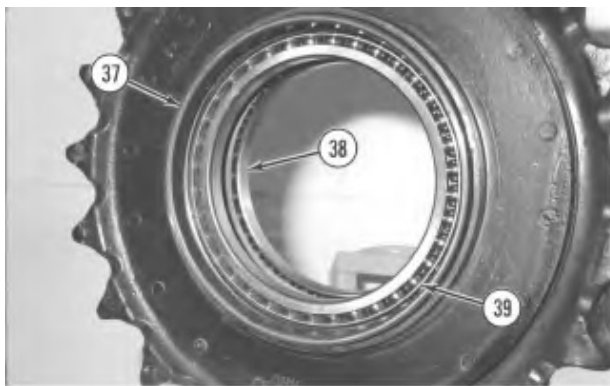

Illustration 23

g00511934

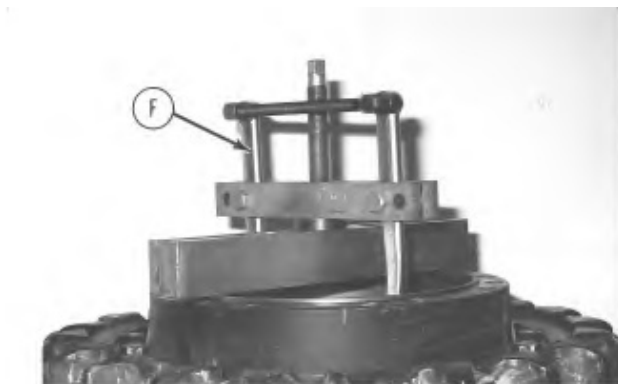

Illustration 24

g00511939

31. Remove Duo-Cone seal (37) from the main housing.
32. Use Tooling (F) to remove bearings (38) and (39) from the main housing.
33. If necessary, remove the final drive sprocket from the main housing. Refer to Disassembly and Assembly, "Final Drive Sprocket - Remove and Install" for the removal of the final drive sprocket from the main housing.

[Previous Screen](#)

Product: EXCAVATOR

Model: 325B L EXCAVATOR 1GS

Configuration: 325B L TRACK-TYPE EXCAVATOR /HAMMER ARRANGEMENT/ 1GS00001-UP (MACHINE) POWERED BY 3116 ENGINE

Disassembly and Assembly 325B Excavator Machine Systems

Media Number -SEN8963-06

Publication Date -01/02/2017

Date Updated -21/02/2017

i02201834

Final Drive - Assemble

SMCS - 4050-016

Assembly procedure

Table 1

Required Tools			
Tool	Part Number	Part Description	Qty
A	1P-2420	Transmission Repair Stand	1
B	138-7573	Link Bracket	2
C	1P-1860	Retaining Ring Pliers	1
D	1U-5933	Seal Installer	1
E	138-7574	Link Bracket	2
F	5P-3931	Anti-Seize Compound	1
G	9S-3263	Thread Lock Compound	1
H	1U-8846	Gasket Sealant	1

Note: Make sure that all of the parts of the final drive are thoroughly clean and free of dirt and debris prior to assembly.

1. Check the condition of all the O-ring seals that are used in the final drive. If any of the O-ring seals are damaged, use new parts for replacement.

Note: If the final drive sprocket was removed from the main housing, refer to Disassembly and Assembly, "Final Drive Sprocket - Remove and Install" in this manual. Follow the installation procedure in order to install the final drive sprocket on the main housing.

2. Assemble the final drive on Tooling (A).
-

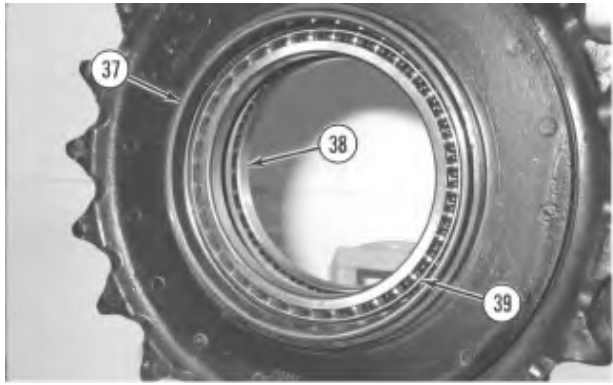

Illustration 1

g00511934

3. Apply Tooling (F) to the surfaces inside the main housing that contact bearings (38) and (39). Install bearings (38) and (39) in the original locations in the main housing with a press. Install bearings (38) and (39) until the bearings contact the counterbore in the main housing.



Illustration 2

g00511872

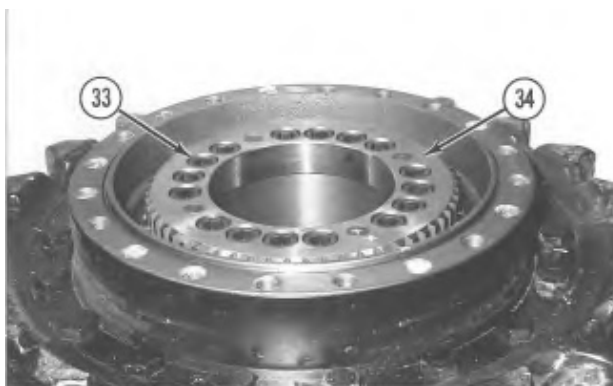

Illustration 3

g00511857

4. Use the following procedure to determine the correct bearing preload and the correct thickness of shims (35) that are used under gear (34).

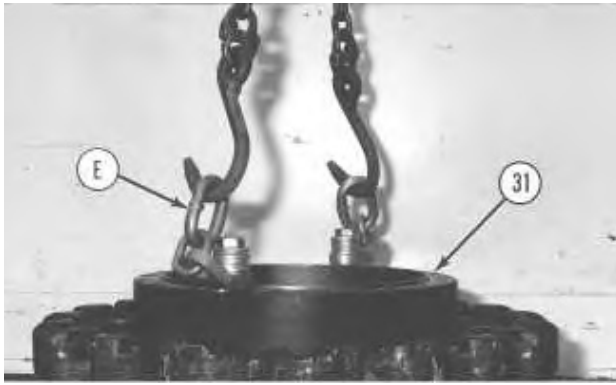

Illustration 4

g00511882

- a. Fasten Tooling (E) and a suitable lifting device to main housing (31), as shown. Install main housing (31) on the motor housing.
- b. Use a suitable press and a spacer to apply a load of 4000 kg (8820 lb) on bearing (38).
- c. Rotate the main housing in order to seat the bearings.
- d. Reduce the load on bearing (38) to 1000 ± 100 kg (2200 ± 220 lb).



Illustration 5

g00513387

- e. Maintain the load on bearing (38). Measure the distance between the top face of the motor housing and the bearing inner race. Use a depth micrometer to take this measurement in several locations around the bearing. Compute the average of the measured dimensions and record the number. Call this dimension (Y).

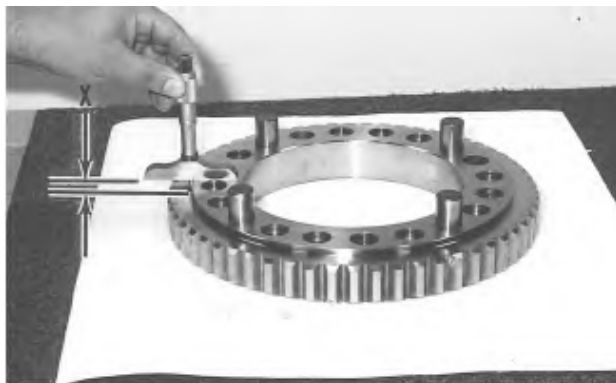

- f. Use a depth micrometer and measure the distance between the hub face and the gear face of gear (34). Take measurements at several locations around the gear. Compute the average of the measured dimensions and record the number. Call this dimension (X).
- g. Determine the correct thickness of the shim pack which is made up of shims (35). The shim pack is used between the motor housing and gear (34). Use the following equation to determine the shim pack thickness.

Shim pack thickness ... $(X) - (Y) \pm 0.05 \text{ mm (0.002 inch)}$

Note: If two shims are required, install the thinner shim next to gear (34) when the gear is installed.

5. Remove the main housing from the motor housing.

Note: The rubber seals and all surfaces that contact the seals must be clean and dry. After installation of the seals, apply clean SAE 30 oil on the contact surfaces of the metal seals. For more information concerning the assembly and installation of Conventional Duo-Cone Seals, refer to Disassembly and Assembly, "Duo-Cone Conventional Seals - Install" in this manual.



Illustration 7

g00513401

6. Install Duo-Cone seal (37) in the main housing with Tooling (D).

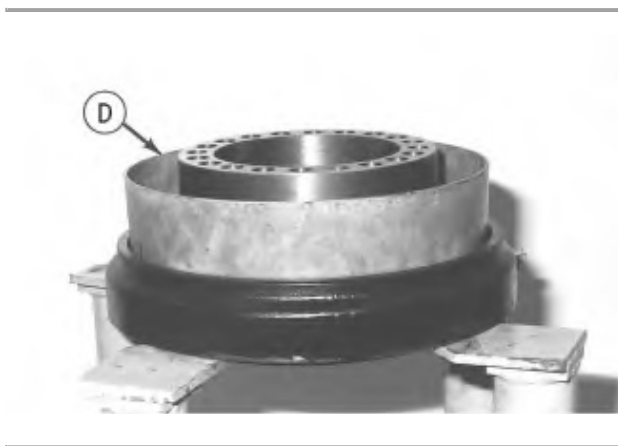

Illustration 8

g00513424

7. Use Tooling (D) in order to install Duo-Cone seal (36) in the motor.

Note: Be sure that the Duo-Cone seals are not scratched or damaged during the assembly of the main housing or during the assembly of the motor housing. After installation of the main housing on the motor housing, there will be a small gap between the components. The gap is caused by the Duo-Cone seals. The gap will be eliminated during installation of gear (34).

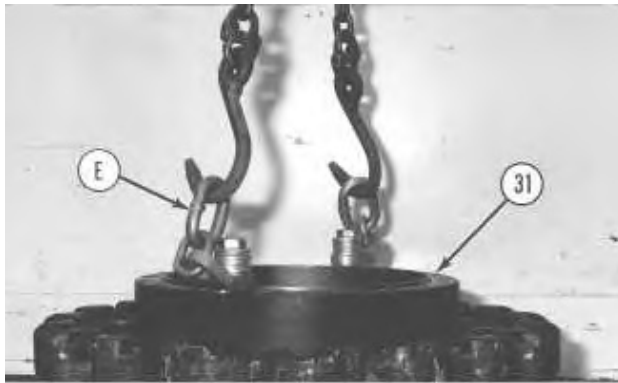

Illustration 9

g00511882

8. Fasten Tooling (E) and a suitable lifting device to main housing (31). Position the main housing and the final drive sprocket on the motor housing. Make sure that the Duo-Cone seals are not scratched or damaged during installation.



Illustration 10

g00511872



Illustration 11

g00511857

9. Apply Tooling (F) on the four pins in gear (34).

10. Place shim pack (35), which was determined in Step 4.a through 4.g, and gear (34) in the correct position on the motor housing. If two shims were required, put the thinner shim in contact with gear (34). Make sure that all of the holes in the components are in alignment with each other.
11. Apply Tooling (G) on the threads of socket head bolts (33). Install the socket head bolts (33) in order to hold gear (34) in place. Tighten bolts (33) evenly and tighten the bolts in diagonally opposite pairs.

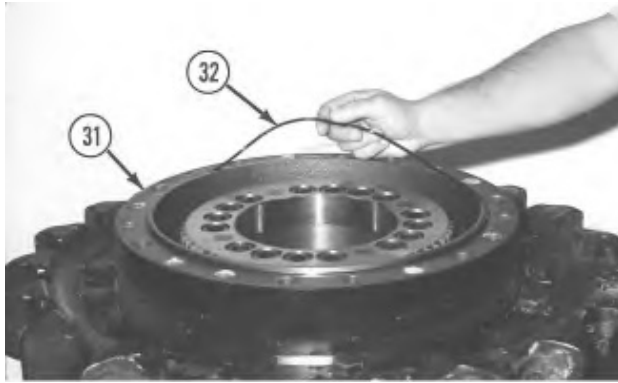

Illustration 12

g00511825

12. Install O-ring seal (32) in main housing (31).

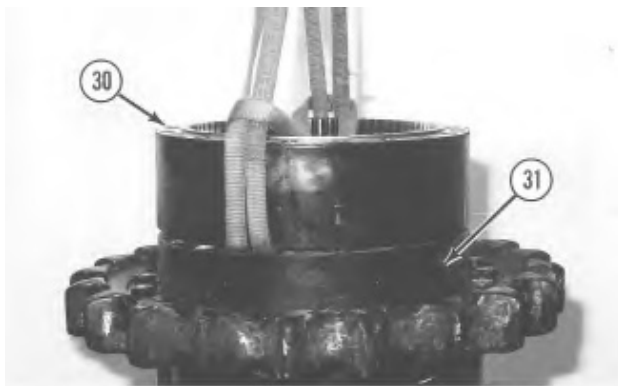

Illustration 13

g00511809

13. Thoroughly clean the mating surface of main housing (31) that contacts ring gear (30). Apply a bead of Tooling (H) on the mating surface of ring gear (30). Fasten a suitable lifting device to ring gear (30). Place ring gear (30) in position on the main housing. Make sure that the alignment mark on the main housing and the alignment mark on the ring gear line up with each other. It may be necessary to use a soft faced hammer to seat the ring gear on the main housing.
-

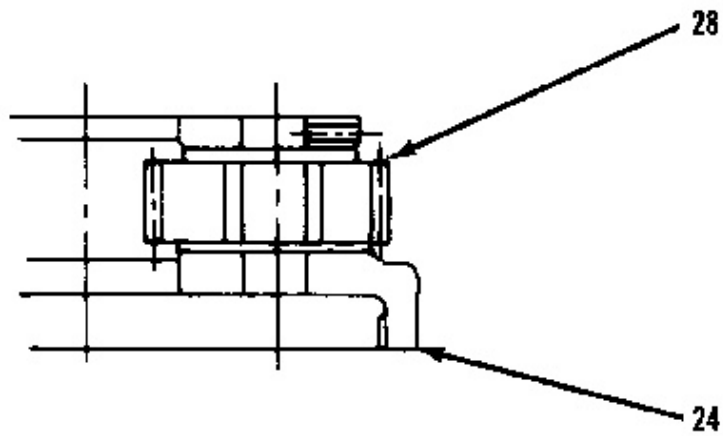

Illustration 14

g00513561

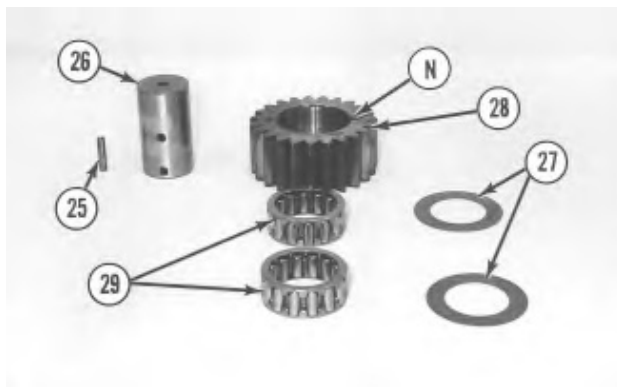

Illustration 15

g00572382

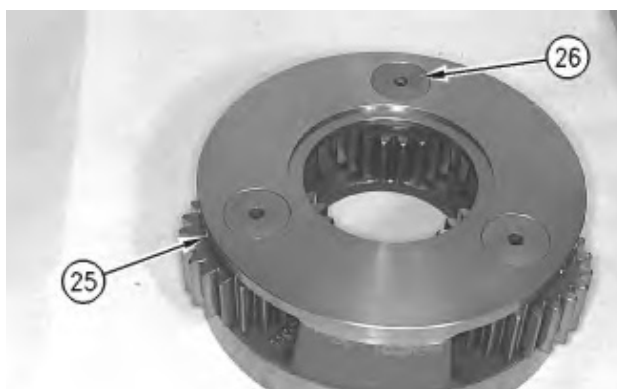

Illustration 16

g00511799

14. Use the following procedure to assemble carrier assembly (24).
 - a. Apply clean SAE 30 oil on bearings (29). Install bearings (29) in planetary gear (28).
 - b. Install thrust washer (27) on each side of planetary gear (28).

- c. Install planetary gear (28) and thrust washers (27) in carrier (24).

Note: If planetary gear (28) has oil grooves "N", make sure that the planetary gear's oil grooves are facing in the correct direction, which was noted during the disassembly of carrier assembly (24).

- d. Install planetary shaft (26) in carrier (24) and through planetary gear (28). Make sure that the spring pin hole in the planetary shaft is in alignment with the spring pin hole in the carrier.

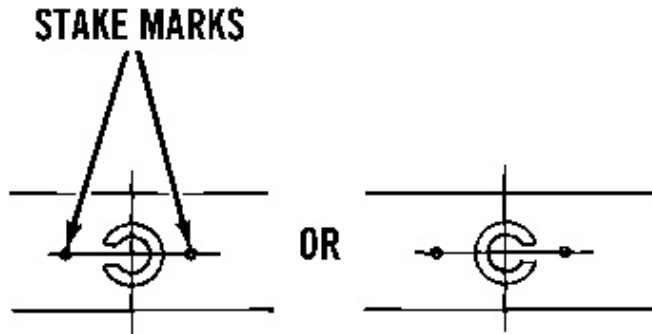

Illustration 17

g00513451

15. Install spring pin (25) in the carrier and into the planetary shaft. Install the spring pin until the spring pin is even with the outside surface of the carrier. Orient the split in the spring pin horizontally to the carrier. Align the split in the spring pin so that the split faces either side of the carrier, as shown.
16. Make a stake mark on each side of the spring pin hole in the carrier. This will prevent the spring pin from falling out of the spring pin hole. Each stake mark should be approximately 1.5 mm (0.06 inch) from the outside diameter of the spring pin hole.
17. Repeat Steps 14 through 16 in order to install the remaining planetary gears in carrier (24).



Illustration 18

g00511795

18. Install carrier assembly (24) in ring gear (30). Slide a piece of steel bar stock between the planetary gears in carrier assembly (24), as shown. Make sure that the bar stock is centered in the carrier assembly. Fasten a suitable lifting device to the steel bar stock, as shown. Position carrier assembly (24) in ring gear (30). It may be necessary to move carrier assembly (24) back and forth during installation in order to ensure that all gears align and all gears mesh properly. Make sure that the carrier assembly is seated properly.
19. Install spacer (16) in carrier assembly (24), as shown.

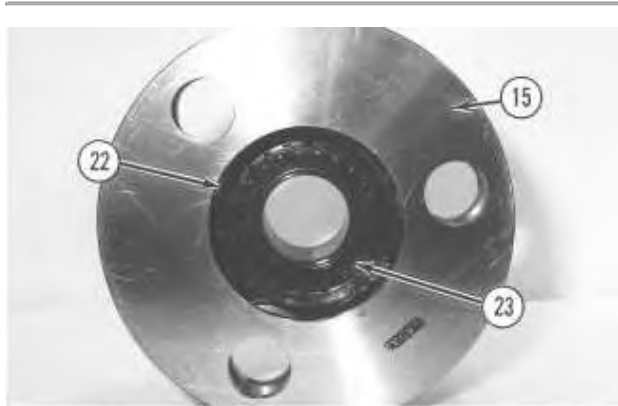

Illustration 19

g00511788

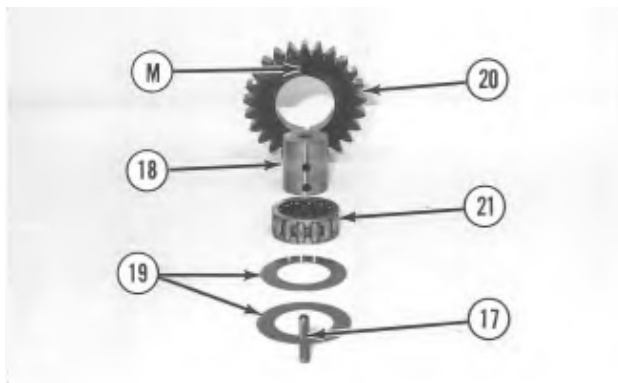

Illustration 20

g00572352

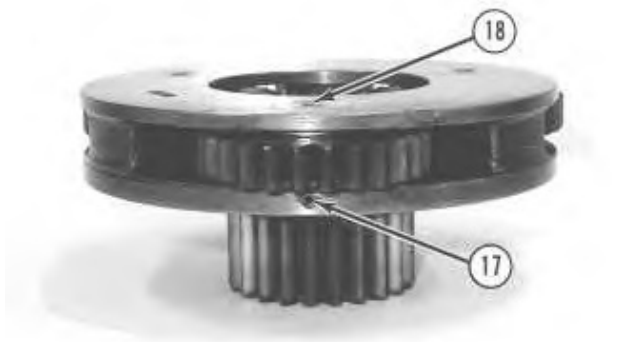

Illustration 21

g00511735

20. Use the following procedure to assemble carrier assembly (15).

- a. Install sun gear (23) in carrier (15).
- b. Use a screwdriver in order to install retaining ring (22) which secures sun gear (23) in the carrier.
- c. Apply clean SAE 30 oil on bearing (21). Install bearing (21) in planetary gear (20).
- d. Install thrust washer (19) on each side of planetary gear (20).
- e. Install planetary gear (20) and thrust washers (19) in carrier (15).

Note: If planetary gear (20) has oil grooves "M", make sure that the planetary gear's oil grooves are facing in the correct direction, which was noted during the disassembly of carrier assembly (15).

- f. Install planetary shaft (18) in carrier (15) and through planetary gear (20). Make sure that the spring pin hole in the carrier is in alignment with the spring pin hole in the planetary shaft.

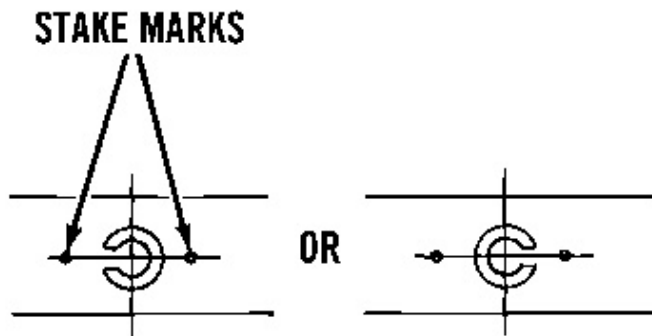

Illustration 22

g00513451

21. Install spring pin (17) in the carrier and into the planetary shaft. Install the spring pin until the spring pin is even with the outside surface of the carrier. Orient the split in the spring pin horizontally to the carrier. Align the split in the spring pin so that the split faces either side of the carrier, as shown.
22. Make a stake mark on each side of the spring pin hole in the carrier. This will prevent the spring pin from falling out of the spring pin hole. Each stake mark should be approximately 1.5 mm (0.06 inch) from the outside diameter of the spring pin hole.
23. Repeat Steps 20 through 22 in order to install the remaining planetary gears in carrier (15).
24. Install carrier assembly (15) in carrier assembly (24). Move the carrier back and forth during the installation in order to ensure that all gears engage properly. Make sure that the carrier assembly is seated properly.
25. Install spacer (8) in the top side of carrier assembly (15).

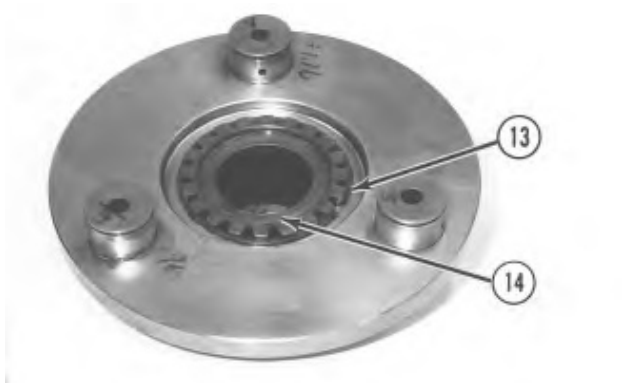

Illustration 23

g00511653

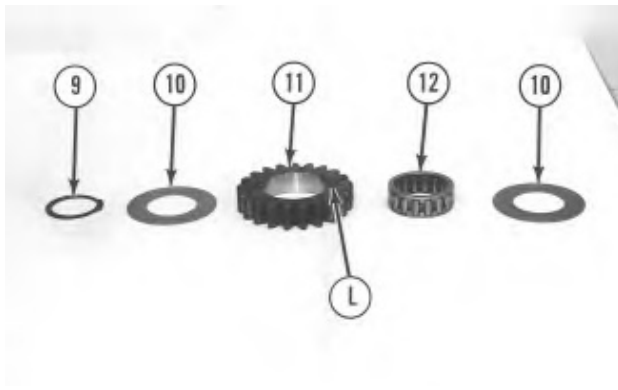

Illustration 24

g00572334

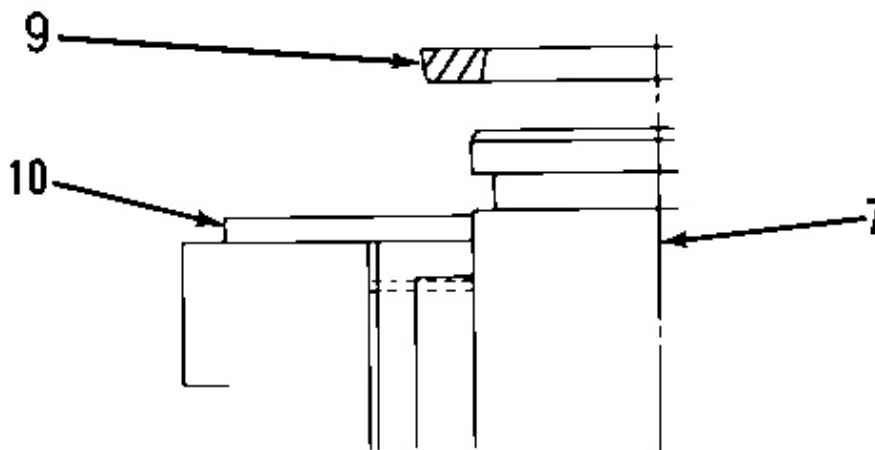

Illustration 25

g00513639

Note: Make sure that retaining ring (9) is installed with the cross section of the ring in the position that is shown. Refer to Illustration 25.

26. Use the following procedure to assemble carrier assembly (7).
 - a. Install sun gear (14) in carrier (7), as shown. Refer to Illustration 23.

- b. Use a screwdriver in order to install retaining ring (13) which secures sun gear (14) in the carrier.
- c. Apply clean SAE 30 oil on bearing (12). Install bearing (12) in planetary gear (11).
- d. Install thrust washer (10) on each side of planetary gear (11).
- e. Install planetary gear (11) and thrust washers (10) on the shaft of carrier (7).

Note: If planetary gear (11) has oil grooves "L", make sure that the planetary gear's oil grooves are facing in the same direction, which was noted during the disassembly of carrier assembly (7).

- f. Use Tooling (C) in order to install retaining ring (9) that secures the planetary gear in position. Make sure that retaining ring (9) is installed correctly. Refer to Illustration 25.

27. Repeat Step 26 in order to install the remaining planetary gears on carrier assembly (7).

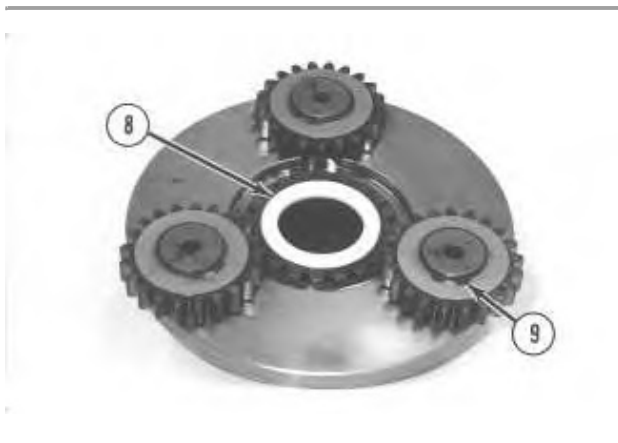

Illustration 26

g00511640

28. Install spacer (8) in carrier assembly (7).

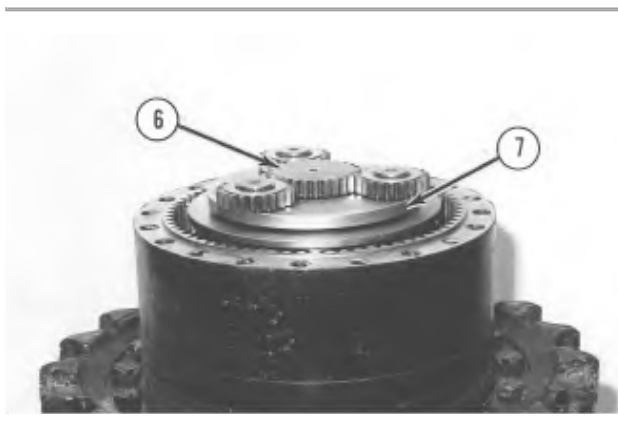

Illustration 27

g00511636

29. Install carrier assembly (7) in carrier assembly (15). Make sure that the carrier assembly is seated properly. Install sun gear (6) in carrier assembly (7).



Illustration 28

g00513653

30. Use a 25.4 mm (1.00 inch) thick straight edge and a depth micrometer in order to measure dimension (P). Dimension (P) is between the upper surface of sun gear (6) and the machined surface of ring gear (30). Record dimension (P).



Illustration 29

g00513657

31. Use a 25.4 mm (1.00 inch) thick straight edge and a depth micrometer in order to measure dimension (Q). Dimension (Q) is from the machined surface of cover (2) to the bottom of the insertion hole of thrust plate (5). Record dimension (Q).

Note: Thrust plate (5) is available in several thicknesses.

32. Determine the correct thickness of thrust plate (5). Use the following equation to determine the thrust plate thickness.

Thrust plate thickness ... $(Q) - (P) - 1.0 \text{ mm (0.04 inch) to } 2.0 \text{ mm (0.08 inch)}$

33. Use a plastic hammer in order to install the correct thickness of thrust plate (5) in cover (2).



Suggest:

If the above button click is invalid.

Please download this document

first, and then click the above link

to download the complete manual.

Thank you so much for reading



Illustration 30

g00511631

34. Put ring gear (4) in position in cover (2). Make sure that all of the mounting bolt holes in both components are in alignment with each other. Apply Tooling (G) on the threads of socket head bolts (3) that hold ring gear (4) in place. Install socket head bolts (3) and tighten socket head bolts (3) evenly.



Illustration 31

g00511600

35. Make sure that the machined surface of ring gear (30) is thoroughly clean and dry and that the machined surface is free of dirt and debris. Apply a bead of Tooling (H) around the machined surface of the ring gear. Fasten Tooling (B) and a suitable lifting device to cover (2). Place the cover in the original position on the ring gear. It will be necessary to rotate the cover back and forth in order to engage the planetary gears of carrier assembly (7) with the ring gear in cover (2).
36. Apply Tooling (G) on the threads of bolts (1) that hold cover (2) in position. Install the washers and bolts (1). Tighten bolts (1) evenly to a torque of $530 \pm 70 \text{ N}\cdot\text{m}$ ($390 \pm 50 \text{ lb ft}$).

End By:

- a. Install the final drive. Refer to Disassembly and Assembly, "Final Drive - Install".

<https://www.ebooklibonline.com>

Hello dear friend!

Thank you very much for reading.

Enter the link into your browser.

The full manual is available for immediate download.

<https://www.ebooklibonline.com>