



Service Repair Manual

Models

325B EXCAVATOR

[Previous Screen](#)

Product: EXCAVATOR
Model: 325B EXCAVATOR 8GM
Configuration: ISJ HEX COMMONALITY CHART 8GM00001-UP (MACHINE)

Disassembly and Assembly Flexxaire Fan

Media Number -REN3699-07

Publication Date -01/02/2012

Date Updated -21/06/2016

i01742852

Mechanical Actuated Fan - Disassemble

SMCS - 1356-015

Preliminary Disassembly Procedure

The following procedures will aid you in failure analysis.

Note: Removal of the fan is not always necessary in order to remove the bellcrank and the control shaft assembly.

Note: If removal of the fan is required, refer to Disassembly and Assembly, "Fan - Remove and Install" for your machine for the procedure to remove the fan.

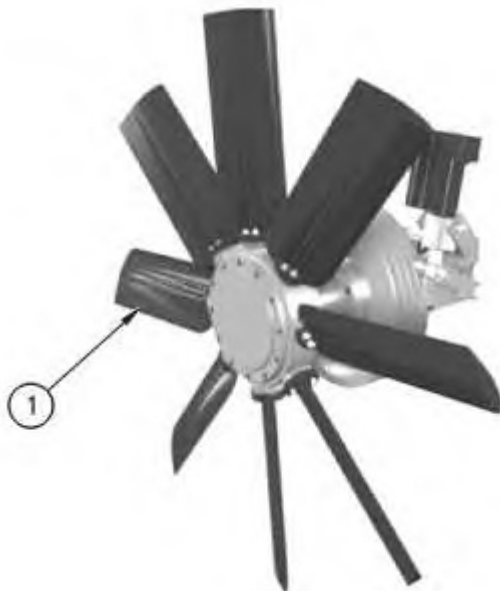

Illustration 1

g00592772

1. Remove blades (1) from the fan assembly.

2. Mount the fan assembly to a stand, if a stand is available.

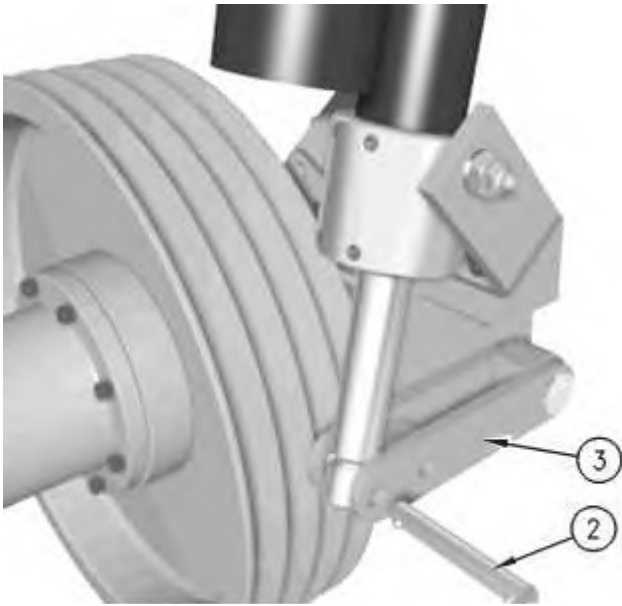

Illustration 2

g00592773

3. Remove hitch pin (2) from operator fork (3).

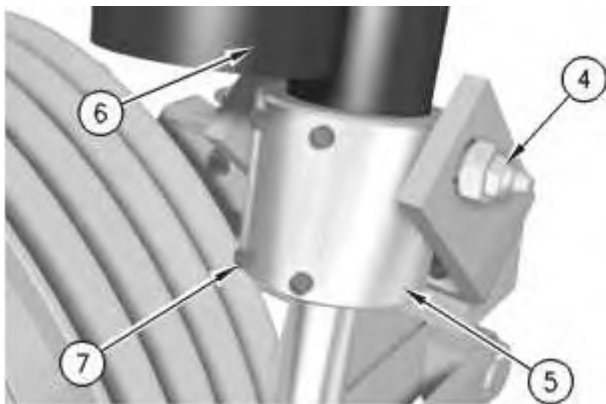

Illustration 3

g00592774

4. Loosen four setscrews (7) and remove actuator (6) from actuator collar (5). If you are unable to loosen setscrews (7), remove shoulder bolts (4) from actuator collar (5).
-

<https://www.ebooklibonline.com>

Hello dear friend!

Thank you very much for reading.

Enter the link into your browser.

The full manual is available for immediate download.

<https://www.ebooklibonline.com>

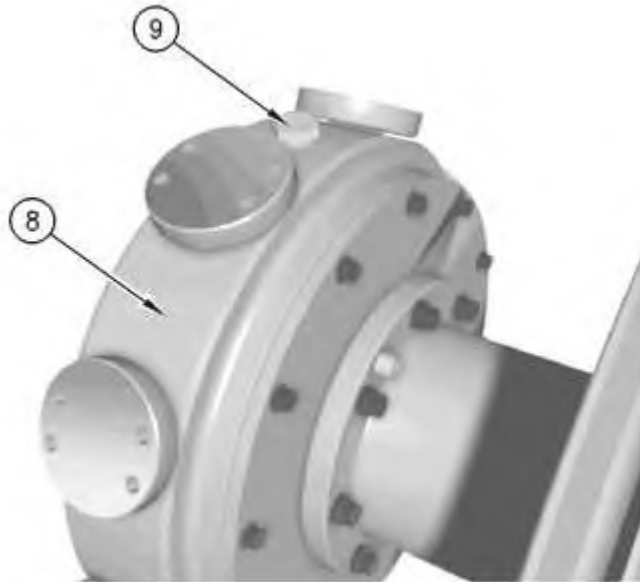

Illustration 4

g00592791

5. Rotate hub (8) until oil filler plug (9) is facing upward.
6. Remove oil filler plug (9).

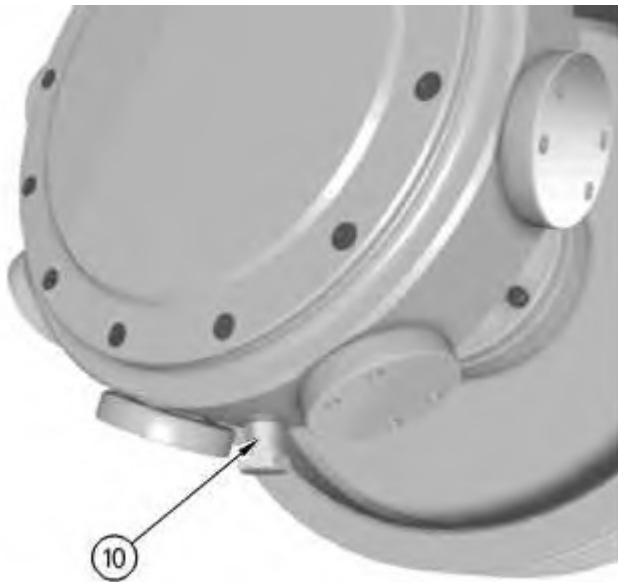

Illustration 5

g00592792

7. Remove oil drain plug (10) and drain the oil into a suitable container. Record the amount of oil that is contained.
8. Install two bolts into one of the blade mounting shafts. Use the bolts in order to rotate the blade mounting shaft through the full range of motion. The operator fork should contact both of the mechanical stops that are located on the alignment plate.

Pressure Test

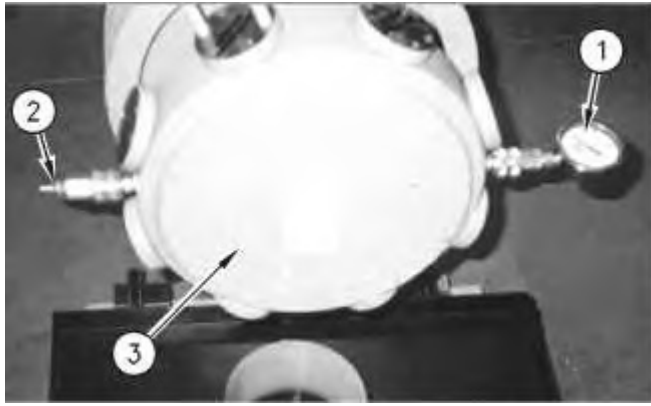

Illustration 6

g00592801

1. Attach air pressure gauge (1) and air chuck (2) into the ports that contained the oil plugs.
2. Pressurize hub (3) with 103.0 kPa (15.0 psi) to 138.0 kPa (20.0 psi) of air.

Note: A 6.9 kPa (1.0 psi) to 20.7 kPa (3.0 psi) pressure drop is immediately evident.

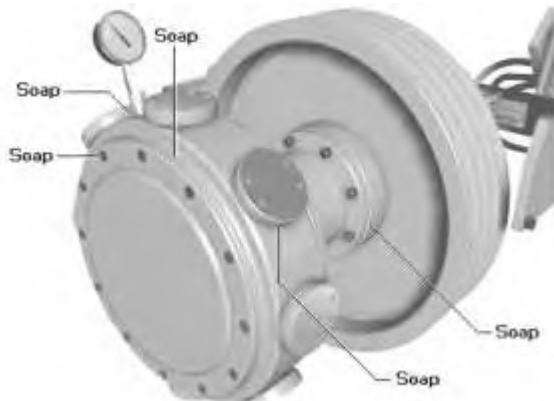

Illustration 7

g00592775

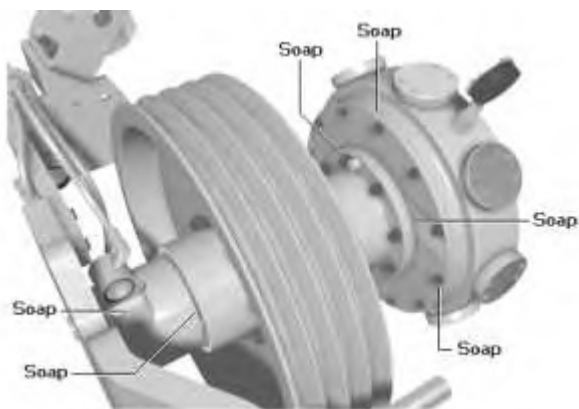

Illustration 8

g00592776

3. Wait for approximately ten minutes. Test all of the sealing surfaces with soap.
4. The area around the bellcrank must also be tested. Removal of the bellcrank cover is required in order to perform a proper test.
5. Again, use the bolts in order to rotate the blade mounting shaft through the full range of motion. The operator fork should contact both of the mechanical stops that are located on the alignment plate.
6. If there are no leaks, increase the air pressure to 206.8 kPa (30.0 psi) and 275.8 kPa (40.0 psi). If leaks are present, record the location of the leak.
7. Repeat Steps 3 through 5.

Bellcrank / Control Shaft Assembly – Remove

1. Use an emery cloth in order to remove the paint from the control shaft. This will allow the shaft to pass freely through the bushings and seals.

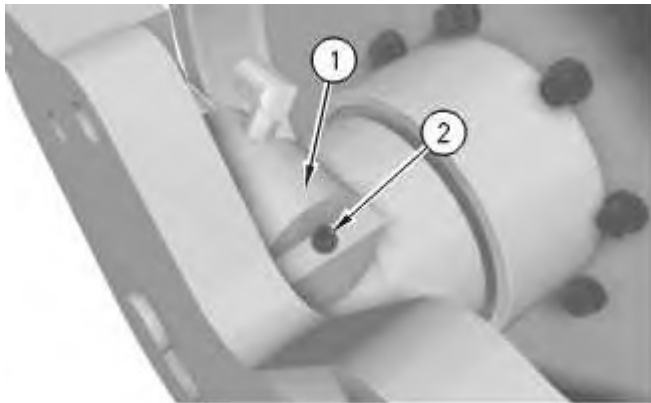

Illustration 9

g00592849

2. Move the operator fork into the NEUTRAL position. Cut the silicone sealant that is around bellcrank cover (1).
3. Remove capscrew (2) that holds bellcrank cover (1) in place and remove the cover.

Note: Not all applications will have capscrew (2). If your application does not have capscrew (2), bellcrank cover (1) is held in place by the silicone sealant, only. Remove the sealant. Set bellcrank cover (1) aside to be reinstalled at a later time.

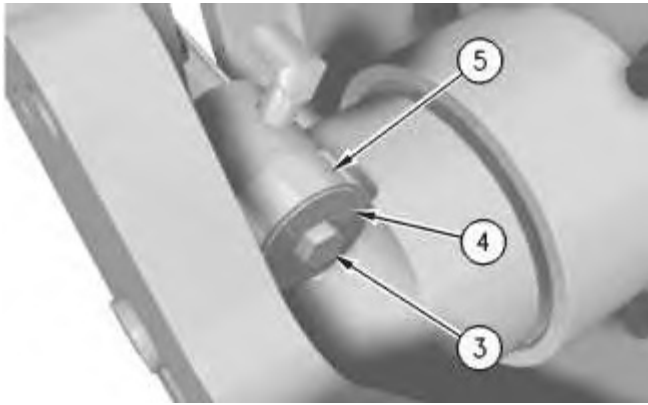

Illustration 10

g00592851

4. Remove bolt (3) and washer (4) that secures bellcrank (5).

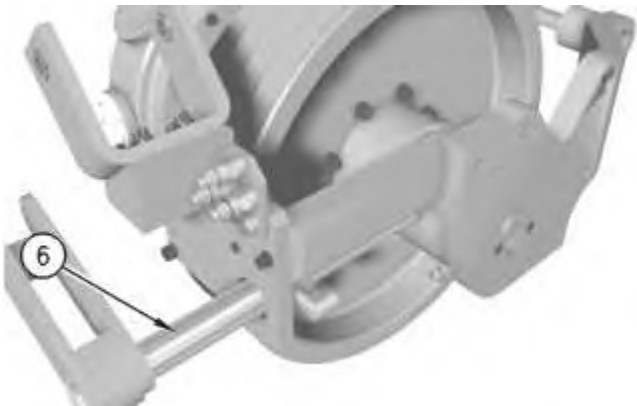

Illustration 11

g00592853

5. Remove control shaft (6).

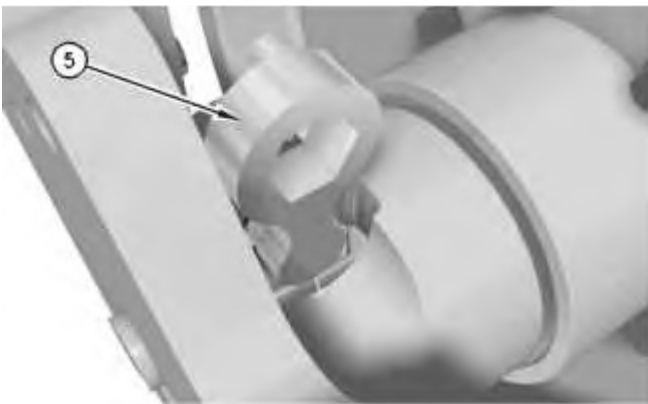

Illustration 12

g00592856

6. Remove bellcrank (5) from the slot. Proceed to "Standard Hub Removal". If you are unable to remove bellcrank (5), the through shaft may have failed. Proceed to "Hub Removal via Front Cover".

Hub Assembly – Remove

Standard Hub Removal

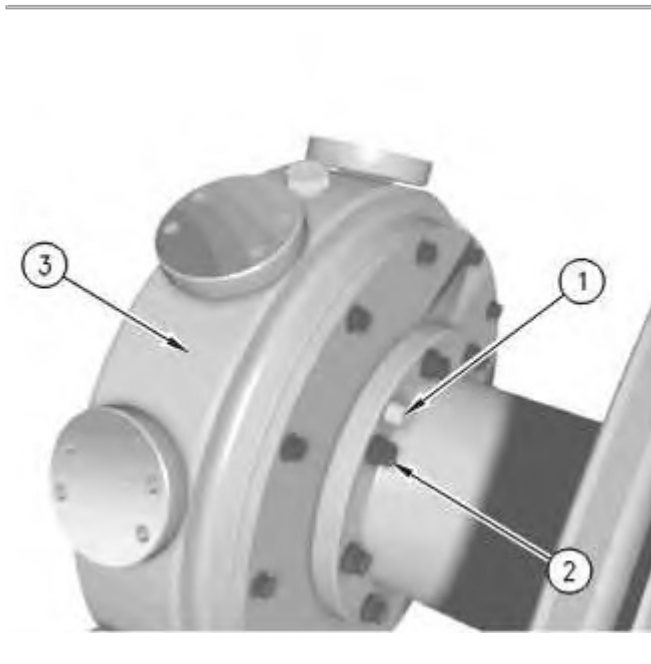

Illustration 13

g00592866

1. Remove oil level plug (1) and capscrews (2) that secure hub assembly (3).

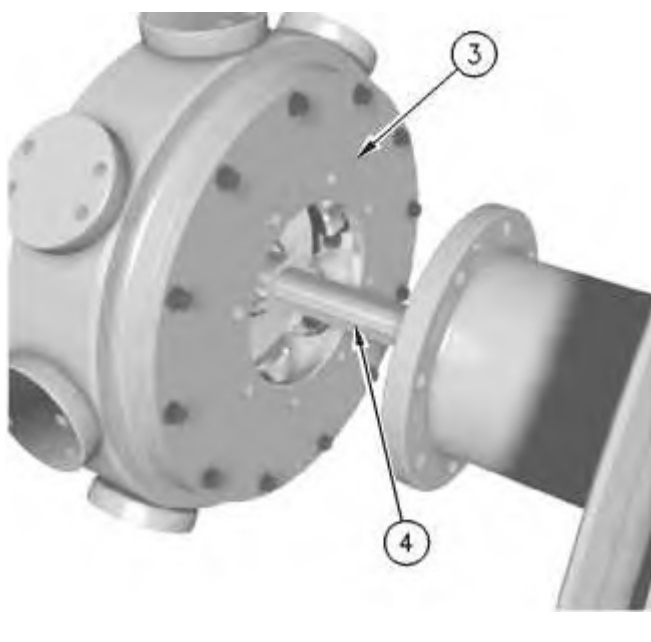

Illustration 14

g00592943

2. Remove hub assembly (3). Through shaft (4) should be removed with hub assembly (3).
-

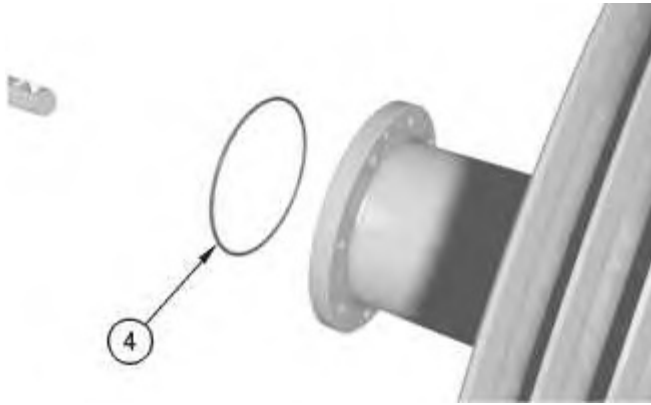

Illustration 15

g00592944

3. Remove O-ring (4).

Hub Removal via Front Cover

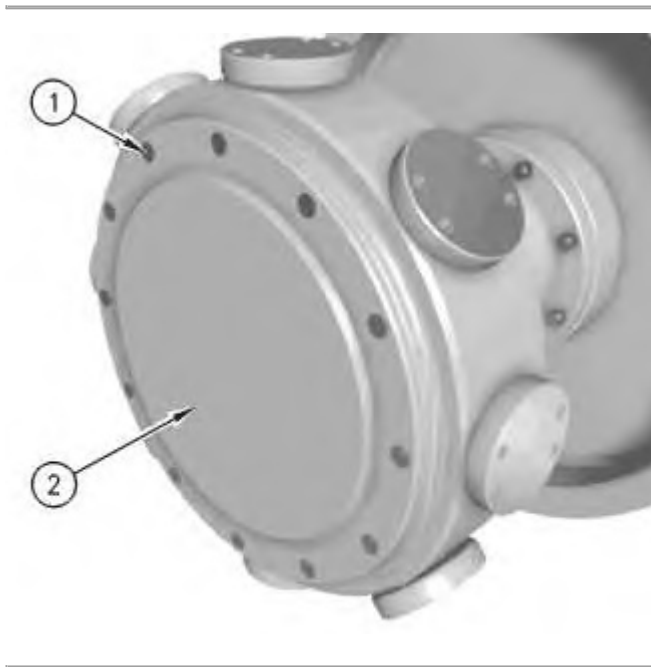

Illustration 16

g00592953

1. Remove capscrews (1) from cover plate (2). Striking the heads of capscrews (1) with a hammer will aid in the removal of the capscrews.



Illustration 17

g00592955

2. Remove cover plate (2) and O-ring (3).



Illustration 18

g00592957

3. Remove six cap screws (4) from front plate (5) of the shifter block assembly.



Illustration 19

g00592966

4. Remove two remaining cap screws (6) and front plate (5).



Illustration 20

g00592971

5. Remove two spacers (7).



Illustration 21

g00592973

6. Rotate blade mounting shafts (8) to the position that is shown. Remove pivot blocks (9) from the collar pins.
7. Rotate blade mounting shafts (8) to the NEUTRAL position.

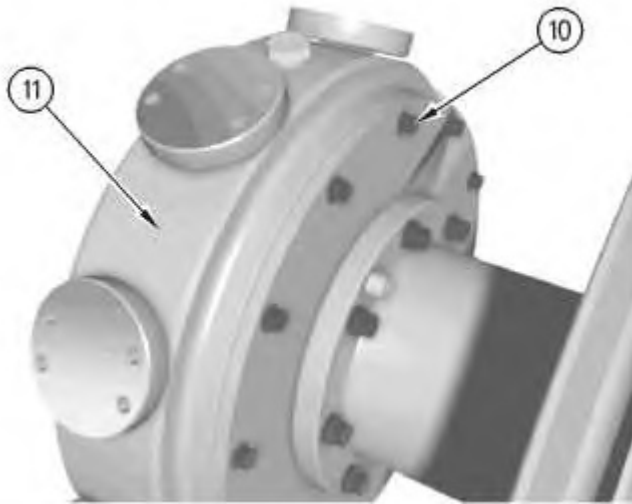

Illustration 22

g00592974

8. Remove capscrews (10) from the hub flange while you support hub assembly (11).

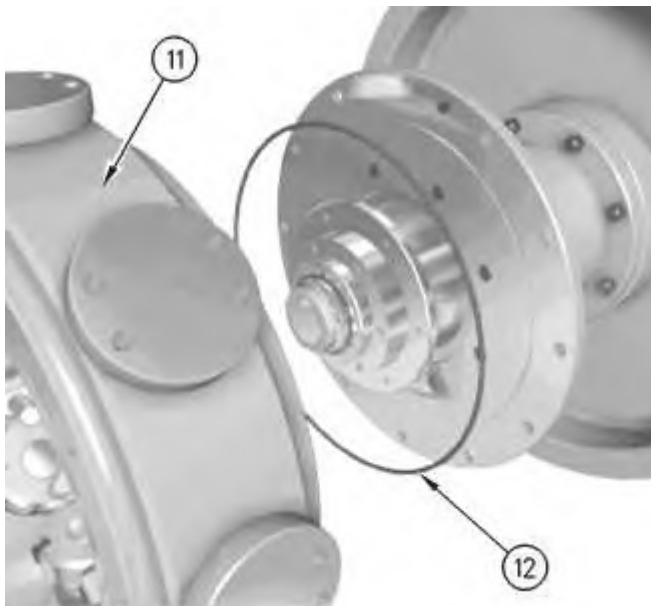

Illustration 23

g00592984

9. Remove hub assembly (11) and O-ring (12).

Through Shaft – Remove

The following procedure is only necessary if you were unable to remove the bellcrank and you must remove the hub via the front cover.



Illustration 24

g00593204

1. Remove bearing locknut (1) and locking washer (2).



Illustration 25

g00593205

2. Use a puller in order to remove the remainder of shifter block assembly (3).

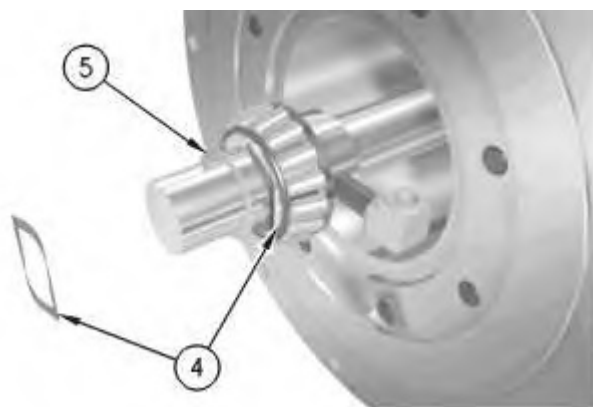

Illustration 26

g00593207

3. Remove two wave washers (4) and flat washer (5). Flat washer (5) is between the wave washers.



Illustration 27

g00593208

4. Remove bearing (6).



Illustration 28

g00593210

5. Remove pickup tube (7).



Illustration 29

g00593274

6. Remove bearing end (8) from through shaft (9).



Illustration 30

g00593311

7. Remove bellcrank (10) from the slot.
8. Remove the through shaft. If the through shaft is damaged, removal through either the front or the rear may be required. This may be difficult if the through shaft has been “mushroomed”.

Carrier/Spool and Main Bearing – Remove

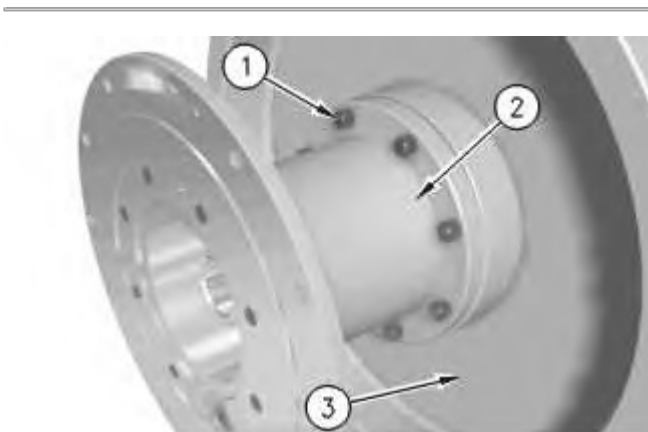

Illustration 31

g00596838

1. Remove capscrews (1) that secure spool (2) to bearing carrier (3).

Note: Some fans do not have a spool. This type of fan only has a combination of a bearing carrier and a spool.

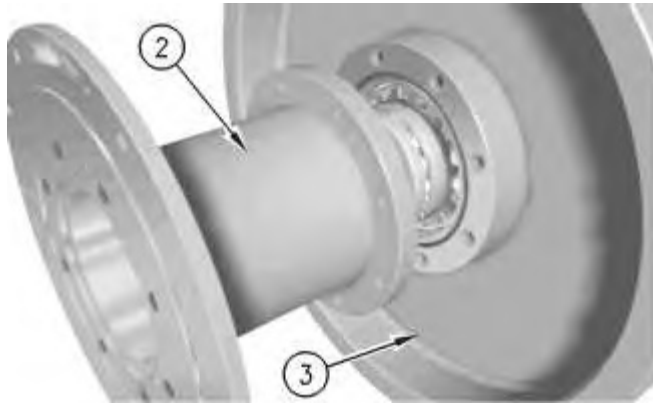

Illustration 32

g00596843

2. Remove spool (2) from bearing carrier (3).

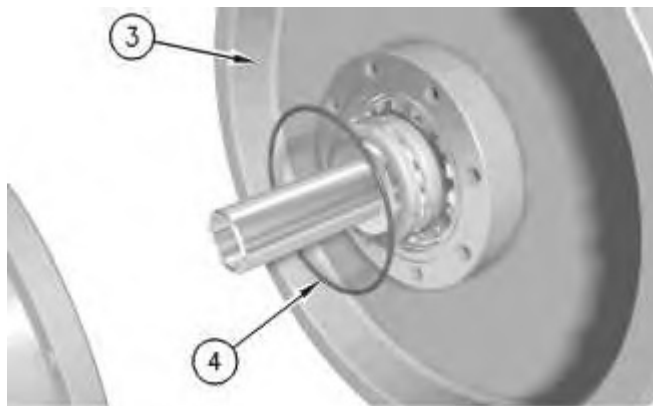

Illustration 33

g00596858

3. Remove O-ring (4).

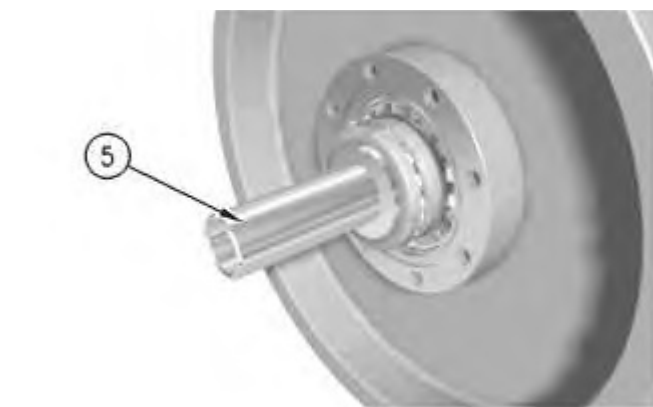

Illustration 34

g00596863

4. Remove main shaft extension (5). Heat may be required in order to remove main shaft extension (5).

Note: Not all fan assemblies have main shaft extension (5).



Illustration 35

g00596859

5. Remove bearing locknut (6) and locking washer (7).

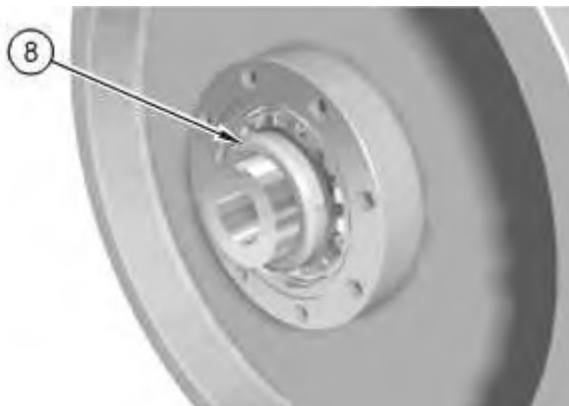

Illustration 36

g00596867

6. Remove bearing locknut (8).

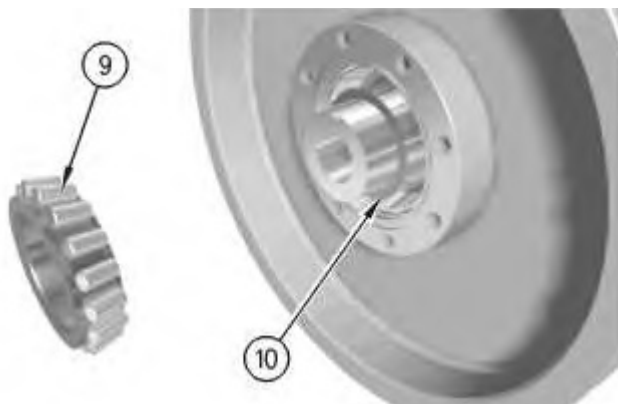

Illustration 37

g00596873

7. Remove bearing (9) and washer (10).
-



Illustration 38

g00596875

8. Remove washer (11) and spacer (12).

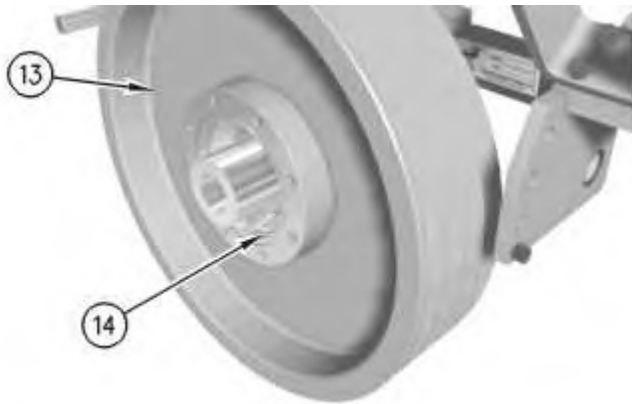

Illustration 39

g00596876

9. Carefully remove pulley (13) and bearing carrier assembly (14).

Note: Do not damage the threads on the main shaft.



Illustration 40

g00596893

10. Remove fillet spacer (15).

Note: Not all fan assemblies have fillet spacer (15).

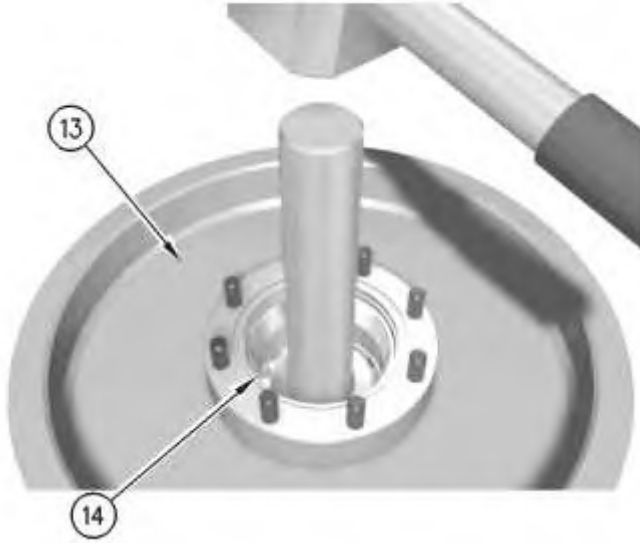

Illustration 41

g00596895

11. Place pulley (13) and bearing carrier assembly (14) downward.
-

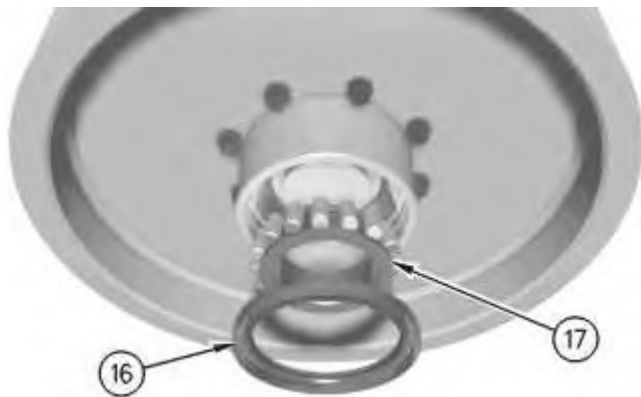

Illustration 42

g00596937

12. Remove rear seal (16) and bearing cone (17) through the bearing carrier bore.
-

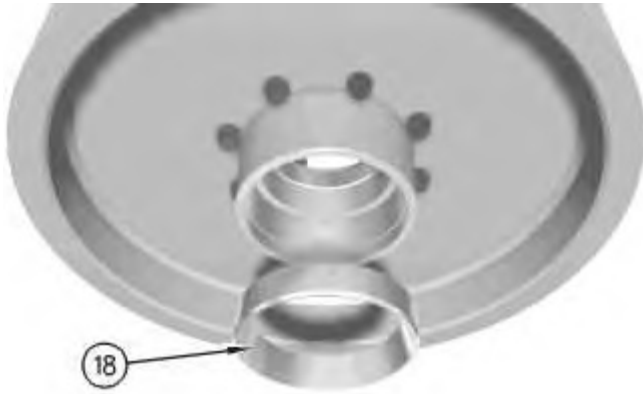

Illustration 43

g00596939

13. Remove bearing cups (18) from the bearing carrier bore.

Note: Do not damage the bearing bores when you remove bearing cups (18).

Frost Plug and Main Shaft O-Ring – Remove



Illustration 44

g00597026

1. Remove internal O-Ring (1). This can be done from either side of the main shaft. O-Ring (1) is seated inside the main shaft.



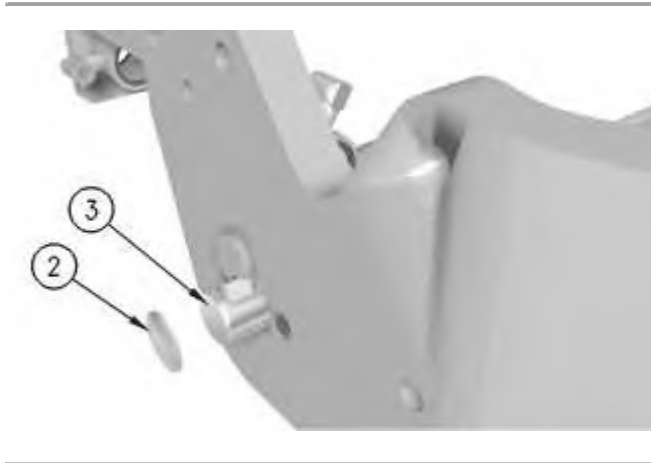

Illustration 46

2. Drive out frost plug (2). Remove bushing (3), if necessary.

Note: Unless the main shaft has been damaged, it is not necessary to remove the main shaft.

3. If there is scoring on the inside of the bushing or if there is excessive play between the through shaft and the bushing, remove the rear bushing from the main shaft.

Note: Some fans do not have main shaft extensions. Rather, the fans have a second bushing in the front of the main shaft.

Note: Removal and installation of the bushings can cause damage to the main shaft bushing bores.

Note: Replacement bushings for the rear side of the main shaft will not have a slot. The slot must be cut out after installing the new bushing.

4. Remove the bushing from the main shaft extension, if necessary.

Hub – Disassemble

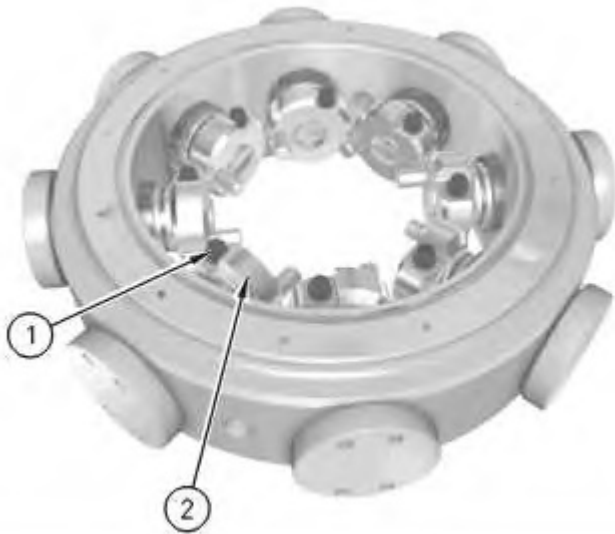

Illustration 47

g00597034

1. Remove capscrews (1) from collars (2).



Illustration 48

g00597036



Illustration 49

g00597047



Suggest:

If the above button click is invalid.

Please download this document

first, and then click the above link

to download the complete manual.

Thank you so much for reading

2. Remove blade mounting shafts (3) and nylon washers (4). Hold the collar and the bearing when you remove the shafts and washers.



Illustration 50

g00597037

3. Remove collars (2) and bearings (5).

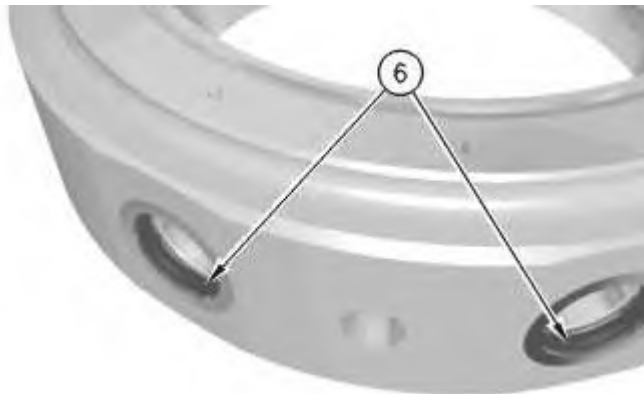

Illustration 51

g00597038

4. Remove O-Rings (6) from the hub inserts.

Note: Carefully remove O-Rings (6) so that damage to the O-Ring grooves does not occur.

5. Inspect the O-Ring grooves for pitting, rust or other surface defects that may cause leakage.

Actuator Spherical Bearings and Control Shaft Bushings – Remove

<https://www.ebooklibonline.com>

Hello dear friend!

Thank you very much for reading.

Enter the link into your browser.

The full manual is available for immediate download.

<https://www.ebooklibonline.com>