

# CRAWLER EXCAVATOR CX160B-CX180B SERVICE MANUAL

## TABLE OF CONTENTS

DIVISION/SECTION	SECTION N°	REFERENCE N°
<b>1 GENERAL INFORMATION</b>		
Safety, general information and standard torque data .....	1001	7-27691EN
General specifications and special torque setting.....	1002	SC160B1002-0EN
<b>2 ENGINE</b>		
Engine specifications .....	*	
Disassembly and assembly of the engine .....	*	
<b>3 FUEL SYSTEM</b>		
Fuel tank .....	3001	SM160B3001-0EN
Fuel engine system.....	*	
<b>4 ELECTRICAL SYSTEM</b>		
Electrical system, electrical and electronic troubleshooting.....	4001	SC210B4001-1EN
Electrical equipment and electrical circuit diagrams .....	4020	SC210B4020-0EN
<b>5 UNDERCARRIAGE</b>		
Removal and installation of tracks .....	5001	SM160B5001-0EN
Rollers .....	5003	SM160B5003-0EN
Sprocket.....	5004	SM160B5004-0EN
Idler wheel and tension shock absorber .....	5005	SM160B5005-0EN
<b>6 DRIVE TRAIN</b>		
Drive motor and final drive transmission removal and installation .....	6001	SM160B6001-0EN
Drive motor and final drive transmission disassembly and assembly .....	6002	SM160B6002-0EN
Swing reduction gear, removal and installation.....	6003	SM160B6003-0EN
Swing reduction gear, disassembly and assembly.....	6004	SM210B6004-0EN
<b>7 UNDERCARRIAGE HYDRAULICS</b>		
<b>8 UPPERSTRUCTURE HYDRAULICS</b>		
Depressurising and decontaminating the hydraulic system, use of the vacuum pump and bleeding the components .....	8000	SM160B8000-0EN
Specifications, troubleshooting, checks and hydraulic pressure settings.....	8001	SC160B8001-0EN
Hydraulic reservoir removal and installation .....	8002	SM160B8002-0EN
Attachment cylinders, removal and installation .....	8005	SM160B8005-0EN
Hydraulic swivel, removal and installation .....	8006	SM160B8006-0EN
Pilot blocs, removal and installation .....	8007	SM160B8007-0EN
Swing motor, removal and installation.....	8008	SM160B8008-0EN
Main hydraulic pump, disassembly and assembly .....	8010	SM160B8010-0EN
Main hydraulic control valve, disassembly and assembly .....	8011	SM160B8011-0EN
Hand control levers, disassembly and assembly .....	8013	SM160B8013-0EN
Foot control levers, disassembly and assembly.....	8014	SM160B8014-0EN
Caution valve, disassembly and assembly.....	8016	SM160B8016-0EN
Swing motor, disassembly and assembly .....	8019	SM160B8019-0EN
Hydraulic functions.....	8020	SC160B8020-1EN
Hydraulic component functions.....	8030	SC160B8030-0EN

DIVISION/SECTION	SECTION N°	REFERENCE N°
<b>9 UPPERSTRUCTURE</b>		
Quick coupler.....	9000	SM160B9000-0EN
Upperstructure, turntable and counterweight.....	9002	SM160B9002-0EN
Boom, dipper and bucket.....	9003	SM160B9003-0EN
Seat, removal and installation.....	9004	SM160B9004-0EN
Cab and cab equipment.....	9005	SM160B9005-0EN
Air conditioner functions and troubleshooting.....	9006	SC210B9006-0EN
Large size hydraulic schematics.....	Pocket	87593994B
Large size electrical schematics.....	Pocket	87594000A

\* *Consult the Engine Service Manual*

NOTE: CNH Company reserves the right to make changes in the specification and design of the machine without prior notice and without incurring any obligation to modify units previously sold.

The description of the models shown in this manual has been made in accordance with the technical specifications known as of the date of design of this document.

# Section

# 1001

**SAFETY, GENERAL INFORMATION  
AND TORQUE SPECIFICATIONS**

**<https://www.ebooklibonline.com>**

Hello dear friend!

Thank you very much for reading.

Enter the link into your browser.

The full manual is available for immediate download.

**<https://www.ebooklibonline.com>**

## TABLE OF CONTENTS

GENERAL INFORMATION .....	3
SAFETY.....	4
STANDARD TORQUE DATA FOR CAP SCREWS AND NUTS.....	6



**WARNING :** *This symbol is used in this manual to indicate important safety messages. Whenever you see this symbol, carefully read the message that follows, as there is a risk of serious injury.*

## GENERAL INFORMATION

### Cleaning

Clean all metal parts except bearings, in a suitable cleaning solvent or by steam cleaning. Do not use caustic soda for steam cleaning. After cleaning, dry and put oil on all parts. Clean oil passages with compressed air. Clean bearings in a suitable cleaning solvent, dry the bearings completely and put oil on the bearings.

### Inspection

Check all parts when the parts are disassembled. Replace all parts that have wear or damage. Small scoring or grooves can be removed with a hone or crocus cloth. Complete a visual inspection for indications of wear, pitting and the replacement of parts necessary to prevent early failures.

### Bearings

Check bearings for easy action. If bearings have a loose fit or rough action replace the bearing. Wash bearings with a suitable cleaning solvent and permit to air dry. **DO NOT DRY BEARINGS WITH COMPRESSED AIR.**

### Needle bearings

Before you press needle bearings in a bore always remove any metal protrusions in the bore or edge of the bore. Before you press bearings into position put petroleum jelly on the inside and outside diameter of the bearings.

### Gears

Check all gears for wear and damage. Replace gears that have wear or damage.

### Oil seals, O-rings and gaskets

Always install new oil seals, O-rings and gaskets. Put petroleum jelly on seals and O-rings.

### Shafts

Check all shafts that have wear or damage. Check the bearing and oil seal surfaces of the shafts for damage.

### Service parts

Always install genuine Case service parts. When ordering refer to the Parts Catalog for the correct part number of the genuine Case replacement items. Failures due to the use of other than genuine Case replacement parts are not covered by warranty.

### Lubrication

Only use the oils and lubricants specified in the Operator's or Service Manuals. Failures due to the use of non-specified oils and lubricants are not covered by warranty.

## SAFETY



*This symbol means ATTENTION! BECOME ALERT! YOUR SAFETY IS INVOLVED. The message that follows the symbol contains important information about safety. Carefully read the message. Make sure you fully understand the causes of possible injury or death.*

To prevent injury always follow the Warning, Caution and Danger notes in this section and throughout the manual.

Put the warning tag shown below on the key for the keyswitch when servicing or repairing the machine. One warning tag is supplied with each machine. Additional tags Part Number 331-4614 are available from your service parts supplier.



**WARNING:** Read the operator's manual to familiarize yourself with the correct control functions.



**WARNING:** Operate the machine and equipment controls from the seat position only. Any other method could result in serious injury.



**WARNING:** This is a one man machine, no riders allowed.



**WARNING:** Before starting engine, study Operator's Manual safety messages. Read all safety signs on machine. Clear the area of other persons. Learn and practice safe use of controls before operating.

*It is your responsibility to understand and follow manufacturers instructions on machine operation, service and to observe pertinent laws and regulations. Operator's and Service Manuals may be obtained from your Case dealer.*



**WARNING:** If you wear clothing that is too loose or do not use the correct safety equipment for your job, you can be injured. Always wear clothing that will not catch on objects. Extra safety equipment that can be required includes hard hat, safety shoes, ear protection, eye or face protection, heavy gloves and reflector clothing.



**WARNING:** When working in the area of the fan belt with the engine running, avoid loose clothing if possible, and use extreme caution.



**WARNING:** When doing checks and tests on the equipment hydraulics, follow the procedures as they are written. DO NOT change the procedure.



**WARNING:** When putting the hydraulic cylinders on this machine through the necessary cycles to check operation or to remove air from a circuit, make sure all people are out of the way.



**WARNING:** Use insulated gloves or mittens when working with hot parts.



**WARNING:** Lower all attachments to the ground or use stands to safely support the attachments before you do any maintenance or service.



**WARNING:** Pin sized and smaller streams of hydraulic oil under pressure can penetrate the skin and result in serious infection. If hydraulic oil under pressure does penetrate the skin, seek medical treatment immediately. Maintain all hoses and tubes in good condition. Make sure all connections are tight. Make a replacement of any tube or hose that is damaged or thought to be damaged. DO NOT use your hand to check for leaks, use a piece of cardboard or wood.



**WARNING:** When removing hardened pins such as a pivot pin, or a hardened shaft, use a soft head (brass or bronze) hammer or use a driver made from brass or bronze and a steel head hammer.



**WARNING:** When using a hammer to remove and install pivot pins or separate parts using compressed air or using a grinder, wear eye protection that completely encloses the eyes (approved goggles or other approved eye protectors).



**WARNING:** Use suitable floor (service) jacks or chain hoist to raise wheels or tracks off the floor. Always block machine in place with suitable safety stands.



**WARNING:** When servicing or repairing the machine, keep the shop floor and operator's compartment and steps free of oil, water, grease, tools, etc. Use an oil absorbing material and/or shop cloths as required. Use safe practices at all times.



**WARNING:** Some components of this machine are very heavy. Use suitable lifting equipment or additional help as instructed in this Service Manual.



**WARNING:** Engine exhaust fumes can cause death. If it is necessary to start the engine in a closed place, remove the exhaust fumes from the area with an exhaust pipe extension. Open the doors and get outside air into the area.



**WARNING:** When the battery electrolyte is frozen, the battery can explode if (1), you try to charge the battery, or (2), you try to jump start and run the engine. To prevent the battery electrolyte from freezing, try to keep the battery at full charge. If you do not follow these instructions, you or others in the area can be injured.

## STANDARD TORQUE DATA FOR CAP SCREWS AND NUTS

### Tightening of cap screws, nuts

Tighten alternately so that tightening torque can be applied evenly. The numbers in the figure below indicate the order of tightening.

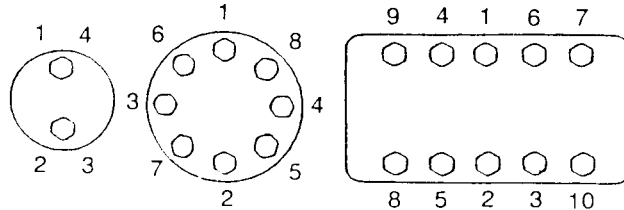

JS00481A

Cap screws which have had Loctite used (white residue remains after removal) should be cleaned with light oil or suitable cleaning solvent and dried. Apply 2-3 drops of Loctite to the thread portion of the cap screw and then tighten.

### Torque table

Tighten cap screws and nuts according to the table below if there are no other special instructions.

Cap Screw Name Size (Size)			M6	M8	M10	M12	M14	M16	M18	M20
Cap Screw	Spanner	[mm]	10	13	17	19	22	24	27	30
		[in.]	0.39	0.51	0.67	0.75	0.87	0.95	1.06	1.18
	Tightening torque	[Nm]	6.9	19.6	39.2	58.8	98.1	156.9	196.1	294.2
		[lb-ft]	5.1	14.5	28.9	43.4	72.3	115.7	144.6	217
Socket Head Cap Screw	Spanner	[mm]	5	6	8	10	12	14	14	17
		[in.]	0.20	0.24	0.32	0.39	0.47	0.55	0.55	0.67
	Tightening torque	[Nm]	8.8	21.6	42.1	78.5	117.7	176.5	245.2	343.2
		[lb-ft]	6.5	15.9	31.1	57.9	86.9	130.2	181	253.2

# **Section 1002**

**1002**

## **SPECIFICATIONS AND SPECIAL TORQUE SETTINGS**

## TABLE OF CONTENTS



**WARNING:** *This symbol is used in this manual to indicate important safety messages. Whenever you see this symbol, carefully read the message which follows. Your safety depends on it.*

TYPE, SERIAL NUMBER AND YEAR OF MANUFACTURE OF THE MACHINE .....	3
Machine .....	3
Engine .....	3
Serial numbers of the components .....	3
FLUIDS AND LUBRICANTS .....	4
Hydraulic fluid .....	4
Transmission component oil .....	4
Grease .....	4
Engine Oil .....	5
Engine fuel, maintenance of fuel filters and fuel storage .....	6
Anti-freeze/Anti-corrosion.....	8
Environment.....	8
Plastic and resin parts.....	8
SPECIFICATIONS .....	9
Main data .....	9
Performance .....	9
Complete machine dimensions .....	9
Main body dimensions .....	10
Engine.....	10
Cooling system .....	10
Capacity of coolant and lubricants .....	11
Hydraulic oil filter.....	11
Fuel filter .....	11
Operating devices .....	11
Hydraulic system.....	12
Swing unit .....	14
Travel lower body.....	14
Work Unit .....	15
Digging force (ISO 6015) .....	17
COMPONENT WEIGHT .....	18
Major component weight.....	18
Other component weight.....	19
SPECIAL TORQUE SETTINGS.....	20
MACHINE OVERALL DIMENSIONS .....	24

# TYPE, SERIAL NUMBER AND YEAR OF MANUFACTURE OF THE MACHINE

For all part orders, request for information or assistance, always specify the type and the serial number of the machine to your Case dealer.

Fill in the following lines with the required information: Type, serial number, year of manufacture of the machine and the serial numbers of the hydraulic and mechanical components.

## Machine

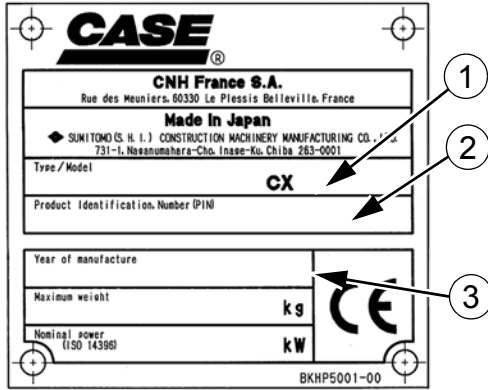

CT04A171A

(1) Type .....

(2) Serial number .....

(3) Year of manufacture.....

## Engine

Make and type.....

Serial number.....

## Serial numbers of the components

Hydraulic pump .....

Swing reduction gear .....

Travel reduction gears.....

Control valve .....

## FLUIDS AND LUBRICANTS

Lubricants must have the correct properties for each application.

 **WARNING:** The conditions of use for individual fluids and lubricants must be respected.

### Hydraulic fluid

CASE/AKCELA hydraulic fluid is specially designed for high pressure applications and for the CASE hydraulic system. The type of fluid to be used depends on the ambient temperature.

**Temperate climates: -20°C to +40°C (-4° to 104° F)**

CASE/AKCELA: HYDRAULIC EXCAVATOR FLUID (MS 1230. ISO VG 46. DIN 51524 PART 2 HV)

**Hot climates: 0°C to +50°C (32° to 122° F)**

CASE/AKCELA: AW HYDRAULIC FLUID 68 HV (MS 1216. ISO VG 68. DIN 51524 PART 3 CATEGORY HVLP)

**Cold climates: -25°C to +20°C (-13° to 68° F)**

CASE/AKCELA: AW HYDRAULIC FLUID 32 (MS 1216. ISO VG 32. DIN 51524 PART 2)

**Biodegradable fluid: -30°C to +40°C (-22° to 104° F)**

This yellow-colored fluid is miscible with standard fluid. If used to change standard fluid, it is advised to drain the circuit completely before refilling with this fluid.

CASE/AKCELA: HYDRAULIC EXCAVATOR FLUID BIO (MS 1230. ISO VG 46. DIN 51524 PART 2 HV)

### Transmission component oil

Extreme pressure oil used for enclosed transmission components.

CASE/AKCELA: GEAR 135H EP (SAE 80W-90. API GL 5. MIL-L-2105 D. MS 1316. ZF TE-ML 05A)

### Grease

CASE/AKCELA: MOLY GREASE 251H EP-M (251H EP-M. NLGI 2)

"Extreme Pressure" multipurpose grease with lithium soap and molybdenum disulphide.

CASE/AKCELA: MULTIPURPOSE GREASE 251H EP (251H EP. NLGI 2)

"Extreme Pressure" multipurpose grease with lithium soap and calcium.

CASE/AKCELA: PREMIUM GREASE EP2 (NLGI 2)

"Extreme Pressure" multipurpose grease with lithium soap.

### Hydraulic breakers

CASE/AKCELA: MULTIPURPOSE GREASE 251H EP (NLGI 2).

# Engine Oil

THE CASE/AKCELA No. 1 engine oil is recommended for your engine. This oil ensures proper lubrication of your engine for all operating conditions.

If the CASE/AKCELA Multigrade "No. 1 ENGINE OIL" cannot be obtained, use the oil corresponding to one of the following categories: ACEA E7. API CI-4.

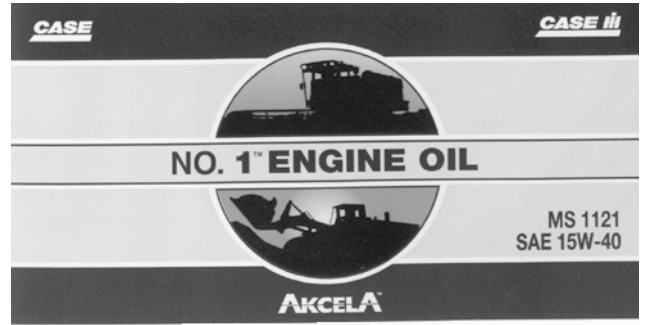

CP02N001

## Oil viscosity / Oil range

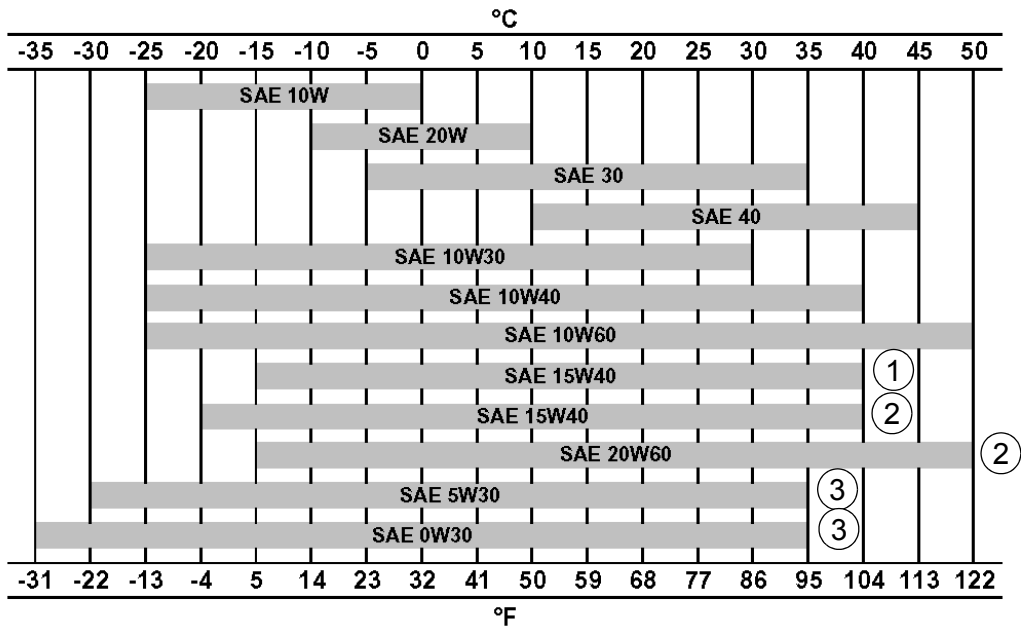

CT02M001

- 1) With mineral base
- 2) With semi-synthetic base
- 3) With synthetic base

## Engine fuel, maintenance of fuel filters and fuel storage

In order to meet the emission control regulation of 3rd-stage, the engine components have been made precisely and they are to be used under high-pressure conditions.

Therefore, the specified fuel must be used for the engine.

As a matter of course, not only the guarantee will not be given for the use of a fuel other than the specified but also it may invite a serious breakdown.

In addition, since suitable specifications for the fuel filter elements have been established for this engine, use of the genuine filter is essential.

The following describes the specifications and the requirements of the fuel to be applied, and maintenance of the fuel and the fuel elements.

### Fuel to be applied

#### Selection of fuel

Following conditions must be met for the diesel engines, that is the one;

- 1 In which no dust even fine one is mixed,
- 2 With proper viscosity,
- 3 With high cetane rating,
- 4 With good flow properties in lower temperature,
- 5 With not much sulfur content, and
- 6 With less content of carbon residue

#### Applicable standards for diesel fuel

Applicable Standard	Recommendation
JIS (Japanese Industrial Standard)	NO.2
DIN (Deutsche Industrie Normen)	DIN 51601
SAE (Society of Automotive Engineers)	
Based on SAE-J-313C	NO. 2-D
BS (British Standard) Based on BS/2869-197	Class A-1
EN590	

If a standard applied to the fuel for the diesel engine is stipulated in your country, check the standard for details.

#### Requirements for diesel fuel

Although conditions required for the diesel fuel are illustrated above, there are other requirements exerting a big influence on its service durability and service life.

Be sure to observe the following requirements for selecting fuel.

Sulfur content.....	2500 ppm or less
HFRR*.....	460 mm or less
Water content.....	0.05 wt% or less

\* HFRR (High-Frequency Reciprocating Rig.): An index showing lubricating properties of the fuel.

Sulfur content reacts to moisture to change into sulfuric acid after combustion.

Use of a fuel containing much sulfur content allows it to accelerate internal corrosion and wear.

In addition, much sulfur content quickens deterioration of engine oil allowing its cleaning dispersive property to be worse which results in acceleration of wear of sliding portions.

HFRR is an index that indicates lubricating property of a fuel.

Large value of the index means poor lubrication so that seizure of the machine components may result if such a fuel is used.

Since a fuel with high HFRR value also has lower viscosity, it can easily be leaked out.

If the fuel is mixed with the engine oil, the oil is diluted to deteriorate its lubricating property resulting in acceleration of wear.

Water content allows inside of the fuel tank to rust which in turn blocking the fuel line and the fuel filter.

**IMPORTANT :** *In cold weather, fill the fuel tank at the end of the day's work, in order to prevent the formation of condensation.*

This may also cause wear and seizure of the machine components.

If atmospheric temperature goes below the freezing point, moisture content in the fuel forms fine particle of ice allowing the fuel line to be clogged.

**IMPORTANT :** *Obtain table of analysis for the fuel you are using from the fuel supplier to confirm that it meets the criteria described above.*

**IMPORTANT :** *If a fuel which does not meet the specifications and the requirements for the diesel engine, function and performance of the engine will not be delivered. In addition, never use such a fuel because a breakdown of the engine or an accident may be invited.*

Guarantee will not be given to a breakdown caused by the use of a improper fuel.

Some fuels are used with engine oil or additives mixed together with diesel engine fuel.

In this case, do not use these fuels because damage to the engine may result as the fuel has been contaminated.

It is natural that the emission control regulation of 3rd-stage will not be cleared in case where a fuel that does not meet the specifications and the requirements is used.

Use the specified fuel for compliance of the exhaust gas control.

**IMPORTANT :** *If you use diesel fuel which contains much sulfur content more than 2500 ppm, be sure to follow the items below for the engine oil selection and maintenance of engine parts. Guarantee will not be given to breakdowns caused by not to follow these items.*

1 Selection of engine oil

Use API grade CF-4 or JASO grade DH-1.

2 Exchange the engine oil and engine oil filter element by the periodical interval reported on the Operator's Manual.

3 Inspect and exchange the EGR (\*)parts and fuel injector parts of engine every 3000 hour of use.

\* EGR: Exhaust Gas Recirculation

## Maintenance of fuel filters

Be sure to use the genuine fuel filters.

The fuel injection system is precisely constructed and the genuine filter employs finer mesh than conventional filters to improve protection of machine equipment.

If a filter with coarse mesh is used, foreign object passing through the filter enters into the engine so that machine equipment can wear out in a short period of time.

**IMPORTANT :** *If a fuel filter other than the genuine filter is used, guaranty will not be applied to a fault caused by the use of a wrong filter.*

Two kinds of fuel filter, the pre-filter and the main filter, are mounted on the machine.

Be sure to use the genuine fuel filters and replace them at the periodic intervals reported on the operator's Manual.

**IMPORTANT :** *Since the pre-filter also has a function of water separation, discharge water and sediment when the float reaches lower part of the filter elements. CHECK EVERY DAY before to start the engine.*

Time to replace filters may be advanced according to properties of the fuel being supplied.

- Therefore, take measures to prevent dust or water from being entered in the fuel tank when supplying fuel.
- When supplying fuel directly from a fuel drum can, leave the drum as it stands for a long period of time to supply clean fuel standing above a precipitate.
- If it is hard to leave the drum for a long period of time, install a fuel strainer and a water separator before the fuel tank of the machine to supply clean fuel.

Water drain cock is provided on the bottom side of the fuel tank.

- Drain water before starting the engine every morning.
- In addition, remove the cover under the tank once a year to clean up inside of the tank.

## **Fuel storage**

Long storage can lead to the accumulation of impurities and condensation in the fuel. Engine trouble can often be traced to the presence of water in the fuel.

The storage tank must be placed outside and the temperature of the fuel should be kept as low as possible. Drain off water and impurities regularly.

## **Anti-freeze/Anti-corrosion**

Use anti-freeze in all seasons to protect the cooling system from corrosion and all risk of freezing.

CASE/AKCELA: PREMIUM ANTI-FREEZE (MS 1710)

For areas where the temperature goes down to -38°C (-36.4°F), mix 50/50 with water.

**IMPORTANT** : *Do not mix products of a different origin or brand. The same product must be used when topping up the system.*

## **Environment**

Before carrying out any maintenance operation on this machine and before disposing of used fluids or lubricants, always think of the environment. Never throw oil or fluid on the ground and never place it in leaking receptacles.

Contact your local ecological recycling centre or your CASE Dealer to obtain information on the correct method of disposing of these lubricants.

## **Plastic and resin parts**

When cleaning plastic parts, the console, the instrument panel, the indicators etc... avoid using petrol, kerosene, paint solvents etc... Use only water, soap and a soft cloth.

The use of petrol, kerosene, paint solvents etc... causes discoloration, cracks or deformation of these parts.

# SPECIFICATIONS

## Main data

Model name ..... CX160B or CX180B Hydraulic Excavator  
 Operating weight  
     CX160B ..... 17000 kg (37479 lbs)  
     CX180B ..... 17900 kg (39463 lbs)  
 Engine output ..... 89.2 kW / 2200 rpm

## Performance

Swing speed ..... 11.5 Tr/min.  
 Travel speed  
     CX160B ..... Low Speed 2.8 km/h (1.74 mph)  
     CX180B ..... Low Speed 2.3 km/h (1.43 mph)  
     CX160B ..... High Speed 5.4 km/h (3.35 mph)  
     CX180B ..... High Speed 4.0 km/h (2.48 mph)  
 Maximum drawbar pull  
     CX160B ..... 161 kN (36194.24 lbf)  
     CX180B ..... 190 kN (42713.7 lbf)  
 Grade ability ..... 70% (35°)  
 Ground pressure  
     CX160B ..... 47 kPa (500 mm (19.68 in) grouser shoe)  
     CX160B/CX180B ..... 40 kPa (600 mm (23.62 in) grouser shoe)  
     CX160B/CX180B ..... 35 kPa (700 mm (27.56 in) grouser shoe)  
     CX180B ..... 31 kPa (800 mm (31.50 in) grouser shoe)

## Complete machine dimensions

CX160B (Standard boom)	Arm (dipper)		
	2620 mm (103.15 in)	2220 mm (87.40 in)	3050 mm (120.08 in)
Lenght (without attachment)	4410 mm (173.62 in)	4410 mm (173.62 in)	4410 mm (173.62 in)
Lenght (with attachment)	8440 mm (332.22 in)	8490 mm (334.25 in)	8520 mm (335.43 in)
Height (with attachment)	2960 mm (116.53 in)	3000 mm (118.11 in)	3130 mm (123.23 in)

CX160B (Articulated boom)	Arm (dipper)		
	2620 mm (103.15 in)	2220 mm (87.40 in)	3050 mm (120.08 in)
Lenght (without attachment)	4410 mm (173.62 in)	4410 mm (173.62 in)	4410 mm (173.62 in)
Lenght (with attachment)	8330 mm (327.95 in)	8365 mm (329.33 in)	8365 mm (329.33 in)
Height (with attachment)	2950 mm (116.14 in)	2950 mm (116.14 in)	3025 mm (119.09 in)

CX180B	Arm (dipper)		
	2620 mm (103.15 in)	2220 mm (87.40 in)	3050 mm (120.08 in)
Lenght (without attachment)	4500 mm (177.17 in)	4500 mm (177.17 in)	4500 mm (177.17 in)
Lenght (with attachment)	8440 mm (332.22 in)	8490 mm (334.25 in)	8520 mm (335.43 in)
Height (with attachment)	2960 mm (116.53 in)	3000 mm (118.11 in)	3120 mm (122.83 in)

## Main body dimensions

Main body width .....	See machine overall dimensions
Upper side swing body width.....	2540 mm (100 in)
Cab width .....	1000 mm (39.37 in)
Main body height	
CX160B.....	2950 mm (116.14 in)
CX180B.....	2960 mm (116.53 in)
Tail swing radius .....	2450 mm (96.46 in)
Swing body tail distance.....	2410 mm (94.88 in)
Swing body rear section bottom height	
CX160B.....	1020 mm (40.16 in)
CX180B.....	1040 mm (40.94 in)
Distance between tumblers	
CX160B.....	3190 mm (125.59 in)
CX180B.....	3370 mm (132.68 in)
Overall track length	
CX160B.....	3990 mm (157.09 in)
CX180B.....	4170 mm (164.17 in)
Width of track shoe	
CX160B.....	600 mm (23.62 in) (Optional: 500 mm (19.68 in), 700 mm (27.56 in)
CX180B.....	600 mm (23.62 in) (Optional: 700 mm (27.56 in), 800 mm (31.50 in)
Minimum ground clearance (To bottom of lower frame)	
CX160B.....	440 mm (17.32 in)
CX180B.....	490 mm (19.29 in)

## Engine

Name.....	ISUZU, 4JJ1X
Type: .....	4-cycle, water-cooled, overhead camshaft, vertical in-line, direct injection type (electronic control), with turbocharger.
No. of cylinders - bore x stroke.....	4 - Ø95.4 mm x 104.9 mm (3.76 x 4.13 in)
Displacement.....	2.999 L (0.792 gal)
Compression ratio .....	17.5
Rated output.....	89.2 kW / 2200 min <sup>-1</sup>
Maximum torque.....	391 N.m (288.39 lb-ft) / 1800 min <sup>-1</sup>
Engine dimensions (LxWxH).....	926.4x763x891.8 mm (36.47 x30.04x35.11 in)
Oil pan .....	All direction 0.61 rad, inclinable
Oil pan capacity.....	Maximum: 15 L (3.92 gal) Minimum: 11 L (2.91 gal) (excluding oil filter)
Direction of rotation .....	Right (as seen from fan)
Starter, reduction type.....	.24 V, 4 kW
Alternator, AC type .....	24 V, 50 A
Battery.....	2 x 12V, 92 Ah/5 Hr

## Cooling system

Fan type.....	Ø 550 mm (21.65 in), suction type - 8 blades, plastic with belt mouth-type fan guide
Pulley ratio.....	0.95 (reduction)
Radiator	
Fin type .....	wavy
Fin pitch .....	2.0 mm (0.078 in)
Oil cooler	
Fin type .....	wavy
Fin pitch .....	1.75 mm (0.069 in)
Inter-cooler	
Fin type .....	triangular straight
Fin pitch .....	2.0 mm (0.078 in)
Fuel cooler	
Fin type .....	wavy
Fin pitch .....	2.0 mm (0.078 in)
Coolant capacity.....	6 L (1.58 gal) (engine only)

## Capacity of coolant and lubricants

Coolant.....	14.6 L (3.86 gal)
Fuel .....	300 L (79.5 gal)
Lubricant for engine .....	17 L (4.49 gal)
Lubricant for travel reduction gear (per side)	
CX160B .....	5.8 L (1.53 gal)
CX180B .....	5 L (1.32 gal)
Lubricant for swing reduction gear (per side).....	5 L (1.32 gal)
Hydraulic oil.....	165 L (43.59 gal)
Capacity of hydraulic oil tank .....	90 L (23.77 gal)

## Hydraulic oil filter

Suction filter (inside tank).....	150 mesh
Return filter (inside tank).....	6 µm
Pilot line filter (inside housing) .....	8 µm

## Fuel filter

Main filter.....	4 µm
Pre-filter.....	10 µm

## Operating devices

### Operator's seat

Location: left side

Structure: Adjustable forward and back and up and down, reclining mechanism, with seat suspension.

### Cab

Sealed steel type, all reinforced glass.

### Levers and pedals

For travel use: Lever and pedal type (hydraulic pilot type) (x2)

For operating machine use: Lever type (hydraulic pilot type) (x2)

### Instruments and switches

Work mode select switch: 3 modes (SP / super power, H / heavy duty, A / automatic)

Travel mode select switch: Low-speed / high-speed switch type

One-touch idle: Knob switch type

Engine emergency stop: Switch type

### Monitor device

Machine status display (full-dot liquid crystal)

Work mode selection status: SP / H / A

### Instruments (full-dot liquid crystal, except for hour meter)

Fuel gauge: bar graph indicator

Engine coolant temperature gauge: bar graph indicator

Hydraulic oil temperature gauge: bar graph indicator

Hour meter: digital type

Machine Status and Warning Alarms (full-dot liquid crystal and warning tone) \*Items have a warning alarm

Over heat*	Battery charge*	Faulty electrical system*
Refill fuel*	Engine oil pressure*	Refill coolant*
Engine preheat	Auto warm-up	Air cleaner clogged
Anti-theft device triggered	Faulty engine system	Engine emergency stop

### Lighting

Working light	Tank:	24V, 70W (x1)
	Boom:	24V, 70W (x1)
	Cab:	24V, 70W (x2)
Interior light		24V, 10W (x1)

Horn: electric horn (x2)

Other

Wiper with intermittent function, Window washer, Air conditioner, Rear view mirrors (left and right), DC converter,

Clock

## Hydraulic system

Hydraulic pump drive system, directly coupled to the engine (no transmission)

### Main pump

Manufacturer .....	Kawasaki
Pump type .....	double variable displacement piston pump
Displacement volume .....	65.2 cm <sup>3</sup> (3.98 cu in) x 2 /rev
Rated operating pressure .....	34.3 MPa (4975 psi)
Maximum operating pressure .....	36.3 MPa (5265 psi)
Input revolution speed .....	2200 min <sup>-1</sup>
Maximum discharge flow .....	142.5 L/min (37.64 gpm) x 2 at 2200 min <sup>-1</sup>

### Pilot pump

Pump type .....	Gear pump
Displacement volume .....	10 cm <sup>3</sup> (0.61 cu in)/rev
Operating pressure .....	3.92 MPa (568 psi)
Maximum flow .....	22 L/min (5.81 gpm) (at 2200 min <sup>-1</sup> )

### Control method

- Hydraulic simultaneous constant output control.
- Maximum flow adjustment control through external commands (negative control).
- Setting horsepower adjustment control through external command current.

### Control Valve

Model; 4-spool section: integrated (1) or 5-spool section: integrated (1)	
Operation method: hydraulic pilot method: travel, swing and operating machine	
Maximum flow .....	143 L / min (37.78 gpm) (at 2200 min <sup>-1</sup> )
Main relief set pressure .....	standard; 34.3 MPa (4975 psi), power boost 36.3 MPa (5265 psi)
Overload set pressure .....	when boom down; 32.3 MPa (4685 psi)
.....	other: 38.2 MPa (5540 psi)
Foot relief set pressure .....	2.55 MPa (369.85 psi)

### Functions

- Straight travel circuit
- Boom up / arm 2 pumps internal flow
- Boom and arm load holding circuit
- Boom-down regenerative circuit
- Bucket-close regenerative circuit
- Arm-in forced regenerative circuit
- Swing priority variable orifice (for arm operation)
- 2 pumps flow
- Variable foot relief

### Hydraulic Cylinders

#### Boom cylinder (x2)

Cylinder bore .....	Ø115 mm (Ø4.53 in)
Rod diameter .....	Ø80 mm (Ø3.15 in)
Maximum retracted length .....	1698 mm (66.85 in)
Stroke .....	1179 mm (46.42 in)

#### Articulated boom cylinder

Cylinder bore .....	Ø140 mm (Ø5.51 in)
Rod diameter .....	Ø90 mm (Ø3.54 in)
Maximum retracted length .....	1385 mm (54.53 in)
Stroke .....	840 mm (33.07 in)

#### Arm (dipper) cylinder

Cylinder bore .....	Ø125 mm (Ø4.92 in)
Rod diameter .....	Ø90 mm (Ø3.54 in)
Maximum retracted length .....	1830 mm (72.05 in)
Stroke .....	1280 mm (50.39 in)

#### Bucket cylinder

Cylinder bore .....	Ø105 mm (Ø4.13 in)
Rod diameter .....	Ø75 mm (Ø2.95 in)
Maximum retracted length .....	1507 mm (59.33 in)
Stroke .....	985 mm (38.78 in)

Rotating Joint

Operating pressure

High pressure passage (ABCD) .....	34.3 MPa (4975 psi)
Drain port (E) .....	0.5 MPa (72.52 psi)
Pilot port (F) .....	3.9 MPa (566 psi)

Flow

High pressure passage (ABCD) .....	234 L/min (61.82 gpm)
Drain port (E) .....	10 L/min (2.64 gpm)
Pilot port (F) .....	21 L/min (5.55 gpm)

Port A; forward right .....	G3/4
Port B; forward left .....	G3/4
Port C; backward right .....	G3/4
Port D; backward left .....	G3/4
Port E; drain port .....	G1/2
Port F; pilot port .....	G1/4

Solenoid Valve

Maximum flow .....	P -> B: 25 L/min (6.60 gpm) Other: 5 L/min (1.32 gpm)
Rated pressure .....	4.5 MPa (652.67 psi)

Port size

P, T, B port .....	G3/8
C1, C2, C3, C4, C5 port .....	G1/4

Solenoid specifications

Operating voltage .....	DC 20 to 32 V
Power consumption .....	17 W max.

Hand control valve

Manufacturer .....	Kawasaki
Operating pressure .....	3.92 MPa (569 psi)
Secondary pressure, primary short type .....	0.64 to 2.45 MPa (92.82 to 355.34 psi)
Operating angle	
Ports 1, 3 .....	19°
Ports 2, 4 .....	25°

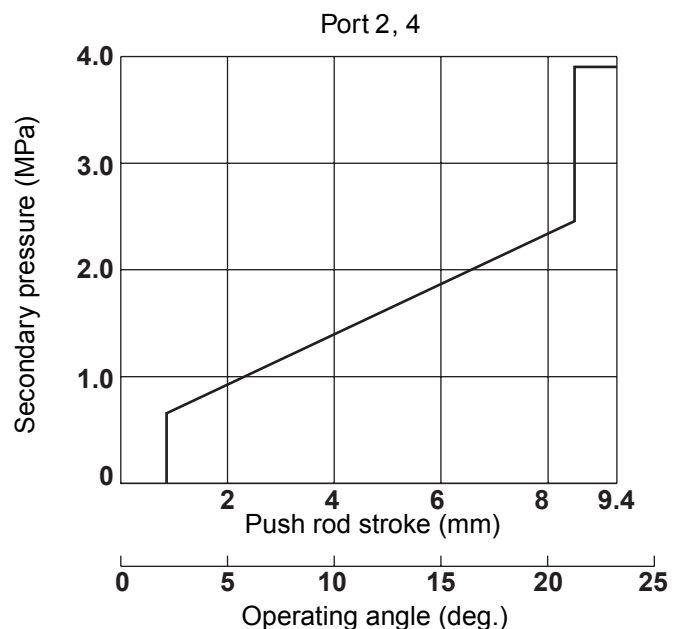
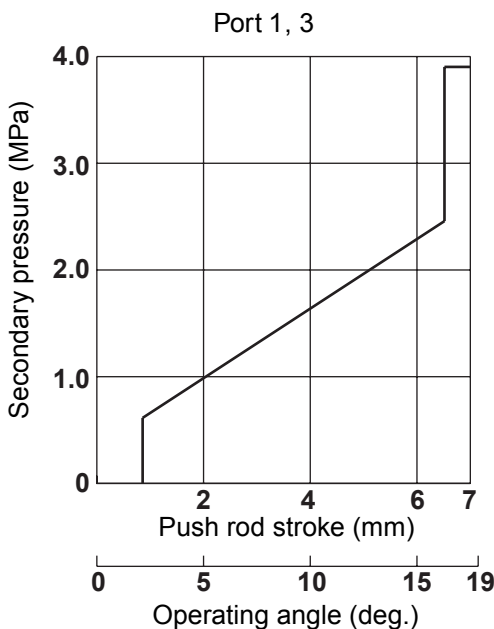

RST-03-01-001B

Foot control valve

Manufacturer .....	Kawasaki
Operating pressure .....	3.92 MPa (569 psi)
Secondary pressure, primary short type .....	0.64 to 2.45 MPa (92.82 to 355.34 psi)
Operating angle .....	12.4°

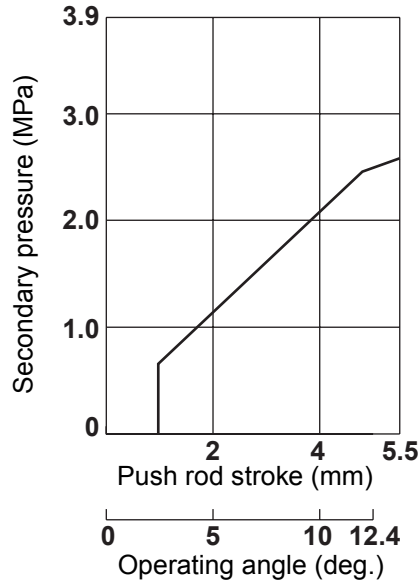

RST-03-01-001D

**Swing unit**

Swing circle .....	Swing bearing type (with internal gear)
Swing parking brake .....	Mechanical lock (operational lever linkage type)
Swing hydraulic motor .....	Fixed displacement piston motor
Displacement .....	151 cm <sup>3</sup> (9.21 cu in)/rev
Operating pressure .....	27.9 MPa (4046 psi)
Operating flow .....	143 L/min (37.78 gpm)
Mechanical brake torque .....	821.5 Nm (605.91 lb-ft) min.
Brake off pressure .....	3.2 MPa (464.12 psi) max.
Relief valve set pressure .....	27.9 MPa (4046 psi) max.
Reduction gear .....	Planetary gear 2-stage reduction gear
Reduction ratio .....	13.338

**Travel lower body**

Travel hydraulic motor (x2) .....	Variable displacement piston motor, automatic 2-speed switch-over with parking brake
Displacement	
CX160B .....	143.5/72.8 cm <sup>3</sup> (8.76/4.44 cu in)/rev
CX180B .....	181.3/112.6 cm <sup>3</sup> (11.06/6.87 cu in)/rev
Operating pressure .....	34.3 MPa (4975 psi)
Operating flow .....	143 L/min (37.78 gpm)
Brake torque	
CX160B .....	25.1 KNm (18512.8 lb-ft) min. (including reduction gear)
CX180B .....	20.9 KNm (15415 lb-ft) min. (including reduction gear)
Relief valve set pressure .....	35.3 MPa (5119.83 psi)
Automatic 2-speed switch-over pressure	
CX160B .....	25 MPa (3625.94 psi)
CX180B .....	25.5 MPa (3698.46 psi)
Reduction gear .....	Planetary gear 2-stage reduction gear
Reduction ratio .....	43.246
Travel brake .....	Hydraulic lock
Parking brake .....	Mechanical lock (travel lever linkage type)

## Track shoe

Model .....	Assembly type triple grouser shoe
Number of shoes (per side)	
CX160B .....	44
CX180B .....	51
Shoe width	
Standard .....	600 mm (23.62 in)
Optional CX160B .....	500 mm (19.68 in), 700 mm (27.56 in)
Optional CX180B .....	700 mm (27.56 in), 800 mm (31.50 in)
Grouser height .....	26 mm (1.02 in)
Link pitch .....	190 mm (7.48 in)

## Roller

Number of upper rollers (per side) .....	2
Number of lower rollers (per side)	
CX160B .....	7
CX180B .....	9

Track belt tension adjuster .....	Grease cylinder type (with cushion spring)
Mounting length of spring	
CX160B .....	445 mm (17.52 in)
CX180B .....	556 mm (21.89 in)

**Work Unit**

Model ..... Backhoe attachment  
 Components / dimensions / working dimensions

CX160B (Standard boom)	Standard boom		
	Standard arm	Short arm	Long arm
Arm (dipper) length	2620 mm (103.15 in)	2220 mm (87.40 in)	3050 mm (120.08 in)
Boom length (Standard boom spec.)	5150 mm 202.75 in		
Bucket radius	1350 mm 53.15 in		
Bucket wrist angle	178°		
Maximum digging radius	9040 mm 355.90 in	8670 mm 341.34 in	9380 mm 369.29 in
Maximum digging radius at ground line	8870 mm 349.21 in	8500 mm 334.64 in	9220 mm 362.99 in
Maximum digging depth	6060 mm 238.58 in	5460 mm 214.96 in	6490 mm 255.51 in
Maximum vertical straight wall digging depth	5080 mm 200.00 in	4720 mm 185.83 in	5220 mm 205.51 in
Maximum digging height	9240 mm 363.78 in	9010 mm 354.72 in	9290 mm 365.75 in
Maximum dump height	6610 mm 260.24 in	6380 mm 251.18 in	6690 mm 263.39 in
Minimum swing radius at front	2990 mm 117.72 in	2980 mm 117.32 in	2980 mm 117.32 in
Height for minimum swing radius at front	7140 mm 281.10 in	7160 mm 281.89 in	7160 mm 281.89 in

CX160B (Articulated boom)	Articulated boom		
	Standard arm	Short arm	Long arm
Arm (dipper) length	2620 mm (103.15 in)	2220 mm (87.40 in)	3050 mm (120.08 in)
Boom length (Articulated boom spec.)	4980 mm 196.06 in		
Bucket radius	1350 mm 53.15 in		
Bucket wrist angle	178°		
Maximum digging radius	8950 mm 352.36 in	8570 mm 337.40 in	9310 mm 366.53 in
Maximum digging radius at ground line	8780 mm 345.67 in	8390 mm 330.31 in	9140 mm 359.84 in
Maximum digging depth	5620 mm 221.26 in	5240 mm 206.30 in	6030 mm 237.40 in
Maximum vertical straight wall digging depth	4170 mm 164.17 in	4260 mm 167.72 in	4580 mm 180.31 in
Maximum digging height	10250 mm 403.54 in	9910 mm 390.16 in	10490 mm 412.99 in
Maximum dump height	7550 mm 297.24 in	7220 mm 284.25 in	7790 mm 306.69 in
Minimum swing radius at front	2080 mm 81.89 in	2160 mm 85.04 in	2160 mm 85.04 in
Height for minimum swing radius at front	7470 mm 294.09 in	7510 mm 295.67 in	7510 mm 295.67 in

CX180B	Standard boom		
	Standard arm	Short arm	Long arm
Arm (dipper) length	2620 mm (103.15 in)	2220 mm (87.40 in)	3050 mm (120.08 in)
Boom length (Standard boom spec.)	5150 mm 202.75 in		
Bucket radius	1350 mm 53.15 in		
Bucket wrist angle	178°		
Maximum digging radius	9040 mm 355.90in	8670 mm 341.34 in	9380 mm 369.29 in
Maximum digging radius at ground line	8870 mm 349.21 in	8500 mm 334.64 in	9220 mm 362.99 in
Maximum digging depth	6040 mm 237.79 in	5850 mm 230.31 in	6470 mm 254.72 in
Maximum vertical straight wall digging depth	5070 mm 199.61 in	4760 mm 187.40 in	5200 mm 204.72 in
Maximum digging height	9250 mm 364.17 in	9020 mm 355.12 in	9300 mm 366.14 in
Maximum dump height	6630 mm 261.02 in	6400 mm 251.97 in	6710 mm 264.17 in
Minimum swing radius at front	2990 mm 117.72in	2980 mm 117.32 in	2980 mm 117.32 in
Height for minimum swing radius at front	7150 mm 281.50 in	7170 mm 282.28 in	7180 mm 282.68 in

### Digging force (ISO 6015)

	Arm (dipper)		
	2620 mm (103.15 in)	2220 mm (87.40 in)	3050 mm (120.08 in)
Arm (dipper) digging force (standard)	79 kN (17759.9 lbf)	90 kN (20232.8 lbf)	72 kN (16186.2 lbf)
Arm (dipper) digging force (power up)	84 kN (18883.9 lbf)	95 kN (21356.8 lbf)	77 kN (17310.3 lbf)
Bucket digging force (standard)	112 kN (25178.6 lbf)	112 kN (25178.6 lbf)	112 kN (25178.6 lbf)
Bucket digging force (power up)	118 kN (26527.4 lbf)	118 kN (26527.4 lbf)	118 kN (26527.4 lbf)

## COMPONENT WEIGHT

### Major component weight

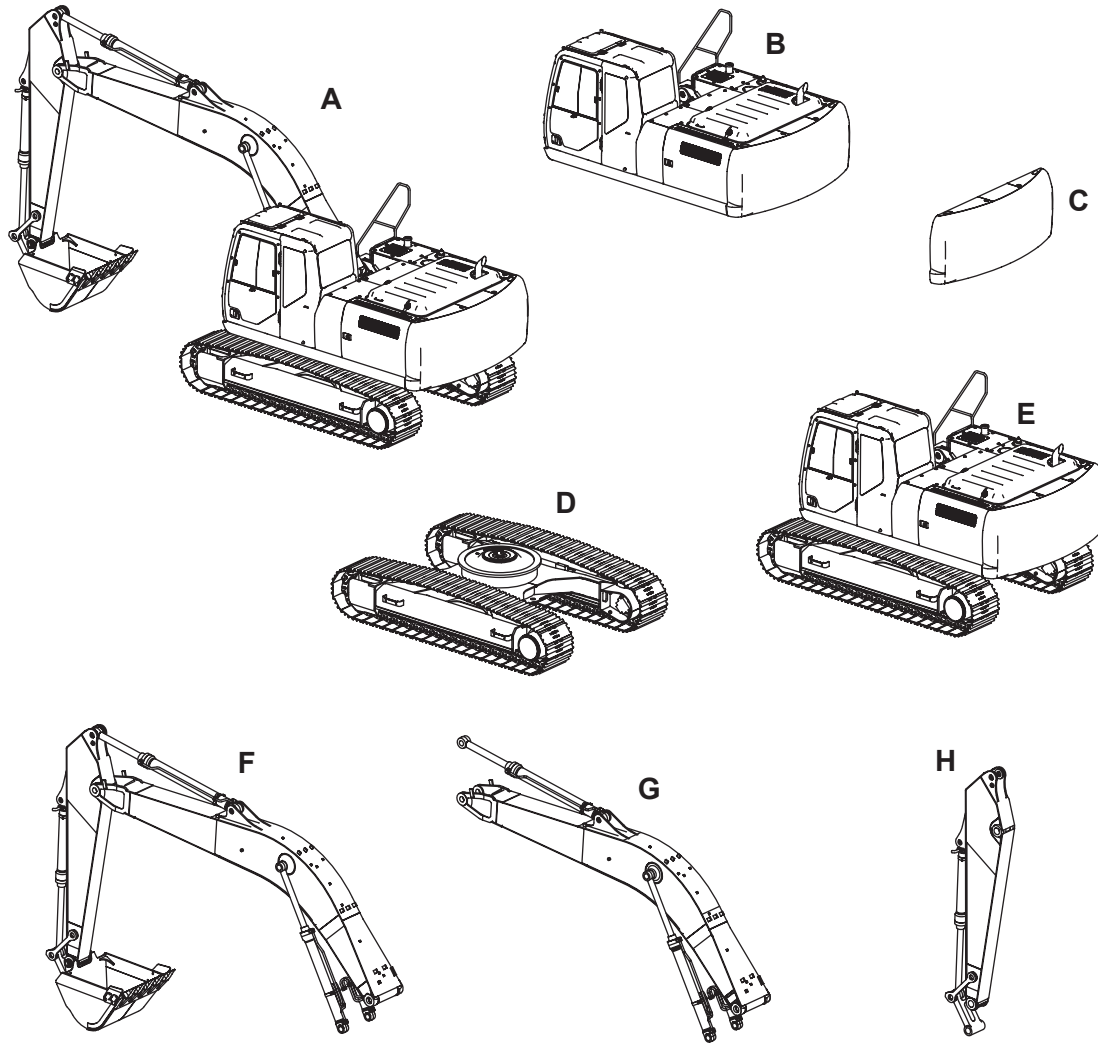

RST-11-01-001A

Weight information is approximate

A) Operating weight	
CX160B .....	17000 kg (37479 lbs)
CX180B .....	17900 kg (39463 lbs)
B) Upper mechanism (including counterweight and turntable bearing)	
CX160B .....	7310 kg (16116 lbs)
CX180B .....	7560 kg (16667 lbs)
C) Counterweight	
CX160B, standard boom .....	3170 kg (6989 lbs)
CX160B, articulated boom - CX180B .....	3420 kg (7540 lbs)
D) Lower mechanism (with standard grouser shoe)	
CX160B .....	6090 kg (13426 lbs)
CX180B .....	6700 kg (14771 lbs)
E) Main Unit Weighty	
CX160B .....	13860 kg (30556 lbs)
CX180B .....	14720 kg (32452 lbs)
F) Attachments	
CX160B .....	3030 kg (6680 lbs)
CX180B .....	3060 kg (6746 lbs)
G) Boom (including cylinders) .....	
	1550 kg (3417 lbs)
H) Arm (dipper) (including cylinders and linkage) .....	
	670 kg (1477 lbs)

## Other component weight

Engine .....	328 kg (723.1 lbs)
Air cleaner .....	5.4 kg (11.9 lbs)
Hydraulic pump .....	86 kg (189.6 lbs)
Attachment control valve	
CX160B, standard boom - CX180B .....	173 kg (381.4 lbs)
CX160B, articulated boom.....	196 kg (432.1 lbs)
Swing motor and reduction gear assembly .....	235 kg (518.1 lbs)
Travel motor and reduction gear assembly	
CX160B .....	260 kg (573.2 lbs)
CX180B .....	270 kg (595.2 lbs)
Rotary joint.....	30 kg (66.1 lbs)
Solenoid valve bank .....	6.7 kg (14.8 lbs)
Cushion valve.....	12.5 kg (27.6 lbs)
Hand control valve .....	1.9 kg (4.2 lbs)
Foot control valve .....	7.8 kg (17.2 lbs)
Standard boom.....	1032 kg (2275.2 lbs)
Standard arm (dipper).....	468 kg (1031.8 lbs)
Short arm (dipper).....	413 kg (910.5 lbs)
Long arm (dipper) .....	540 kg (1190.5 lbs)
Boom cylinder (one).....	157 kg (346 lbs)
Articulated boom cylinder.....	184 kg (405.7 lbs)
Arm (dipper) cylinder.....	201 kg (443 lbs)
Bucket cylinder .....	117 kg (258 lbs)
Fuel tank .....	107 kg (235.9 lbs)
Hydraulic oil tank.....	95 kg (209.4 lbs)
Turntable bearing .....	244 kg (537.9 lbs)
Muffler .....	13.5 kg (29.8 lbs)
Radiator total weight .....	79 kg (174.2 lbs)
Oil cooler.....	15.2 kg (33.5 lbs)
Radiator .....	9.9 kg (21.8 lbs)
Air cooler.....	4.6 kg (10.1 lbs)
Fuel cooler .....	0.7 kg (1.54 lbs)
Idler wheel.....	86.8 kg (191.4 lbs)
Upper roller .....	17.2 kg (37.9 lbs)
Lower roller .....	34.4 kg (75.8 lbs)
Recoil spring assembly	
CX160B .....	127 kg (280 lbs)
CX180B .....	155 kg (341.7 lbs)
Recoil spring	
CX160B .....	42.9 kg (94.6 lbs)
CX180B .....	67.6 kg (149 lbs)
Grease cylinder assembly .....	30.4 kg (67 lbs)
Threaded rod	
CX160B .....	25.3 kg (55.8 lbs)
CX180B .....	29.7 kg (65.5 lbs)
Yoke .....	25.6 kg (56.4 lbs)
Track chains (per side)	
500 mm (19.68 in)	
CX160B .....	1080 kg (2381 lbs)
600 mm (23.62 in)	
CX160B .....	1190 kg (2623.5 lbs)
CX180B .....	1260 kg (2778 lbs)
700 mm (27.56 in)	
CX160B .....	1400 kg (3086.5 lbs)
CX180B .....	1470 kg (3240.8 lbs)
800 mm (31.5 in)	
CX180B .....	1772 kg (3906.6 lbs)

## SPECIAL TORQUE SETTINGS

No.	Component	Screw	Wrench (mm)	Torque setting
1 *	Travel motor and reduction gear assembly	M16	24	267-312 Nm (197-230 lb-ft)
2 *	Drive sprocket	M16	24	267-312 Nm (197-230 lb-ft)
3 *	Idler wheel	M16	24	267-312 Nm (197-230 lb-ft)
4 *	Upper roller	M20	30	521-608 Nm (385-448 lb-ft)
5 *	Lower roller	M18	27	371-432 Nm (274-318 lb-ft)
6 *	Track guard	M18	27	400-462 Nm (295-341 lb-ft)
7	Shoe bolt	M20	30	820 Nm (604.8 lb-ft) + 120°
8	Counterweight	M33	50	1862-2058 Nm (1374-1517 lb-ft)
9	Turntable bearing (lower frame)	M20	30	468-545 Nm (346-402 lb-ft)
10	Turntable (swing frame)	M20	30	468-545 Nm (346-402 lb-ft)
11 *	Swing unit	M20	30	539-630 Nm (398-464 lb-ft)
12 *	Engine (engine mount)	M16	24	265-314 Nm (196-231 lb-ft)
13 *	Engine bracket	M12	19	64-74 Nm (47.20-54.58 lb-ft)
14	Radiator	M12	19	64-74 Nm (47.20-54.58 lb-ft)
15 *	Hydraulic pump	M10	17	64-74 Nm (47.20-54.58 lb-ft)
		M16		223-247 Nm (165-182 lb-ft)
16 *	Hydraulic reservoir	M16	24	232-276 Nm (172-203 lb-ft)
17 *	Fuel reservoir	M16	24	232-276 Nm (172-203 lb-ft)
18	Control valve	M16	24	330-360 Nm (244-265 lb-ft)
19 *	Hydraulic swivel	M12	19	88-107 Nm (65-78 lb-ft)
20		M16	24	109-127 Nm (81-93 lb-ft)
21	Cab	M16	24	245-294 Nm (181-216 lb-ft)
22	Battery	M10	17	20-29 Nm (14.75-21.39 lb-ft)

**NOTE:** Use Loctite 262 or an equivalent on retaining screws of those components marked with an asterisk (\*).

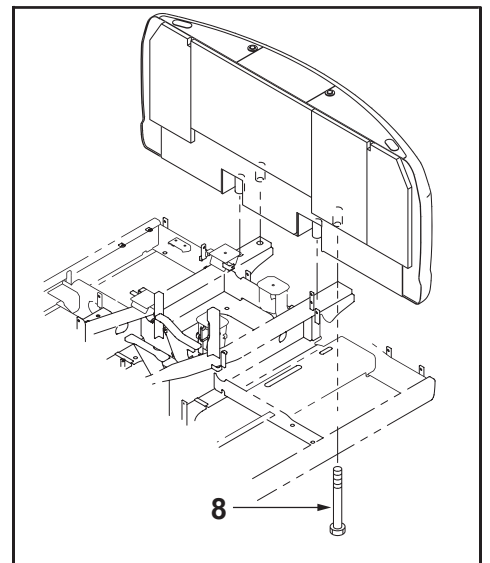
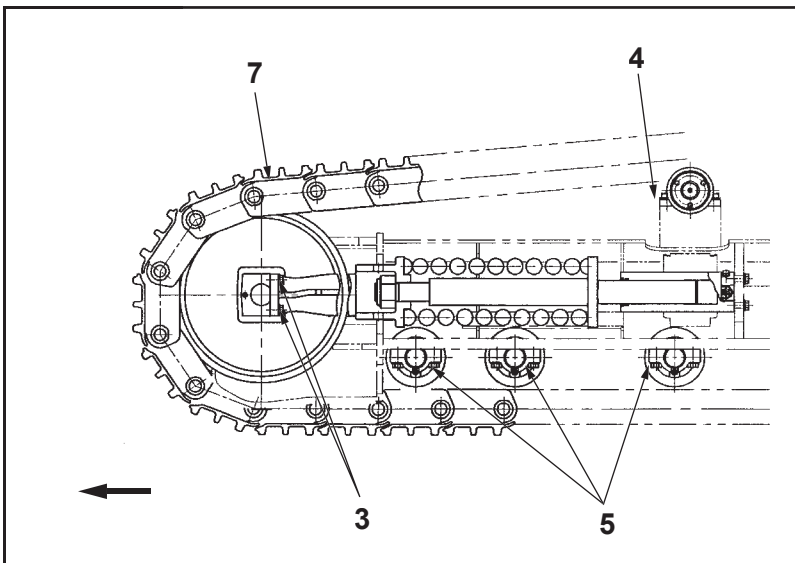
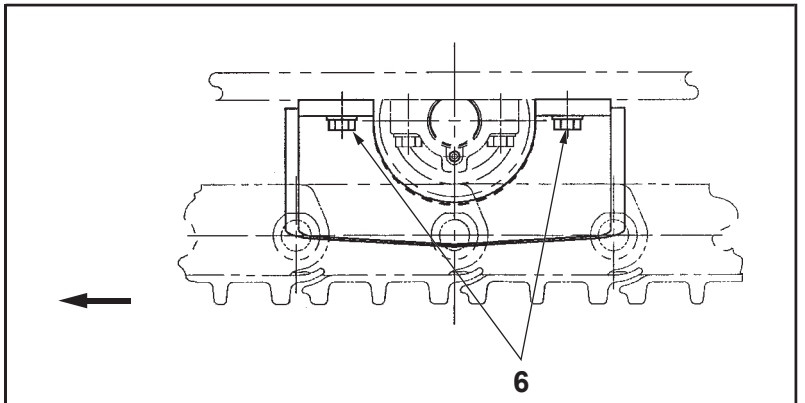
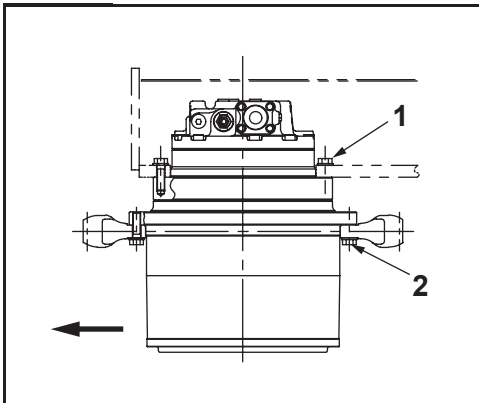
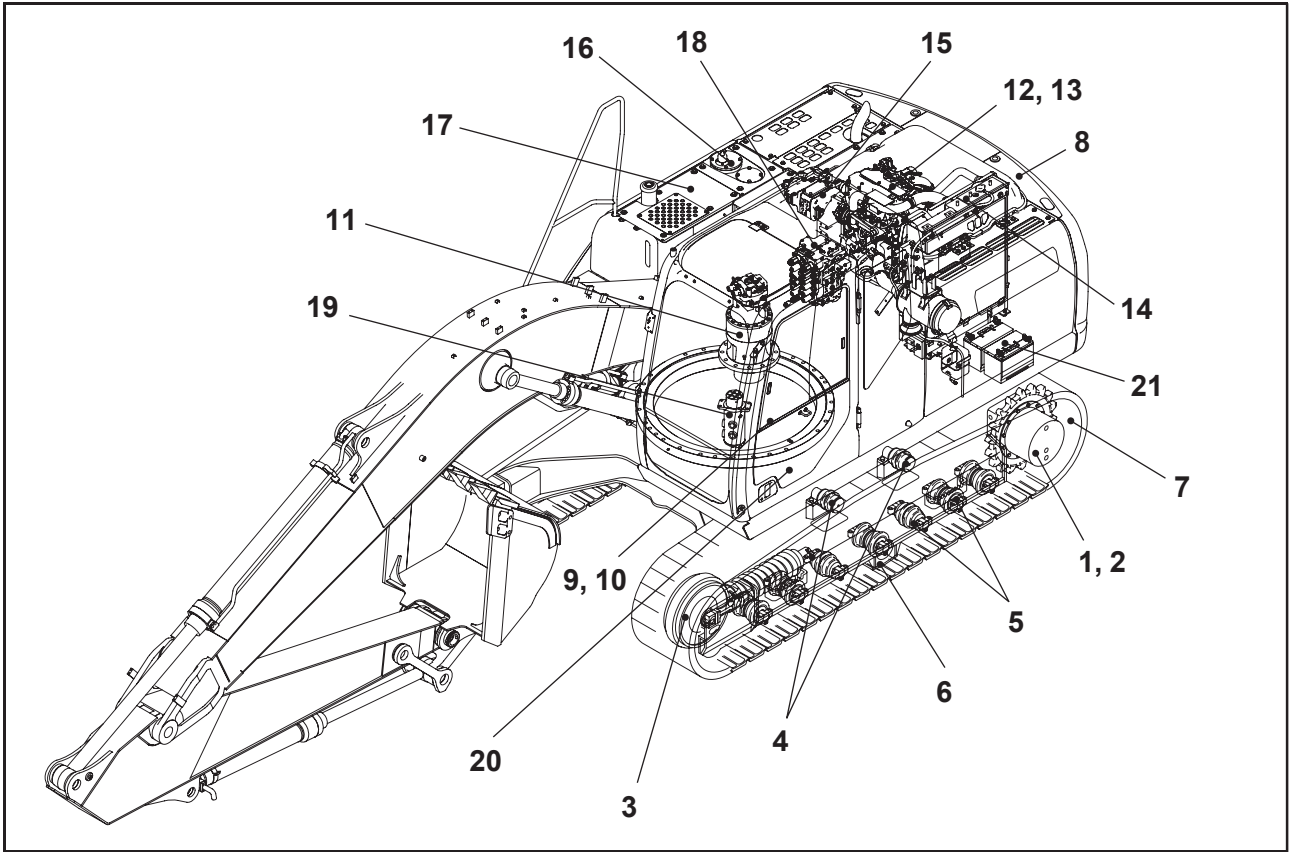

TORQUE\_1



**Suggest:**

**If the above button click is invalid.**

**Please download this document**

**first, and then click the above link**

**to download the complete manual.**

**Thank you so much for reading**

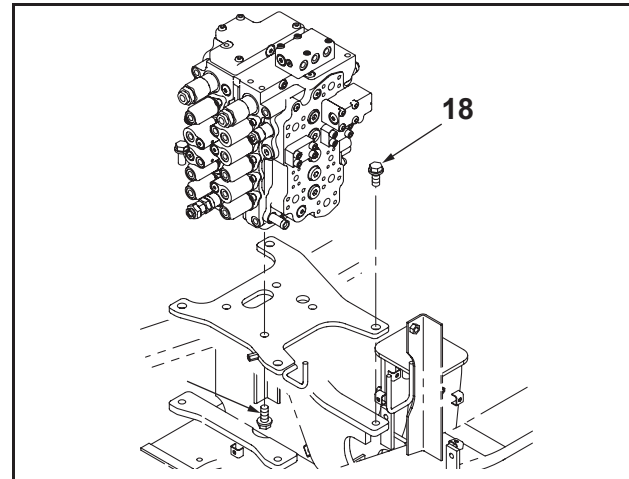
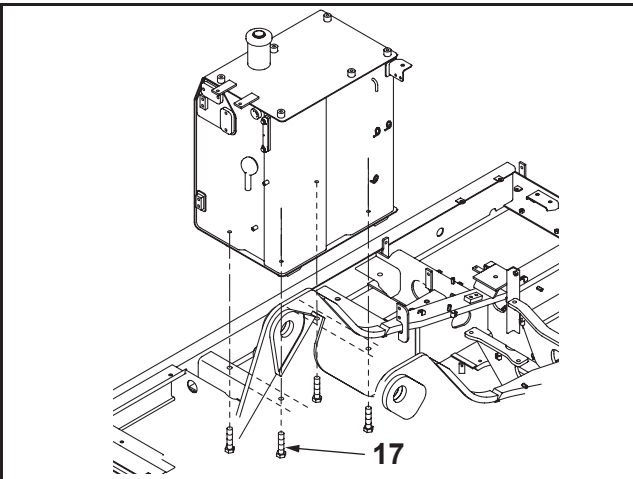
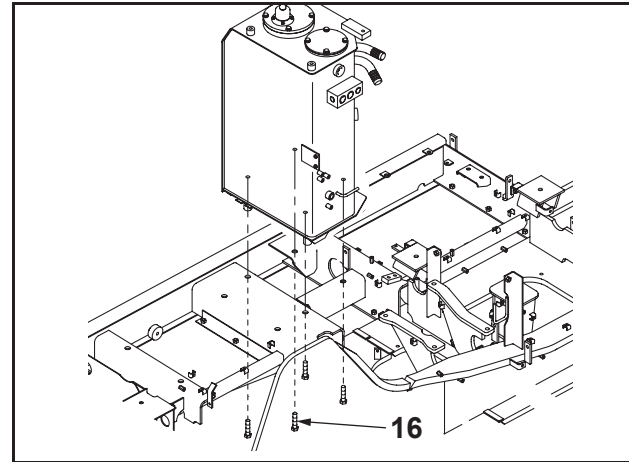
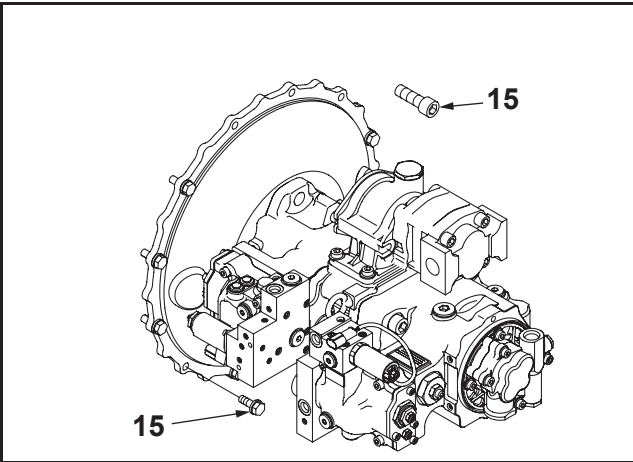
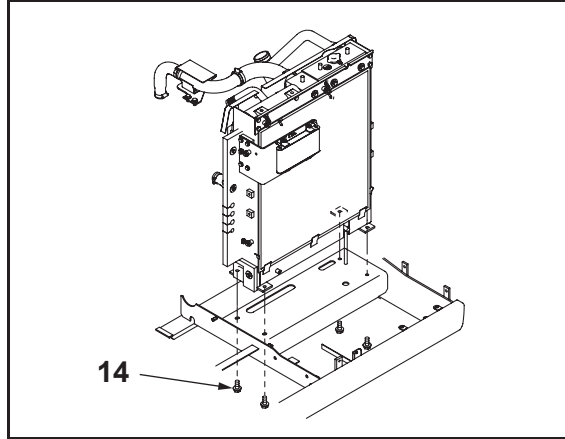
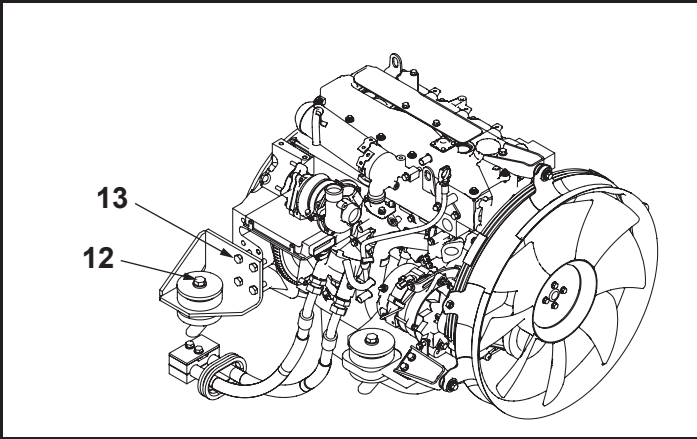
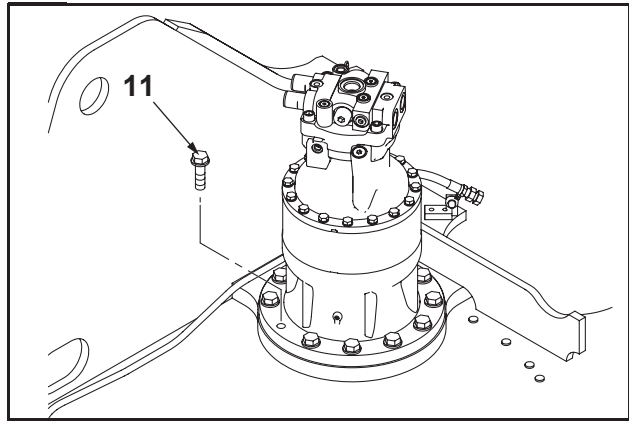
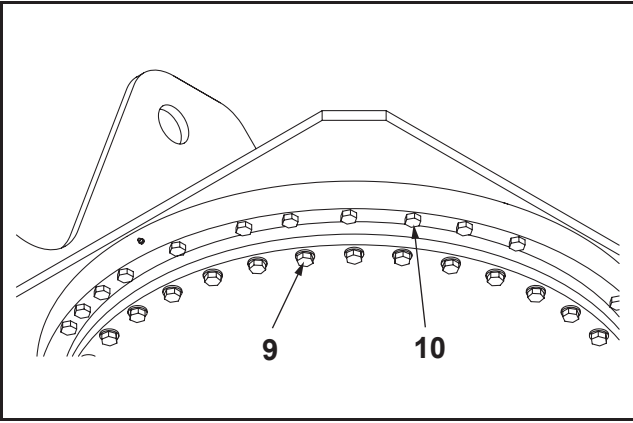

TORQUE\_2

**<https://www.ebooklibonline.com>**

Hello dear friend!

Thank you very much for reading.

Enter the link into your browser.

The full manual is available for immediate download.

**<https://www.ebooklibonline.com>**