

821F
921F
Tier 4
Wheel Loader

SERVICE MANUAL

Part number 84487565
1st edition English
April 2011



Section 1001

GENERAL TORQUE SPECIFICATIONS

TABLE OF CONTENTS

TORQUE SPECIFICATIONS - DECIMAL HARDWARE	3
TORQUE SPECIFICATIONS - METRIC HARDWARE	4
TORQUE SPECIFICATIONS - STEEL HYDRAULIC FITTINGS	5
TORQUE SPECIFICATIONS - STEEL HYDRAULIC FITTINGS	6

<https://www.ebooklibonline.com>

Hello dear friend!

Thank you very much for reading.

Enter the link into your browser.

The full manual is available for immediate download.

<https://www.ebooklibonline.com>

TORQUE SPECIFICATIONS - DECIMAL HARDWARE

Use the torques in this chart when special torques are not given. These torques apply to fasteners with both UNC and UNF threads as received from suppliers dry, or when lubricated with engine oil. Not applicable if special graphities, Molydisulfide greases, or other extreme pressure lubricants are used.

Grade 5 Bolts, Nuts, and Studs		
		
Size	Pound-Inches	Newton metres
1/4 inch	108 to 132	12 to 15
5/16 inch	204 to 252	23 to 28
3/8 inch	420 to 504	48 to 57
Size	Pound-Feet	Newton metres
7/16 inch	54 to 64	73 to 87
1/2 inch	80 to 96	109 to 130
9/16 inch	110 to 132	149 to 179
5/8 inch	150 to 180	203 to 244
3/4 inch	270 to 324	366 to 439
7/8 inch	400 to 480	542 to 651
1.0 inch	580 to 696	787 to 944
1-1/8 inch	800 to 880	1085 to 1193
1-1/4 inch	1120 to 1240	1519 to 1681
1-3/8 inch	1460 to 1680	1980 to 2278
1-1/2 inch	1940 to 2200	2631 to 2983

Grade 8 Bolts, Nuts, and Studs		
		
Size	Pound-Inches	Newton metres
1/4 inch	144 to 180	16 to 20
5/16 inch	288 to 348	33 to 39
3/8 inch	540 to 648	61 to 73
Size	Pound-Feet	Newton metres
7/16 inch	70 to 84	95 to 114
1/2 inch	110 to 132	149 to 179
9/16 inch	160 to 192	217 to 260
5/8 inch	220 to 264	298 to 358
3/4 inch	380 to 456	515 to 618
7/8 inch	600 to 720	814 to 976
1.0 inch	900 to 1080	1220 to 1465
1-1/8 inch	1280 to 1440	1736 to 1953
1-1/4 inch	1820 to 2000	2468 to 2712
1-3/8 inch	2380 to 2720	3227 to 3688
1-1/2 inch	3160 to 3560	4285 to 4827
NOTE: Use thick nuts with Grade 8 bolts.		

TORQUE SPECIFICATIONS - METRIC HARDWARE

Use the following torques when specifications are not given.

These values apply to fasteners with coarse threads as received from supplier, plated or unplated, or when lubricated with engine oil. These values do not apply if graphite or Molydisulfide grease or oil is used.

Grade 8.8 Bolts, Nuts, and Studs		
		
Size	Pound-Inches	Newton metres
M4	24 to 36	3 to 4
M5	60 to 72	7 to 8
M6	96 to 108	11 to 12
M8	228 to 276	26 to 31
M10	456 to 540	52 to 61
Size	Pound-Feet	Newton metres
M12	66 to 79	90 to 107
M14	106 to 127	144 to 172
M16	160 to 200	217 to 271
M20	320 to 380	434 to 515
M24	500 to 600	675 to 815
M30	920 to 1100	1250 to 1500
M36	1600 to 1950	2175 to 2600

Grade 10.9 Bolts, Nuts, and Studs		
		
Size	Pound-Inches	Newton metres
M4	36 to 48	4 to 5
M5	84 to 96	9 to 11
M6	132 to 156	15 to 18
M8	324 to 384	37 to 43
Size	Pound-Feet	Newton metres
M10	54 to 64	73 to 87
M12	93 to 112	125 to 150
M14	149 to 179	200 to 245
M16	230 to 280	310 to 380
M20	450 to 540	610 to 730
M24	780 to 940	1050 to 1275
M30	1470 to 1770	2000 to 2400
M36	2580 to 3090	3500 to 4200

Grade 12.9 Bolts, Nuts, and Studs

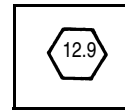

Usually the torque values specified for grade 10.9 fasteners can be used satisfactorily on grade 12.9 fasteners.

TORQUE SPECIFICATIONS - STEEL HYDRAULIC FITTINGS

37 Degree Flare Fitting			
Tube OD Hose ID	Thread Size	Pound- Inches	Newton metres
1/4 inch 6.4 mm	7/16-20	72 to 144	8 to 16
5/16 inch 7.9 mm	1/2-20	96 to 192	11 to 22
3/8 inch 9.5 mm	9/16-18	120 to 300	14 to 34
1/2 inch 12.7 mm	3/4-16	180 to 504	20 to 57
5/8 inch 15.9 mm	7/8-14	300 to 696	34 to 79
Tube OD Hose ID	Thread Size	Pound- Feet	Newton metres
3/4 inch 19.0 mm	1-1/16-12	40 to 80	54 to 108
7/8 inch 22.2 mm	1-3/16-12	60 to 100	81 to 135
1.0 inch 25.4 mm	1-5/16-12	75 to 117	102 to 158
1-1/4 inch 31.8 mm	1-5/8-12	125 to 165	169 to 223
1-1/2 inch 38.1 mm	1-7/8-12	210 to 250	285 to 338

Straight Threads with O-ring			
Tube OD Hose ID	Thread Size	Pound- Inches	Newton metres
1/4 inch 6.4 mm	7/16-20	144 to 228	16 to 26
5/16 inch 7.9 mm	1/2-20	192 to 300	22 to 34
3/8 inch 9.5 mm	9/16-18	300 to 480	34 to 54
1/2 inch 12.7 mm	3/4-16	540 to 804	57 to 91
Tube OD Hose ID	Thread Size	Pound- Feet	Newton metres
5/8 inch 15.9 mm	7/8-14	58 to 92	79 to 124
3/4 inch 19.0 mm	1-1/16-12	80 to 128	108 to 174
7/8 inch 22.2 mm	1-3/16-12	100 to 160	136 to 216
1.0 inch 25.4 mm	1-5/16-12	117 to 187	159 to 253
1-1/4 inch 31.8 mm	1-5/8-12	165 to 264	224 to 357
1-1/2 inch 38.1 mm	1-7/8-12	250 to 400	339 to 542

Split Flange Mounting Bolts		
Size	Pound- Inches	Newton metres
5/16-18	180 to 240	20 to 27
3/8-16	240 to 300	27 to 34
7/16-14	420 to 540	47 to 61
Size	Pound- Feet	Newton metres
1/2-13	55 to 65	74 to 88
5/8-11	140 to 150	190 to 203

TORQUE SPECIFICATIONS - STEEL HYDRAULIC FITTINGS

O-ring Face Seal End					O-ring Boss End Fitting or Lock Nut		
Nom. SAE Dash Size	Tube OD	Thread Size	Pound-Inches	Newton metres	Thread Size	Pound-Inches	Newton metres
-4	1/4 inch 6.4 mm	9/16-18	120 to 144	14 to 16	7/16-20	204 to 240	23 to 27
-6	3/8 inch 9.5 mm	11/16-16	216 to 240	24 to 27	9/16-18	300 to 360	34 to 41
-8	1/2 inch 12.7 mm	13/16-16	384 to 480	43 to 54	3/4-16	540 to 600	61 to 68
					Thread Size	Pound-Feet	Newton metres
-10	5/8 inch 15.9 mm	1-14	552 to 672	62 to 76	7/8-14	60 to 65	81 to 88
Nom. SAE Dash Size	Tube OD	Thread Size	Pound-Feet	Newton metres	1-1/16-12	85 to 90	115 to 122
					1-3/16-12	95 to 100	129 to 136
-12	3/4 inch 19.0 mm	1-3/16-12	65 to 80	90 to 110	1-5/16-12	115 to 125	156 to 169
-14	7/8 inch 22.2 mm	1-3/16-12	65 to 80	90 to 110	1-5/8-12	150 to 160	203 to 217
-16	1.0 inch 25.4 mm	1-7/16-12	92 to 105	125 to 140	1-7/8-12	190 to 200	258 to 271
-20	1-1/4 inch 31.8 mm	1-11/16-12	125 to 140	170 to 190			
-24	1-1/2 inch 38.1 mm	2-12	150 to 180	200 to 254			

Section 1002

FLUIDS AND LUBRICANTS

1002

TABLE OF CONTENTS

821F - CAPACITIES AND LUBRICANTS	3
921F - CAPACITIES AND LUBRICANTS	4
ENGINE OIL RECOMMENDATIONS	5
TRANSMISSION TEMPERATURE CHART	6
DIESEL FUEL SYSTEM	6
Fuel Storage	6
Specifications for Acceptable No. 2 Diesel Fuel	6
What is Selective Catalytic Reduction (SCR)?	7
Selective Catalytic Reduction (SCR) - Basic instructions	9
MAINTENANCE SCHEDULE	10
MAINTENANCE POINTS	12

821F - CAPACITIES AND LUBRICANTS

Engine Oil

Capacity with Filter Change	13.25 liters (14 U.S. Quarts)
Total system capacity	15.1 liters (16 U.S. Quarts)
Type of oil	Case AKCELA No. 1 engine oil see engine oil recommendations on page 4

Engine Cooling System

Capacity	30 liters (32 U.S. Quarts)
Type of Coolant	50% water and 50% Ethylene Glycol

Fuel Tank

Capacity	288 liters (76 U.S. Gallons)
Type of Fuel.....	See Diesel fuel specifications on page 5

DEF (Diesel Exhaust Fluid) Tank

Capacity	41.3 liters (43.6 U.S. Quarts)
----------------	--------------------------------

Hydraulic System

Hydraulic Reservoir Refill Capacity	90.8 liters (24.0 U.S. Gallons)
Total System Capacity	178 liters (47.0 U.S. Gallons)
Type of Oil	Case AKCELA Hy-Tran Ultra®

Transmission

Refill Capacity with Filter Change	34.1 liters (36 U.S. Quarts)
Type of Oil	Case Nexlore

Axles

Capacity	
Front.....	40.0 liters (42.3 U.S. Quarts)
Rear	40.0 liters (42.3 U.S. Quarts)
Type of Lubricant.....	Case Nexlore

NOTE: *DO NOT use an alternate oil in the axles. The brake components in the axles could be damaged as a result of using an alternate oil. Machines are shipped from the factory with break-in oil.*

Brake System

Type of Fluid (Same as Hydraulic System).....	Case AKCELA Hy-Tran Ultra®
---	----------------------------

921F - CAPACITIES AND LUBRICANTS

Engine Oil

Capacity with Filter Change 13.25 liters (14 U.S. Quarts)
Total system capacity 15.1 liters (16 U.S. Quarts)
Type of oil Case AKCELA No. 1 engine oil - see engine oil recommendations on page 4

Engine Cooling System

Capacity 30 liters (32 U.S. Quarts)
Type of Coolant 50% water and 50% Ethylene Glycol

Fuel Tank

Capacity 288 liters (76 U.S. Gallons)
Type of Fuel See Diesel fuel specifications on page 5

DEF (Diesel Exhaust Fluid) Tank

Capacity 41.3 liters (43.6 U.S. Quarts)

Hydraulic System

Hydraulic Reservoir Refill Capacity 110 liters (29.0 U.S. Gallons)
Total System Capacity 200 liters (53.0 U.S. Gallons)
Type of Oil Case AKCELA Hy-Tran Ultra®

Transmission

Refill Capacity with Filter Change 34.1 liters (36 U.S. Quarts)
Type of Oil Case Nexplore

Axles

Capacity
Front 42.0 liters (44.4 U.S. Quarts)
Rear 40.0 liters (42.3 U.S. Quarts)
Type of Lubricant Case Nexplore

NOTE: *DO NOT use an alternate oil in the axles. The brake components in the axles could be damaged as a result of using an alternate oil. Machines are shipped from the factory with break-in oil.*

ENGINE OIL RECOMMENDATIONS

Case AKCELA No. 1 Engine oil is recommended for use in your Case engine. Case AKCELA No. 1 Engine Oil will lubricate your engine correctly under all operating conditions.

If Case AKCELA No. 1 Multi-Viscosity Oil is not available, use only oil meeting API engine oil service category CH-4 (preferred) or CG-4.



BD03A102



See the chart below for recommended viscosity at ambient air temperature ranges.

NOTE: Do not put performance additives or other oil additive products in the engine crankcase. The oil change intervals given in this manual are according to tests with Case AKCELA lubricants.

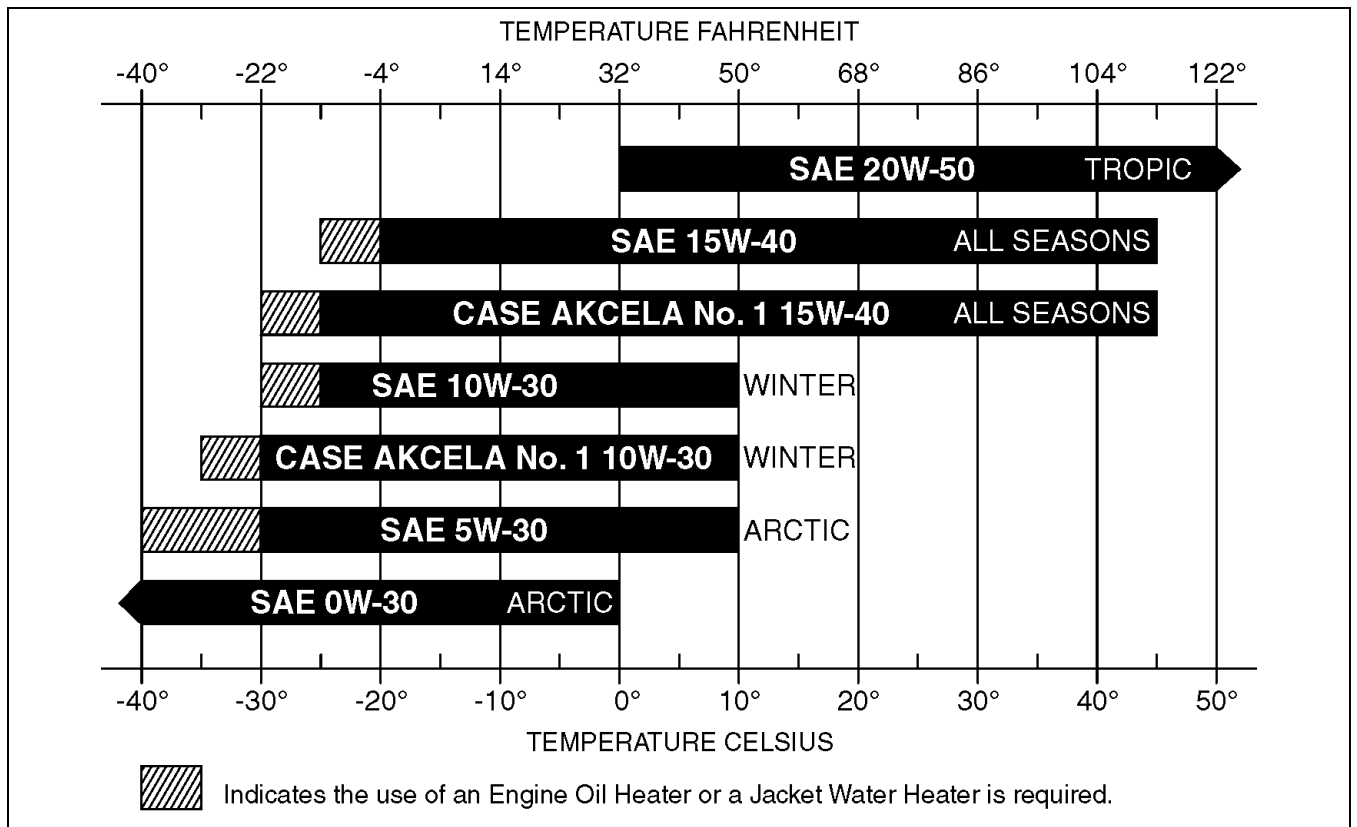

BC02N250

TRANSMISSION TEMPERATURE CHART

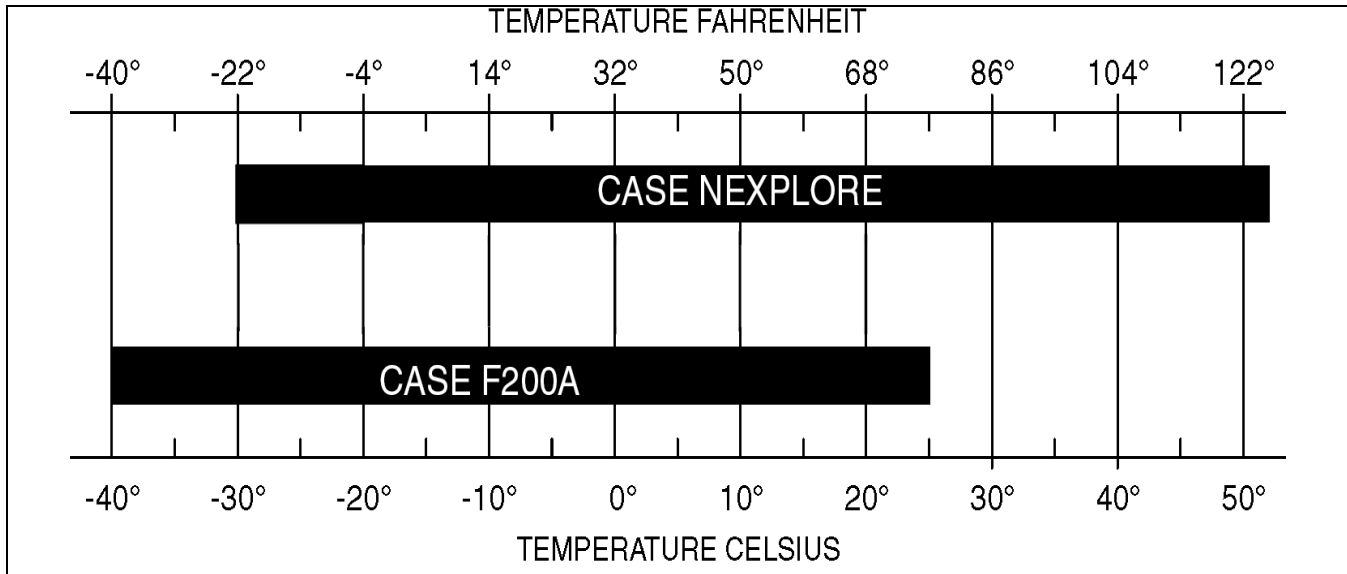

RCPH10WHL435BAH3

DIESEL FUEL SYSTEM

Use No. 2 diesel fuel in the engine of this machine. The use of other fuels can cause the loss of engine power and high fuel consumption.

In very cold temperatures, a mixture of No. 1 and No. 2 diesel fuels is temporarily permitted. See the following Note.

NOTE: See your fuel dealer for winter fuel requirements in your area. If the temperature of the fuel lowers below the cloud point (wax appearance point), wax crystals in the fuel will restrict the fuel filter and cause the engine to lose power or not start.

The diesel fuel used in this machine must meet the specifications as shown below in, "Specifications for Acceptable No. 2 Diesel Fuel", or "Specification D975-81" of the American Society for Testing and Materials.

Specifications for Acceptable No. 2 Diesel Fuel

API gravity, minimum	34
Flash point, minimum	60°C (140°F)
Cloud point (wax appearance point), maximum	-20°C (-5°F) See Note above
Pour point, maximum	-26°C (-15°F) See Note above
Distillation temperature, 90% point	282 to 338°C (540 to 640°F)
Viscosity, at 38°C (100°F)	
Centistokes	2.0 to 4.3
Cetane number, minimum	43 (45 to 55 for winter or high altitudes)
Water and sediment, by volume, maximum	0.05%

Fuel Storage

If you keep fuel in storage for a period of time, you can get foreign material or water in the fuel storage tank. Many engine problems are caused by water in the fuel.

Keep the fuel storage tank outside and keep the fuel as cool as possible. Remove water from the storage container at regular periods of time.

Fill the fuel tank at the end of the daily operating period to prevent condensation in the fuel tank.

What is Selective Catalytic Reduction (SCR)?

The main components of the SCR system include the SCR catalyst, the Diesel Exhaust Fluid (DEF)/AdBlue® injection unit, the DEF/AdBlue® tank, and the DEF/AdBlue® dosing control unit.

How does Selective Catalytic Reduction (SCR) work?

During combustion, harmful Nitrogen Oxide (NOx) molecules are formed in the exhaust. By injecting a DEF/AdBlue® solution into the exhaust prior to a catalyst, the NOx can be converted to harmless elemental Nitrogen and water. This happens when the NOx molecules react inside the catalyst with the heat generated by the engine and the ammonia in the DEF/AdBlue® solution.

During cold engine operation at low engine coolant and ambient air temperatures, water vapor will be visible from the exhaust when the engine operates. This water vapor will resemble steam or light white smoke and will dissipate as the engine and machine components warm and is considered normal.

NOTE: After engine shutdown, the SCR system will perform a purge cycle, which permits the supply module to continue to run for up to 70 seconds. This is to be considered normal and requires no action from the operator.

What is Diesel Exhaust Fluid (DEF)/AdBlue®?

DEF/AdBlue® is a non-toxic aqueous urea solution (32.5 %) with a slight ammonia odor used to chemically reduce NOx emissions from heavy-duty diesel powered vehicles.

DEF/AdBlue® is neither explosive nor harmful to the environment and is classified under the minimum-risk category of transportable fluids. DEF/AdBlue® quality is defined by ISO 22241-1. The

American Petroleum Institute (API®) has a voluntary certification program for DEF/AdBlue®. To ensure DEF/ AdBlue® satisfies the requirements of ISO 22241. DEF/AdBlue®. API Diesel Exhaust Fluid Certification Mark is a registered trademark of API in the United States and or other countries.

Storage, handling, and transport

NOTICE: Storage temperatures above 30 °C (86 °F) greatly reduce the shelf life of DEF/AdBlue®.

DEF/AdBlue® has a typical shelf life of 6-12 months. Refer to the **SHELF LIFE** table below. In order for DEF/AdBlue® to remain in a usable condition, storage requirements need to be met.

- Store between -11 °C (12 °F) and 30 °C (86 °F).
- Use only an approved DEF/AdBlue® container.

- Keep container tightly closed.
- Keep container in a cool, well-ventilated area.
- Keep away from heat and direct sunlight.

Thawing

- The machine is equipped with an internal tank heater to thaw frozen DEF/AdBlue®. The machine will still function until the DEF/AdBlue® begins to flow. The SCR system will then function normally.
- Do not heat DEF/AdBlue® for long periods of time at temperatures above 30 °C (86 °F). This causes the solution to decompose, which very slowly decreases the expected shelf life.

NOTICE: Do not use an anti-gelling or freeze point improver in your DEF/AdBlue®. The 32.5 % solution is specifically designed to provide the optimum NOx reduction properties. Any further blending or adjusting of the DEF/AdBlue® mixture will lessen its ability to perform correctly and may cause damage to the SCR components.

Handling and supply of additives, if any.

- Personal Protective Equipment (PPE) is not required under normal conditions. If splashing is likely, wear eye protection. For prolonged or repeated contact, impervious gloves are recommended. Follow the precautions listed in the SAFETY INFORMATION chapter when handling any service fluid.

- No additives are required.

NOTICE: Contaminated DEF/AdBlue® can affect the performance of your machine. Follow all instructions in this manual when handling DEF/AdBlue®.

Shelf life

Constant ambient storage temperature and minimum shelf life

- Less than or equal to 10 °C (50 °F) 36 months
- Less than or equal to 25 °C (77 °F) ¹ 18 months
- Less than or equal to 30 °C (86 °F) 12 months
- Less than or equal to 35 °C (95 °F) 6 months
- Greater than 35 °C (95 °F) ⁻²

¹ To prevent decomposition of DEF/AdBlue®, prolonged transportation or storage above 25 °C (77 °F) should

be avoided.

² Significant loss of shelf life: check every batch before use. See your [Brand] dealer for more information on testing.

NOTE: The main factors taken into account to define the shelf life in the previous figures are the ambient storage temperature and the initial alkalinity of DEF/AdBlue®. The difference in evaporation between vented and non-vented storage containers is an additional factor.

NOTE: The information in this table is for reference only and has been provided by the International Organization for Standardization, Document number ISO 22241-3 Diesel engines - NOx reduction agent AUS 32 - Part 3: Handling, transportation and storage.

Disposal

- Dispose of DEF/AdBlue® and any filter accumulations in accordance with all applicable Federal, State, and local laws governing waste disposal.

For machines sold in California CNH must warrant the diesel emission control system in the application for which it is sold or leased to be free from defects in design, materials, workmanship, or operation of the diesel emission control system which cause the diesel emission control system to fail to conform to the emission control performance level it was verified to, or to the requirements in the California Code of Regulations, Title 13, Sections 2700 to 2706, and 2710, for the periods of time listed below, provided there has been no abuse, neglect, or improper maintenance of your diesel emission control system, vehicle or equipment, as specified in the owner's manuals. Where a warrantable condition exists, this warranty also covers the engine from damage caused by the diesel emission control system, subject to the same exclusions for abuse, neglect or improper maintenance of your vehicle or equipment. Please review your owner's manual for other warranty information. The diesel emission control system may include a core part (e.g., particulate filter, diesel oxidation catalyst, selective catalytic reduction converter) as well as hoses, connectors, and other emission-related assemblies.

Glossary Acronym Definition

DEF	Diesel Exhaust Fluid
ISO	International Organization for Standardization
MSDS	Material Safety Data Sheet
NOx	Nitrogen Oxide
PPE	Personal Protective Equipment
SCR	Selective Catalytic Reduction
ULSD	Ultra Low Sulfur Diesel

SELECTIVE CATALYTIC REDUCTION (SCR) - BASIC INSTRUCTIONS

Requirements

The operator must maintain appropriate DEF/AdBlue® levels at all times. The SCR system is compatible with up to 7% bio-diesel fuel.

Diesel Exhaust Fluid (DEF)/AdBlue® refilling

The DEF/AdBlue® tank cap (1) can be identified by the “blue” color of the cap. A fitting under the cap prevents the insertion of a diesel fill nozzle.

NOTE: *If any DEF/AdBlue® spills or contacts any surface other than the storage tanks, immediately clean the affected surface with clear water. DEF/AdBlue® will cause corrosion on painted and unpainted metallic surfaces, and may distort some plastic and rubber components.*

It is recommended that DEF/AdBlue® filling equipment should be used having a fill nozzle/pump with the correct length and diameter, triggered by the magnet in the tank filler neck and with overflow flow cut out.

This will ensure that:

- The screen in the filler neck will not be damaged.
- Impurities are not entering the DEF/AdBlue® tank. The standardized DEF/AdBlue® nozzle matches the filler neck diameter.
- The DEF/AdBlue® tank is not overfilled, as the DEF/AdBlue® pump will stop when the DEF/AdBlue® tank is full.
- DEF/AdBlue® is not pumped in the fuel tank, as the DEF/AdBlue® nozzle cannot pump when the magnet is not sensed.

NOTICE: *Refilling with a funnel is not recommended as this may lead to damage of the screen in the filler neck.*

NOTE: *The information above has been provided by the International Organization for Standardization (ISO), Document number ISO 22241-4 Diesel engines - NOx reduction agent AUS 32 - Part 4: Refilling interface.*

Diesel Exhaust Fluid (DEF)/AdBlue® consumption

NOTE: *DEF/AdBlue® consumption is highly dependent on engine loads, humidity levels, DEF/AdBlue® fluid concentration, and engine speed. The “typical” consumption is only a guideline to verify proper function of the SCR system. CNH recommends to fill the DEF/AdBlue® tanks at every fuel refilling interval.*

MAINTENANCE SCHEDULE

SERVICE INTERVAL	ITEM NUMBER	SERVICE POINTS	Initial Service	FREQUENCY IN HOURS							
				CHECK	CLEAN	CHANGE	DRAIN	LUBRICATE	REPLACE	ADJUST	
Variable Periodic (*)	2	Radiator Coolant Level		*							
	13	Tires		*							
	16	Hydraulic Filter		*							
	12	Alternator, AC, Drive Belt		*							
	31	Air cleaner		*	*						
	19	Bleed Fuel Filter of Condensation					*				
	28	Clean SCR system DEF tank filter			*						
	XX	Fire extinguisher		*							
Every 10 Hours	1	Check Engine Oil Level		10							
Every 50 Hours	13	Check Engine Coolant Level		50							
	3	Check Transmission Oil Level		50							
	4	Check Hydraulic Oil Level		50							
	5 & 6	Grease Bucket Mounting Fittings						50			
	7	Grease machine and attachments						50			
First 100 Hours	16	Change Engine Oil and Filters	100								
	18	Replace Fuel Filters	100								
	20	Change Hydraulic Filter	100								
	25	Change Oil in Axles	100								
	13	Check wheel torque		100							
	28	Clean in-line DEF supply filter			100						
Every 100 Hours	8	Lubricate The Steering Cylinder Pivots - Rod And Closed End (4 Fittings)						100			
	9	Grease Front Drive Shaft Support Bearing						100			
	10	Lubricate Loader Lift & Cylinder Pivots (10) Z-bar						100			
	10	Lubricate Loader Lift & Cylinder Pivots (18) XT						100			
Every 250 Hours	11	Check Cab Air Filter		250							
	14	Check Tire Pressure & Wheel Torque	4	250							
	12	Check Drive Belt		250							
	XX	Trans Clutch Calibration (See Section 6002)	250	1000							
Every 500 Hours	14	Check Axle Oil Level		500							
	15	Check Battery Electrolyte Level		500							
	16	Change Engine Oil and Filter				500					
	XX	Check ROPS		500							
	18	Drain Fuel Tank Condensation & Water Separator					500				
	19	Replace Fuel Filter							500		

Every 1000 Hours	20	Replace Hydraulic Oil filter						1000	
	21	Grease Articulation Fittings					1000		
	24	Change crankcase filter				1000		1000	
	23	Replace Drive Belt							
	11	Replace Cab Air Filter						1000	
	26	Change Transmission Oil and Filter				1000			
	XX	Check Injector Calibration		1000					
	XX	Check Valve Adjustment (Engine Manual)		1000					
	XX	Trans Clutch Calibration (See Section 6002)		1000					
Every 1500 Hours	21	Change Front & Rear Axle Oil				1500			
	26	Change Transmission Oil and Filter				1500			
	28	Clean in-line DEF filter							
Every 2000 Hours	29	Change Hydraulic Oil				2000			
	30	Change Coolant				2000			
	31	Replace Engine Air Cleaner						2000	
	32	Lubricate cab and door					2000		
	XX	Valve Clearance (Engine Manual)							2000
Every 3000 Hours	XX	Replace DEF supply module filter						3000	
Every 6000 Hours	XX	Engine Injectors (Engine Manual)			6000				
	XX	Fuel Pump (Engine Manual)			6000				6000

MAINTENANCE POINTS

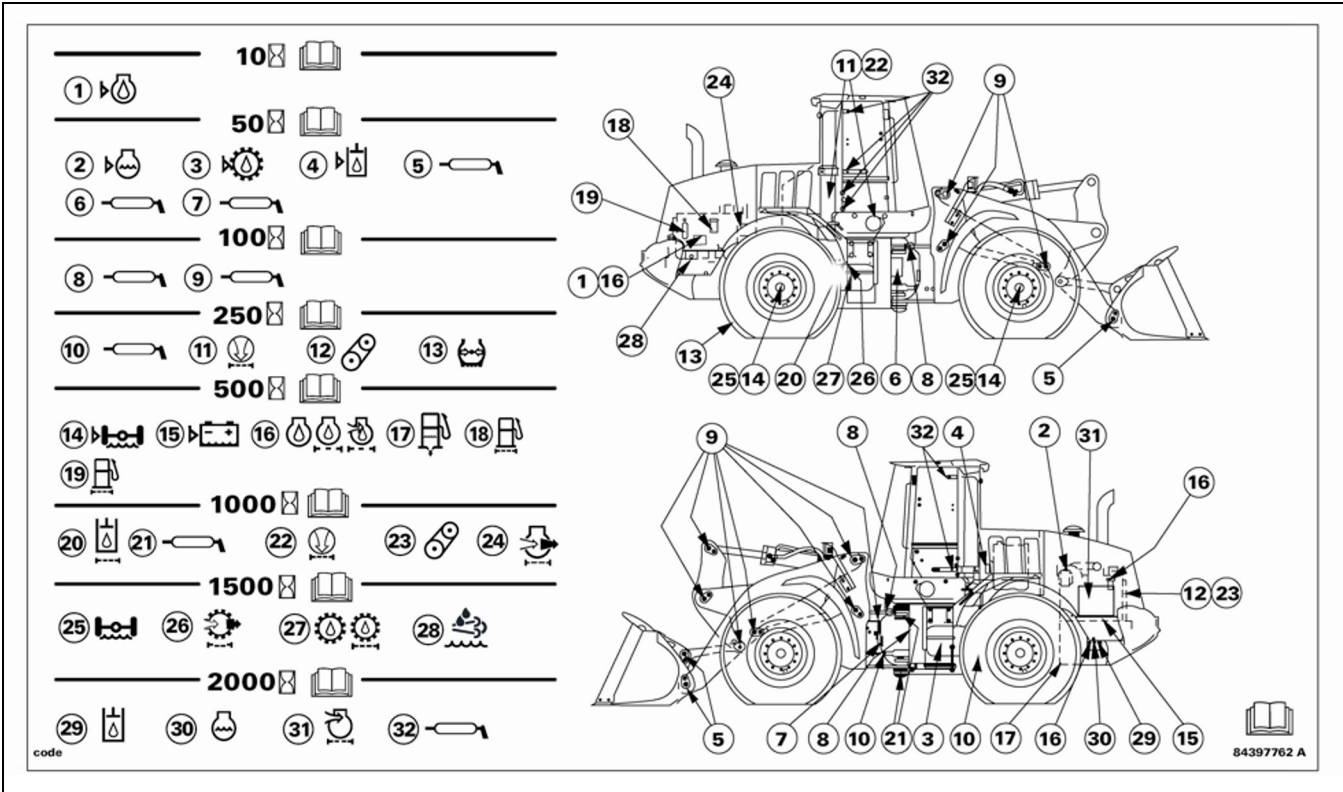

See your Operators manual for maintenance of safety related items and for detailed information of the service items on this chart. Operators and service manuals are available for this machine from your dealer.

If you operate the machine in severe conditions, lubricate and service the machine more frequently.

Section 1003

METRIC CONVERSION CHART

1003

TABLE OF CONTENTS

CONVERSION FACTORS	3
Metric to U.S.	3
U.S. to Metric	4

CONVERSION FACTORS

Metric to U.S.

	<u>MULTIPLY</u>	<u>BY</u>	<u>TO OBTAIN</u>
Area:	sq. meter hectare	10.763 91 2.471 05	square foot acre
Force:	newton newton	3.596 942 0.224 809	ounce force pound force
Length:	millimeter meter kilometer	0.039 370 3.280 840 0.621 371	inch foot mile
Mass:	kilogram	2.204 622	pound
Mass/Area:	kilogram/hectare	0.000 466	ton/acre
Mass/Energy:	gr/kW/hr.	0.001 644	lbs/hp/hr.
Mass/Volume:	kg/cubic meter	1.685 555	lb/cubic yd.
Power:	kilowatt	1.341 02	horsepower
Pressure:	kilopascal bar	0.145 038 14.50385	lb/sq. inch lb/sq. inch
Temperature:	degree C	1.8 x C +32	degree F
Torque:	newton meter newton meter	8.850 748 0.737 562	lb/inch lb/foot
Velocity:	kilometer/hr.	0.621 371	miles/hr.
Volume:	cubic centimeter cubic meter cubic meter milliliter litre litre litre litre	0.061 024 35.314 66 1.307 950 0.033 814 1.056 814 0.879 877 0.264 172 0.219 969	cubic inch cubic foot cubic yd. ounce (US fluid) quart (US liquid) quart (Imperial) gallon (US liquid) gallon (Imperial)
Volume/Time:	litre/min. litre/min.	0.264 172 0.219 969	gallon/min. (US liquid) gallon/min. (Imperial)

U.S. to Metric

	<u>MULTIPLY</u>	<u>BY</u>	<u>TO OBTAIN</u>
Area:	square foot acre	0.092 903 0.404 686	square meter hectare
Force:	ounce force pound force	0.278 014 4.448 222	newton newton
Length:	inch foot mile	25.4 * 0.304 8 * 1.609 344 *	millimeter meter kilometer
Mass:	pound ounce	0.453 592 28.35	kilogram gram
Mass/Area:	ton/acre	2241 702	kilogram/hectare
Mass/Energy:	lb/hp/hr	608.277 4	gr/kW/hr
Mass/Volume:	lb/cubic yd.	0.593 276	kg/cubic meter
Power:	horsepower	0.745 700	kilowatt
Pressure:	lbs/sq. in. lbs/sq. in. lbs/sq. in.	6.894 757 0.069 0.070 303	kilopascal bar kg/sq. cm
Temperature:	degree F	1.8 F - 32	degree C
Torque:	pound/inch pound/foot	0.112 985 1.355 818	newton meter newton meter
Velocity:	miles/hr.	1.609 344 *	kilometer/hr.
Volume:	cubic inch cubic foot cubic yard ounce (US fluid) quart (US liquid) quart (Imperial) gallon (US) gallons (Imperial)	16.387 06 0.028 317 0.764.555 29.573 53 0.946 353 1.136 523 3.785 412 4.546 092	cubic centimeter cubic meter cubic meter milliliter litre litre litre litre
Volume/Time:	gallon/min.	3.785 412	litre/min.

* = exact

Section 2000

ENGINE AND RADIATOR REMOVAL AND INSTALLATION

TABLE OF CONTENTS

Engine	3
Removal	3
Installation	10
Radiator	18
Removal	18
Installation	20

ENGINE

Removal

STEP 1

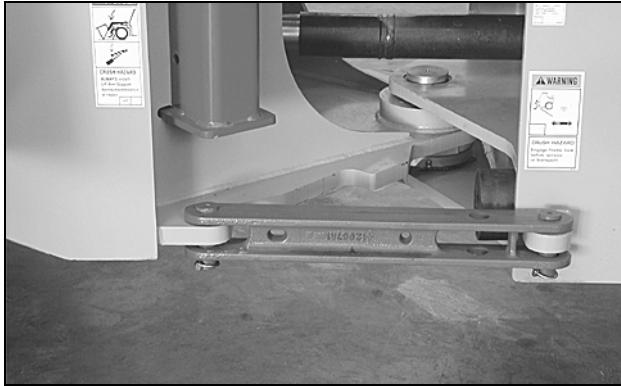

BD03A040

Park machine on a level surface and lower bucket to ground. Put articulation lock in LOCKED position.

STEP 2

Stop engine. Actuate brake pedal several times to discharge brake accumulators. Put key switch in ON position and move loader control lever back and forth at least 30 times to release any pressure from hydraulic circuit. Put key switch in OFF position.

STEP 3

Slowly loosen the filler cap for hydraulic reservoir to release air pressure in hydraulic reservoir.

STEP 4

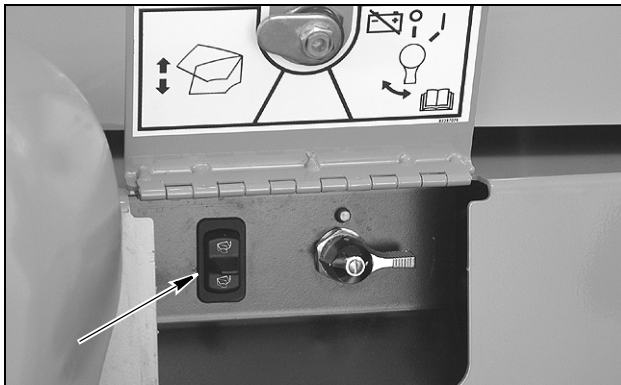

BD06F108

The master and hood raise switch are located by the battery box. Raise the hood with the hood lift motor. Put master disconnect switch in OFF position. Remove both battery covers and disconnect batteries from the machine.

STEP 5



BD02N160

Put a 30 liter (32 U.S. quart) container below radiator drain. Remove radiator cap. Remove cap and drain coolant into container. Install cap after coolant has drained. Install radiator cap.

STEP 6

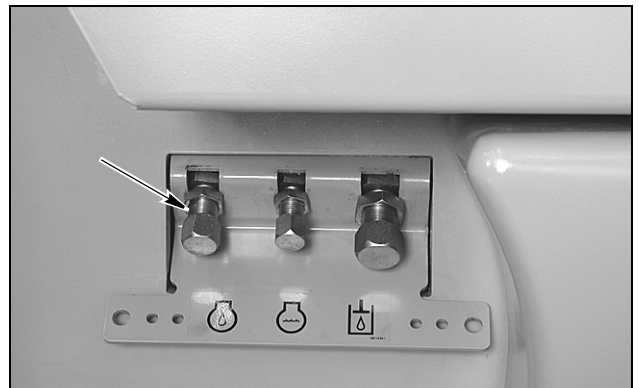

BD02N160

Put a 15.1 liter (16 U.S. quart) container below engine oil drain. Remove cap and drain oil into container. Install cap after oil has drained.

NOTE: After draining oil disconnect drain hose from frame for removal with engine.

STEP 7

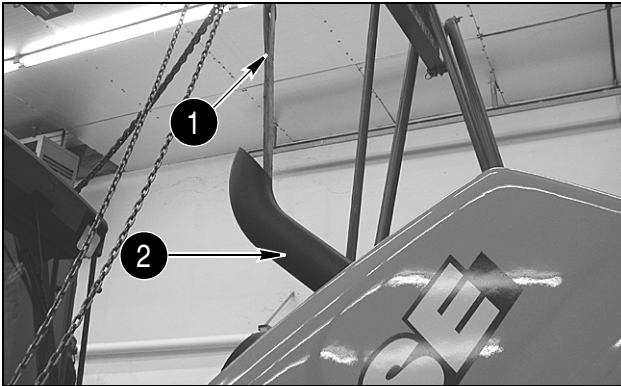

BD03A231

Double up a nylon lifting strap (1) and slide through the exhaust stack (2) on the hood.

STEP 8

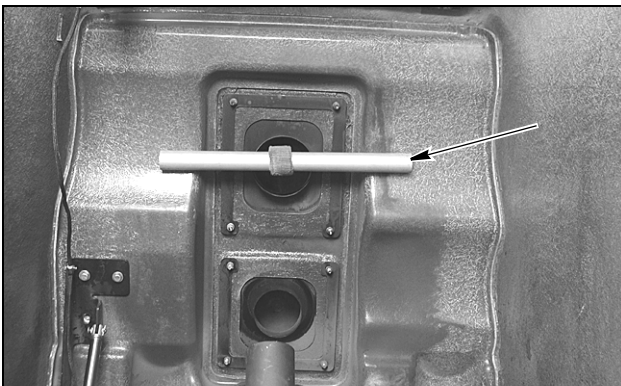

BD03A230

Place a solid steel bar through the strap, raise the hood and release tension on the lifting motor.

STEP 9

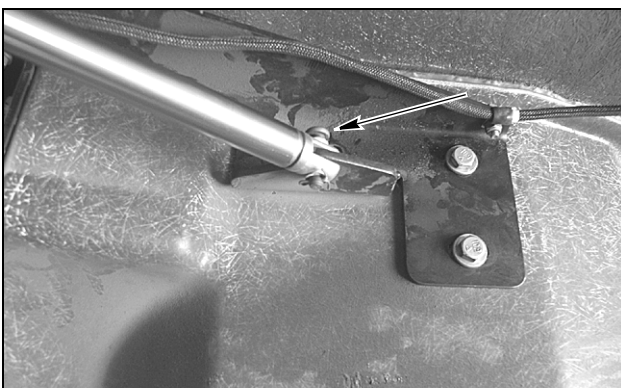

BD03A228

Remove the pin from the top of the lifting motor.

STEP 10



BD06F109

Tag and disconnect hood wiring harness connector from rear chassis wiring harness connector.

STEP 11

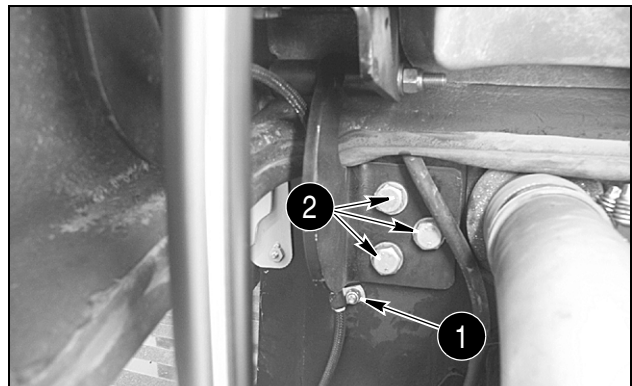

BD03A227

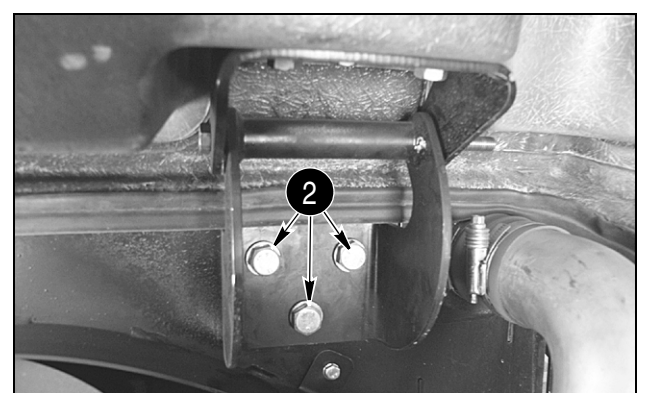

BD03A226

Remove mount bolt (1) and backup alarm wiring harness clamp from cooler housing. Have another person balance the hood and remove the hood hinge mounting bolts (2) from the cooler frame.

STEP 12



BD03A232

Carefully raise and remove hood from loader. Lower hood onto suitable platform and disconnect lifting equipment.

STEP 13

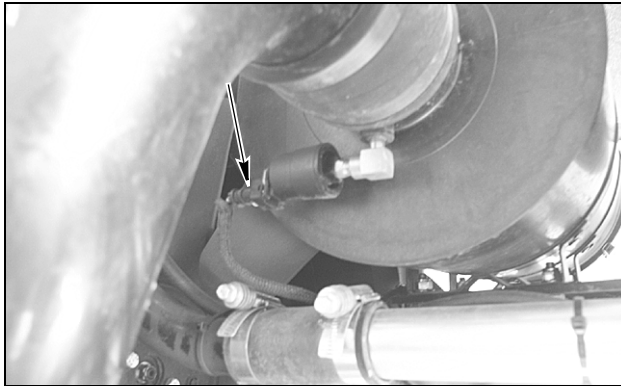

BD03A224

Tag and disconnect engine wiring harness connector from air filter restriction switch.

STEP 14

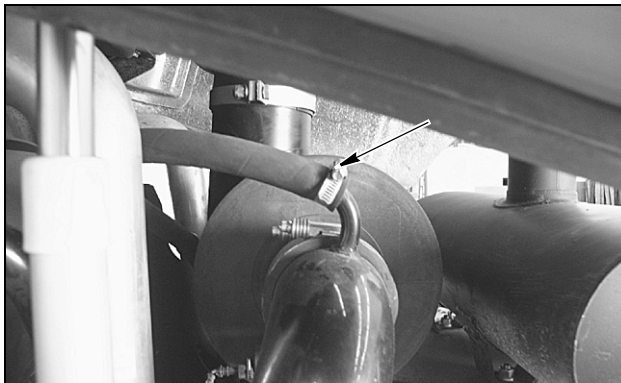

BD03A225

Loosen clamp on air cleaner intake hose and remove the crankcase ventilation hose.

STEP 15

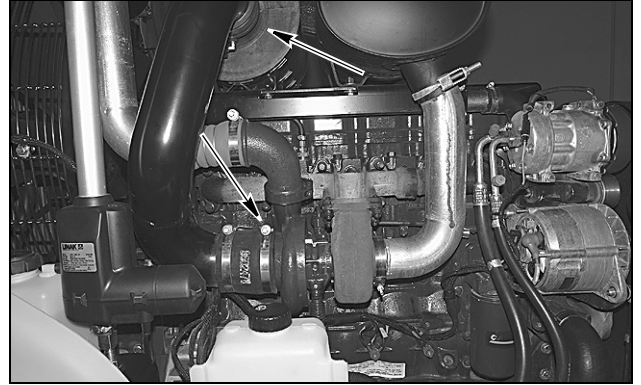

BD06F110

Loosen clamps on turbocharger and air cleaner, remove the intake hose.

STEP 16

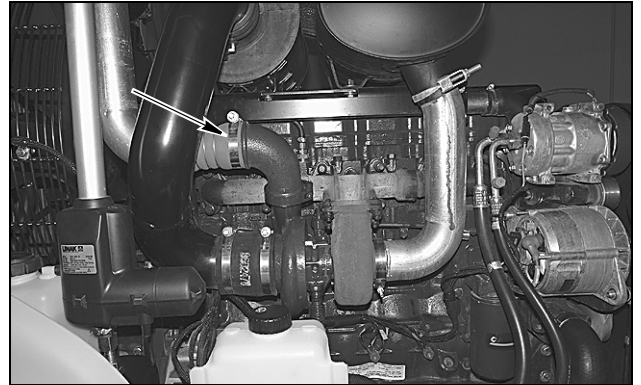

BD06F110

Loosen the clamp on the turbocharger for the after cooler inlet hose.

STEP 17



BD03A115

Loosen the clamp on the after cooler and remove the after cooler inlet hose from the machine.

STEP 18

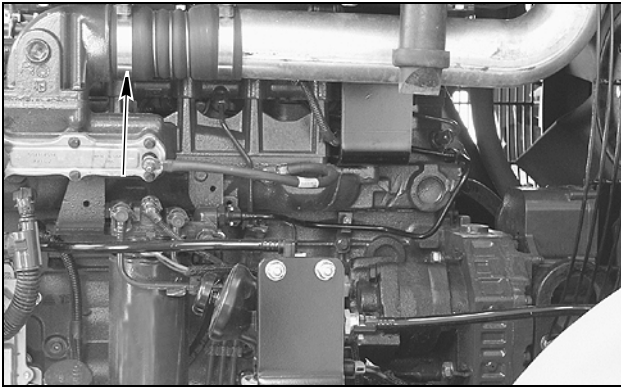

BD06F111

Loosen the clamp on the intake manifold for the after cooler output hose.

STEP 19



BD03A118

Loosen the clamp on the after cooler and remove the after cooler outlet hose from the machine.

STEP 20

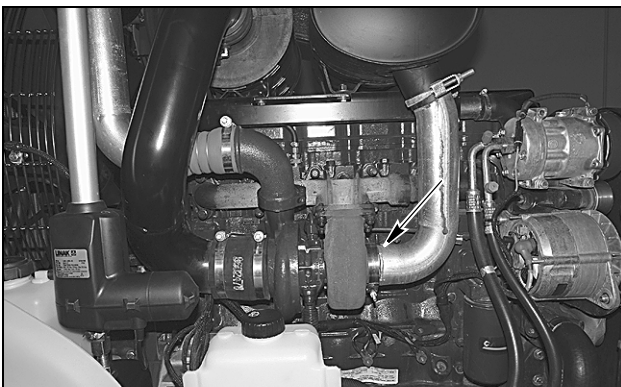

BD06F110

Loosen the exhaust clamp from the turbocharger.

STEP 21

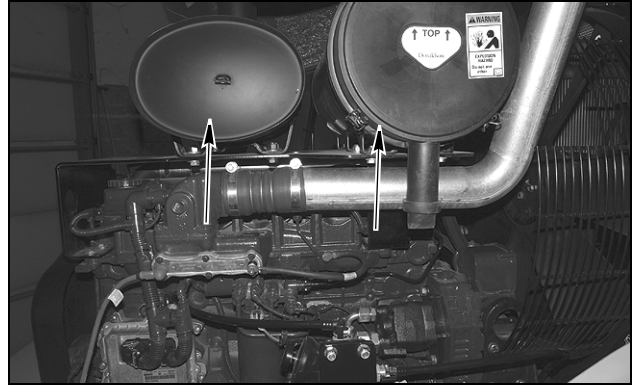

BD06F112

Remove the air cleaner and muffler from the bracket.

STEP 22

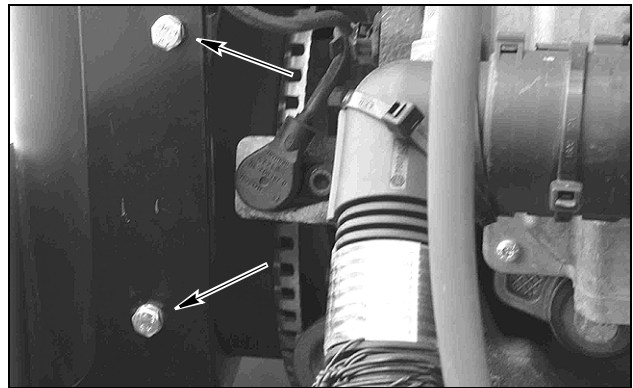

BD06F113

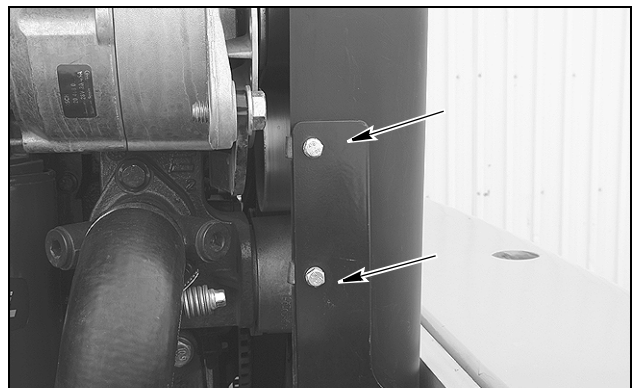

BD06F114

Remove the four mounting bolts from the belt cover, remove the cover.

NOTE: After removing the belt cover remove the cover mounting brackets from the machine frame.

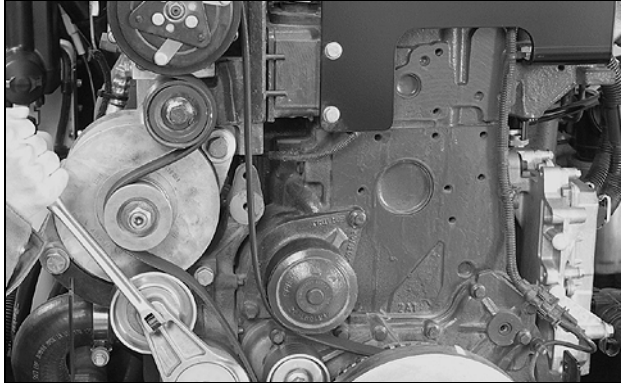
STEP 23

BD06F115

Remove the drive belt from the engine.

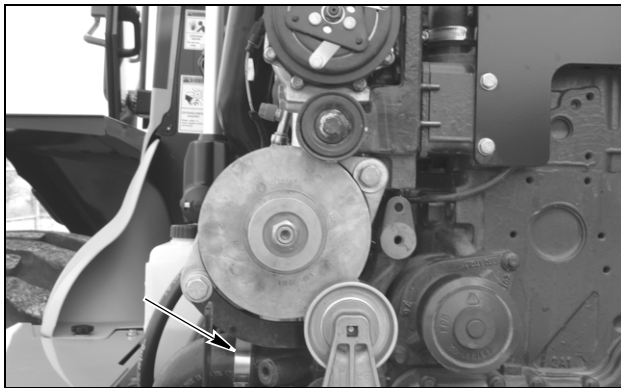
STEP 24

BD06F116

Loosen clamps and remove lower cooler hose from the engine.

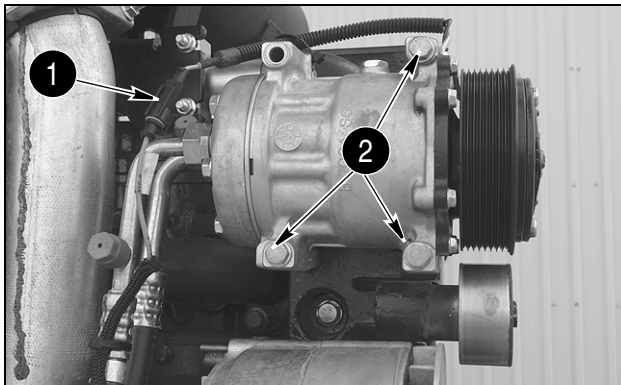
STEP 25

BD06F117

If loader is equipped with air conditioning, identify, tag, and disconnect the engine wiring harness connectors from air compressor clutch connector (1). Remove the three mounting bolts (2) for the compressor and set the compressor on the left battery cover.

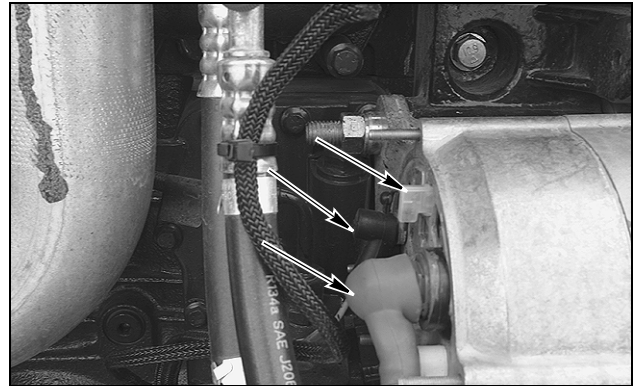
STEP 26

BD06F118

Tag and disconnect the wiring from the alternator.

STEP 27

BD06F119

Remove bolt securing wiring harness clamp to engine.

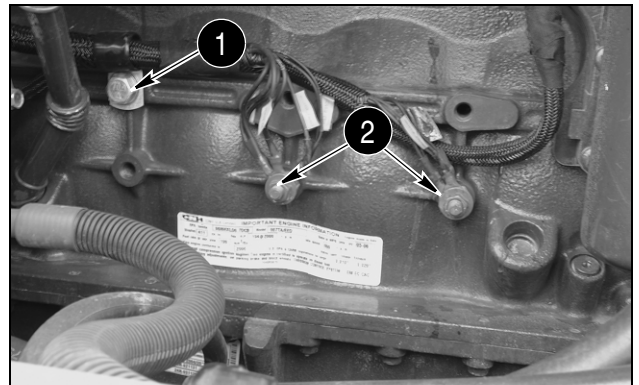
STEP 28

BD06F120

Remove bolt securing wiring harness clamp (1) to the engine. Remove ground wires (2) from the engine.

STEP 29

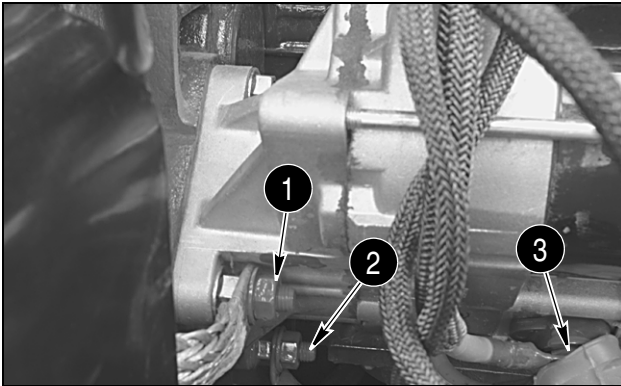

BD06F121

Tag and remove the wires from the starter solenoid (3), remove the ground cable (2), and ground strap (1) from the starter.

NOTE: Move the starter cables away from the engine, move the wiring harness away from the engine.

STEP 30

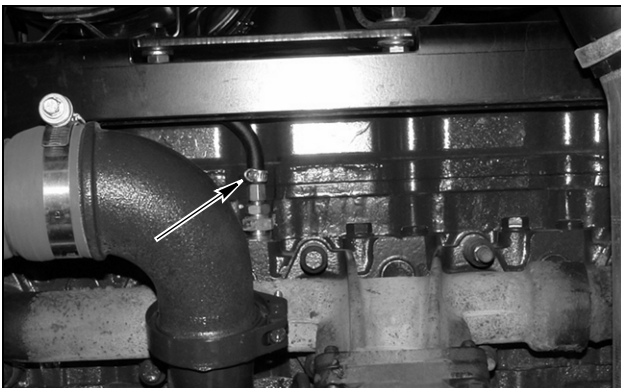

BD06F146

Disconnect the engine coolant vent hose and route to the rear of the engine.

STEP 31

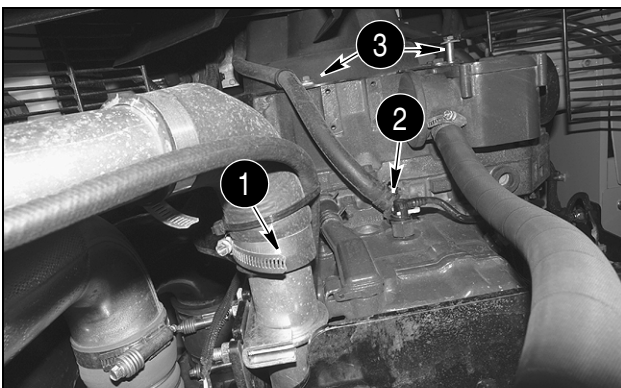

BD06F122

Remove the radiator hose (1) from the rear of the engine, remove the heater hose from the rear of the engine (2), remove the clamp bolts and clamps (3) from the bell housing.

STEP 32

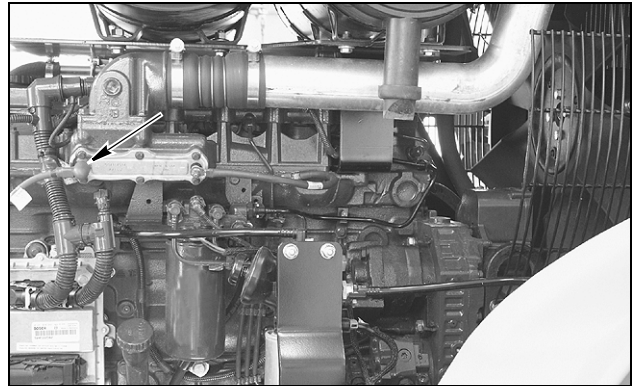

BD06F111

Tag and remove the grid heater cable.

STEP 33

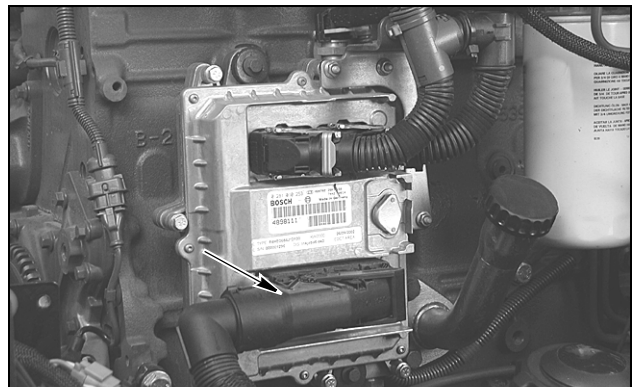

BD03A142

Disconnect the wiring harness from the EDC 7 controller.

NOTE: Lifting up on the lever will release the connector from the controller.

STEP 34

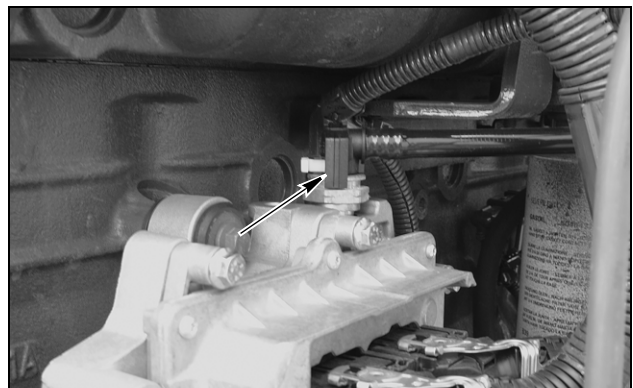

BD06F123

Remove the fuel line from the top of the EDC 7 controller, plug the line and cap the fitting.

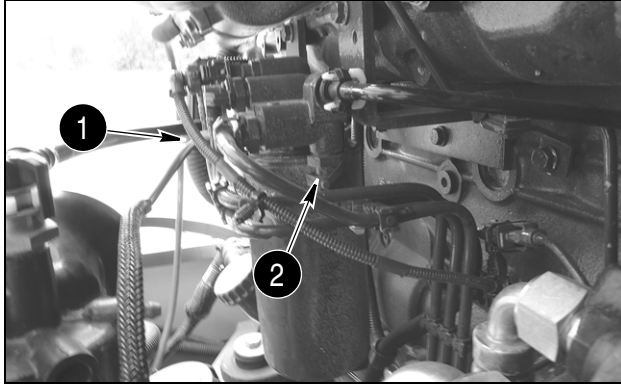
STEP 35

BD06F124

Tag and disconnect the fuel filter heater wires (1), disconnect the fuel line (2) from the fuel filter head, plug the line and cap the fitting.

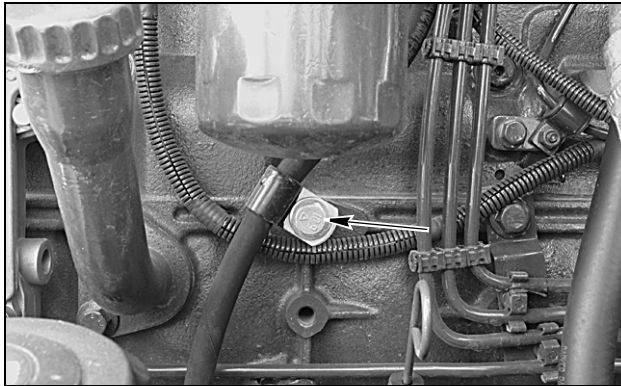
STEP 36

BD06F125

Remove bolt and clamp.

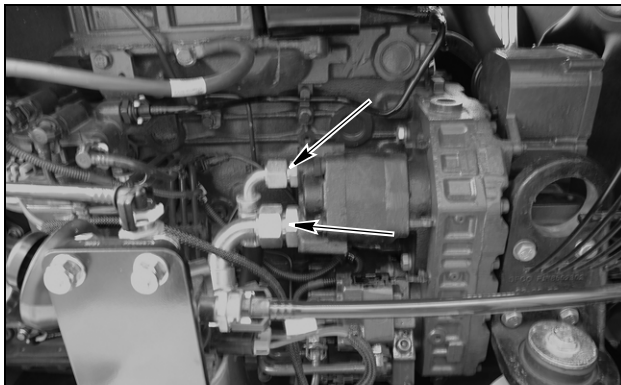
STEP 37

BD06F126

Connect and turn on vacuum pump to hydraulic reservoir. Tag and remove the hydraulic lines from the brake system pump, plug the lines and cap the fittings.

STEP 38

BD06F127

Remove the lower cover for the drive shaft.

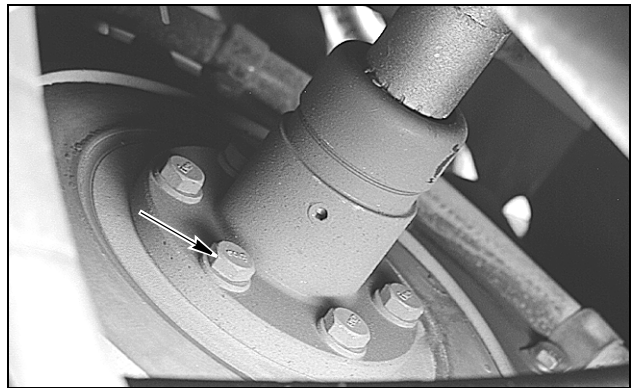
STEP 39

BD03A172

Remove the drive shaft bolts from the flywheel. Move the drive shaft clear of the flywheel.

STEP 40

Connect suitable lifting equipment to engine lifting brackets. Take up all slack in lifting equipment. Remove the engine mounting bolts and lift the engine enough to gain access to the drain hose, pull the drain hose with the engine.

STEP 41

Slowly raise engine from rear chassis. Be sure all harness connections and hoses have been disconnected and are clear of the engine. Remove engine from machine.

Installation

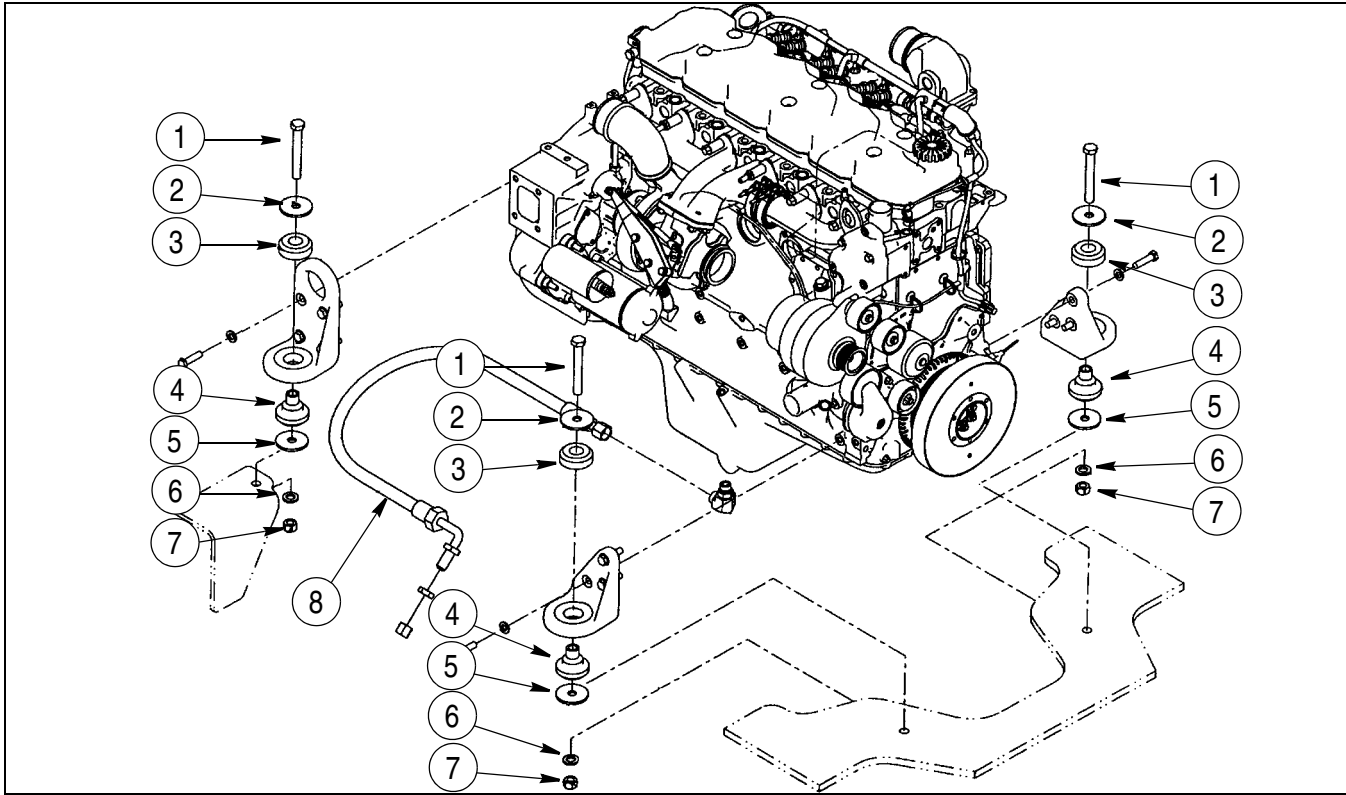

BS03B035

1. ENGINE MOUNT BOLT
2. WASHER

3. INSOLATOR UPPER
4. INSOLATOR LOWER

5. WASHER
6. WASHER

7. NUT
8. REMOTE OIL DRAIN HOSE

STEP 42

If engine rubber isolators require replacement, remove and discard isolators (3 and 4). Install new rubber isolator (4), then rubber isolator (3).

STEP 43

Slowly raise engine and move into position over rear chassis. Be sure all harness connections and hoses are out of the way then lower engine. Put washer (5) between front rubber isolator (4) and chassis. Install washer (2), bolt (1), washer (6), and nut (7) in engine isolators. Lower engine into position.

STEP 44

Tighten engine mounting bolts to a torque of 244 to 298 Nm (180 to 220 lb-ft).

STEP 45

Disconnect lifting equipment from engine lifting brackets.

STEP 46

Connect engine oil drain hose to frame bracket.

STEP 47

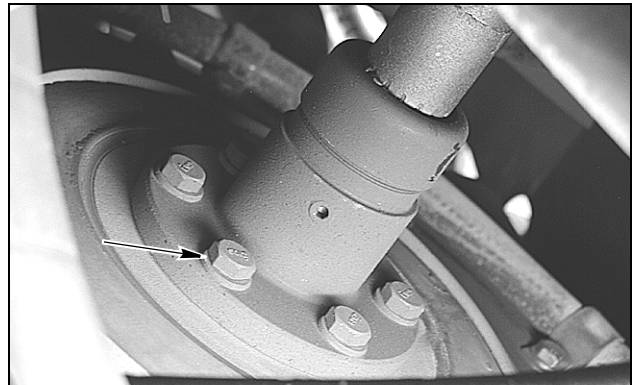

BD03A172

At front of engine, position drive shaft on engine coupling. Install six bolts to secure drive shaft to engine coupling. Tighten the six bolts to a torque of 53 to 62 Nm (39 to 46 lb-ft).

STEP 48



Install the lower cover for the drive shaft.

STEP 49

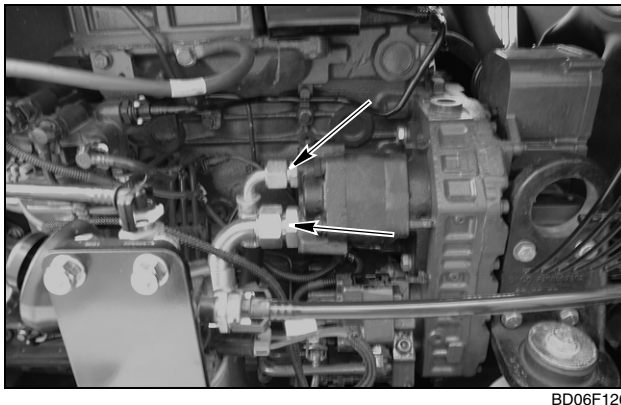

Connect and turn on vacuum pump to the hydraulic reservoir. Remove caps from fittings and plugs from hoses. Connect hoses to brake pump following tags installed during removal. Remove and discard tags. Turn off and disconnect vacuum pump from hydraulic reservoir.

STEP 50

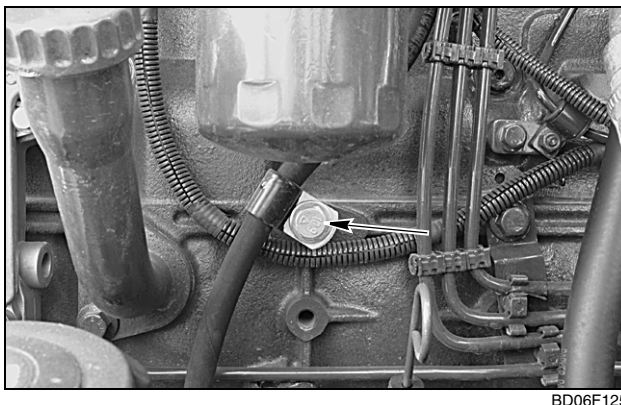

Install bolt and clamp for fuel return hose.

STEP 51

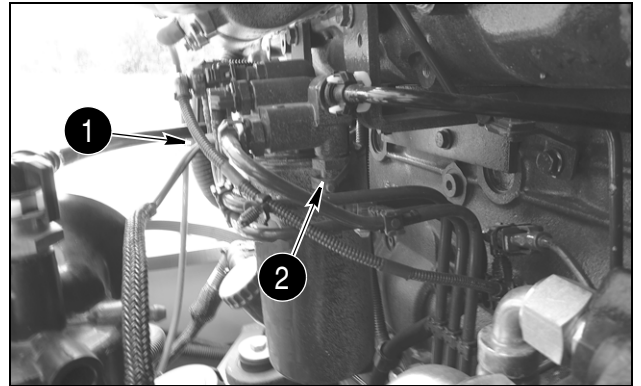

Remove cap from fitting and plug from the hose, connect fuel line (2). Connect fuel filter heater wires (1). Remove and discard tag.

STEP 52

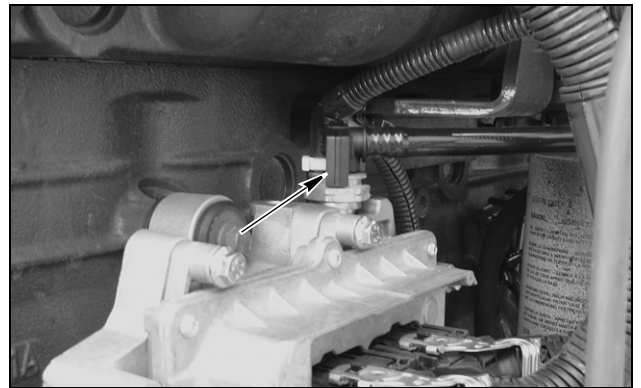

Remove cap from fitting and plug from the hose, connect fuel line to EDC 7.

STEP 53

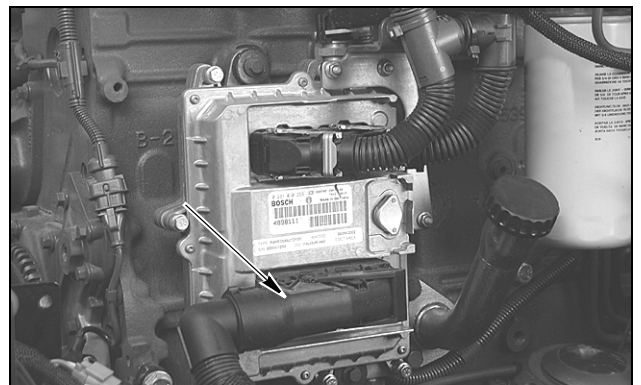

Connect wiring harness to EDC 7 controller.

NOTE: Start the connector on the EDC 7 with lever straight out from EDC 7. Use lever to pull connector into position.

STEP 54

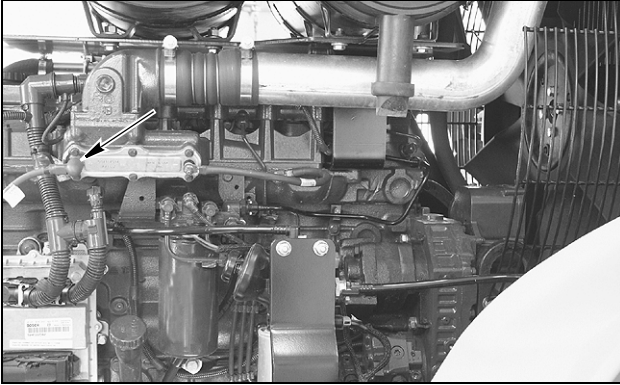

BD06F111

Connect grid heater cable to grid heater. Remove and discard tag.

STEP 55

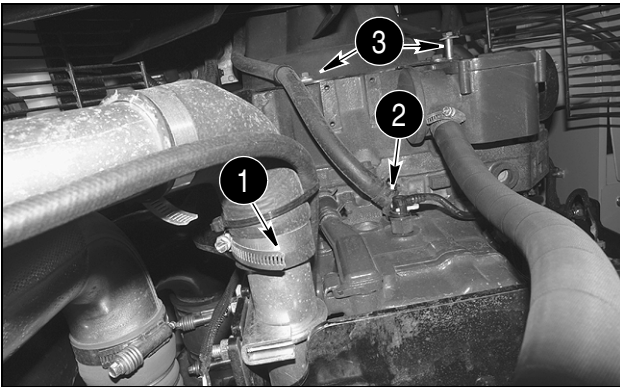

BD06F122

Install the heater hose (2) to the rear of the engine, mount the clamps (3), install the radiator hose (1).

STEP 56

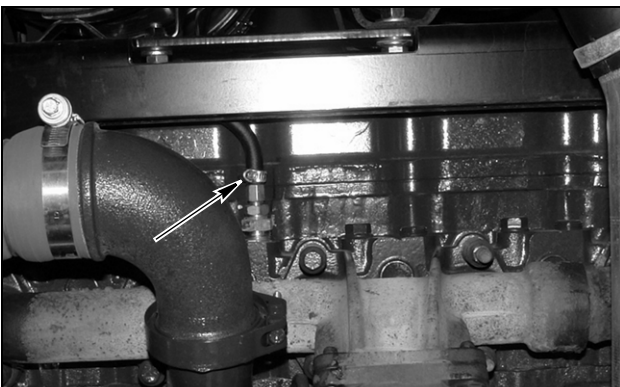

BD06F146

Connect the engine coolant vent hose.

STEP 57

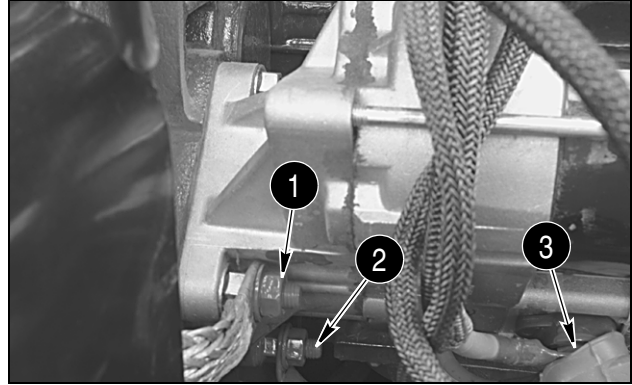

BD06F121

Install the wires to the starter solenoid (3), install the ground cable (2), and ground strap (1) to the starter. Remove and discard tags.

STEP 58

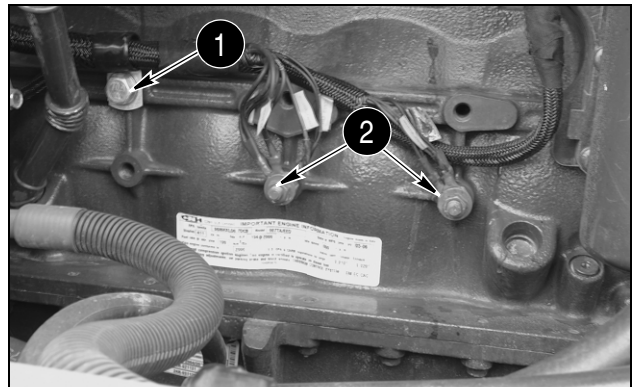

BD06F120

Install bolt securing wiring harness (1) clamp to the engine. Install ground wires (2) to the engine.

STEP 59

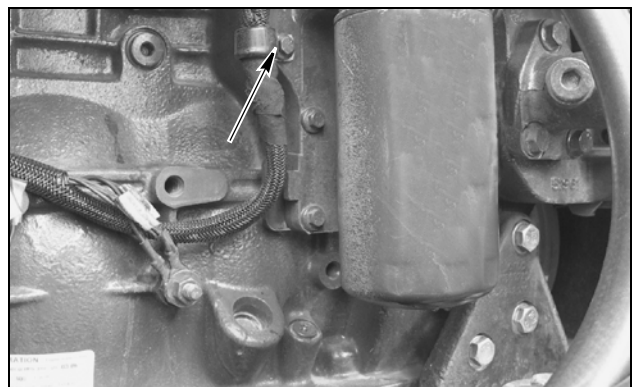

BD06F119

Install bolt securing wiring harness clamp to engine.

STEP 60

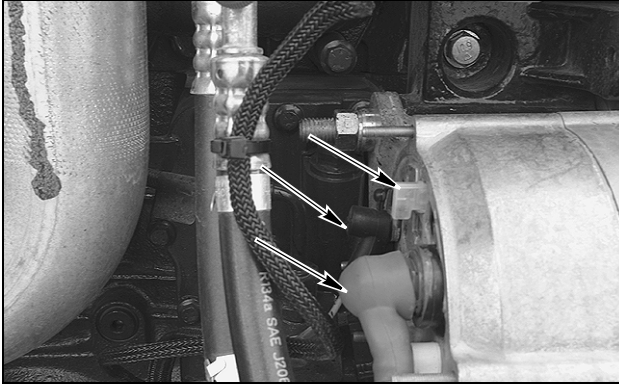

BD06F118

Connect the wiring to the alternator. Remove and discard tags.

STEP 61

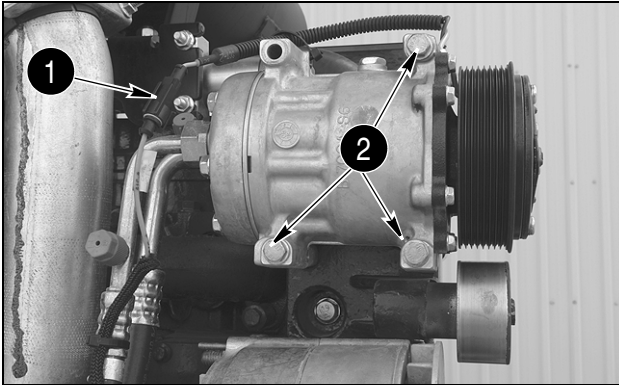

BD06F117

If loader is equipped with air conditioning, mount the compressor using the three mounting bolts (2), connect the engine wiring harness connectors to air compressor clutch connector (1). Remove and discard tags.

STEP 62

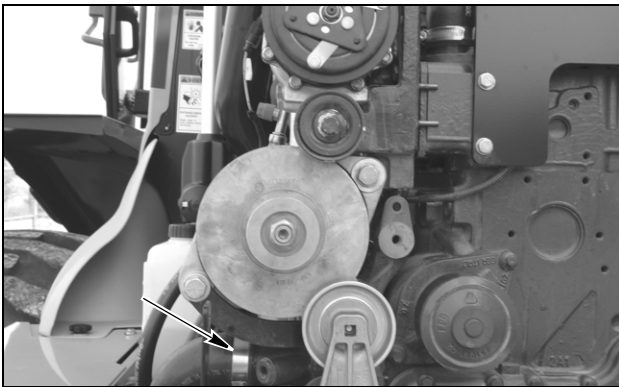

BD06F116

Install lower cooler hose to the engine and tighten the clamps to a torque of 10.1 to 11.3 Nm (90 to 100 lb-inch).

STEP 63

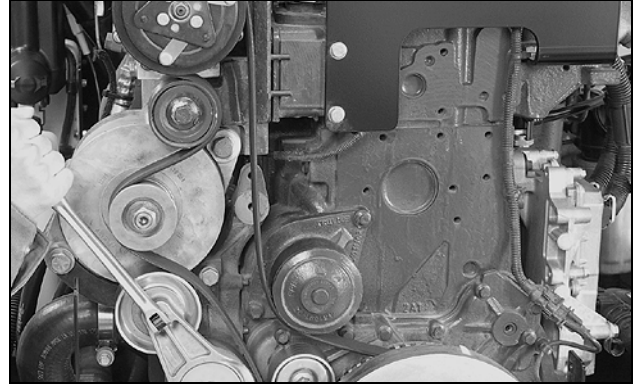

BD06F115

Install the drive belt.

STEP 64

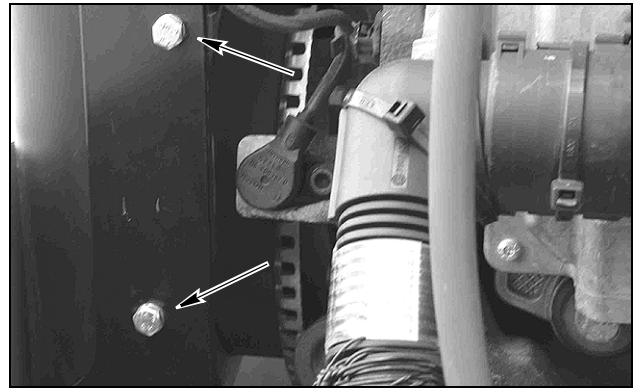

BD06F113

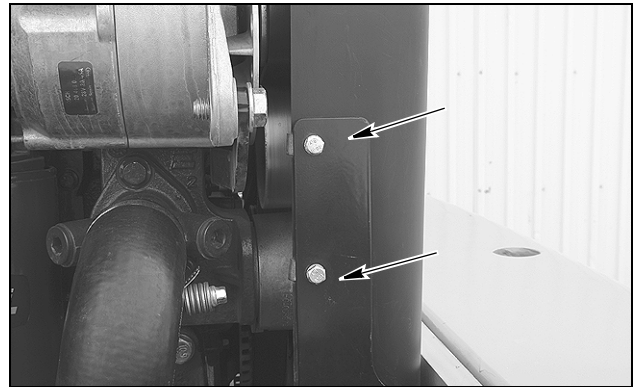

BD06F114

Install the cover mounting brackets to the machine frame. Install the belt cover, install the four mounting bolts for the belt cover.



Suggest:

If the above button click is invalid.

Please download this document

first, and then click the above link

to download the complete manual.

Thank you so much for reading

STEP 65

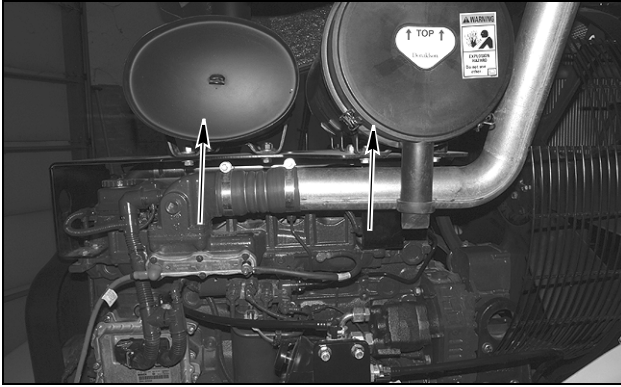

BD06F112

Place the muffler and air cleaner on the bracket. Install mounting bolts in air cleaner and tighten, install the mounting bolts in the muffler and leave loose at this time.

STEP 66



BD06F110

Install and tighten the exhaust clamp on the turbocharger, tighten the muffler mounting bolts.

STEP 67



BD03A118

Place the after cooler outlet hose on the machine. Tighten the clamp on the after cooler.

STEP 68

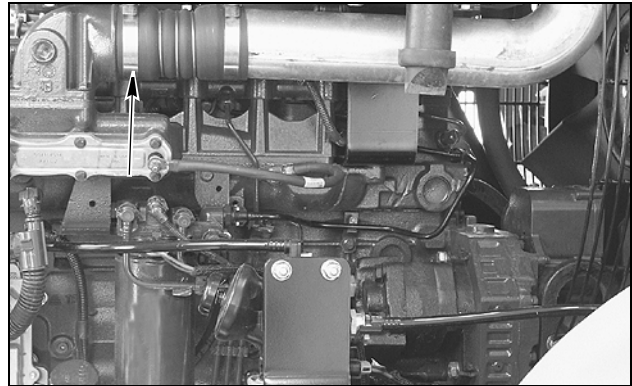

BD06F111

Tighten the clamp on the intake manifold for the after cooler output hose.

STEP 69



BD03A115

Place the after cooler inlet hose on the machine. Tighten the clamp on the after cooler.

STEP 70



BD06F110

Tighten the clamp on the turbocharger for the after cooler inlet hose.

<https://www.ebooklibonline.com>

Hello dear friend!

Thank you very much for reading.

Enter the link into your browser.

The full manual is available for immediate download.

<https://www.ebooklibonline.com>