

Service manual

580SR
580SR+
590SR
695SR
SERIES 3

Print No. 87643852B



580SR
580SR+
590SR
695SR
SERIES 3

Service manual

Print No. 87643852B



TO READER

This manual has been printed for a skilful engineer to supply necessary technical information to carry out service operations on this machine.

Read carefully this manual to collect correct information relevant to repair procedures.

For any question or remark, or in case of any error relevant the contents of this manual, please contact:

CNH ITALIA S.p.A.
Technical Information
Viale delle Nazioni, 55
41100 MODENA - Italy

REFERENCE

Beyond this Service Manual, also refer to documents hereunder listed:

- Operator's Manual
- Parts Catalogue

COMPLETE HANDBOOK FOR INSTRUCTIONS AND REPAIRS

The complete Service Manual consists of two volumes:

- 580SR / 580SR+ / 590SR / 695SR
Service Manual for "Loader backhoe"
- 580SR / 580SR+ / 590SR / 695SR
Service Manual "Engine"

The Service Manuals for "Loader backhoe" and "Engine" contain the necessary technical information to carry out service and repair on machine and on engine, necessary tools to carry out those operations and information on service standard, on procedures for connection, disconnection, disassembly and assembly of parts.

The complete Service Manual which covers the loader backhoe models 580SR / 580SR+ / 590SR / 695SR consists of the following volumes, which can be identified through their print number as stated below:

VOLUME	MACHINE TYPE	PRINT NUMBER
Service Manual - "Loader backhoe"	580SR / 580SR+ / 590SR / 695SR	87643852B
Service Manual - "Engine"	580SR / 580SR+ / 590SR / 695SR	87659057A

LOADER BACKHOE MODELS

The complete range of Loader Backhoe models described in this manual are identified below:

	580SR	580SR+	590SR	695SR
Powershift	/	•	•	•
Powershuttle	•	•	•	/
Stabilizer sideshift	•	•	•	•
Stabilizer center pivot	/	/	/	•
Cab	•	•	•	•
Rops	•	/	/	/
2WD	•	/	/	/
4WD	•	•	•	•
4WS	/	/	/	•
Pilot control	•	•	•	•
Mechanical control	•	•	•	•
Engine 72 kW-97 HP model F4GE948C*601 (mechanical)	•	/	/	/
Engine 72 kW-97 HP model F4HE0484C*J102 (electronic)	/	•	/	/
Engine 82 kW-110 HP model F4HE9484C*J102 (electronic)	/	/	•	/
Engine 82 kW-110 HP model F4HE9484C*J103 - 4WS (electronic)	/	/	/	•
Short dipper	/	/	/	/
Long dipper	•	•	•	•

<https://www.ebooklibonline.com>

Hello dear friend!

Thank you very much for reading.

Enter the link into your browser.

The full manual is available for immediate download.

<https://www.ebooklibonline.com>

SECTION 00 - SAFETY PRECAUTIONS

SECTION 01 - MAINTENANCE

SECTION 02 - TECHNICAL SPECIFICATIONS

1. LOADER BACKHOE MODELS 3

2. IDENTIFICATION OF MAIN COMPONENTS 4

3. SPECIFICATIONS 6

 3.1 DIESEL ENGINE 6

 3.2 TRANSMISSION 8

 3.3 AXLES 9

 3.4 BRAKES 9

 3.5 STEERING 10

 3.6 HYDRAULIC SYSTEM 10

 3.7 FRONT COUNTERWEIGHT 10

 3.8 NOISE AND VIBRATION LEVELS 11

 3.9 BUCKETS 11

 3.10 TYRES 12

4. DIMENSIONS AND PERFORMANCE 13

 4.1 LOADER ATTACHMENT DIMENSIONS AND PERFORMANCE 13

 4.2 DIMENSIONS AND PERFORMANCE OF LOADER ATTACHMENT WITH FORKS 19

 4.3 BACKHOE ATTACHMENT DIMENSIONS AND PERFORMANCE 20

5. BACKHOE ATTACHMENT LIFTING CAPACITY 26

6. MAXIMUM LIFTING LOADS 29

 6.1 LOADER ATTACHMENT MAXIMUM LIFTING LOAD TABLE 29

 6.2 BACKHOE ATTACHMENT MAXIMUM LIFTING LOAD TABLE 30

7. SUPPLY SUMMARY TABLE 31

SECTION 17 - TORQUE CONVERTERS

1. POWERSHUTTLE TORQUE CONVERTER 3

 1.1 DESCRIPTION AND OPERATION 3

 1.2 SPECIFICATIONS 4

 1.3 OVERHAUL 4

 1.4 INSPECTION 4

 1.5 DISASSEMBLY AND ASSEMBLY 5

 1.6 STALL TEST 5

 1.7 FAULT FINDING 6

2. POWERSHIFT TORQUE CONVERTER 7

 2.1 DESCRIPTION AND OPERATION 7

 2.2 SPECIFICATIONS 8

 2.3 OVERHAUL 8

 2.4 INSPECTION 9

 2.5 DISASSEMBLY AND ASSEMBLY 9

 2.6 STALL TEST 11

 2.7 FAULT FINDING 12

SECTION 21 - TRANSMISSION

1. POWERSHUTTLE TRANSMISSION "TURNER MODEL COM-T4-2025"	3
1.1 SPECIFICATIONS	3
1.2 MOUNTING SCREW TORQUE	5
1.3 TRANSMISSION CONTROLS	6
1.4 LUBRICATION	11
1.5 TRANSMISSION OIL FLOW AND SUPPLY	12
1.6 TRANSMISSION HYDRAULIC VALVES AND PRESSURE TEST POINTS	18
1.7 TRANSMISSION POWER FLOW	19
1.8 TRANSMISSION 2WD COMPONENTS	23
1.9 TRANSMISSION 4WD COMPONENTS	26
1.10 TRANSMISSION REMOVAL	31
1.11 DISASSEMBLY AND ASSEMBLY	32
1.12 FAULT FINDING	90
1.13 SPECIAL TOOLS	93
2. POWERSHIFT TRANSMISSION "DANA T16000"	94
2.1 SPECIFICATIONS	94
2.2 CONTROLS	95
2.3 LUBRICATION	105
2.4 PRESSURE SPECIFICATIONS AND CHECK POINTS	106
2.5 TRANSMISSION COOLER	108
2.6 HYDRAULIC DIAGRAM	109
2.7 OPERATION	110
2.8 POWER FLOWS	117
2.9 GEAR AND CLUTCH LAY OUT	132
2.10 TRANSMISSION REMOVAL AND INSTALLATION	133
2.11 TRANSMISSION COMPONENTS	137
2.12 DISASSEMBLY AND ASSEMBLY	155
2.13 SPECIAL TOOLS	264
2.14 FAULT FINDING	265
2.15 FAULT FINDING	267

SECTION 25 - FRONT AXLES

1. FRONT AXLE 2WD "CARRARO"	3
1.1 SPECIFICATIONS	3
1.2 DISASSEMBLY AND ASSEMBLY	6
1.3 FAULT FINDING	24
2. FRONT AXLE 4WD "CARRARO"	26
2.1 SPECIFICATIONS	26
2.2 DISASSEMBLY AND ASSEMBLY	31
2.3 FAULT FINDING	77
3. FRONT AXLE 4WS "CARRARO"	80
3.1 SPECIFICATIONS	80
3.2 DISASSEMBLY AND ASSEMBLY	84
3.3 FAULT FINDING	137
4. SPECIAL TOOLS	140

SECTION 27 - REAR AXLE

1. REAR AXLE 2WS	3
1.1 DESCRIPTION AND OPERATION.....	3
1.2 SPECIFICATIONS	6
1.3 DISASSEMBLY AND ASSEMBLY.....	8
1.4 FAULT FINDING	27
2. REAR AXLE 4WS "CARRARO".....	28
2.1 SPECIFICATIONS	28
2.2 DISASSEMBLY AND ASSEMBLY.....	32
2.3 FAULT FINDING.....	81
3. SPECIAL TOOLS.....	84

SECTION 33 - BRAKES SYSTEM

1. SPECIFICATIONS	3
2. PARKING BRAKE.....	6
2.1 PARKING BRAKE ADJUSTMENT	7
3. BRAKE CYLINDERS	8
4. OIL BRAKE TANK	13
5. BLEEDING PROCEDURE.....	13

SECTION 35 - HYDRAULIC SYSTEM

1. HYDRAULIC DIAGRAMS	3
1.1 HYDRAULIC DIAGRAM - 2WS SIDESHIFT MECHANICAL MODELS.....	3
1.2 HYDRAULIC DIAGRAM - 2WS SIDESHIFT PILOT MODELS.....	5
1.3 HYDRAULIC DIAGRAM - 4WS SIDESHIFT MECHANICAL MODELS.....	7
1.4 HYDRAULIC DIAGRAM - 4WS SIDESHIFT PILOT MODELS.....	9
1.5 HYDRAULIC DIAGRAM - 4WS CENTER PIVOT PILOT MODELS	11
2. HYDRAULIC PUMP	13
2.1 DESCRIPTION AND OPERATION.....	13
2.2 SPECIFICATIONS	13
2.3 LOAD SENSING VALVE	16
2.4 REMOVAL	18
2.5 COMPONENTS	19
2.6 DISASSEMBLY AND ASSEMBLY.....	20
3. CONTROL VALVES	24
3.1 CONTROL VALVES "REXROTH" (MECHANICAL MODELS)	24
3.2 "REXROTH" CONTROL VALVES (PILOT MODELS)	40
3.3 SOLENOID VALVE FOR PILOTING THE BACKHOE CONTROL VALVE (WITH HYDRAULIC CONTROL)	49
3.4 RELIEF VALVES	52
3.5 ACCUMULATOR "GLIDE RIDE" PARKER.....	60
4. HYDRAULIC SWING SYSTEM	63
4.1 DESCRIPTION AND OPERATION.....	63
4.2 HYDRAULIC OIL FLOW	64
5. HYDRAULIC CYLINDERS.....	66
5.1 LOADER ATTACHMENT BOOM CYLINDER	67
5.2 LOADER BUCKET CYLINDER	72
5.3 4X1 LOADER BUCKET CYLINDER.....	76

5.4 BACKHOE BOOM CYLINDER	79
5.5 BACKHOE ATTACHMENT DIPPER CYLINDER	83
5.6 BACKHOE BUCKET CYLINDER	87
5.7 TELESCOPIC CYLINDER	91
5.8 4WS STABILIZER CYLINDER - CENTER PIVOT	95
5.9 STABILIZER CYLINDER - SIDESHIFT	99
5.10 SWING CYLINDER.....	103
5.11 BACKHOE ATTACHMENT SIDESHIFT CYLINDER - SIDESHIFT	107
5.12 SPECIAL TOOLS.....	108
6. HYDRAULIC CONTROL LEVERS.....	109
6.1 SPECIFICATIONS	109
6.2 DESCRIPTION AND OPERATION.....	110
6.3 DISASSEMBLY AND ASSEMBLY	113
6.4 CONTROL LEVER VALVE	116
7. FAULT FINDING	119
7.1 PRELIMINARY CHECKS.....	119
7.2 FAULT FINDING	120

SECTION 39 - CHASSIS

1. DESCRIPTION AND OPERATION.....	3
2. REMOVAL AND INSTALLATION COMPONENTS.....	5
2.1 COMPONENTS WITHIN THE CHASSIS.....	5
2.2 COMPONENTS BELOW THE CHASSIS	6
2.3 COMPONENTS ATTACHED OUTSIDE THE CHASSIS	8
2.4 COMPONENTS ATTACHED ON THE CHASSIS.....	9
2.5 MOUNTING SCREW TORQUE.....	11

SECTION 41 - STEERING SYSTEM

1. STEERING SYSTEM 2WS	4
2. STEERING SYSTEM 4WS	7
3. POWER STEERING	12
3.1 SPECIFICATIONS	13
3.2 COMPONENTS	15
3.3 DISASSEMBLY AND ASSEMBLY	16
3.4 SPECIAL TOOLS.....	33
3.5 FAULT FINDING	33

SECTION 50 - CAB HEATING AND AIR CONDITIONING

1. SPECIFICATIONS	3
2. CAB HEATING.....	5
2.1 DESCRIPTION AND OPERATION.....	5
3. AIR CONDITIONING.....	12
3.1 PRINCIPALS OF AIR CONDITIONING	12
3.2 SAFETY PRECAUTIONS	16
3.3 CONTROLS AND OPERATION	17
3.4 FAULT FINDING AND TESTING.....	26
3.5 FLUSHING THE SYSTEM.....	44
3.6 EVACUATING THE SYSTEM.....	46
3.7 CHARGING THE SYSTEM.....	47

3.8 COMPONENTS OVERHAUL	48
3.9 COMPRESSOR	53
3.10 SPECIAL TOOLS.....	67

SECTION 55 - ELECTRICAL SYSTEM

1. GENERALITIES.....	3
1.1 TEMPORARY WIRING HARNESS REPAIR	3
1.2 FAULT FINDING	4
2. ELECTRICAL DIAGRAMS.....	5
2.1 ELECTRICAL DIAGRAMS - POWERSHUTTLE ROPS (580SR).....	5
2.2 ELECTRICAL DIAGRAMS - POWERSHUTTLE CAB (580SR).....	20
2.3 ELECTRICAL DIAGRAMS - POWERSHIFT CAB (580SR).....	36
2.4 ELECTRICAL DIAGRAMS - POWERSHUTTLE CAB (580SR+/590SR)	54
2.5 ELECTRICAL DIAGRAMS - POWERSHIFT CAB (590SR).....	69
2.6 ELECTRICAL DIAGRAMS - 4WS POWERSHIFT CAB (695SR).....	84
3. CONTROLS AND INSTRUMENTS	100
3.1 FRONT CONTROL PANELS (580SR / 590SR)	100
3.2 FRONT CONTROL PANELS (695SR)	102
3.3 SIDE INSTRUMENT CLUSTER PANEL (580SR).....	104
3.4 SIDE INSTRUMENT CLUSTER PANEL (580SR+ / 590SR / 695SR).....	106
3.5 SIDE INSTRUMENT CLUSTER (580SR).....	108
3.6 SIDE INSTRUMENT CLUSTER (580SR+ / 590SR / 695SR).....	110
3.7 IMMOBILISER CIRCUIT.....	112
4. DIAGNOSTIC DISPLAY (580SR+ / 590SR / 695SR).....	113
4.1 SYMBOLS.....	114
4.2 SETUP MENU	115
4.3 PROCEDURE ABOUT SELF TEST	116
4.4 ON BOARD ERROR CODE RETRIEVAL	117
4.5 BACKLIGHTING AND DIMMING.....	118
4.6 WORK HOURS.....	119
4.7 FUNCTIONAL DESCRIPTION	120
4.8 WARNING SYSTEM.....	124
4.9 MAINTENANCE.....	126
4.10 WARNING MESSAGES	127
5. STARTING SYSTEM	134
5.1 DESCRIPTION AND OPERATION.....	134
5.2 FAULT FINDING.....	135
5.3 STARTER MOTOR.....	138
6. ALTERNATOR.....	144
6.1 SPECIFICATIONS.....	144
6.2 DESCRIPTION AND OPERATION.....	144
6.3 COMPONENTS	146
6.4 REMOVAL	147
6.5 PRELIMINARY CHECK AND TESTS.....	148
6.6 FAULT FINDING.....	157
7. BATTERY	158
7.1 SPECIFICATIONS.....	158
7.2 DESCRIPTION AND OPERATION.....	158
7.3 BATTERY REPLACEMENT	159
7.4 MAINTENANCE.....	161
7.5 TESTS	163

7.6 CONNECTING A BOOSTER BATTERY	165
7.7 BATTERY MASTER SWITCH	165
8. COMPONENT TESTING	166
8.1 GENERAL INTRODUCTION	166
8.2 COMPONENT TESTING	167
8.3 GROUND POINTS.....	167
8.4 ALTERNATOR	170
8.5 TRANSMISSIONS	170
8.6 PARKING BRAKE SWITCH.....	174
8.7 CAB.....	175
8.8 4WD SWITCH	180
8.9 BRAKE PEDAL SWITCHES	180
8.10 BRAKE OIL LEVEL WARNING LAMP	181
8.11 FRONT WORK LAMP SWITCH (1) - REAR WORK LAMP SWITCH (2) MAIN LIGHT SWITCH....	181
8.12 HAZARD SWITCH	182
8.13 HAZARD WARNING LIGHT RELAY.....	182
8.14 MULTI FUNCTION SWITCH.....	183
8.15 FRONT WINDSHIELD WIPER MOTOR (1) - REAR WINDSHIELD WIPER MOTOR (2)	183
8.16 4WS - STEERING SELECTOR SWITCH	184
8.17 STEERING CONTROL UNIT.....	185
8.18 4WS REAR AXLE STEERING SENSOR.....	187
8.19 4WS FRONT AXLE STEERING SENSOR	187
8.20 STEERING SOLENOID VALVE.....	188
8.21 DIFFERENTIAL LOCK SWITCH (1)	189
8.22 LOADER	190
8.23 BACKHOE.....	193

SECTION 82 - LOADER

1. LOADER ATTACHMENT CONTROLS.....	3
1.1 LOADER ATTACHMENT OPERATION.....	3
2. LOADER BUCKET SELF LEVELING	6
3. LOADER ATTACHMENT SAFETY STRUT.....	7
4. LOADER BUCKET REMOVAL	8
5. LOADER REMOVAL.....	11

SECTION 84 - BACKHOE

1. DESCRIPTION AND OPERATION.....	3
2. BACKHOE ATTACHMENT MECHANICAL CONTROLS VERSION	6
3. BACKHOE ATTACHMENT HYDRAULIC CONTROLS	15
4. REMOVAL AND INSTALLATION	17
4.1 CENTER PIVOT BACKHOE ATTACHMENT DISASSEMBLY	17
4.2 BACKHOE ATTACHMENT DISASSEMBLY - SIDESHIFT.....	20
4.3 BACKHOE BUCKET REMOVAL	23
4.4 BUCKET TEETH REPLACEMENT.....	23
4.5 DIPPER REMOVE	24
5. TELESCOPIC DIPPER REVISION.....	27
6. TELESCOPIC DIPPER REVISION.....	27
7. REVISIONE DEL BRACCIO TELESCOPICO.....	27

580SR
580SR+
590SR
695SR



SECTION 00 - SAFETY PRECAUTIONS

This warning symbol points out important messages involving personal safety.

Carefully read the safety rules contained herein and follow advised precautions to avoid potential hazards and safeguard your safety and personal integrity.

In this manual you will find this symbol together with the following keywords:

WARNING - it gives warning about improper repair operations and deriving potential consequences affecting the service technician's personal safety.

DANGER - it gives specific warning about potential dangers for personal safety of the operator or other persons directly or indirectly involved.



TO PREVENT ACCIDENTS

Most accidents and personal injuries that occur in the work site or on the road, are caused by the failure of some individual to follow simple and fundamental safety rules or precautions.

For this reason, **MOST ACCIDENTS CAN BE PREVENTED**: by recognizing the real cause and taking the necessary precautions, before the accident occurs.

Regardless of the care used in design and construction of any type of equipment, there may be conditions that cannot be completely safeguarded against, without interfering with reasonable accessibility and efficient operation.

A careful operator or technician is the best precaution against accidents. The complete observance of one simple rule would prevent many thousands of serious injuries each year.

This rule is: never attempt to clean, lubricate or adjust a machine while it is in motion.

SAFETY PRECAUTIONS

- Carefully follow specified repair and maintenance procedures.
 - Do not wear rings, wristwatches, jewels, unbuttoned or flapping clothing such as: ties, torn clothes, scarves, open jackets or shirts with open zips which could get hold into moving parts. We advise to use approved safety clothing such as: anti-slipping footwear, gloves, safety goggles, helmets, etc.
 - Never carry out any repair on the machine if someone is sitting on the operator's seat, except if they are certified operators to assist in the operation to be carried out.
 - Never operate the machine or use attachments from a place other than sitting at the operator's seat.
 - Never carry out any operation on the machine when the engine is running, except when specifically indicated.
 - Stop the engine and ensure that all pressure is relieved from hydraulic circuits before removing caps, covers, valves, etc.
 - All repair and maintenance operations should be carried out with the greatest care and attention.
 - Service stairs and platforms used in a workshop or in the field should be built in compliance with the safety rules in force.
 - Disconnect the batteries and label all controls to warn that the Machine is being serviced. Block the machine and all equipment which should be raised.
 - Never check or fill fuel tanks and accumulator batteries, nor use starting liquid if you are smoking or near open flames as such fluids are flammable.
 - Brakes are inoperative when they are manually released for maintenance purposes. In such cases, the machine should be kept constantly under control using blocks or similar devices.
 - The fuel filling gun should remain always in contact with the filler neck. Maintain this contact until the fuel stops flowing into the tank to avoid possible sparks due to static electricity buildup.
 - Use exclusively specified towing points for towing the machine. Connect parts carefully. Ensure that foreseen pins and/or locks are steadily fixed before applying traction. Do not stop near towing bars, cables or chains working under load.
 - To transfer a failed machine, use a trailer or a low loading platform trolley if available.
 - To load and unload the machine from the transportation mean, select a flat area providing a firm support to the trailer or truck wheels. Firmly tie the machine to the truck or trailer platform and block wheels as required by the forwarder.
 - For electrical heaters, battery-chargers and similar equipment use exclusive auxiliary power supplies with a efficient ground to avoid electrical shock hazard.
 - Always use lifting equipment and similar of appropriate capacity to lift or move heavy components.
 - Pay special attention to bystanders.
 - Never pour gasoline or diesel oil into open, wide and low containers.
 - Never use gasoline, diesel oil or other flammable liquids as cleaning agents. Use non-flammable non-toxic proprietary solvents.
 - Wear protection goggles with side guards when cleaning parts using compressed air.
 - Do not exceed a pressure of 2.1 bar, in accordance with local regulations.
 - Do not run the engine in a closed building without proper ventilation.
 - Do not smoke, use open flames, cause sparks in the nearby area when filling fuel or handling highly flammable liquids.
 - Do not use flames as light sources when working on a machine or checking for leaks.
 - Move with caution when working under a Machine, and also on or near a Machine. Wear proper safety accessories: helmets, goggles and special footwear.
 - During checks which should be carried out with the engine running, ask an assistant to sit at the operator's seat and keep the service technician under visual control at any moment. In case of operations outside the workshop, drive the machine to a flat area and block it. If working on an incline cannot be avoided, first block the Machine carefully. Move it to a flat area as soon as possible with a certain extent of safety.
 - Ruined or plied cables and chains are unreliable. Do not use them for lifting or trailing. Always handle them wearing gloves of proper thickness.
 - Chains should always be safely fastened. Ensure that fastening device is strong enough to hold the load foreseen. No persons should stop near the fastening point, trailing chains or cables.
 - The working area should be always kept CLEAN and DRY. Immediately clean any spillage of water or oil.
 - Do not pile up grease or oil soaked rags: they constitute a great fire hazard. Always place them into a metal container. Before starting the Machine or its attachments, check, adjust and block the operator's seat. Also ensure that there are no persons within the Machine or attachment operating range.
 - Do not keep in your pockets any object which might fall unobserved into the Machine's inner compartments.
-

- Whenever there is the possibility of being reached by ejected metal parts or similar, use protection eye mask or goggles with side guards, helmets, special footwear and heavy gloves. Whenever it is necessary to carry out welding operations, it is necessary to wear suitable personal protective devices: tinted eye protection, helmets, special clothing, gloves and safety shoes. All persons standing in the vicinity of the welding process should wear tinted eye protection. **NEVER LOOK AT THE WELDING ARC IF YOUR EYES ARE NOT SUITABLY PROTECTED.**
- Metal cables with the use get frayed. Always wear adequate protections (heavy gloves, eye protection, etc.).
- Handle all parts with the greatest caution. Keep your hands and fingers far from gaps, moving gears and similar. Always use approved protective equipment, such as eye protection, heavy gloves and protective footwear.

START UP

- Never run the engine in confined spaces which are not equipped with adequate ventilation for exhaust gas extraction.
- Never bring your head, body, arms, legs, feet, hands, fingers near fans or rotating belts.

ENGINE

- Always loosen the radiator cap very slowly before removing it to allow pressure in the system to dissipate. Coolant should be topped up only when the engine is stopped or idle if hot.
- Do not fill up fuel tank when the engine is running, mainly if it is hot, to avoid ignition of fires in case of fuel spilling.
- Never check or adjust the fan belt tension when the engine is running. Never adjust the fuel injection pump when the machine is moving.
- Never lubricate the machine when the engine is running.

ELECTRICAL SYSTEMS

- If it is necessary to use auxiliary batteries, cables must be connected at both sides as follows: (+) to (+) and (-) to (-). Avoid short-circuiting the terminals. **GAS RELEASED FROM BATTERIES IS HIGHLY FLAMMABLE.** During charging, leave the battery compartment uncovered to improve ventilation. Avoid checking the battery charge by means of "jumpers" made by placing metallic objects across the terminals. Avoid sparks or flames near the battery area. Do not smoke to prevent explosion hazards.
- Prior to any service, check for fuel or coolant leaks. Remove these leaks before going on with the work. Do not charge batteries in confined spaces. Ensure that ventilation is appropriate to prevent accidental explosion hazard due to build-up of gasses relieved during charging.

- Always disconnect the batteries before performing any type of service on the electrical system.

HYDRAULIC SYSTEMS

- Some fluid slowly coming out from a very small port can be almost invisible and be strong enough to penetrate the skin. For this reason, use a piece of cardboard or a piece of wood for checking. **NEVER USE YOUR HANDS.** If any fluid is injected into the skin, seek medical aid immediately. Lack of immediate medical attention, serious infections or dermatitis may result.
- Always take system pressure readings using the appropriate gauges.

WHEELS AND TYRES

- Check that the tyres are correctly inflated at the pressure specified by the manufacturer. Periodically check possible damages to the rims and tyres.
- Keep off and stay at the tyre side when correcting the inflation pressure.
- Check the pressure only when the machine is unloaded and tyres are cold to avoid wrong readings due to over-pressure. Do not reuse parts of recovered wheels as improper welding, brazing or heating may weaken the wheel and make it fail.
- Never cut, nor weld a rim with the inflated tyre assembled.
- To remove the wheels, block both front and rear Machine wheels. Raise the Machine and install safe and stable supports under the Machine in accordance with regulations in force.
- Deflate the tyre before removing any object caught into the tyre tread.
- Never inflate tyres using flammable gases as they may originate explosions and cause injuries to bystanders.

REMOVAL AND INSTALLATION

- Lift and handle all heavy components using lifting equipment of adequate capacity. Ensure that parts are supported by appropriate slings and hooks. Use lifting eyes provided to this purpose. Take care of the persons near the loads to be lifted.
- Handle all parts with great care. Do not place your hands or fingers between two parts. Wear approved protective clothing such as safety goggles, gloves and footwear.
- Do not twist chains or metal cables. Always wear protection gloves to handle cables or chains.

IMPORTANT ECOLOGICAL CONSIDERATIONS

The following are recommendations which may be of assistance:

- Become acquainted with and ensure that you understand the relative legislation applicable to your country.
- Where no legislation exists, obtain information from suppliers of oils, fuels, antifreeze, cleaning agents, etc., with regard to their effect on man and nature and how to safely store, use and dispose of these substances.

Helpful hints

- Avoid filling tanks using jerry cans or inappropriate pressurized fuel delivery systems which may cause considerable spillage.
 - In general, avoid skin contact with all fuels, oils, acids, solvents, etc.
Most of them contain substances which can be harmful to your health.
 - Modern oils contain additives. Do not burn contaminated fuels and/or waste oils in ordinary heating systems.
 - Avoid spillage when draining off used engine coolant mixtures, engine, transmission and hydraulic oils, brake fluids, etc.
Do not mix drained brake fluids or fuels with lubricants. Store them safely until they can be disposed of in a proper way to comply with local legislation and available resources.
 - Modern coolant mixtures, i.e. antifreeze and other additives, should be replaced every two years. They should not be allowed to get into the soil but should be collected and disposed of safely.
 - Do not open the Air-Conditioning system yourself. It may contain gases which should not be released into the atmosphere. Your air conditioning specialist has special equipment for discharging and charging the system.
 - Repair any leaks or defects in the engine cooling or hydraulic system immediately.
 - Do not increase the pressure in a pressurized system as this may lead to a catastrophic failure of the system components.
 - Protect hoses during welding as penetrating weld chips may burn a hole or weaken them, causing the loss of oils, coolant, etc.
-

580SR
580SR+
590SR
695SR



SECTION 01 - MAINTENANCE

All maintenance and repair operations described in this manual should be carried out exclusively by authorized workshops. All instructions detailed should be carefully observed and special equipment indicated should be used if necessary. Everyone who carries out service operations described without carefully observing these prescriptions will be directly responsible of deriving damages.

GENERAL

Clean the exterior of all components before carrying out any form of repair. Dirt and dust can reduce the efficient working life of a component and lead to costly replacement.

Time spent on the preparation and cleanliness of working surfaces will pay dividends in making the job easier and safer and will result in overhauled components being more reliable and efficient in operation. Use cleaning fluids which are known to be safe. Certain types of fluid can cause damage to O-rings and cause skin irritation. Solvents should be checked that they are suitable for the cleaning of components and also that they do not risk the personal safety of the user. Replace O-rings, seals or gaskets whenever they are disturbed. Never mix new and old seals or O-rings, regardless of condition. Always lubricate new seals and O-rings with hydraulic oil before installation. When replacing component parts, use the correct tool for the job.

HOSES AND TUBES

Always replace hoses and tubes if the cone end or the end connections on the hose are damaged.

When installing a new hose, loosely connect each end and make sure the hose takes up the designed position before tightening the connection. Clamps should be tightened sufficiently to hold the hose without crushing and to prevent chafing. After hose replacement to a moving component, check that the hose does not foul by moving the component through the complete range of travel. Be sure any hose which has been installed is not kinked or twisted. Hose connections which are damaged, dented, crushed or leaking, restrict oil flow and the productivity of the components being served. Connectors which show signs of movement from the original swagged position have failed and will ultimately separate completely.

A hose with a chafed outer cover will allow water entry. Concealed corrosion of the wire reinforcement will subsequently occur along the hose length with resultant hose failure.

Ballooning of the hose indicates an internal leakage due to structural failure. This condition rapidly deteriorates and total hose failure soon occurs.

Kinked, crushed, stretched or deformed hoses generally suffer internal structural damage which can result in oil restriction, a reduction in the speed of operation and ultimate hose failure.

Free-moving, unsupported hoses must never be allowed to touch each other or related working surfaces. This causes chafing which reduces hose life.

O-RING FLAT FACE SEAL FITTINGS

When repairing O-ring face seal connectors, the following procedures should be observed.

WARNING

Never disconnect or tighten a hose or tube that is under pressure, if in doubt, actuate the operating levers several times with the engine switched off prior to disconnecting a hose or tube.

Release the fittings and separate the hose or tube assembly, then remove and discard the O-ring seal from the fitting. Dip a new O-ring seal into clean hydraulic oil prior to installation. Install a new O-ring into the fitting and, if necessary, retain in position using petroleum jelly. Assemble the new hose or tube assembly and tighten the fitting finger tight, while holding the tube or hose assembly to prevent it from turning. Use two suitable wrenches and tighten the fitting to the specified torque according to the size of the fitting.

NOTE: to ensure a leak-free joint is obtained, it is important that the fittings are not over or under torqued.

SHIMMING

At each adjustment, select adjusting shims, measure them individually using a micrometre and then sum up recorded values.

Do not rely on measuring the whole shimming set, which may be incorrect, or on rated value indicated for each shim.

ROTATING SHAFT SEALS

To correctly install rotating shaft seals, observe the following instructions:

- let the seal soak into the same oil as it will seal for at least half an hour before mounting;
 - thoroughly clean the shaft and ensure that the shaft working surface is not damaged;
-

- place the sealing lip towards the fluid. In case of a hydrodynamic lip, consider the shaft rotation direction and orient grooves in order that they deviate the fluid towards the inner side of the seal;
- coat the sealing lip with a thin layer of lubricant (oil rather than grease) and fill with grease the gap between the sealing lip and the dust lip of double lip seals;
- insert the seal into its seat and press it down using a flat punch. Do not tap the seal with a hammer or a drift;
- take care to insert the seal perpendicularly to its seat while you are pressing it. Once the seal is settled, ensure that it contacts the thrust element if required;
- to prevent damaging the sealing lip against the shaft, place a suitable protection during installation.

O-RINGS

Lubricate the O-rings before inserting them into their seats. This will prevent the O-rings from rolling over and twisting during mounting which will jeopardize sealing.

BEARINGS

It is advisable to heat the bearings to 80 to 90 °C before mounting them on their shafts and cool them down before inserting them into their seats with external tapping.

SPRING PINS

When mounting split socket spring pins, ensure that the pin notch is oriented in the direction of the effort to stress the pin.

Spiral spring pins should not be oriented during installation.

HARDWARE TORQUE VALUES

Check the tightness of hardware periodically. Use the following charts to determine the correct torque when checking, adjusting or replacing hardware on the Backhoe loader.

IMPORTANT: Torque values listed are for general use only. Make sure fastener threads are clean and not damaged.

NOTE: a torque wrench is necessary to properly torque hardware.

NOTES FOR SPARE PARTS

Only genuine parts guarantee same quality, life, safety as original components as they are the same as mounted in production. Only the genuine spare parts can offer this guarantee.

All spare parts orders should be complete with the following data:

- machine model (commercial name) and chassis number;
- engine type and number;
- part number of the ordered part, which can be found on the "Spare Parts Catalogue", which is the base for order processing.

NOTES FOR EQUIPMENT

Equipment which proposes and shows in this manual are as follows:

- studied and designed expressly for use on company machines;
- necessary to make a reliable repair;
- accurately built and strictly tested to offer efficient and long-lasting working means.

We also remind the repair personnel that having these equipment means:

- work in optimal technical conditions;
- obtain best results;
- save time and effort;
- work more safely.

CAUTION

Wear limits indicated for some details should be intended as advised, but not binding values. The words "front", "rear", "right hand", and "left hand" referred to the different parts should be intended as seen from the operator's seat oriented to the normal sense of movement of the machine.

HOW TO MOVE THE MACHINE WITH THE BATTERY REMOVED

Cables from the external power supply should be connected exclusively to the respective terminals of the Machine positive and negative cables using pliers in good condition which allow proper and steady contact.

Disconnect all services (lights, wind-shield wipers, etc.) before starting the Machine.

If it is necessary to check the machine electrical system, check it only with the power supply connected. At check end, disconnect all services and switch the power supply off before disconnecting the cables.

580SR
580SR+
590SR
695SR

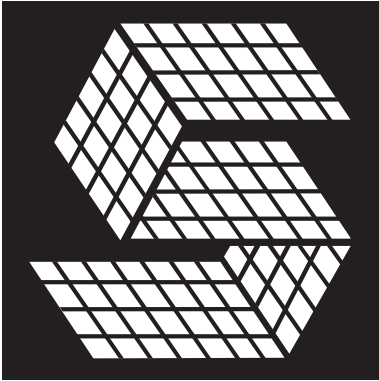

SECTION 02 - TECHNICAL SPECIFICATIONS

- 1. LOADER BACKHOE MODELS 3
- 2. IDENTIFICATION OF MAIN COMPONENTS 4
- 3. SPECIFICATIONS 6
 - 3.1 DIESEL ENGINE 6
 - 3.2 TRANSMISSION..... 8
 - 3.3 AXLES 9
 - 3.4 BRAKES 9
 - 3.5 STEERING..... 10
 - 3.6 HYDRAULIC SYSTEM 10
 - 3.7 FRONT COUNTERWEIGHT 10
 - 3.8 NOISE AND VIBRATION LEVELS 11
 - 3.9 BUCKETS..... 11
 - 3.10 TYRES..... 12
- 4. DIMENSIONS AND PERFORMANCE..... 13
 - 4.1 LOADER ATTACHMENT DIMENSIONS AND PERFORMANCE 13
 - 4.2 DIMENSIONS AND PERFORMANCE OF LOADER ATTACHMENT WITH FORKS..... 19
 - 4.3 BACKHOE ATTACHMENT DIMENSIONS AND PERFORMANCE 20
- 5. BACKHOE ATTACHMENT LIFTING CAPACITY 26
- 6. MAXIMUM LIFTING LOADS..... 29
 - 6.1 LOADER ATTACHMENT MAXIMUM LIFTING LOAD TABLE 29
 - 6.2 BACKHOE ATTACHMENT MAXIMUM LIFTING LOAD TABLE 30
- 7. SUPPLY SUMMARY TABLE 31

1. LOADER BACKHOE MODELS

	580SR	580SR+	590SR	695SR
Powershift	/	•	•	•
Powershuttle	•	•	•	/
Stabilizer sideshift	•	•	•	•
Stabilizer center pivot	/	/	/	•
Cab	•	•	•	•
Rops	•	/	/	/
2WD	•	/	/	/
4WD	•	•	•	•
4WS	/	/	/	•
Pilot control	•	•	•	•
Mechanical control	•	•	•	•
Engine 72 kW-97 HP model F4GE948C*601 (mechanical)	•	/	/	/
Engine 72 kW-97 HP model F4HE0484C*J102 (electronic)	/	•	/	/
Engine 82 kW-110 HP model F4HE9484C*J102 (electronic)	/	/	•	/
Engine 82 kW-110 HP model F4HE9484C*J103 - 4WS (electronic)	/	/	/	•
Short dipper	/	/	/	/
Long dipper	•	•	•	•

2. IDENTIFICATION OF MAIN COMPONENTS

SIDESHIFT VERSION (590SR for example)

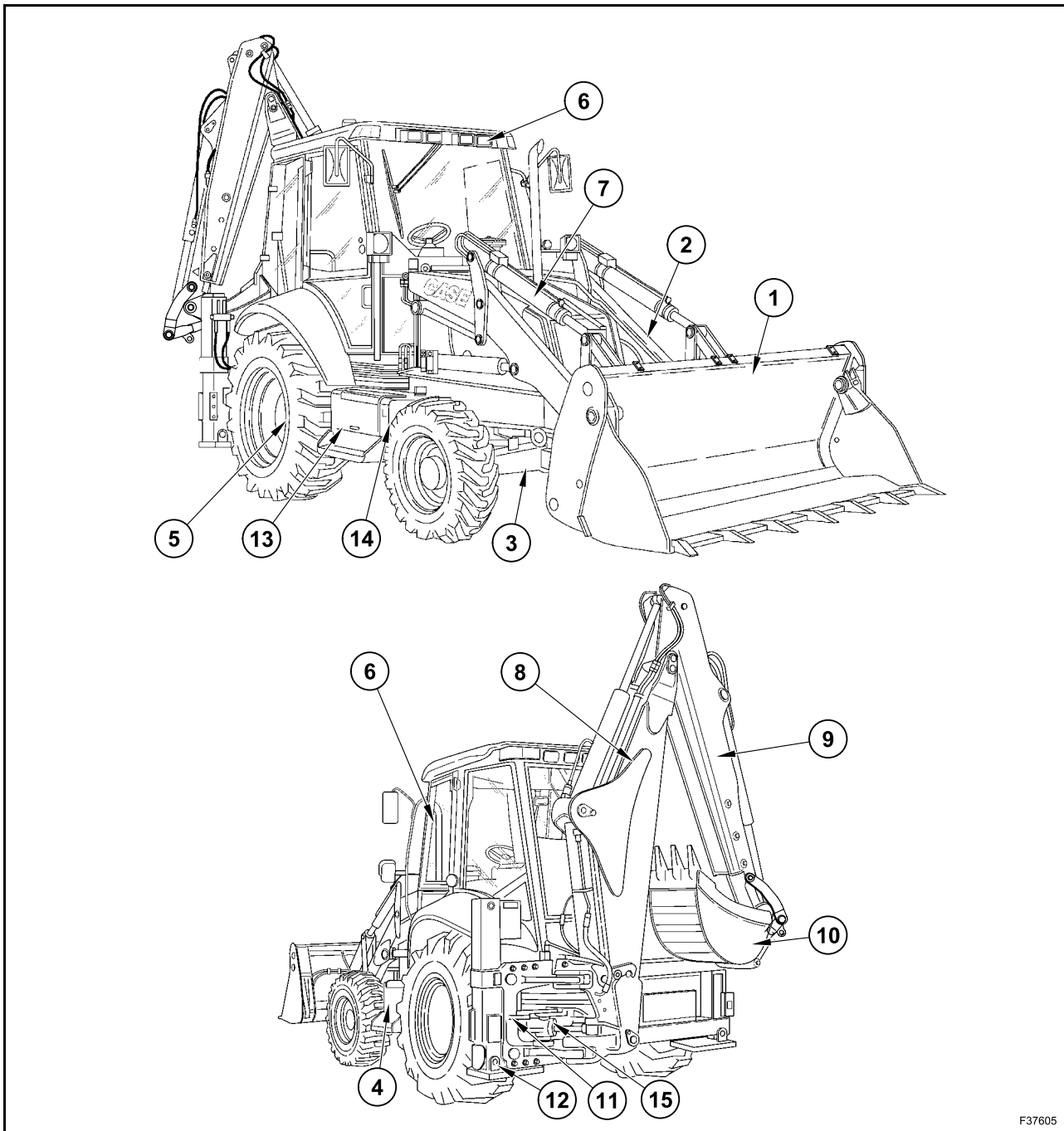

F37605

- | | |
|----------------------------|---|
| 1. Loader bucket | 9. Dipper or telescopic dipper |
| 2. Loader arm | 10. Backhoe bucket |
| 3. Front axle | 11. Backhoe attachment sideshift carriage |
| 4. Fuel tank | 12. Stabilizers |
| 5. Rear axle | 13. Battery box |
| 6. Operator's compartment | 14. Hydraulic oil tank |
| 7. Engine guard | 15. Swing cylinders |
| 8. Backhoe attachment boom | |

CENTER PIVOT VERSION (695SR for example)

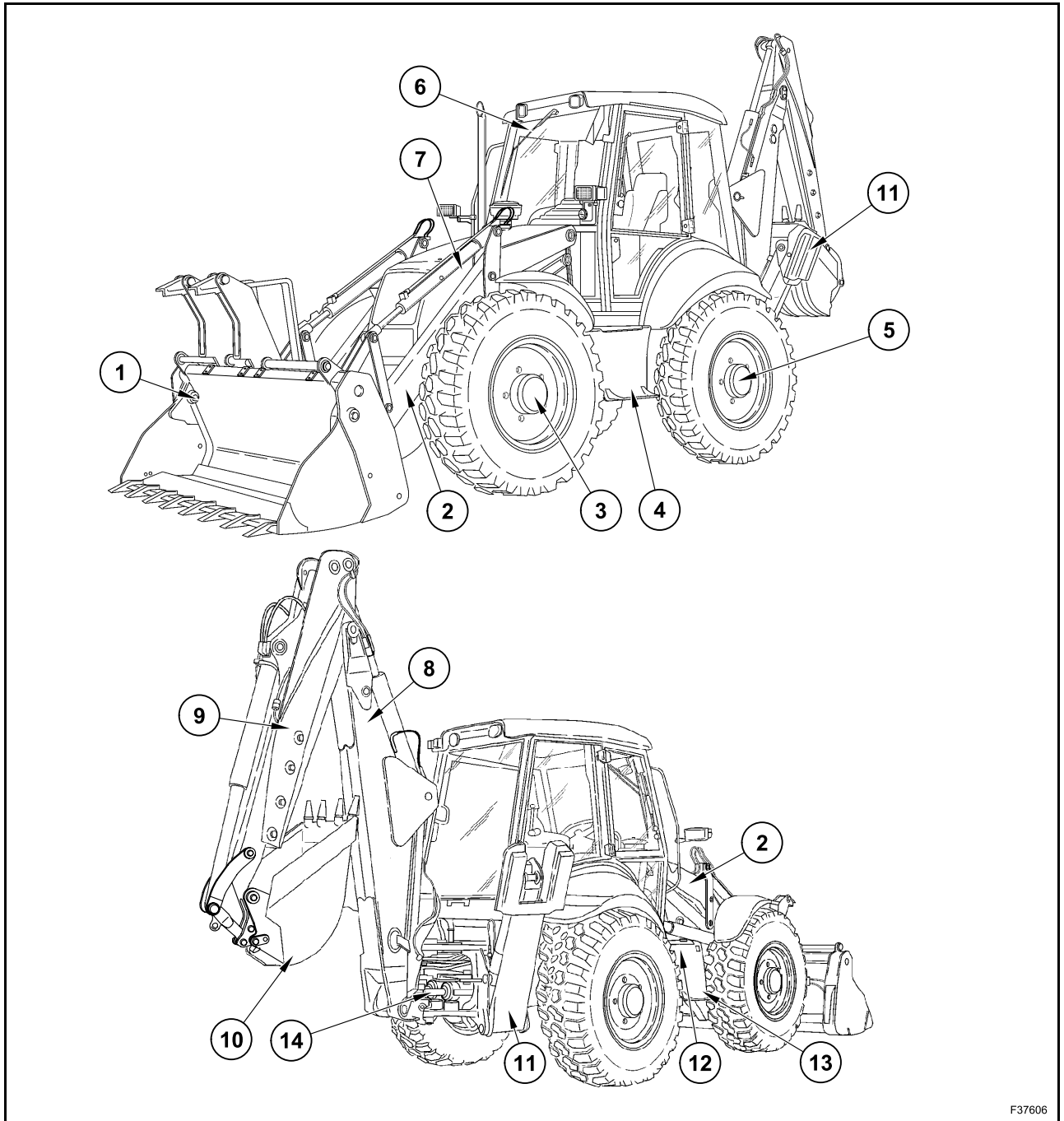

F37606

- | | |
|---------------------------|--------------------------------|
| 1. Loader bucket | 8. Backhoe attachment boom |
| 2. Loader arm | 9. Dipper or telescopic dipper |
| 3. Front axle | 10. Backhoe bucket |
| 4. Fuel tank | 11. Stabilizers |
| 5. Rear axle | 12. Battery box |
| 6. Operator's compartment | 13. Hydraulic oil tank |
| 7. Engine guard | 14. Swing cylinders |

3. SPECIFICATIONS

3.1 DIESEL ENGINE

72 kW - 97 HP ENGINE (580SR)

Specifications (EEC 88/195)	72 kW - 97 HP @ 2200 rpm
Model	F4GE9484C*601
Type	diesel, mechanical
No. of cylinders	4
Valves per cylinder	2
Bore.....	104 mm
Stroke.....	132 mm
Displacement	4485 cm ³
Compression ratio	17.5:1
Maximum torque (EC)	400 Nm @ 1400 rpm
Low idle speed at no load	1000 ± 50 rpm
High idle speed at no load (engine not installed)	2430 ± 50 rpm
High idle speed at no load (engine not installed on the vehicle)	2380 ± 60 rpm
Maximum speed at full load	2200 rpm
Air intake	TAA (turbocharged with aftercooler)

Supply

Type	direct injection
Injection pump.....	BOSCH ROTARY VE 4/12 F1100L
Injection sequence	1-3-4-2
Cold-start device	“grid heater” (optional)

Cooling

Pump type	H ₂ O pump
Pump drive	belt drive
Temperature switch (opening start)	81 ± 2 °C

72 kW - 97 HP ENGINE (580SR+)

Specifications (EEC 88/195)	72 kW - 97 HP @ 2200 rpm
Model	F4HE0484G*J102
Type	diesel, electronic
No. of cylinders	4
Valves per cylinder	4
Bore.....	104 mm
Stroke.....	132 mm
Displacement	4485 cm ³
Compression ratio	17.5:1
Maximum torque (EC)	453 Nm @ 1400 rpm
Low idle speed at no load	950 ± 50 rpm
High idle speed at no load (engine not installed)	2430 ± 50 rpm
High idle speed at no load (engine not installed on the vehicle)	2380 ± 60 rpm
Maximum speed at full load	2200 rpm
Air intake	TAA (turbocharged with aftercooler)

Supply

Type	high-pressure, common rail
Injection pump.....	CP3 high-pressure pump
Control unit.....	EDC7
Injection sequence	1-3-4-2
Cold-start device	“grid heater” (optional)

Cooling

Pump type.....	H ₂ O pump
Pump drive.....	belt drive
Temperature switch (opening start).....	81 ± 2 °C

82 kW - 110 HP ENGINE (590SR / 695SR)

Specifications (EEC 88/195)	82 kW - 110 HP @ 2200 rpm
Model (590SR).....	F4HE9484C*J102
Model (695SR).....	F4HE9484C*J103
Type	diesel, electronic
No. of cylinders	4
Valves per cylinder	4
Bore	104 mm
Stroke.....	132 mm
Displacement	4485 cm ³
Compression ratio.....	17.5:1
Maximum torque (EC).....	516 Nm @ 1400 rpm
Low idle speed at no load	950 ± 50 rpm
High idle speed at no load (engine not installed)	2430 ± 50 rpm
High idle speed at no load (engine not installed on the vehicle)	2380 ± 60 rpm
Maximum speed at full load	2200 rpm
Air intake	TAA (turbocharged with aftercooler)

Supply

Type	high-pressure, common rail
Injection pump.....	CP3 high-pressure pump
Control unit.....	EDC7
Injection sequence	1-3-4-2
Cold-start device	“grid heater” (optional)

Cooling

Pump type.....	H ₂ O pump
Pump drive.....	belt drive
Temperature switch (opening start).....	81 ± 2 °C

3.2 TRANSMISSION

2WD/2WS TRANSMISSION - POWERSHUTTLE (580SR)

Model	Turner COM-T4-2025	
Type (4x4)	4 forward and 4 reverse travel gears	
Torque converter ratio	2.38	
Transmission ratios:		
1st forward travel.....	gear 4.824:1	reverse travel gear 4.020:1
2nd forward travel	gear 2.998:1	reverse travel gear 2.496:1
3rd forward travel	gear 1.408:1	reverse travel gear 1.173:1
4th forward travel	gear 0.792:1	reverse travel gear 0.660:1

4WD/2WS TRANSMISSION - POWERSHUTTLE (580SR+ / 590SR)

Model	Turner COM-T4-2025	
Type (4x4)	4 forward and 4 reverse travel gears	
Torque converter ratio	2.38	
Transmission ratios:		
1st forward travel.....	gear 4.824:1	reverse travel gear 4.020:1
2nd forward travel	gear 2.998:1	reverse travel gear 2.496:1
3rd forward travel	gear 1.408:1	reverse travel gear 1.173:1
4th forward travel	gear 0.792:1	reverse travel gear 0.660:1

4WD/2WS TRANSMISSION - POWERSHIFT (580SR+ / 590SR)

Model	Dana T16000	
Type (4x4)	4 forward and 2 reverse travel gears	
Torque converter ratio	2.261	
Transmission ratios:		
(upper output)		
1st forward travel.....	gear 4.863:1	reverse travel gear 4.085:1
2nd forward travel	gear 2.571:1	reverse travel gear 2.160:1
3rd forward travel	gear 1.284:1	
4th forward travel	gear 0.679:1	
(lower output)		
1st forward travel.....	gear 4.625:1	reverse travel gear 3.885:1
2nd forward travel	gear 2.446:1	reverse travel gear 2.055:1
3rd forward travel	gear 1.221:1	
4th forward travel	gear 0.646:1	

4WD/4WS TRANSMISSION - POWERSHIFT (695SR)

Model	Dana T16000	
Type (4x4)	4 forward and 2 reverse travel gears	
Torque converter ratio	2.261	
Transmission ratios:		
(upper output)		
1st forward travel.....	gear 4.863:1	reverse travel gear 4.085:1
2nd forward travel	gear 2.571:1	reverse travel gear 2.160:1
3rd forward travel	gear 1.284:1	
4th forward travel	gear 0.679:1	
(lower output)		
1st forward travel.....	gear 4.625:1	reverse travel gear 3.885:1
2nd forward travel	gear 2.446:1	reverse travel gear 2.055:1
3rd forward travel	gear 1.221:1	
4th forward travel	gear 0.646:1	

3.3 AXLES

FRONT AXLES

Front 2WD/2WS axle (580SR)

Model CARRARO 26.00
 Typesteering

Front 4WD/2WS axle (580SR / 590SR)

Model CARRARO 26.16
 Typesteering

Front 4WD/4WS axle (695SR)

Model CARRARO 26.28
 Typesteering

REAR AXLES

Rear 2WS axle (580SR / 590SR)

Model CNH D46
 Typerigid
 Differential lock (powershuttle axle) mechanical
 Differential lock (powershift axle) electrical

Rear 4WS axle (695SR)

Model CARRARO 26.32M
 Typesteering
 Differential lock electrical

3.4 BRAKES

BRAKES - 2WS

Service brake

Type wet multi-discs, 8 x axle (4 x half axle)
 Braking surface 1440 cm²

Parking brake

Type single disc on transmission

BRAKES - 4WS

Service brake

Type wet multi-discs, 6 x axle (3 x half axle)
 Braking surface 1440 cm²

Parking brake

Type single disc on transmission

3.5 STEERING

2WS	2 wheel steer
4WS	4 wheel steer
System pressure	177 ± 3 bar

POWER STEERING**2WS**

Model	DANFOSS OSPC 125 LS
Displacement	125 cm ³ /rev
Shock valve adjustment	225 bar
Pressure relief valve adjustment	170 bar

4WS

Model	DANFOSS OSPC 160 LS
Displacement	160 cm ³ /rev
Shock valve adjustment	225 bar
Pressure relief valve adjustment	170 bar

3.6 HYDRAULIC SYSTEM**HYDRAULIC PUMP****Pump 72 kW - 97 HP (580SR)**

Model	CASAPPA KP 30.34 - 05 S6 - LMF
Type	double gear pump: hydraulic system and priority steering system
Displacement	35.427 + 35.427 cm ³ /rev

Pump 82 kW - 110 HP (590SR / 695SR)

Model	CASAPPA KP 30.38 - 05 S6 - LMF
Type	double gear pump: hydraulic system and priority steering system
Displacement	40.258 + 35.427 cm ³ /rev

3.7 FRONT COUNTERWEIGHT

Weight	160 kg
--------------	--------



Suggest:

If the above button click is invalid.

Please download this document

first, and then click the above link

to download the complete manual.

Thank you so much for reading

3.8 NOISE AND VIBRATION LEVELS

NOISE LEVEL

Certified by the Manufacturer.

In compliance with European Directive 2000/14/EC - Stage II.

Internal noise level (LpA)	77 db
External noise level (LwA) (580SR)	102 db
External noise level (LwA) (590SR / 695SR)	103 db

VIBRATION LEVEL INSIDE THE CAB

Upper limbs	level lower than 2.5 m/s ²
Abdomen	level lower than 0.5 m/s ²

3.9 BUCKETS

LOADER BUCKETS

	Type	0.88 m ³ standard	1 m ³ standard	4x1	6x1 (with forks)
2WS	Heaped capacity	0.88 m ³	1.0 m ³	1.0 m ³	1.0 m ³
	Width	2,250 mm	2,250 mm	2,250 mm	2,250 mm
	Weight	310 kg	410 kg	800 kg	960 kg
4WS	Heaped capacity	-	1.15 m ³	1.15 m ³	1.15 m ³
	Width	-	2,400 mm	2,400 mm	2,400 mm
	Weight	-	426 kg	830 kg	990 kg

BACKHOE BUCKETS

Struck capacity SAE J 296	Width	Weight
76 l	305 mm	108 kg
109 l	457 mm	130 kg
153 l	610 mm	160 kg
196 l	762 mm	180 kg
238 l	914 mm	208 kg

<https://www.ebooklibonline.com>

Hello dear friend!

Thank you very much for reading.

Enter the link into your browser.

The full manual is available for immediate download.

<https://www.ebooklibonline.com>