

1. Trim along dashed line.
2. Slide into pocket on Binder Spine.

TYPE 1-4

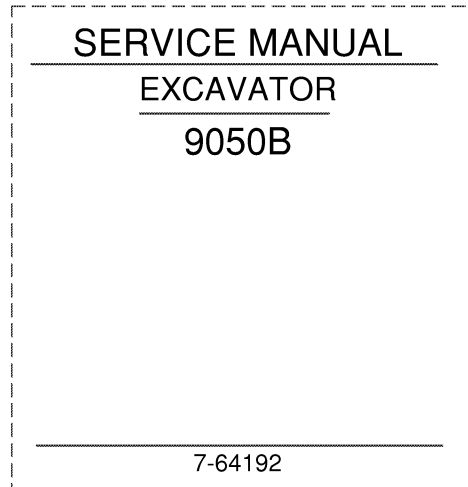

1. Trim along dashed line.
2. Slide into pocket on Binder Spine.

TYPE 1-4

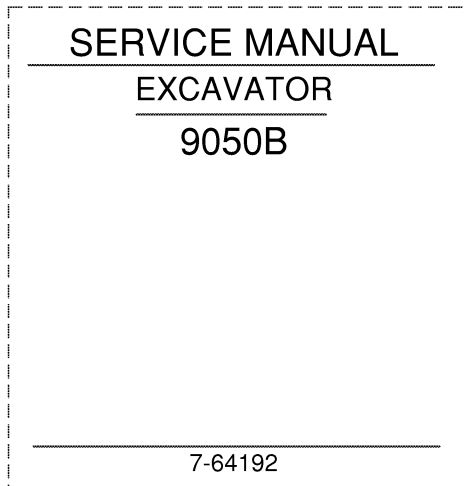

1. Trim along dashed line.
2. Slide into pocket on Binder Spine.

TYPE 1-4

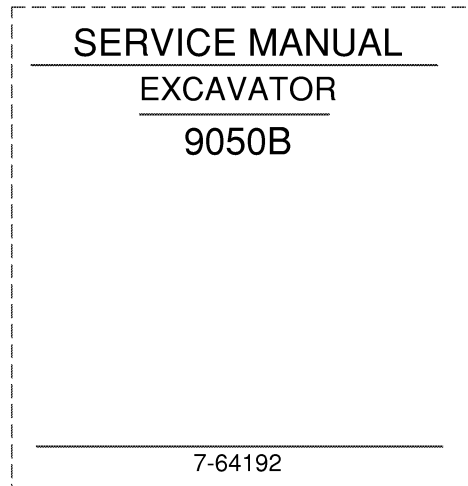

1. Trim along dashed line.
2. Slide into pocket on Binder Spine.

TYPE 1-4

9050B Excavator

Service Manual No. 7-64192

Table of Contents

Description	Section No.	Form No.
General	Tab 1	
Loctite Product Chart		8-98900
Safety, General Information and Torque Specifications	1001	7-62010
Specifications	1002	7-64280
Engines	Tab 2	
Engine	2000	7-64680
Radiator, Oil Cooler and Cooling System Reservoir	2001	7-64580
Fuel System	Tab 3	
Fuel Tank, Filters and Lines	3001	7-64490
Electrical	Tab 4	
Electrical Specifications and Troubleshooting	4001	7-63690
Electrical Schematic Foldout	In Rear Pocket	7-15340
Battery Testing, Maintenance and Booster Battery Connections	4002	7-64500
Controller	4003	7-62070
Tracks	Tab 5	
Tracks, Rollers and Idlers	5002	7-64560
Power Train	Tab 6	
Drive Motor and Final Drive Transmission	6002	7-64690
Swing Motor and Swing Reduction Gear	6003	7-64570
Hydraulics	Tab 8	
Cleaning the Hydraulic System	8000	7-64510
Hydraulic Specifications, Troubleshooting and Pressure Checks	8001	7-63700
Hydraulic Schematic Foldout	In Rear Pocket	7-15340
Main Hydraulic Pump	8002	7-64590
Main Hydraulic Control Valve	8003	7-64600
Cylinders	8004	7-64700
Hand Control Valves, Foot Left and Right Travel Control Valves, Shuttle Valve and Accumulator	8005	7-64520
Eight Spool Solenoid Valve, Swing Lock and Swing Brake Solenoid Valve	8006	7-64530
Cushion Control Valve	8007	7-64540
Auxiliary Hydraulics	8008	7-62180
Hydraulic Reservoir Pressurization System	8009	7-64710
Hydraulic Pilot Filter, Hydraulic Inline Filter and Bypass Oil Filter	8011	7-64550
Hydraulic Swivel	8013	7-64610

CASE CORPORATION
 700 State Street
 Racine, WI 53404 U.S.A.

CASE CANADA CORPORATION
 3350 South Service Road
 Burlington, ON L7N 3M6 CANADA

Reprinted

© 1999 Case Corporation
 Printed in U.S.A.
 April, 1999

Rac 7-52701

Description	Section No.	Form No.
Mounted Equipment	Tab 9	
Upper Structure and Counterweight	9002	7-64720
Boom, Arm and Bucket	9003	7-64730
Operators Seat, Operators Seat Bracket and Seat Belts	9004	7-62260
Cab and Cab Equipment	9005	7-62270
Air Conditioner Troubleshooting and System Checks	9006	7-62280
Air Conditioner Components Removal and Installation	9008	7-62300
Air Conditioner Components	9009	7-62310

<https://www.ebooklibonline.com>

Hello dear friend!

Thank you very much for reading.

Enter the link into your browser.

The full manual is available for immediate download.

<https://www.ebooklibonline.com>

Section 1001

**SAFETY, GENERAL INFORMATION
AND TORQUE SPECIFICATIONS**

SAFETY

 This symbol means **ATTENTION! BECOME ALERT! YOUR SAFETY IS INVOLVED.** The message that follows the symbol contains important information about safety. Carefully read the message. Make sure you fully understand the causes of possible injury or death. SB001

To prevent injury always follow the Warning, Caution and Danger notes in this section and throughout the manual.

Put the warning tag shown below on the key for the keyswitch when servicing or repairing the machine. One warning tag is supplied with each machine. Additional tags Part Number 331-4614 are available from your service parts supplier.

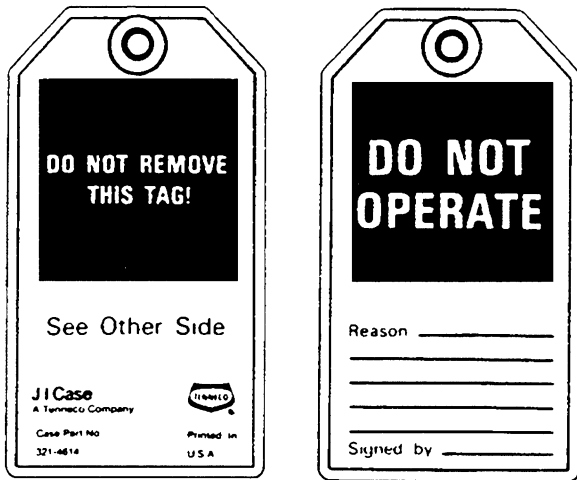



1001-01

 **WARNING:** Read the operator's manual to familiarize yourself with the correct control functions. 46-27

 **WARNING:** Operate the machine and equipment controls from the seat position only. Any other method could result in serious injury. 48-55

 **WARNING:** This is a one man machine, no riders allowed. 35-8

 **WARNING:** Before starting engine, study Operator's Manual safety messages. Read all safety signs on machine. Clear the area of other persons. Learn and practice safe use of controls before operating. It is your responsibility to understand and follow manufacturers instructions on machine operation, service and to observe pertinent laws and regulations. Operator's and Service Manuals may be obtained from your Case dealer. SA055

 **WARNING:** If you wear clothing that is too loose or do not use the correct safety equipment for your job, you can be injured. Always wear clothing that will not catch on objects. Extra safety equipment that can be required includes hard hat, safety shoes, ear protection, eye or face protection, heavy gloves and reflector clothing. 45-3A

 **WARNING:** When working in the area of the fan belt with the engine running, avoid loose clothing if possible, and use extreme caution. 35-4

 **WARNING:** When doing checks and tests on the equipment hydraulics, follow the procedures as they are written. **DO NOT** change the procedure. 47-44

 **WARNING:** When putting the hydraulic cylinders on this machine through the necessary cycles to check operation or to remove air from a circuit, make sure all people are out of the way. 47-45



WARNING: Use insulated gloves or mittens when working with hot parts. 47-41A



CAUTION: Lower all attachments to the ground or use stands to safely support the attachments before you do any maintenance or service. 49-11



CAUTION: Pin sized and smaller streams of hydraulic oil under pressure can penetrate the skin and result in serious infection. If hydraulic oil under pressure does penetrate the skin, seek medical treatment immediately. Maintain all hoses and tubes in good condition. Make sure all connections are tight. Make a replacement of any tube or hose that is damaged or thought to be damaged. **DO NOT** use your hand to check for leaks, use a piece of cardboard or wood. 40-6A



CAUTION: When removing hardened pins such as a pivot pin, or a hardened shaft, use a soft head (brass or bronze) hammer or use a driver made from brass or bronze and a steel head hammer. 46-17



CAUTION: When using a hammer to remove and install pivot pins or separate parts using compressed air or using a grinder, wear eye protection that completely encloses the eyes (approved goggles or other approved eye protectors). 46-13



CAUTION: Use suitable floor (service) jacks or chain hoist to raise wheels or tracks off the floor. Always block machine in place with suitable safety stands. 40-7A



CAUTION: When servicing or repairing the machine, keep the shop floor and operator's compartment and steps free of oil, water, grease, tools, etc. Use an oil absorbing material and/or shop cloths as required. Use safe practices at all times. 40-8



CAUTION: Some components of this machine are very heavy. Use suitable lifting equipment or additional help as instructed in this Service Manual. 40-10



DANGER: Engine exhaust fumes can cause death. If it is necessary to start the engine in a closed place, remove the exhaust fumes from the area with an exhaust pipe extension. Open the doors and get outside air into the area. 48-56



WARNING: When the battery electrolyte is frozen, the battery can explode if (1), you try to charge the battery, or (2), you try to jump start and run the engine. To prevent the battery electrolyte from freezing, try to keep the battery at full charge. If you do not follow these instructions, you or others in the area can be injured. SA033

GENERAL INFORMATION

CLEANING

Clean all metal parts except bearings, in a suitable cleaning solvent or by steam cleaning. Do not use caustic soda for steam cleaning. After cleaning, dry and put oil on all parts. Clean oil passages with compressed air. Clean bearings in a suitable cleaning solvent, dry the bearings completely and put oil on the bearings.

INSPECTION

Check all parts when the parts are disassembled. Replace all parts that have wear or damage. Small scoring or grooves can be removed with a hone or crocus cloth. Complete a visual inspection for indications of wear, pitting and the replacement of parts necessary to prevent early failures.

BEARINGS

Check bearings for easy action. If bearings have a loose fit or rough action replace the bearing. Wash bearings with a suitable cleaning solvent and permit to air dry. **DO NOT DRY BEARINGS WITH COMPRESSED AIR.**

NEEDLE BEARINGS

Before you press needle bearings in a bore always remove any metal protrusions in the bore or edge of the bore. Before you press bearings into position put petroleum jelly on the inside and outside diameter of the bearings.

GEARS

Check all gears for wear and damage. Replace gears that have wear or damage.

OIL SEALS, O-RINGS AND GASKETS

Always install new oil seals, O-rings and gaskets. Put petroleum jelly on seals and O-rings.

SHAFTS

Check all shafts that have wear or damage. Check the bearing and oil seal surfaces of the shafts for damage.

SERVICE PARTS

Always install genuine Case service parts. When ordering refer to the Parts Catalog for the correct part number of the genuine Case replacement items. Failures due to the use of other than genuine Case replacement parts are not covered by warranty.

LUBRICATION

Only use the oils and lubricants specified in the Operator's or Service Manuals. Failures due to the use of non-specified oils and lubricants are not covered by warranty.

STANDARD TORQUE DATA FOR CAP SCREWS AND NUTS

TIGHTENING OF CAP SCREWS, NUTS

Tighten alternately so that tightening torque can be applied evenly. The numbers in the figure below indicate the order of tightening.

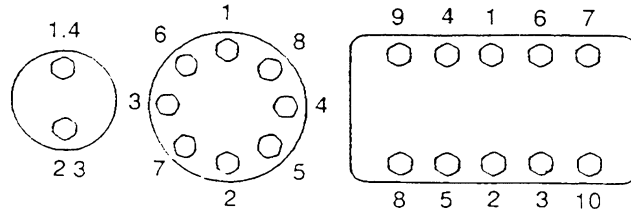

1001-02

Apply engine oil to the thread portion of the cap screw so that uniform tightening torque is obtained.

The cap screws and nuts that cannot be inspected externally or those as indicated in the assembly/installation sections should be safetied with lockwire, cotter pin or bent washer.

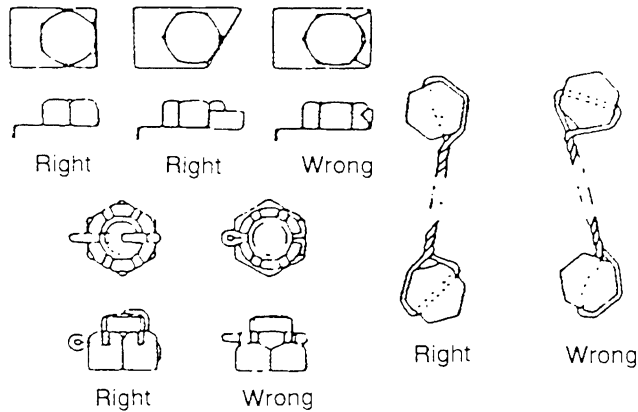

1001-03

Cap screws which have had Loctite used (white residue remains after removal) should be cleaned with light oil or suitable cleaning solvent and dried. Apply 2-3 drops of Loctite to the thread portion of the cap screw and then tighten.

TORQUE TABLE

Tighten cap screws and nuts according to the table below if there are no other special instructions.

Cap Screw Name Size (Size)			M6	M8	M10	M12	M14	M16	M18	M20
Cap Screw	Spanner	[mm]	10	13	17	19	22	24	27	30
		[in.]	0.39	0.51	0.67	0.75	0.87	0.95	1.06	1.18
	Tightening torque	[Nm]	6.9	15.7	32.3	58.8	98.0	137.2	196.0	274.0
		[lb-ft]	5.1	11.6	23.9	43.4	72.3	101.2	144.6	202.4
Socket Head Cap Screw	Spanner	[mm]	5	6	8	10	12	14	14	17
		[in.]	0.20	0.24	0.32	0.39	0.47	0.55	0.55	0.67
	Tightening torque	[Nm]	8.8	21.6	42.1	78.4	117.6	176.4	245.0	343.0
		[lb-ft]	6.5	15.9	31.1	57.8	86.8	130.1	180.8	253.1

MODEL AND PIN NUMBERS

When ordering parts or when requesting information or assistance, always give the identification numbers of your machine. Write the model and PIN numbers of your machine on the lines below.



A27416



A23983

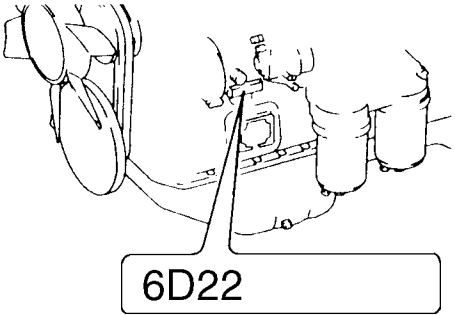

JS01443A

Machine Model Number _____

Machine PIN Number _____

Engine Serial Number _____

Section 2000

2000

ENGINE

ENGINE

Removal

NOTE: Make sure engine is cool before starting removal procedures.

STEP 1

Remove the hydraulic pump (see Section 8002).

STEP 2

Remove the radiator, oil cooler, and the cooling system reservoir (see Section 2001).

STEP 3

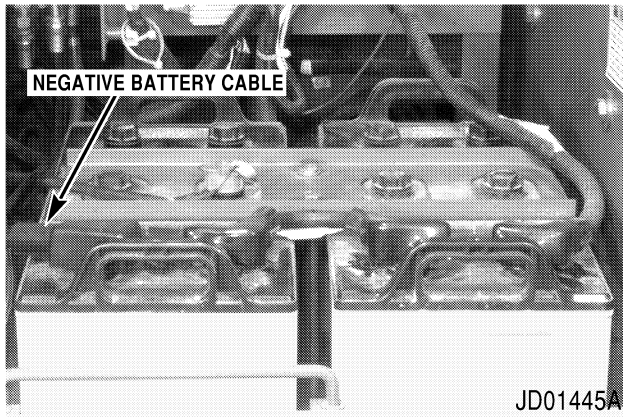

Open the left side access doors. Disconnect the negative battery cable from the battery.

STEP 4

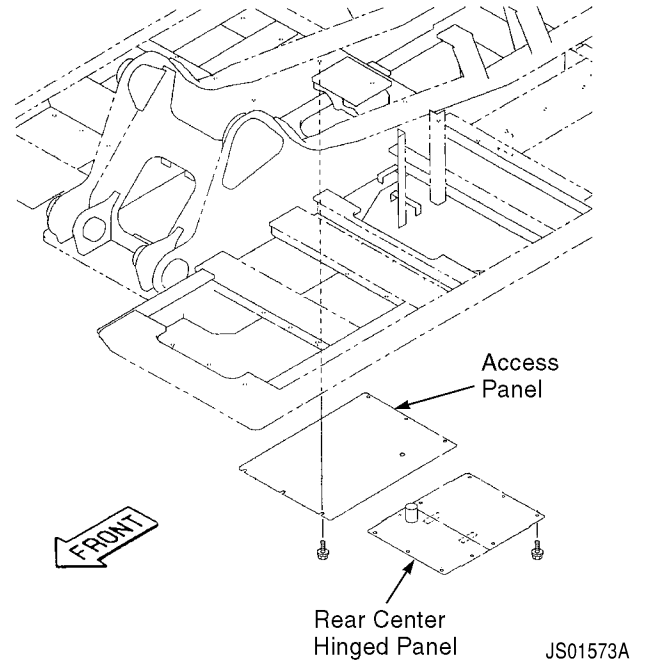

Remove the bottom right rear access panel. Remove the five cap screws securing the rear center hinged panel below the engine. Swing the panel down for access to the engine two left mounts.

STEP 5

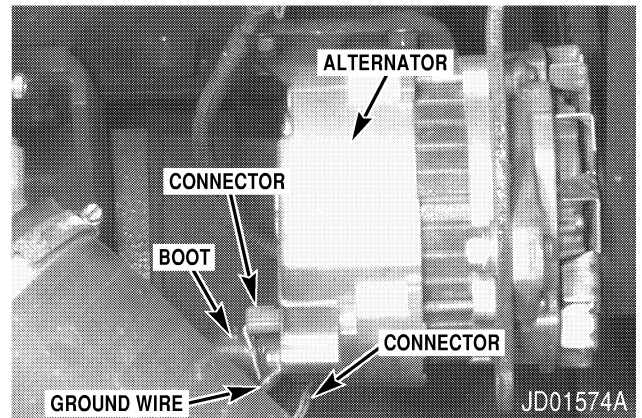

Tag and disconnect the two wiring harness connectors and the ground wire from the alternator. Pull the boot away from the alternator output terminal and tag and disconnect the wiring harness wire from the alternator. Cut, remove, and discard the tie strap securing the wiring harness to the alternator mounting bracket.

STEP 6

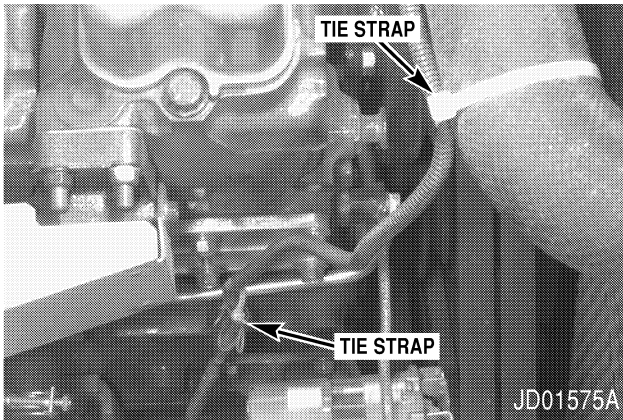

Cut, remove, and discard the two tie straps holding the wiring harness to the engine and the radiator hose.

STEP 7

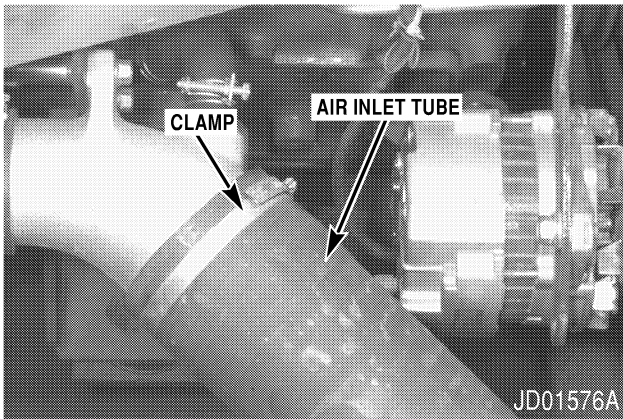

Loosen the clamp securing the air inlet tube to the turbocharger. Disconnect the air inlet tube.

STEP 8

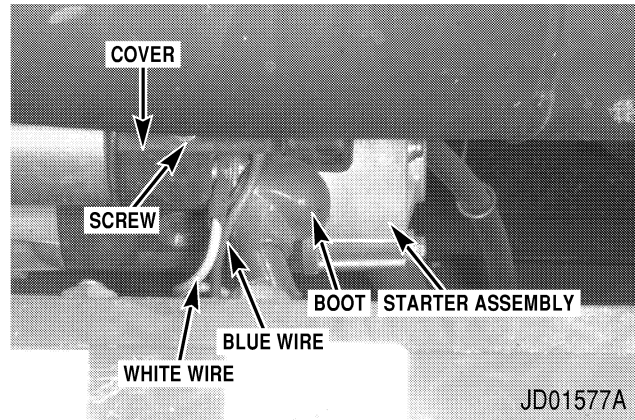

Remove the screw, flat washer, and lock washer and remove the cover. Tag and disconnect the wiring harness blue wire from the starter assembly terminal. Pull the boot away from the starter assembly terminal and down the cable. Tag and disconnect the wiring harness white wire and the cable from the starter assembly.

STEP 9

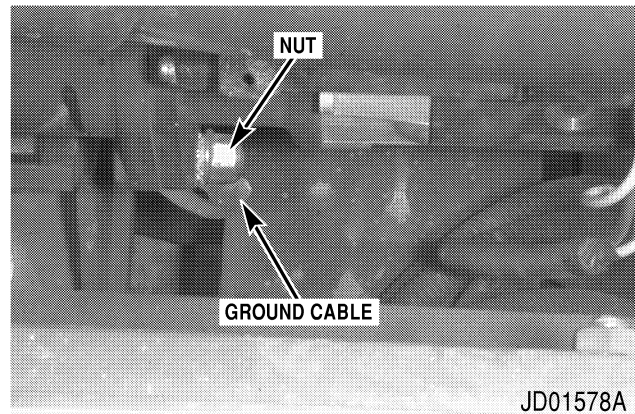

Remove the nut and lock washer. Disconnect the ground cable from the engine.

STEP 10

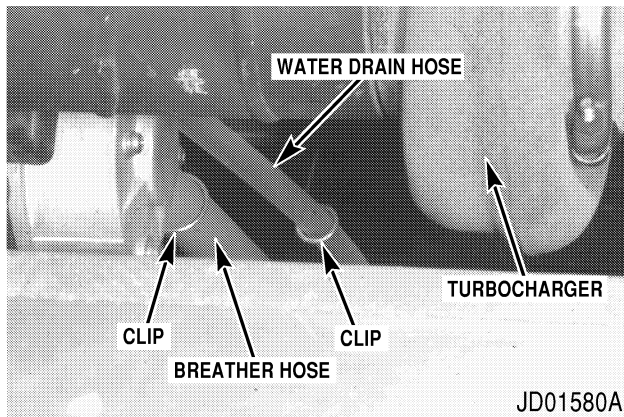
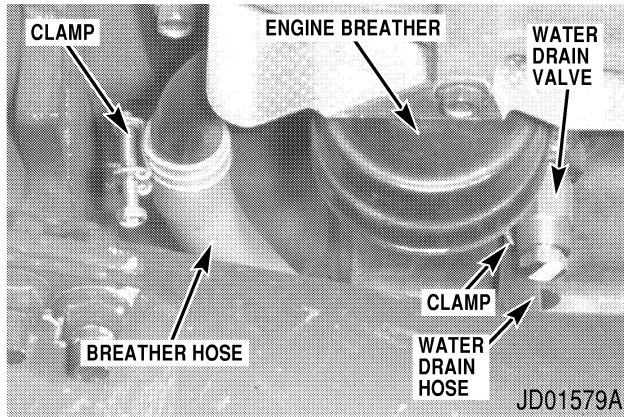

Loosen the clamp securing the breather hose and disconnect the breather hose. Using pliers, remove the clamp from the water drain hose connected to the water drain valve. Disconnect the water drain hose. Pull the hoses from the clips installed on the engine.

STEP 11

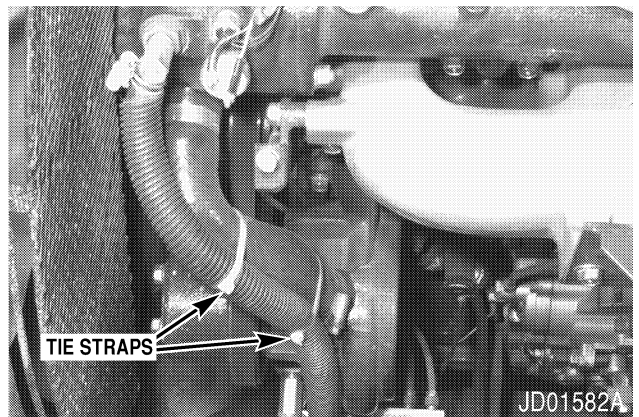
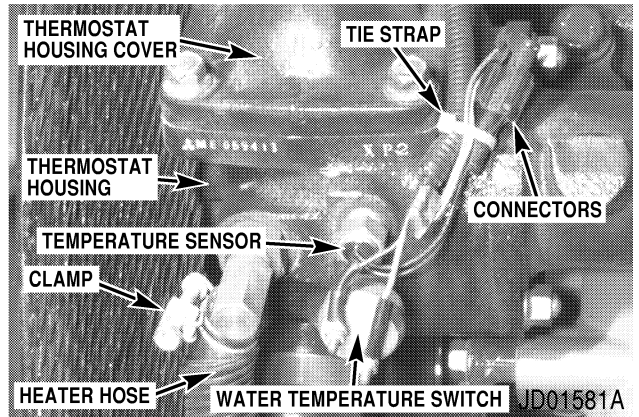

Cut, remove, and discard the tie strap. Disconnect the temperature sensor connector from the wiring harness connector. Tag and disconnect the wiring harness two wires from the water temperature switch. Loosen the clamp and disconnect the heater hose from the fitting installed in the thermostat housing. Cut, remove, and discard the two tie straps securing the heater hose.

STEP 12

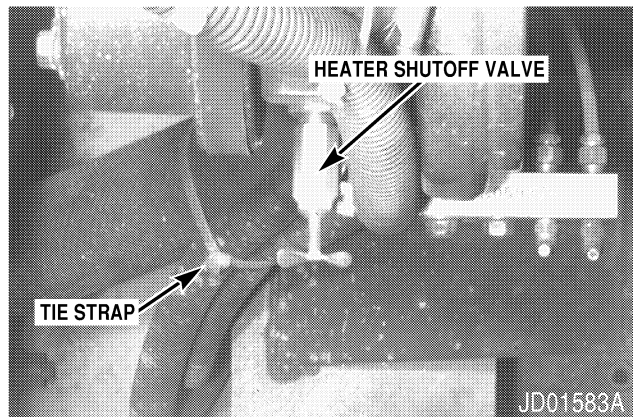

Loosen the clamp securing the heater hose to the heater shutoff valve. Disconnect the hose from the heater shutoff valve. Cut, remove, and discard the two tie straps securing the heater hoses.

STEP 13

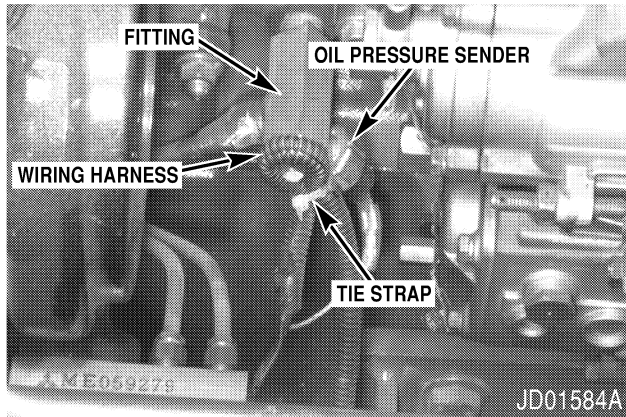

Tag and disconnect the wiring harness wire connected to the oil pressure sender. Cut, remove, and discard the tie strap. Pull the wiring harness from the oil pressure sender fitting.

STEP 14

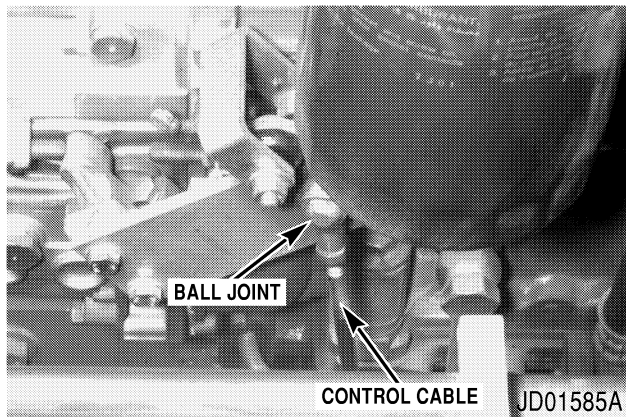

Remove the nut and lock washer securing the control cable ball joint to the fuel injection pump throttle bracket. Disconnect the ball joint.

STEP 15

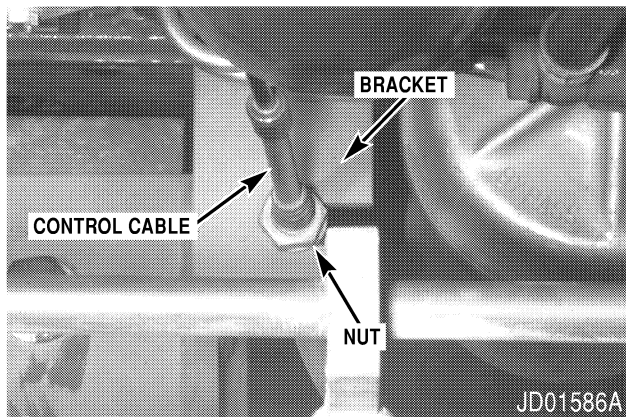

Loosen the two nuts securing the control cable to the bracket. Remove the control cable from the bracket.

STEP 16

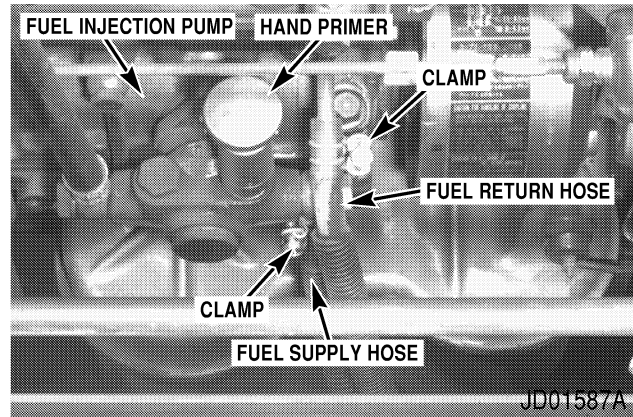

Tag the fuel supply hose and the fuel return hose. Loosen the two clamps and disconnect the hoses.

STEP 17

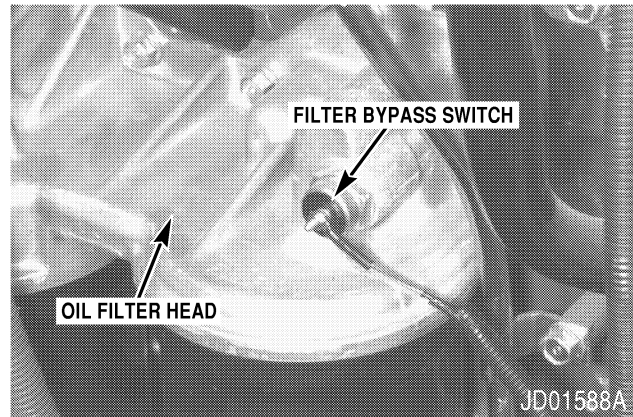

Tag and disconnect the wiring harness wire connected to the filter bypass switch.

STEP 18

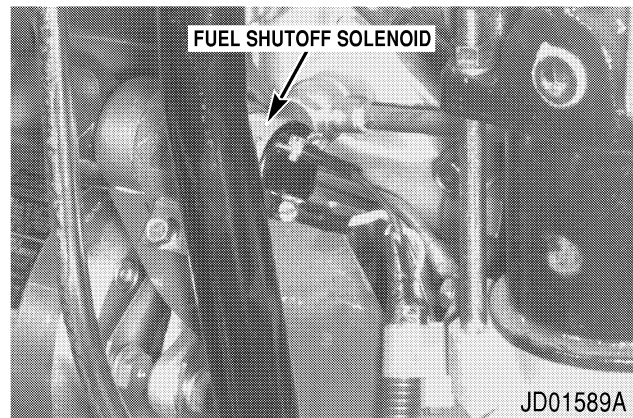

Tag and disconnect the wiring harness two wires connected to the fuel shutoff solenoid.

STEP 19

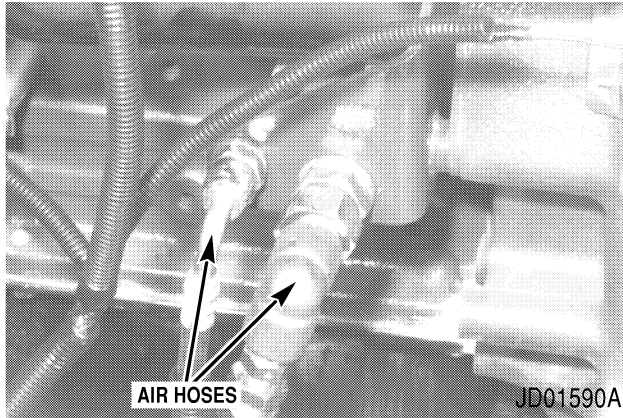

Tag and disconnect the two air hoses.

STEP 21

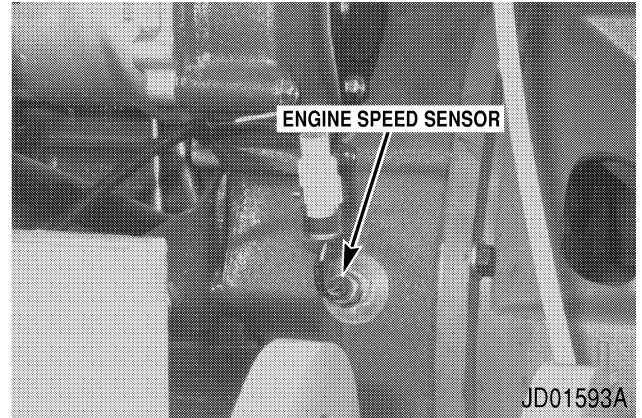

Disconnect the wiring harness connector from the engine speed sensor.

STEP 20

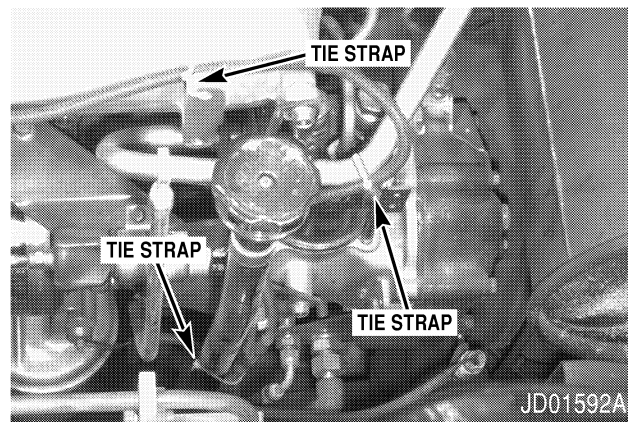
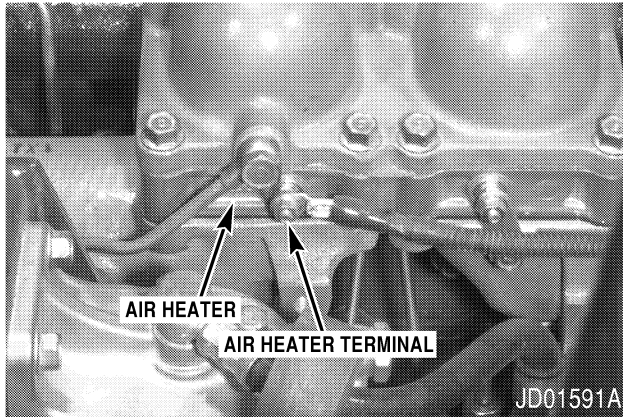

Tag and disconnect the wiring harness wire from the air heater terminal. Cut, remove, and discard the three tie straps securing the wiring harness wire to the engine.

STEP 22

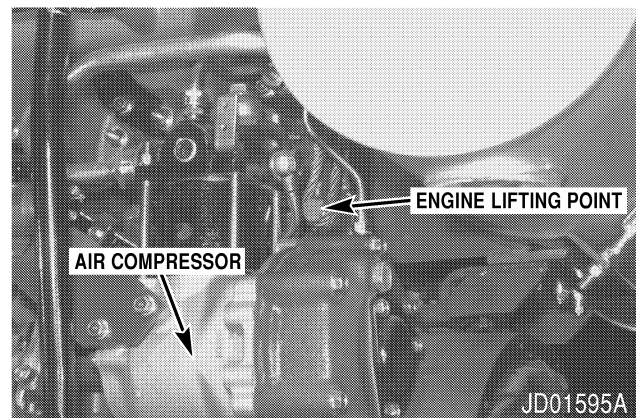
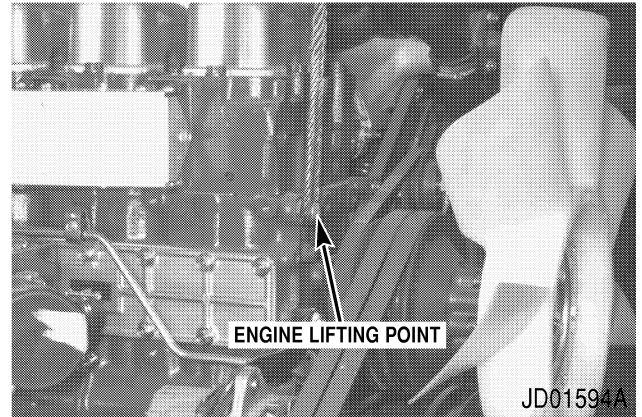

Connect suitable lifting equipment to the engine at the two lifting points. The weight of the engine is 2198 pounds (997 kg).

STEP 23

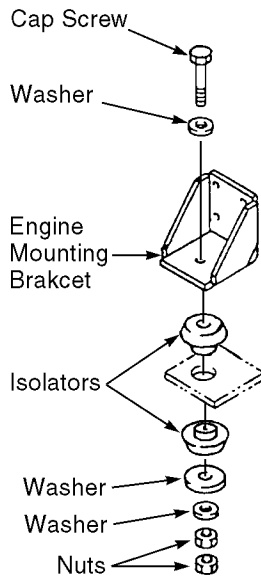
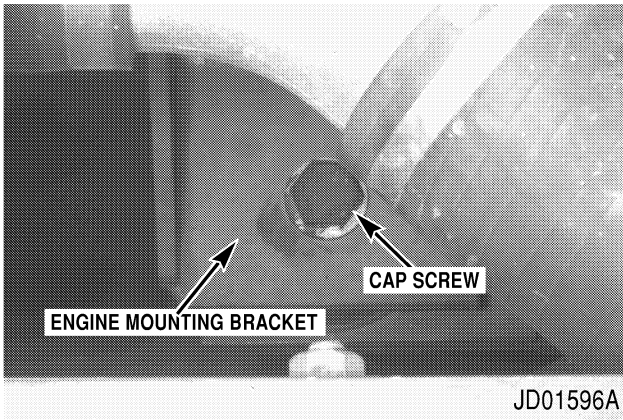

JS01597A

Remove the two nuts, three washers, rubber isolator, and cap screw. Repeat this step for the remaining three engine mounts.

STEP 24

NOTE: *When raising the engine from the machine check and make sure all wires and hoses have been disconnected and will not interfere with the removal of the engine.*

Raise the engine from the mounts. Move the engine rearward and away from the machine.

STEP 25

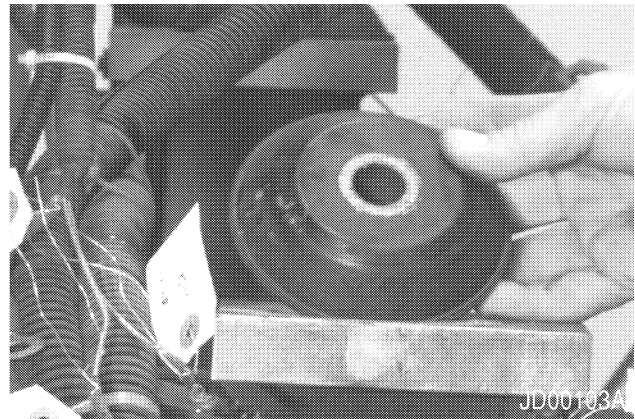
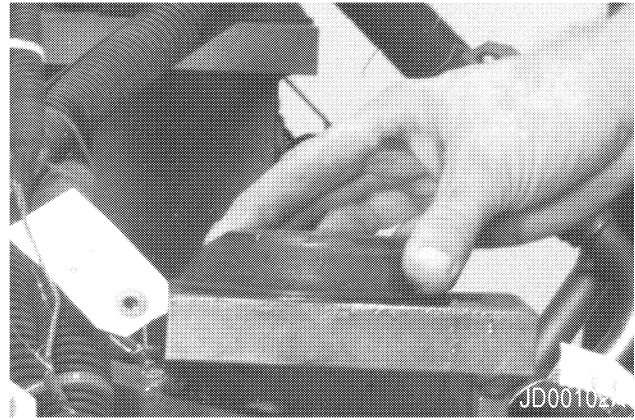

Remove the rubber engine isolators from the four engine mounts.

Installation

STEP 1

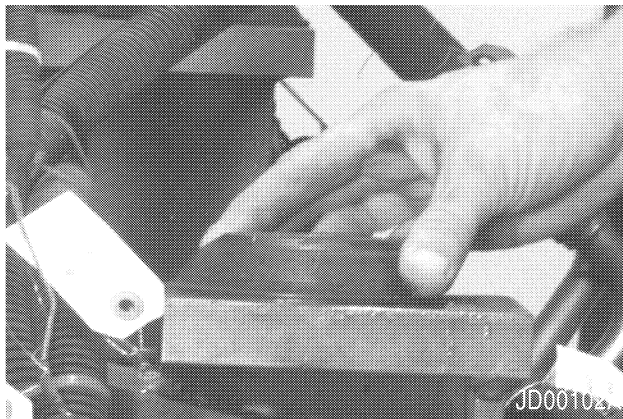
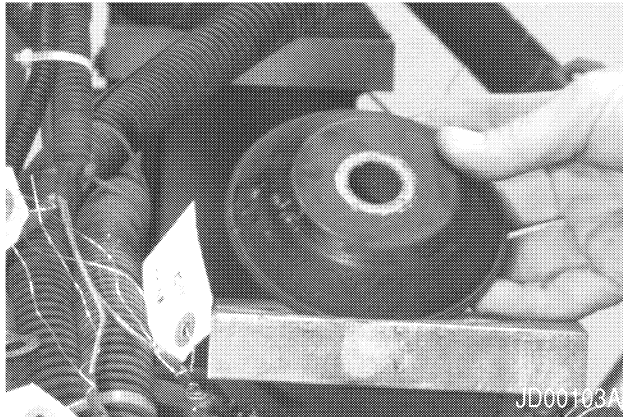

Inspect the rubber engine isolators for cracks, deterioration, or damage. Replace the isolators if cracked, deteriorated, or damaged. Install the rubber engine isolators on the four engine mounts.

STEP 2

Connect suitable lifting equipment to the engine. The weight of the engine is 2198 pounds (997 kg). Move the engine into position and lower onto the engine mounts.

STEP 3

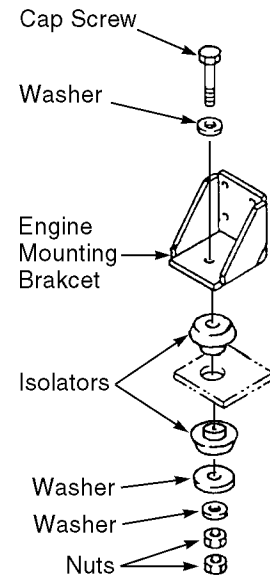
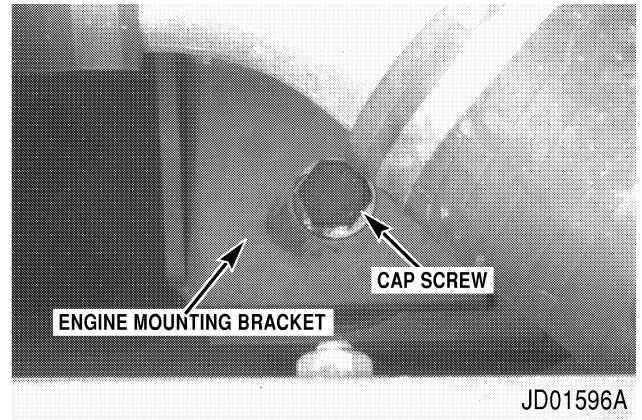

Apply Loctite 262 to the threads of the cap screw. Install the rubber isolator, cap screw, three washers, and one nut. Tighten the cap screw to 213 to 249 lb-ft (289 to 337 Nm). Install the second nut and tighten securely against the first nut. Repeat this step for the remaining three engine mounts.

STEP 4

Disconnect the lifting equipment from the engine lifting points.

STEP 5

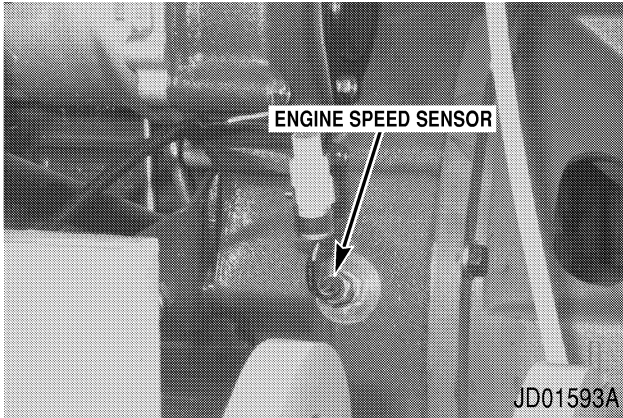

Connect the wiring harness connector to the engine speed sensor.

STEP 7

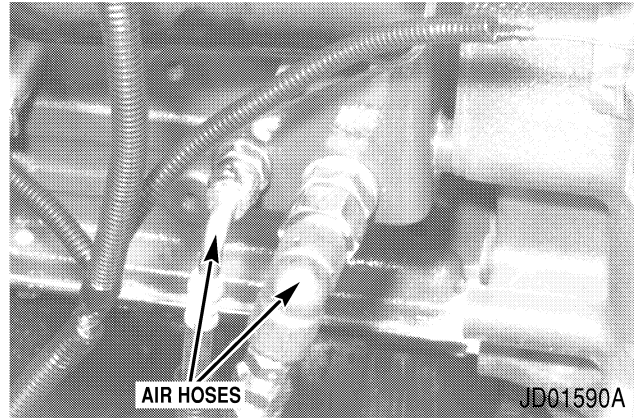

Connect the two air hoses following the tags installed during removal. Remove and discard the tags.

STEP 6

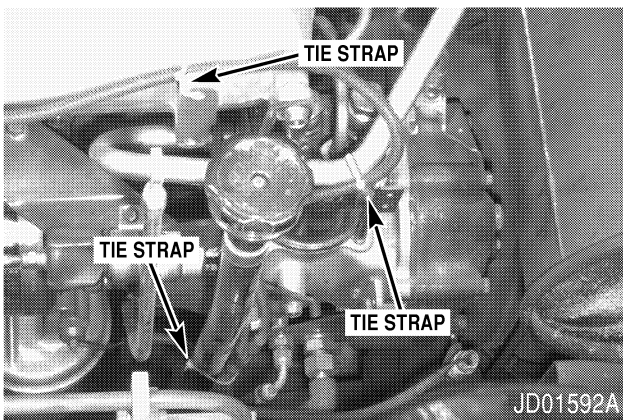
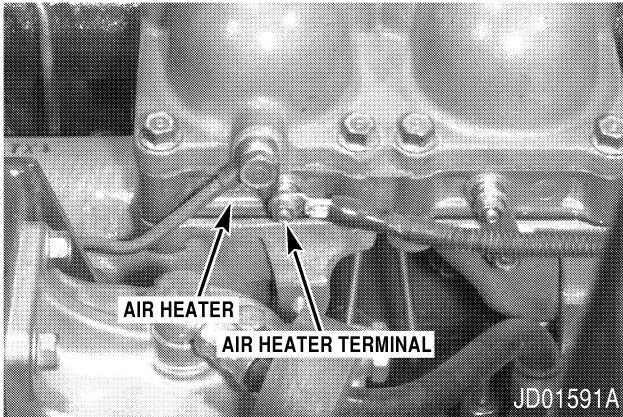

Route the wiring harness wire to the air heater. Connect the wiring harness wire to the air heater terminal following the tag installed during removal. Remove and discard the tag. Install three new tie straps to secure the wiring harness to the engine.

STEP 8

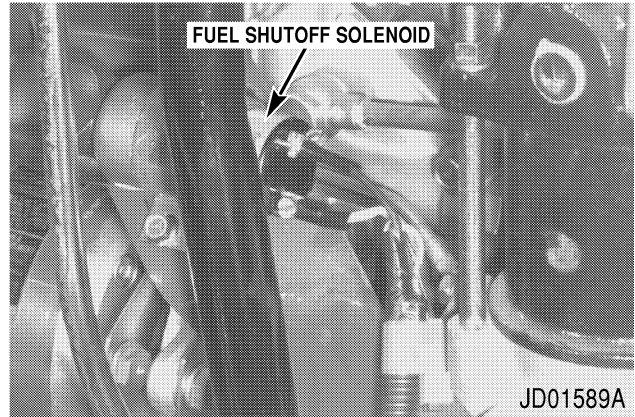

Connect the wiring harness two wires to the fuel shutoff solenoid following the tags installed during removal. Remove and discard the tags.

STEP 9

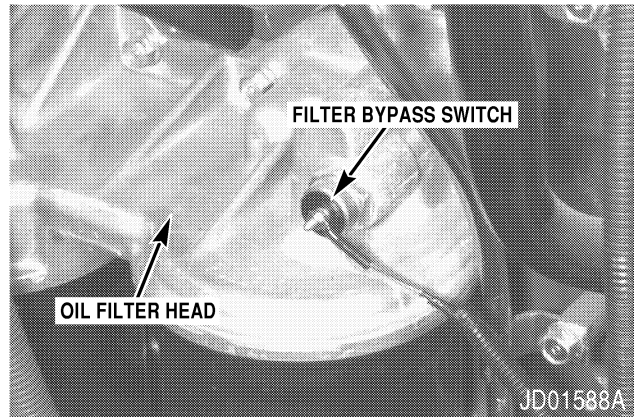

Connect the wiring harness wire to the filter bypass switch following the tag installed during removal. Remove and discard the tag.

STEP 10

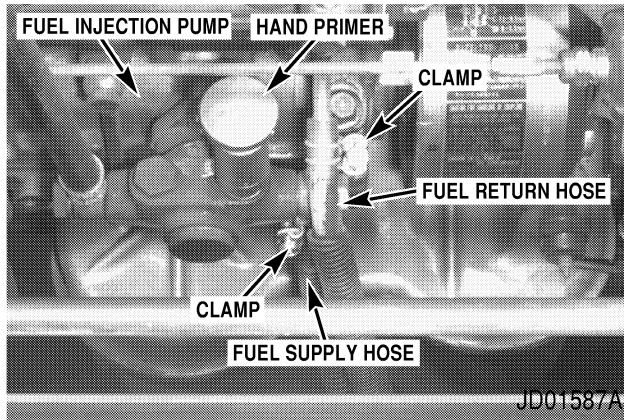

Install a clamp on the fuel return hose and the fuel supply hose. Connect the fuel return hose and the fuel supply hose to the fittings following the tags installed during removal. Position the clamps on the hoses and tighten the clamps to secure the hoses. Remove and discard the tags.

STEP 11

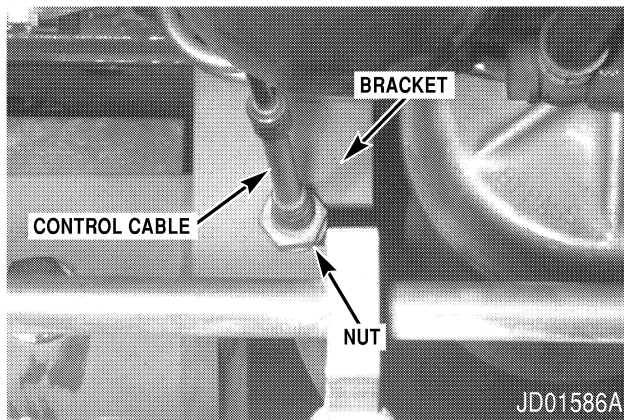

Install the control cable on the bracket and tighten the two nuts to secure the control cable.

STEP 12

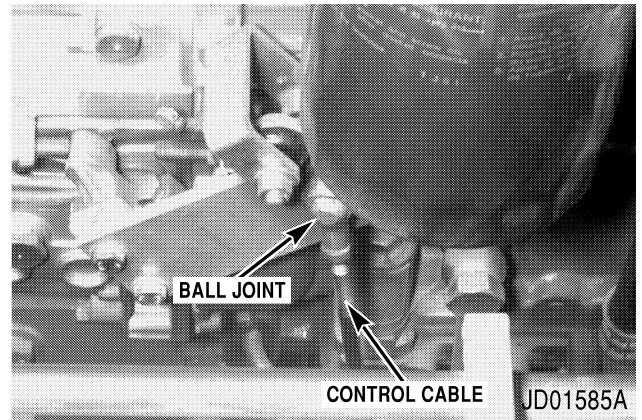

Connect the control cable ball joint to the fuel injection pump throttle bracket. Install the lock washer and nut to secure the ball joint.

STEP 13

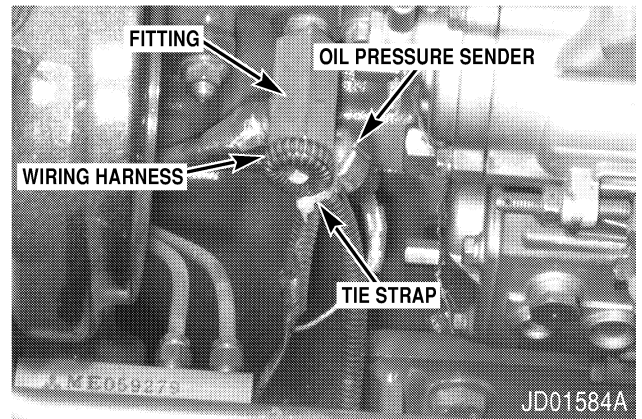

Connect the wiring harness wire to the oil pressure sender following the tag installed during removal. Position the wiring harness on the end of the oil pressure sender fitting and secure using a new tie strap. Remove and discard the tag.

STEP 14

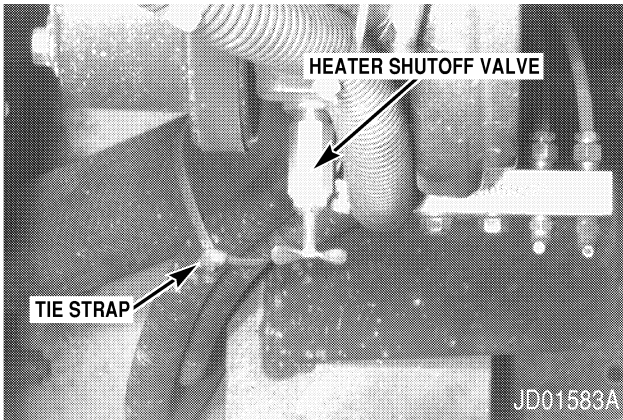

Install the clamp on the heater hose. Connect the hose to the heater shutoff valve and tighten the clamp to secure the hose. Install two new tie straps to secure the heater hoses.

STEP 15

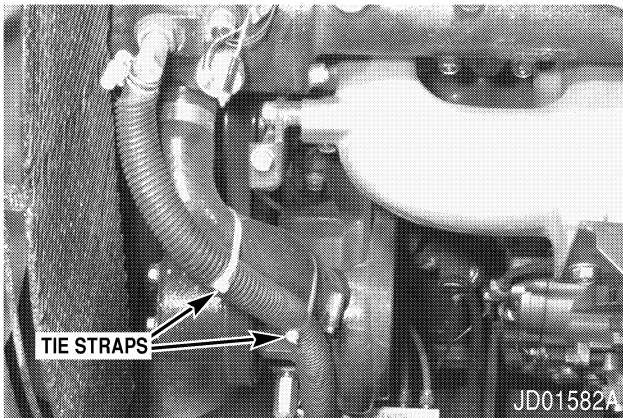
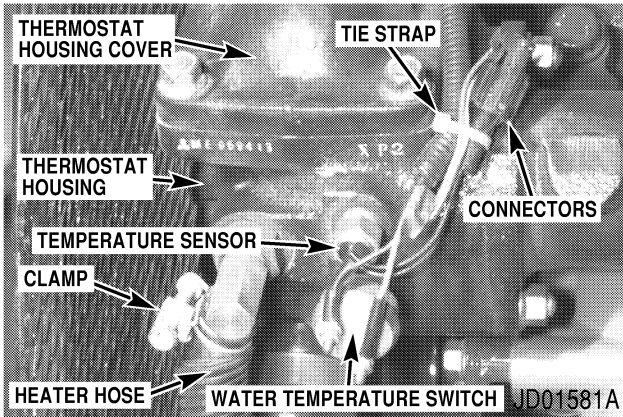

Install the clamp on the heater hose. Connect the heater hose to the fitting installed in the thermostat housing. Tighten the clamp to secure the heater hose. Connect the wiring harness two wires to the water temperature switch following the tags installed during removal. Connect the temperature sensor connector to the wiring harness connector. Install a new tie strap to secure the connectors to the wiring harness. Install two new tie straps to secure the heater hose.

STEP 16

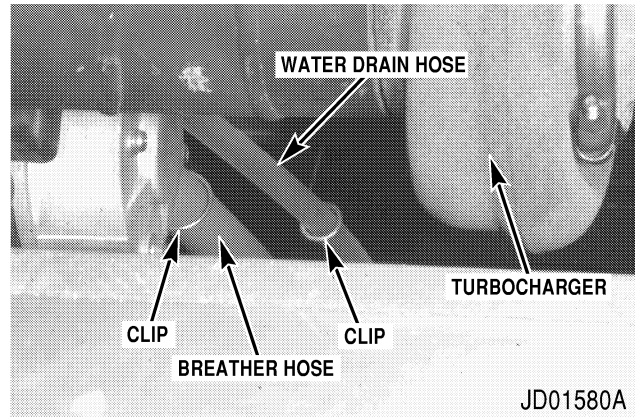
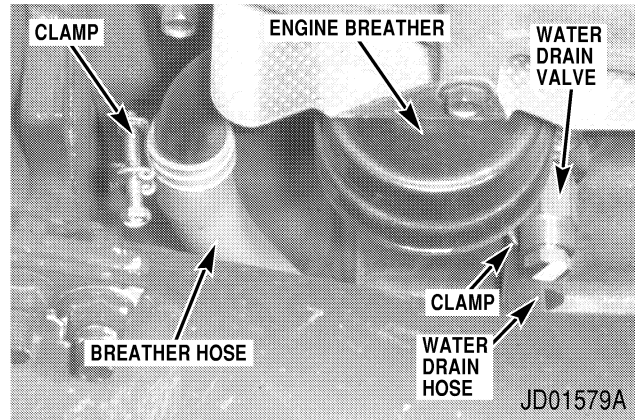

Route the water drain hose and the breather hose through the clips installed in the engine. Using pliers, install the clamp on the water drain hose and connect the water drain hose to the water drain valve. Install the clamp on the breather hose. Connect the breather hose and tighten the clamp.

STEP 17

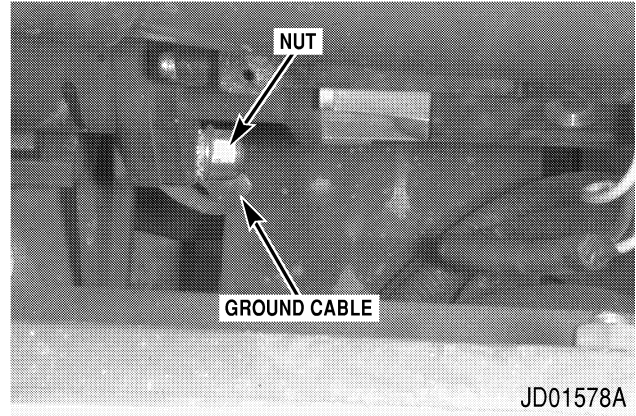

Connect the ground cable to the engine flywheel housing and install the lock washer and nut.

STEP 18

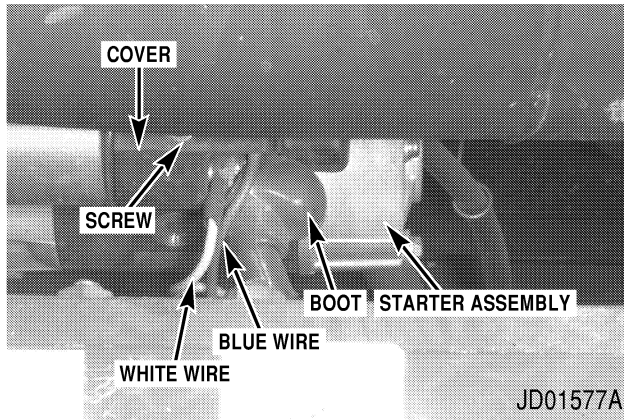

Connect the wiring harness white wire and the cable to the large terminal of the starter assembly following the tags installed during removal. Push the boot up on the cable and over the starter assembly terminal. Connect the wiring harness blue wire to the starter assembly following the tag installed during removal. Install the cover on the starter assembly and secure using the flat washer, lock washer, and screw. Remove the tags from the wiring harness wires and cable and discard the tags.

STEP 19

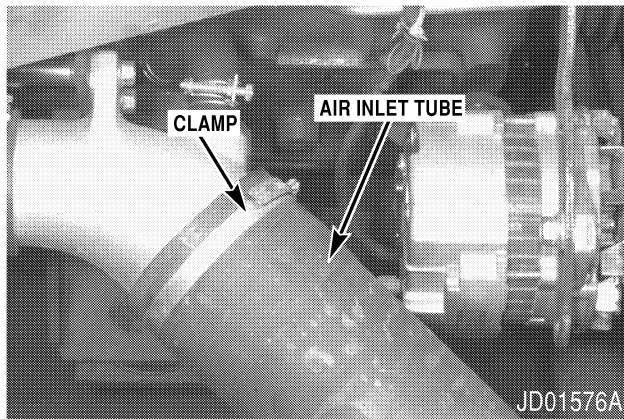

Connect the air inlet tube to the turbocharger. Tighten the clamp to secure the tube.

STEP 20

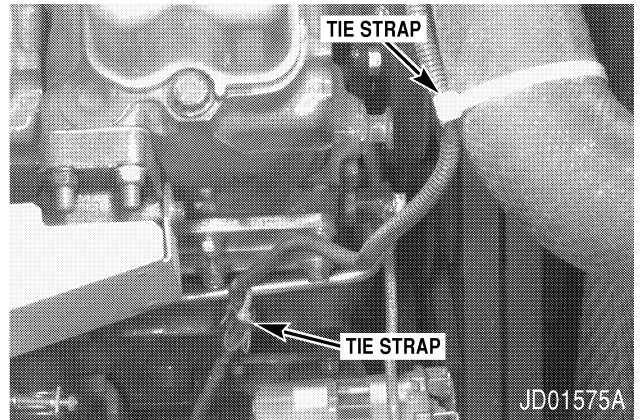

Install two new tie straps to secure the wiring harness to the radiator hose and the engine.

STEP 21

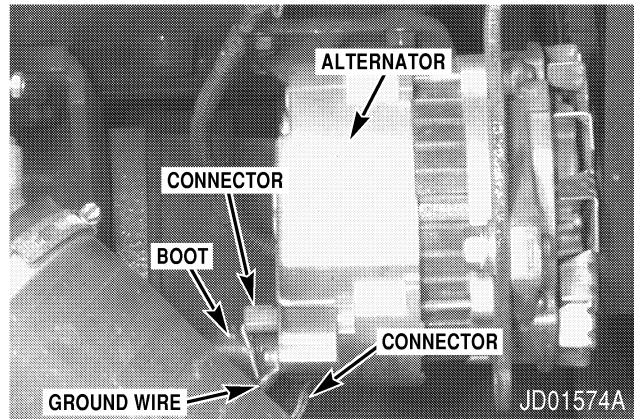

Connect the wiring harness wire to the alternator output terminal following the tag installed during removal. Push the boot over the output terminal. Connect the wiring harness ground wire and the two connectors to the alternator following the tags installed during removal. Secure the wiring harness to the alternator mounting bracket using a new tie strap. Remove and discard the tags.



Suggest:

If the above button click is invalid.

Please download this document

first, and then click the above link

to download the complete manual.

Thank you so much for reading

STEP 22

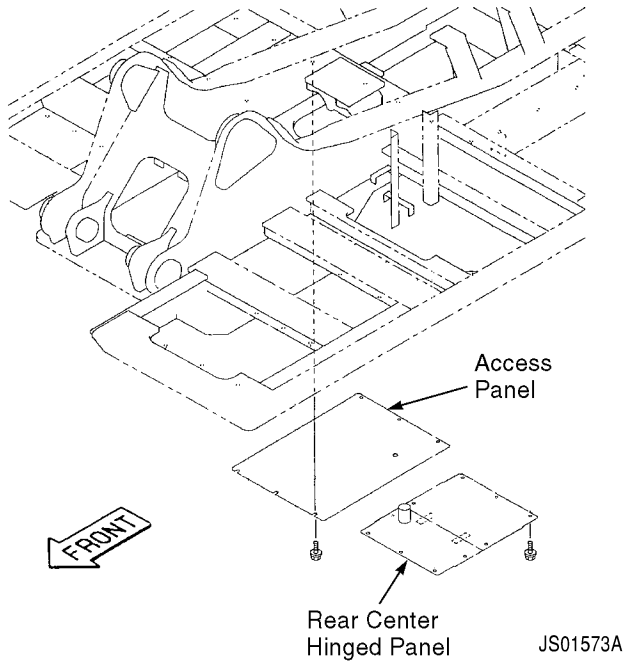

Swing the rear center hinged panel below the engine up. Secure the hinged panel using five cap screws. Install the bottom right rear access panel.

STEP 23

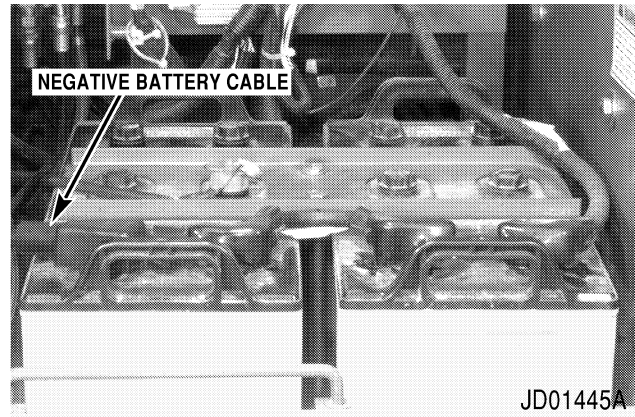

Connect the negative battery cable to the battery.

STEP 24

Install the radiator, oil cooler, and the cooling system reservoir. Service the radiator coolant. (See Section 2001.)

STEP 25

Install the hydraulic pump. (See Section 8002.)

<https://www.ebooklibonline.com>

Hello dear friend!

Thank you very much for reading.

Enter the link into your browser.

The full manual is available for immediate download.

<https://www.ebooklibonline.com>