



Service Repair Manual

Models

311D LRR Excavator

[Previous Screen](#)

Product: EXCAVATOR

Model: 311D LRR EXCAVATOR DWR

Configuration: 311D LRR Excavator DWR00001-UP (MACHINE) POWERED BY C4.2 Engine

Disassembly and Assembly C4.2 Engine for Caterpillar Built Machines

Media Number -KENR8105-04

Publication Date -01/06/2013

Date Updated -12/06/2013

i02510046

Pistons and Connecting Rods - Install

SMCS - 1225-012

Installation Procedure

Table 1

| Required Tools | | | |
|----------------|-------------|------------------------|-----|
| Tool | Part Number | Part Description | Qty |
| A | 1U-6684 | Piston Ring Compressor | 1 |
| B | 6V-9120 | Socket ⁽¹⁾ | 1 |

⁽¹⁾ Tool (B) is a 46 mm socket.

NOTICE

Keep all parts clean from contaminants.

Contaminants may cause rapid wear and shortened component life.

Note: Refer to Disassembly and Assembly, "Connecting Rod Bearings - Install" for the inspection procedure of the connecting rod bearings and the crankshaft connecting rod journals.

1. Put clean engine oil on the crankshaft journals and on the inside of the cylinder bores. Put clean engine oil on the piston rings and the connecting rod bearings.
 2. Use Tooling (B) to rotate the crankshaft until the bearing journals are at the bottom center. The bearing journals that are at the bottom center are for the piston installation.
-

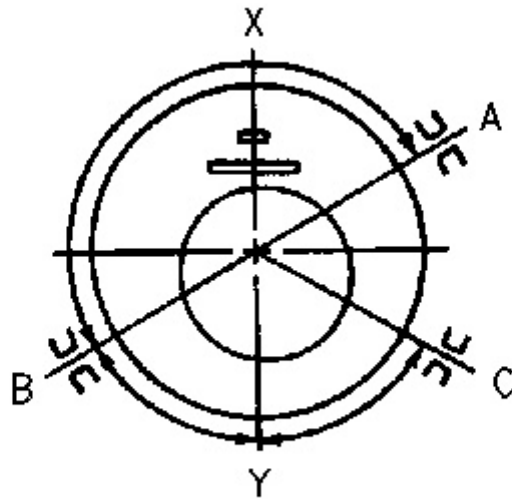

Illustration 1

g00524492

- (A) End gap for No. 1 ring (top compression ring)
- (B) End gap for No. 2 ring (intermediate compression ring)
- (C) End gap for oil control ring
- (X) Camshaft side of engine block
- (Y) Side of engine with combustion chamber

3. Move the piston rings on the pistons until the ring openings are separated by approximately 120 degrees.

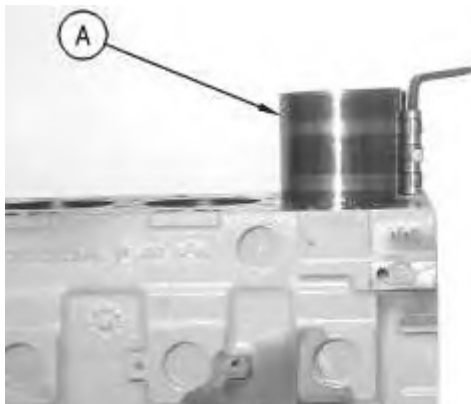

Illustration 2

g00534944

4. Put the piston in the cylinder liner. Align the identification marks on the top of the piston to the camshaft side of the cylinder block. Put Tooling (A) in position on the cylinder block and compress the piston rings.
5. Align the piston and connecting rod with the crankshaft. Use a soft faced hammer to tap the piston into the cylinder bore until Tool (A) comes off the piston.

Note: Ensure that Tooling (A) is installed correctly in order to allow the piston and the connecting rod to easily slip into the cylinder block.

<https://www.ebooklibonline.com>

Hello dear friend!

Thank you very much for reading.

Enter the link into your browser.

The full manual is available for immediate download.

<https://www.ebooklibonline.com>

Note: Use tape or rubber tubing on connecting rod bolts to protect the crankshaft journals. The sharp edges of the connecting rod bolts could damage the surface of the connecting rod journal.

6. Before the connecting rod contacts the crankshaft, install the rod bearing upper half in the respective connecting rod. Make sure that the bearing tab properly engages with the slot in the connecting rod.
7. Place clean engine oil on the surface of the upper half of the connecting rod bearing. Guide the connecting rod into position on the crankshaft.
8. Install the lower half of the connecting rod bearing in the correspondingly marked connecting rod cap. Put clean engine oil on the surface of the lower half of the connecting rod bearing and on the connecting rod bolts.

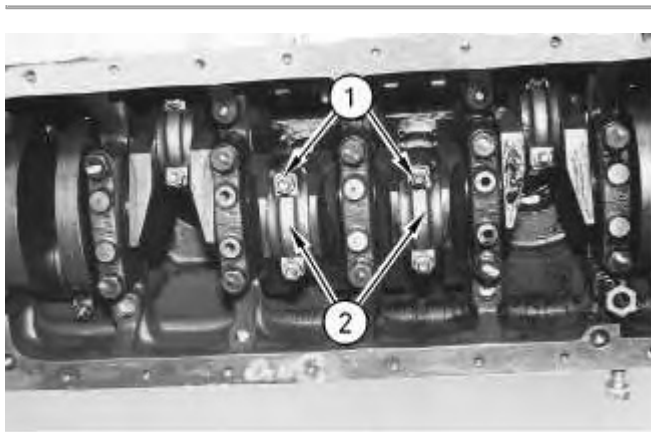

Illustration 3

g00534937

9. Install connecting rod cap (2) and connecting rod nuts (1). Tighten both of the nuts to a torque of $103 \pm 5 \text{ N}\cdot\text{m}$ ($76 \pm 4 \text{ lb ft}$).
10. Repeat Steps 1 through 9 for the remainder of the piston and connecting rods.

End By:

- a. Install the oil supply tube. Refer to Disassembly and Assembly, "Crankshaft - Install".
- b. Install the engine oil pan. Refer to Disassembly and Assembly, "Engine Oil Pan - Remove and Install".
- c. Install the cylinder head. Refer to Disassembly and Assembly, "Cylinder Head - Install".

Previous Screen

Product: EXCAVATOR

Model: 311D LRR EXCAVATOR DWR

Configuration: 311D LRR Excavator DWR00001-UP (MACHINE) POWERED BY C4.2 Engine

Disassembly and Assembly C4.2 Engine for Caterpillar Built Machines

Media Number -KENR8105-04

Publication Date -01/06/2013

Date Updated -12/06/2013

i01650751

Connecting Rod Bearings - Remove

SMCS - 1219-011

Removal Procedure

Table 1

| Required Tools | | | |
|----------------|-------------|-----------------------|-----|
| Tool | Part Number | Part Description | Qty |
| A | 6V-9120 | Socket ⁽¹⁾ | 1 |

⁽¹⁾ Tool (A) is a 46 mm socket.

Start By:

- a. Remove the engine oil pan. Refer to Disassembly and Assembly, "Engine Oil Pan - Remove and Install".
- b. Remove the oil supply tube. Refer to Disassembly and Assembly, "Crankshaft - Remove".

NOTICE

Keep all parts clean from contaminants.

Contaminants may cause rapid wear and shortened component life.

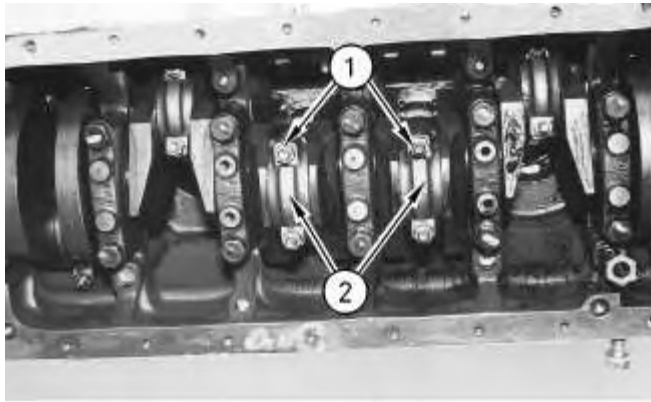

Illustration 1

g00534937

1. Use Tool (A) to rotate the crankshaft until two of the pistons are at the bottom center. Remove connecting rod nuts (1) from the connecting rod. Remove connecting rod cap (2) for one connecting rod.
2. Remove the lower half of the connecting rod bearing from connecting rod cap (2).
3. Remove the upper half of the connecting rod bearing from the connecting rod. Push the connecting rod away from the crankshaft, if necessary.

Note: Use tape or rubber tubing on connecting rod bolts to protect the crankshaft journals. The sharp edges of the connecting rod bolts could damage the crankshaft journals.

Note: Ensure that identification marks are on the connecting rod, the connecting rod cap and the connecting rod bearing. The identification marks must be on the bearing tab side for installation purposes.

4. Repeat Steps 1 through 3 for the remaining connecting rod bearings.

[Previous Screen](#)

Product: EXCAVATOR

Model: 311D LRR EXCAVATOR DWR

Configuration: 311D LRR Excavator DWR00001-UP (MACHINE) POWERED BY C4.2 Engine

Disassembly and Assembly C4.2 Engine for Caterpillar Built Machines

Media Number -KENR8105-04

Publication Date -01/06/2013

Date Updated -12/06/2013

i01576846

Connecting Rod Bearings - Install

SMCS - 1219-012

Installation Procedure

Table 1

| Required Tools | | | |
|----------------|-------------|-----------------------|-----|
| Tool | Part Number | Part Description | Qty |
| A | 6V-9120 | Socket ⁽¹⁾ | 1 |

⁽¹⁾ Tool (A) is a 46 mm socket.

NOTICE

Keep all parts clean from contaminants.

Contaminants may cause rapid wear and shortened component life.

NOTICE

When the connecting rod caps are installed, ensure that the identification marks are aligned.

Note: Refer to Specifications, "Connecting Rod Bearing Journal" for information on bearing clearance checks.

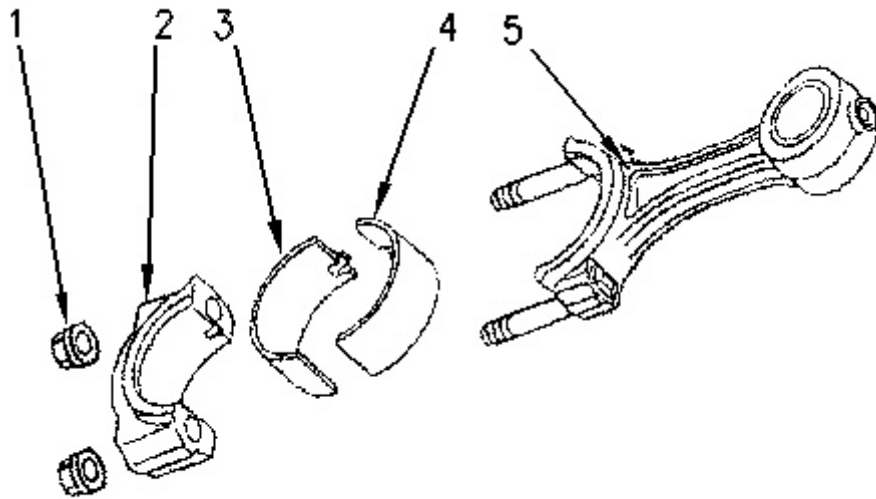

Illustration 1

g00586406

1. Clean the bearing surface of connecting rod (5) and connecting rod cap (2). Ensure that the number on connecting rod cap (2) matches the number on connecting rod (5).
2. Clean upper connecting rod bearing (4) and lubricate the bearing face with clean engine oil.
3. Clean lower connecting rod bearing (3) and lubricate the bearing face with clean engine oil.

Note: Align the tabs on the back of the connecting rod bearings with the tab grooves in the connecting rod.

4. Use Tool (A) to rotate the crankshaft until two of the connecting rod journals are at the bottom center. Install upper connecting rod bearing (4) in connecting rod (5).
5. Pull connecting rod (5) into position against the crankshaft.
6. Install lower connecting rod bearing (3) in connecting rod cap (2).
7. Put clean engine oil on the connecting rod bolts.

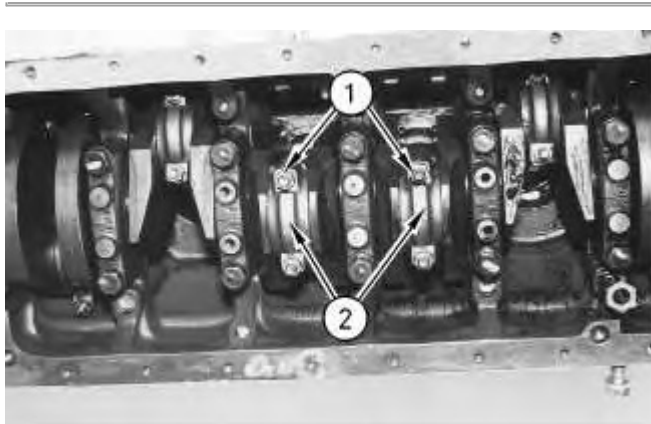

Illustration 2

g00534937

8. Install two nuts (1) on connecting rod cap (2). Tighten the connecting rod nuts to a torque of $103 \pm 5 \text{ N}\cdot\text{m}$ ($76 \pm 4 \text{ lb ft}$).
9. Repeat Steps 1 through 8 for the installation of the remaining connecting rod bearings.

End By:

- a. Install the oil supply tube. Refer to Disassembly and Assembly, "Crankshaft - Install".
- b. Install the engine oil pan. Refer to Disassembly and Assembly, "Engine Oil Pan - Remove and Install".

[Previous Screen](#)

Product: EXCAVATOR

Model: 311D LRR EXCAVATOR DWR

Configuration: 311D LRR Excavator DWR00001-UP (MACHINE) POWERED BY C4.2 Engine

Disassembly and Assembly C4.2 Engine for Caterpillar Built Machines

Media Number -KENR8105-04

Publication Date -01/06/2013

Date Updated -12/06/2013

i03706861

Crankshaft Main Bearings - Remove and Install

SMCS - 1203-010

Removal Procedure

Start By:

- A. Remove the crankshaft. Refer to Disassembly and Assembly, "Crankshaft - Remove".

NOTICE

Keep all parts clean from contaminants.

Contaminants may cause rapid wear and shortened component life.



Illustration 1

g00602470

1. Remove crankshaft main bearings (1) (upper shell) from the main bearing housing of the engine cylinder block.
2. Remove thrust washers (2) from the cylinder block and from the rear main cap.

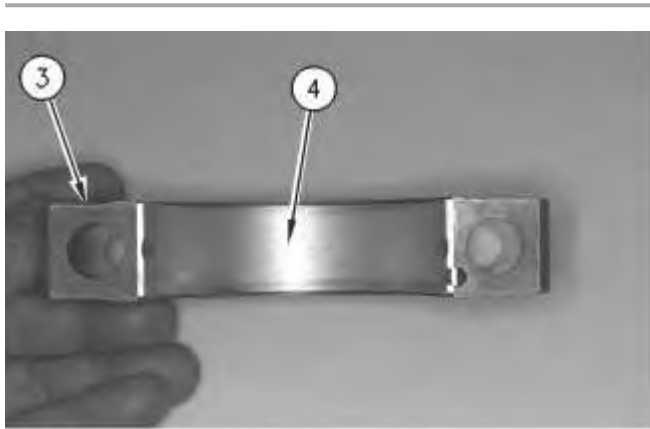

Illustration 2

g00602678

3. Remove the lower halves of the crankshaft main bearings (4) from the main bearing cap (3).

Note: Be careful not to damage the bearings. Mark each main bearing in order to ensure installation in the original location.

Note: Check the condition of the crankshaft main bearings. Refer to the Guideline For Reusable Parts, SEBF8009, "Main and Connecting Rod Bearings" or refer to the Guideline For Reusable Parts, SEBV0544, "Engine Bearings and Crankshafts".

Note: Refer to the Specifications Module, "Main Bearing Journal" for more information on crankshaft main bearings and the main bearing journals.

Installation Procedure

NOTICE

Keep all parts clean from contaminants.

Contaminants may cause rapid wear and shortened component life.

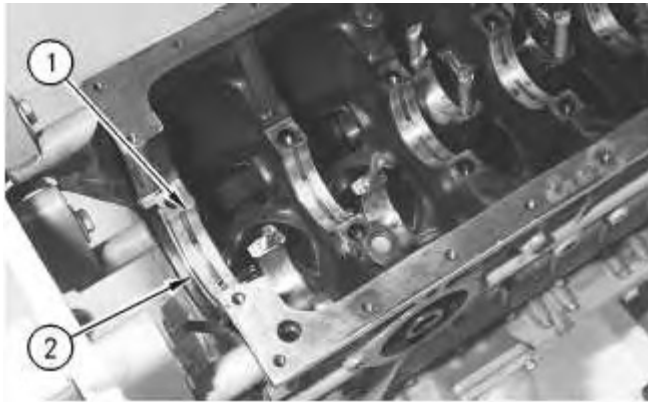

Illustration 3

g00602470

1. Install the upper halves of the crankshaft main bearings (1) in the main bearing housing of the cylinder block.

Note: Ensure that the main bearing tab fits in the tab groove of the bearing housing of the cylinder block.

2. Install thrust washers (2) into the cylinder block and the rear main cap.

Note: Install the thrust washers with the oil grooves toward the outside.

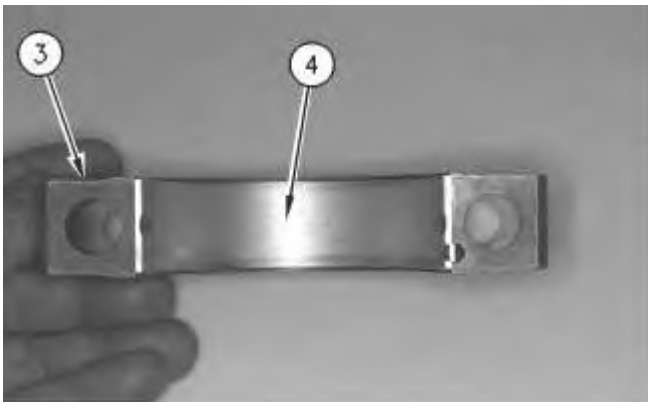

Illustration 4

g00602678

3. Install the lower halves of the crankshaft main bearings (4) into the crankshaft main bearing caps (3).

Note: Ensure that the main bearing tab fits in the tab groove of the crankshaft main bearing cap.

End By: Install the crankshaft. Refer to Disassembly and Assembly, "Crankshaft - Install".

Previous Screen

Product: EXCAVATOR

Model: 311D LRR EXCAVATOR DWR

Configuration: 311D LRR Excavator DWR00001-UP (MACHINE) POWERED BY C4.2 Engine

Disassembly and Assembly C4.2 Engine for Caterpillar Built Machines

Media Number -KENR8105-04

Publication Date -01/06/2013

Date Updated -12/06/2013

i02770396

Crankshaft - Remove

SMCS - 1202-011

Removal Procedure

Table 1

| Required Tools | | | |
|----------------|-------------|-----------------------|-----|
| Tool | Part Number | Part Description | Qty |
| A | 6V-9120 | Socket ⁽¹⁾ | 1 |

⁽¹⁾ Tooling (A) is a 46 mm socket.

Start By:

- A. Remove the front housing. Refer to Disassembly and Assembly, "Housing (Front) - Remove".
- B. Remove the crankshaft rear seal. Refer to Disassembly and Assembly, "Crankshaft Rear Seal - Remove".
- C. Remove the flywheel housing. Refer to Disassembly and Assembly, "Flywheel Housing - Remove and Install".
- D. Remove the engine oil pan. Refer to Disassembly and Assembly, "Engine Oil Pan - Remove and Install".

NOTICE

Keep all parts clean from contaminants.

Contaminants may cause rapid wear and shortened component life.

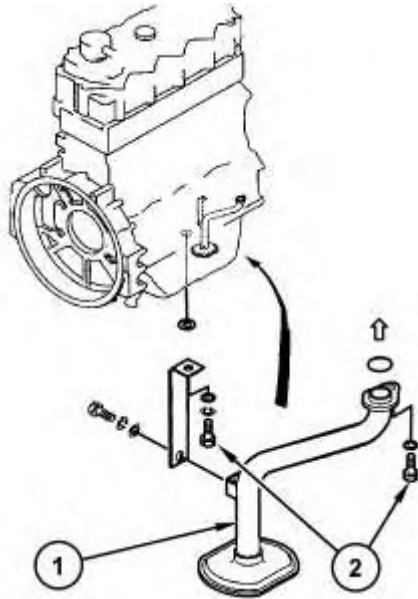

Illustration 1

g01385561

1. Remove bolts (2) from oil supply tube (1). Remove oil supply tube (1) and the O-ring seal from the engine cylinder block.

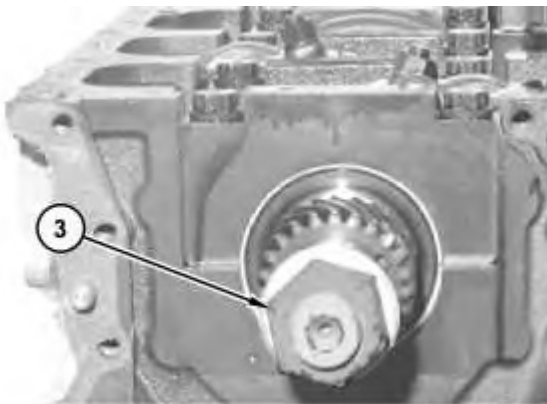

Illustration 2

g01377302

2. Install nut (3) and the washer onto the crankshaft. Use Tooling (A) in order to turn the crankshaft.
-

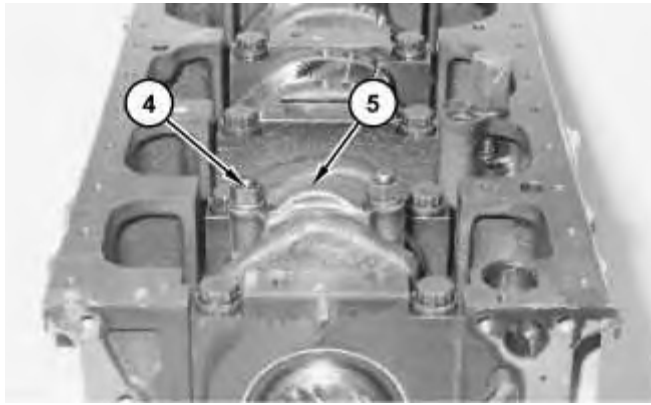

Illustration 3

g01385745

3. Remove nuts and bolts (4) that secure connecting rod caps (5) to the connecting rods. Remove connecting rod caps (5) from the connecting rods.

Note: Be careful not to damage the bearings. Mark each connecting rod cap and the bearing in order to ensure installation in the original location.

Note: Apply tape or rubber tubing to the connecting rod bolts.

4. Carefully push the connecting rods and the pistons into the top of the bores.

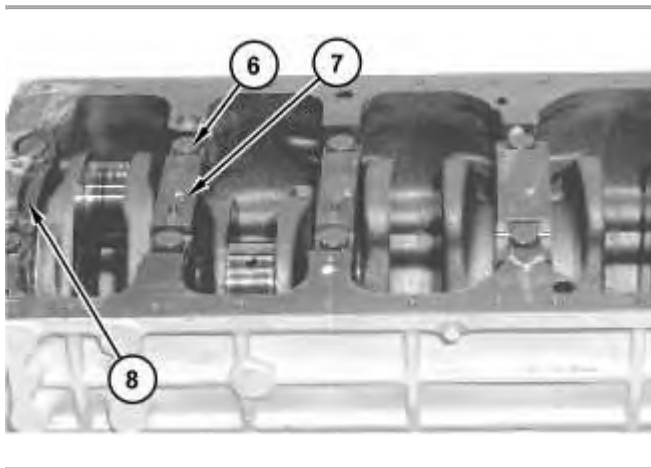

Illustration 4

g01385754

5. Remove bolts (6) that secure crankshaft main bearing caps (7) and rear main bearing cap (8) in position in the engine cylinder block. Remove crankshaft main bearing caps (7) and rear main bearing cap (8) from the engine.

Note: Be careful not to damage the bearings. Mark each crankshaft main bearing cap and the bearing in order to ensure installation in the original location.

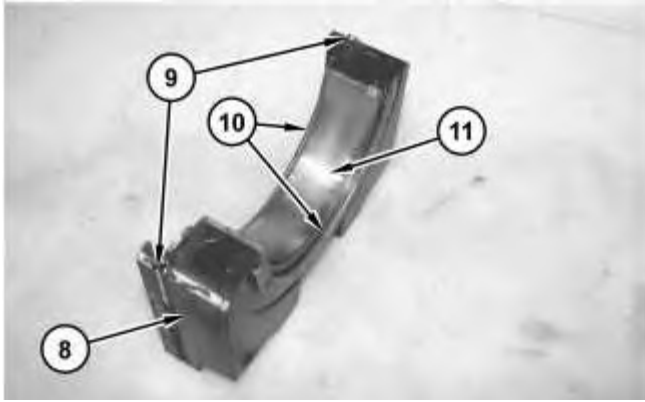

Illustration 5

g01377324

This Illustration is of the rear main bearing cap.

6. Remove seals (9), thrust washers (10), and main bearing (11) from rear main bearing cap (8). Remove main bearings (11) from crankshaft main bearing caps (7) (not shown).



Illustration 6

g01377339

Typical Example

7. Attach a suitable lifting device to crankshaft (12). The weight of crankshaft (12) is approximately 40 kg (88 lb). Use the suitable lifting device in order to remove crankshaft (12).

Note: Be careful not to damage the finished surfaces on crankshaft (12).

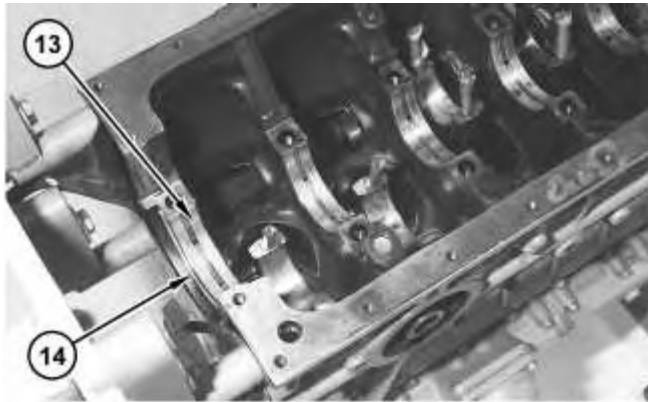

Illustration 7

g01377349

8. Remove the upper halves of crankshaft main bearings (13). Remove thrust washer (14) .

Note: Note the orientation of thrust washer (14) for assembly purposes.

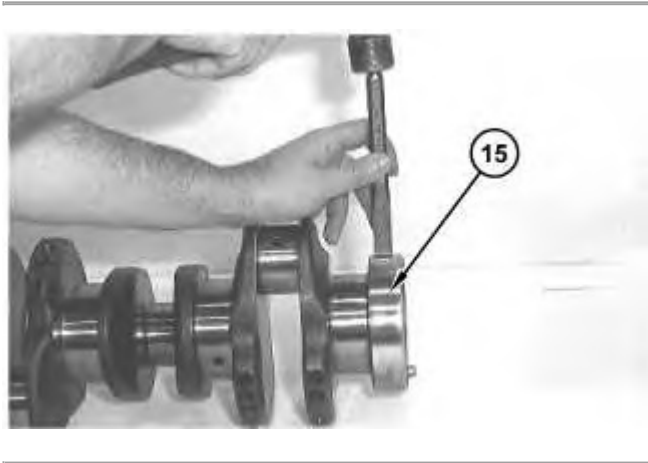

Illustration 8

g01377357

9. If necessary, use a suitable hammer and a suitable chisel in order to remove wear sleeve (15) for the crankshaft rear seal. Hold the suitable chisel at right angles to the surface of the wear sleeve. Tap the wear sleeve in three places. You can remove the wear sleeve once the tension is released.

Note: When you are removing the wear sleeve, take extreme care not to damage the crankshaft.

Note: Take extreme care not to damage the wear sleeve, if it is not necessary to remove the wear sleeve.

Previous Screen

Product: EXCAVATOR

Model: 311D LRR EXCAVATOR DWR

Configuration: 311D LRR Excavator DWR00001-UP (MACHINE) POWERED BY C4.2 Engine

**Disassembly and Assembly
C4.2 Engine for Caterpillar Built Machines**

Media Number -KENR8105-04

Publication Date -01/06/2013

Date Updated -12/06/2013

i02770970

Crankshaft - Install

SMCS - 1202-012

Installation Procedure

Table 1

| Required Tools | | | |
|----------------|-------------|-----------------------|-----|
| Tool | Part Number | Part Description | Qty |
| A | 6V-9120 | Socket ⁽¹⁾ | 1 |
| B | 8T-5096 | Dial Indicator | 1 |
| C | 8T-9022 | Silicone Gasket | 1 |
| D | 198-9113 | Seal Installer | 1 |

⁽¹⁾ Tooling (A) is a 46 mm socket.

NOTICE

Keep all parts clean from contaminants.

Contaminants may cause rapid wear and shortened component life.

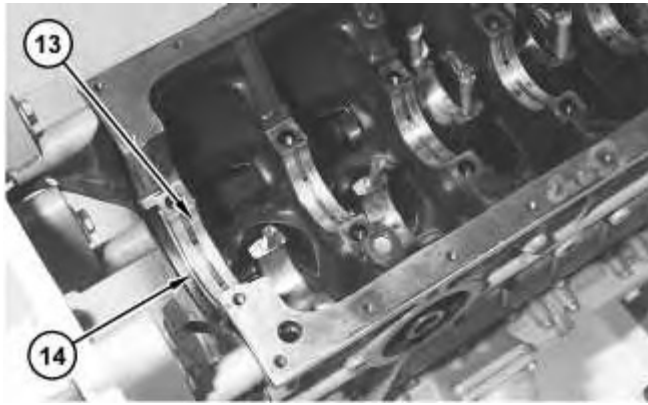

Illustration 1

g01377349

1. Install thrust washer (14) on the rear face of the crankshaft with the oil groove toward the outside.
2. Position the upper halves of crankshaft main bearings (13) in the cylinder block. Install the bearings with the main bearing tabs in the correct position. Lubricate the bearings with clean engine oil.



Illustration 2

g01377339

3. Lubricate the crankshaft journals with clean engine oil. Attach a suitable lifting device to crankshaft (12). The weight of crankshaft (12) is approximately 40 kg (88 lb). Use the suitable lifting device in order to position crankshaft (12) onto the upper halves of the crankshaft main bearings.

Note: Be careful not to damage the finished surfaces on the crankshaft.

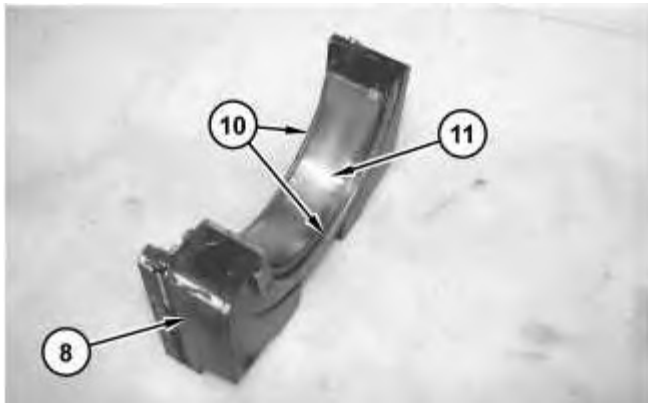

Illustration 3

g01377519

This Illustration is of the rear main bearing cap.

4. Install main bearings (11) onto crankshaft main bearing caps (7) (not shown). Install main bearing (11) onto rear main bearing cap (8). Install bearings (11) with the main bearing tabs in the correct position. Lubricate main bearings (11) with clean engine oil.
5. Install thrust washers (10) onto rear main bearing cap (8). Make sure that the oil grooves on thrust washers (10) are facing away from rear main bearing cap (8) .

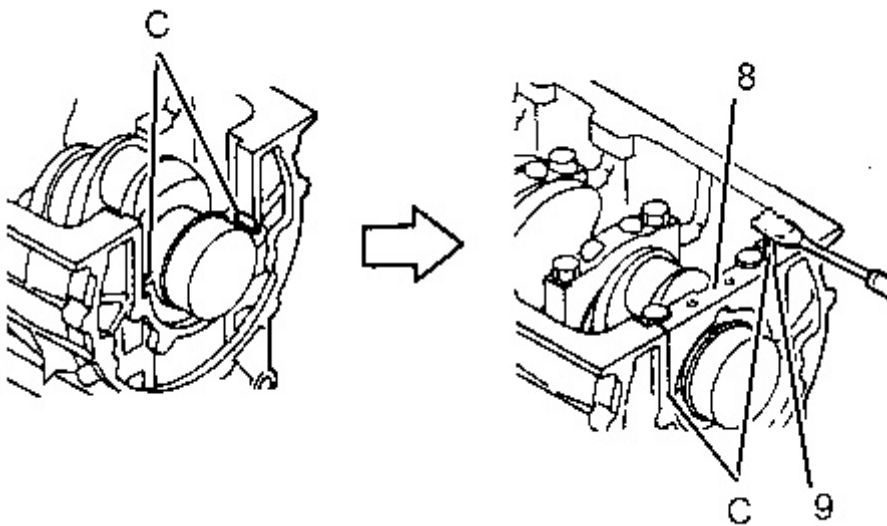

Illustration 4

g01377377

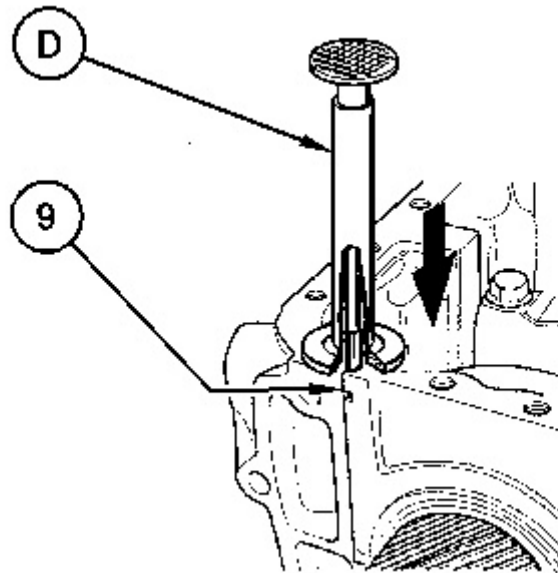

Illustration 5

g01385779

6. Apply Tooling (C) to the corners and the sides of rear main bearing cap (8). Install rear main bearing cap (8) to the cylinder block so that the rear face is even with the rear face of the cylinder block.
7. Apply soapy water to seals (9). Position seals (9) in the grooves on rear main bearing cap (8) with the rounded edges of seals (9) toward the outside. Use Tooling (D) in order to push seals (9) into position. This will reduce the risk of damaging the metal cores of seals (9). Apply Tooling (C) around seals (9). Cut off any excess length of seals (9) .

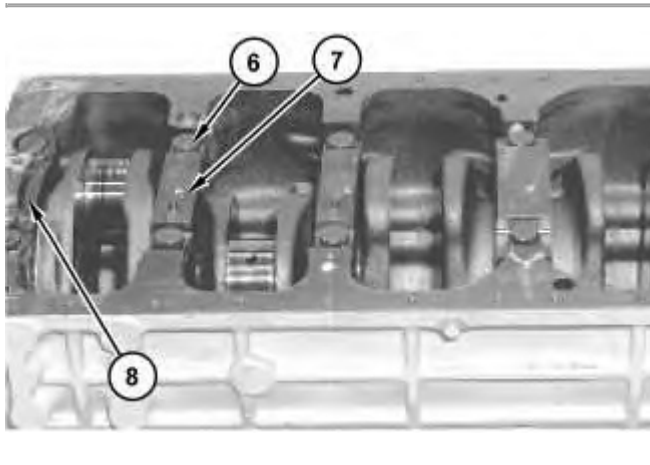

Illustration 6

g01385754

8. Install crankshaft main bearing caps (7). Put clean engine oil on the threads of new main bearing cap bolts (6). Install main bearing cap bolts (6). Tighten main bearing cap bolts (6) evenly to a torque of $137 \pm 5 \text{ N}\cdot\text{m}$ ($101 \pm 4 \text{ lb ft}$).

Note: Ensure that crankshaft main bearing caps (7) are installed in the original locations.

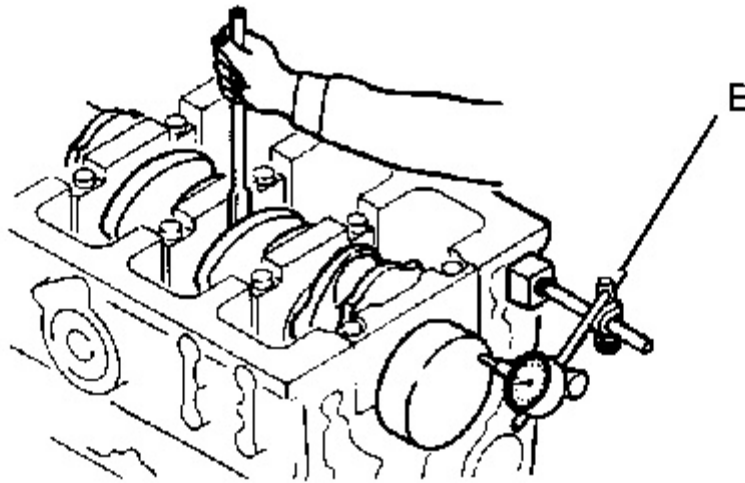

Illustration 7

g01377571

9. Check the end play of the crankshaft with Tooling (B). The end play must be 0.100 to 0.264 mm (0.0039 to 0.0104 inch). Refer to the Specification, "Crankshaft" for more information on crankshaft end play.

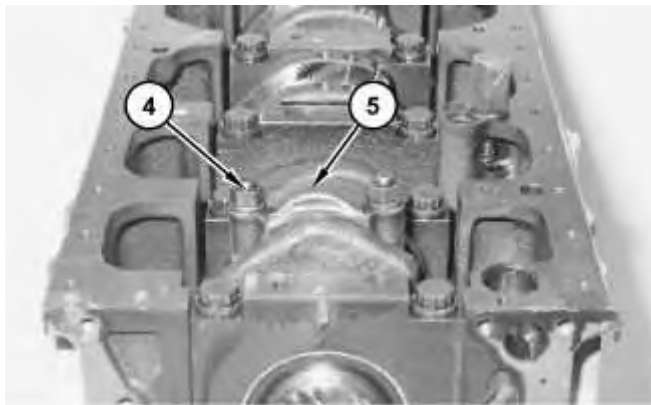

Illustration 8

g01385745

Note: Remove tape or rubber tubing from the connecting rod bolts.

10. Apply a light coat of clean engine oil to the connecting rod bearing surfaces and to the connecting rod journals. Install the connecting rods onto the connecting rod journals.
11. Install the lower half of the connecting bearings into the corresponding connecting rod caps and install connecting rod caps (5) .

Note: Align the tabs on the back of the connecting rod bearings with the tab grooves in connecting rod caps (5). Install new bolts (4) and the new nuts. Tighten bolts (4) to a torque of $103 \pm 5 \text{ N}\cdot\text{m}$ ($76 \pm 4 \text{ lb ft}$).

12. Install the pistons and connecting rods. Refer to Disassembly and Assembly, "Pistons and Connecting Rods - Install".

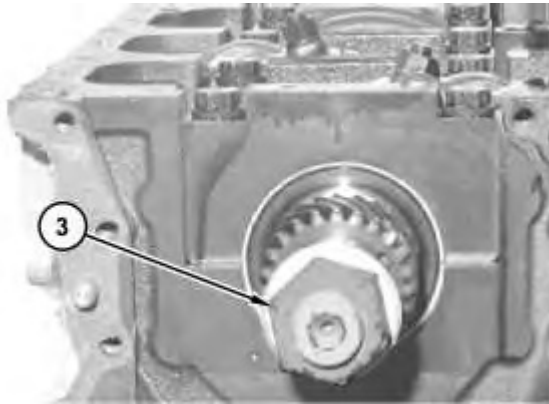

Illustration 9

g01377302

13. Check for free crankshaft rotation by rotating the crankshaft for two complete revolutions. Use Tooling (A) on nut (3) in order to rotate the crankshaft.

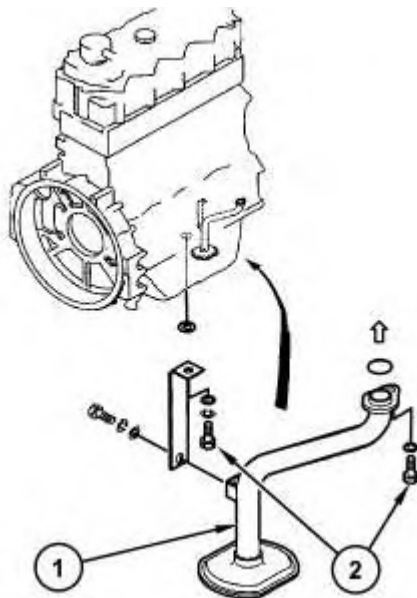

Illustration 10

g01385561

14. Position oil supply tube (1) and the O-ring seal. Install bolts (2) in order to secure the oil supply tube to the cylinder block.

End By:

- a. Install the engine oil pan. Refer to Disassembly and Assembly, "Engine Oil Pan - Remove and Install".

- b. Install the flywheel housing. Refer to Disassembly and Assembly, "Flywheel Housing - Remove and Install".
- c. Install the crankshaft rear seal, if the crankshaft wear sleeve was removed. Refer to Disassembly and Assembly, "Crankshaft Rear Seal - Install".
- d. Install the front housing. Refer to Disassembly and Assembly, "Housing (Front) - Install".

Previous Screen

Product: EXCAVATOR

Model: 311D LRR EXCAVATOR DWR

Configuration: 311D LRR Excavator DWR00001-UP (MACHINE) POWERED BY C4.2 Engine

**Disassembly and Assembly
C4.2 Engine for Caterpillar Built Machines**

Media Number -KENR8105-04

Publication Date -01/06/2013

Date Updated -12/06/2013

i01131265

Crankshaft Gear - Remove and Install

SMCS - 1204-010-GE

Removal Procedure

Table 1

| Required Tools | | | |
|----------------|-------------|---------------------|-----|
| Tool | Part Number | Part Description | Qty |
| A | 1P-0820 | Hydraulic Puller | 1 |
| | 9U-6600 | Hand Hydraulic Pump | 1 |
| | 0S-2398 | Step Plate | 1 |
| | 3H-0468 | Puller Plate | 4 |
| | 8B-7549 | Puller Leg | 2 |
| | 1B-4207 | Full Nut | 2 |
| | 8B-7551 | Bearing Puller | 1 |

Start By:

- a. Remove the crankshaft. Refer to Disassembly and Assembly, "Crankshaft - Remove".
-



Suggest:

If the above button click is invalid.

Please download this document

first, and then click the above link

to download the complete manual.

Thank you so much for reading

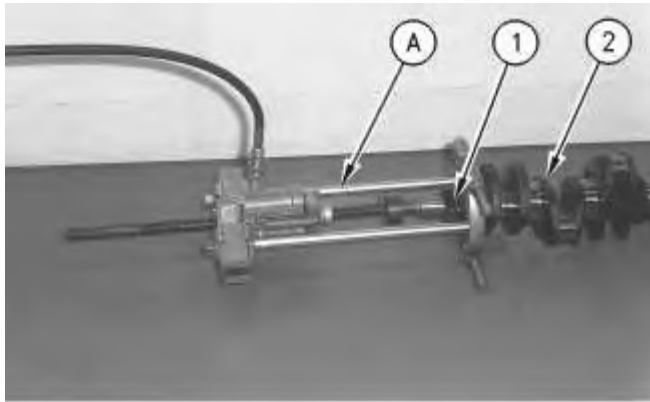

Illustration 1

g00541880

1. Use Tool (A) to remove crankshaft gear (1) from crankshaft (2).

Note: Do not remove the gear by tapping with a hammer.

Note: Be careful not to damage the finished surfaces on the crankshaft.

2. Check the key on the crankshaft. If the key is damaged, use a new part for replacement.

Installation Procedure

NOTICE

Keep all parts clean from contaminants.

Contaminants may cause rapid wear and shortened component life.



Always wear protective gloves when handling parts that have been heated.

1. Use an oven and heat the crankshaft gear to a temperature of about 100 °C (212 °F). The crankshaft gear is heated in order to ease installation of the crankshaft gear.



Wear eye protection in order to prevent possible personal injury while performing the following steps.

<https://www.ebooklibonline.com>

Hello dear friend!

Thank you very much for reading.

Enter the link into your browser.

The full manual is available for immediate download.

<https://www.ebooklibonline.com>