

TABLE OF CONTENTS

2870 TRACTORS

SERIES	SECTION	DESCRIPTION	FORM NUMBER
10	GENERAL		
	1010	General Specifications - 2870 Tractors	9-80416
	1012	Lubrication - 2870 Tractors	9-80405
	1120	Engine - 674 Cu. In.	9-80076
	1130	Fuel System	9-80425
	1040	Hydraulics	9-80445
	1050	Steering System	9-80455
	1060	Power Train	9-80465
	1070	Brake System	9-80475
20	ENGINES		
	2101	Engine Diagnosis	9-80085
	2102	Engine Tune-Up	9-80056
	2110	Engine Removal	9-80205
	2115	Cylinder Head, Valves and Rocker Arms	9-79836
	2120	Cylinder Block, Sleeves, Pistons and Rods	9-79845
	2125	Crankshaft and Main Bearings	9-79855
	2130	Camshaft, Bushings and Valve Lifters	9-79866
	2140	Flywheel and Rear Oil Seal	9-79905
	2145	Lubrication System, Pump, Cleaner, Relief Valve & Heat Exchanger	9-79885
	2155	Cooling System, Water Pump and Thermostats	9-79895
	2165	Turbocharger, 674 Cu. In. Engine	9-79955
	2175	Air Induction and Exhaust System	9-80155
	2655	Engine Lubrication	9-79975
	2290	Reconditioning Engine Cylinder Block	8-21170
30	FUEL SYSTEM		
	3110	Fuel System and Filters	9-80495
	3112	Fuel Injection Pump and Pump Drive	9-79946
	3113	21MM Fuel Injectors - Robert Bosch	9-80815
40	ELECTRICAL		
	4010	Tractor Wiring Diagram - Starting with Tractor SN 8825418	9-80955
	4010	Tractor Wiring Diagram - Prior to Tractor SN 8825418	9-80185
	4011	Tractor Cab Wiring Diagram - Starting with Cab SN 7882601	9-80965
	4011	Tractor Cab Wiring Diagram - Prior to Cab SN 7882601	9-80486
	4012	Starting or Cranking Motors	9-80595
	4013	Battery Servicing and Testing	9-80565
	4114	Delco-Remy 10 SI Series Alternator Systems	9-80586
	4115	Delco-Remy 10 SI Series Alternator System	9-45891
	4020	Neutral Start Switch Adjustment	9-80575
50	STEERING		
	5005	Testing Tractor Steering System	9-80915
	5010	Steering Column With Steering Pump	9-80526
	5011	Steering Cylinders	9-80515
	5012	Rear Steer Control Valve & Load Check Valve	9-80535
	5013	Steering Lines, Linkage and Cables	9-80865
	5014	Front and Rear Steering Adjustments	9-46001
	5015	Proportional Flow Divider Valve	9-80545

60

POWER TRAIN

6001	Trouble Shooting RPS-34 Power Shift Transmission	9-76037
6005	Testing RPS-34 Power Shift and PTO	9-80885
6012	Axles and Planetaries	9-80635
6016	Differentials and Drive Shafts	9-80735
6020	Torque Limiter Clutch	9-80295
6030	RPS-34 Power Shift	9-80236
6035	RPS Power Shift Control Valve and Linkage	9-80435
6040	Four Speed Transmission	9-80335
6045	Hydraulic PTO-Clutch, Valve, Dropbox & Lines	9-80725

70

BRAKES

7010	Brake Master Cylinder, Brake Pedal, Parking Brake Assembly	9-80826
------	--	---------

80

HYDRAULICS

8005	Testing Tractor Hydraulic System	9-80925
8010	Hydraulic Oil Filters and Lines	9-80805
8011	Triple Hydraulic Pump and Lines	9-80715
8012	Pressure Regulator Valve and Lines	9-80765
8013	Installation and Adjustment of Remote Valves	9-80695
8014	L.H. and R.H. Remote Hydraulic Valves	9-80625
8016	3 Point Hitch and Hitch Coupler	9-80745
8017	Hitch Control Valve and Lines	9-80755
8018	Hyd. 3 Point Hitch Cylinders and Lines	9-80555
8019	Portable Hydraulic Cylinders	9-80615

90

ACCESSORIES

9005	Trouble Shooting Air Conditioning System	9-78895
9015	Gauging and Testing Air Conditioning System	9-78995
9025	Compressor Isolation, Removal, Installation and Evacuation - Discharging, Evacuation and Charging the A/C System	9-79015
9035	Servicing Air Conditioning Components	9-80895
9045	Servicing the Cab Blower Assembly	9-80905
9050	Operator's Seat Adjustments	9-79755
9060	Removal of Hood, Panels and Grille	9-80165
9065	Repair of Urethane Hood, Panels and Grille	9-80995

100

HOW IT WORKS

15001	Tractor Steering System Oil Flows	9-80795
15010	Steering Hand Pump and Valve	9-80255
15012	Rear Steer Control Valve & Check Valve	9-80345
15015	Proportional Flow Divider Valve	9-80775
16030	Power Shift	9-80395
18001	Tractor Hydraulic System Oil Flows	9-80785
18011	Hydraulic Triple Pump	9-80315
18012	Pressure Regulator Valve	9-80305
18014	Remote Hydraulic Valve	9-80355
18015	Hydraulic PTO Clutch, Valve and Dropbox	9-80285
18017	Three Point Hitch Valve	9-80365
19010	Air Conditioning - Theory of Operation	9-78615

<https://www.ebooklibonline.com>

Hello dear friend!

Thank you very much for reading.

Enter the link into your browser.

The full manual is available for immediate download.

<https://www.ebooklibonline.com>

Section 1010

2870 TRACTOR GENERAL SPECIFICATIONS

SERIAL NUMBERS

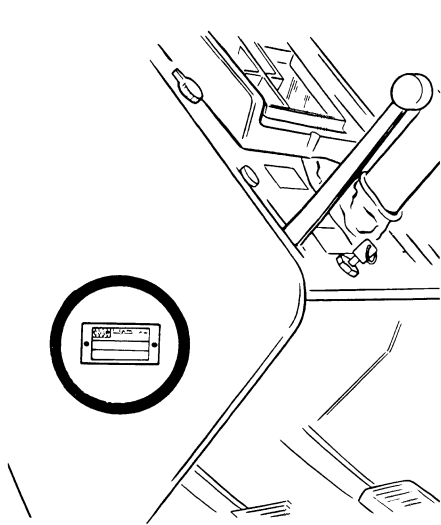

TRACTOR SERIAL NUMBER

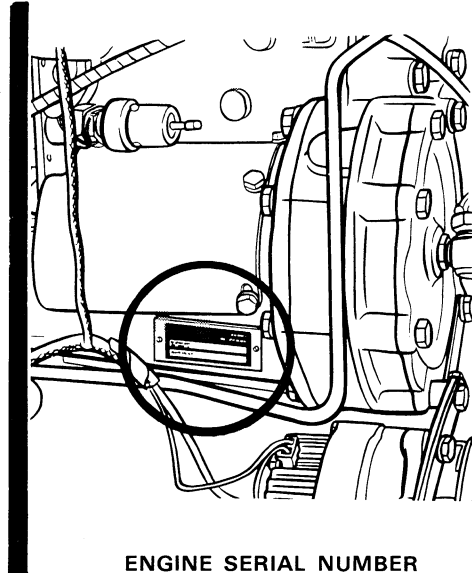

ENGINE SERIAL NUMBER

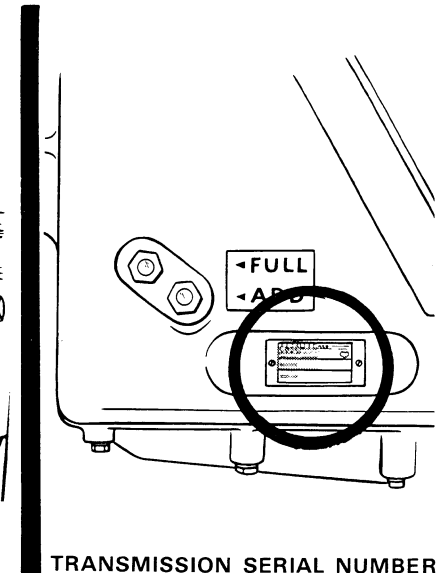

TRANSMISSION SERIAL NUMBER

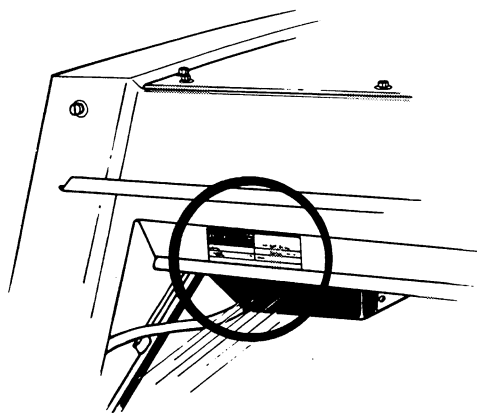

CAB SERIAL NUMBER

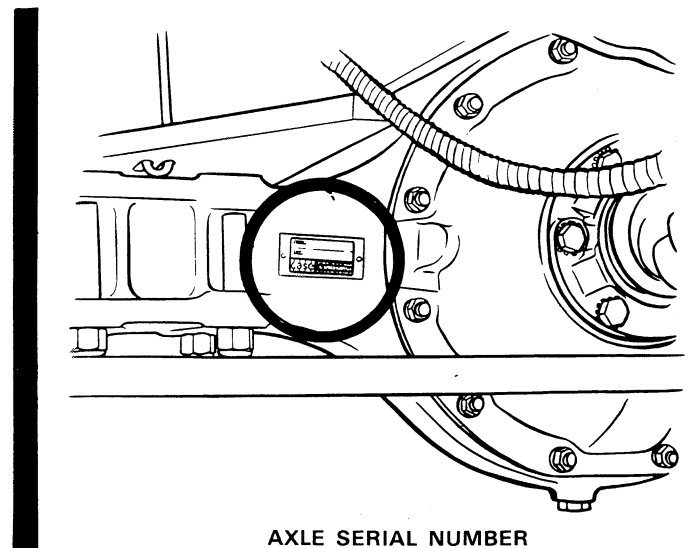

AXLE SERIAL NUMBER

DIESEL ENGINE

General

Type	6 Cylinder, 4 Stroke Cycle, Valve-In-Head, Turbocharged Diesel Engine
Firing Order	1-5-3-6-2-4
Bore	5 Inches (127mm)
Stroke	5.71 Inches (145mm)
Piston Displacement	674 Cubic Inches (11 045 cm ³)
Compression Ratio	14.7 to 1
Cylinder Sleeves	Removable Wet Type
No Load Governed Speed	2330 to 2420 RPM
Rated Engine Speed	2200 RPM
Engine Idling Speed	750 to 800 RPM
*Valve Tappet Clearance (Exhaust)	(Cold) .031 Inch (0.80mm)
	(Intake) (Cold) .014 Inch (0.35mm)

Piston and Connecting Rod

Rings per Piston	4
Number of Compression Rings	3
Number of Oil Rings	1
Type Pins	Full Floating Type
Type Bearings	Replaceable Steel Back With Lead-Bronze Liners

Main Bearings

Number of Bearings	7
Type Bearings	Replaceable, Steel Back with Lead-Bronze Liners

Engine Lubrication System

Oil Pressure	65 to 87 PSI (448 to 600 kPa)
	Engine Warm and Operating at Rated Engine Speed
Type System	Pressure and Spray Circulation
Oil Pump	Gear Type
Oil Filtration	Oil Cleaned Continuously by Cyclonic Separation and Centrifugal Cleaner.
Oil Capacity	28.4 U.S. Qts. (26.9 litres)
Oil Cooling	Oil Cooler Flange Mounted to Oil Cleaner; Water Cooling.
Turbocharger Oil Filter	Full Flow Spin-On Type

Fuel System

Fuel Injection Pump	Robert Bosch, Multiple Plunger
Pump Timing	20 Degrees Before Top Dead Center
Fuel Injectors	Robert Bosch, 21mm Opening Pressure 2930 to 3045 PSI (20 202 to 20 995 kPa)
Fuel Transfer Pump	Plunger Type, Integral Part of Injection Pump
Governor	Variable Speed, Fly-Weight Centrifugal Type, Integral Parts of Injection Pump.
First Stage Filter	Full Flow Spin-On Type
Second Stage Filter	Full Flow Spin-On Type
Fuel Tank Water Trap and Drain (2)	Located in Base of Each Fuel Tank
Fuel Tank Capacity	75 U.S. Gallons (283.9 litres) Each Tank
Fuel Level Gauge	Electric, Located on Instrument Panel
Hand Primer Pump	Located on Top of the Fuel Transfer Pump
Preliminary Fuel Filter	Located at the Bottom of the Fuel Transfer Pump

TRACTOR SPECIFICATIONS

Air Intake System

Type Air Induction System - Aspirated - Strata Tube
With Dry Type Final and Safety Elements.

Cooling System

Capacity of System 44 U.S. Quarts (41.6 litres)
Type of System Pressurized, Thermostat Controlled By-Pass Type:
Forced Circulation, (Centrifugal Type Pump).
Radiator Heavy Duty Fin and Tube Type
Thermostat (2) Thermostats Start to Open
approximately 175°F (79°C) Fully
Open at 202°F. (94°C.)
Pressure Cap Required 14 PSI (96.5 kPa)

Hydraulic Brakes

Type Self-Adjusting Multiple Disc Dry Type Transmission Brakes.

Parking Brake

Type Cable Actuated by over center Type Handle -
Adjustable from Operator's Seat. Multiple Disc Type

Electrical System

Type of System 12 Volt Negative Ground
Batteries (2) 12 Volt Batteries Connected in parallel
Group Size 30H, Rated in 1.255 to 1.265
Specific Gravity. Discharge Rate 300 Amps
at 0°F. Voltage drops to 9.2 after 10 sec-
onds. Voltage drops 1.0 Volt per cell after
5 min.
Alternator 12 Volt 61 Amp Output, Negative Ground
Voltage Regulator 12 Volt, Solid State, Internal Component of Alternator.
Starter Motor 12 Volt with Solenoid Switch
Head Lights (2) 12 Volt, 40/60 Watt Sealed High-Low Beam
Front Flood Lights (2) (optional) 12 Volt, 35 Watt Sealed Beam
L.H. Rear Flood and Tail Light (1) 12 Volt, 60 Watt Sealed Beam
Combination Tail and Flood Lamp.
R.H. Rear Flood (optional) (1) 12 Volt, 60 Watt Sealed Beam
Circuit Breaker System over Load Check Two 40 Amp. 12 Volt
Circuit Breakers connected in parallel, 80 Amp rating,
60 Amp. Min. Continuous Capacity.
Lights Circuit Breaker 40 Amp., Located on Light Switch
Parking Brake Warning Buzzer 12 Volt
Flasher Lights (2) With Directional Turn Signals 12 Volt, Amber Lens

Electrical System

Bulb and Lamp Replacement:

Instrument Cluster Warning Bulbs	No. 194
Instrument Cluster Illumination Bulbs	No. 168
Pyrometer Illumination Bulb	No. 53
Dome Light Bulb	No. 93
Console Light Bulb	No. 168
Flasher Light Bulbs	No. 1156
Front Driving Lamps	No. 4652
Front Flood Lamps	No. 4406
Rear Flood Lamp	No. 4466
Rear Flood and Tail Lamp:	
Lamp	No. 4469
Bulb	No. 1003

Power Shift Transmission

Type	3 Speed Compound Planetary With Hydraulically Actuated Clutches and a 4 Speed Gear Range Section.
Gear Selection	12 Speeds Forward and 4 Speeds Reverse.
Shifting	Hydraulic Power Shifting Controlled By a Lever on Operator's Console. 4 Speed Range Controlled by a Mechanical Shifter From a Lever on Operator's Console.
Oil Type	Case TFD (Transmission - Final Drive)
Oil Capacity (Without PTO)	40 U.S. Quarts (37.9 litres)
(With PTO)	44 U.S. Quarts (41.6 litres)

Hydraulic Pump

Type	Direct Drive, Gear Type, Triple Hydraulic Pump
First Section	Charging Pump, Capacity at 2200 Engine RPM - 44 GPM (166.6 l/min.)
Intermediate Section	Supplies oil to the Transmission Hydraulics and PTO. Capacity at 2200 Engine RPM - 17 GPM (64.4 l/min.).
Third Section	Supplies oil to the Steering System. Capacity at 2200 Engine RPM 19 GPM (71.9 l/min.).
Front Steering	9.8 GPM (37.1 l/min.)
Rear Steering	4.2 GPM (15.9 l/min.)

Hydrostatic Front Power Steering

Oil Supply	Triple Hydraulic Pump
HGA Hydrostatic Type	Integral and Bi-Directional Gerotor Metering Section, Actuated By The Steering Wheel.
Front Steering Cylinders	Two Double Acting Cylinders

Rear Power Steering

Oil Supply	Triple Hydraulic Pump
Control Valve Type	4 Way, Three Position Spool Type.
Rear Steering Cylinders	Two Double Acting Cylinders
Controls	Hand Lever on Instrument Panel (Manual or Automatic)

Axle Differential and Planetaries

Front and Rear	Spiral Bevel with Planetary Reduction in Hub.
Differential Oil Cap (Front & Rear) Each	24 U.S. Quarts (22.7 litres)
Planetary Oil Cap. eac. (Front & Rear) Each	12 U.S. Quarts (11.4 litres)

3 Point Hitch System

Type Control	Hand Lever
Type Valve	3 Positions - Raise - Hold - Lower with Speed Control
Type Draft Arms	Rigid Swinging, with Manual Float Adjustment
Type Hitch	3 Point Category III
Hitch Coupler	Case Available - Category III

L.H. Dual Remote Hydraulic System

Type Remote Valve (L.H. Side)	Dual Valve w/Built-in Female ASAE R366 Standard Hydraulic Couplers. Individual Hand Lever Control.
Portable Cylinder Male Couplings Available	Quick Detachable Break-away Type
Oil Supply	Triple Hydraulic Pump
Relief Valve Pressure	2150 to 2250 PSI (14 824 to 15 514 kPa)
Portable Cylinders	Case Cylinders Available

R.H. Dual Remote Hydraulic System

Oil Supply	From L.H. Remote Valve (Connected in Series)
Type Remote Valve (R.H. Side)	Dual Valve W/Built-in Female ASAE R366 Standard Hydraulic Couplers. Individual Hand Lever Control.
Relief Valve Pressure	Dependent on L.H. Remote
Portable Cylinder Male Couplings	Available Quick Detachable Break-away Type.
Portable Cylinders	Case Cylinders Available

Power Take-Off

Type Clutch Hydraulically Operated

Rotation Clockwise

Spline Size 20 Splines 1-3/4 In. (44.5mm) Dia.
Adapter 1-3/4" to 1-3/8" Dia. Available

Engine Speed 2200 RPM 1000 RPM Shaft Speed

Drawbar

Yoke Type Full Swinging Roller Mounted,
Will Accommodate a 1-1/2 Inch (38.1mm), Dia. Pin.

Tire and Wheel Equipment – Front and Rear

TIRE SIZE	TIRE PLY & TREAD	RIM SIZE	TIRE ** PRESSURE (No Added Ballast)	TIRE PRESSURE (With Max. Ballast or Heavy Implement)
18.4-34*	6 R1 & R2	W16L-34	16 PSI (110 kPa)	16 PSI (110 kPa)
18.4-34	8 R1 & R2	W16L-34	16 PSI*** (110 kPa)	20 PSI (138 kPa)
20.8-34	6 R1	W18L-34	14 PSI*** (97 kPa)	14 PSI (97 kPa)
20.8-34	8 R1 & R2	W18L-34	16 PSI*** (110 kPa)	18 PSI (124 kPa)
23.1-30	8 R1 & R2	W20L-30	16 PSI (110 kPa)	16 PSI (110 kPa)
24.5-32	10 R1 & R2	DW27-32DC	18 PSI (124 kPa)	20 PSI (138 kPa)
30.5-32	10 R1 & R2	DW27-32DC	16 PSI (110 kPa)	16 PSI (110 kPa)

*18.4-34, 6 ply tires can only be used with duals and on outside tires only.

**Minimum inflation pressure for single tires.

***Absolute minimum inflation pressure for tires used as duals is 12 PSI (82.7 kPa).

IMPORTANT: 18.4-34 and 20.8-34 singles are not suitable for use with ballast, either tire liquid or added weights, or with heavy mounted attachments.

Approximate Travel Speeds in MPH and KM/H at 2200 RPM with 12 Speed Power Shift Transmission

TRANSMISSION RANGE	POWER SHIFT			TIRE SIZE
	1	2	3 AND REVERSE	
1	2.0 mph (3.2 km/h)	2.7 mph (4.4 km/h)	3.4 mph (5.5 km/h)	23.1-30
2	3.1 mph (5.0 km/h)	4.1 mph (6.6 km/h)	5.1 mph (8.2 km/h)	
3	4.3 mph (6.9 km/h)	5.8 mph (9.3 km/h)	7.2 mph (11.6 km/h)	
4	7.9 mph (12.7 km/h)	10.7 mph (17.2 km/h)	14.7 mph (23.7 km/h)	
1	2.2 mph (3.5 km/h)	2.9 mph (4.7 km/h)	3.7 mph (6.0 km/h)	30.5-32
2	3.4 mph (5.5 km/h)	4.4 mph (7.1 km/h)	5.6 mph (9.0 km/h)	
3	4.6 mph (10.5 km/h)	6.2 mph (10.0 km/h)	7.7 mph (12.4 km/h)	
4	8.6 mph (13.8 km/h)	11.4 mph (18.3 km/h)	15.7 mph (25.3 km/h)	
1	2.0 mph (3.2 km/h)	2.7 mph (4.4 km/h)	3.3 mph (5.3 km/h)	18.4-34
2	3.0 mph (4.8 km/h)	4.1 mph (6.6 km/h)	5.1 mph (8.2 km/h)	
3	4.3 mph (6.9 km/h)	5.7 mph (9.2 km/h)	7.2 mph (11.6 km/h)	
4	7.9 mph (12.7 km/h)	10.6 mph (17.0 km/h)	14.5 mph (23.3 km/h)	
1	2.0 mph (3.2 km/h)	2.7 mph (4.3 km/h)	3.4 mph (5.5 km/h)	20.8-34
2	3.1 mph (5.0 km/h)	4.2 mph (6.8 km/h)	5.2 mph (8.4 km/h)	
3	4.4 mph (7.1 km/h)	5.9 mph (9.5 km/h)	7.4 mph (11.9 km/h)	
4	8.1 mph (13.0 km/h)	10.8 mph (17.4 km/h)	14.9 mph (24.0 km/h)	

Approximate Overall Measurements

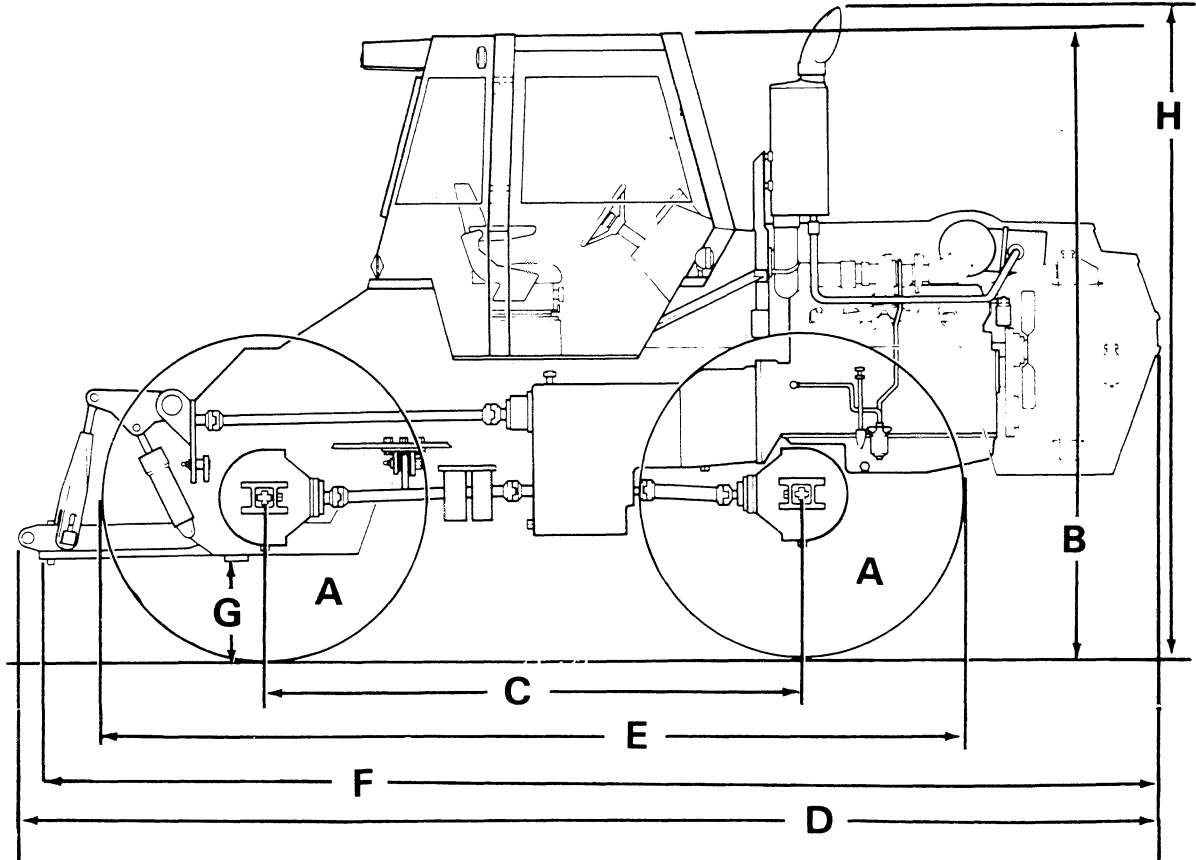

A	TIRE	WHEEL RIM	F	228 Inches (5 791mm)	
	23.1-30 RI	W20L-30			
B	123 Inches (3 124mm)	D	237 Inches (6 020mm)	G	18 Inches (457mm)
C	110 Inches (2 794mm)	E	175 Inches (4 445mm)	H	131 Inches (3 327mm)

Overall Width (Minimum)	99 Inches (2 515mm)
Turning Radius (Minimum)	210 Inches (5 334mm)
Overall Length (W/Hitch Coupler)	243 Inches (6 172mm)
Rear Axle Oscillation	30°

Approximate Shipping Weight

4 Wheel Steering w/20.8 x 34 Tires 18,500 Pounds (8392 kg)

IMPORTANT: The total tractor weight with ballast and weights must not exceed 28,500 lbs. (12 930 kg).

Operator's Cab

The Case Operators Cab is equipped with built-in roll over protection as specified in ASAE Standard S336.1, SAE Standard J168a, and OSHA Regulation 1928.53.

Section 2102

ENGINE TUNE-UP

ENGINE TUNE-UP

By following the step by step outline in this section a complete engine tune-up will be performed and a minimal amount of time will be required.

Top Dead Center - Checking	5-7
Cylinder Heads - Retorquing	8,9
Tappet Adjustment	9
Valve Timing - Checking	10
Nozzle Spray Pattern - Checking	11
Compression Check	11-13
Air Intake System - Cleaning and Servicing	14
Fuel Filters - Cleaning and Servicing	14
Injection Pump - Retiming	14
Engine Governed Speed - Checking	14
Fan Belt Adjustment	15

SPECIAL TOOLS

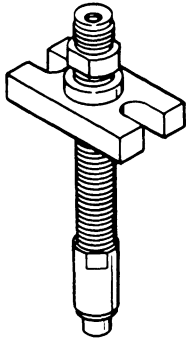

★ COMPRESSION GAUGE ADAPTER
BACHARACH 70-301

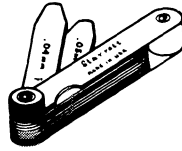

FEELER GAUGE

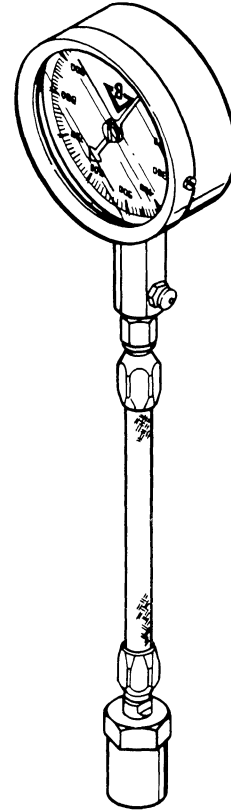

★ COMPRESSION GAUGE
BACHARACH 70-003



CAS-1003 INJECTOR BORE
CARBON REAMER

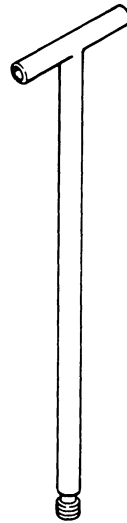

INJECTOR SEALING WASHER
EXTRACTOR - SEE PAGE 4

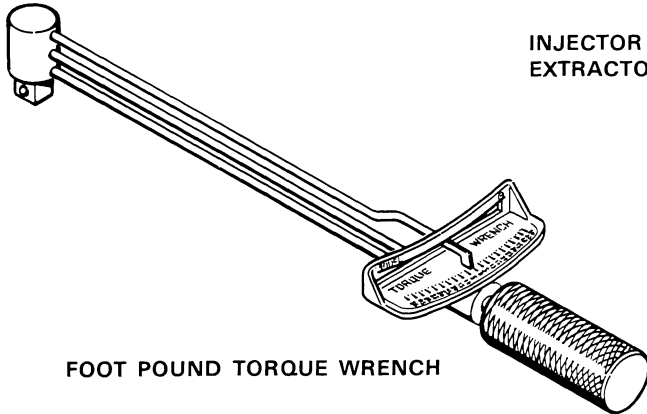

FOOT POUND TORQUE WRENCH

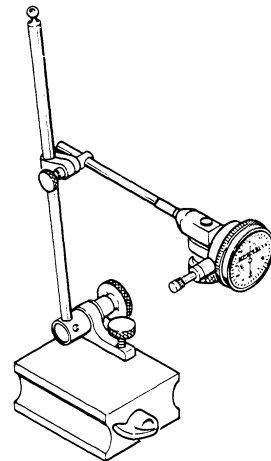

DIAL INDICATOR



VALVE SPRING COMPRESSOR
TOOL - SEE PAGE 4

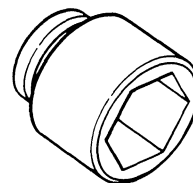

60mm (2-3/8") SOCKET

★ These tools are found in Case Kits M20247 and M20519

SPECIFICATIONS FOR TOOLS WHICH MUST BE MADE

1" O.D. X 1-1/4" LONG BUSHING

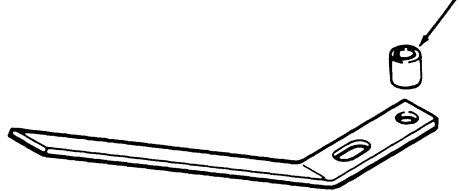

VALVE SPRING COMPRESSOR TOOL

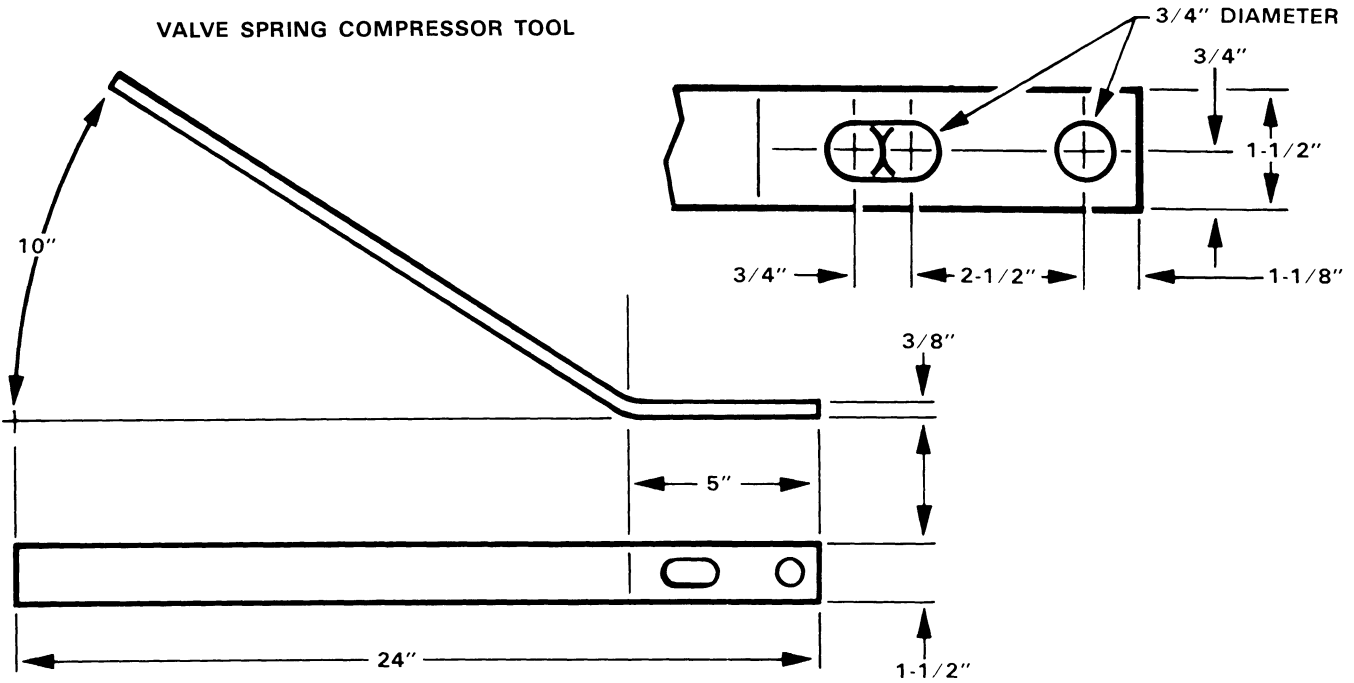

HANDLE OPTIONAL

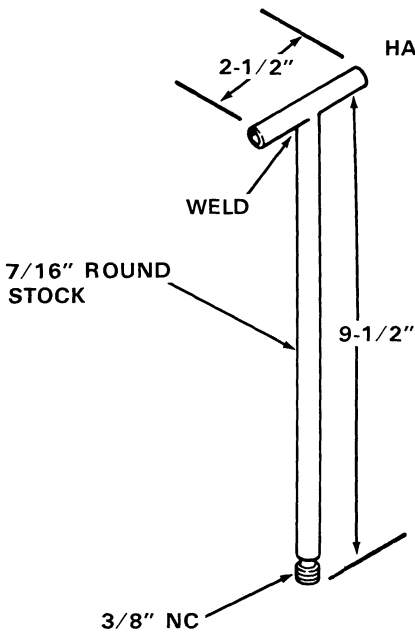

INJECTOR SEALING WASHER EXTRACTOR

ENGINE TUNE-UP PROCEDURE

Checking Top Dead Center

STEP 1

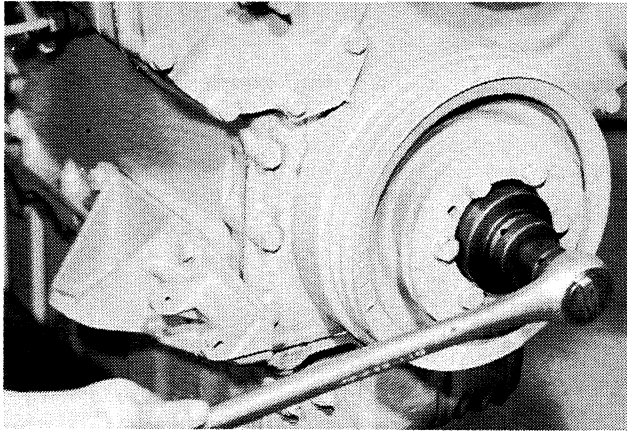
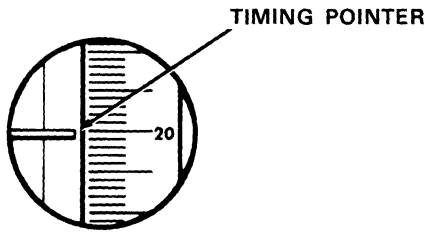

Crank engine until 20° BTDC mark on damper is aligned with timing pointer.

STEP 2

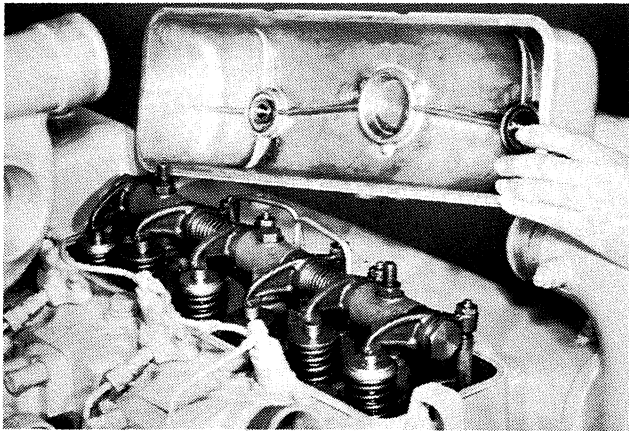

Remove turbocharger crossover tube and valve cover.

STEP 3

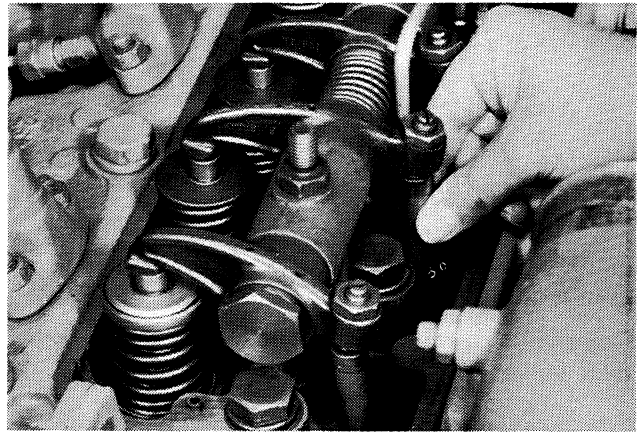

Check #1 cylinder push rods for looseness. If push rods are tight, crank engine one revolution and realign timing pointer with 20° BTDC mark.

STEP 4

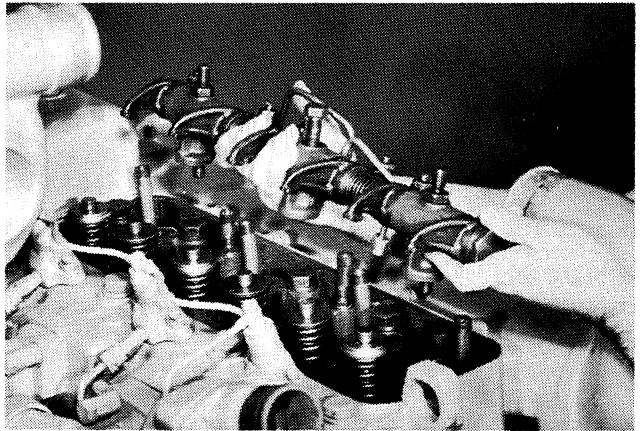

Remove the rocker arm assembly from cylinder head.

STEP 5

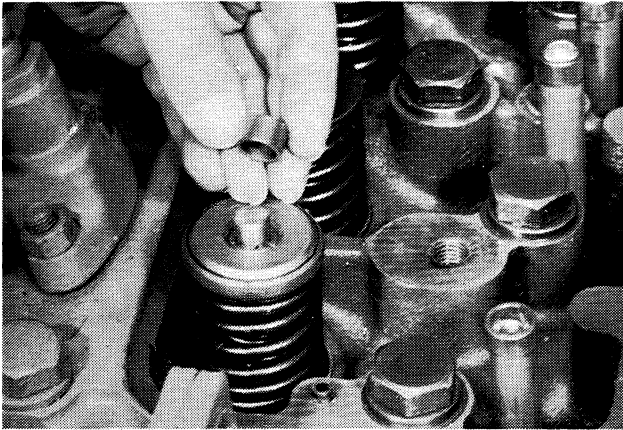

Remove the wear cap from No. 1 cylinder intake valve.

STEP 8



Remove the valve spring keeper and springs.

STEP 6

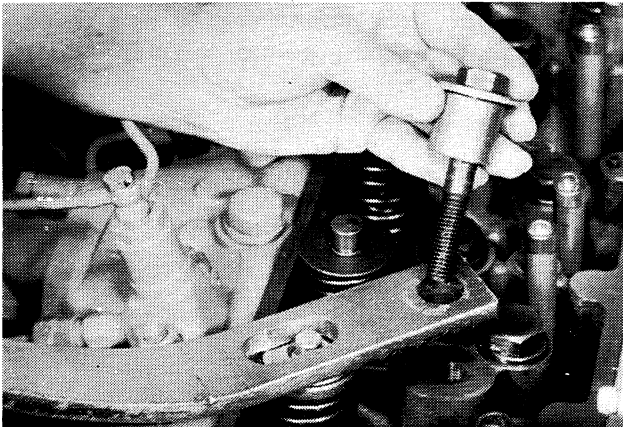

Install fabricated compression tool and bushing, see Page 4. *NOTE:* Use the center rocker arm mounting bolt to secure tool.

STEP 9

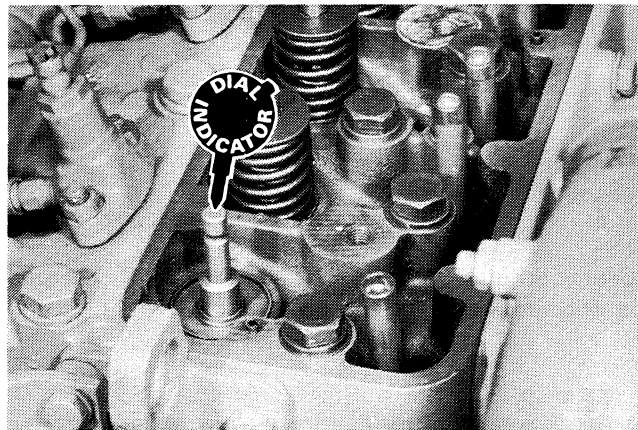

Place a dial indicator on the end of the valve stem with the valve resting on top of the piston.

STEP 7

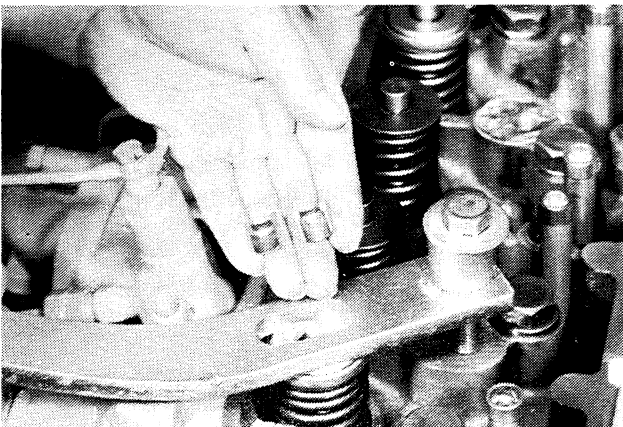

Compress valve springs and remove the valve keepers.

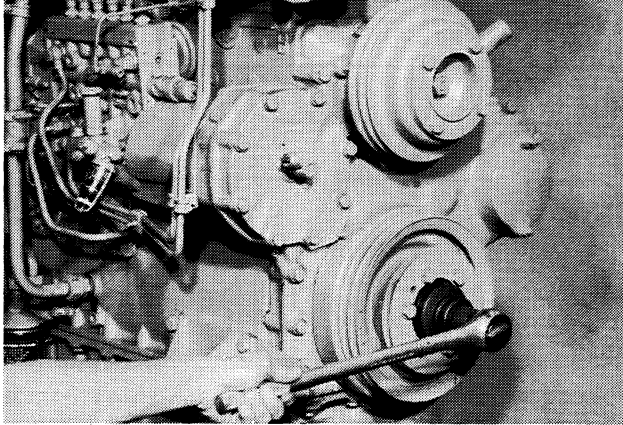
STEP 10

Crank engine clockwise until dial indicator hand stops moving. Reset indicator to zero.

Crank engine clockwise until .010" shows on dial indicator. Scribe a mark on crankshaft damper in line with the timing pointer.

Crank engine counter-clockwise past zero until .010" shows on dial indicator. Again, scribe a mark on crankshaft damper in line with timing pointer.

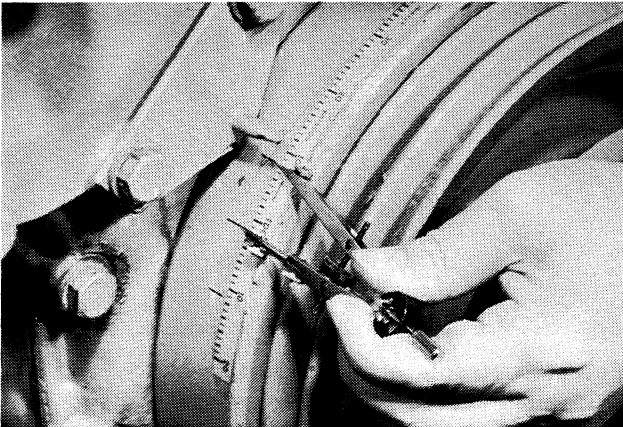
STEP 11

Half the distance between these two scribe marks on crankshaft damper will be top dead center (TDC). If the timing strip does not agree with this mark, remove strip and reposition it to agree with TDC mark.

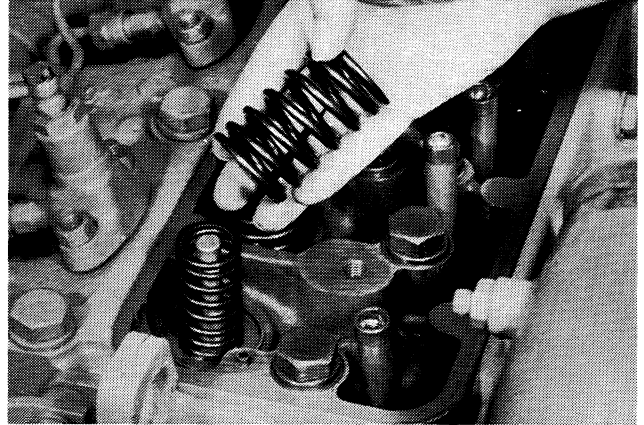
STEP 12

Install the inner and outer valve springs with the close coil end of springs towards cylinder head.

STEP 13

Place the valve spring keeper on top of the springs.

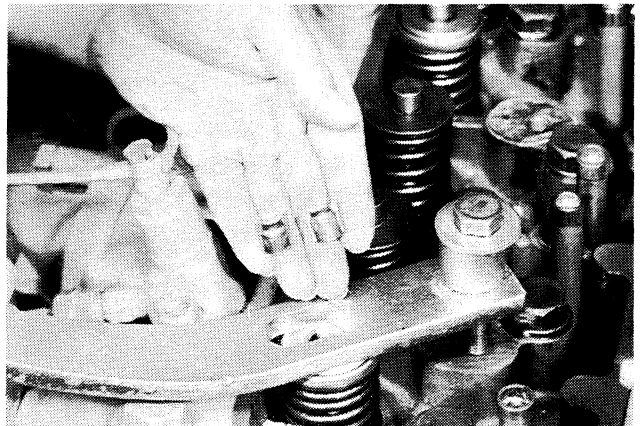
STEP 14

Compress the valve springs and install the valve keepers. Then remove compression tool and tap valve stem to insure keepers are firmly seated.

Retorquing Cylinder Heads

STEP 15

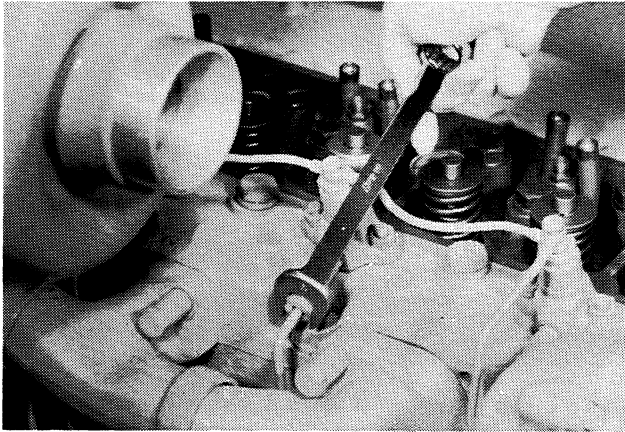

Disconnect the high pressure fuel supply lines to the injectors and remove the inline filter from the injectors. This will provide access to the 18mm cylinder head bolts. **IMPORTANT:** Use extreme care when removing inline filters and cap all opening to prevent dirt entering fuel injectors.

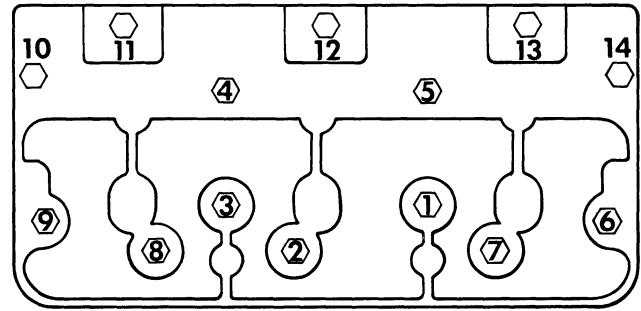

Retorque 16mm bolts to 177 ft. lbs., using a 24mm socket and 18mm bolts to 221 ft. lbs., using a 27mm socket. Back off each cylinder head bolt individually 2 or 3 turns. Put 5 or 6 drops of clean engine oil under the head of the bolt and under the hardened washer. Then retorque bolt to specific torque following sequence shown.

IMPORTANT: Do not back off all the bolts at the same time. Recheck the torque to make sure all bolts have retained the specified torque

STEP 16

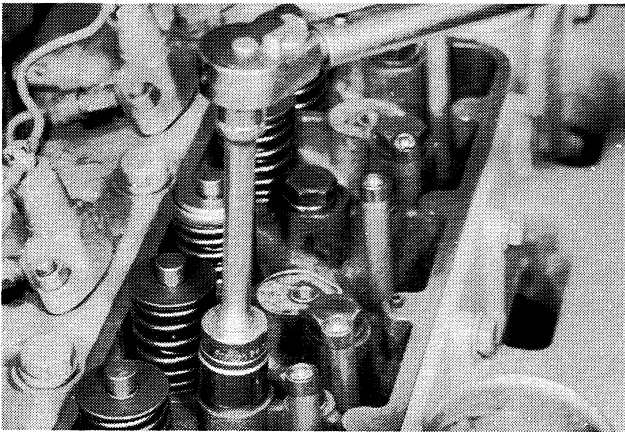

Retorque the cylinder head bolts following the torquing sequence shown. **IMPORTANT:** This function must be performed while the engine is hot.

STEP 17

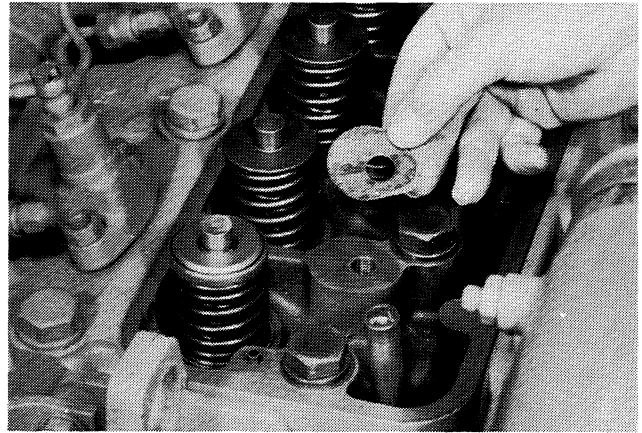

Reinstall rocker arm bracket gaskets, replace if damaged. **NOTE:** These gaskets have the task of sealing the oil pressure in the rocker arms, therefore it is important that gaskets are installed.

STEP 18

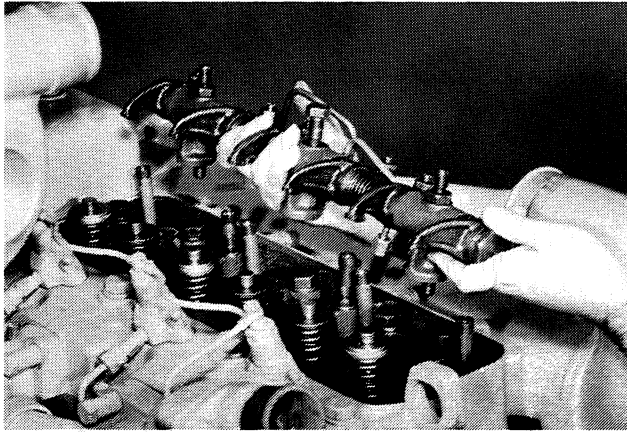

Reinstall the rocker arms on the cylinder heads.

STEP 19

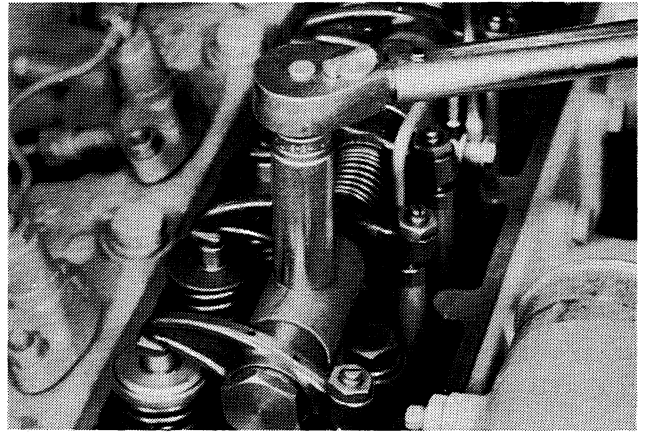

Torque the bracket retainer bolts to 61 ft. lbs.

Tappet Adjustment

STEP 20

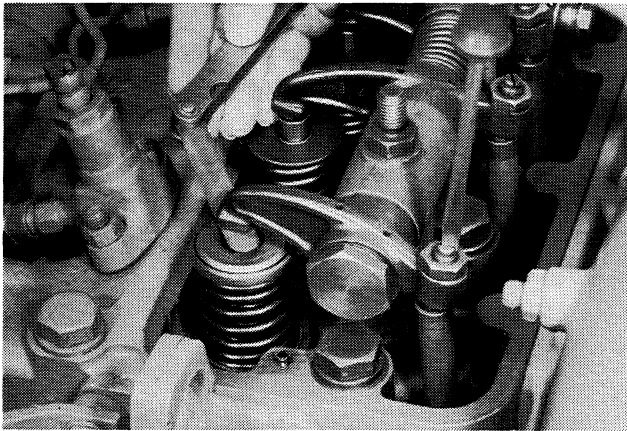

Check and adjust the intake and exhaust valves as pointed out by the arrows below. **IMPORTANT:** Tappet adjustment must be performed on a cold engine (engine allowed to cool down a minimum of 1/2 hour after shutdown).

Tappet Clearance - Intake Valves .014"
Exhaust Valves .031"

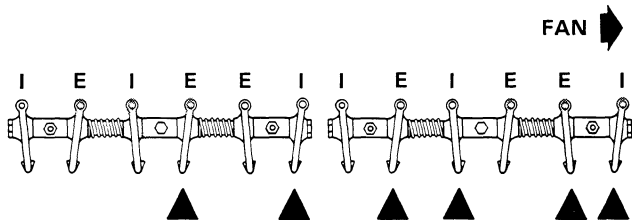

NO. 1 TDC COMPRESSION STROKE

STEP 21

Crank the engine one complete revolution and align the timing pointer with the TDC mark.

Check and adjust the intake and exhaust valves as pointed out by the arrows below.

Tappet Clearance - Intake Valves .014"
Exhaust Valves .031"

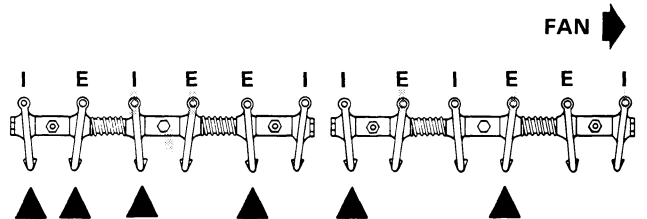

NO. 6 TDC COMPRESSION STROKE

Checking Valve Timing

STEP 22

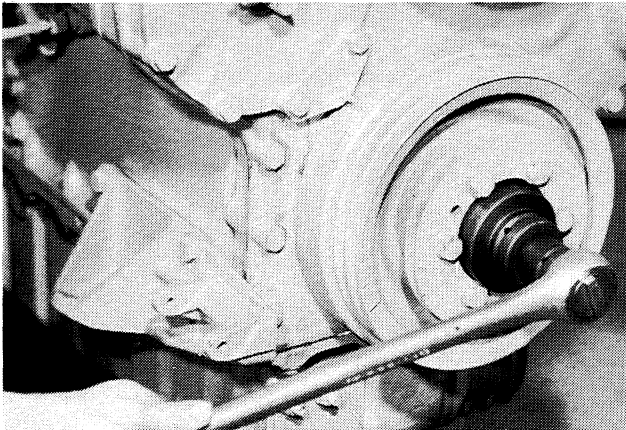

Crank the engine until timing pointer is aligned with TDC No. 1 cylinder compression stroke (push rod loose). **IMPORTANT:** The valve tappets must be properly adjusted before valve timing can be checked.

STEP 23

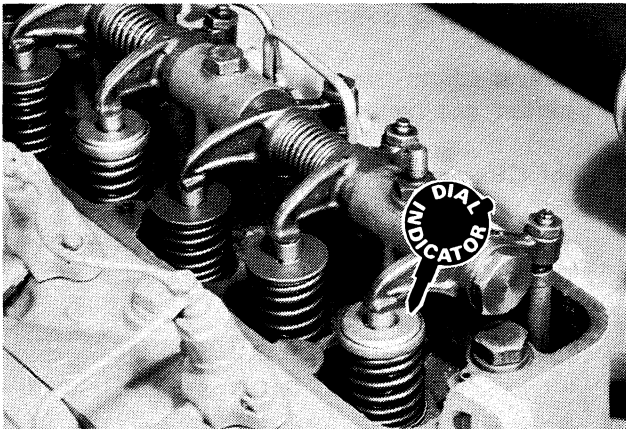

Place a dial indicator on the No. 1 intake valve retainer and set the dial indicator at zero (0).

STEP 24

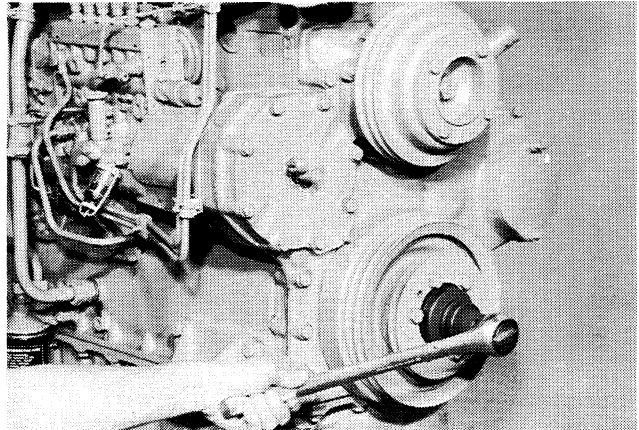

Crank engine clockwise one revolution. The dial indicator should give a reading of 2.1mm to 3.1mm. If this reading is not obtained then the complete valve train assembly must be checked.

NOTE: This procedure can be also used to check the proper assembly of cam to crankshaft gear teeth without removing the front timing gear cover.

STEP 25

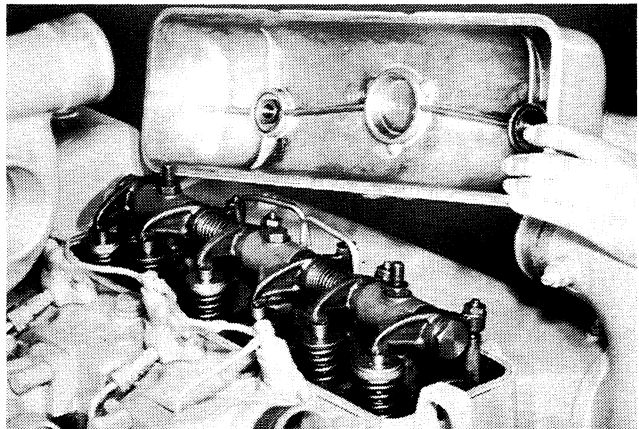

Replace the rocker arm valve covers.

Checking Nozzel Spray Pattern

STEP 26

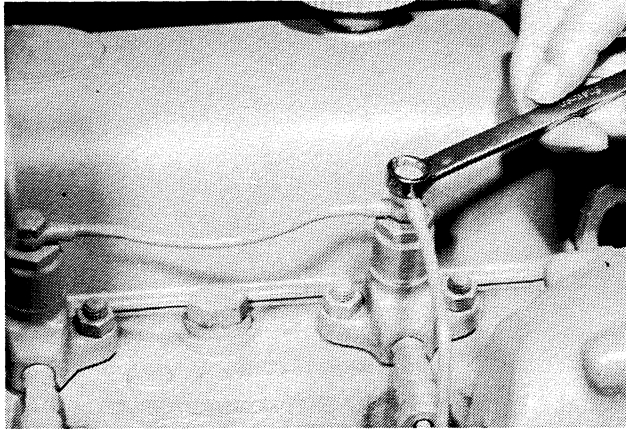

Remove the fuel supply and return lines to the injectors.

STEP 27

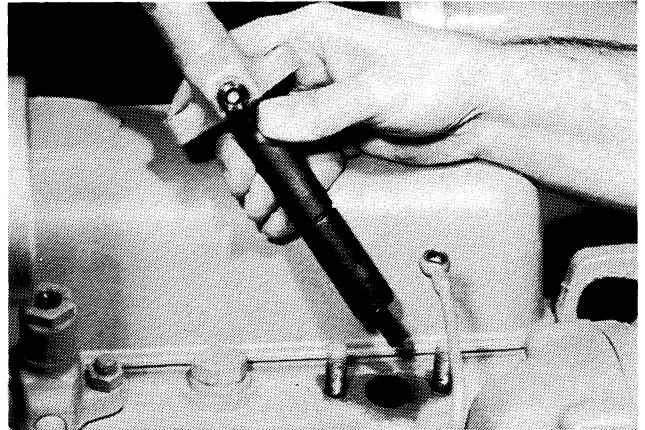

Remove and test each fuel injector, refer to Section 3113 for specifications and testing procedure. *NOTE:* A compression test should be performed on each cylinder before injectors are reinstalled.

Compression Check

STEP 28

There are two methods of checking compression pressure - the cranking method and the engine running method. The engine must be at operating temperature for either method used.

A. Cranking Method - Remove all fuel injectors.

B. Running Method - Disconnect high pressure fuel line and leakoff line from No. 1 fuel injector. Route fuel from these lines back to fuel tank or into a clean container. Repeat for each cylinder.



CAUTION Before cranking engine, make sure all operating controls are in neutral, brakes are set and wheels are securely blocked.

STEP 29

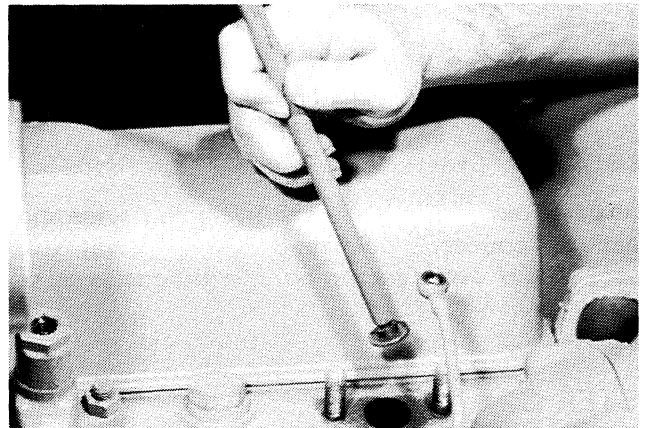

Remove the injector sealing washer, see Page 4 for extractor specifications.

STEP 30

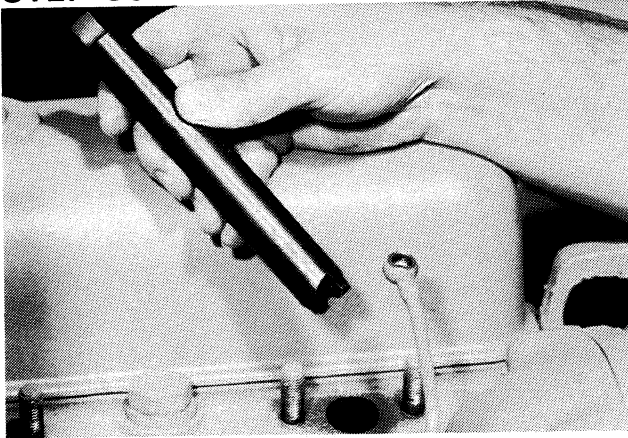

Install carbon reamer tool CAS-1003 in injector bore.

STEP 33

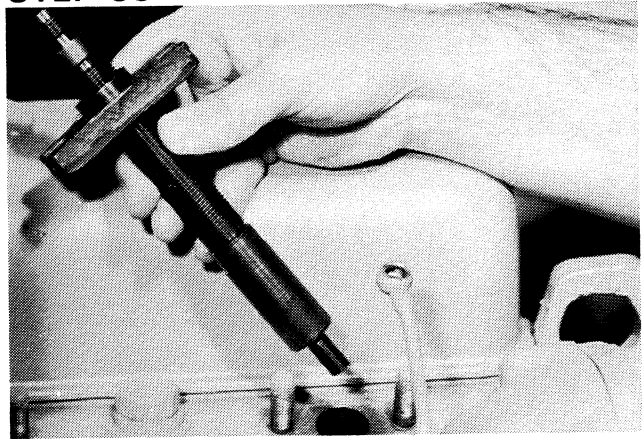

Install Bacharach 70-301 compression gauge adapter, see Page 3.

STEP 31

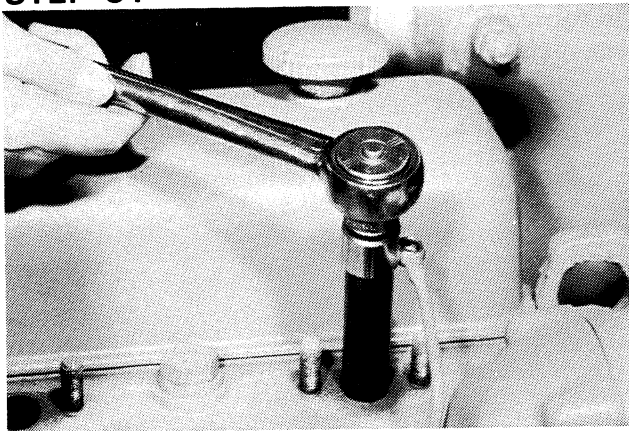

Always turn carbon reamer in a clockwise direction, counter-clockwise direction will dull tool. Blow out injector bore with compressed air.

STEP 34

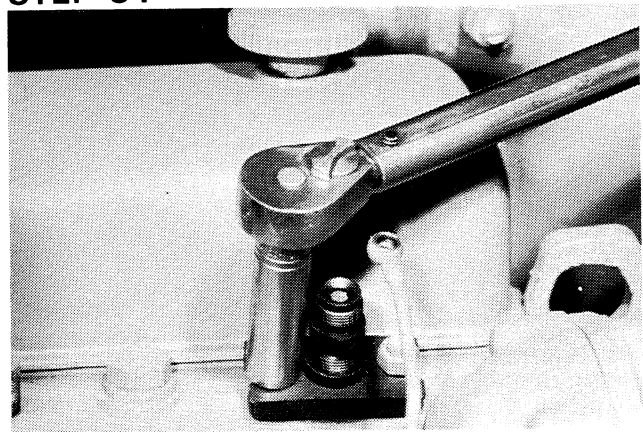

Torque adapter in place with injector retainer nuts to 7 ft. lbs.

STEP 32

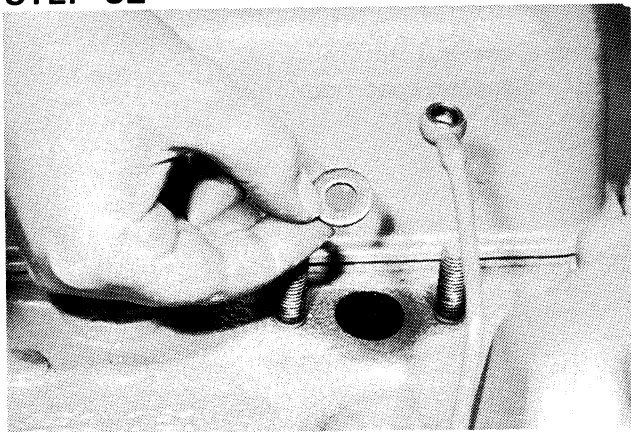

Install a new injector sealing washer in head bore.

STEP 35

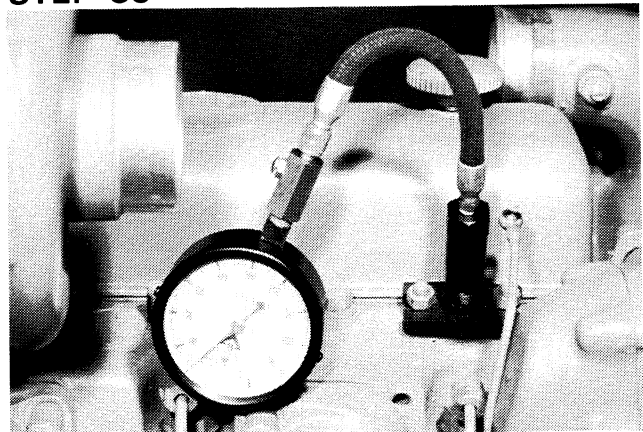

Install Bacharach 70-003 compression gauge to adapter.

STEP 36

NOTE: Take several compression readings on each cylinder using the vent valve button to relieve gauge pressure.

NOTE: When checking compression using the cranking method, start at No. 1 cylinder and continue on down the line (No. 2, 3, 4 etc.). Then, recheck No. 1 cylinder after completing the last cylinder since compression may vary due to battery run-down.

It is very important that all cylinder pressures be approximately the same. See chart for allowable compression pressure variation.

If compression is greater than normal, carbon deposits are indicated. If compression is below normal, leaking valves or excessive ring clearance is indicated.

NOTE: To make a simple test when a compression leak is indicated, squirt a teaspoon of oil into cylinder and recheck compression. If pressure rises to near normal, compression loss is past the rings. Very little change in compression indicates leakage is past the valves.

	ENGINE SPEED	NORMAL COMPRESSION PRESSURE	ALLOWABLE VARIATION BETWEEN CYLINDERS
CRANKING	APPROXIMATELY 200 RPM UNTIL COMPRESSION GAUGE STABILIZES	400 PSI*	25 PSI
RUNNING	800 RPM	480 PSI*	20 PSI
*NOTE: A 4% REDUCTION IN PSI MUST BE ALLOWED FOR EVERY 1000 FT. ABOVE SEA LEVEL.			

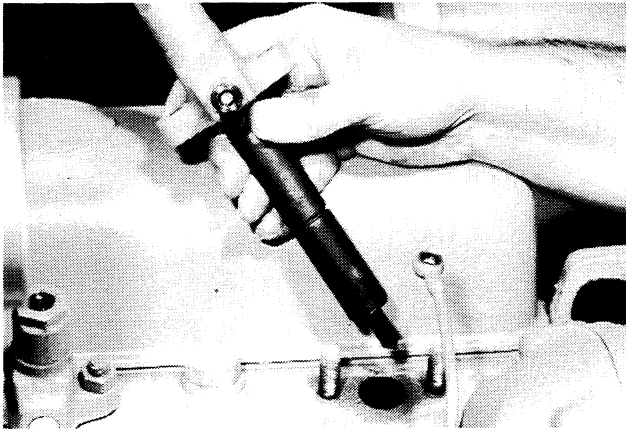
STEP 37

Reinstall fuel injectors, refer to Section 3113.

Cleaning and Servicing Air Intake System

STEP 38

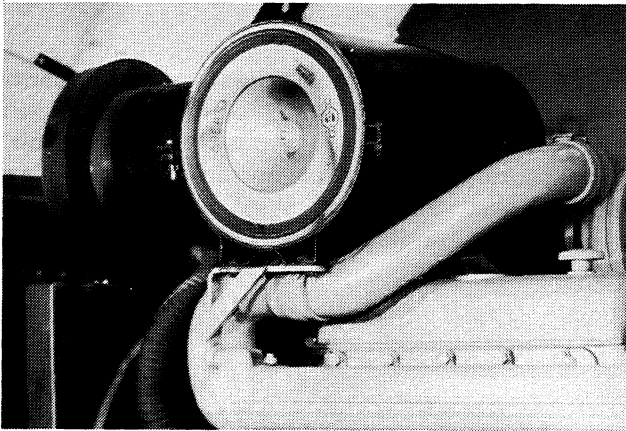

Inspect and service the air intake system, refer to Section 2175 of this manual for servicing the air intake system.

Cleaning and Servicing Fuel Filters

STEP 39

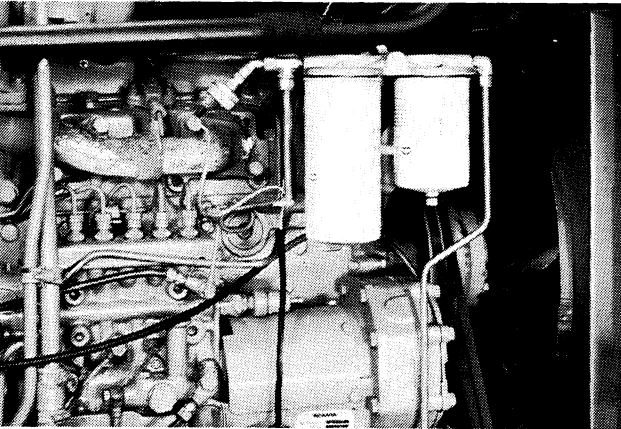

Refer to Section 3110 for cleaning and servicing the fuel filters and system.

Retiming Injection Pump

STEP 40

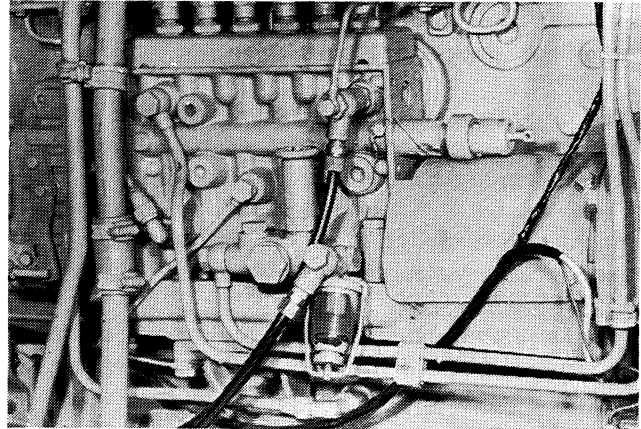

Refer to Section 3112 for checking and adjusting fuel pump timing.

Checking Engine Governed Speed

STEP 41

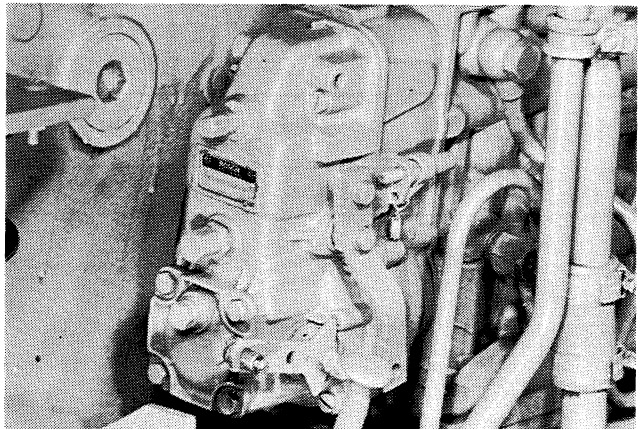

Refer to Section 3112 for checking and adjusting the engine governed speed.



Suggest:

If the above button click is invalid.

Please download this document

first, and then click the above link

to download the complete manual.

Thank you so much for reading

Fan Belt Adjustment

STEP 42

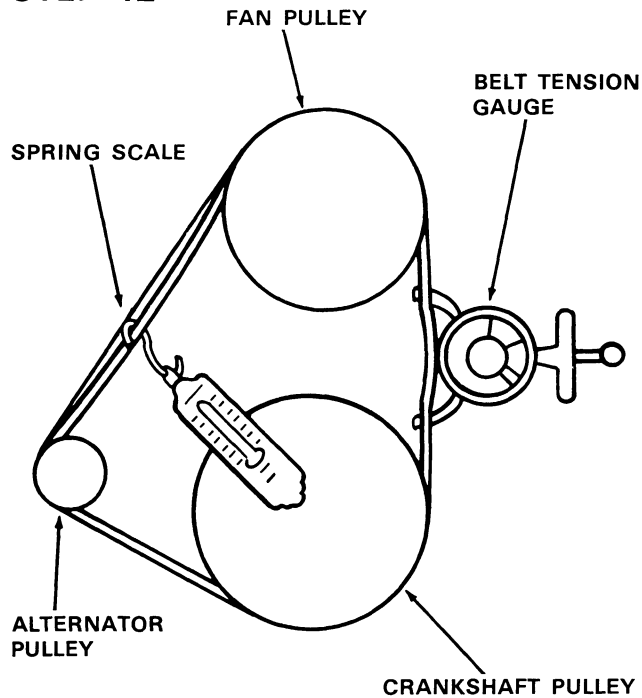

Measure the fan belts for proper tension or deflection using a belt tension gauge or a spring scale. **NOTE:** When using a spring scale, the measurement must be made at the mid point between the fan and alternator pulleys.

Belt tension must be 60 lbs. (267N) per belt when using a belt tension gauge. **DO NOT** exceed a combined tension of 120 lbs. (534N) on the belts.

Belt deflection must be .39" (10mm) per belt when using a spring scale.

NOTE: Excessive tension will cause alternator and water pump bearing failure and extreme belt wear. Insufficient tension will cause low or no alternator output and excessive belt wear.

STEP 43

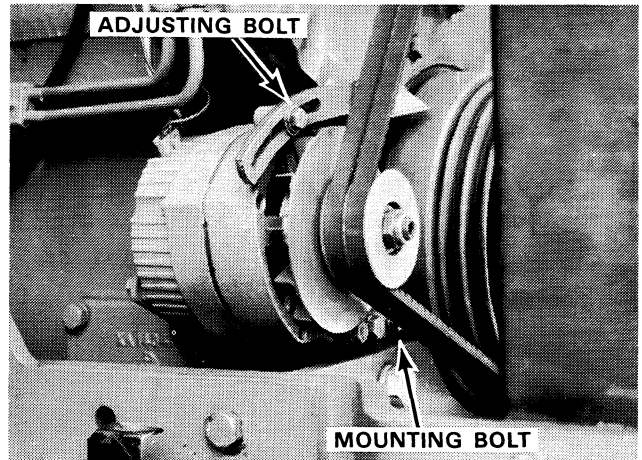

Loosen alternator adjusting and mounting bolts. Pull outward on alternator and retighten bolts, then recheck belt tension or deflection as outlined in Step 42.

To replace fan belts, swing alternator inward toward engine. Remove old belts, slip new belts over fan and onto fan pulley, then onto crankshaft and alternator pulleys. Tighten new belts to 70 lbs. (311N) tension per belt. **NOTE:** Readjust new belts to 60 lbs. (267N) tension per belt after the first 15 minutes of operation.

NOTE: If the tractor is equipped with air conditioning, refer to air conditioning section of this service manual for compressor belt adjustment.

<https://www.ebooklibonline.com>

Hello dear friend!

Thank you very much for reading.

Enter the link into your browser.

The full manual is available for immediate download.

<https://www.ebooklibonline.com>