

580N
580SN WT
580SN
590SN
Tier 4B (final)
Tractor Loader Backhoe

*580N PIN NGC730186 and above; 580SN WT PIN NGC735098 and above;
580SN PIN NGC732639 and above; 590SN PIN NGC736228 and above*

SERVICE MANUAL

Part number 48038048

1st edition English

October 2016

CASE
CONSTRUCTION



SERVICE MANUAL

**580N FOUR-WHEEL DRIVE (4WD) TIER 4B (FINAL) [NGC730186 -], 580N
TWO-WHEEL DRIVE (2WD) TIER 4B (FINAL) [NGC730186 -], 580SN
FOUR-WHEEL DRIVE (4WD) TIER 4B (FINAL) [NGC732639 -], 580SN
TWO-WHEEL DRIVE (2WD) TIER 4B (FINAL) [NGC732639 -], 580SN WT
FOUR-WHEEL DRIVE (4WD) TIER 4B (FINAL) [NGC735098 -], 590SN
FOUR-WHEEL DRIVE (4WD) TIER 4B (FINAL) [NGC736228 -], 590SN
TWO-WHEEL DRIVE (2WD) TIER 4B (FINAL) [NGC736228 -]**

Link Product / Engine

Product	Market Product	Engine
580N TWO-WHEEL DRIVE (2WD) TIER 4B (FINAL) [NGC730186 -]	North America	F5BFL413A*B007
580N FOUR-WHEEL DRIVE (4WD) TIER 4B (FINAL) [NGC730186 -]	North America	F5BFL413A*B007
580SN TWO-WHEEL DRIVE (2WD) TIER 4B (FINAL) [NGC732639 -]	North America	F5BFL413A*B007
580SN FOUR-WHEEL DRIVE (4WD) TIER 4B (FINAL) [NGC732639 -]	North America	F5BFL413A*B007
580SN WT FOUR-WHEEL DRIVE (4WD) TIER 4B (FINAL) [NGC735098 -]	North America	F5BFL413A*B007
590SN TWO-WHEEL DRIVE (2WD) TIER 4B (FINAL) [NGC736228 -]	North America	F5BFL413A*B007
590SN FOUR-WHEEL DRIVE (4WD) TIER 4B (FINAL) [NGC736228 -]	North America	F5BFL413A*B007

<https://www.ebooklibonline.com>

Hello dear friend!

Thank you very much for reading.

Enter the link into your browser.

The full manual is available for immediate download.

<https://www.ebooklibonline.com>

Contents

INTRODUCTION

Engine	10
[10.001] Engine and crankcase	10.1
[10.206] Fuel filters	10.2
[10.216] Fuel tanks	10.3
[10.218] Fuel injection system.....	10.4
[10.304] Engine lubrication system.....	10.5
[10.400] Engine cooling system	10.6
[10.414] Fan and drive	10.7
[10.500] Selective Catalytic Reduction (SCR) exhaust treatment.....	10.8
Transmission	21
[21.112] Power shuttle transmission.....	21.1
[21.113] Powershift transmission	21.2
[21.134] Power shuttle transmission external controls	21.3
[21.135] Powershift transmission external controls.....	21.4
[21.154] Power shuttle transmission internal components	21.5
[21.155] Powershift transmission internal components.....	21.6
Front axle system	25
[25.100] Powered front axle	25.1
[25.102] Front bevel gear set and differential	25.2
[25.108] Final drive hub, steering knuckles, and shafts	25.3
[25.400] Non-powered front axle	25.4
Rear axle system	27
[27.100] Powered rear axle.....	27.1
[27.106] Rear bevel gear set and differential	27.2
[27.120] Planetary and final drives	27.3

Brakes and controls	33
[33.110] Parking brake or parking lock	33.1
[33.202] Hydraulic service brakes	33.2
Hydraulic systems.....	35
[35.000] Hydraulic systems.....	35.1
[35.102] Pump control valves.....	35.2
[35.104] Fixed displacement pump.....	35.3
[35.106] Variable displacement pump	35.4
[35.204] Remote control valves	35.5
[35.300] Reservoir, cooler, and filters.....	35.6
[35.350] Safety and main relief valves	35.7
[35.357] Pilot system	35.8
[35.359] Main control valve.....	35.9
[35.525] Auxiliary hydraulic valves and lines	35.10
[35.701] Front loader arm hydraulic system.....	35.11
[35.703] Stabilizer hydraulic system.....	35.12
[35.723] Front loader bucket hydraulic system.....	35.13
[35.726] Excavator and backhoe hydraulic controls.....	35.14
[35.736] Boom hydraulic system	35.15
[35.737] Dipper hydraulic system.....	35.16
[35.738] Excavator and backhoe bucket hydraulic system.....	35.17
[35.739] Swing arm hydraulic system	35.18
[35.740] Telescopic arm hydraulic system.....	35.19
Frames and ballasting	39
[39.100] Frame	39.1
[39.129] Stabilizers	39.2
Steering.....	41
[41.101] Steering control	41.1

[41.200] Hydraulic control components.....	41.2
[41.216] Cylinders.....	41.3
Wheels.....	44
[44.511] Front wheels.....	44.1
[44.520] Rear wheels.....	44.2
Cab climate control.....	50
[50.200] Air conditioning.....	50.1
Electrical systems.....	55
[55.024] Transmission control system.....	55.1
[55.100] Harnesses and connectors.....	55.2
[55.201] Engine starting system.....	55.3
[55.301] Alternator.....	55.4
[55.302] Battery.....	55.5
[55.404] External lighting.....	55.6
[55.408] Warning indicators, alarms, and instruments.....	55.7
[55.510] Cab or platform harnesses and connectors.....	55.8
[55.640] Electronic modules.....	55.9
[55.988] Selective Catalytic Reduction (SCR) electrical system.....	55.10
[55.991] Telematics.....	55.11
[55.DTC] FAULT CODES.....	55.12
Front loader and bucket.....	82
[82.100] Arm.....	82.1
[82.300] Bucket.....	82.2
Booms, dippers, and buckets.....	84
[84.100] Bucket.....	84.1
[84.114] Boom pivoting support.....	84.2
[84.910] Boom.....	84.3
[84.912] Dipper arm.....	84.4

Platform, cab, bodywork, and decals	90
[90.100] Engine hood and panels	90.1
[90.114] Operator protections	90.2
[90.124] Pneumatically-adjusted operator seat.....	90.3
[90.150] Cab.....	90.4
[90.151] Cab interior.....	90.5
[90.154] Cab doors and hatches	90.6



INTRODUCTION

Foreword - Important notice regarding equipment servicing

All repair and maintenance work listed in this manual must be carried out only by qualified dealership personnel, strictly complying with the instructions given, and using, whenever possible, the special tools.

Anyone who performs repair and maintenance operations without complying with the procedures provided herein shall be responsible for any subsequent damages.

The manufacturer and all the organizations of its distribution chain, including - without limitation - national, regional, or local dealers, reject any responsibility for damages caused by parts and/or components not approved by the manufacturer, including those used for the servicing or repair of the product manufactured or marketed by the manufacturer. In any case, no warranty is given or attributed on the product manufactured or marketed by the manufacturer in case of damages caused by parts and/or components not approved by the manufacturer.

The manufacturer reserves the right to make improvements in design and changes in specifications at any time without notice and without incurring any obligation to install them on units previously sold. Specifications, descriptions, and illustrative material herein are as accurate as known at time of publication but are subject to change without notice.

In case of questions, refer to your CASE CONSTRUCTION Sales and Service Networks.

Safety rules

Personal safety





This is the safety alert symbol. It is used to alert you to potential personal injury hazards. Obey all safety messages that follow this symbol to avoid possible death or injury.

Throughout this manual you will find the signal words DANGER, WARNING, and CAUTION followed by special instructions. These precautions are intended for the personal safety of you and those working with you.

Read and understand all the safety messages in this manual before you operate or service the machine.

 DANGER indicates a hazardous situation that, if not avoided, will result in death or serious injury.

 WARNING indicates a hazardous situation that, if not avoided, could result in death or serious injury.

 CAUTION indicates a hazardous situation that, if not avoided, could result in minor or moderate injury.

FAILURE TO FOLLOW DANGER, WARNING, AND CAUTION MESSAGES COULD RESULT IN DEATH OR SERIOUS INJURY.

Machine safety

NOTICE: Notice indicates a situation that, if not avoided, could result in machine or property damage.

Throughout this manual you will find the signal word Notice followed by special instructions to prevent machine or property damage. The word Notice is used to address practices not related to personal safety.

Information

NOTE: Note indicates additional information that clarifies steps, procedures, or other information in this manual.

Throughout this manual you will find the word Note followed by additional information about a step, procedure, or other information in the manual. The word Note is not intended to address personal safety or property damage.

Safety rules - Personal safety

Unless otherwise instructed, always perform these steps before you service the machine:

1. Park the machine on a flat, level surface.
2. Place the backhoe in the transport position with the swing lock pin installed for transport.
3. Place the loader bucket on the ground, with the bottom of the loader bucket parallel to the surface.
4. Place the direction control lever and the transmission in neutral.
5. If you need to open the hood to perform service, raise the loader arms and install the support strut.
6. Shut down the engine.
7. Place a 'Do Not Operate' tag on the key switch so that it is visible to other workers or remove the key.

Safety rules - Ecology and the environment

Soil, air, and water quality is important for all industries and life in general. When legislation does not yet rule the treatment of some of the substances that advanced technology requires, sound judgment should govern the use and disposal of products of a chemical and petrochemical nature.

Familiarize yourself with the relative legislation applicable to your country, and make sure that you understand this legislation. Where no legislation exists, obtain information from suppliers of oils, filters, batteries, fuels, anti-freeze, cleaning agents, etc., with regard to the effect of these substances on man and nature and how to safely store, use, and dispose of these substances.

Helpful hints

- Avoid the use of cans or other inappropriate pressurized fuel delivery systems to fill tanks. Such delivery systems may cause considerable spillage.
- In general, avoid skin contact with all fuels, oils, acids, solvents, etc. Most of these products contain substances that may be harmful to your health.
- Modern oils contain additives. Do not burn contaminated fuels and or waste oils in ordinary heating systems.
- Avoid spillage when you drain fluids such as used engine coolant mixtures, engine oil, hydraulic fluid, brake fluid, etc. Do not mix drained brake fluids or fuels with lubricants. Store all drained fluids safely until you can dispose of the fluids in a proper way that complies with all local legislation and available resources.
- Do not allow coolant mixtures to get into the soil. Collect and dispose of coolant mixtures properly.
- The air-conditioning system contains gases that should not be released into the atmosphere. Consult an air-conditioning specialist or use a special extractor to recharge the system properly.
- Repair any leaks or defects in the engine cooling system or hydraulic system immediately.
- Do not increase the pressure in a pressurized circuit as this may lead to a component failure.
- Protect hoses during welding. Penetrating weld splatter may burn a hole or weaken hoses, allowing the loss of oils, coolant, etc.

Battery recycling

Batteries and electric accumulators contain several substances that can have a harmful effect on the environment if the batteries are not properly recycled after use. Improper disposal of batteries can contaminate the soil, groundwater, and waterways. CASE CONSTRUCTION strongly recommends that you return all used batteries to a CASE CONSTRUCTION dealer, who will dispose of the used batteries or recycle the used batteries properly. In some countries, this is a legal requirement.



Mandatory battery recycling

NOTE: The following requirements are mandatory in Brazil.

Batteries are made of lead plates and a sulfuric acid solution. Because batteries contain heavy metals such as lead, CONAMA Resolution 401/2008 requires you to return all used batteries to the battery dealer when you replace any batteries. Do not dispose of batteries in your household garbage.

Points of sale are obliged to:

- Accept the return of your used batteries
- Store the returned batteries in a suitable location
- Send the returned batteries to the battery manufacturer for recycling

Part identification

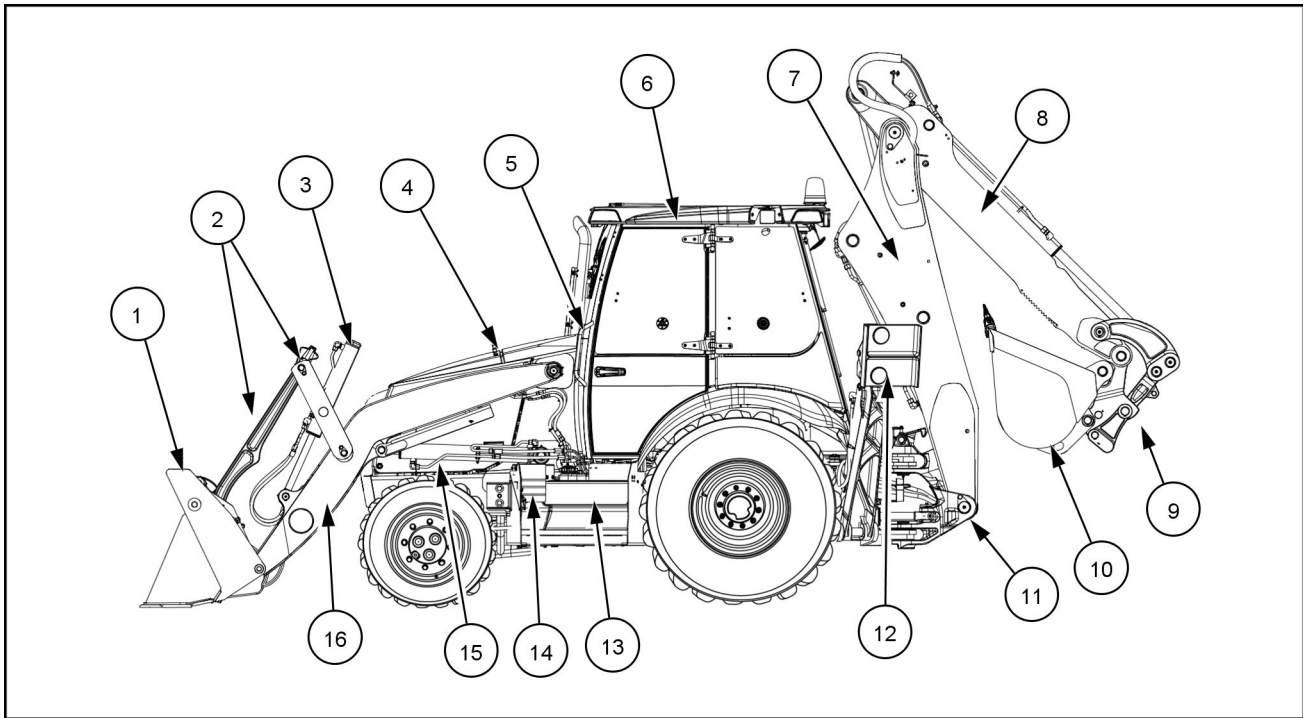

RAIL14TLB0971FA 1

- | | |
|---|---|
| <p>(1) Loader bucket (4-in-1 bucket shown)</p> <p>(2) Loader bucket links</p> <p>(3) Bucket cylinders</p> <p>(4) Engine hood latch</p> <p>(5) Hand hold</p> <p>(6) Cab (canopy not shown)</p> | <p>(9) Universal backhoe coupler (optional)</p> <p>(10) Backhoe bucket</p> <p>(11) Swing tower</p> <p>(12) Stabilizer (shown in transport position)</p> <p>(13) Fuel tank with entry step and optional locking cover</p> <p>(14) Diesel Exhaust Fluid (DEF) –DEF/AdBlue® tank with optional locking cover</p> <p>(15) Loader arm lift cylinder with support strut</p> <p>(16) Loader arm</p> |
| <p>(7) Boom</p> <p>(8) Dipper</p> | |

INTRODUCTION

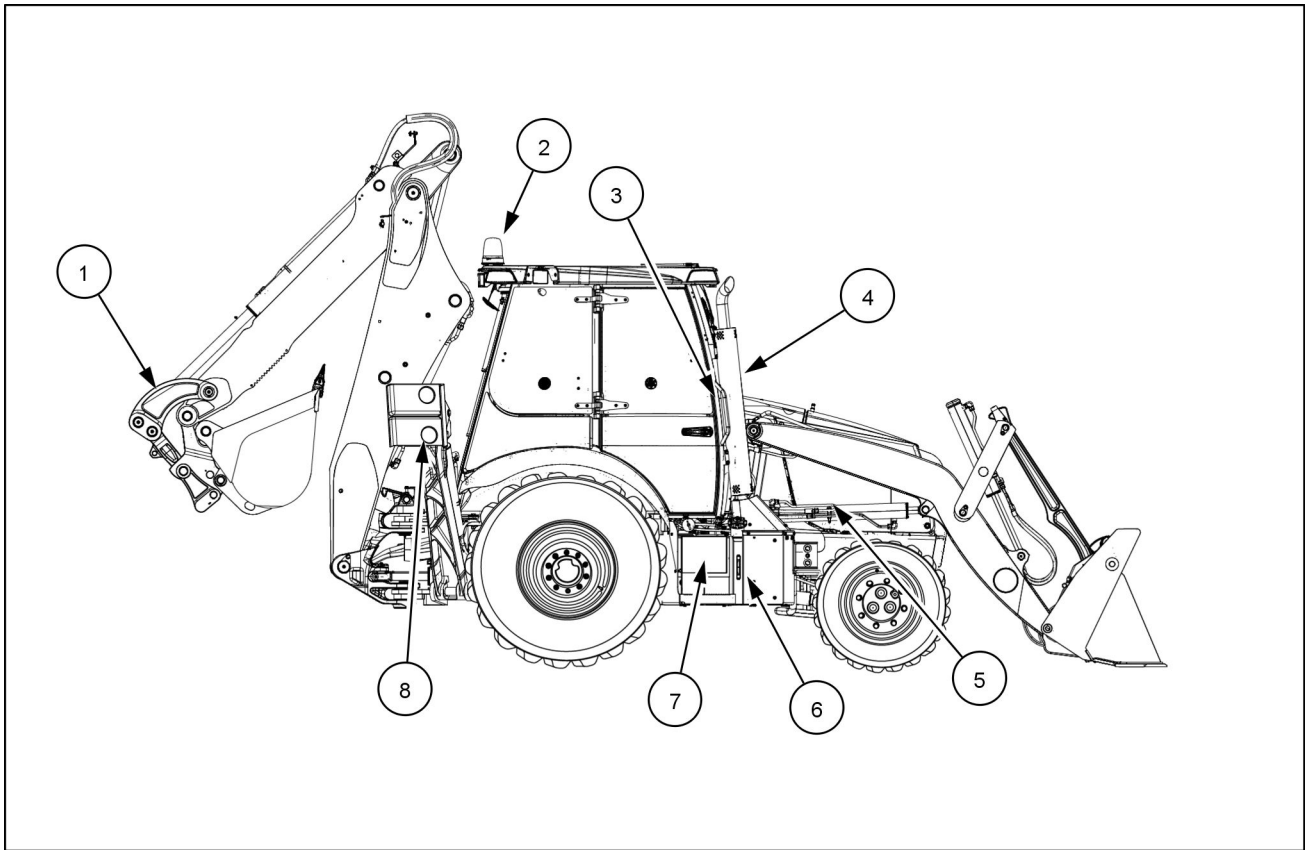

RAIL14TLB0972FA 2

- (1) Backhoe bucket coupler links
- (2) Beacon
- (3) Hand hold
- (4) Exhaust stack
- (5) Master disconnect switch under the engine hood (optional)
- (6) Hydraulic tank sight gauge
- (7) Battery compartment with optional tool box
- (8) Stabilizer (shown in transport position)



SERVICE MANUAL

Engine

**580N FOUR-WHEEL DRIVE (4WD) TIER 4B (FINAL) [NGC730186 -], 580N
TWO-WHEEL DRIVE (2WD) TIER 4B (FINAL) [NGC730186 -], 580SN
FOUR-WHEEL DRIVE (4WD) TIER 4B (FINAL) [NGC732639 -], 580SN
TWO-WHEEL DRIVE (2WD) TIER 4B (FINAL) [NGC732639 -], 580SN WT
FOUR-WHEEL DRIVE (4WD) TIER 4B (FINAL) [NGC735098 -], 590SN
FOUR-WHEEL DRIVE (4WD) TIER 4B (FINAL) [NGC736228 -], 590SN
TWO-WHEEL DRIVE (2WD) TIER 4B (FINAL) [NGC736228 -]**

Engine - Engine and crankcase

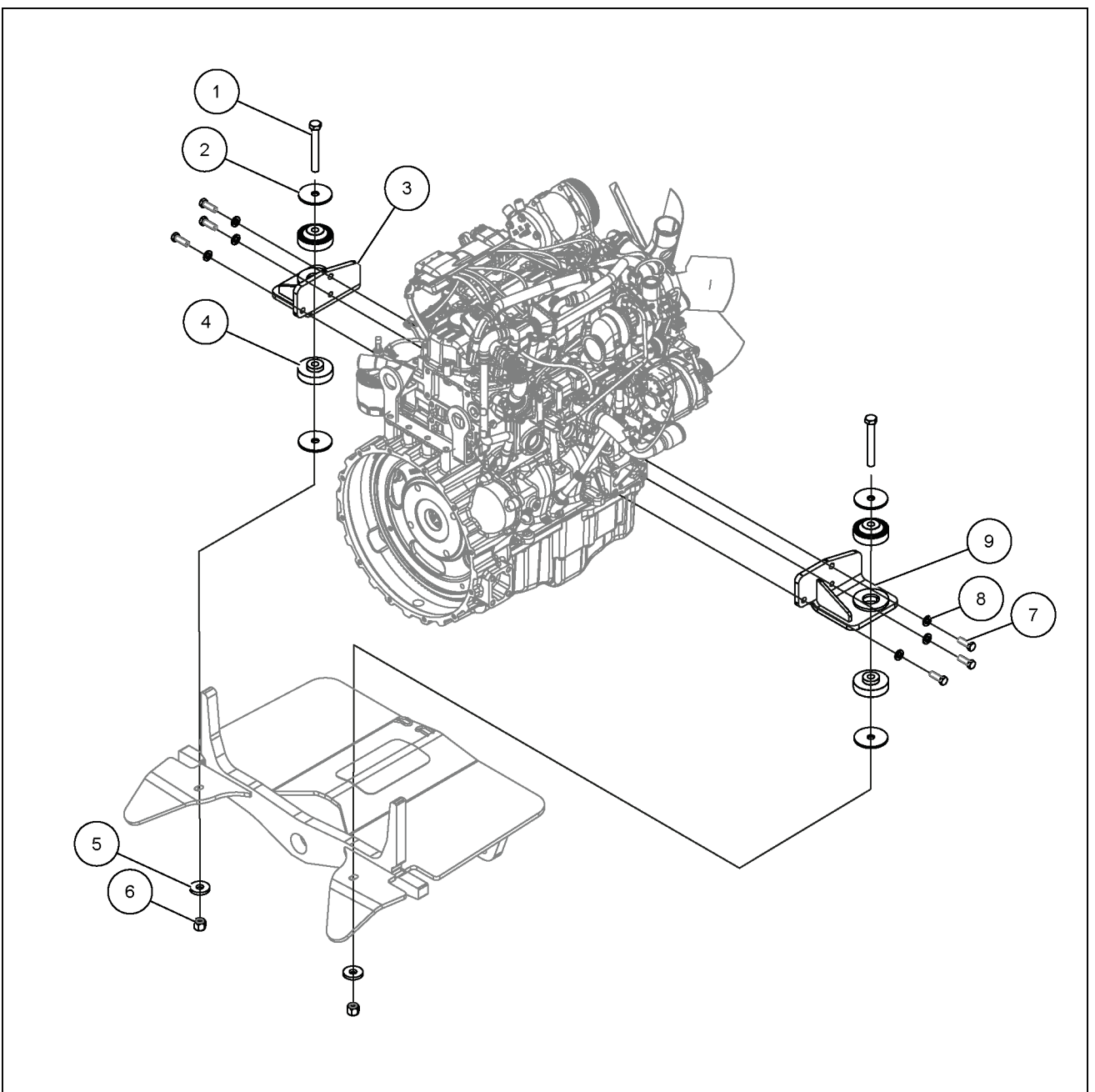

RAIL12UTL0338GA 1

Engine - Prepare - Stall tests

Do the stall test to find the cause of poor performance.

The main relief valve must be set within specifications to achieve accurate readings when performing the following stall tests.

The engine is run at full throttle and the transmission and hydraulic systems are engaged separately, and then together.

Comparing the engine speeds from the stall test with the check sheets in this section will help to find the cause of the problem. It can be necessary to check a separate system to find the exact cause of the problem.

Use a photo tachometer or other tachometer of equal accuracy to get accurate results from the stall test.

The engine, transmission and hydraulic system must be at operating temperature before doing the stall test. Heat the oil according to instructions in this section.

Machines with standard transmission

1. Apply the parking brake.
2. Move the transmission gear selector into fourth gear.
3. Lock the brake pedals together. Put your foot on the service brakes and hold the machine with service brakes.
4. Release the parking brake.
5. With the engine running at low idle, move the direction control lever forward.
6. Slowly increase the engine speed to full throttle.
7. If the machine begins to move at any time, decrease the engine speed to low idle and stop the engine.

Machines with S-Type and H-Type transmissions

1. Apply the parking brake.
2. Place the automatic/manual switch in the manual position.
3. Select fourth gear on the range selector.
4. Lock the brake pedals together. Put your foot on the service brakes and hold the machine with service brakes.
5. Release the parking brake.
6. With the engine running at low idle, move the direction control lever forward.
7. Slowly increase the engine speed to full throttle.
8. If the machine begins to move at any time, decrease the engine speed to low idle and stop the engine. Refer to sections **Parking brake discs - Inspect (33.110)**, **Parking brake discs - Test (33.110)** and **Parking brake discs - Check (33.110)**.

Procedure to heat the torque converter and the hydraulic oil

1. Apply the parking brake.
2. Start and run the engine at low idle.
3. Run the engine at full throttle, hold the loader control lever in the rollback position for 15 seconds.
4. Return the loader control lever to neutral for 15 seconds.
5. Return the boom control lever to neutral for 15 seconds.
6. Repeat steps 3 and 4 until the temperature of the oil is **52 °C (126 °F)**. The side of the reservoir will be very warm at this temperature.
7. With the engine running at low idle, move the transmission control to fourth gear and the direction control lever to forward.
8. Run the engine at full throttle for 15 seconds.
9. Decrease the engine speed to low idle and move the direction control lever to neutral for 15 seconds.
10. Repeat steps 6 through 8 until the pointer in the gauge for transmission oil temperature is in the center of the green zone of the gauge for transmission oil temperature.

Stall test procedure

1. Prepare the machine for the stall test according to instructions in this section.
2. Heat the oil according to instructions in this section.
3. Apply the parking brake and start the engine.
4. With the engine running at full throttle, hold the loader control lever in the lift position and read the tachometer. Record the reading on line 1 of the check sheet.
5. With the engine running at full throttle and boom in travel lock, hold the dipper lever in the in position and read the tachometer. Record the reading on line 2 of the check sheet.
6. Decrease the engine speed to low idle.
7. Move the transmission control lever to fourth gear.

NOTE: For machines with S-Type and H-Type transmissions, place the automatic/manual switch in the manual position.

8. Lock the brake pedals together. Put your foot on the service brakes and hold the machine with service brakes.
9. Release the parking brake.
10. Move the direction control lever to forward.
11. Slowly increase the engine speed to full throttle and read the tachometer. Record the reading on line 3 on the check sheet.

12. With the transmission control lever in fourth gear, the direction control lever in forward, and the engine running at full throttle, hold the loader control lever in the lift position and read the tachometer. Record the reading on line 4 on the check sheet.
13. Decrease the engine speed to low idle, move the directional control lever to neutral.
14. Run the engine at low idle for two minutes and then stop the engine.
15. See the check sheet to understand the results of the stall test.

Engine - Remove

⚠ DANGER

Crushing hazard!

If you service the machine with the loader lift arms raised, always use the support strut. Remove the retaining pin and place the support strut onto the cylinder rod. Install the retaining pin into the support strut. Lower the lift arms onto the support strut.

Failure to comply will result in death or serious injury.

D0084A

⚠ WARNING

Heavy objects!

Lift and handle all heavy components using lifting equipment with adequate capacity. Always support units or parts with suitable slings or hooks. Make sure the work area is clear of all bystanders.

Failure to comply could result in death or serious injury.

W0398A

NOTICE: Avoid contamination always clean all surrounding areas before disconnecting components. Always cap or plug all tubes, hoses, and component openings after disconnecting or removal.

NOTICE: Attach identification labels to all connectors, tubes, and hoses to help with the installation procedure.

Prior operation:

Disconnect the batteries. See **Battery - Disconnect (55.302)**.

Prior operation:

Drain the hydraulic tank. See **Oil reservoir - Drain fluid (35.300)**.

Prior operation:

Drain the transmission fluid. For Powershuttle transmissions see **Power shuttle transmission - Drain fluid (21.112)**. For Powershift transmissions see **Powershift transmission - Drain fluid (21.113)**.

Prior operation:

Remove the engine hood. See **Hood - Remove (90.105)**.

Prior operation:

Drain the cooling system. See **Radiator - Drain fluid (10.400)**.

Prior operation:

If applicable, discharge the Air-Conditioning (A/C) system. See **Air conditioning - Charging (50.200)**. Do not follow the charge system procedure.

1. Remove the bolts (3) that secure the air cleaner (2) to the fixed hood (1).

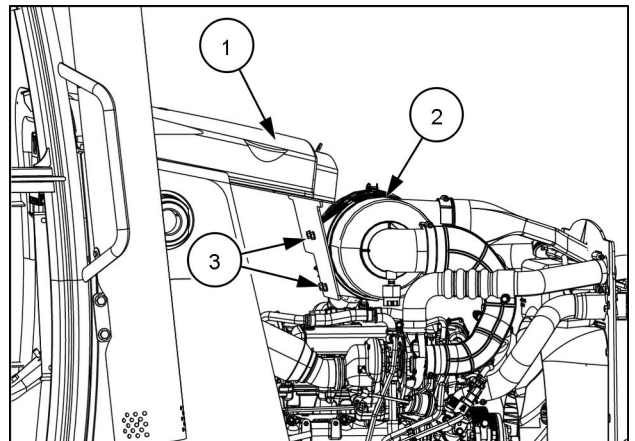

RAIL16TLB1122BA 1

2. Attach a suitable lifting device to the fixed hood (1).
3. Remove the bolts (2) and lift the fixed hood off of the machine.

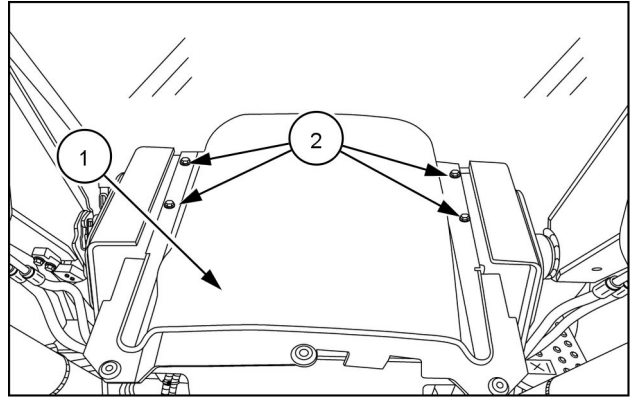

RAIL14TLB1156AA 2

4. Remove the bolts (1) from the front bumper (2).
5. Remove the front grille (3)

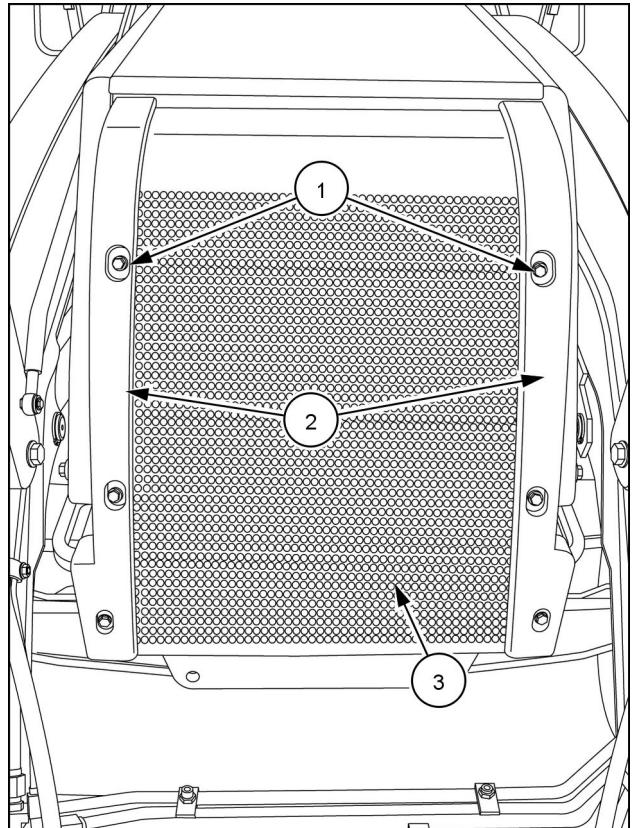

RAIL14UTL0048BA 3

6. Remove the air intake tube support bracket bolts (1) and bracket (2).

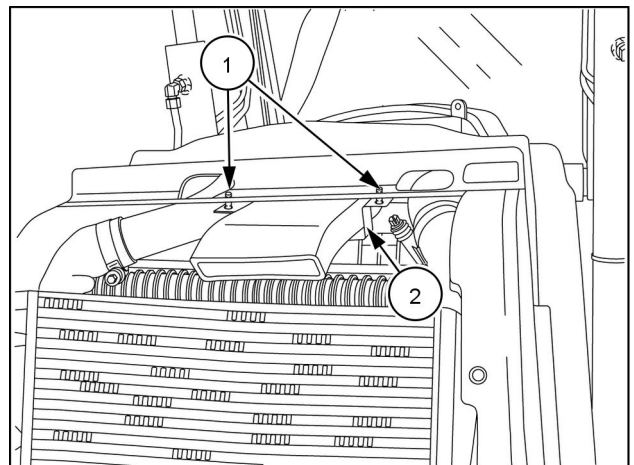

RAPH11TLB0030BA 4

7. Support the cooling package housing wrapper (1).

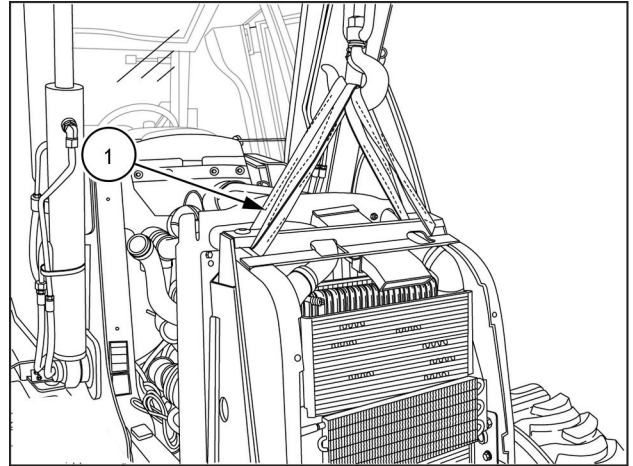

RAPH11TLB0038BA 5

8. Remove the cooling package housing wrapper bolts (1), (2).

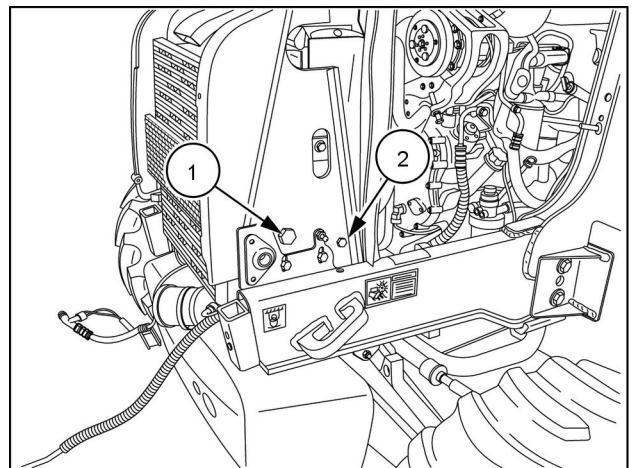

RAPH11TLB0029BA 6

9. Carefully lift and remove the cooling package housing wrapper.

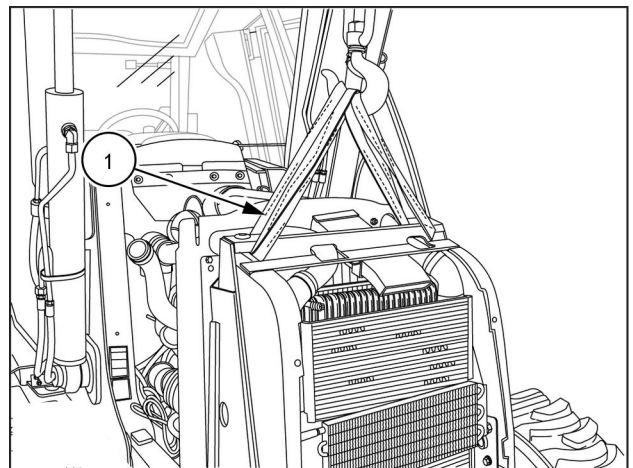

RAPH11TLB0038BA 7

10. Loosen the hose clamp **(3)** on the air cleaner outlet hose and disconnect the hose.
11. Loosen the hose clamp **(2)** on the Closed Crankcase Ventilation (CCV) hose and disconnect hose.
12. Remove all tie wraps **(1)** that secure the CCV hose position.

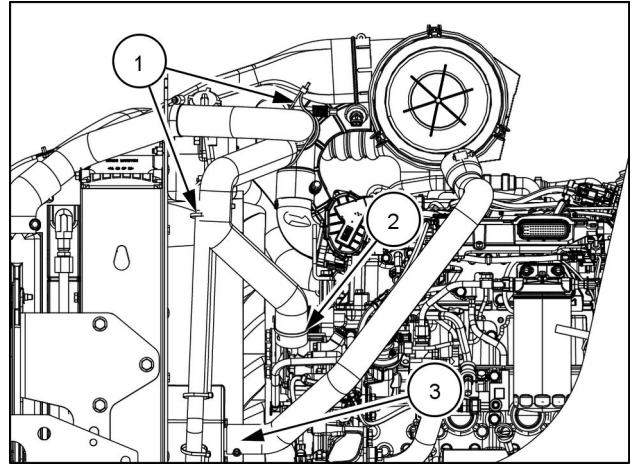

RAIL16TLB1123BA 8

13. Loosen and remove the exhaust tube clamp **(1)**.
14. Loosen the hose clamp on the air intake hose **(2)** and disconnect the hose.

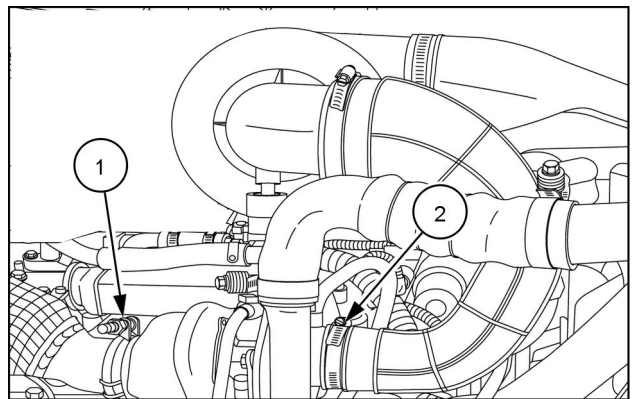

RAIL14TLB1151AA 9

15. Disconnect the air restriction sensor **(1)** wiring.

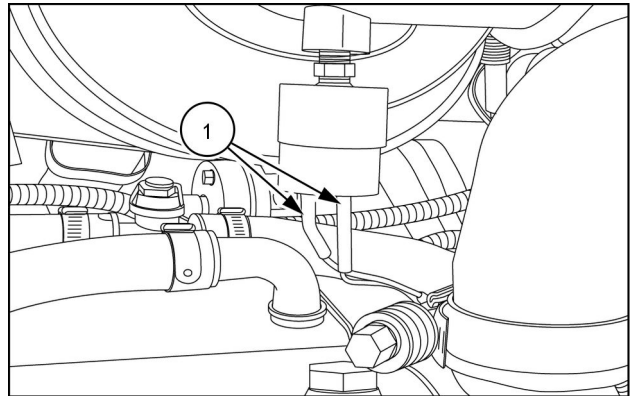

RAIL14TLB1152AA 10

16. Disconnect the temperature sensor **(1)** connector.

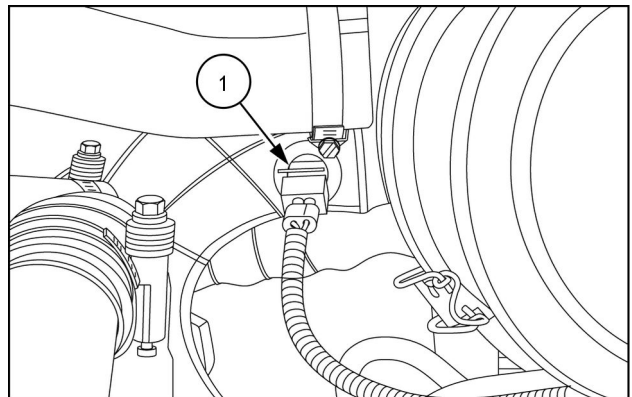

RAIL14TLB1153AA 11

17. Remove the air cleaner assembly from the machine.

18. Loosen the clamps **(2)** from the Charge-Air-Cooler (CAC) tubes **(1)**, **(3)** and disconnect tubes.

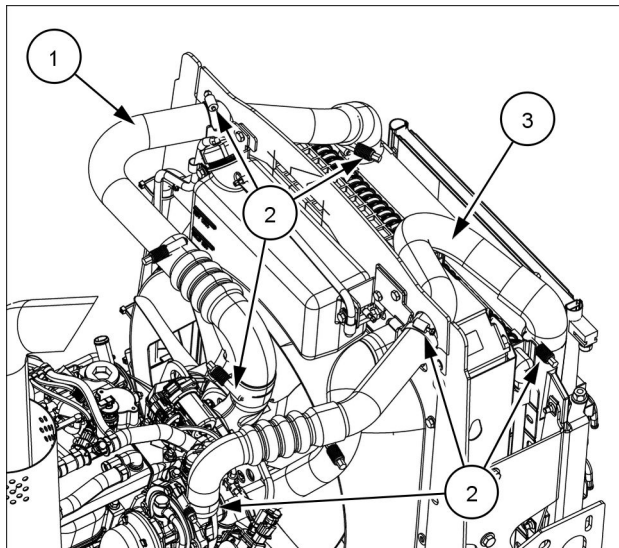

RAIL16TLB1126BA 12

19. Disconnect the A/C condenser inlet line **(1)**.
20. Disconnect the inlet fuel cooler line **(2)**.
21. Disconnect the outlet fuel cooler line **(3)**.
22. Disconnect the A/C condenser outlet line **(4)**.

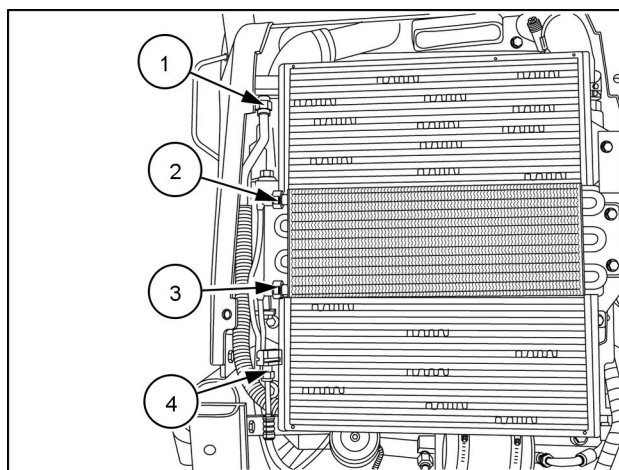

RAPH11TLB0037BA 13

23. Remove the horn bracket nut **(1)**. Place the horn and horn bracket away from the cooling package.

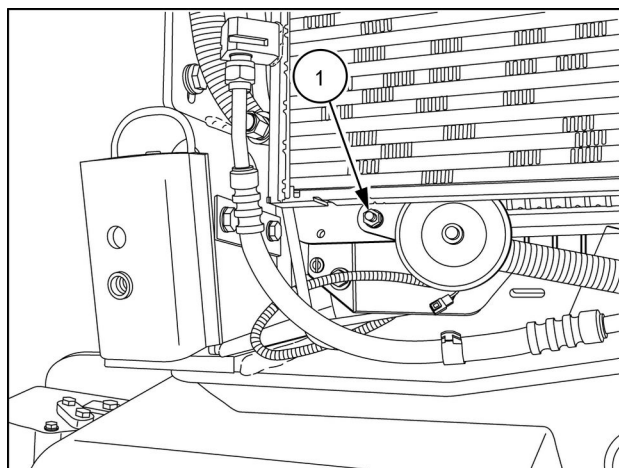

RAPH11TLB0035BA 14

24. Loosen and remove the receiver/dryer hold-down clamps **(1)**. Place the receiver/dryer away from the cooling package.

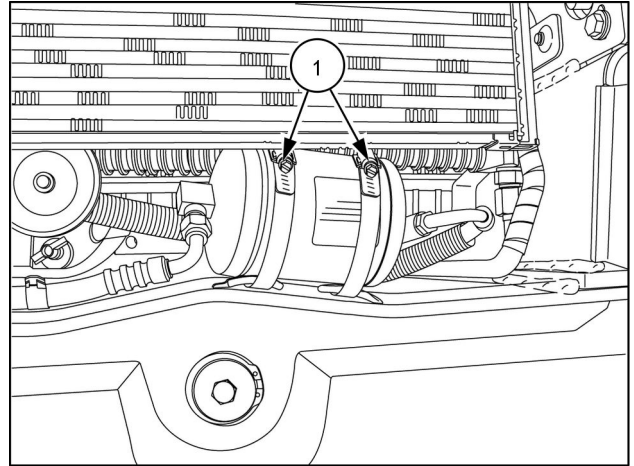

RAPH11TLB0036BA 15

25. Label and disconnect the hydraulic oil hoses **(1)** leading to the hydraulic oil cooler.

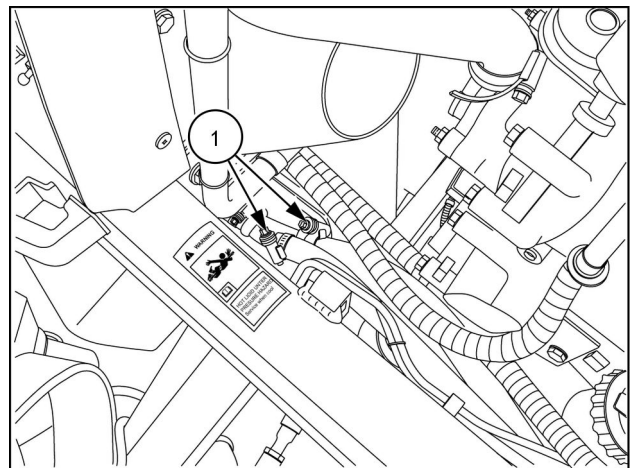

RAPH11TLB0034BA 16

26. Disconnect the lower radiator hose **(1)** from the radiator.
27. Label and disconnect the transmission oil cooler hoses **(2)** leading to the transmission oil cooler.

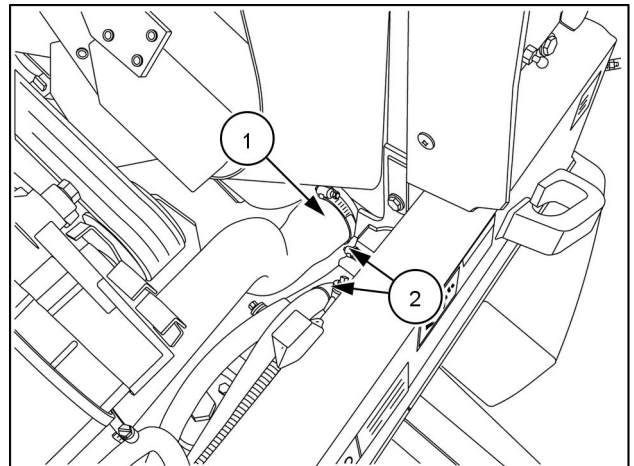

RAPH11TLB0033BA 17

28. Disconnect the upper radiator hose (1) from the radiator.

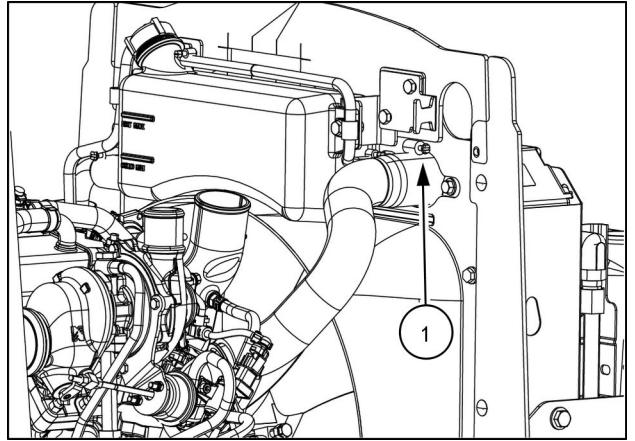

RAIL16TLB1128BA 18

29. Disconnect the A/C high pressure line (1).
 30. Disconnect the A/C low pressure line (5).
 31. Locate and disconnect the A/C compressor electrical connection (4).
 32. Disconnect the engine electrical connectors (2) and (3).

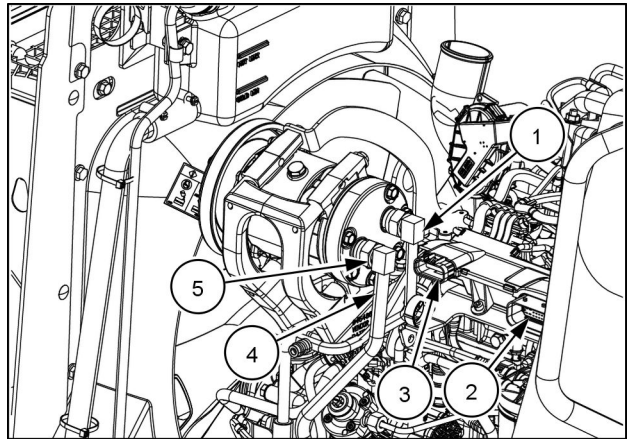

RAIL16TLB1127BA 19

33. Use a suitable lifting device and support the cooling package.

NOTICE: You may choose to remove the fan but it is not necessary as long as you are careful; move slowly and control the movement of the cooling package outward away from the fan.

34. Remove the hood strut post (2) and retainer (1).
 35. Slowly remove the cooling package outward away from the fan.

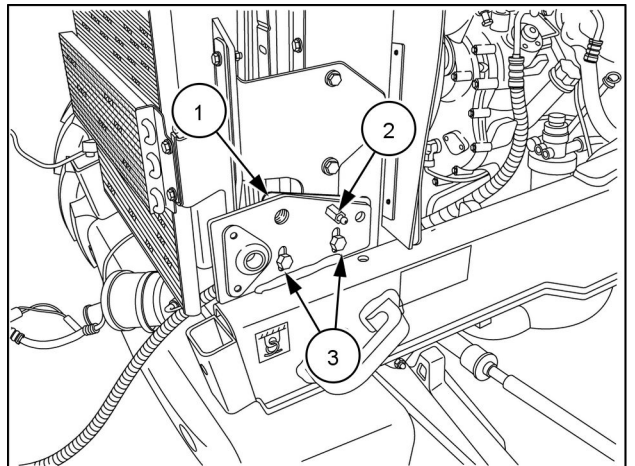

RAPH11TLB0028BA 20

36. Disconnect fuel lines (1) and (2).

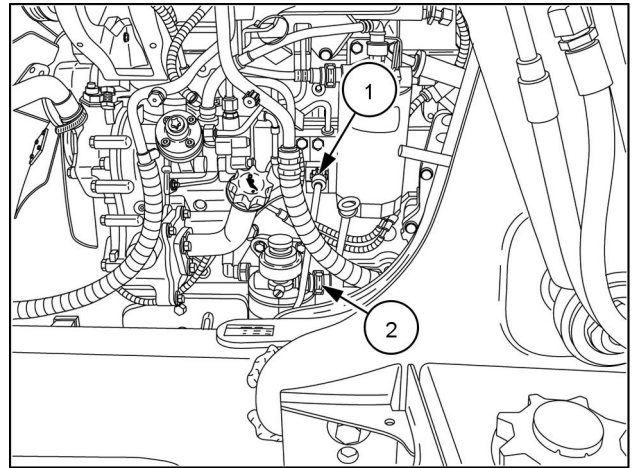

RAPH11TLB0041BA 21

37. Disconnect the water sensor electrical connector.

NOTE: Water sensor is located at the bottom of the primary fuel filter.

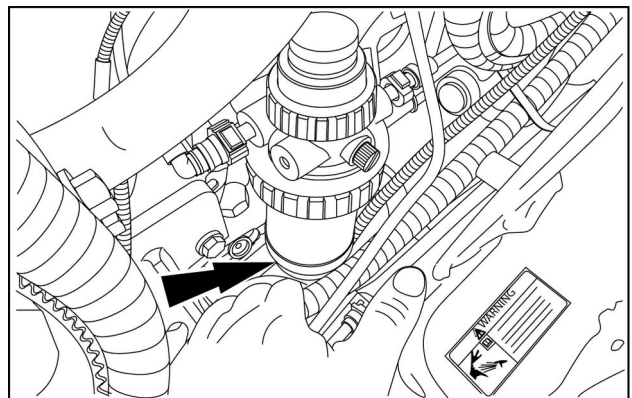

RAIL11TLB0009AA 22

38. Disconnect the glow plug control unit electrical connector (1).

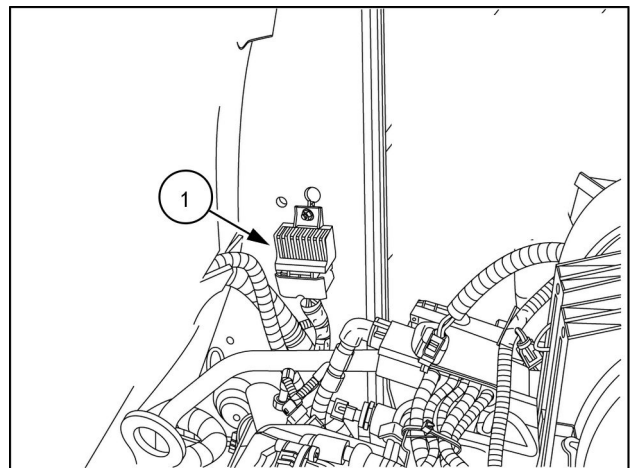

RAPH11TLB0021BA 23

39. If applicable, disconnect the heater return hose (1).

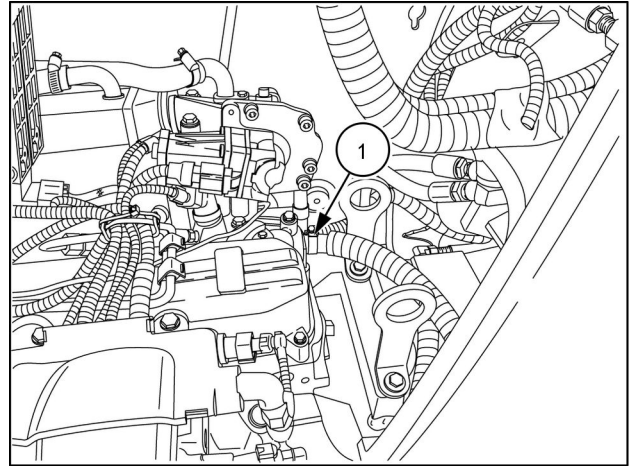

RAPH11TLB0039BA 24

40. If applicable, disconnect the heater supply hose (1).

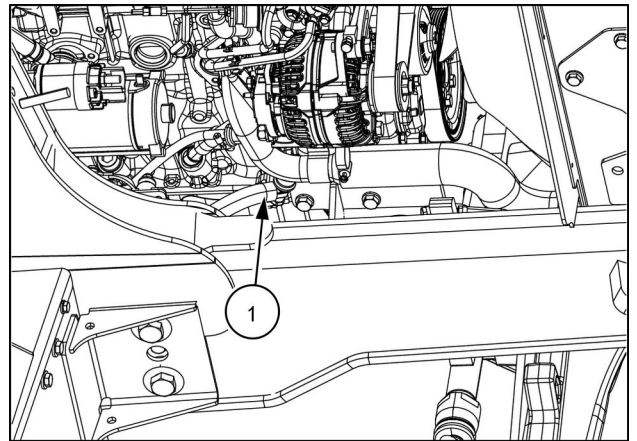

RAIL16TLB1131BA 25

41. Label and disconnect the alternator electrical connector (2) and the alternator battery wire (1).

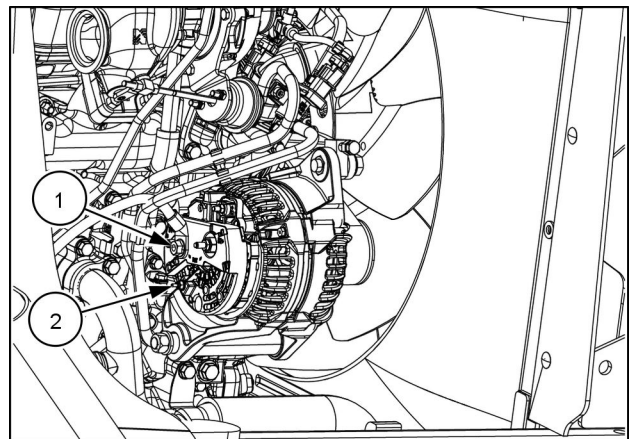

RAIL16TLB1130BA 26



Suggest:

If the above button click is invalid.

Please download this document

first, and then click the above link

to download the complete manual.

Thank you so much for reading

42. If equipped, remove the battery disconnect switch bracket from the frame and set aside.

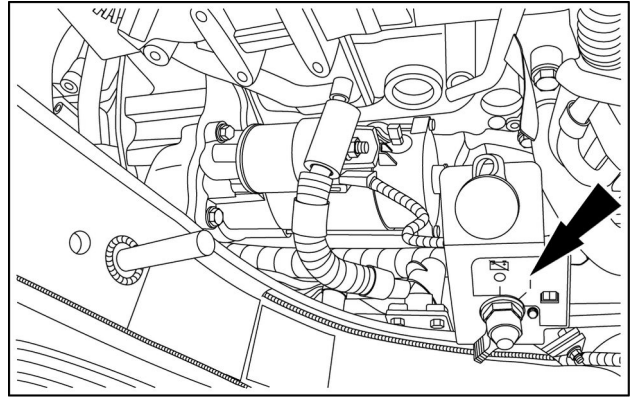

RAIL14TLB0403AA 27

43. Remove the nut (3), disconnect the wire harness (4) and positive battery cable (2) from the terminal on the starter (1).

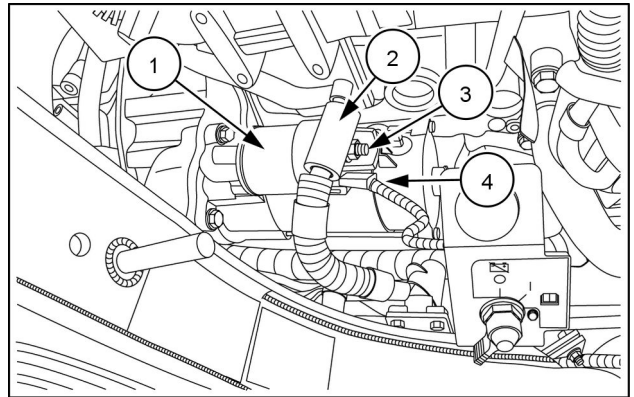

RAIL14TLB0403AA 28

44. Disconnect the ground strap.

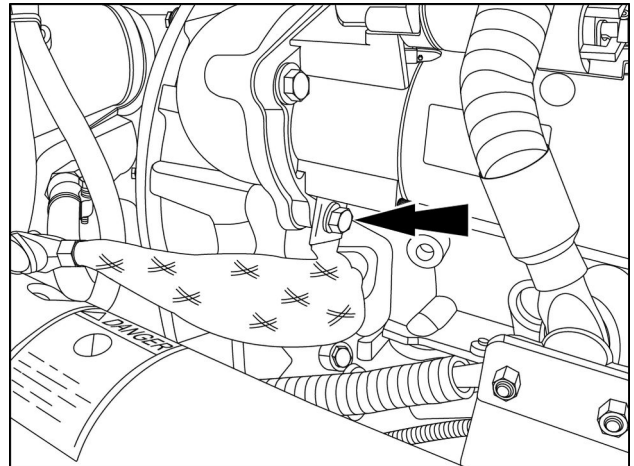

RAIL14FRK0129BA 29

<https://www.ebooklibonline.com>

Hello dear friend!

Thank you very much for reading.

Enter the link into your browser.

The full manual is available for immediate download.

<https://www.ebooklibonline.com>