

JOHN DEERE
WORLDWIDE COMMERCIAL & CONSUMER
EQUIPMENT DIVISION

John Deere Select Series™ Tractors
Ultimate™ Series
X700, X720, X724 and X728
TM2349 SEPTEMBER 2005
TECHNICAL MANUAL



JOHN DEERE

North American Version
Litho In U.s.a.

INTRODUCTION

Manual Description

This technical manual is written for an experienced technician and contains sections that are specifically for this product. It is a part of a total product support program.

The manual is organized so that all the information on a particular system is kept together. The order of grouping is as follows:

- Table of Contents
- Specifications and Information
- Identification Numbers
- Tools and Materials
- Component Location
- Schematics and Harnesses
- Theory of Operation
- Operation and Diagnostics
- Diagnostics
- Tests and Adjustments
- Repair
- Other

Note: Depending on the particular section or system being covered, not all of the above groups may be used.

The bleed tabs for the pages of each section will align with the sections listed on this page. Page numbering is consecutive from the beginning of the Safety section through the last section.

We appreciate your input on this manual. If you find any errors or want to comment on the layout of the manual please contact us.

Safety

Specifications and Information

Engine (Liquid-Cooled)

Electrical

Power Train

Hydraulics

Steering

Brakes

Attachments

Miscellaneous

All information, illustrations and specifications in this manual are based on the latest information at the time of publication. The right is reserved to make changes at any time without notice.

COPYRIGHT© 2005
Deere & Co.
John Deere Worldwide Commercial and
Consumer Equipment Division
All rights reserved
Previous Editions
COPYRIGHT©

<https://www.ebooklibonline.com>

Hello dear friend!

Thank you very much for reading.

Enter the link into your browser.

The full manual is available for immediate download.

<https://www.ebooklibonline.com>

SAFETY

Safety

Recognize Safety Information



MIF

This is the safety-alert symbol. When you see this symbol on your machine or in this manual, be alert to the potential for personal injury.

Follow recommended precautions and safe servicing practices.

Understand Signal Words

A signal word - DANGER, WARNING, or CAUTION - is used with the safety-alert symbol. DANGER identifies the most serious hazards.

DANGER or WARNING safety signs are located near specific hazards. General precautions are listed on CAUTION safety signs. CAUTION also calls attention to safety messages in this manual.

Replace Safety Signs

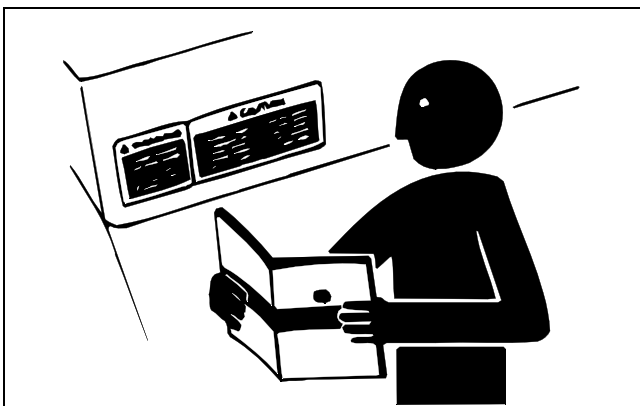

MIF

Replace missing or damaged safety signs. See the machine operator's manual for correct safety sign placement.

Handle Fluids Safely - Avoid Fires

Be Prepared For Emergencies

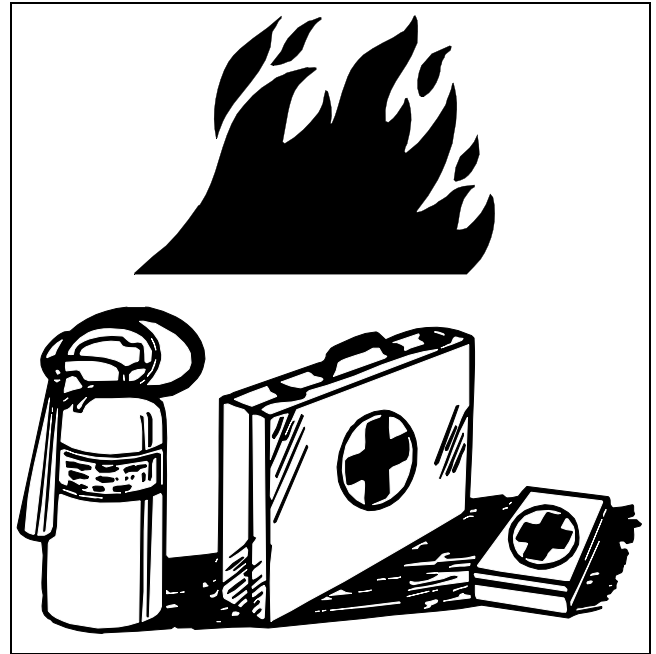

MIF

- When you work around fuel, do not smoke or work near heaters or other fire hazards.
- Store flammable fluids away from fire hazards. Do not incinerate or puncture pressurized containers.
- Make sure machine is clean of trash, grease, and debris.
- Do not store oily rags; they can ignite and burn spontaneously.
- Be prepared if a fire starts.
- Keep a first aid kit and fire extinguisher handy.
- Keep emergency numbers for doctors, ambulance service, hospital, and fire department near your telephone.

Use Care In Handling And Servicing Batteries

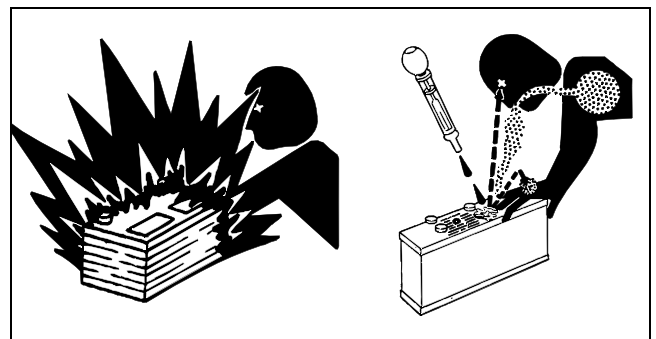

MIF

SAFETY

Prevent Battery Explosions

- Keep sparks, lighted matches, and open flame away from the top of battery. Battery gas can explode.
- Never check battery charge by placing a metal object across the posts. Use a volt-meter or hydrometer.
- Do not charge a frozen battery; it may explode. Warm battery to 16°C (60°F).

Prevent Acid Burns

- Sulfuric acid in battery electrolyte is poisonous. It is strong enough to burn skin, eat holes in clothing, and cause blindness if splashed into eyes.

Avoid acid burns by:

1. Filling batteries in a well-ventilated area.
2. Wearing eye protection and rubber gloves.
3. Avoiding breathing fumes when electrolyte is added.
4. Avoiding spilling or dripping electrolyte.
5. Use proper jump start procedure.

If you spill acid on yourself:

1. Flush your skin with water.
2. Apply baking soda or lime to help neutralize the acid.
3. Flush your eyes with water for 10 - 15 minutes.
4. Get medical attention immediately.

If acid is swallowed:

1. Drink large amounts of water or milk.
2. Then drink milk of magnesia, beaten eggs, or vegetable oil.
3. Get medical attention immediately.

Wear Protective Clothing

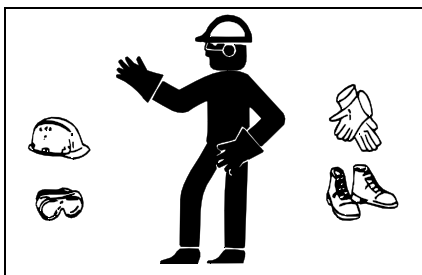

MIF

Wear close fitting clothing and safety equipment appropriate to the job.

Prolonged exposure to loud noise can cause impairment or loss of hearing. Wear a suitable hearing protective device

such as earmuffs or earplugs to protect against objectionable or uncomfortable loud noises.

Operating equipment safely requires the full attention of the operator. Do not wear radio or music headphones while operating machine.

Use Care Around High-pressure Fluid Lines

Avoid High-Pressure Fluids



MIF

Escaping fluid under pressure can penetrate the skin causing serious injury.

Avoid injury from escaping fluid under pressure by stopping the engine and relieving pressure in the system before disconnecting or connecting hydraulic or other lines. Tighten all connections before applying pressure.

Search for leaks with a piece of cardboard. Protect hands and body from high pressure fluids.

If an accident occurs, see a doctor immediately. Any fluid injected into the skin must be surgically removed within a few hours or gangrene may result. Doctors unfamiliar with this type of injury should reference a knowledgeable medical source. Such information is available from Deere & Company Medical Department in Moline, Illinois, U.S.A.

Avoid Heating Near Pressurized Fluid Lines



MIF

Flammable spray can be generated by heating near pressurized fluid lines, resulting in severe burns to yourself and bystanders. Do not heat by welding, soldering, or using a torch near pressurized fluid lines or other flammable materials. Pressurized lines can be accidentally cut when heat goes beyond the immediate flame area.

SAFETY

Service Machines Safely

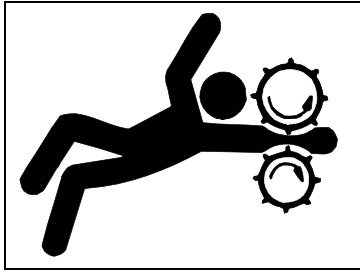

MIF

Tie long hair behind your head. Do not wear a necktie, scarf, loose clothing, or necklace when you work near machine tools or moving parts. If these items were to get caught, severe injury could result.

Remove rings and other jewelry to prevent electrical shorts and entanglement in moving parts.

Use Proper Tools

Use tools appropriate to the work. Makeshift tools and procedures can create safety hazards. Use power tools only to loosen threaded parts and fasteners. For loosening and tightening hardware, use the correct size tools. **DO NOT** use U.S. measurement tools on metric fasteners. Avoid bodily injury caused by slipping wrenches. Use only service parts meeting John Deere specifications.

Park Machine Safely

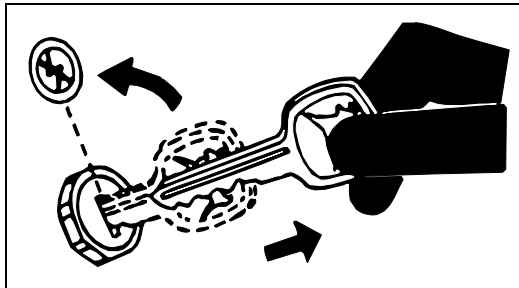

MIF

Before working on the machine:

1. Lower all equipment to the ground.
2. Stop the engine and remove the key.
3. Disconnect the battery ground strap.
4. Hang a "DO NOT OPERATE" tag in operator station.

Support Machine Properly and Use Proper Lifting Equipment

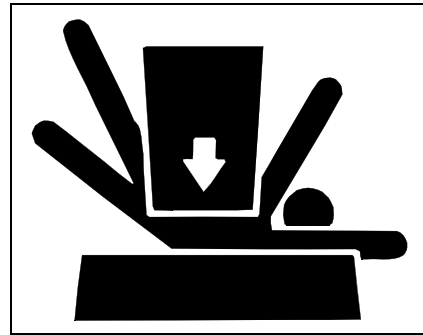

MIF

If you must work on a lifted machine or attachment, securely support the machine or attachment.

Do not support the machine on cinder blocks, hollow tiles, or props that may crumble under continuous load. Do not work under a machine that is supported solely by a jack. Follow recommended procedures in this manual.

Lifting heavy components incorrectly can cause severe injury or machine damage. Follow recommended procedure for removal and installation of components in the manual.

Work In Clean Area

Before starting a job:

1. Clean work area and machine.
2. Make sure you have all necessary tools to do your job.
3. Have the right parts on hand.
4. Read all instructions thoroughly; do not attempt shortcuts.

Using High Pressure Washers

Directing pressurized water at electronic/electrical components or connectors, bearings, hydraulic seals, fuel injection pumps or other sensitive parts and components may cause product malfunctions. Reduce pressure and spray at a 45 to 90 degree angle.

Illuminate Work Area Safely

Illuminate your work area adequately but safely. Use a portable safety light for working inside or under the machine. Make sure the bulb is enclosed by a wire cage. The hot filament of an accidentally broken bulb can ignite spilled fuel or oil.

SAFETY

Work In Ventilated Area

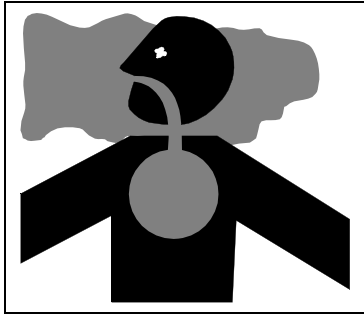

MIF

Engine exhaust fumes can cause sickness or death. If it is necessary to run an engine in an enclosed area, remove the exhaust fumes from the area with an exhaust pipe extension.

If you do not have an exhaust pipe extension, open the doors and get outside air into the area.

Warning: California Proposition 65 Warning

Gasoline engine exhaust from this product contains chemicals known to the State of California to cause cancer, birth defects, or other reproductive harm.

Diesel engine exhaust and some of its constituents are known to the State of California to cause cancer, birth defects, and other reproductive harm.

Remove Paint Before Welding or Heating

Avoid potentially toxic fumes and dust. Hazardous fumes can be generated when paint is heated by welding, soldering, or using a torch. Do all work outside or in a well ventilated area. Dispose of paint and solvent properly. Remove paint before welding or heating: If you sand or grind paint, avoid breathing the dust. Wear an approved respirator. If you use solvent or paint stripper, remove stripper with soap and water before welding. Remove solvent or paint stripper containers and other flammable material from area. Allow fumes to disperse at least 15 minutes before welding or heating.

Avoid Harmful Asbestos Dust

Avoid breathing dust that may be generated when handling components containing asbestos fibers. Inhaled asbestos fibers may cause lung cancer.

Components in products that may contain asbestos fibers are brake pads, brake band and lining assemblies, clutch plates, and some gaskets. The asbestos used in these components is usually found in a resin or sealed in some way. Normal handling is not hazardous as long as airborne dust containing asbestos is not generated.

Avoid creating dust. Never use compressed air for cleaning. Avoid brushing or grinding material containing asbestos. When servicing, wear an approved respirator. A special vacuum cleaner is recommended to clean asbestos. If not available, apply a mist of oil or water on the material containing asbestos. Keep bystanders away from the area.

Service Tires Safely

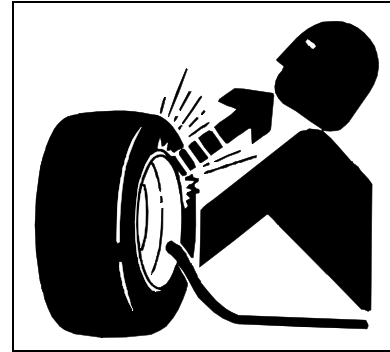

MIF

Explosive separation of a tire and rim parts can cause serious injury or death.

Do not attempt to mount a tire unless you have the proper equipment and experience to perform the job.

Always maintain the correct tire pressure. Do not inflate the tires above the recommended pressure. Never weld or heat a wheel and tire assembly. The heat can cause an increase in air pressure resulting in a tire explosion. Welding can structurally weaken or deform the wheel.

When inflating tires, use a clip-on chuck and extension hose long enough to allow you to stand to one side and NOT in front of or over the tire assembly. Use a safety cage if available.

Check wheels for low pressure, cuts, bubbles, damaged rims or missing lug bolts and nuts.

SAFETY

Avoid Injury From Rotating Blades, Augers And PTO Shafts

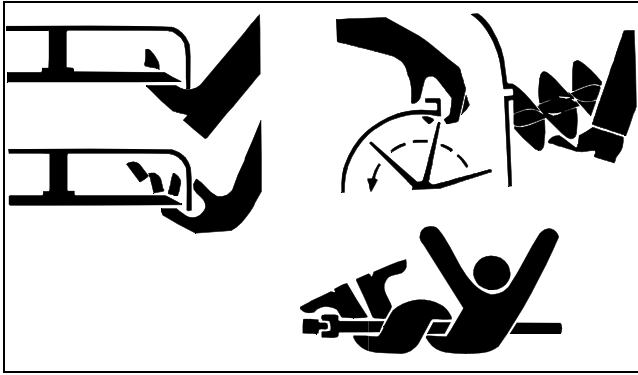

MIF

Keep hands and feet away while machine is running. Shut off power to service, lubricate or remove mower blades, augers or PTO shafts.

Service Cooling System Safely

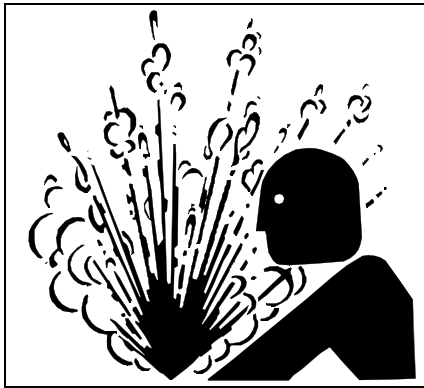

MIF

Explosive release of fluids from pressurized cooling system can cause serious burns.

Shut off machine. Only remove filler cap when cool enough to touch with bare hands. Slowly loosen cap to first stop to relieve pressure before removing completely.

Handle Chemical Products Safely

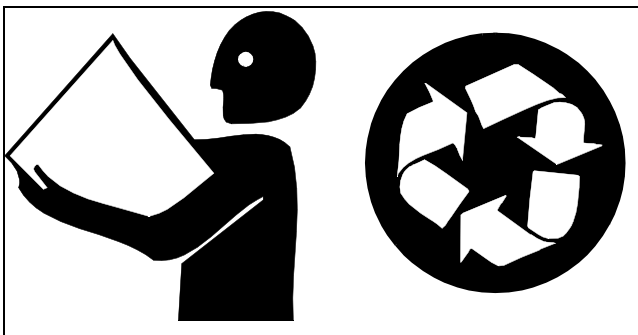

MIF

Direct exposure to hazardous chemicals can cause serious injury. Potentially hazardous chemicals used with John Deere equipment include such items as lubricants, coolants, paints, and adhesives.

A Material Safety Data Sheet (MSDS) provides specific details on chemical products: physical and health hazards, safety procedures, and emergency response techniques. Check the MSDS before you start any job using a hazardous chemical. That way you will know exactly what the risks are and how to do the job safely. Then follow procedures and recommended equipment.

Dispose of Waste Properly

Improperly disposing of waste can threaten the environment and ecology. Potentially harmful waste used with John Deere equipment include such items as oil, fuel, coolant, brake fluid, filters, and batteries. Use leakproof containers when draining fluids. Do not use food or beverage containers that may mislead someone into drinking from them. Do not pour waste onto the ground, down a drain, or into any water source. Inquire on the proper way to recycle or dispose of waste from your local environmental or recycling center, or from your John Deere dealer.

Live With Safety



MIF

Before returning machine to customer, make sure machine is functioning properly, especially the safety systems. Install all guards and shields.

SAFETY



SPECIFICATIONS & INFORMATION TABLE OF CONTENTS

Table of Contents

Fastener Torques	9
Metric Fastener Torque Values	9
Inch Fastener Torque Values	10
O-Ring Seal Service Recommendations	11
Face Seal Fittings With Inch Stud Ends	
Torque	11
Face Seal Fittings With Metric Stud Ends	
Torque	12
O-Ring Face Seal Fittings	13
O-Ring Boss Fittings	13
Straight Fitting or Special Nut Torques	14
Metric Fastener Torque Value - Grade 7	
(Special)	14
General Information	14
Gasoline	14
Gasoline Storage.....	15
4 - Cycle Gasoline Engine Oil	15
Break-In Engine Oil - 4-Cycle Gasoline.....	15
Hydrostatic Transmission and Hydraulic Oil.....	16
Gear Case Oil.....	16
Gear Transmission Grease	17
Alternative Lubricants.....	17
Synthetic Lubricants	17
Anti-Corrosion Grease.....	17
Mower Spindle Grease.....	17
Lubricant Storage	17
Mixing of Lubricants	18
Oil Filters	18
Coolant Specifications	18
Gasoline Engine Coolant.....	18
Gasoline Engine Coolant Drain Interval	19
Serial Number Locations	19
Product Serial Number	19
Gasoline Engine Serial Number Location	19

























SPECIFICATIONS & INFORMATION TABLE OF CONTENTS



SPECIFICATIONS & INFORMATION FASTENER TORQUES

Fastener Torques

Metric Fastener Torque Values

Property Class and Head Markings	4.8   	8.8 9.8    	10.9  	12.9    
Property Class and Nut Markings	5   	10   	10   	12   

MIF

SIZE	Class 4.8				Class 8.8 or 9.8				Class 10.9				Class 12.9			
	Lubricated a		Dry a		Lubricated a		Dry a		Lubricated a		Dry a		Lubricated a		Dry a	
	N•m	lb-ft	N•m	lb-ft	N•m	lb-ft	N•m	lb-ft	N•m	lb-ft	N•m	lb-ft	N•m	lb-ft	N•m	lb-ft
M6	4.8	3.5	6	4.5	9	6.5	11	8.5	13	9.5	17	12	15	11.5	19	14.5
M8	12	8.5	15	11	22	16	28	20	32	24	40	30	37	28	47	35
M10	23	17	29	21	43	32	55	40	63	47	80	60	75	55	95	70
M12	40	29	50	37	75	55	95	70	110	80	140	105	130	95	165	120
M14	63	47	80	60	120	88	150	110	175	130	225	165	205	150	260	109
M16	100	73	125	92	190	140	240	175	275	200	350	225	320	240	400	300
M18	135	100	175	125	260	195	330	250	375	275	475	350	440	325	560	410
M20	190	140	240	180	375	275	475	350	530	400	675	500	625	460	800	580
M22	260	190	330	250	510	375	650	475	725	540	925	675	850	625	1075	800
M24	330	250	425	310	650	475	825	600	925	675	1150	850	1075	800	1350	1000
M27	490	360	625	450	950	700	1200	875	1350	1000	1700	1250	1600	1150	2000	1500
M30	675	490	850	625	1300	950	1650	1200	1850	1350	2300	1700	2150	1600	2700	2000
M33	900	675	1150	850	1750	1300	2200	1650	2500	1850	3150	2350	2900	2150	3700	2750
M36	1150	850	1450	1075	2250	1650	2850	2100	3200	2350	4050	3000	3750	2750	4750	3500

DO NOT use these hand torque values if a different torque value or tightening procedure is given for a specific application. Torque values listed are for general use only and include a $\pm 10\%$ variance factor. Check tightness of fasteners periodically. DO NOT use air powered wrenches.

Shear bolts are designed to fail under predetermined loads. Always replace shear bolts with identical grade.

Fasteners should be replaced with the same grade. Make sure fastener threads are clean and that you properly start thread engagement. This will prevent them from failing when tightening.

When bolt and nut combination fasteners are used, torque values should be applied to the NUT instead of the bolt head.







Tighten toothed or serrated-type lock nuts to the full torque value.

a "Lubricated" means coated with a lubricant such as engine oil, or fasteners with phosphate and oil coatings. "Dry" means plain or zinc plated (yellow dichromate - Specification JDS117) without any lubrication.

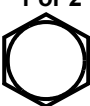
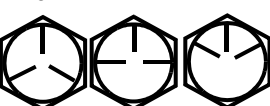
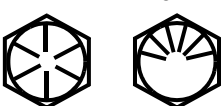
Reference: JDS - G200.

SPECIFICATIONS & INFORMATION FASTENER TORQUES

Inch Fastener Torque Values

SAE Grade and Head Markings	1 or 2 ^b No Marks 	5 5.1 5.2 	8 8.2 
SAE Grade and Nut Markings	2 No Marks 	5  	8  

MIF

SIZE	Grade 1		Grade 2b				Grade 5, 5.1 or 5.2				Grade 8 or 8.2					
	Lubricated a		Dry a		Lubricated a		Dry a		Lubricated a		Dry a		Lubricated a		Dry a	
	N•m	lb-ft	N•m	lb-ft	N•m	lb-ft	N•m	lb-ft	N•m	lb-ft	N•m	lb-ft	N•m	lb-ft	N•m	lb-ft
1/4	3.7	2.8	4.7	3.5	6	4.5	7.5	5.5	9.5	7	12	9	13.5	10	17	12.5
5/16	7.7	5.5	10	7	12	9	15	11	20	15	25	18	28	21	35	26
3/8	14	10	17	13	22	16	27	20	35	26	44	33	50	36	63	46
7/16	22	16	28	20	35	26	44	32	55	41	70	52	80	58	100	75
1/2	33	25	42	31	53	39	67	50	85	63	110	80	120	90	150	115
9/16	48	36	60	45	75	56	95	70	125	90	155	115	175	130	225	160
5/8	67	50	85	62	105	78	135	100	170	125	215	160	215	160	300	225
3/4	120	87	150	110	190	140	240	175	300	225	375	280	425	310	550	400
7/8	190	140	240	175	190	140	240	175	490	360	625	450	700	500	875	650
1	290	210	360	270	290	210	360	270	725	540	925	675	1050	750	1300	975
1-1/8	470	300	510	375	470	300	510	375	900	675	1150	850	1450	1075	1850	1350
1-1/4	570	425	725	530	570	425	725	530	1300	950	1650	1200	2050	1500	2600	1950
1-3/8	750	550	950	700	750	550	950	700	1700	1250	2150	1550	2700	2000	3400	2550
1-1/2	1000	725	1250	925	990	725	1250	930	2250	1650	2850	2100	3600	2650	4550	3350

DO NOT use these hand torque values if a different torque value or tightening procedure is given for a specific application. Torque values listed are for general use only and include a ±10% variance factor. Check tightness of fasteners periodically. DO NOT use air powered wrenches.

Shear bolts are designed to fail under predetermined loads. Always replace shear bolts with identical grade.

Fasteners should be replaced with the same grade. Make sure fastener threads are clean and that you properly start thread engagement. This will prevent them from failing when tightening.

When bolt and nut combination fasteners are used, torque values should be applied to the NUT instead of the bolt

head.

Tighten toothed or serrated-type lock nuts to the full torque value.

a "Lubricated" means coated with a lubricant such as engine oil, or fasteners with phosphate and oil coatings. "Dry" means plain or zinc plated (yellow dichromate - Specification JDS117) without any lubrication.

b "Grade 2" applies for hex cap screws (Not Hex Bolts) up to 152 mm (6 in.) long. "Grade 1" applies for hex cap screws over 152 mm (6 in.) long, and for all other types of bolts and screws of any length.

Reference: JDS - G200

SPECIFICATIONS & INFORMATION O-RING SEAL SERVICE

O-Ring Seal Service Recommendations

Face Seal Fittings With Inch Stud Ends Torque

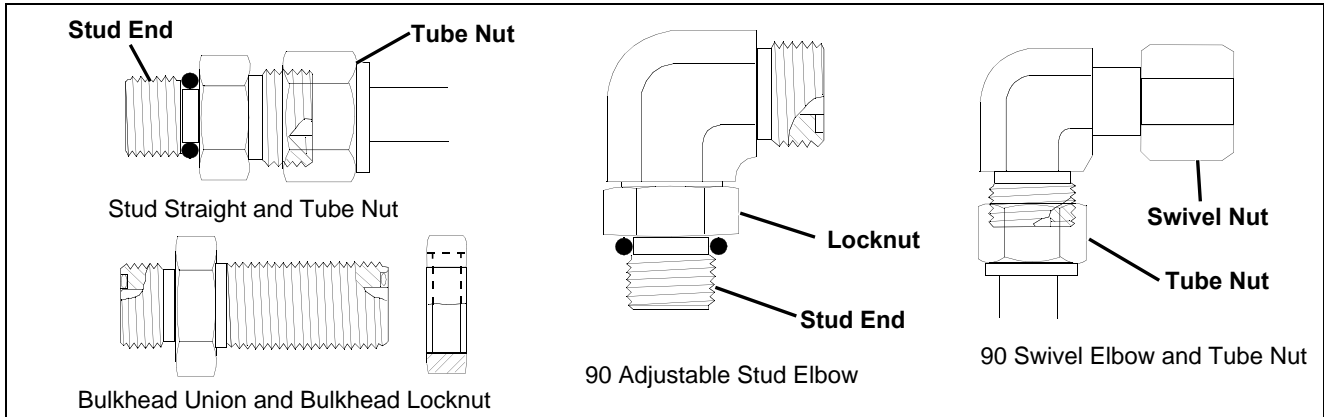

MIF

Nominal Tube OD/Hose ID				Face Seal Tube/Hose End					O-Ring Stud Ends		
Metric Tube OD	Inch Tube OD			Thread Size	Tube Nut/ Swivel Nut Torque		Bulkhead Lock Nut Torque		Thread Size	Straight Fitting or Lock Nut Torque	
	mm	Dash Size	in.		mm	in.	N•m	lb-ft		N•m	lb-ft
5	-3	0.188	4.76						3/8-24	8	6
6	-4	0.250	6.35	9/16-18	16	12	12	9	7/16-20	12	9
8	-5	0.312	7.94						1/2-20	16	12
10	-6	0.375	9.52	11/16-16	24	18	24	18	9/16-18	24	18
12	-8	0.500	12.70	13/16-16	50	37	46	34	3/4-16	46	34
16	-10	0.625	15.88	1-14	69	51	62	46	7/8-14	62	46
19	-12	0.750	19.05	1-3/16-12	102	75	102	75	1-1/16-12	102	75
22	-14	0.875	22.22	1-3/16-12	102	75	102	75	1-3/16-12	122	90
25	-16	1.000	25.40	1-7/16-12	142	105	142	105	1-5/16-12	142	105
32	-20	1.25	31.75	1-11/16-12	190	140	190	140	1-5/8-12	190	140
38	-24	1.50	38.10	2-12	217	160	217	160	1-7/8-12	217	160

Note: Torque tolerance is +15%, -20%

SPECIFICATIONS & INFORMATION O-RING SEAL SERVICE

Face Seal Fittings With Metric Stud Ends Torque

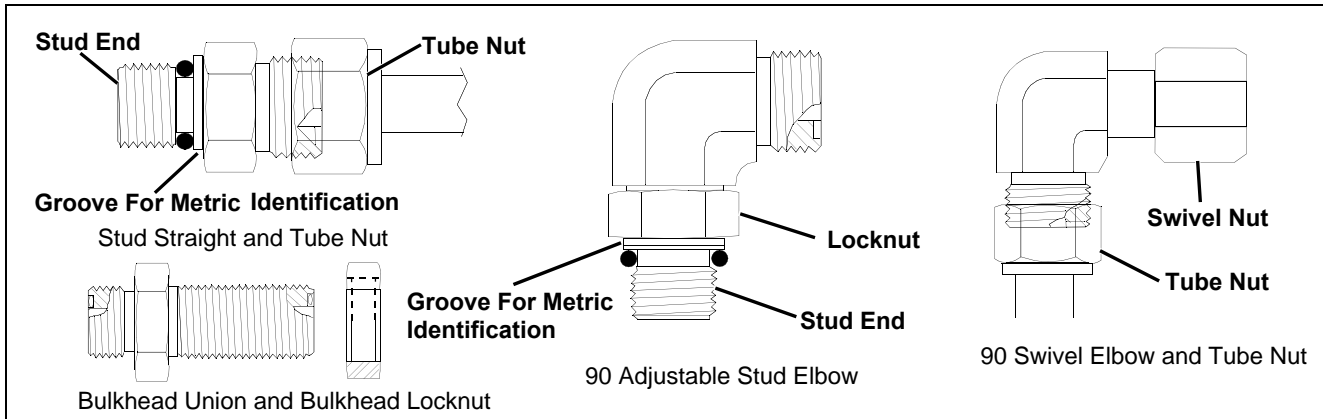

MIF

Nominal Tube OD/Hose ID				Face Seal Tube/Hose End						O-Ring Stud Ends, Straight Fitting or Lock Nut					
Metric Tube OD	Inch Tube OD			Thread Size	Hex Size	Tube Nut/ Swivel Nut Torque		Bulkhead Lock Nut Torque		Thread Size	Hex Size	Steel or Gray Iron Torque		Aluminum Torque	
	Dash Size	in.	mm			in.	mm	N•m	lb-ft			N•m	lb-ft	mm	mm
6	-4	0.250	6.35	9/16-18	17	16	12	12	9	M12X1.5	17	21	15.5	9	6.6
8	-5	0.312	7.94												
										M14X1.5	19	33	24	15	11
10	-6	0.375	9.52	11/16-16	22	24	18	24	18	M16X1.5	22	41	30	18	13
12	-8	0.500	12.70	13/16-16	24	50	37	46	34	M18X1.5	24	50	37	21	15
16	-10	0.625	15.88	1-14	30	69	51	62	46	M22X1.5	27	69	51	28	21
	-12	0.750	19.05	1-3/16-12	36	102	75	102	75	M27X2	32	102	75	46	34
22	-14	0.875	22.22	1-3/16-12	36	102	75	102	75	M30X2	36				
25	-16	1.000	25.40	1-7/16-12	41	142	105	142	105	M33X2	41	158	116	71	52
28										M38X2	46	176	130	79	58
32	-20	1.25	31.75	1-11/16-12	50	190	140	190	140	M42X2	50	190	140	85	63
38	-24	1.50	38.10	2-12	60	217	160	217	160	M48X2	55	217	160	98	72

Note: Torque tolerance is +15%, -20%

SPECIFICATIONS & INFORMATION O-RING SEAL SERVICE

O-Ring Face Seal Fittings

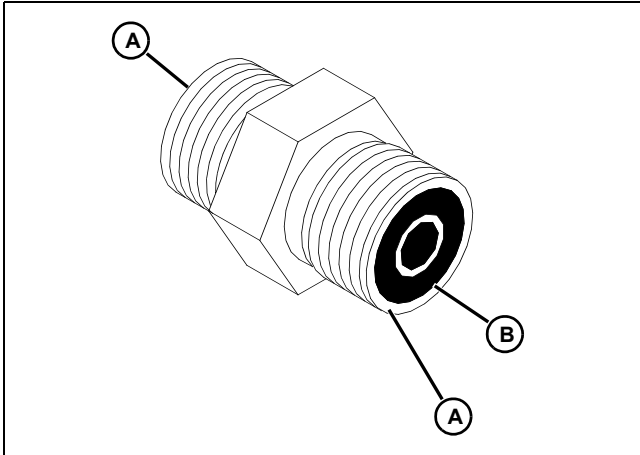

1. Inspect the fitting sealing surfaces (A). They must be free of dirt or defects.
2. Inspect the O-ring (B). It must be free of damage or defects.
3. Lubricate O-rings and install into groove using petroleum jelly to hold in place during assembly.
4. Index angle fittings and tighten by hand pressing joint together to insure O-ring remains in place.

Important: Avoid Damage! DO NOT allow hoses to twist when tightening fittings. Use two wrenches to tighten hose connections; one to hold the hose, and the other to tighten the swivel fitting.

5. Tighten fitting or nut to torque value shown on the chart per dash size stamped on the fitting.

O-Ring Boss Fittings

1. Inspect boss O-ring boss seat. It must be free of dirt and defects. If repeated leaks occur, inspect for defects with a magnifying glass. Some raised defects can be removed with a slip stone.

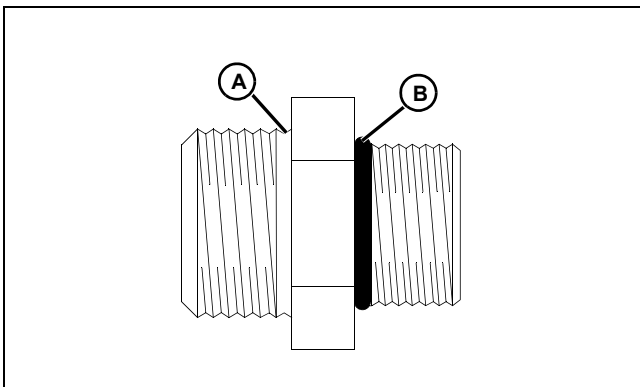

2. Put hydraulic oil or petroleum jelly on the O-ring (B). Place electrical tape over the threads to protect O-ring from nicks. Slide O-ring over the tape and into the groove (A) of fitting. Remove tape.

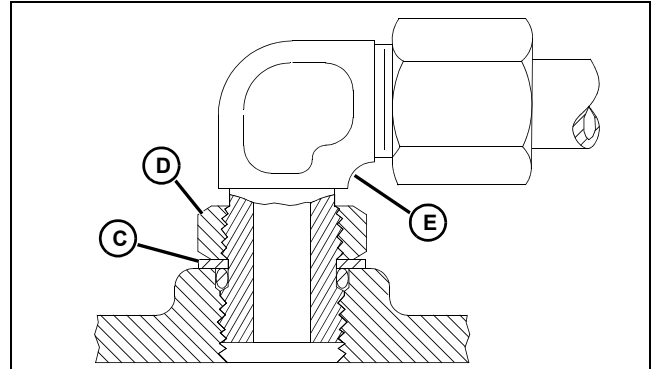

3. For angle fittings, loosen special nut (D) and push special washer (C) against threads so O-ring can be installed into the groove of fitting.
4. Turn fitting into the boss by hand until special washer or washer face (straight fitting) contacts boss face and O-ring is squeezed into its seat.
5. To position angle fittings (E), turn the fitting counter-clockwise a maximum of one turn.
6. Tighten straight fittings to torque value shown on chart. For angle fittings, tighten the special nut to value shown in the chart while holding body of fitting with a wrench.

SPECIFICATIONS & INFORMATION GENERAL INFORMATION

Straight Fitting or Special Nut Torques

Thread Size	Torque ^a		Number of Flats ^b
	N•m	lb-ft	
3/8-24 UNF	8	6	2
7/16-20 UNF	12	9	2
1/2-20 UNF	16	12	2
9/16-18 UNF	24	18	2
3/4-16 UNF	46	34	2
7/8-14 UNF	62	46	1-1/2
1-1/16-12 UN	102	75	1
1-3/16-12 UN	122	90	1
1-5/16-12 UN	142	105	3/4
1-5/8-12 UN	190	140	3/4
1-7/8-12 UN	217	160	1/2

^aTorque tolerance is ± 10 percent.

^bTo be used if a torque wrench cannot be used. After tightening fitting by hand, put a mark on nut or boss; then tighten special nut or straight fitting the number of flats shown.

Metric Fastener Torque Value - Grade 7 (Special)

Size	Steel or Gray Iron Torque	Aluminum Torque
	N•m (lb-ft)	N•m (lb-ft)
M6	11 (8)	8 (6)
M8	24 (18)	19 (14)
M10	52 (38)	41 (30)
M12	88 (65)	70 (52)
M14	138 (102)	111 (82)
M16	224 (165)	179 (132)

General Information

Gasoline

4 - Cycle Engines



Caution: Avoid Injury! Gasoline is HIGHLY FLAMMABLE, handle it with care.

DO NOT refuel machine while: indoors, always fill gas tank outdoors; machine is near an open flame or sparks; engine is running, STOP engine; engine is hot, allow it to cool sufficiently first; smoking.

Help prevent fires: fill gas tank to bottom of filler neck only; be sure fill cap is tight after fueling; clean up any gas spills IMMEDIATELY; keep machine clean and in good repair - free of excess grease, oil, debris, and faulty or damaged parts; any storage of machines with gas left in tank should be in an area that is well ventilated to prevent possible igniting of fumes by an open flame or spark, this includes any appliance with a pilot light.

To prevent fire or explosion caused by STATIC ELECTRIC DISCHARGE during fueling:

- **ONLY use a clean, approved POLYETHYLENE PLASTIC fuel container and funnel WITHOUT any metal screen or filter.**

To avoid engine damage:

- DO NOT mix oil with gasoline;
- **ONLY use clean, fresh unleaded gasoline with an octane rating (anti-knock index) of 87 or higher;**
- fill gas tank at the end of each day's operation to help prevent condensation from forming inside a partially filled tank;
- keep up with specified service intervals.

Use of alternative oxygenated, gasohol blended, unleaded gasoline is acceptable as long as:

- the ethyl or grain alcohol blends DO NOT exceed 10% by volume or
- methyl tertiary butyl ether (MTBE) blends DO NOT exceed 15% by volume

RFG (reformulated) gasoline is acceptable for all machines designed for use of regular unleaded fuel. Older machines (that were designed for leaded fuel) may see some accelerated valve and seat wear.

SPECIFICATIONS & INFORMATION GENERAL INFORMATION

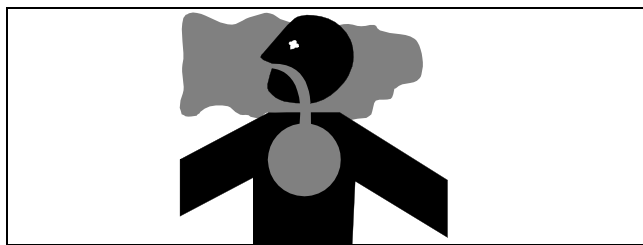

MIF

Important: Avoid Damage! California Proposition 65 Warning: Gasoline engine exhaust from this product contains chemicals known to the State of California to cause cancer, birth defects, or other reproductive harm.

Gasoline Storage

Important: Avoid Damage! Keep all dirt, scale, water or other foreign material out of gasoline.

Keep gasoline stored in a safe, protected area. Storage of gasoline in a clean, properly marked ("UNLEADED GASOLINE") POLYETHYLENE PLASTIC container WITHOUT any metal screen or filter is recommended. DO NOT use de-icers to attempt to remove water from gasoline or depend on fuel filters to remove water from gasoline. Use a water separator installed in the storage tank outlet. BE SURE to properly discard unstable or contaminated gasoline. When storing the machine or gasoline, it is recommended that you add **John Deere Gasoline Conditioner and Stabilizer (TY15977)** or an equivalent to the gasoline. BE SURE to follow directions on container and to properly discard empty container.

4 - Cycle Gasoline Engine Oil

Use the appropriate oil viscosity based on the expected air temperature range during the period between recommended oil changes. Operating outside of these recommended oil air temperature ranges may cause premature engine failure.

The following John Deere oils are **PREFERRED**:

- **PLUS - 4 - SAE 10W-40;**
- **TORQ - GARD SUPREME - SAE 5W-30.**

The following John Deere oils are **also recommended**, based on their specified temperature range:

- **TURF - GARD - SAE 10W-30;**
- **PLUS - 4 - SAE 10W-30;**
- **TORQ - GARD SUPREME - SAE 30.**

Other oils may be used if above John Deere oils are not available, provided they meet one of the following specifications:

- SAE 10W-40 - API Service Classifications SG or higher;
- SAE 5W-30 - API Service Classification SG or higher;
- SAE 10W-30 - API Service Classifications SG or higher;
- SAE 30 - API Service Classification SC or higher.

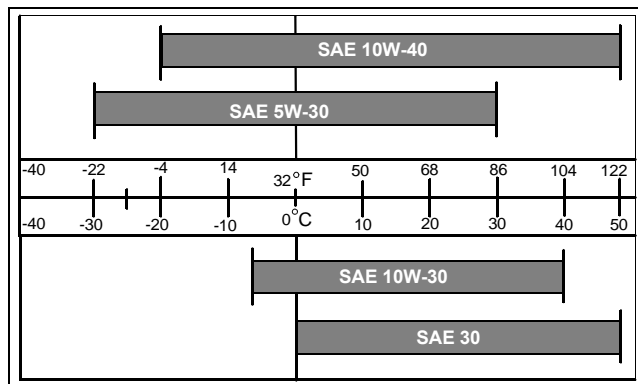

Break-In Engine Oil - 4-Cycle Gasoline

Important: Avoid Damage! ONLY use a quality break-in oil in rebuilt or remanufactured engines for the first 5 hours (maximum) of operation. DO NOT use oils with heavier viscosity weights than SAE 5W-30 or oils meeting specifications API SG or SH, these oils will not allow rebuilt or remanufactured engines to break-in properly.

The following John Deere oil is **PREFERRED**:

- **BREAK - IN ENGINE OIL.**

John Deere **BREAK - IN ENGINE OIL** is formulated with special additives for aluminum and cast iron type engines to allow the power cylinder components (pistons, rings, and liners as well) to "wear-in" while protecting other engine components, valve train and gears, from abnormal wear. Engine rebuild instructions should be followed closely to determine if special requirements are necessary.

John Deere **BREAK - IN ENGINE OIL** is also recommended for non-John Deere engines, both aluminum and cast iron types.

The following John Deere oil is **also recommended**:

- **TORQ - GARD SUPREME® - SAE 5W-30.**

If the above recommended John Deere oils are not available, use a break-in engine oil meeting the following specification during the first **5 hours (maximum)** of operation:

- SAE 5W-30 - API Service Classification SE or higher.

SPECIFICATIONS & INFORMATION GENERAL INFORMATION

Important: Avoid Damage! After the break-in period, use the John Deere oil that is recommended for this engine.

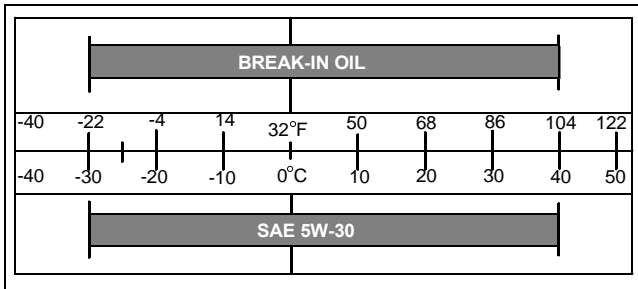

Hydrostatic Transmission and Hydraulic Oil

Use the appropriate oil viscosity based on these air temperature ranges. Operating outside of these recommended oil air temperature ranges may cause premature hydrostatic transmission or hydraulic system failures.

Important: Avoid Damage! Mixing of LOW VISCOSITY HY - GARD® and HY - GARD® oils is permitted. DO NOT mix any other oils in this transmission. DO NOT use engine oil or "Type F" (Red) Automatic Transmission Fluid in this transmission. DO NOT use BIO-HY-GARD® in this transmission.

The following John Deere transmission and hydraulic oil is **PREFERRED**:

- **LOW VISCOSITY HY-GARD® - JDM J20D.**

The following John Deere oil is also recommended if above preferred oil is not available:

- **HY-GARD® - JDM J20C.**

Other oils may be used if above recommended John Deere oils are not available, provided they meet one of the following specifications:

- John Deere Standard JDM J20D;
- John Deere Standard JDM J20C.

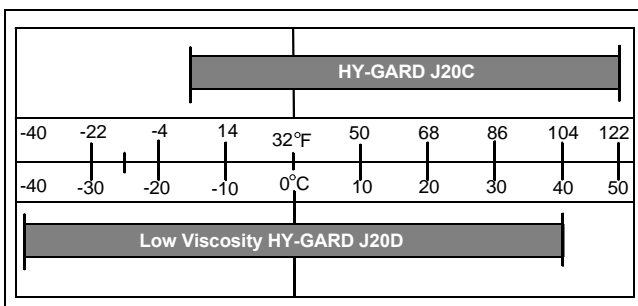

Gear Case Oil

Use the appropriate oil viscosity based on the air temperature ranges. Operating outside of these recommended oil air temperature ranges may cause premature gear case failure.

Important: Avoid Damage! ONLY use a quality oil in this gear case. DO NOT mix any other oils in this gear case. DO NOT use BIO-HY-GARD® in this gear case.

The following John Deere gear case oil is **PREFERRED**:

- **GL-5 GEAR LUBRICANT® - SAE 80W-90.**

The following John Deere gear case oil is also recommended if above preferred oil is not available:

- **GL-5 GEAR LUBRICANT® - SAE 85W-140.**

Other gear case oils may be used if above recommended John Deere gear case oils are not available, provided they meet the following specification:

- API Service Classification GL - 5.

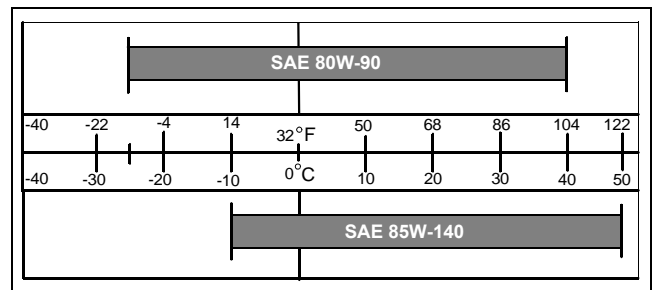

SPECIFICATIONS & INFORMATION GENERAL INFORMATION

Gear Transmission Grease

Use the following gear grease based on the air temperature range. Operating outside of the recommended grease air temperature range may cause premature gear transmission failure.

Important: Avoid Damage! ONLY use a quality gear grease in this transmission. DO NOT mix any other greases in this transmission. DO NOT use any BIO - GREASE in this transmission.

The following John Deere gear grease is **PREFERRED**:

- **NON-CLAY HIGH-TEMPERATURE EP GREASE®** - JDM J13E4, NLGI Grade 2.

Other greases may be used if above preferred John Deere grease is not available, provided they meet the following specification:

- John Deere Standard JDM J13E4, NLGI Grade 2.

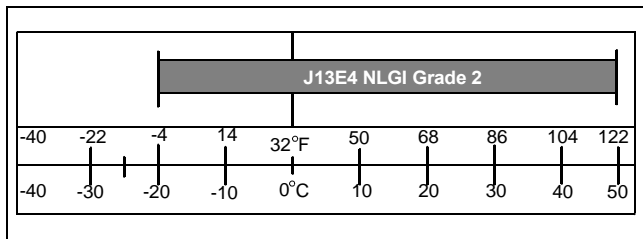

Alternative Lubricants

Use of alternative lubricants could cause reduced life of the component.

If alternative lubricants are to be used, it is recommended that the factory fill be thoroughly removed before switching to any alternative lubricant.

Synthetic Lubricants

Synthetic lubricants may be used in John Deere equipment if they meet the applicable performance requirements (industry classification and/or military specification) as shown in this manual.

The recommended air temperature limits and service or lubricant change intervals should be maintained as shown in the operator's manual, unless otherwise stated on lubricant label.

Avoid mixing different brands, grades, or types of oil. Oil manufacturers blend additives in their oils to meet certain specifications and performance requirements. Mixing different oils can interfere with the proper functioning of these additives and degrade lubricant performance.

Anti-Corrosion Grease

This anti-corrosion grease is formulated to provide the best protection against absorbing moisture, which is one of the major causes of corrosion. This grease is also superior in its resistance to separation and migration.

The following anti-corrosion grease is **preferred**:

- DuBois MPG-2™ Multi-Purpose Polymer Grease - M79292.

Other greases may be used if they meet or exceed the following specification:

- John Deere Standard JDM J13A2, NLGI Grade 1.

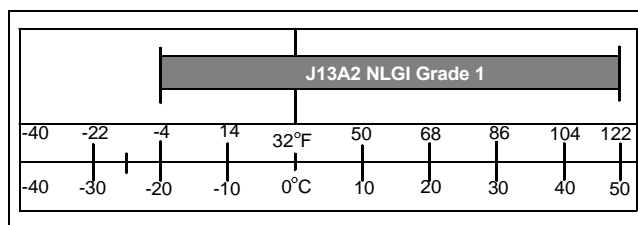

Mower Spindle Grease

This premium, multi-purpose grease is specially formulated as a high-temperature, extreme-pressure grease, especially effective in rolling contact applications.

The following water resistant grease is **preferred**:

- Multi-Purpose SD Polyurea Grease - TY6341.

The following multi-purpose grease may also be used:

- Multi-Purpose HD Lithium Complex Grease - TY24416.

Other greases may be used if they meet or exceed the following specification:

- John Deere Standard JDM J13E4, NLGI Grade 2.

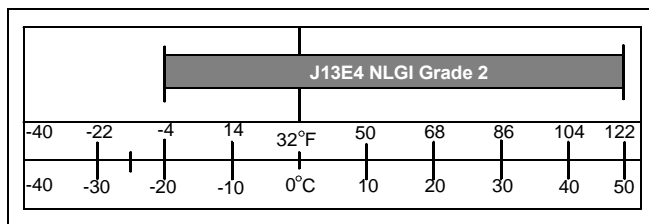

Lubricant Storage

All machines operate at top efficiency only when clean lubricants are used. Use clean storage containers to handle all lubricants. Store them in an area protected from dust, moisture, and other contamination. Store drums on their sides. Make sure all containers are properly marked as to their contents. Dispose of all old, used containers and their contents properly.

SPECIFICATIONS & INFORMATION COOLANT SPECIFICATIONS

Mixing of Lubricants

In general, avoid mixing different brands or types of lubricants. Manufacturers blend additives in their lubricants to meet certain specifications and performance requirements. Mixing different lubricants can interfere with the proper functioning of these additives and lubricant properties which will downgrade their intended specified performance.

Oil Filters

Important: Avoid Damage! Filtration of oils is critical to proper lubrication performance. Always change filters regularly.

The following John Deere oil filters are PREFERRED:

- AUTOMOTIVE AND LIGHT TRUCK ENGINE OIL FILTERS.

Most John Deere filters contain pressure relief and anti-drainback valves for better engine protection.

Other oil filters may be used if above recommended John Deere oil filters are not available, provided they meet the following specification:

- ASTB Tested In Accordance With SAE J806.

Coolant Specifications

Gasoline Engine Coolant

The engine cooling system when filled with a proper dilution mixture of anti-freeze and deionized or distilled water provides year-round protection against corrosion, cylinder or liner pitting, and winter freeze protection down to **-37°C (-34°F)**.

The following John Deere coolant is **PREFERRED**:

- **COOL-GARD® PRE-DILUTED SUMMER COOLANT (TY16036).**

This coolant satisfies specifications for “Automobile and Light Duty Engine Service” and is safe for use in John Deere Lawn and Grounds Care/Golf and Turf Division equipment, including aluminum block gasoline engines and cooling systems.

The above preferred pre-diluted anti-freeze provides:

- adequate heat transfer
- corrosion-resistant chemicals for the cooling system
- compatibility with cooling system hose and seal material
- protection during extreme cold and extreme hot weather operations
- chemically pure water for better service life
- compliance with ASTM D4656 (JDM H24C2) specifications

If above preferred pre-diluted coolant is not available, the following John Deere concentrate is recommended:

- **COOL-GARD® CONCENTRATED SUMMER COOLANT CONCENTRATE™ (TY16034).**

If either of above recommended engine coolants are available use any Automobile and Light Duty Engine Service ethylene glycol base coolant, meeting the following specification:

- ASTM D4985 (JDM H24A2).

Read container label completely before using and follow instructions as stated.

SPECIFICATIONS & INFORMATION SERIAL NUMBER LOCATIONS

Important: Avoid Damage! To prevent engine damage, DO NOT use pure anti-freeze or less than a 50% anti-freeze mixture in the cooling system. DO NOT mix or add any additives/conditioners to the cooling system in Lawn and Grounds Care/Golf and Turf Division equipment. Water used to dilute engine coolant concentrate must be of high quality - clean, clear, potable water (low in chloride and hardness - Table 1) is generally acceptable. DO NOT use salt water. Deionized or distilled water is ideal to use. Coolant that is not mixed to these specified levels and water purity can cause excessive scale, sludge deposits, and increased corrosion potential.

Property	Requirements
Total Solids, Maximum	340 ppm (20 grns/gal)
Total Hardness, Maximum	170 ppm (10 grns/gal)
Chloride (as Cl), Maximum	40 ppm (2.5 grns/gal)
Sulfate (as SO ₄), Maximum	100 ppm (5.8 grns/gal)

Mix 50 percent anti-freeze concentrate with 50 percent distilled or deionized water. This mixture and the pre-diluted mixture (TY16036) will protect the cooling system down to -37°C (-34°F) and up to 108°C (226°F).

Certain geographical areas may require lower air temperature protection. See the label on your anti-freeze container or consult your John Deere dealer to obtain the latest information and recommendations.

Gasoline Engine Coolant Drain Interval

When using John Deere Pre-Diluted (TY16036) Automobile and Light Duty Engine Service coolants, drain and flush the cooling system and refill with fresh coolant mixture every 36 months or 3,000 hours of operation, whichever comes first.

When using John Deere Concentrate (TY16034) Automobile and Light Duty Engine Service coolants, drain and flush the cooling system and refill with fresh coolant mixture every 24 months or 2,000 hours of operation, whichever comes first.

If above John Deere Automobile and Light Duty Engine Service coolants are not being used; drain, flush, and refill the cooling system according to instructions found on product container or in equipment operator's manual or technical manual.

Serial Number Locations

Product Serial Number

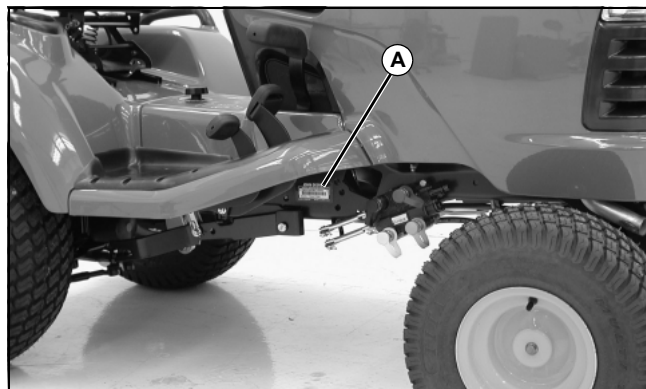

M55444

The 13-digit product identification number (A) is located on the right-hand side frame, just below engine compartment.

Gasoline Engine Serial Number Location

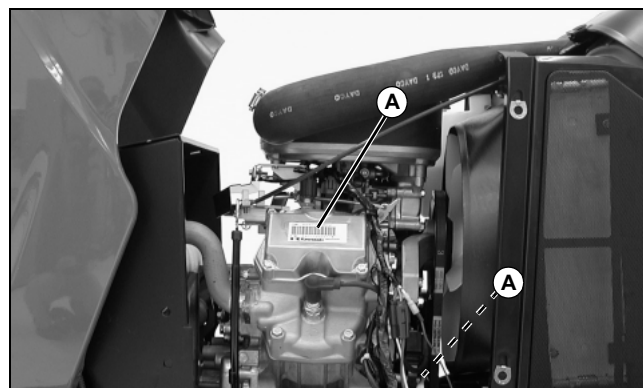

MX13637

Engine serial number (A) is located on the valve cover or on the front of the engine crankcase.



ENGINE - GAS (LIQUID-COOLED) TABLE OF CONTENTS

Table of Contents

Specifications	23
General Specifications	23
Tests and Adjustments Specifications.....	23
Repair Specifications.....	24
Torque Specifications (Alphabetical).....	25
Special or Required Tools	26
Component Location.....	27
Engine (FD671D)	27
Engine (FD750D)	28
Theory of Operation	29
Cooling System Operation	29
Fuel and Air System Operation	30
Fuel Injection Air System Components and Operation (FD750D).....	30
Fuel Pressure Regulator Operation (FD750D).....	31
Governor Operation.....	31
Lubrication System Operation	32
Throttle Body Operation (FD750D)	33
Diagnostics	34
Engine Diagnosis	34
Engine Tests	38
Tests and Adjustments	40
Throttle Lever Adjustment	40
Throttle Cable Adjustment.....	40
Choke Adjustment (FD671D)	41
Governor Adjustment	41
Low Idle Speed Adjustment.....	42
High Idle Speed Adjustment.....	42
Compression Test	43
Valve Clearance Adjustment	43
Crankcase Vacuum Test.....	44
Engine Oil Pressure Test	46
Fuel Pump Flow Test for Carburetor (FD671D).....	47
Fuel Pump Pressure Test for Carburetor (FD671D).....	47
Fuel Pump Pressure Test For Fuel Injection (FD750D).....	48
Bleed Fuel System (FD750D)	49
Fan Belt Tension Adjustment	49
Thermostat Test	50
Cooling System Test	50
Radiator Bubble Test.....	51

Radiator Cap Pressure Test	51
Water Pump/Alternator Drive Belt Adjustment.....	51
Repair	52
Thermostat Removal and Installation	52
Fan Belt Removal and Installation.....	53
Cooling Fan and Bracket Removal and Installation.....	53
Coolant Pump Removal and Installation.....	54
Radiator Removal and Installation.....	56
Muffler Removal and Installation	58
Air Cleaner Removal and Installation	58
Carburetor Removal and Installation (FD671D)	60
Throttle Body Removal and Installation (FD750D).....	62
Fuel Injector Removal and Installation (FD750D).....	63
Fuel Pressure Regulator Removal and Installa- tion (FD750D)	64
Cylinder Head Removal and Installation.....	65
Intake Manifold Removal and Installation (FD671D)	66
Intake Manifold Removal and Installation (FD750D).....	67
Starting Motor Removal and Installation.....	69
Starter Motor Disassembly and Assembly...	69
Starting Motor Inspection.....	71
Engine Removal and Installation	73
Flywheel Removal and Installation	77
Push Rod/Rocker Arm Removal and Installation.....	77
Valve Train Removal and Installation	79
Crankcase Cover Removal and Installation.	80
Crankcase Cover Inspection.....	82
Governor Assembly Removal and Installation.....	82
Piston Removal and Installation	84
Inspect Piston and Cylinder	87
Cylinder Bore Honing.....	89
Camshaft/Tappet Removal and Installation	90
Camshaft Disassembly and Inspection	91
Crankshaft Removal and Replacement	92
Crankshaft Inspection.....	92
Connecting Rod Inspection.....	94
Breather Valve Removal and Installation.....	95
Oil Pump Removal and Installation.....	95
Oil Pump Inspection.....	96

ENGINE - GAS (LIQUID-COOLED) TABLE OF CONTENTS

Oil Screen Removal and Installation	98
---	----



ENGINE - GAS (LIQUID-COOLED) SPECIFICATIONS

Specifications

General Specifications

Engine General Specifications:

Engine Use (FD671D)	X700
Engine Use (FD750D)	X720, X724, and X728
Model	Kawasaki
Model Number	FD671D
Model Number	FD750D
Displacement	745 cm ³ (45.5 cu-in.)
Cylinders	2
Stroke/Cycle	4
Valves	Overhead Valves
Bore	78 mm (3.07 in.)
Stroke	78 mm (3.07 in.)
Compression Ratio	8: 1
Compression Release	Automatic
Crankshaft Type	Horizontal (Counterbalanced)
Lubrication	Pressurized by Positive Displacement Pump
Oil Pressure	276 kPa (40 psi minimum)
Oil Filter	Cartridge Type, Full Flow, Spin-On Filter
Crankcase Capacity (With Filter)	1.8 L (1.9 qt)
Cooling System	Liquid Cooled
Cooling System Capacity	4.0 L (4.2 qt)
Air Cleaner	Dual Element replaceable paper
Muffler	Horizontal; discharge frame side
Maximum Angle of Operation (With Full Crankcase):	
Continuous (All Directions)	20°
Intermittent (All Directions)	35°
Fuel Filter	Replaceable (In-Line Type)
Fuel Pump	Electromagnetic Pump (In-Tank Type)
Fuel Shut-Off Solenoid	Replaceable (Below Carburetor Float Bowl)
Carburetor (FD671D)	Float type, fixed main jet, two barrel
Fuel Injection (FD750D)	Simultaneous port fuel injection
Spark Plug	NGK BPR4ES
Charging System	12V - 20 amps with regulator

Tests and Adjustments Specifications

Engine:

Spark Plug Gap	0.75 mm (0.030 in.)
Fan Belt Deflection	12 - 19 mm (0.48 - 0.75 in.)
Valve Adjustment	0.15 mm (0.006 in.)
Oil Pressure (Minimum at 1250 rpm)	276 kPa (40 psi)
Cylinder Compression (Minimum, with Engine Warm)	620 kPa (90 psi)

ENGINE - GAS (LIQUID-COOLED) SPECIFICATIONS

Fuel/Air System:

Slow Idle Speed	1600 ± 25 rpm
Fast Idle Speed	3550 ± 25 rpm

Repair Specifications

Cylinder Head:

Cylinder Head Flatness (Maximum Warp)	0.050 mm (0.002 in.)
---	----------------------

Valves and Valve Lifters:

Valve Clearance (Intake/Exhaust Cold)	0.15 mm (0.006 in.)
Valve Stem Runout (Maximum)	0.050 mm (0.002 in.)
Valve Stem OD (Exhaust and Intake, Minimum)	6.94 mm (0.273 in.)
Valve Guide ID (Intake and Exhaust)	7.08 mm (0.279 in.)
Valve Spring Free Length (Minimum)	31.0 mm (1.22 in.)
Valve Face Angle	45°
Push Rod Runout (Maximum)	0.5 mm (0.02 in.)

Crank shaft:

Crankshaft Journal Bearing ID: Crankcase	42.14 mm (1.659 in.)
Crankshaft Journal OD (Minimum)	
PTO Side	41.935 mm (1.651 in.)
Flywheel Side	41.935 mm (1.651 in.)
Crankshaft Runout (TIR) (Maximum)	0.05 mm (0.002 in.)
Crankpin OD (Minimum)	39.95 mm (1.573 in.)
Crankpin Width (Maximum)	46.5 mm (1.83 in.)
Connecting Rod:	
Twist (Maximum)	0.15 mm over 100 mm (0.006 over 3.94 in.)
Bend (Maximum)	0.15 mm over 100 mm (0.006 over 3.94 in.)
Connecting Rod Big End Width (Maximum)	22.35 mm (0.88 in.)

Camshaft:

Bearing ID Maximum (Crankcase)	20.081 mm (0.791 in.)
Bearing ID Maximum (Crankcase Cover)	20.081 mm (0.791 in.)
Camshaft Journal Diameter:	
PTO Side (Minimum)	19.927 mm (0.785 in.)
Flywheel Side (Minimum)	19.927 mm (0.785 in.)
Cam Lobe Height (Minimum):	
Intake	33.594 mm (1.323 in.)
Exhaust	33.594 mm (1.323 in.)

Oil Pump:

Inner and outer rotor clearance (Maximum)	0.3 mm (0.012 in.)
Outer rotor OD (Minimum)	40.47 mm (1.593 in.)
Outer rotor thickness (Minimum)	19.830 mm (0.781 in.)
Pump Housing inside diameter (Maximum)	40.801 mm (1.606 in.)
Pump Housing depth (Maximum)	20.230 mm (0.797 in.)
Pump Shaft outside diameter (Minimum)	10.923 mm (0.4300 in.)
Pump Shaft bearing inside diameter (Maximum)	11.072 mm (0.436 in.)

ENGINE - GAS (LIQUID-COOLED) SPECIFICATIONS

Relief Valve Spring length (Minimum) 19.50 mm (0.77 in.)

Cylinder Bore, Pistons and Rings

Cylinder Bore ID:

New 78.00 mm (3.071 in.)
Maximum 78.08 mm (3.074 in.)
Cylinder Bore Out of Round (Maximum) 0.056 mm (0.0022 in.)
Piston Pin Bore ID (Maximum) 19.080 mm (0.751 in.)
Piston Pin OD (Minimum) 18.960 mm (0.747 in.)
Top and Middle Compression Ring-To-Groove Side Clearance 0.15 mm (0.006 in.)
Piston Ring Thickness (Top, Second) (Minimum) 1.40 mm (0.055 in.)
Top and Second Ring End Gap (Maximum) 1.0 mm (0.04 in.)
Oil Ring End Gap (Maximum) 1.2 mm (0.05 in.)
Piston OD (Minimum) 7.70 mm (3.059 in.)

Torque Specifications (Alphabetical)

Note: Use appropriate torque wrench which will read within the inch pound range given, or convert inch pounds to foot pounds as follows: Inch-pounds/12 = Foot-pounds

Air Cleaner Mounting Bolts 9.8 N•m (87 lb-in.)
Camshaft Breather Chamber Cover Bolts 20 N•m (177 lb-in.)
Carburetor to Manifold Mounting Bolts and Nuts (FD671D) 12 N•m (106 lb-in.)
Throttle Body and Intake Pipe Mounting Bolts (FD750D) 12 N•m (106 lb-in.)
Choke Valve Screw (FD671D) 0.95 N•m (8.4 lb-in.)
Throttle Valve Screw 0.90 N•m (8.0 lb-in.)
Water Temperature Sensor (FD750D) 20 N•m (177 lb-in.)
Vacuum Sensor (FD750D) 9.8 N•m (87 lb-in.)
Control Panel Mounting Bolts 5.9 N•m (52 lb-in.)
Crankcase Cover Bolts 22 N•m (195 lb-in.)
Cylinder Head Bolts (Silicone Sealant Applied) 27 N•m (20 lb-ft)
Float Chamber Mounting Screw (Carburetor) 2 N•m (18 lb-in.)
Oil Drain Plug 25 N•m (221 lb-in.)
Engine Flywheel Cover Bolt (M8) 6.9 N•m (61 lb-in.)
Cooling Fan Shaft Nut 20 N•m (177 lb-in.)
Flywheel Bolt 56 N•m (41 lb-ft)
Fuel Shut Off Solenoid Valve (FD671D) Carburetor 7 N•m (61 lb-in.)
Float Chamber Mounting Screw (FD671D) Carburetor) 2 N•m (17 lb-in.)
Governor Arm Clamp Nut 8 N•m (69 lb-in.)
Ignition Coil Bolts 3.4 N•m (30 lb-in.)
Intake Manifold Mounting Bolts 20 N•m (177 lb-in.)
Muffler Flange Nut 20 N•m (177 lb-in.)
Main Jet 0.7 N•m (6 lb-in.)
Oil Pump Cover Plate Mounting Bolts 6 N•m (52 lb-in.)
Oil Pressure Switch 15 N•m (132 lb-in.)
Rocker Arm (Valve Clearance) Adjusting Locknuts 11 N•m (96 lb-in.)
Rocker Arm Bracket Mounting Bolts 22 N•m (195 lb-in.)
Rocker Cover Mounting Bolts 6.9 N•m (61 lb-in.)

ENGINE - GAS (LIQUID-COOLED) SPECIFICATIONS

Connecting Rod Cap Bolts	21 N•m (186 lb-in.)
Spark Plug	25 N•m (221 lb-in.)
Starter Motor Mounting Bolts	20 N•m (177 lb-in.)
Voltage Regulator Screws	3.4 N•m (30 lb-in.)

Special or Required Tools

Special or Required Tools

Tool Name	Tool No.	Tool Use
Photo Tachometer	JT05719	Slow and fast idle adjustment
Cylinder Leakdown Tester	JT03502	Cylinder leakdown test
Crankcase Vacuum Test Kit	JT03503	Crankcase vacuum check
Connector Hose Assembly Pressure Gauge Assembly	JT03349 JT03017 JT03344	Oil pressure test
Compression Gauge	JDM59	Cylinder compression test
Fuel Pump Pressure Test Kit	JDG356	Fuel pump pressure test - FD671D engines
Fitting Pressure Gauge 0-400 kPa (0-60 psi) Fuel Hose	JDG41 JTO7032	Fuel pump pressure test - FD750D engines
Tension Gauge	JDST28	Fan belt tension check
Cooling System Pressure Pump Radiator Test Kit	D05104ST JDG692	Radiator cap and cooling system pressure tests
Lapping Tool		Valve lapping

ENGINE - GAS (LIQUID-COOLED) COMPONENT LOCATION

Component Location

Engine (FD671D)

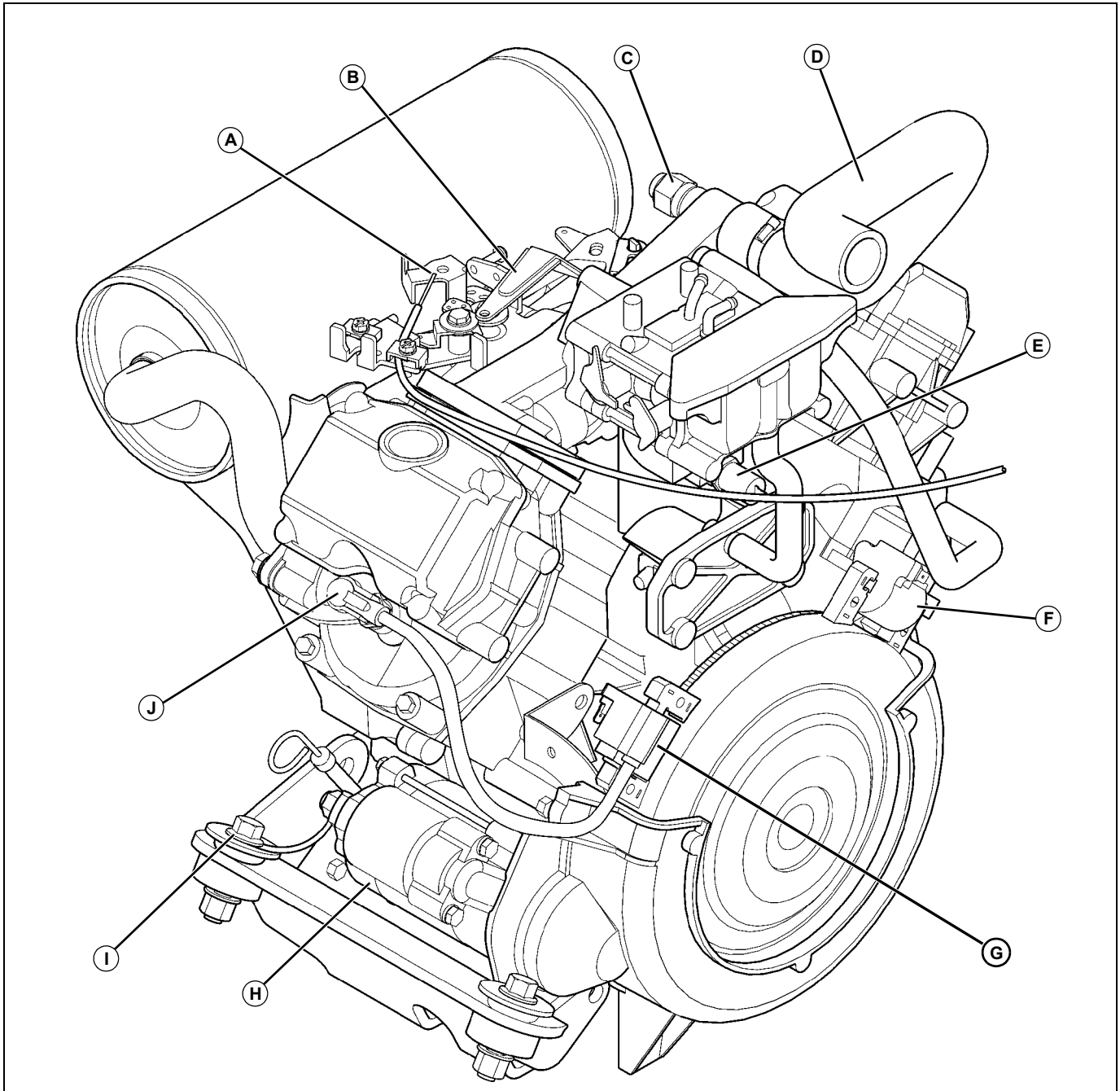

MX14278

- A- Throttle Cable
- B- Governor Arm
- C- Coolant Temperature Sensor
- D- Coolant Hose
- E- Fuel Shutoff Solenoid
- F- Ignition Module #1 Cylinder
- G- Ignition Module #2 Cylinder

- H- Starting Motor
- I- Engine Frame Ground
- J- Spark Plug #2 Cylinder

Note: Number 1 cylinder is on same side of engine as oil filter.

ENGINE - GAS (LIQUID-COOLED) COMPONENT LOCATION

Engine (FD750D)

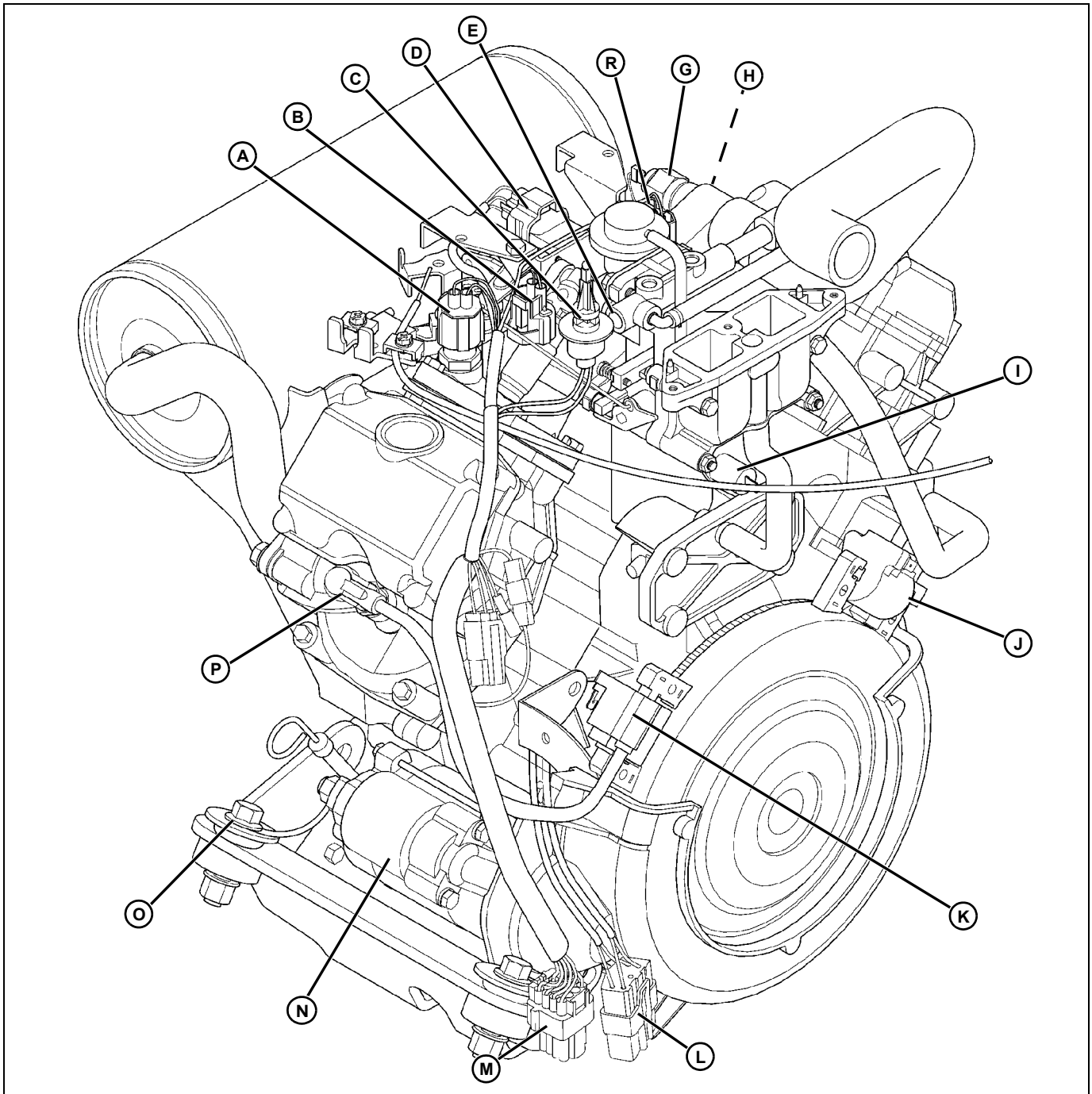

MX14312

- A- Engine Coolant Temperature Sensor
- B- #2 Cylinder Fuel Injector
- C- Air Temperature Sensor
- D- Vacuum Pressure Sensor
- E- Fuel Pressure Relief Screw
- F- #1 Cylinder Fuel Injector
- G- Engine Coolant Temperature Sensor
- H- Engine Oil Pressure Switch (RH Side)
- I- Fuel Shutoff Solenoid

- J- Ignition Module #1 Cylinder
- K- Ignition Module #2 Cylinder
- L- Wiring Harness Connector
- M- Wiring Harness Connector
- N- Starting Motor Solenoid
- O- Frame Ground
- P- Spark Plug #2 Cylinder

Note: Number 1 cylinder is on same side of engine as oil filter.

ENGINE - GAS (LIQUID-COOLED) THEORY OF OPERATION

Theory of Operation

Cooling System Operation

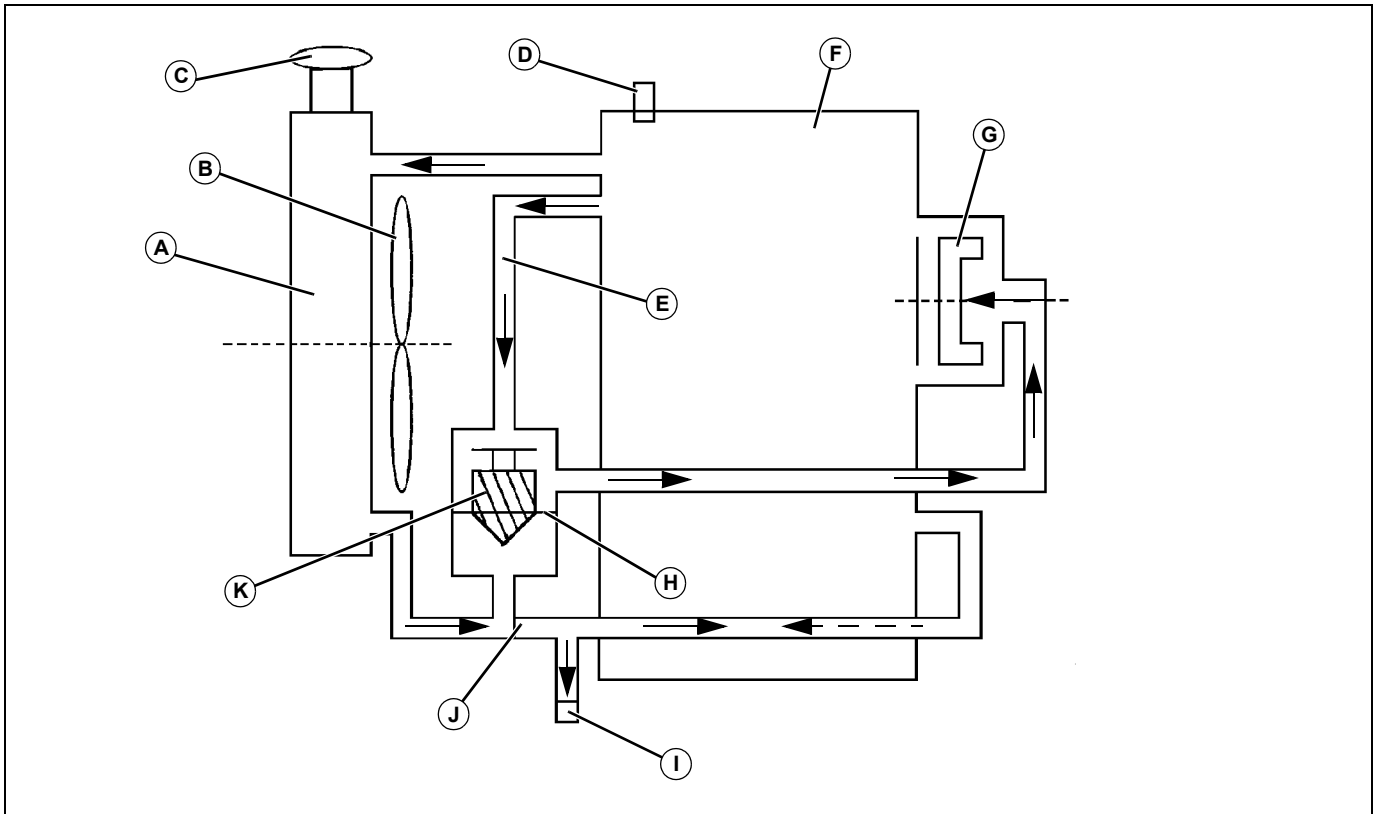

MX14217

- A- Radiator
- B- Cooling Fan
- C- Radiator Cap, maintains radiator pressure at 78 - 98 kPa (11.3 - 14.2 psi)
- D- Thermo Switch, detects at 111°C (232°F)
- E- Bypass Tube
- F- Engine Body
- G- Water Pump (Impeller)
- H- Jiggle Valve
- I- Drain Plug
- J- Valve, One Way
- K- Thermostat, fully open at 95°C (203°F)

Function:

The coolant pump circulates coolant through the cooling system, drawing hot coolant from the engine block, and circulating it through the radiator for cooling.

System Operation:

The impeller-type coolant pump draws coolant from the bottom of the radiator when the thermostat is open, or from the bypass when the thermostat is closed. Coolant from the water pump flows to the water jackets in block, up through cylinder heads, intake manifold, past the coolant temperature sensor and thermostat.

When the engine temperature is below approximately 82°C (180°F), the thermostat is closed and coolant is directed back to the water pump through bypass hose to be recirculated. This allows the engine to warm up to operating temperature quickly.

When the engine temperature is approximately 82°C (180°F), the thermostat begins to open and is fully open at 95°C (203°F). Coolant from the water jackets and cylinder heads now flow through the thermostat to the radiator, which is cooled by the radiator fan. The fan is driven by a belt off the crankshaft pulley. If the engine coolant temperature raises to 111°C (232°F), a thermo switch detects this, and turns on a warning light on the dash, warning you of a potentially dangerous overheating situation.

The radiator cap maintains a pressure of 78 - 98 kPa (11.3 - 14.2 psi) inside the radiator, which actually raises the boiling point of the coolant. The radiator cap contains a pressure valve and a vacuum valve. When the coolant is hot and pressure is above 98 kPa (14.2 psi), the pressure valve opens, allowing some coolant to flow to the recovery tank. After the engine is stopped, the coolant cools and the pressure inside the radiator decreases. The pressure difference between the radiator and recovery tank forces the pressure valve open and some coolant from the recovery tank flows back to the radiator.

ENGINE - GAS (LIQUID-COOLED) THEORY OF OPERATION

Fuel and Air System Operation

Function:

The fuel system supplies fuel to the engine for combustion. The air intake system filters air needed for combustion.

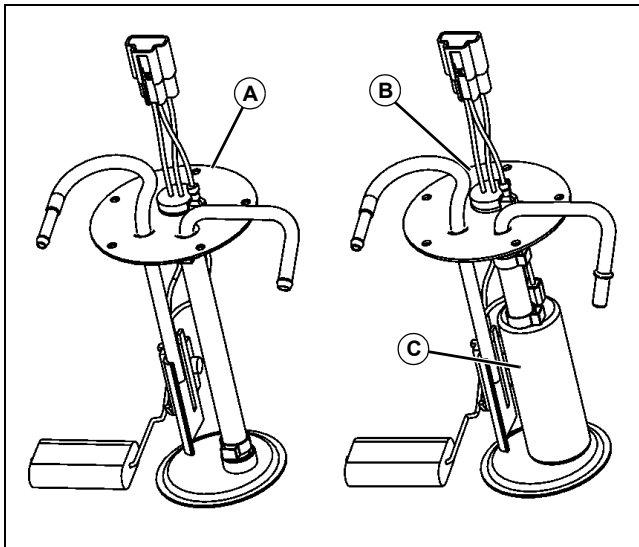

MX14324

The fuel tank holds the fuel pick-up and fuel sensor assembly. The carbureted engine has a fuel pump mounted to the side of the engine. The fuel pick-up (A) consists of a fuel pick-up tube and a float type fuel sensor. The fuel pump draws fuel through the fuel pump screen. Low pressure fuel from the fuel pump flows through the fuel shut-off valve and in-line fuel filter to the carburetor. Fuel pressure is maintained at the carburetor inlet needle until the float allows more fuel in the bowl.

The fuel injected engine has pressurized fuel supplied to the engine. The fuel pick-up (B) consists of a fuel pick-up tube with an in-line electric fuel pump (C).

System Operation - Fuel Injection:

An electric fuel pump (C) mounted inside the fuel tank provides pressurized fuel to the carburetor. The fuel pump uses the fuel for lubrication and cooling. The fuel shutoff solenoid shuts off fuel to the main jet, preventing gas fumes from escaping into the air for emission control, while the fuel cap is vented for releasing any increased pressure within the fuel tank.

The ignition delay module is used with the fuel shut-off solenoid to prevent backfire. The ignition delay module allows the spark plugs to fire for one additional second after the key switch is turned off to burn any remaining fuel in the cylinder. When the key switch is turned off, the fuel shut-off solenoid is de-energized.

Air enters the air filter through the side panel screen and air filter inlet hose. The breather hose vents crankcase fumes into the carburetor for burning to decrease emissions.

Fuel Injection Air System Components and Operation (FD750D)

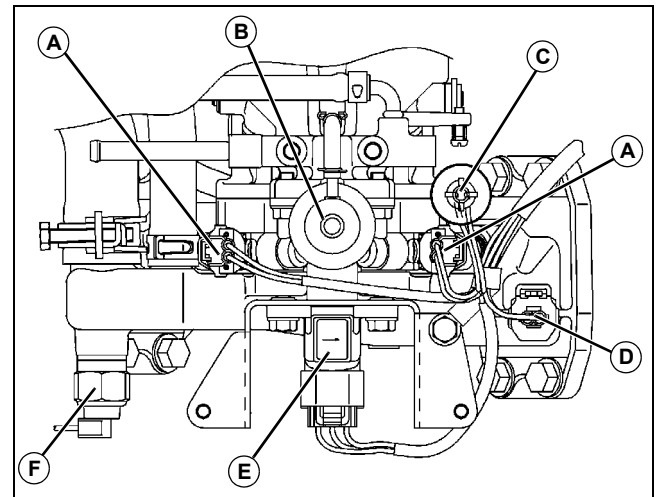

MX14223

- A- Fuel Injectors
- B- Fuel Pressure Regulator
- C- Air Temperature Sensor
- D- Water Temperature Sensor
- E- Vacuum Pressure Sensor
- F- Thermo Switch

Function:

The fuel injection system supplies pressurized fuel to the fuel injectors for combustion. The air intake system filters air needed for combustion.

System Operation:

An electric fuel pump mounted inside the fuel tank provides pressurized fuel to the fuel injectors (A). The fuel pump uses the fuel for lubrication and cooling. The fuel pump and fuel injectors are controlled by the fuel injection module computer. The controller monitors engine operating and environmental conditions to calculate the amount of fuel to inject. The fuel pump draws fuel through the fuel pump screen. High pressure fuel from the fuel pump flows through the in-line fuel filter to the fuel pressure regulator (B) and fuel injector. The fuel injector is a solenoid operated type valve with single point injection. Fuel is injected into the throttle body when the solenoid is energized by the controller. Fuel pressure is controlled by the fuel pressure regulator. The regulator is an overflow type regulator that maintains fuel pressure at the fuel injector at a constant 175 kPa (25 psi). Excess fuel flows through the regulator valve and fuel return hose to the fuel tank. The fuel shutoff solenoid shuts off fuel to the main jet, preventing gas fumes from escaping into the air for emission control, while the fuel cap is vented for releasing any increased pressure within the fuel tank.

ENGINE - GAS (LIQUID-COOLED) THEORY OF OPERATION

The throttle control lever, which is connected to the throttle lever and the governor lever, controls engine rpm. The governor lever is connected to the throttle valve inside the throttle body. Slow idle is adjusted by turning the slow idle stop screw and fast idle is adjusted by moving the throttle control plate.

Air enters the air filter through the side panel screen and air filter inlet hose. The primary and secondary elements filter the air before entering the throttle body. The breather hose vents crankcase fumes into the throttle body for burning to decrease emissions. A small amount is always present due to some restriction of air movement through the filter elements. The vacuum increases as the filter elements become plugged.

Fuel Pressure Regulator Operation (FD750D)

Function:

Maintains a constant differential in pressure between fuel pressure at the injector and air pressure in the throttle body. Therefore, the amount of fuel injected is determined by the opening time of the injector.

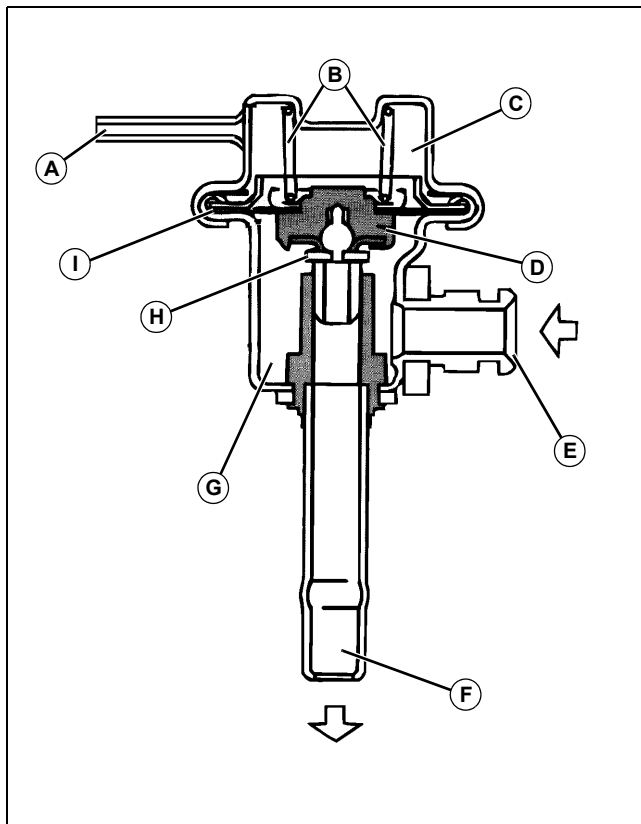

M45334

- A- To Throttle Body
- B- Spring
- C- Spring Chamber
- D- Valve Support

- E- Inlet from Injector
- F- Return to Tank
- G- Fuel Chamber
- H- Valve
- I- Diaphragm

System Operation:

The pressure regulator is an overflow type of regulator. The spring chamber is connected to the throttle body to insure that they are operating at the same air pressure. High pressure fuel from the injector flows to the pressure regulator inlet and fills the fuel chamber. A hose from the vacuum inlet is connected to the intake manifold. This allows the air pressure in the spring chamber and intake manifold to be equal.

When intake manifold vacuum increases, the spring chamber vacuum also increase and overcomes spring tension, allowing the diaphragm to move upward. With the valve connected to the diaphragm, the valve moves upward and allows more fuel to flow out of the outlet and return to the fuel tank. This lowers the fuel pressure. As intake manifold vacuum decreases, the spring chamber vacuum decreases and the spring returns the diaphragm to the original position. The valve restricts fuel flow to return and fuel pressure increases.

Governor Operation

System Operation:

The governor controls engine speed. Governed engine speed is a balance between governor spring tension, set by the throttle control, and actual engine speed, countered by centrifugal force of the governor flyweights. As tension is applied to governor spring, governor linkage opens carburetor/fuel injection throttle shaft and plate, increasing engine rpm. As the engine speed increases, flyweight assembly (driven by the crankshaft gear) pushes on governor arm, rotating governor shaft and lever, moving throttle shaft, closing throttle plate slightly and reducing rpm to governed operating speed. If a heavy load is encountered, engine speed drops, as does the governor assembly speed. Flyweights retract and allow shaft arm to move governor shaft and lever in opposite direction to open throttle plate and allow more air into venturi to draw in more fuel until engine peak operating speed is recovered. Springs provide a smooth yet responsive transitional control.

Important: Avoid Damage! Flyweight assembly shaft is pressed into crankcase cover and is not serviceable. Therefore, if it is damaged or pulled loose, the crankcase cover MUST BE replaced.

ENGINE - GAS (LIQUID-COOLED) THEORY OF OPERATION

Lubrication System Operation

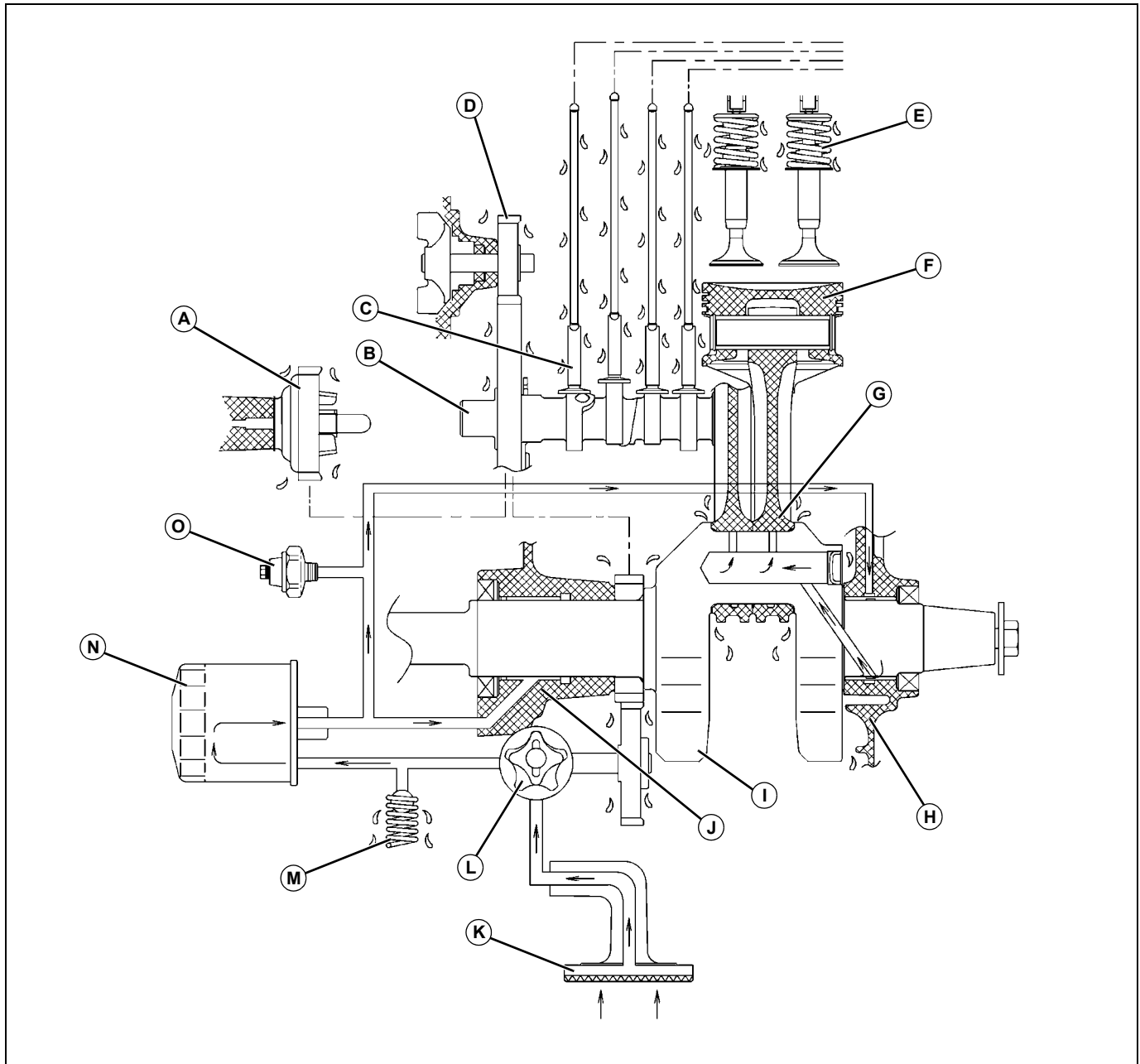

MX14218

System Operation:

A positive displacement gerotor pump (L) is used to pressurize the lubrication system. The lubrication system is protected by an oil pressure relief valve (M), low pressure switch (O), and an oil filter (N) with bypass.

The oil pump (L) draws oil from the sump through a filter screen (K). Pressure oil from the pump flows to the oil pressure relief valve (M). Oil pressure reading should be **276 kPa (40 psi) minimum**. If oil pressure exceeds **310 kPa (45 psi)**, the relief valve (M) opens allowing oil to return to sump. The relief valve is not adjustable.

Pressure oil from the relief valve flows to the oil filter (N). The filter contains a bypass valve, which opens if the element becomes plugged to insure engine lubrication.

An oil pressure switch (O) mounted above the oil filter turns on a warning light if oil pressure is below **98 kPa (14.2 psi)**. Filtered pressure oil flows through a passage in the oil sump to the crankshaft main bearing (J) (PTO side).

Drilled passages in the crankshaft (I) distribute oil from the main bearing to the connecting rod (G) journals and crankshaft main bearing (H) (flywheel side). A drilled passage in the connecting rods allows oil from the connecting rod journal to lubricate the piston (F) and cylinder walls and camshaft (B), tappets (C), governor gear (A), water pump gear (D) and rocker arms and valves (E).

ENGINE - GAS (LIQUID-COOLED) THEORY OF OPERATION

Throttle Body Operation (FD750D)

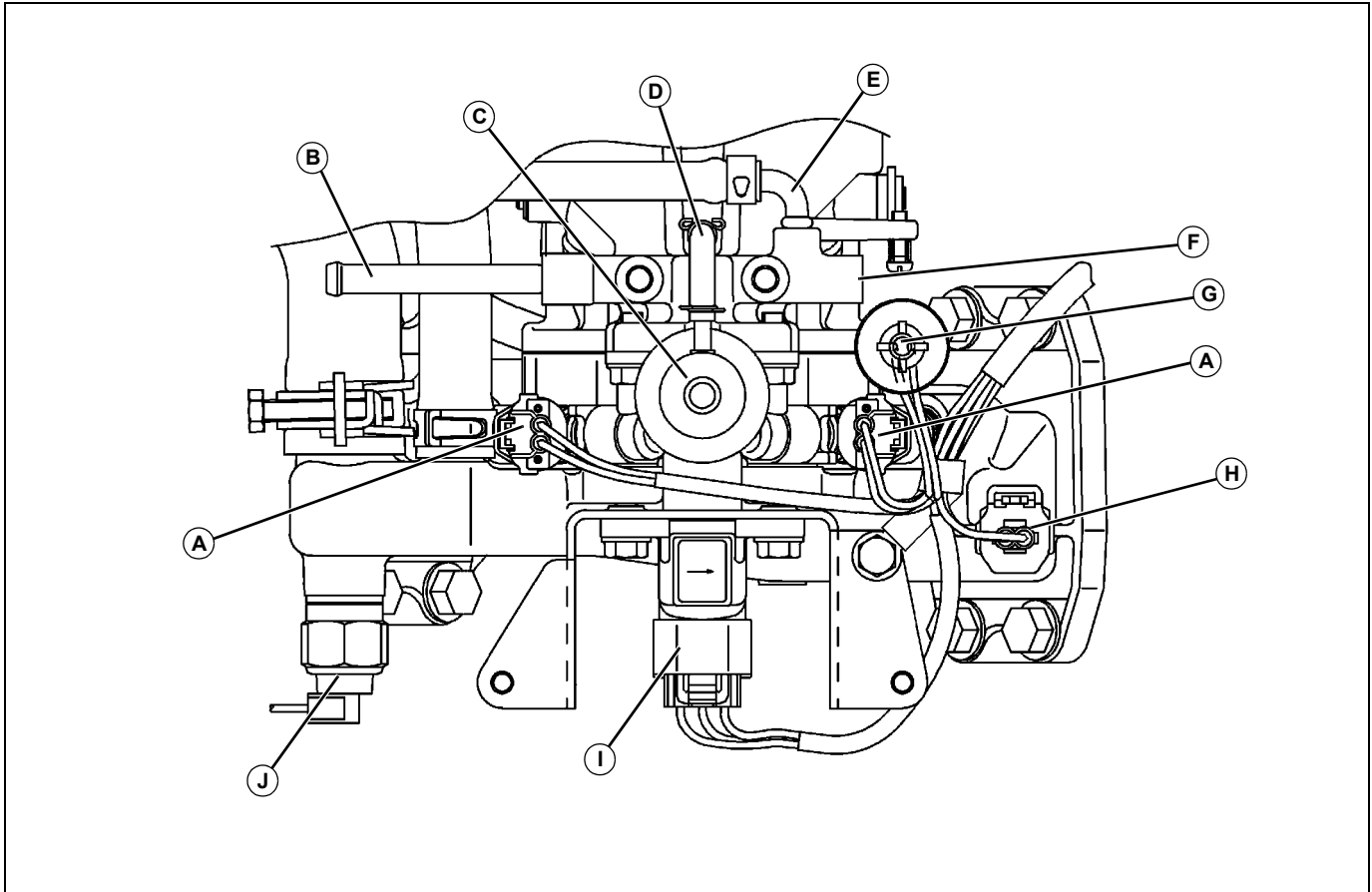

MX14223

- A- Fuel Injectors
- B- Fuel Inlet
- C- Fuel Pressure Regulator
- D- Vacuum Hose
- E- Fuel Return Hose
- F- Fuel Pressure Relief Screw
- G- Air Temperature Sensor
- H- Water Temperature Sensor
- I- Vacuum Pressure Sensor
- J- Thermo Switch

Excess fuel not used by the injector flows through the pressure regulator (C) back to the fuel tank.

The FD750D has an extra passage [fuel pressure relief screw (F)] in the throttle body that allows for a means to relieve the fuel pressure in the fuel lines before any work is done on the system.

Function:

Injects and atomizes the fuel into the intake air for the proper combustion.

System Operation:

An electric fuel pump, controlled by the computer, supplies fuel to the inlet (B) of the throttle body to the injector. The fuel pressure regulator holds the fuel under pressure in the injectors (A). The computer receives signals from the throttle sensor and other sensors then controls the time the injector is open. The injector injects the atomized fuel into the throat of the throttle body.

ENGINE - GAS (LIQUID-COOLED) DIAGNOSTICS

Diagnostics

Engine Diagnosis



Caution: Avoid Injury! Engine radiator fluid is extremely hot during operation. The engine may start to rotate at any time. Keep hands away from all moving parts when testing.

Symptom: Engine Starting Problems

Problem	Cause - Solution
1. Engine will not crank?	a. No: Go to next step. b. Yes: Battery weak or discharged. Fusible link defective. Check key switch or wiring. Starter solenoid defective. Starter motor defective.
2. Engine will not start; plug wet?	a. No: Go to next step. b. Yes: Mixture too rich. Clean under engine shrouding. Check spark plug gap and spark (see Electrical section). Inlet needle and seat sticking (FD671D engine). Clean carburetor (FD671D engine).
3. Engine is hard to start when cold?	a. No: For additional tests, see "Engine Tests" on page 38. b. Yes: Mixture too rich. Mixture too lean. Clean under engine shrouding. Choke is not completely shut, adjust choke (FD671D engine). Inlet needle and seat sticking (FD671D engine). Clean carburetor (FD671D engine).

Symptom: Engine Starting Problems

Problem	Cause - Solution
4. Engine cranks but will not start?	a. No: Go to next step. b. Yes: Battery weak or discharged. Fuel shut-off valve closed (in-line valve). Fuel shut-off solenoid not allowing fuel into main jet (FD671D engine). Fuel shut-off solenoid not allowing fuel into fuel injector (FD750D engine). Improper use of choke (FD671D engine). Float level too high (FD671D engine). Check spark (See Electrical section). Weak or faulty spark plug. Faulty high tension leads. Faulty ignition module (FD671D engine). Faulty fuel injection module (FD750D engine). Faulty ignition coil. Faulty pulsar coil. Contaminated fuel or faulty fuel supply system. Defective fuel pump. Air being drawn in through a hole in fuel line(s). Clogged fuel line or filter. Fuel tank vent line clogged. Air filter restricted. Defective head gasket. Cylinder head loose. Broken valve spring. Warped cylinder head. Poor compression. Worn piston/piston rings stuck or not seated. Worn cylinder bore. Worn or burned valves, or improper clearance.

ENGINE - GAS (LIQUID-COOLED) DIAGNOSTICS

Symptom: Engine Performance Problems

Problem	Cause - Solution
1. Loss of power?	a. No: Go to next step. b. Yes: Low oil level. Too much oil in crankcase. Carburetor out of adjustment (FD671D engine). Air/Fuel passages plugged. Carbon deposits in exhaust pipe/muffler. Carbon deposits in combustion chamber. Weak or faulty spark plug. Faulty high tension leads. Faulty ignition module (FD671D engine). Faulty fuel injection module (FD750D engine). Faulty ignition coil. Faulty pulsar coil. Contaminated fuel or faulty fuel supply system. Defective fuel pump. Air being drawn in through a hole in fuel line(s). Clogged fuel line or filter. Fuel tank vent line clogged. Vapor lock. Air filter restricted. Defective breather valve. Cylinder head loose. Mixture too lean. Check and clean air cleaner. Adjust idle mixture and check engine performance (FD671D engine). Choke is not completely open, adjust choke (FD671D engine). Clean carburetor (FD671D engine). Worn or burned valves, or improper clearance. Broken valve spring. Warped cylinder head. Defective head gasket. Poor compression. Worn piston/piston rings stuck or not seated. Worn cylinder bore.

Symptom: Engine Performance Problems

Problem	Cause - Solution
2. Engine runs erratically?	a. No: Go to next step. b. Yes: Carburetor out of adjustment (FD671D engine). Lack of coolant. Governor linkage out of adjustment. Faulty governor spring. Governor gear assembly binding or broken. Check spark (See Electrical section). Carburetor flange loose or leaking at gasket (FD671D engine). Throttle body flange loose or leaking at gasket (FD750D engine). Carburetor body and throttle shaft worn (FD671D engine). Throttle body and throttle shaft worn (FD750D engine). Weak or faulty spark plug. Faulty high tension leads. Faulty ignition module (FD671D engine). Faulty fuel injection module (FD750D engine). Faulty ignition coil. Faulty pulsar coil. Contaminated fuel or faulty fuel supply system. Defective fuel pump. Air being drawn in through a hole in fuel line(s). Clogged fuel line or filter. Fuel tank vent line clogged. Vapor lock. Oil leakage around governor shaft. Defective oil seal.
3. Engine misses at high rpm?	a. No: Go to next step. b. Yes: Check spark (See Electrical section). Weak or faulty spark plug. Faulty high tension leads. Faulty ignition module (FD671D engine). Faulty fuel injection module (FD750D engine). Faulty ignition coil. Faulty pulsar coil. Carburetor out of adjustment (FD671D engine). Clogged fuel line or filter. Fuel tank vent line clogged. Defective fuel pump. Warped cylinder head.

ENGINE - GAS (LIQUID-COOLED) DIAGNOSTICS

Symptom: Engine Performance Problems

Problem	Cause - Solution
4. Engine misses at low rpm?	<p>a. No: Go to next step.</p> <p>b. Yes: Carburetor out of adjustment (FD671D engine). Air/Fuel passages plugged. Air being drawn through carburetor or intake manifold flanges (FD671D engine). Air being drawn through throttle body or intake manifold flanges (FD750D engine). Incorrect timing gear alignment. Check spark (See Electrical section). Weak or faulty spark plug. Faulty high tension leads. Faulty ignition module (FD671D engine). Faulty fuel injection module (FD750D engine). Faulty ignition coil. Faulty pulsar coil. Worn or burned valves, or improper clearance. Warped cylinder head.</p>
5. Engine rpm low or engine stalls?	<p>a. No: Go to next step.</p> <p>b. Yes: Battery weak or discharged.</p>
6. Engine speed unstable (surging)?	<p>a. No: Go to next step.</p> <p>b. Yes: Mixture too lean. Clean under engine shrouding. Adjust idle mixture and check engine performance (FD671D engine). Clean carburetor (FD671D engine).</p>
7. Engine is sluggish?	<p>a. No: Go to next step.</p> <p>b. Yes: Mixture too rich. Check and clean air cleaner. Adjust idle mixture and check engine performance (FD671D engine). Choke is not completely open, adjust choke (FD671D engine). Clean carburetor (FD671D engine).</p>
8. Black, smoky exhaust?	<p>a. No: Go to next step.</p> <p>b. Yes: Check spark plug gap and spark (see Electrical section). Mixture too rich. Check and clean air cleaner. Choke is not completely open, adjust choke (FD671D engine).</p>

Symptom: Engine Performance Problems

Problem	Cause - Solution
9. Spark plug fouled black?	<p>a. No: Go to next step.</p> <p>b. Yes: Check spark plug gap and spark (see Electrical section). Mixture too rich. Check and clean air cleaner. Adjust idle mixture and check engine performance (FD671D engine). Choke is not completely open, adjust choke (FD671D engine). Inlet needle and seat sticking (FD671D engine).</p>
10. Spark plug burned white?	<p>a. No: Go to next step.</p> <p>b. Yes: Check spark plug gap and spark (see Electrical section). Mixture too lean. Clean under engine shrouding. Clean carburetor (FD671D engine).</p>
11. Runs better without air cleaner?	<p>a. No: Go to next step.</p> <p>b. Yes: Mixture too rich. Check and clean air cleaner.</p>
12. Runs worse when warm?	<p>a. No: Go to next step.</p> <p>b. Yes: Mixture too rich. Check and clean air cleaner. Adjust idle mixture and check engine performance (FD671D engine). Choke is not completely open, adjust choke (FD671D engine). Inlet needle and seat sticking (FD671D engine).</p>
13. Engine overheats?	<p>a. No: Go to next step.</p> <p>b. Yes: Mixture too lean. Clean under engine shrouding. Water pump nylon impeller defective.</p>
14. Engine backfires?	<p>a. No: Go to next step.</p> <p>b. Yes: Carburetor out of adjustment (FD671D engine). Check spark (See Electrical section). Faulty pulsar coil. Air being drawn in through a hole in fuel line(s). Cylinder head loose. Warped cylinder head. Defective head gasket. Intake valve burned or sticking.</p>

ENGINE - GAS (LIQUID-COOLED) DIAGNOSTICS

Symptom: Engine Performance Problems

Problem	Cause - Solution
15. Engine knocks?	a. No: Go to next step. b. Yes: Excessive engine load. Faulty ignition module (FD671D engine). Faulty fuel injection module (FD750D engine). Contaminated fuel or faulty fuel supply system. Defective head gasket.
16. Engine overheats?	a. No: For additional tests, see "Engine Tests" on page 38. b. Yes: Lack of coolant. Excessive engine load. Fan belt slippage. Defective radiator hose or clamp. Improper or defective radiator cap. Broken or missing fan shroud. Defective radiator. Loose stud bolts and cap screw. Cracked or porous casting. Damaged water pump seals. Improperly installed gasket. Warped cylinder head. Broken valve spring. Defective head gasket. Worn or burned valves, or improper clearance.

Symptom: Engine fuel/oil/coolant problems

Problem	Cause - Solution
1. Coolant leakage?	a. No: For additional tests, see "Engine Tests" on page 38. b. Yes: Lack of coolant. Improper or defective radiator cap. Defective radiator hose or clamp. Defective radiator. Cracked or porous casting. Loose stud bolts and cap screw. Engine overheating. Damaged water pump seals. Improperly installed gasket. Cylinder head loose.

Symptom: Engine fuel/oil/coolant problems

Problem	Cause - Solution
2. Excessive oil consumption?	a. No: Go to next step. b. Yes: Too much oil in crankcase. Incorrect oil viscosity. Drain-back in breather chamber plugged. Defective breather valve. Worn valve stems(s) or valve guide(s). Plugged oil ring groove. Poor compression. Worn piston/piston rings stuck or not seated. Worn cylinder bore.
3. Excessive fuel consumption?	a. No: Go to next step. b. Yes: Check spark (See Electrical section). Weak or faulty spark plug. Faulty high tension leads. Faulty ignition module (FD671D engine). Faulty fuel injection module (FD750D engine). Faulty ignition coil. Faulty pulsar coil. Improper use of choke (FD671D engine). Air filter restricted. Carburetor out of adjustment (FD671D engine). Float level too high (FD671D engine). Cylinder head loose. Broken valve spring. Worn or burned valves, or improper clearance. Poor compression. Worn piston/piston rings stuck or not seated. Worn cylinder bore.

ENGINE - GAS (LIQUID-COOLED) DIAGNOSTICS

Engine Tests

Test Procedure - A:

Test Conditions:

- Machine parked on level surface.
- PTO Switch off
- Key switch off unless indicated otherwise.
- Spark plug connected to D-05351ST Spark Tester

Engine

1. When checking dipstick, oil at proper level and viscosity? No leakage? Clean oil and filter?

Yes: Go to next step.

No: Change oil and inspect for source of contamination.

No: Change oil filter.

No: Check gaskets, seals, plugs, cylinder head, block, and intake manifold and breather.

2. Air filter outlet hose not cracked; clamps tight?

Yes: Go to next step.

No: Replace hose and/or tighten clamps.

3. Air filter elements not plugged? Air filter housing sealed; no dirt tracking inside filter element?

Yes: Go to next step.

No: Replace element or housing.

4. Air filter restriction indicator not leaking?

Yes: Go to next step.

No: Replace indicator.

5. Does fuel shutoff solenoid pull in and stay in when key is returned to "ON"? (Listen for clicking as key is cycled.)

Yes: Go to next step.

No: If solenoid will not pull in and hold in, see Fuel Shutoff Solenoid Circuit Diagnosis in Electrical section.

6. Check hand throttle control lever linkage. Full movement of governor control arm from idle to full speed?

Yes: Go to next step.

No: Repair; replace or adjust linkage.

7. Check intake and exhaust valves. Valve clearance within specification (engine cold)? Valves not sticking?

Yes: Go to next step.

No: Adjust valves. See "Tests and Adjustments" in this

section.

No: Check valve guides and stems.

8. Is fuel is reaching injectors (FD750D)? (Crack fuel injection lines at injectors. Crank engine. Be sure fuel shutoff solenoid has pulled in. Fuel leaks out.)

Yes: Go to next step.

No: No fuel present: Check fuel shutoff valve is open, fuel level in tank, inspect filter/separator element. Test fuel pump.

9. Check flywheel and starting motor: Minimum cranking rpm within specification?

Yes: Go to next step.

No: See "Starter Amp Draw Test" in Electrical section.

10. Carburetor choke and governor linkage, (FD671D). Linkage not binding and adjusted correctly?

Yes: Go to next step.

No: Repair, replace or adjust linkage.

11. Carburetor - fuel filter, fuel pump, and carburetor bowl drain screw (key switch on), (FD671D). Fuel level increases in filter? Fuel pump operating - listen for humming sound near fuel cap? Fuel present in float bowl when screw is opened?

Yes: Go to next step.

No: See "Shutoff Circuit Diagnosis" in the Electrical section.

No: Test fuel pump pressure and flow.

No: Check carburetor for debris.

12. Fuel injection pump static timing test, (FD750D). Timing should be correct? (Remove pump as the LAST possible solution.)

Yes: Go to next step.

No: Have injection pump static timing adjustment performed by a qualified service repair shop. See "Tests and Adjustments" in this section.

13. Carburetor/Throttle body (engine running). Low idle at 1550 rpm? High idle at 3600 rpm?

Yes: Go to next step.

No: See "Low Idle Speed Adjustment" on page 42 and "High Idle Speed Adjustment" on page 42 in this section.

14. Engine runs smoothly through out rpm range with low smoke and good power?

Yes: Go to next step.

No: Adjust governor.

15. Test oil pressure switch port. Minimum oil pressure

ENGINE - GAS (LIQUID-COOLED) DIAGNOSTICS

within specifications?

Yes: Go to next step.

No: Test engine oil pressure. (See "Engine Oil Pressure Test" on page 46 in this section.)

16. Thermostat opening temperature within specifications?

Yes: Go to next step.

No: Perform thermostat opening test. See "Tests and Adjustments" in this section.

17. Muffler not restricted?

Yes: Go to next step.

No: Replace muffler.

18. When performing cylinder compression test: Cylinder compression within specification? Pressure difference between cylinders within specification?

Yes: Engine tests completed.

No: Rebuild engine.

smelling; no water in fuel?

Yes: Go to next step.

No: Drain and clean fuel tank. Add fresh fuel.

2. Fuel pump filter and in-line filter free of debris?

Yes: Go to next step.

No: Replace filters.

3. Fuel hoses not cracked or leaking?

Yes: Go to next step.

No: Replace.

4. Fuel hose clamps tight?

Yes: Go to next step.

No: Replace or tighten.

5. Fuel tank does not have vacuum?

Yes: Fuel tank, pump, lines and filter tests completed.

No: Replace vented fuel cap.

Coolant tank and radiator

1. Coolant level between marks on tank when engine is warm? Coolant in radiator full to top?

Yes: Go to next step.

No: Add proper coolant mix.

2. Coolant not contaminated with oil, fuel or discolored brown?

Yes: Go to next step

No: Drain and flush system. Check for source of contamination.

3. Radiator screen free of debris?

Yes: Go to next step.

No: Clean or replace.

4. Hoses not cracked or leaking; clamps and radiator cap tight?

Yes: Go to next step.

No: Pressure test radiator and cap.

5. Water pump/alternator belt tight; not glazed or cracked?

Yes: Go to next step.

No: Replace and adjust belt tension.

6. Fan blades not damaged or warped?

Yes: Coolant tests completed.

No: Replace fan.

Fuel tank, pump, lines and filter

1. Fuel level correct; not contaminated or stale

ENGINE - GAS (LIQUID-COOLED) TESTS AND ADJUSTMENTS

Tests and Adjustments

Throttle Lever Adjustment

Reason:

To achieve smooth throttle lever movement with enough tension to maintain throttle setting.

Test Equipment:

- Spring Scale

Procedure:

1. Connect a scale near the end of the throttle lever.
2. Move throttle lever to slow idle position.



MX14234A

3. Adjust friction disks by tightening or loosening lock nut (A) until throttle lever movement in forward direction is **18 - 35 N (4 - 8 lb force)**.

Note: Make sure throttle cable is not binding or stuck.

Throttle Cable Adjustment

Reason:

To insure that the throttle lever cable moves the governor linkage from slow to fast idle position.

Procedure:

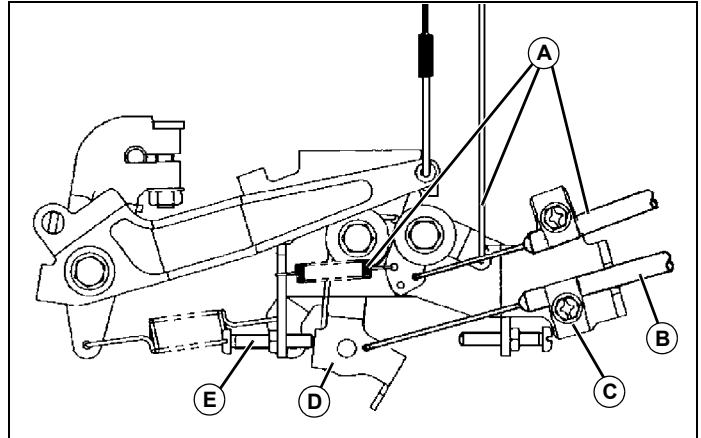

MX14227

Picture Note: FD671D engine shown; FD750D engine does not have choke assembly parts (A).

1. Set the throttle lever in the slow idle position. Check that the throttle control lever (D) contacts the idle speed adjustment screw (E) at the slowest throttle lever setting.
2. If the throttle control lever (D) is not touching the screw (E) at the slowest setting, loosen the throttle cable clamp (C). Pull throttle cable (B) to left. When the control lever contacts the control plate idle adjustment screw, retighten the cable clamp.
3. Set the throttle lever to the fastest idle position and check that the throttle control lever is advancing to the full open position.
4. If the control lever is not advancing to the fully open position, loosen the cable clamp and readjust cable.
5. If the cable cannot be adjusted to obtain a fully open throttle lever position at fastest idle while maintaining contact with the adjustment screw at lowest idle position, it will be necessary to adjust the control plate idle speed adjustment screw.
6. Turn the idle adjustment screw (E) clockwise until it contacts the throttle control lever when set in the slow idle position. After completing the idle screw adjustment, check to make certain the motor is maintaining a 1550 RPM governed low idle setting. Follow the Low Idle Speed Adjustment sequence in this chapter if corrections are necessary.

ENGINE - GAS (LIQUID-COOLED) TESTS AND ADJUSTMENTS

Choke Adjustment (FD671D)

Reason:

To make sure the choke plate is fully closed when the choke lever is in the full choke position. Correct adjustment also makes sure choke is completely open in the fast idle position.

Procedure:

Note: Adjust throttle cable before adjusting choke.

1. Remove air cleaner assembly.
2. Move choke lever forward to full choke position and check that choke butterfly in carburetor is fully closed.

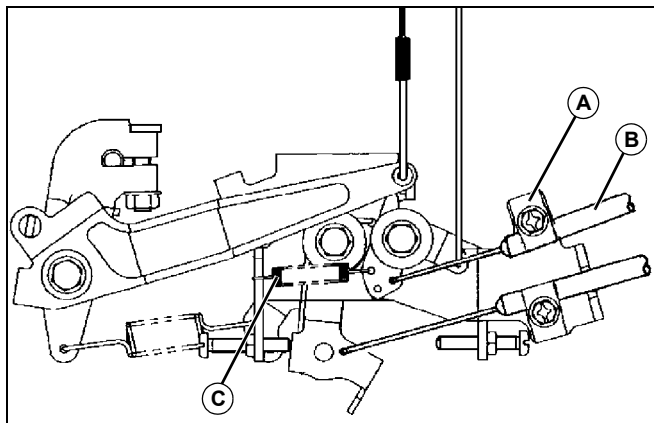

MX14227

3. If adjustment is necessary, loosen the choke cable clamp (A) and move the cable (B) to obtain a fully closed position. Retighten the cable clamp.
4. Release the choke lever and make certain the return spring (C) on the governor control plate is returning the choke butterfly to the fully open position.
5. Reinstall air cleaner assembly and check choke operation while starting machine.

Governor Adjustment

Reason:

To make sure the governor shaft contacts the flyweight plunger when the engine is stopped.

Note: Adjust throttle cable before adjusting governor linkage.

Procedure:

Note: It is not necessary to remove the throttle or choke cables from the governor plate assembly to reach the governor arm. The governor plate can be swung away with the cables installed when accessing the governor arm components.

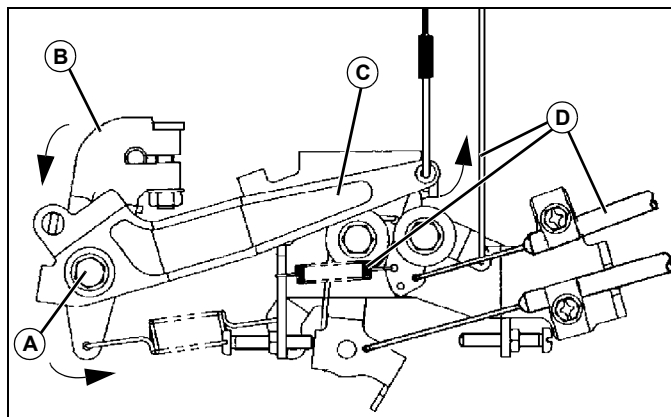

MX14227

Picture Note: FD671D engine shown; FD750D engine does not have choke assembly parts (D).

1. Loosen bolt (A), and fully turn the bracket (B) counterclockwise and hold it there.
2. Turn the top end of the governor arm (C) counterclockwise to fully open the carburetor/EFI throttle valve and tighten the bolt (A).

ENGINE - GAS (LIQUID-COOLED) TESTS AND ADJUSTMENTS

Low Idle Speed Adjustment

Reason:

To set engine slow idle mixture rpm.

Equipment:

- JTO5719 Photo Tachometer

Procedure:

1. Disconnect all external loads from engine.
2. Put reflective tape on blower housing screen.
3. Start and run engine at MEDIUM idle for five minutes.



Caution: Avoid Injury! Engine will be HOT. Be careful not to burn skin.

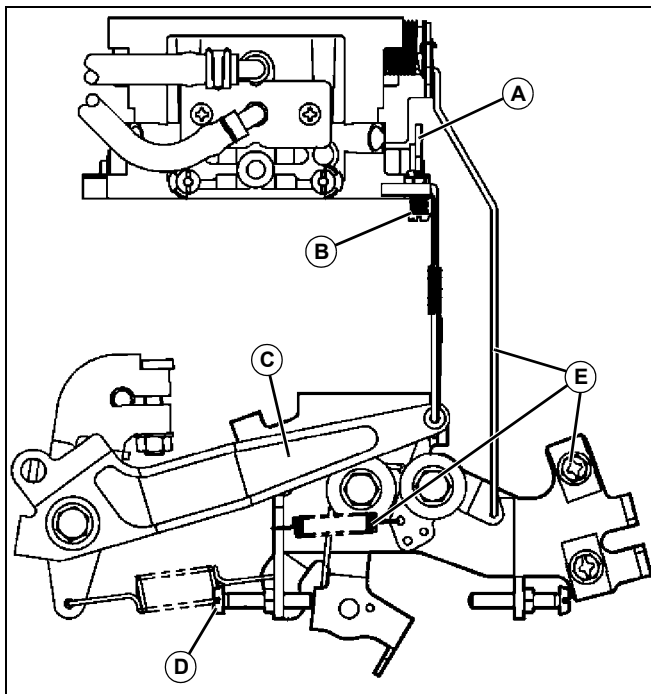

MX14226

Picture Note: FD671D engine shown; FD750D engine does not have choke assembly parts (E).

4. Move throttle lever on dash to idle position. Hold the throttle lever (A) on the carburetor in the closed position, turn governor arm (C) clockwise all the way.
5. Adjust the low idle speed screw (B) until the engine idles at 1450 rpm (carburetor idle rpm). Use the photo tachometer to check engine rpm at the blower housing screen.
6. Release the throttle lever and adjust the low idle speed set screw (D) on the control plate to obtain a 1550 rpm governed low idle speed.

High Idle Speed Adjustment

Reason:

To set engine high idle mixture and rpm.

Equipment:

- JTO5719 Photo Tachometer

Procedure:

Note: High idle speed adjustment should be made after the low idle speed adjustment is performed.



Caution: Avoid Injury! Always keep hands clear of moving parts.

1. Start and run engine at MEDIUM idle for five minutes.

Important: Avoid Damage! Do Not adjust high idle speed with air cleaner removed.

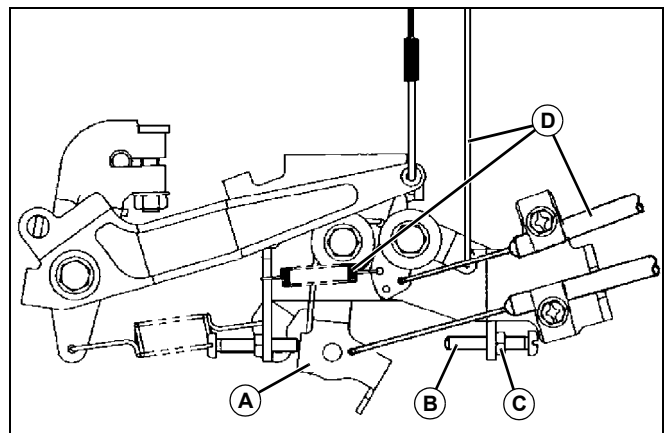

MX14227

Picture Note: FD671D engine shown; FD750D engine does not have choke assembly parts (D).

2. Loosen the lock nut (C), and unscrew the high idle set screw (B) a few turns.
3. Use a photo tachometer to check engine rpm at the blower housing screen.
4. Move the throttle lever on dash to obtain the a **3600 RPM** high idle speed and leave it there.
5. Turn the high idle set screw (B) so that the end of it just touches the speed control lever (A). Tighten the lock nut (C).
6. Recheck the idle speed and readjust if necessary.

Specifications:

High idle setting **3550 rpm**
Carburetor idle setting **1450 rpm**
Governed idle setting **1600 rpm**

ENGINE - GAS (LIQUID-COOLED) TESTS AND ADJUSTMENTS

Note: For high altitude operation above 4000 feet, use high altitude carburetor kit, to prevent over rich fuel mixture and black exhaust smoke.

Compression Test

Reason:

To determine the condition of pistons, rings, cylinder walls and valves.

Test Equipment:

- JDM59 Compression Gauge

Procedure:

1. Adjust valve clearance to **0.15 mm (0.006 in.)** with engine at top dead center (TDC) compression stroke. Engine must be “cold” (shop temperature, about 60 - 85°F (16 - 30°C)). See “Valve Clearance Adjustment” on page 43 for procedure.

Note: Be sure the battery is fully charged before performing procedure.

2. Run engine until it reaches operating temperature (thermostat opens, and both radiator hoses hot).

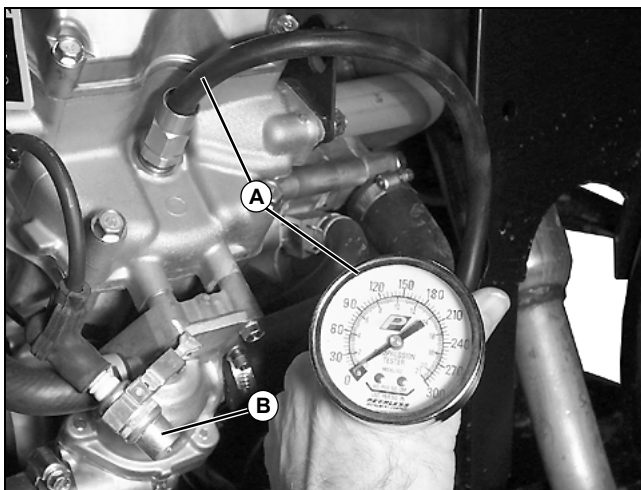

MX14235

3. Stop the engine, remove both spark plugs, and ground leads to block or use a spark tester (B).

4. Attach the compression gauge assembly (A) firmly into one plug hole.

5. Put throttle lever in fast idle (wide open) position. On FD671D engines, choke must be properly adjusted and fully open. Air filter must be clean.

Important: Avoid Damage! DO NOT overheat starting motor during test. Starter duty is 5 seconds on, 10 seconds off. Additionally, if throttle lever is left in slow idle position (air flow into carburetor restricted), compression could read up to 483 kPa (70 psi) below specification.

6. Crank hot engine until highest compression reading is obtained.

7. Record pressure readings for each cylinder.

Specifications:

Minimum Compression 620 kPa (90 psi)

Results:

- If pressure readings are above specification, adjust valves and check fuel and intake air systems. Check exhaust for restriction.
- If pressure readings are below specification, squirt clean engine oil into cylinders and repeat test.
- If pressure increases significantly, check piston rings and cylinder walls for wear or damage.
- If pressure does NOT increase after retest, check for leaking valves, valve seats or cylinder head gaskets.
- Install spark plugs and reconnect ignition coils when finished with testing procedure.

Valve Clearance Adjustment

Reason:

Check and adjust valve clearance for proper engine operation.

Important: Avoid Damage! Perform valve clearance measurement or adjustment when the engine is at room temperature, 16 - 27°C (60 - 80°F). Proper valve clearance is essential for the engine to operate properly. Check valve clearance for each cylinder separately.

Procedure:

1. Remove spark plugs.
2. Remove valve covers.
3. Turn the crankshaft clockwise until piston, visible in the spark plug hole, is at TDC (top dead center) of the compression stroke.

ENGINE - GAS (LIQUID-COOLED) TESTS AND ADJUSTMENTS

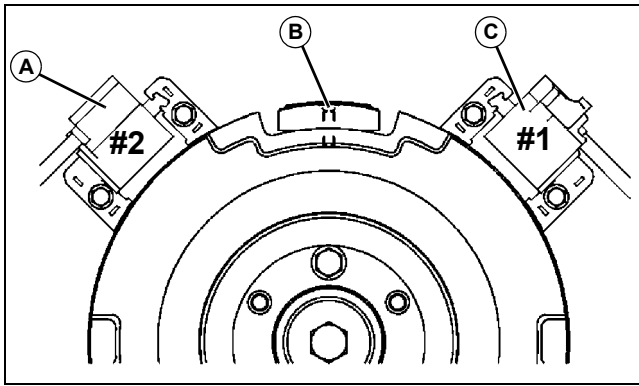

4. Align the flywheel magnet (B) with #1 ignition coil (C) and #2 ignition coil (A).
5. Both intake and exhaust valves will be closed and the rocker arms will be loose. If one rocker arm is tight, the piston is on the exhaust stroke and the crankshaft must be turned another revolution (360 degrees).

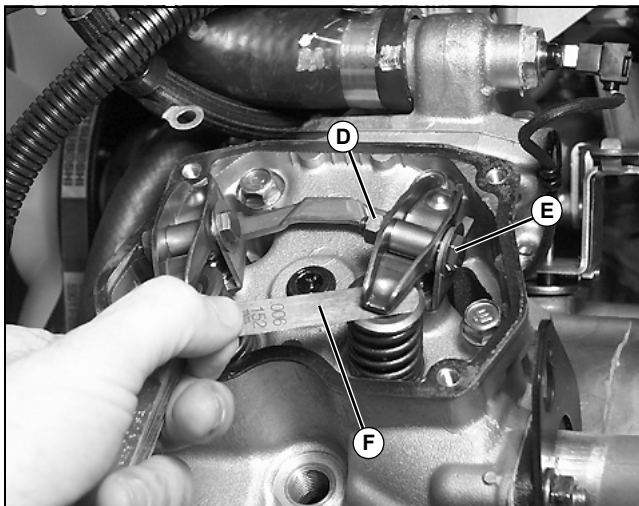

6. Loosen the lock nut (D) and valve clearance adjustment bolt (E).
7. Insert a **0.15 mm (.006 in.)** feeler gauge (F) between rocker arm and valve stem, and turn the adjusting bolt (E) until the thickness gauge begins to bind between the rocker arm and valve stem end.
8. Holding the adjusting bolt, tighten the locknut to **11 N•m (96 lb-in.)**. Repeat for either exhaust or intake valve.
9. Repeat procedure for other cylinder.

Specifications:

Valve Clearance

(at 16 - 27°C (60 - 80°F))..... **0.15 mm (0.006 in.)**

Nut Torque..... **11 N•m (96 lb-in.)**

Spark Plug Torque **25 N•m (221 lb-in.)**

Crankcase Vacuum Test

Reason:

To measure the amount of crankcase vacuum, to ensure the crankcase is not pressurized. A pressurized crankcase will force oil to leak past the seals.

Equipment:

- JTO5697 U-Tube Manometer Test Kit; or,
- JT03503 Crankcase Vacuum Test Kit

Procedure 1:

Important: Avoid Damage! Test must be run with the engine at normal operating temperature, if not, test will be inaccurate. DO NOT use more than 3 feet of manometer tubing. If a longer hose is used the readings will be inaccurate.

1. Park machine on level surface.
2. Raise engine hood and remove dipstick. Check dipstick/oil fill cap and O-ring for cracks or damage, replace as necessary.
3. Install appropriate size rubber plug in dipstick tube.
4. Insert barbed fitting in rubber plug so that clear line to fitting (A) can be connected at a later step.

Important: Avoid Damage! DO NOT make connection between U-Tube Manometer clear line and engine crankcase BEFORE engine is running or fluid in manometer could be drawn into crankcase.

5. Attach manometer magnets to a solid metal surface.

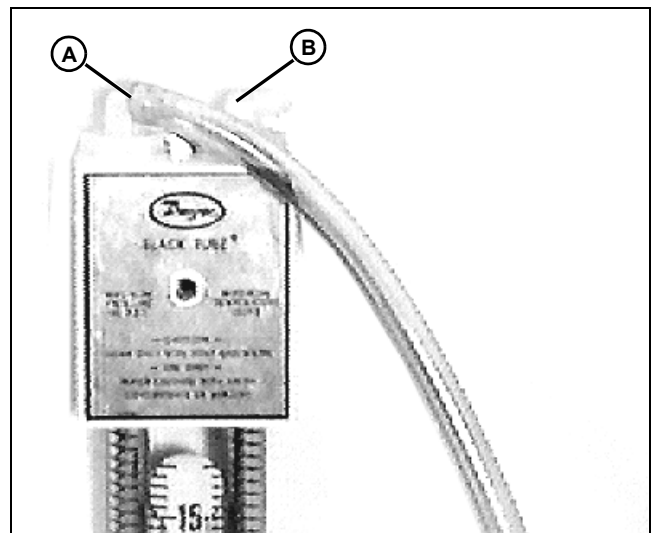

6. Open top valves (A) and (B) one turn.

ENGINE - GAS (LIQUID-COOLED) TESTS AND ADJUSTMENTS

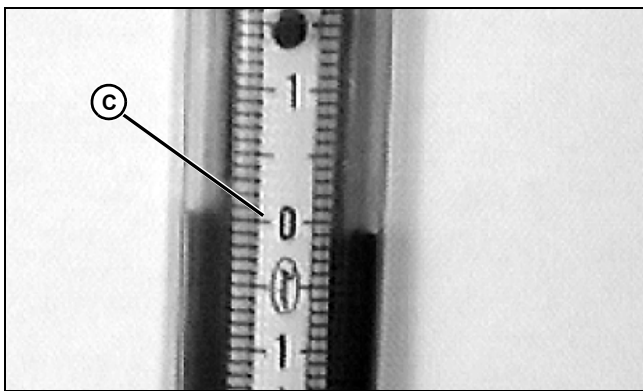

M88762

7. Zero the manometer by sliding the ruled scale up or down so "0" (C) is located where water level on both sides is even.

8. Hold finger over rubber plug hole to keep oil from spraying out. Start engine, move the throttle lever to fast idle (3400 rpm) and allow engine to reach operating temperature.

9. Quickly attach clear line from manometer to rubber plug in dipstick opening.

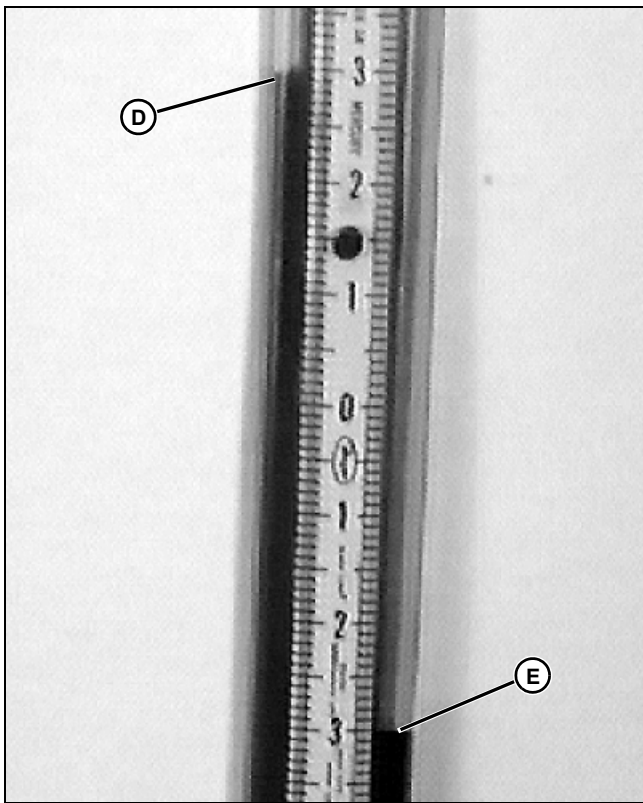

M88764

Picture Note: Example: 3 + 3 = 6 in. of vacuum

10. Record vacuum reading. Gauge should show a minimum vacuum of 10.2 cm (4 in.) of water movement. The reading is obtained by adding (D) and (E) water movement from "0" position.

Important: Avoid Damage! Repeat test at least three times for accuracy. To repeat test, remove the manometer tube from top of manometer at "A". DO NOT remove manometer tube from engine. Perform step #7 then reattach manometer tube to side "A". Continue with step #10.

11. Remove line from manometer before stopping engine. Then remove dipstick hose connection and install dipstick.

Procedure 2:

1. Park machine on level surface.
2. Raise engine hood and remove dipstick. Check dipstick/oil fill cap and O-ring for cracks or damage, replace as necessary.
3. Install appropriate size rubber plug in dipstick tube.
4. Insert barbed fitting in rubber plug so that clear line to fitting can be connected at a later step.

Important: Avoid Damage! DO NOT make connection between test gauge and rubber plug BEFORE engine is running at FAST idle or gauge damage may result.

After test reading is made, DO disconnect test gauge WHILE engine is running at FAST idle to prevent damage to gauge.

5. Hold finger over rubber plug hole to keep oil from spraying out. Start engine, move the throttle lever to fast idle and allow engine to reach operating temperature.
6. Connect gauge, clear line, and barbed fitting to rubber plug.
7. Record crankcase vacuum reading. Gauge should show a minimum vacuum of 10.2 cm (4 in.) of water movement.
8. Disconnect barbed fitting, clear line, and gauge from rubber plug while engine is running at FAST idle. Hold finger over rubber plug hole to keep oil from spraying out.
9. Move throttle to SLOW idle and turn engine OFF.
10. Remove rubber plug and install dipstick.

Specification:

Minimum Crankcase Vacuum at 3400 rpm
 10.2 cm (4 in. water)

Results:

If crankcase vacuum does not meet specification, check the following:

Note: A new engine may have low vacuum readings due to the fact that the rings are not seated.

- Seals and gaskets for leakage

ENGINE - GAS (LIQUID-COOLED) TESTS AND ADJUSTMENTS

- Rocker arm cover O-ring for leakage
- Rings, piston, and cylinder bore for wear or damage

Engine Oil Pressure Test

Reason:

To determine condition of lubrication system.

Equipment:

- JT03344 Pressure Gauge Assembly
- JT03349 Connector
- JT03017 Hose Assembly



Caution: Avoid Injury! Engine components are HOT. Be careful not to touch, especially the exhaust pipe or muffler while making adjustments. Wear protective eye glasses and clothing.

Procedure - Preliminary Check:

1. Park machine on level surface.
2. Turn key switch OFF. Allow engine to cool.
3. Move forward/reverse pedals to NEUTRAL position.
4. Engage parking brake and raise hood.
5. Check engine oil level, bring oil level to full mark.

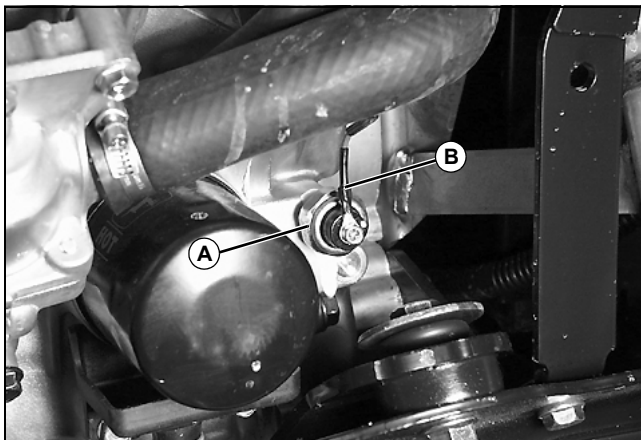

MX14241

6. Disconnect oil pressure switch wiring lead (B).
7. Remove oil pressure switch (A).

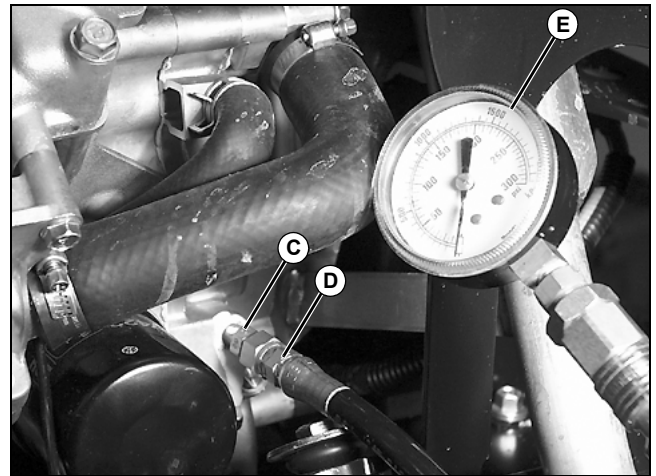

MX14242

8. Install JT03349 Connector (C).
9. Install JT03017 Hose Assembly (D) and JT03344 pressure gauge assembly (E).
10. Monitor oil pressure while cranking engine. If no oil pressure is present discontinue cranking engine. Determine and correct cause before running engine.

Important: Avoid Damage! If pressure reading is below 69 kPa (10 psi), STOP ENGINE IMMEDIATELY and determine cause.

Procedure- Engine Running:

1. Start and Run engine at medium idle for five minutes to heat engine oil to normal operating temperature.
2. Run engine at fast idle (3350 rpm) and check oil pressure. Gauge should read a minimum oil pressure of **276 kPa (40 psi)**.

Results:

- If oil pressure reading is BELOW specifications, inspect or replace the following:
 - Oil pressure relief valve spring worn or broken
 - Oil pressure relief valve stuck or broken.
 - Oil pump worn or damaged
 - Oil pump suction screen or oil passages plugged
 - Connecting rod and main bearing journals excessively worn.
 - Connecting rod and main bearing journals excessively worn.
 - Oil filter plugged.

Specifications:

Minimum Oil Pressure 276 kPa (40 psi)
Oil Pressure Switch Torque 15 N•m (132 lb-in.)

ENGINE - GAS (LIQUID-COOLED) TESTS AND ADJUSTMENTS

Fuel Pump Flow Test for Carburetor (FD671D)

Reason:

To determine proper fuel flow from transfer pump.

Test Equipment:

- Graduated container

Procedure:

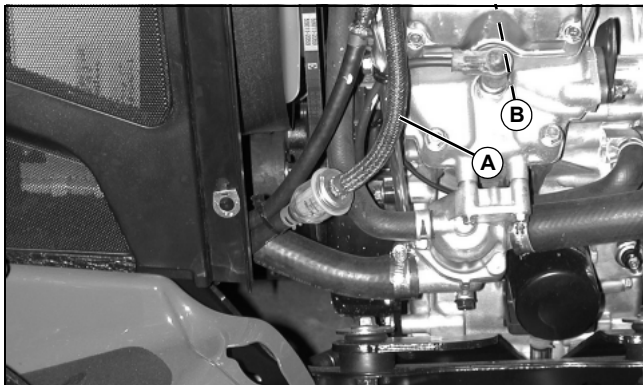

1. Disconnect fuel supply hose (A) from carburetor (B) and put end in a graduated cylinder.
2. Turn key switch on for 10 seconds. DO NOT start engine.

Results:

- If fuel flow is **below 300 mL (10 oz)/10 seconds**, check fuel pump filter, in-line filter, hoses, and fuel shutoff valve for debris or restrictions. Replace filters; then test again.
- If fuel flow is still **below 300 mL (10 oz)/10 seconds**, replace fuel pump.

Fuel Pump Pressure Test for Carburetor (FD671D)

Reason:

To check condition of fuel pump and determine fuel pressure.

Test Equipment:

- JDG356 Fuel Pump Pressure Test Kit

Procedure:

1. Engage parking brake.

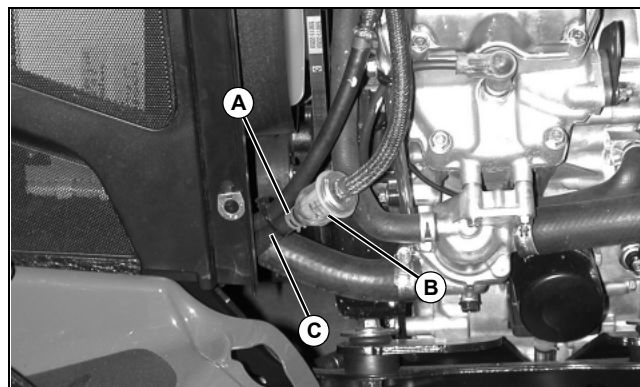

2. Loosen clamp (A), and disconnect fuel supply hose (C) from fuel filter (B).
3. Connect fuel pump pressure test kit to end of supply hose (C).
4. Turn key switch on. DO NOT start engine. Observe pressure reading.

Results:

- If fuel pressure is below **10 kPa (1.5 psi)**, check fuel pump filter, in-line filter, hoses, and fuel shutoff valve for debris or restrictions. Replace filters; then test again.
- If pressure is still below **10 kPa (1.5 psi)**, replace fuel pump.



Suggest:

If the above button click is invalid.

Please download this document

first, and then click the above link

to download the complete manual.

Thank you so much for reading

ENGINE - GAS (LIQUID-COOLED) TESTS AND ADJUSTMENTS

Fuel Pump Pressure Test For Fuel Injection (FD750D)

Reason:

To check condition of fuel pump and fuel pressure regulator which determines fuel pressure.

Test Equipment:

- JT07032 400 kPa (60 psi) Pressure Gauge
- JDG41 1/4 M NPT X 1/8 ID Barbed Fitting
- Fuel Hose and Hose Clamps

Procedure:

1. Engage park brake. Put PTO in OFF position.

Note: Be sure the battery is fully charged.

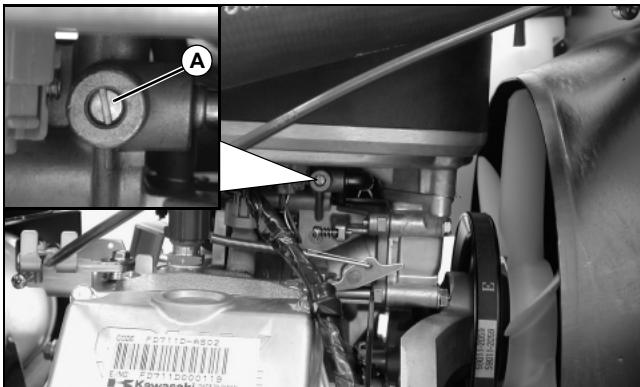

MX15401/MX15402

Picture Note: Left side of engine shown.

2. Loosen the fuel pressure relief screw (A) to relieve the high pressure in the return fuel hose; Do Not close it at this time, leave open.



Caution: Avoid Injury! Be prepared for spilling fuel. Wipe up any fuel immediately. DO NOT try to start engine with the fuel hoses disconnected.

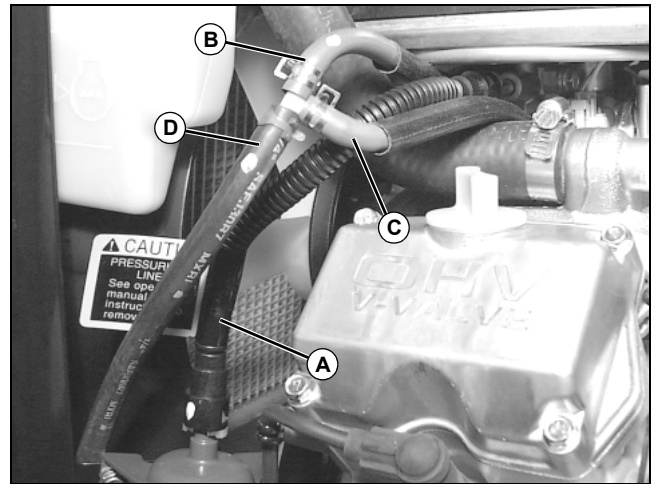

MX31772

- A- Fuel Line from Pump/Filter
- B- From Relief Screw on Throttle Body
- C- Excess Pressure Return from Pressure Regulator
- D- Main Return Line to Fuel Tank

3. Disconnect the fuel line (B) from the tee fitting.
4. Cap the tee fitting open port with a short piece of fuel line and fuel line cap.
5. Install the pressure gauge into the fuel relief line (B).
6. Tighten the hose clamp in the correct position.

Note: The fuel pump will run for two seconds and then shut off.

7. Turn the key to the RUN position and read fuel pressure.
8. Fuel pressure should be **172 - 186 kPa (25 - 27 psi)**.
 - If fuel pressure is higher than specified, check fuel return hose for sharp bends, kinking or clogging or; vacuum hose for air leaks.
 - If fuel pressure is much lower than specified, inspect for fuel line leakage or clogs in fuel filter or fuel pump.If the inspection turns out good, replace entire pressure regulator or fuel pump. See "Fuel Pressure Regulator Removal and Installation (FD750D)" on page 64 in this section, or "Fuel Pump/Fuel Gauge Sensor Removal and Installation" on page 461 in the Miscellaneous section.
9. Remove pressure gauge.
10. Connect the fuel relief hose to the tee fitting and clamp it.
11. Tighten the fuel pressure relief screw (A).

<https://www.ebooklibonline.com>

Hello dear friend!

Thank you very much for reading.

Enter the link into your browser.

The full manual is available for immediate download.

<https://www.ebooklibonline.com>