

JOHN DEERE
WORLDWIDE COMMERCIAL & CONSUMER
EQUIPMENT DIVISION

Garden Tractors
X465, X475, X485, X575 and X585

TM2023 JUNE 2004

TECHNICAL MANUAL



JOHN DEERE

North American Version
Litho in U.S.A.

INTRODUCTION

Manual Description

This technical manual is written for an experienced technician and contains sections that are specifically for this product. It is a part of a total product support program.

The manual is organized so that all the information on a particular system is kept together. The order of grouping is as follows:

- Table of Contents
- Specifications and Information
- Identification Numbers
- Tools and Materials
- Component Location
- Schematics and Harnesses
- Theory of Operation
- Operation and Diagnostics
- Diagnostics
- Tests and Adjustments
- Repair
- Other

NOTE: Depending on the particular section or system being covered, not all of the above groups may be used.

The bleed tabs for the pages of each section will align with the sections listed on this page. Page numbering is consecutive from the beginning of the Safety section through the last section.

We appreciate your input on this manual. If you find any errors or want to comment on the layout of the manual please contact us.

Safety

Specifications and Information

Engine - Gas (Air-Cooled)

Engine - Gas (Liquid-Cooled)

Electrical

Power Train - Hydrostatic

Hydraulics

Steering

Brakes

Attachments

Miscellaneous

All information, illustrations and specifications in this manual are based on the latest information at the time of publication. The right is reserved to make changes at any time without notice.

COPYRIGHT© 2004
Deere & Co.
John Deere Worldwide Commercial and
Consumer Equipment Division
All rights reserved
Previous Editions
COPYRIGHT© 2002; 2003

<https://www.ebooklibonline.com>

Hello dear friend!

Thank you very much for reading.

Enter the link into your browser.

The full manual is available for immediate download.

<https://www.ebooklibonline.com>

SAFETY

Recognize Safety Information



MIF

This is the safety-alert symbol. When you see this symbol on your machine or in this manual, be alert to the potential for personal injury.

Follow recommended precautions and safe servicing practices.

Understand Signal Words

A signal word - DANGER, WARNING, or CAUTION - is used with the safety-alert symbol. DANGER identifies the most serious hazards.

DANGER or WARNING safety signs are located near specific hazards. General precautions are listed on CAUTION safety signs. CAUTION also calls attention to safety messages in this manual.

Replace Safety Signs

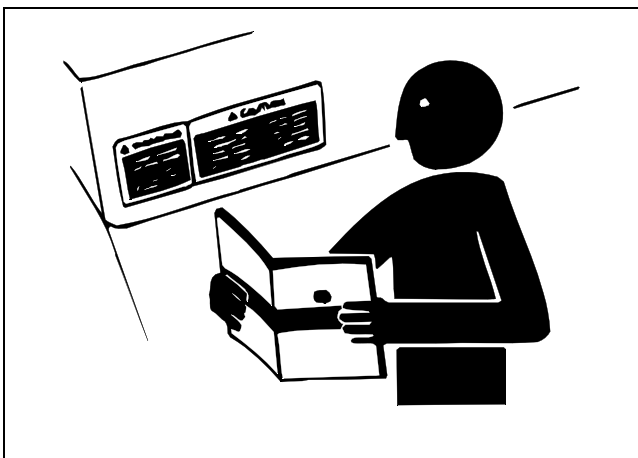

MIF

Replace missing or damaged safety signs. See the machine operator's manual for correct safety sign placement.

Handle Fluids Safely - Avoid Fires

Be Prepared For Emergencies

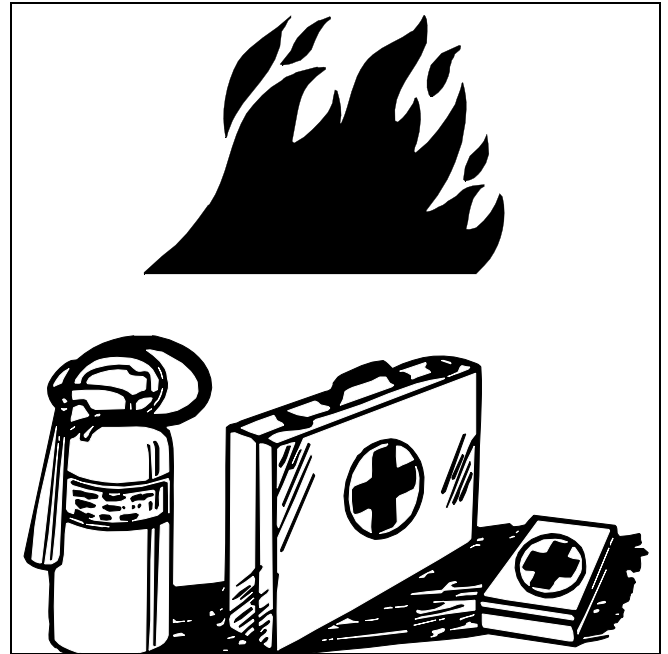

MIF

- When you work around fuel, do not smoke or work near heaters or other fire hazards.
- Store flammable fluids away from fire hazards. Do not incinerate or puncture pressurized containers.
- Make sure machine is clean of trash, grease, and debris.
- Do not store oily rags; they can ignite and burn spontaneously.
- Be prepared if a fire starts.
- Keep a first aid kit and fire extinguisher handy.
- Keep emergency numbers for doctors, ambulance service, hospital, and fire department near your telephone.

Use Care In Handling And Servicing Batteries

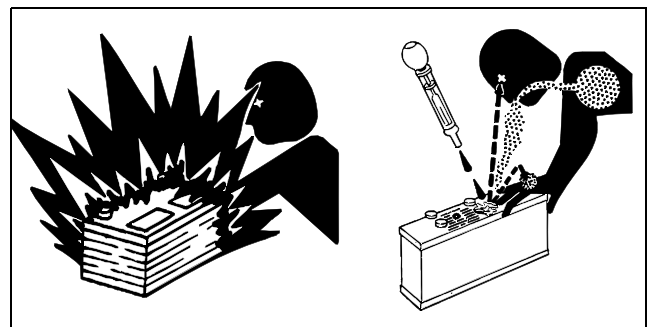

MIF

SAFETY

Prevent Battery Explosions

- Keep sparks, lighted matches, and open flame away from the top of battery. Battery gas can explode.
- Never check battery charge by placing a metal object across the posts. Use a volt-meter or hydrometer.
- Do not charge a frozen battery; it may explode. Warm battery to 16°C (60°F).

Prevent Acid Burns

- Sulfuric acid in battery electrolyte is poisonous. It is strong enough to burn skin, eat holes in clothing, and cause blindness if splashed into eyes.

Avoid acid burns by:

1. Filling batteries in a well-ventilated area.
2. Wearing eye protection and rubber gloves.
3. Avoiding breathing fumes when electrolyte is added.
4. Avoiding spilling or dripping electrolyte.
5. Use proper jump start procedure.

If you spill acid on yourself:

1. Flush your skin with water.
2. Apply baking soda or lime to help neutralize the acid.
3. Flush your eyes with water for 10 - 15 minutes.
4. Get medical attention immediately.

If acid is swallowed:

1. Drink large amounts of water or milk.
2. Then drink milk of magnesia, beaten eggs, or vegetable oil.
3. Get medical attention immediately.

Wear Protective Clothing

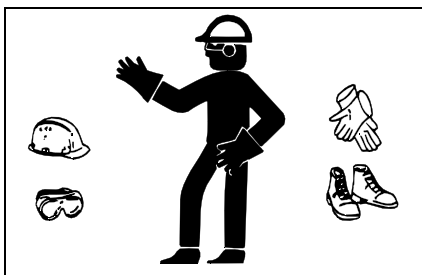

MIF

Wear close fitting clothing and safety equipment appropriate to the job.

Prolonged exposure to loud noise can cause impairment or loss of hearing. Wear a suitable hearing protective device

such as earmuffs or earplugs to protect against objectionable or uncomfortable loud noises.

Operating equipment safely requires the full attention of the operator. Do not wear radio or music headphones while operating machine.

Use Care Around High-pressure Fluid Lines

Avoid High-Pressure Fluids



MIF

Escaping fluid under pressure can penetrate the skin causing serious injury.

Avoid injury from escaping fluid under pressure by stopping the engine and relieving pressure in the system before disconnecting or connecting hydraulic or other lines. Tighten all connections before applying pressure.

Search for leaks with a piece of cardboard. Protect hands and body from high pressure fluids.

If an accident occurs, see a doctor immediately. Any fluid injected into the skin must be surgically removed within a few hours or gangrene may result. Doctors unfamiliar with this type of injury should reference a knowledgeable medical source. Such information is available from Deere & Company Medical Department in Moline, Illinois, U.S.A.

Avoid Heating Near Pressurized Fluid Lines



MIF

Flammable spray can be generated by heating near pressurized fluid lines, resulting in severe burns to yourself and bystanders. Do not heat by welding, soldering, or using a torch near pressurized fluid lines or other flammable materials. Pressurized lines can be accidentally cut when heat goes beyond the immediate flame area.

SAFETY

Service Machines Safely

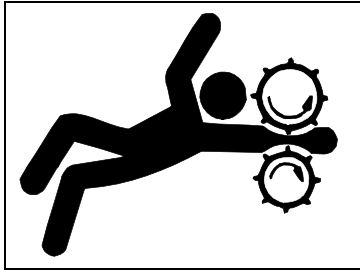

MIF

Tie long hair behind your head. Do not wear a necktie, scarf, loose clothing, or necklace when you work near machine tools or moving parts. If these items were to get caught, severe injury could result.

Remove rings and other jewelry to prevent electrical shorts and entanglement in moving parts.

Use Proper Tools

Use tools appropriate to the work. Makeshift tools and procedures can create safety hazards. Use power tools only to loosen threaded parts and fasteners. For loosening and tightening hardware, use the correct size tools. **DO NOT** use U.S. measurement tools on metric fasteners. Avoid bodily injury caused by slipping wrenches. Use only service parts meeting John Deere specifications.

Park Machine Safely

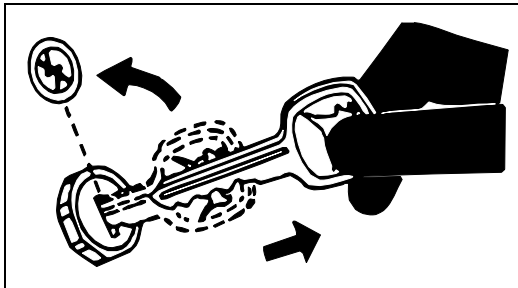

MIF

Before working on the machine:

1. Lower all equipment to the ground.
2. Stop the engine and remove the key.
3. Disconnect the battery ground strap.
4. Hang a "DO NOT OPERATE" tag in operator station.

Support Machine Properly and Use Proper Lifting Equipment

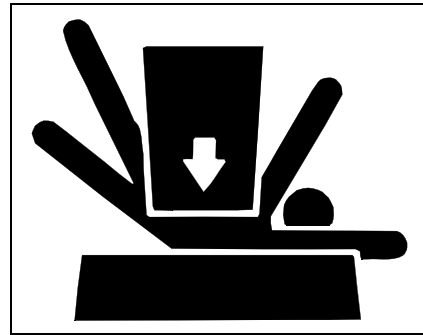

MIF

If you must work on a lifted machine or attachment, securely support the machine or attachment.

Do not support the machine on cinder blocks, hollow tiles, or props that may crumble under continuous load. Do not work under a machine that is supported solely by a jack. Follow recommended procedures in this manual.

Lifting heavy components incorrectly can cause severe injury or machine damage. Follow recommended procedure for removal and installation of components in the manual.

Work In Clean Area

Before starting a job:

1. Clean work area and machine.
2. Make sure you have all necessary tools to do your job.
3. Have the right parts on hand.
4. Read all instructions thoroughly; do not attempt shortcuts.

Using High Pressure Washers

Directing pressurized water at electronic/electrical components or connectors, bearings, hydraulic seals, fuel injection pumps or other sensitive parts and components may cause product malfunctions. Reduce pressure and spray at a 45 to 90 degree angle.

Illuminate Work Area Safely

Illuminate your work area adequately but safely. Use a portable safety light for working inside or under the machine. Make sure the bulb is enclosed by a wire cage. The hot filament of an accidentally broken bulb can ignite spilled fuel or oil.

SAFETY

Work In Ventilated Area

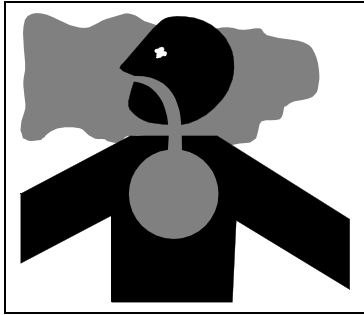

MIF

Engine exhaust fumes can cause sickness or death. If it is necessary to run an engine in an enclosed area, remove the exhaust fumes from the area with an exhaust pipe extension.

If you do not have an exhaust pipe extension, open the doors and get outside air into the area.

Warning: California Proposition 65 Warning

Gasoline engine exhaust from this product contains chemicals known to the State of California to cause cancer, birth defects, or other reproductive harm.

Diesel engine exhaust and some of its constituents are known to the State of California to cause cancer, birth defects, and other reproductive harm.

Remove Paint Before Welding or Heating

Avoid potentially toxic fumes and dust. Hazardous fumes can be generated when paint is heated by welding, soldering, or using a torch. Do all work outside or in a well ventilated area. Dispose of paint and solvent properly. Remove paint before welding or heating: If you sand or grind paint, avoid breathing the dust. Wear an approved respirator. If you use solvent or paint stripper, remove stripper with soap and water before welding. Remove solvent or paint stripper containers and other flammable material from area. Allow fumes to disperse at least 15 minutes before welding or heating.

Avoid Harmful Asbestos Dust

Avoid breathing dust that may be generated when handling components containing asbestos fibers. Inhaled asbestos fibers may cause lung cancer.

Components in products that may contain asbestos fibers are brake pads, brake band and lining assemblies, clutch plates, and some gaskets. The asbestos used in these components is usually found in a resin or sealed in some way. Normal handling is not hazardous as long as airborne dust containing asbestos is not generated.

Avoid creating dust. Never use compressed air for cleaning. Avoid brushing or grinding material containing asbestos. When servicing, wear an approved respirator. A special vacuum cleaner is recommended to clean asbestos. If not available, apply a mist of oil or water on the material containing asbestos. Keep bystanders away from the area.

Service Tires Safely

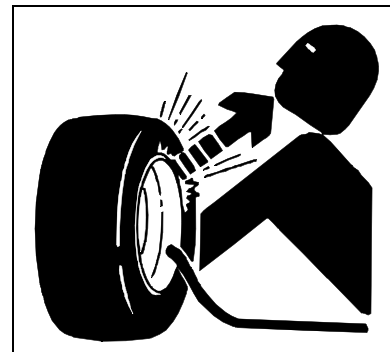

MIF

Explosive separation of a tire and rim parts can cause serious injury or death.

Do not attempt to mount a tire unless you have the proper equipment and experience to perform the job.

Always maintain the correct tire pressure. Do not inflate the tires above the recommended pressure. Never weld or heat a wheel and tire assembly. The heat can cause an increase in air pressure resulting in a tire explosion. Welding can structurally weaken or deform the wheel.

When inflating tires, use a clip-on chuck and extension hose long enough to allow you to stand to one side and NOT in front of or over the tire assembly. Use a safety cage if available.

Check wheels for low pressure, cuts, bubbles, damaged rims or missing lug bolts and nuts.

SAFETY

Avoid Injury From Rotating Blades, Augers And PTO Shafts

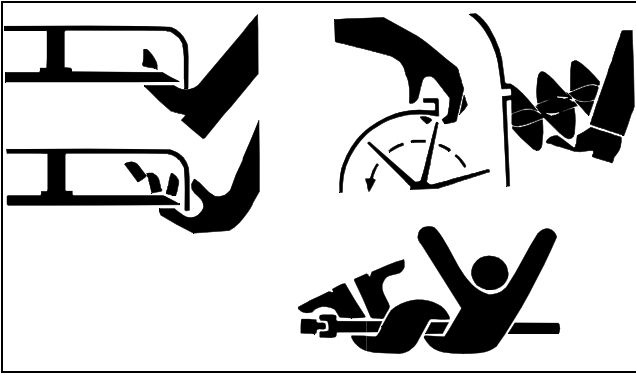

MIF

Keep hands and feet away while machine is running. Shut off power to service, lubricate or remove mower blades, augers or PTO shafts.

Service Cooling System Safely

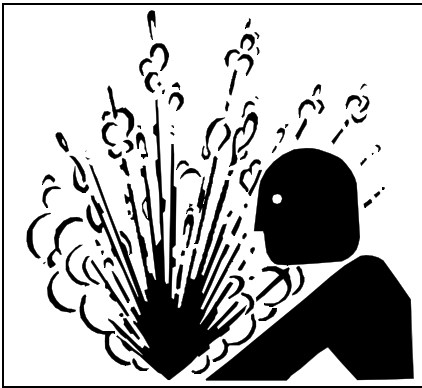

MIF

Explosive release of fluids from pressurized cooling system can cause serious burns.

Shut off machine. Only remove filler cap when cool enough to touch with bare hands. Slowly loosen cap to first stop to relieve pressure before removing completely.

Handle Chemical Products Safely

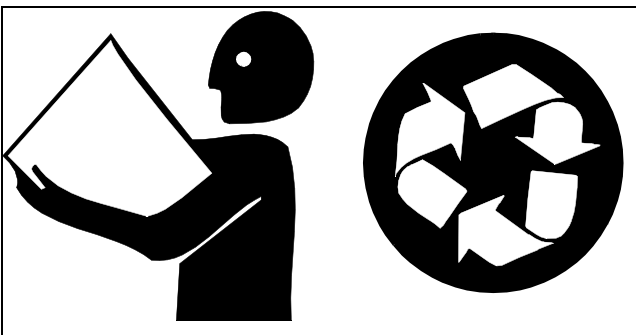

MIF

Direct exposure to hazardous chemicals can cause serious injury. Potentially hazardous chemicals used with John Deere equipment include such items as lubricants, coolants, paints, and adhesives.

A Material Safety Data Sheet (MSDS) provides specific details on chemical products: physical and health hazards, safety procedures, and emergency response techniques. Check the MSDS before you start any job using a hazardous chemical. That way you will know exactly what the risks are and how to do the job safely. Then follow procedures and recommended equipment.

Dispose of Waste Properly

Improperly disposing of waste can threaten the environment and ecology. Potentially harmful waste used with John Deere equipment include such items as oil, fuel, coolant, brake fluid, filters, and batteries. Use leakproof containers when draining fluids. Do not use food or beverage containers that may mislead someone into drinking from them. Do not pour waste onto the ground, down a drain, or into any water source. Inquire on the proper way to recycle or dispose of waste from your local environmental or recycling center, or from your John Deere dealer.

Live With Safety



MIF

Before returning machine to customer, make sure machine is functioning properly, especially the safety systems. Install all guards and shields.

SAFETY



SPECIFICATIONS & INFORMATION TABLE OF CONTENTS

Table of Contents

Fastener Torques	9
Metric Fastener Torque Values	9
Inch Fastener Torque Values	10
O-Ring Seal Service Recommendations	11
Face Seal Fittings With Inch Stud Ends	
Torque	11
Face Seal Fittings With Metric Stud Ends	
Torque	12
O-Ring Face Seal Fittings	13
O-Ring Boss Fittings	13
Straight Fitting or Special Nut Torques	14
Metric Fastener Torque Value - Grade 7	
(Special)	14
General Information	14
Gasoline	14
Gasoline Storage.....	15
4 - Cycle Gasoline Engine Oil	15
Break-In Engine Oil - 4-Cycle Gasoline.....	16
Hydrostatic Transmission and Hydraulic Oil.....	16
Gear Case Oil.....	17
Gear Transmission Grease	18
Alternative Lubricants.....	18
Synthetic Lubricants	18
Lubricant Storage	18
Mixing of Lubricants	18
Oil Filters	18
Coolant Specifications	19
Gasoline Engine Coolant.....	19
Gasoline Engine Coolant Drain Interval	19
Serial Number Locations	20
Product Serial Number	20
Gasoline Engine Serial Number Location	20

























SPECIFICATIONS & INFORMATION TABLE OF CONTENTS



SPECIFICATIONS & INFORMATION FASTENER TORQUES

Fastener Torques

Metric Fastener Torque Values

Property Class and Head Markings	4.8   	8.8 9.8    	10.9  	12.9    
Property Class and Nut Markings	5   	10   	10   	12   

MIF

SIZE	Class 4.8				Class 8.8 or 9.8				Class 10.9				Class 12.9			
	Lubricated a		Dry a		Lubricated a		Dry a		Lubricated a		Dry a		Lubricated a		Dry a	
	N•m	lb-ft	N•m	lb-ft	N•m	lb-ft	N•m	lb-ft	N•m	lb-ft	N•m	lb-ft	N•m	lb-ft	N•m	lb-ft
M6	4.8	3.5	6	4.5	9	6.5	11	8.5	13	9.5	17	12	15	11.5	19	14.5
M8	12	8.5	15	11	22	16	28	20	32	24	40	30	37	28	47	35
M10	23	17	29	21	43	32	55	40	63	47	80	60	75	55	95	70
M12	40	29	50	37	75	55	95	70	110	80	140	105	130	95	165	120
M14	63	47	80	60	120	88	150	110	175	130	225	165	205	150	260	109
M16	100	73	125	92	190	140	240	175	275	200	350	225	320	240	400	300
M18	135	100	175	125	260	195	330	250	375	275	475	350	440	325	560	410
M20	190	140	240	180	375	275	475	350	530	400	675	500	625	460	800	580
M22	260	190	330	250	510	375	650	475	725	540	925	675	850	625	1075	800
M24	330	250	425	310	650	475	825	600	925	675	1150	850	1075	800	1350	1000
M27	490	360	625	450	950	700	1200	875	1350	1000	1700	1250	1600	1150	2000	1500
M30	675	490	850	625	1300	950	1650	1200	1850	1350	2300	1700	2150	1600	2700	2000
M33	900	675	1150	850	1750	1300	2200	1650	2500	1850	3150	2350	2900	2150	3700	2750
M36	1150	850	1450	1075	2250	1650	2850	2100	3200	2350	4050	3000	3750	2750	4750	3500

DO NOT use these hand torque values if a different torque value or tightening procedure is given for a specific application. Torque values listed are for general use only and include a $\pm 10\%$ variance factor. Check tightness of fasteners periodically. DO NOT use air powered wrenches.

Shear bolts are designed to fail under predetermined loads. Always replace shear bolts with identical grade.

Fasteners should be replaced with the same grade. Make sure fastener threads are clean and that you properly start thread engagement. This will prevent them from failing when tightening.

When bolt and nut combination fasteners are used, torque values should be applied to the NUT instead of the bolt head.









Tighten toothed or serrated-type lock nuts to the full torque value.

a "Lubricated" means coated with a lubricant such as engine oil, or fasteners with phosphate and oil coatings. "Dry" means plain or zinc plated (yellow dichromate - Specification JDS117) without any lubrication.

Reference: JDS - G200.

SPECIFICATIONS & INFORMATION FASTENER TORQUES

Inch Fastener Torque Values

SAE Grade and Head Markings	1 or 2 ^b No Marks 	5 5.1 5.2 	8 8.2 
SAE Grade and Nut Markings	2 No Marks 	5  	8  

MIF

SIZE	Grade 1		Grade 2b		Grade 5, 5.1 or 5.2				Grade 8 or 8.2							
	Lubricated a		Dry a		Lubricated a		Dry a		Lubricated a		Dry a		Lubricated a		Dry a	
	N•m	lb-ft	N•m	lb-ft	N•m	lb-ft	N•m	lb-ft	N•m	lb-ft	N•m	lb-ft	N•m	lb-ft	N•m	lb-ft
1/4	3.7	2.8	4.7	3.5	6	4.5	7.5	5.5	9.5	7	12	9	13.5	10	17	12.5
5/16	7.7	5.5	10	7	12	9	15	11	20	15	25	18	28	21	35	26
3/8	14	10	17	13	22	16	27	20	35	26	44	33	50	36	63	46
7/16	22	16	28	20	35	26	44	32	55	41	70	52	80	58	100	75
1/2	33	25	42	31	53	39	67	50	85	63	110	80	120	90	150	115
9/16	48	36	60	45	75	56	95	70	125	90	155	115	175	130	225	160
5/8	67	50	85	62	105	78	135	100	170	125	215	160	215	160	300	225
3/4	120	87	150	110	190	140	240	175	300	225	375	280	425	310	550	400
7/8	190	140	240	175	190	140	240	175	490	360	625	450	700	500	875	650
1	290	210	360	270	290	210	360	270	725	540	925	675	1050	750	1300	975
1-1/8	470	300	510	375	470	300	510	375	900	675	1150	850	1450	1075	1850	1350
1-1/4	570	425	725	530	570	425	725	530	1300	950	1650	1200	2050	1500	2600	1950
1-3/8	750	550	950	700	750	550	950	700	1700	1250	2150	1550	2700	2000	3400	2550
1-1/2	1000	725	1250	925	990	725	1250	930	2250	1650	2850	2100	3600	2650	4550	3350

DO NOT use these hand torque values if a different torque value or tightening procedure is given for a specific application. Torque values listed are for general use only and include a ±10% variance factor. Check tightness of fasteners periodically. DO NOT use air powered wrenches.

Shear bolts are designed to fail under predetermined loads. Always replace shear bolts with identical grade.

Fasteners should be replaced with the same grade. Make sure fastener threads are clean and that you properly start thread engagement. This will prevent them from failing when tightening.

When bolt and nut combination fasteners are used, torque values should be applied to the NUT instead of the bolt

head.

Tighten toothed or serrated-type lock nuts to the full torque value.

a "Lubricated" means coated with a lubricant such as engine oil, or fasteners with phosphate and oil coatings. "Dry" means plain or zinc plated (yellow dichromate - Specification JDS117) without any lubrication.

b "Grade 2" applies for hex cap screws (Not Hex Bolts) up to 152 mm (6 in.) long. "Grade 1" applies for hex cap screws over 152 mm (6 in.) long, and for all other types of bolts and screws of any length.

Reference: JDS - G200

SPECIFICATIONS & INFORMATION O-RING SEAL SERVICE

O-Ring Seal Service Recommendations

Face Seal Fittings With Inch Stud Ends Torque

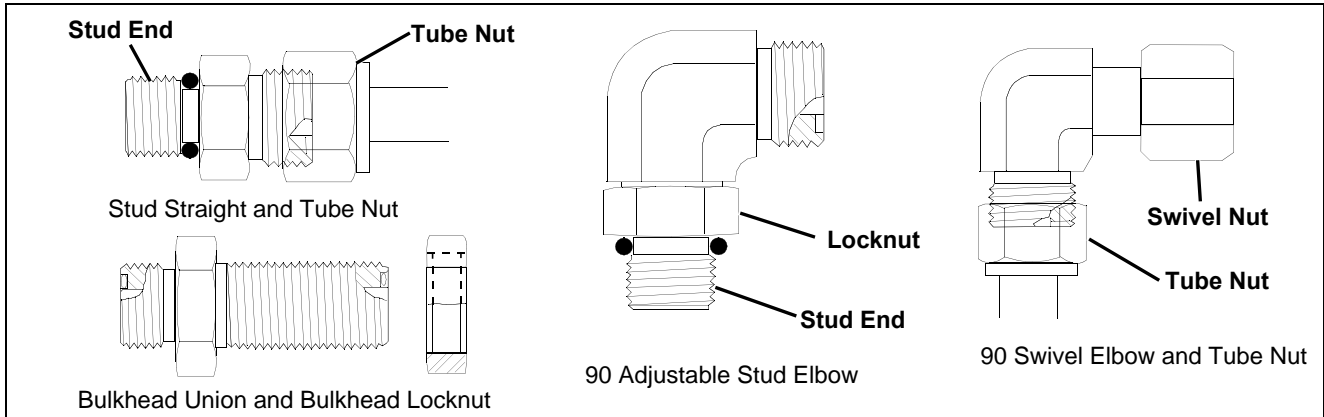

MIF

Nominal Tube OD/Hose ID				Face Seal Tube/Hose End					O-Ring Stud Ends		
Metric Tube OD	Inch Tube OD			Thread Size	Tube Nut/ Swivel Nut Torque		Bulkhead Lock Nut Torque		Thread Size	Straight Fitting or Lock Nut Torque	
	mm	Dash Size	in.		mm	in.	N•m	lb-ft		N•m	lb-ft
5	-3	0.188	4.76						3/8-24	8	6
6	-4	0.250	6.35	9/16-18	16	12	12	9	7/16-20	12	9
8	-5	0.312	7.94						1/2-20	16	12
10	-6	0.375	9.52	11/16-16	24	18	24	18	9/16-18	24	18
12	-8	0.500	12.70	13/16-16	50	37	46	34	3/4-16	46	34
16	-10	0.625	15.88	1-14	69	51	62	46	7/8-14	62	46
19	-12	0.750	19.05	1-3/16-12	102	75	102	75	1-1/16-12	102	75
22	-14	0.875	22.22	1-3/16-12	102	75	102	75	1-3/16-12	122	90
25	-16	1.000	25.40	1-7/16-12	142	105	142	105	1-5/16-12	142	105
32	-20	1.25	31.75	1-11/16-12	190	140	190	140	1-5/8-12	190	140
38	-24	1.50	38.10	2-12	217	160	217	160	1-7/8-12	217	160

NOTE: Torque tolerance is +15%, -20%

SPECIFICATIONS & INFORMATION O-RING SEAL SERVICE

Face Seal Fittings With Metric Stud Ends Torque

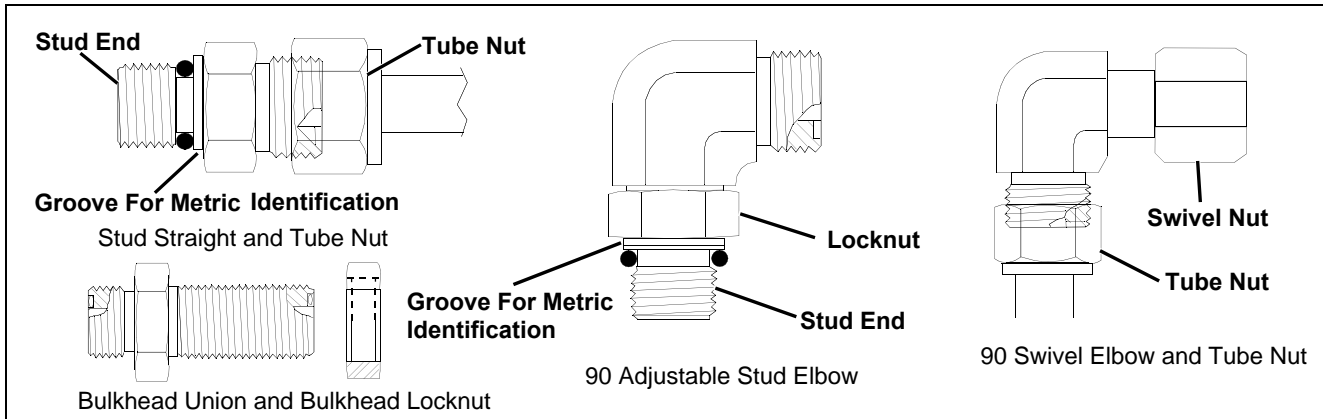

Nominal Tube OD/Hose ID				Face Seal Tube/Hose End						O-Ring Stud Ends, Straight Fitting or Lock Nut					
Metric Tube OD	Inch Tube OD			Thread Size	Hex Size	Tube Nut/ Swivel Nut Torque		Bulkhead Lock Nut Torque		Thread Size	Hex Size	Steel or Gray Iron Torque		Aluminum Torque	
	Dash Size	in.	mm			in.	mm	N•m	lb-ft			N•m	lb-ft	mm	mm
6	-4	0.250	6.35	9/16-18	17	16	12	12	9	M12X1.5	17	21	15.5	9	6.6
8	-5	0.312	7.94												
										M14X1.5	19	33	24	15	11
10	-6	0.375	9.52	11/16-16	22	24	18	24	18	M16X1.5	22	41	30	18	13
12	-8	0.500	12.70	13/16-16	24	50	37	46	34	M18X1.5	24	50	37	21	15
16	-10	0.625	15.88	1-14	30	69	51	62	46	M22X1.5	27	69	51	28	21
	-12	0.750	19.05	1-3/16-12	36	102	75	102	75	M27X2	32	102	75	46	34
22	-14	0.875	22.22	1-3/16-12	36	102	75	102	75	M30X2	36				
25	-16	1.000	25.40	1-7/16-12	41	142	105	142	105	M33X2	41	158	116	71	52
28										M38X2	46	176	130	79	58
32	-20	1.25	31.75	1-11/16-12	50	190	140	190	140	M42X2	50	190	140	85	63
38	-24	1.50	38.10	2-12	60	217	160	217	160	M48X2	55	217	160	98	72

NOTE: Torque tolerance is +15%, -20%

SPECIFICATIONS & INFORMATION O-RING SEAL SERVICE

O-Ring Face Seal Fittings

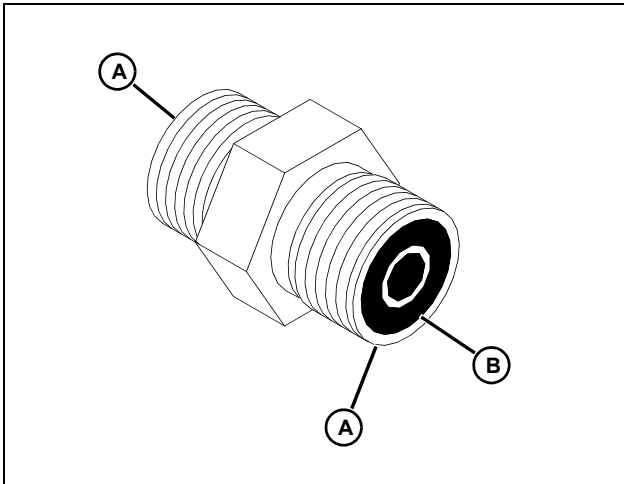

MIF

1. Inspect the fitting sealing surfaces (A). They must be free of dirt or defects.
2. Inspect the O-ring (B). It must be free of damage or defects.
3. Lubricate O-rings and install into groove using petroleum jelly to hold in place during assembly.
4. Index angle fittings and tighten by hand pressing joint together to insure O-ring remains in place.

IMPORTANT: Avoid damage! DO NOT allow hoses to twist when tightening fittings. Use two wrenches to tighten hose connections; one to hold the hose, and the other to tighten the swivel fitting.

5. Tighten fitting or nut to torque value shown on the chart per dash size stamped on the fitting.

O-Ring Boss Fittings

1. Inspect boss O-ring boss seat. It must be free of dirt and defects. If repeated leaks occur, inspect for defects with a magnifying glass. Some raised defects can be removed with a slip stone.

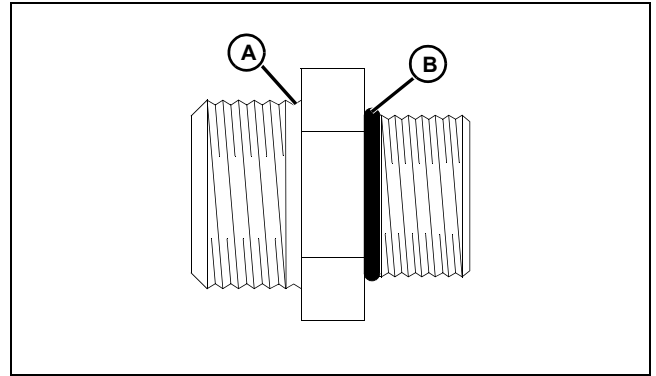

MIF

2. Put hydraulic oil or petroleum jelly on the O-ring (B). Place electrical tape over the threads to protect O-ring from nicks. Slide O-ring over the tape and into the groove (A) of fitting. Remove tape.

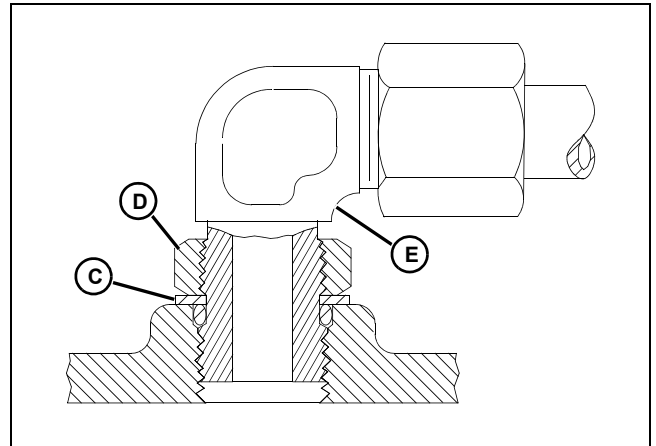

MIF

3. For angle fittings, loosen special nut (D) and push special washer (C) against threads so O-ring can be installed into the groove of fitting.
4. Turn fitting into the boss by hand until special washer or washer face (straight fitting) contacts boss face and O-ring is squeezed into its seat.
5. To position angle fittings (E), turn the fitting counter-clockwise a maximum of one turn.
6. Tighten straight fittings to torque value shown on chart. For angle fittings, tighten the special nut to value shown in the chart while holding body of fitting with a wrench.

SPECIFICATIONS & INFORMATION GENERAL INFORMATION

Straight Fitting or Special Nut Torques

Thread Size	Torque ^a		Number of Flats ^b
	N•m	lb-ft	
3/8-24 UNF	8	6	2
7/16-20 UNF	12	9	2
1/2-20 UNF	16	12	2
9/16-18 UNF	24	18	2
3/4-16 UNF	46	34	2
7/8-14 UNF	62	46	1-1/2
1-1/16-12 UN	102	75	1
1-3/16-12 UN	122	90	1
1-5/16-12 UN	142	105	3/4
1-5/8-12 UN	190	140	3/4
1-7/8-12 UN	217	160	1/2

^aTorque tolerance is \pm 10 percent.

^bTo be used if a torque wrench cannot be used. After tightening fitting by hand, put a mark on nut or boss; then tighten special nut or straight fitting the number of flats shown.

Metric Fastener Torque Value - Grade 7 (Special)

Size	Steel or Gray Iron Torque	Aluminum Torque
	N•m (lb-ft)	N•m (lb-ft)
M6	11 (8)	8 (6)
M8	24 (18)	19 (14)
M10	52 (38)	41 (30)
M12	88 (65)	70 (52)
M14	138 (102)	111 (82)
M16	224 (165)	179 (132)

General Information

Gasoline

4 - Cycle Engines



CAUTION: Avoid Injury! Gasoline is HIGHLY FLAMMABLE, handle it with care. DO NOT refuel machine while: indoors, always fill gas tank outdoors; machine is near an open flame or sparks; engine is running, STOP engine; engine is hot, allow it to cool sufficiently first; smoking. Help prevent fires: fill gas tank to bottom of filler neck only; be sure fill cap is tight after fueling; clean up any gas spills IMMEDIATELY; keep machine clean and in good repair - free of excess grease, oil, debris, and faulty or damaged parts; any storage of machines with gas left in tank should be in an area that is well ventilated to prevent possible igniting of fumes by an open flame or spark, this includes any appliance with a pilot light. To prevent fire or explosion caused by STATIC ELECTRIC DISCHARGE during fueling: •ONLY use a clean, approved POLYETHYLENE PLASTIC fuel container and funnel WITHOUT any metal screen or filter.

To avoid engine damage:

- DO NOT mix oil with gasoline;
- **ONLY use clean, fresh unleaded gasoline with an octane rating (anti-knock index) of 87 or higher;**
- fill gas tank at the end of each day's operation to help prevent condensation from forming inside a partially filled tank;
- keep up with specified service intervals.

Use of alternative oxygenated, gasohol blended, unleaded gasoline is acceptable as long as:

- the ethyl or grain alcohol blends DO NOT exceed 10% by volume or
- methyl tertiary butyl ether (MTBE) blends DO NOT exceed 15% by volume

RFG (reformulated) gasoline is acceptable for all machines designed for use of regular unleaded fuel. Older machines (that were designed for leaded fuel) may see some accelerated valve and seat wear.

SPECIFICATIONS & INFORMATION GENERAL INFORMATION

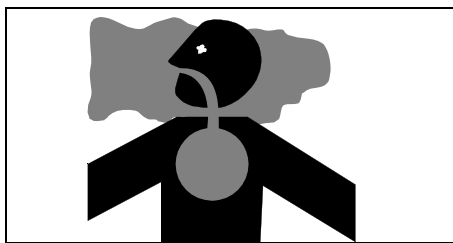

MIF

IMPORTANT: Avoid damage! California Proposition 65 Warning: Gasoline engine exhaust from this product contains chemicals known to the State of California to cause cancer, birth defects, or other reproductive harm.

Gasoline Storage

IMPORTANT: Avoid damage! Keep all dirt, scale, water or other foreign material out of gasoline.

Keep gasoline stored in a safe, protected area. Storage of gasoline in a clean, properly marked ("UNLEADED GASOLINE") POLYETHYLENE PLASTIC container WITHOUT any metal screen or filter is recommended. DO NOT use de-icers to attempt to remove water from gasoline or depend on fuel filters to remove water from gasoline. Use a water separator installed in the storage tank outlet. BE SURE to properly discard unstable or contaminated gasoline. When storing the machine or gasoline, it is recommended that you add **John Deere Gasoline Conditioner and Stabilizer (TY15977)** or an equivalent to the gasoline. BE SURE to follow directions on container and to properly discard empty container.

4 - Cycle Gasoline Engine Oil

Use the appropriate oil viscosity based on the expected air temperature range during the period between recommended oil changes. Operating outside of these recommended oil air temperature ranges may cause premature engine failure.

The following John Deere oils are **PREFERRED**:

- **PLUS - 4® - SAE 10W-40;**
- **TORQ - GARD SUPREME® - SAE 5W-30.**

The following John Deere oils are **also recommended**, based on their specified temperature range:

- **TURF - GARD® - SAE 10W-30;**
- **PLUS - 4® - SAE 10W-30;**
- **TORQ - GARD SUPREME® - SAE 30.**

Other oils may be used if above John Deere oils are not available, provided they meet one of the following specifications:

- SAE 10W-40 - API Service Classifications SG or higher;
- SAE 5W-30 - API Service Classification SG or higher;
- SAE 10W-30 - API Service Classifications SG or higher;
- SAE 30 - API Service Classification SC or higher.

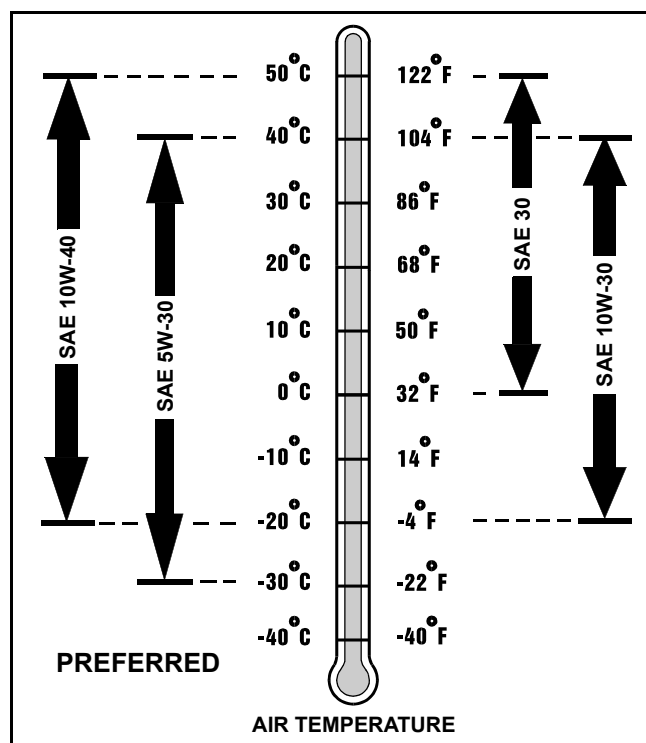

MIF

Break-In Engine Oil - 4-Cycle Gasoline

IMPORTANT: Avoid damage! ONLY use a quality break-in oil in rebuilt or remanufactured engines for the first 5 hours (maximum) of operation. DO NOT use oils with heavier viscosity weights than SAE 5W-30 or oils meeting specifications API SG or SH, these oils will not allow rebuilt or remanufactured engines to break-in properly.

The following John Deere oil is **PREFERRED**:

- **BREAK - IN ENGINE OIL.**

John Deere BREAK - IN ENGINE OIL is formulated with special additives for aluminum and cast iron type engines to allow the power cylinder components (pistons, rings, and liners as well) to “wear-in” while protecting other engine components, valve train and gears, from abnormal wear. Engine rebuild instructions should be followed closely to determine if special requirements are necessary.

John Deere BREAK - IN ENGINE OIL is also recommended for non-John Deere engines, both aluminum and cast iron types.

The following John Deere oil is **also recommended**:

- **TORQ - GARD SUPREME® - SAE 5W-30.**

If the above recommended John Deere oils are not available, use a break-in engine oil meeting the following specification during the first **5 hours (maximum)** of operation:

- SAE 5W-30 - API Service Classification SE or higher.

IMPORTANT: Avoid damage! After the break-in period, use the John Deere oil that is recommended for this engine.

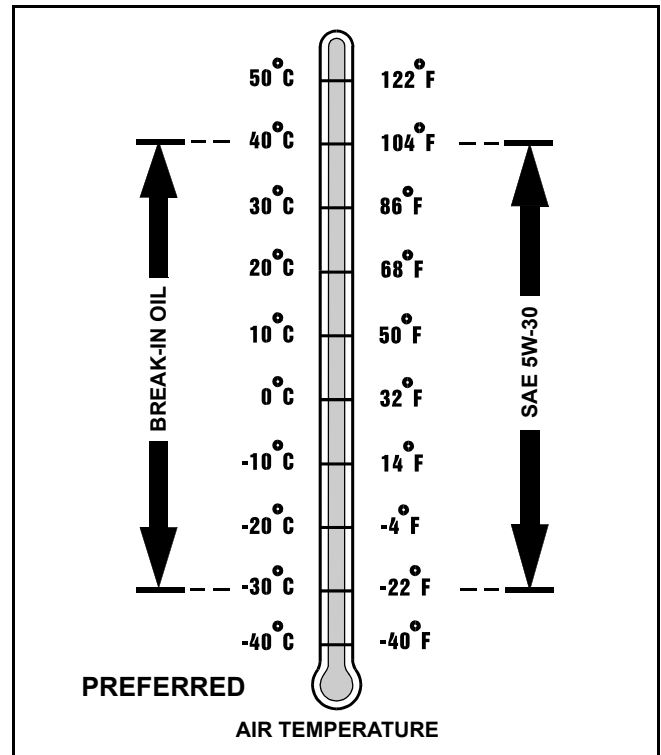

MIF

Hydrostatic Transmission and Hydraulic Oil

Use the appropriate oil viscosity based on these air temperature ranges. Operating outside of these recommended oil air temperature ranges may cause premature hydrostatic transmission or hydraulic system failures.

IMPORTANT: Avoid damage! Mixing of LOW VISCOSITY HY - GARD® and HY - GARD® oils is permitted. DO NOT mix any other oils in this transmission. DO NOT use engine oil or “Type F” (Red) Automatic Transmission Fluid in this transmission. DO NOT use BIO-HY-GARD® in this transmission.

The following John Deere transmission and hydraulic oil is **PREFERRED**:

- **LOW VISCOSITY HY-GARD® - JDM J20D.**

The following John Deere oil is also recommended if above preferred oil is not available:

- **HY-GARD® - JDM J20C.**

Other oils may be used if above recommended John Deere oils are not available, provided they meet one of the following specifications:

- John Deere Standard JDM J20D;
- John Deere Standard JDM J20C.

SPECIFICATIONS & INFORMATION GENERAL INFORMATION

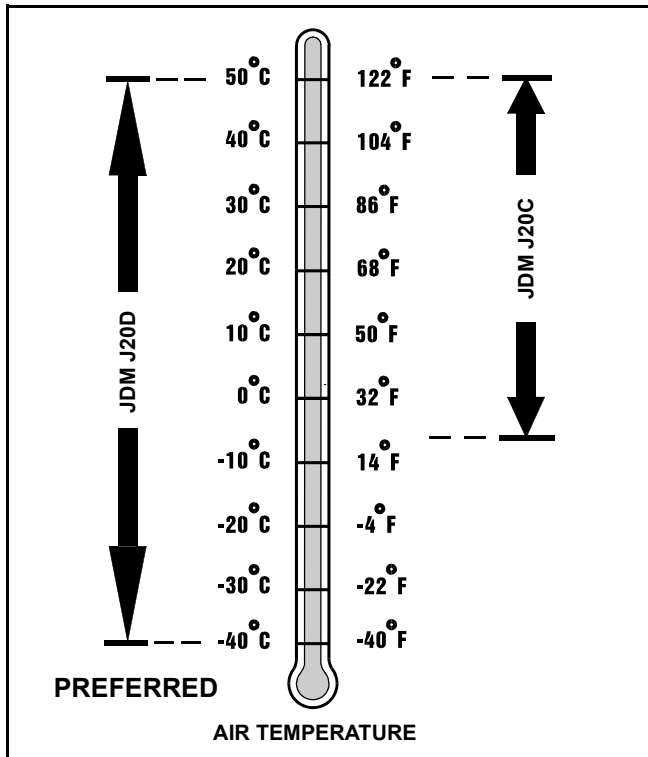

MIF

Gear Case Oil

Use the appropriate oil viscosity based on the air temperature ranges. Operating outside of these recommended oil air temperature ranges may cause premature gear case failure.

IMPORTANT: Avoid damage! ONLY use a quality oil in this gear case. DO NOT mix any other oils in this gear case. DO NOT use BIO-HY-GARD® in this gear case.

The following John Deere gear case oil is **PREFERRED**:

- **GL-5 GEAR LUBRICANT® - SAE 80W-90.**

The following John Deere gear case oil is also recommended if above preferred oil is not available:

- **GL-5 GEAR LUBRICANT® - SAE 85W-140.**

Other gear case oils may be used if above recommended John Deere gear case oils are not available, provided they meet the following specification:

- API Service Classification GL - 5.

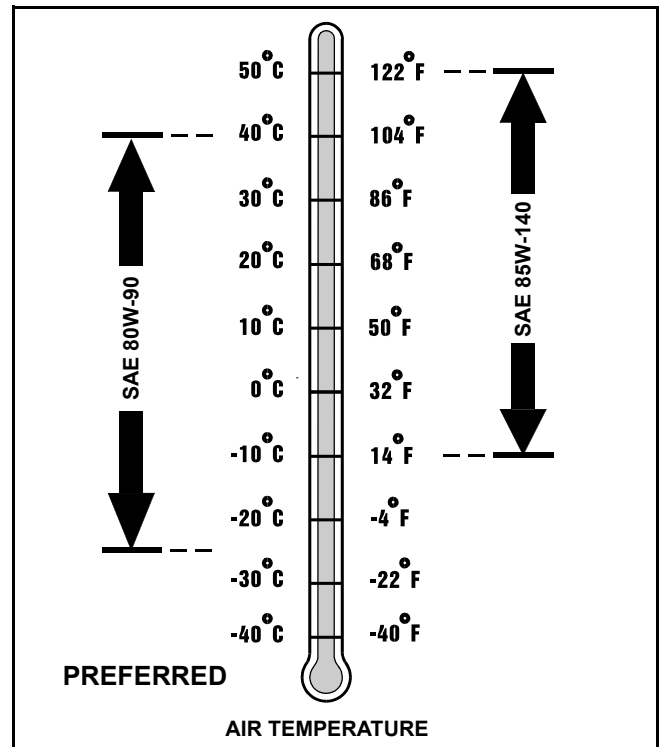

MIF

Gear Transmission Grease

Use the following gear grease based on the air temperature range. Operating outside of the recommended grease air temperature range may cause premature gear transmission failure.

IMPORTANT: Avoid damage! ONLY use a quality gear grease in this transmission. DO NOT mix any other greases in this transmission. DO NOT use any BIO - GREASE in this transmission.

The following John Deere gear grease is PREFERRED:

- **NON-CLAY HIGH-TEMPERATURE EP GREASE®** - JDM J13E4, NLGI Grade 2.

Other greases may be used if above preferred John Deere grease is not available, provided they meet the following specification:

- John Deere Standard JDM J13E4, NLGI Grade 2.

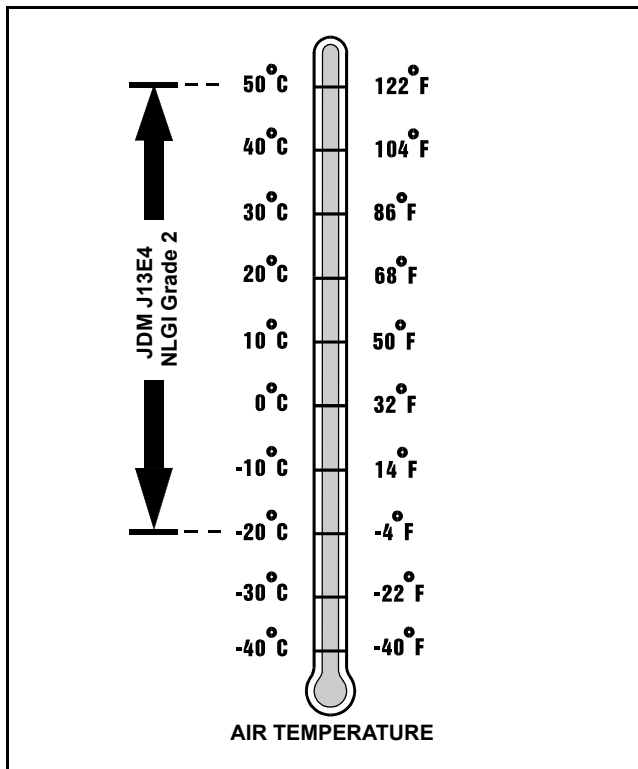

MIF

Alternative Lubricants

Use of alternative lubricants could cause reduced life of the component.

If alternative lubricants are to be used, it is recommended that the factory fill be thoroughly removed before switching to any alternative lubricant.

Synthetic Lubricants

Synthetic lubricants may be used in John Deere equipment if they meet the applicable performance requirements (industry classification and/or military specification) as shown in this manual.

The recommended air temperature limits and service or lubricant change intervals should be maintained as shown in the operator's manual, unless otherwise stated on lubricant label.

Avoid mixing different brands, grades, or types of oil. Oil manufacturers blend additives in their oils to meet certain specifications and performance requirements. Mixing different oils can interfere with the proper functioning of these additives and degrade lubricant performance.

Lubricant Storage

All machines operate at top efficiency only when clean lubricants are used. Use clean storage containers to handle all lubricants. Store them in an area protected from dust, moisture, and other contamination. Store drums on their sides. Make sure all containers are properly marked as to their contents. Dispose of all old, used containers and their contents properly.

Mixing of Lubricants

In general, avoid mixing different brands or types of lubricants. Manufacturers blend additives in their lubricants to meet certain specifications and performance requirements. Mixing different lubricants can interfere with the proper functioning of these additives and lubricant properties which will downgrade their intended specified performance.

Oil Filters

IMPORTANT: Avoid damage! Filtration of oils is critical to proper lubrication performance. Always change filters regularly.

The following John Deere oil filters are PREFERRED:

- AUTOMOTIVE AND LIGHT TRUCK ENGINE OIL FILTERS.

Most John Deere filters contain pressure relief and anti-drainback valves for better engine protection.

Other oil filters may be used if above recommended John Deere oil filters are not available, provided they meet the following specification:

- ASTB Tested In Accordance With SAE J806.

SPECIFICATIONS & INFORMATION COOLANT SPECIFICATIONS

Coolant Specifications

Gasoline Engine Coolant

The engine cooling system when filled with a proper dilution mixture of anti-freeze and deionized or distilled water provides year-round protection against corrosion, cylinder or liner pitting, and winter freeze protection down to **-37°C (-34°F)**.

The following John Deere coolant is **PREFERRED**:

- **COOL-GARD® PRE-DILUTED SUMMER COOLANT (TY16036).**

This coolant satisfies specifications for “Automobile and Light Duty Engine Service” and is safe for use in John Deere Lawn and Grounds Care/Golf and Turf Division equipment, including aluminum block gasoline engines and cooling systems.

The above preferred pre-diluted anti-freeze provides:

- adequate heat transfer
- corrosion-resistant chemicals for the cooling system
- compatibility with cooling system hose and seal material
- protection during extreme cold and extreme hot weather operations
- chemically pure water for better service life
- compliance with ASTM D4656 (JDM H24C2) specifications

If above preferred pre-diluted coolant is not available, the following John Deere concentrate is recommended:

- **COOL-GARD® CONCENTRATED SUMMER COOLANT CONCENTRATE™ (TY16034).**

If either of above recommended engine coolants are available use any Automobile and Light Duty Engine Service ethylene glycol base coolant, meeting the following specification:

- ASTM D4985 (JDM H24A2).

Read container label completely before using and follow instructions as stated.

IMPORTANT: Avoid damage! To prevent engine damage, DO NOT use pure anti-freeze or less than a 50% anti-freeze mixture in the cooling system. DO NOT mix or add any additives/conditioners to the cooling system in Lawn and Grounds Care/Golf and Turf Division equipment. Water used to dilute engine coolant concentrate must be of high quality - clean, clear, potable water (low in chloride and hardness - Table 1) is generally acceptable. DO NOT use salt water. Deionized or distilled water is ideal to use. Coolant that is not mixed to these specified levels and water purity can cause excessive scale, sludge deposits, and increased corrosion potential.

Property	Requirements
Total Solids, Maximum	340 ppm (20 grns/gal)
Total Hardness, Maximum	170 ppm (10 grns/gal)
Chloride (as Cl), Maximum	40 ppm (2.5 grns/gal)
Sulfate (as SO4), Maximum	100 ppm (5.8 grns/gal)

Mix 50 percent anti-freeze concentrate with 50 percent distilled or deionized water. This mixture and the pre-diluted mixture (TY16036) will protect the cooling system down to **-37°C (-34°F)** and up to **108°C (226°F)**.

Certain geographical areas may require lower air temperature protection. See the label on your anti-freeze container or consult your John Deere dealer to obtain the latest information and recommendations.

Gasoline Engine Coolant Drain Interval

When using John Deere Pre-Diluted (TY16036) Automobile and Light Duty Engine Service coolants, drain and flush the cooling system and refill with fresh coolant mixture every 36 months or 3,000 hours of operation, whichever comes first.

When using John Deere Concentrate (TY16034) Automobile and Light Duty Engine Service coolants, drain and flush the cooling system and refill with fresh coolant mixture every 24 months or 2,000 hours of operation, whichever comes first.

If above John Deere Automobile and Light Duty Engine Service coolants are not being used; drain, flush, and refill the cooling system according to instructions found on product container or in equipment operator’s manual or technical manual.

Serial Number Locations

Product Serial Number



M55444

The 13-digit product identification number (A) is located on the right-hand side frame, just below engine compartment.

Gasoline Engine Serial Number Location

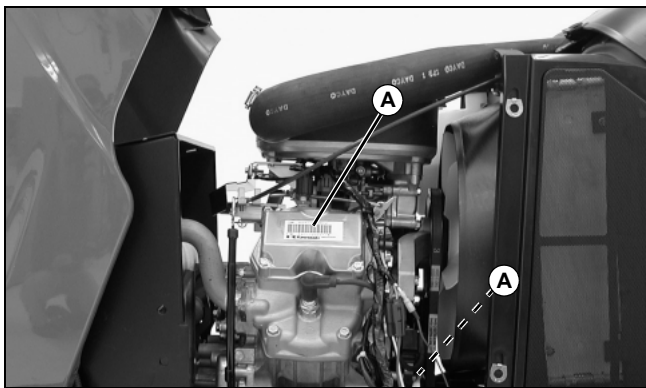

MX13637

Engine serial number (A) is located on the valve cover or on the front of the engine crankcase.

ENGINE - GAS (AIR-COOLED) TABLE OF CONTENTS

Table of Contents

Specifications	23
General Specifications	23
Tests & Adjustments Specifications	23
Repair Specifications.....	24
Torque Specifications (Alphabetical).....	25
Special or Required Tools	26
Component Location	27
Engine - 21 HP (FH641D)	27
Theory of Operation	28
Carburated Engine Fuel and Air System Operation.....	28
Governor Operation.....	28
Lubrication System Operation	29
Troubleshooting	30
Engine Troubleshooting Guide.....	30
Engine Runs Erratically/Loss Of Power	31
Starting Motor Troubleshooting Guide	31
Diagnostics	33
Diagnostic Table.....	33
Tests and Adjustments	35
Throttle Cable Adjustment.....	35
Choke Adjustment	35
Governor Adjustment	36
Low Idle Speed Adjustment.....	36
High Idle Speed Adjustment.....	36
Compression Test	37
Valve Clearance Adjustment	38
Crankcase Vacuum Test	39
Fuel Flow Test.....	40
Oil Pressure Test.....	41
Spark Test	42
Engine Repair	42
Fuel Pump Removal and Installation.....	42
Fuel Pump/Fuel Filter Inspection.....	43
Air Cleaner - Removal/Inspection/ Installation	43
Carburetor Removal and Installation.....	44
Carburetor Disassembly/Assembly	45
Carburetor Clean/Inspect/Rebuild:	50
Intake Manifold Removal and Installation.....	50
Muffler Removal and Installation	51
Engine Removal and Installation.....	52
Cylinder Head Removal and Installation	55

Push Rod and Rocker Arm Removal and Installation.....	57
Valve Train Removal and Installation	58
Piston Removal and Installation	59
Inspect Piston and Cylinder	61
Cylinder Bore Honing.....	64
Cylinder Bore Resizing	64
Crankcase Cover Removal and Installation.	65
Crankcase Cover Inspection.....	67
Governor Assembly Removal/Replacement	67
Governor Assembly Inspection.....	69
Camshaft/Tappet Removal and Installation	69
Camshaft Disassembly/Inspection	70
Crankshaft Removal/Replacement	72
Crankshaft Inspection	73
Connecting Rod Inspection	74
Breather Valve Removal and Installation.....	75
Breather Valve Inspection.....	76
Oil Pump Removal and Installation.....	76
Oil Pump Inspection.....	77
Oil Pickup Removal and Installation	78
Oil Screen Inspection/Cleaning	78
Flywheel Removal and Installation	79
Stator Coil Inspection.....	81
Ignition Coil Removal and Installation.....	81
Starting Motor Removal and Installation.....	82
Starting Motor Solenoid Tests	82
Starting Motor Test	83
Starter Motor Disassembly/Assembly.....	83
Starting Motor Inspection.....	86

ENGINE - GAS (AIR-COOLED) TABLE OF CONTENTS

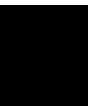

ENGINE - GAS (AIR-COOLED) SPECIFICATIONS

Specifications

General Specifications

Model	Kawasaki
Model Number	FH641D
Power	15.7 kW (21 HP)
Displacement	675 cc (41.2 cu-in.)
Cylinders	2
Stroke/Cycle	4
Valves	Overhead Valves
Bore	75.2 mm (2.96 in.)
Stroke	76 mm (2.99 in.)
Compression Ratio	8: 1
Compression Release	Automatic
Crankshaft Type	Horizontal, Counterbalanced
Lubrication	Pressurized, Positive Displacement Pump
Oil Pressure	241 – 310 kPa (35 – 45 psi)
Oil Filter	Cartridge Type, Full Flow, Spin-On Filter
Crankcase Capacity (With Filter)	1.8 L (1.9 qt)
Cooling System	Air Cooled
Air Cleaner	Dual Element, Replaceable Paper
Muffler	Horizontal, Discharge Below Frame
Slow Idle	1600 ± 25 rpm
Fast Idle	3550 ± 25 rpm
Maximum Angle of Operation (Full Crankcase):	
Continuous (All Directions)	20°
Intermittent (All Directions)	35°
Fuel Filter	Replaceable, In-Line Type
Fuel Pump	Engine Mounted Diaphragm-type Pulse Pump
Fuel Shut-Off Solenoid	Replaceable (Below Carburetor Float Bowl)
Carburetor	Float type, Fixed Main Jet, Two Barrel
Spark Plug	Champion RCJ8Y
Charging System	12V – 13 Amps with Regulator
Weight	44.5 kg (98.1 lbs)

Tests & Adjustments Specifications

Engine

Spark Plug Gap	1.0 mm (0.040 in.)
Valve Adjustment	0.075 – 0.125 mm (0.003 – 0.005 in.)
Oil Pressure (Minimum at 1250 rpm)	241 - 310 kPa (35 to 45 psi)
Cylinder Compression (Minimum, with Engine Warm)	390 kPa (57 psi)

ENGINE - GAS (AIR-COOLED) SPECIFICATIONS

Fuel/Air System:

Slow Idle Speed	1600 ± 25 rpm
Fast Idle Speed	3550 ± 25 rpm

Repair Specifications

Cylinder Head:

Cylinder Head Flatness (Maximum Warp)	0.050 mm (0.002 in.)
---	----------------------

Valves and Valve Lifters:

Valve Clearance (Intake/Exhaust Cold)	0.075 – 0.125 mm (0.003 – 0.005 in.)
Valve Stem Runout (Maximum)	0.050 mm (0.002 in.)
Intake Valve Stem OD (Minimum)	5.95 mm (0.234 in.)
Exhaust Valve Stem OD (Minimum)	5.93 mm (0.233 in.)

Valve Guide:

Intake and Exhaust ID (Maximum)	6.08 mm (0.239 in.)
Valve Spring Free Length (Minimum)	31.0 mm (1.22 in.)
Valve Face Angle	45°
Push Rod Runout (Maximum)	0.5 mm (0.02 in.)

Crankshaft:

Crankshaft Journal Bearing ID: Crankcase	40.15 mm (1.581 in.)
Crankshaft Journal OD (Minimum):	
PTO Side	39.896 mm (1.571 in.)
Flywheel Side	39.896 mm (1.571 in.)
Crankshaft Runout (TIR) (Maximum)	0.05 mm (0.002 in.)
Crankpin OD (Minimum)	39.94 mm (1.572 in.)
Crankpin Width (Maximum)	43.1 mm (1.697 in.)

Connecting Rod:

Twist (Maximum)	0.15 mm over 100 mm (0.006 over 3.94 in.)
Bend (Maximum)	0.15 mm over 100 mm (0.006 over 3.94 in.)
Connecting Rod Big End Width (Maximum)	20.45 mm (0.805 in.)

Camshaft:

Crankcase Bearing ID (Maximum)	16.14 mm (0.635 in.)
Crankcase Cover Bearing ID (Maximum)	16.14 mm (0.635 in.)
Camshaft Journal Diameter:	
PTO Side (Minimum)	15.985 mm (0.6293 in.)
Flywheel Side (Minimum)	15.985 mm (0.6293 in.)
Cam Lobe Height (Minimum):	
Intake	29.621 mm (1.166 in.)
Exhaust	29.621 mm (1.166 in.)

Oil Pump:

Inner And Outer Rotor Clearance (Maximum)	0.2 mm (0.008 in.)
Outer rotor OD (Minimum)	40.47 mm (1.593 in.)

ENGINE - GAS (AIR-COOLED) SPECIFICATIONS

Outer Rotor Thickness (Minimum)	9.83 mm (0.387 in.)
Pump Housing ID (Maximum)	40.801 mm (1.6063 in.)
Pump Housing Depth (Maximum)	10.230 mm (0.4028 in.)
Pump Shaft OD (Minimum)	10.923 mm (0.4300 in.)
Pump Shaft Bearing ID (Maximum)	11.07 mm (0.4358 in.)
Relief Valve Spring Length (Minimum)	19.50 mm (0.77 in.)

Cylinder Bore, Pistons and Rings

Cylinder Bore ID:

New	75.18 – 75.20 mm (2.960 – 2.961 in.)
Maximum	75.28 mm (2.964 in.)
Cylinder Bore Out of Round (Maximum)	0.056 mm (0.0022 in.)
Piston Pin Bore ID (Maximum)	16.08 mm (0.633 in.)
Piston Pin OD (Minimum)	15.96 mm (0.628 in.)
Top Compression Ring-To-Groove Side Clearance	0.18 mm (0.007 in.)
Middle Compression Ring-To-Groove Side Clearance	0.16 mm (0.006 in.)
Piston Ring Thickness (Top, Second) (Minimum)	1.40 mm (0.055 in.)
Top Ring End Gap (Maximum)	0.65 mm (0.026 in.)
Second Ring End Gap (Maximum)	0.78 mm (0.031 in.)
Oil Ring End Gap (Maximum)	1.05 mm (0.041 in.)
Piston OD (Minimum)	74.99 mm (2.952 in.)

Torque Specifications (Alphabetical)

NOTE: Use a torque wrench that reads within the range given. Convert pound-inches to pound-feet as follows:
pound-inches/12 = pound-feet

Air Cleaner Mounting Bolts	5.9 N•m (52 lb-in.)
Camshaft Breather Chamber Cover Bolts	5.9 N•m (52 lb-in.)
Carburetor-to-Manifold Mounting Bolts and Nuts	5.9 N•m (52 lb-in.)
Choke Valve Screw (use non-permanent thread locker)	0.95 N•m (8.4 lb-in.)
Control Panel Mounting Bolts	5.9 N•m (52 lb-in.)
Crankcase Cover Bolts	25 N•m (18 lb-ft.)
Cylinder Head Bolts	25 N•m (18 lb-ft)
Drain Screw (Carburetor)	2 N•m (18 lb-in.)
Engine Drain Plug (Plastic)	6.9 N•m (61 lb-in.)
Engine Drain Plug (Metal)	20 N•m (15 lb-ft)
Engine Drain Plug Joint (Plastic)	17 N•m (12 lb-ft)
Engine Drain Plug Joint (Metal)	39 N•m (29 lb-ft)
Engine Shroud Bolt (M8)	6.9 N•m (61 lb-in.)
Engine Shroud Bolt (M6)	5.9 N•m (52 lb-in.)
Engine Oil Screen Bolt	5.9 N•m (52 lb-in.)
Fan Housing Bolt (M8)	6.9 N•m (61 lb-in.)
Fan Housing Bolt (M6)	5.9 N•m (52 lb-in.)
Fan Housing Screen Bolt	5.9 N•m (52 lb-in.)

ENGINE - GAS (AIR-COOLED) SPECIFICATIONS

Flywheel Bolt	56 N•m (41 lb-ft)
Fuel Shut Off Solenoid Valve (Carburetor).....	19 N•m (14 lb-ft)
Float Chamber Mounting Screw	4 N•m (35 lb-in.)
Governor Arm Clamp Nut	7.8 N•m (69 lb-in.)
Governor Shaft Plate Screws	2 N•m (17 lb-in.)
Ignition Coil Bolts.....	5.9 N•m (52 lb-in.)
Intake Manifold Mounting Bolts	5.9 N•m (52 lb-in.)
Muffler Flange Nut	15 N•m (11 lb-in.)
Main Jet Plug Nut	18 N•m (13 lb-ft)
Oil Pump Cover Plate Mounting Bolts	5.9 N•m (52 lb-in.)
Oil Pressure Switch	9.8 N•m (87 lb-in.)
Rocker Arm Bolts	28 N•m (21 lb-ft)
Rocker Cover Mounting Bolts	6.9 N•m (61 lb-in.)
Spark Plug	22 N•m (195 lb-in.)
Stator Coil Screws	3.4 N•m (30 lb-in.)
Starter Motor Mounting Bolts	15 N•m (11 lb-in.)
Throttle Valve Screws (use non-permanent thread locker)	0.95 N•m (8.4 lb-in.)
Valve Clearance Lock Screws	6.9 N•m (61 lb-in.)
Regulator Screws	3.4 N•m (30 lb-in.)

Special or Required Tools

Special or Required Tools

Tool Name	Tool No.	Tool Use
6.4 mm (0.25 in.) Drill Bit		Throttle and choke adjustment
Dial Indicator		Automatic compression relief test, Valve inspection
Photo Tachometer	JT05719	Slow idle adjustment
Cylinder Leakdown Tester	JT03502	Cylinder leakdown test
Crankcase Vacuum Test Kit	JT03503	Crankcase vacuum check
Oil Pressure Test Adapter w/ O-ring (required ONLY on engines without test ports)	JT07262	Oil pressure test
Connector	JT05847	
Hose Assembly	JT03017	
Coupler	JT03262	
Gauge, 0 – 700 kPa (0 – 100 psi)	JT07034	
Lapping Tool		Valve lapping

ENGINE - GAS (AIR-COOLED) COMPONENT LOCATION

Component Location

Engine - 21 HP (FH641D)

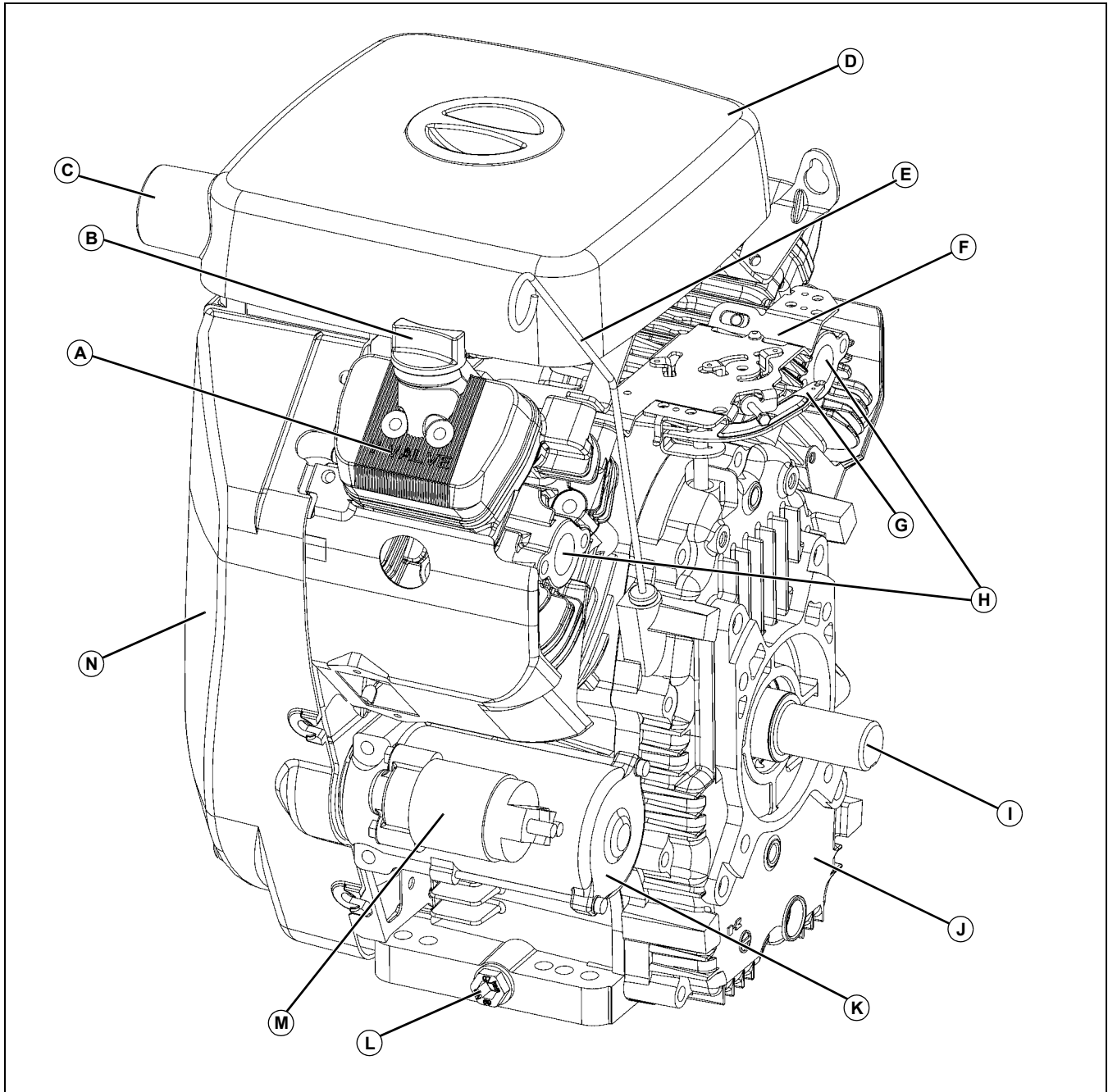

MX14219

- A - Valve Cover
- B - Oil Fill Cap
- C - Air Cleaner Port
- D - Air Cleaner Cover
- E - Dipstick
- F - Throttle Control Plate
- G - Governor Lever

- H - Exhaust Ports
- I - Crankshaft
- J - Crankcase Cover
- K - Starter
- L - Oil Drain Port
- M - Starter Solenoid
- N - Engine Cover

ENGINE - GAS (AIR-COOLED) THEORY OF OPERATION

Theory of Operation

Carburated Engine Fuel and Air System Operation

Function:

The fuel system supplies pressurized fuel to the carburetor for combustion. The air intake system filters air needed for combustion.

System Operation:

An diaphragm pulse fuel pump mounted on the engine supplies fuel to the carburetor. The fuel pump draws fuel through the fuel filter and supplies it to the carburetor. The fuel cap is vented to release pressure from the fuel tank.

The ignition delay module is used with the fuel shut-off solenoid to prevent backfire. The ignition delay module allows the spark plugs to fire for one additional second after the key switch is turned off to burn any fuel remaining in the cylinder. When the key switch is turned off, the fuel shut-off solenoid is de-energized.

Air enters the air filter through the side panel screen and air filter inlet hose. The primary and secondary elements filter the air before entering the carburetor. The breather hose vents crankcase fumes into the carburetor for burning to decrease emissions.

Governor Operation

System Operation:

The governor controls engine speed. Governed engine speed is a balance between governor spring tension, set by the throttle control, and actual engine speed, countered by centrifugal force of the governor flyweights. As tension is applied to governor spring, governor linkage opens carburetor throttle shaft and plate, increasing engine rpm. As the engine speed increases, flyweight assembly (driven by the crankshaft gear) pushes on governor arm, rotating governor shaft and lever, moving throttle shaft, closing throttle plate slightly and reducing rpm to governed operating speed. If a heavy load is encountered, engine speed drops, as does the governor assembly speed. Flyweights retract and allow the shaft arm to move the governor shaft and lever in the opposite direction, opening the throttle plate and allowing more air into the venturi, drawing in more fuel until engine peak operating speed is recovered. Springs provide a smooth yet responsive transitional control.

IMPORTANT: Avoid damage! Flyweight assembly shaft is pressed into crankcase cover and is not serviceable. If it is damaged or pulled loose, the crankcase cover **MUST BE replaced.**

ENGINE - GAS (AIR-COOLED) THEORY OF OPERATION

Lubrication System Operation

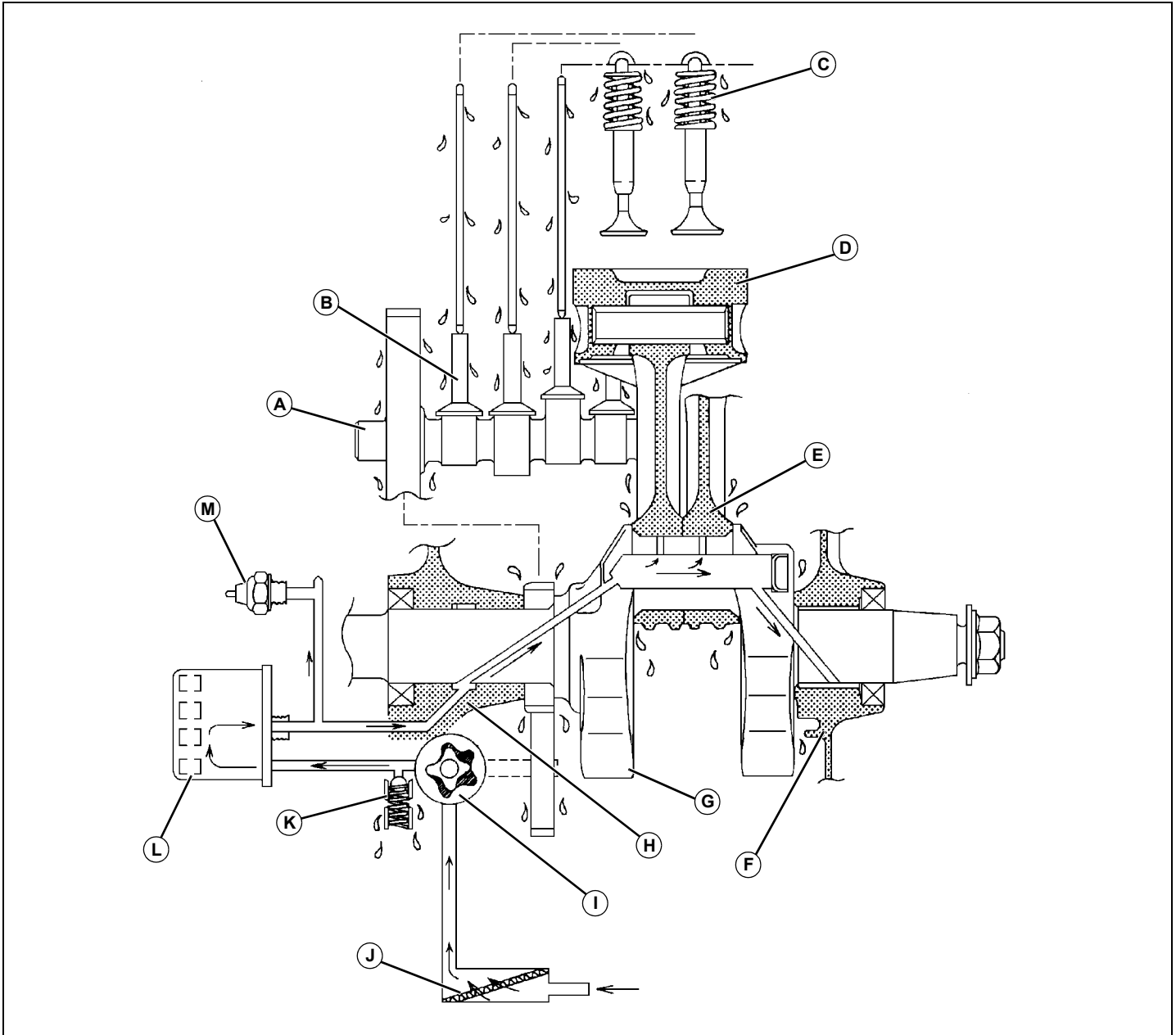

MX14201

System Operation:

A positive displacement gerotor pump (I) is used to pressurize the lubrication system. The lubrication system is protected by an oil pressure relief valve (K), low pressure switch (M), and an oil filter (L) with bypass.

The oil pump (I) draws oil from the sump through a filter screen (J). Pressure oil from the pump flows to the oil pressure relief valve (K). Oil pressure should be 241 – 310 kPa (35 – 45 psi). If the oil pressure exceeds 310 kPa (45 psi), the relief valve opens allowing oil to return to the sump. The relief valve is not adjustable.

Pressure oil from the relief valve flows to the oil filter (L).

The filter contains a bypass valve, which opens if the element becomes plugged to insure engine lubrication.

An oil pressure switch (M) mounted above the oil filter turns on a warning light if oil pressure is below 98 kPa (14.2 psi). Filtered pressure oil flows through a passage in the oil sump to the crankshaft main bearing (H) (PTO side).

Drilled passages in the crankshaft (G) distribute oil from the main bearing to the connecting rod (E) journals and crankshaft main bearing (F) (flywheel side). A drilled passage in the connecting rods allows oil from the connecting rod journal to lubricate the piston (D) and cylinder walls and camshaft (A), tappets (B), and rocker arms and valves (C).

ENGINE - GAS (AIR-COOLED) TROUBLESHOOTING

Troubleshooting

Engine Troubleshooting Guide



CAUTION: Avoid Injury! The engine may start to rotate at any time. Keep hands away from moving parts when testing.

NOTE: To test specific electrical components, see *Electrical Section* and refer to either *Diagnostics or Tests & Adjustments* for further guidance.

Test Conditions:

- Operator On Seat
- PTO Switch In OFF Position
- Brake On

Symptom: Engine Doesn't Crank

(1) Are battery cables loose or dirty?

Yes - Tighten or clean.

No - Go to next step.

(2) Is battery fully charged?

No - Charge battery. See "Battery - Charge" on page 300 in the Electrical section.

Yes - Go to next step.

(3) Is key switch working correctly?

Yes - Go to next step.

No - Test switch. See "Cranking Circuit Operation - All Models" on page 235 in the Electrical section. Replace as needed.

(4) Has engine seized?

Yes - See Engine Repair Section.

No - Go to next step.

(5) Is starting motor or solenoid defective?

Yes - Repair or replace. See "Starter Solenoid Test" on page 305 or "Starting Motor No-load Amperage and RPM Test" on page 306 in the Electrical section.



CAUTION: Avoid injury! Keep spark plug as far away from the plug hole as possible. Gasoline spray from the open cylinders may be ignited by ignition spark and cause an explosion or fire.

IMPORTANT: Avoid damage! Perform a visual inspection first to determine if battery cables are tight and not corroded and if the battery is of sufficient size to turn the engine over at minimum cranking speed of 350 rpm.

Symptom: Engine Hard To Start

(1) Is there a strong blue spark?

Yes - See "Spark Test" on page 324 in the Electrical section. Go to step 3.

No - Replace spark plug. Recheck for spark and go to next step.

(2) Is there a strong blue spark?

Yes - Check engine starting.

No - Check if sparks are produced between high tension lead and ignition block. Check high tension lead, ignition coil air gap, pulsar coil.

(3) Check compression. Is compression sufficient?

Yes - See "Compression Test" on page 37. Make starting attempts a number of times, remove spark plug and observe electrodes. Go to next step.

No - Go to step 5.

(4) After starting attempts, are spark plug electrodes wet?

Yes - Check for excessive use of choke, plugged air cleaner, float bowl level too high.

No - Check fuel tank and lines.

(5) Compression is low?

Yes - Check piston rings and cylinder for wear. See "Piston Removal and Installation" on page 59. Inspect cylinder head.

Symptom: Engine Runs Erratically

(1) Is fuel delivery correct?

Yes - See "Fuel Flow Test" on page 40. Check for plugged air/fuel passages in carburetor. See "Carburetor Clean/Inspect/Rebuild:" on page 50.

No - Check for contamination, or an air or vapor lock in the fuel tank and lines.

Symptom: Engine Malfunctions At Low Speed

(1) Is unusual smoke emitted out of muffler?

Yes - Check choke. See "Choke Adjustment" on page 35.

No - Go to next step.

ENGINE - GAS (AIR-COOLED) TROUBLESHOOTING

Symptom: Engine Malfunctions At Low Speed

(2) Does engine rpm drop or engine stall at a certain point when throttle is gradually opened by hand?

Yes - Plug in carburetor interior, clean carburetor. See "Carburetor Clean/Inspect/Rebuild:" on page 50.

No - Go to next step.

(3) Is air sucked through carburetor or intake manifold flanges?

Yes - Tighten manifold flange nuts or replace damaged gasket.

No - Go to next step.

(4) Are valve clearances set correctly?

No - Adjust valves. See "Valve Clearance Adjustment" on page 38.

Symptom: Oil Consumption Is Excessive

(1) Check compression. Is compression sufficient?

Yes - See "Compression Test" on page 37. Check for oil leaks, high oil level, plugged oil ring groove, oil seals, incorrect oil viscosity.

No - Check for worn, stuck or broken piston rings, or worn cylinder bore.

(2) Is breather valve clean and is oil to correct level?

Yes - Check for clogged breather valve, plugged drain back hole in breather. See "Breather Valve Inspection" on page 76.

No - Check for worn, stuck or broken piston rings, or worn cylinder bore.

Engine Runs Erratically/Loss Of Power

IMPORTANT: Avoid damage! Before proceeding, inspect the mower deck and belts for binding in the spindle assemblies or belts that are too tight/loose. A loose belt, like a loose blade can cause a backlash effect that will counteract engine cranking effort. Excessive drive belt tension may cause premature bearing wear or result in bearing seizure. Grass clippings that build up near the cutting blades can cause excessive resistance and heat build-up that causes problems with the engine's ability to turn the blades at a constant speed. Low lubricant levels in the spindles will build-up heat causing excessive resistance for the engine to deal with.

NOTE: To test specific electrical components, see Electrical Section and refer to either Diagnostics or Tests & Adjustments for further guidance

Starting Motor Troubleshooting Guide



CAUTION: Avoid Injury! The engine may start to rotate at any time. Keep hands away from moving parts when testing.

IMPORTANT: Avoid damage! If starting motor does not by turning ignition switch to Off position, disconnect negative (-) lead from battery as soon as possible.

NOTE: To test specific electrical components, see Electrical Section and refer to either Diagnostics or Tests & Adjustments for further guidance.

Symptom: Starter Does Not Rotate

(1) Is there a click sound from starter solenoid?

Yes - Repair starting motor. See "Starting Motor Removal and Installation" on page 82, and "Starter Motor Disassembly/Assembly" on page 83.

No - Check that all starting conditions are met. Go to next step.

(2) Are battery cables loose or dirty?

Yes - Tighten or clean.

No - Go to next step.

(3) Is battery fully charged?

No - Charge battery. See "Battery - Charge" on page 300 in the Electrical section.

Yes - Go to next step.

ENGINE - GAS (AIR-COOLED) TROUBLESHOOTING

Symptom: Starter Does Not Rotate

(4) Is key switch working correctly?

Yes - Go to next step.

No - Test switch. See "Cranking Circuit Operation - All Models" on page 235 in the Electrical section. Replace as needed.

(5) Has engine seized?

Yes - See Engine Repair Section.

Symptom: Starter Rotates Slowly

(1) Are battery cables loose or dirty?

Yes - Tighten or clean.

No - Go to next step.

(2) Is battery fully charged?

Yes - Go to next step.

No - Charge battery. See "Battery - Charge" on page 300 in the Electrical section.

(3) Has engine seized?

Yes - See Engine Repair Section.

No - Go to next step.

(4) Is starting motor or solenoid defective?

Yes - Repair or replace. See "Starter Solenoid Test" on page 305, or "Starting Motor No-load Amperage and RPM Test" on page 306 in the Electrical section.

ENGINE - GAS (AIR-COOLED) DIAGNOSTICS

Diagnostics

Diagnostic Table

Test Conditions:

- Machine parked on level surface.

- Park brake engaged.
- PTO Switch OFF.
- Key switch OFF unless indicated otherwise.
- Spark plug connected to D-05351ST Spark Tester

Test/Check Point	Normal Condition	If Not Normal
Engine dipstick and exterior engine surface	Oil level between "L" and "H" marks. Oil not burnt, or contaminated with metal particles, fuel, or coolant. No external leakage, filter clean.	Change oil and inspect for source of contamination. Check gaskets, seals, plugs, cylinder head, block, and intake manifold and breather. Change oil filter.
Fuel tank, pump, lines, filter	Fuel level correct, not contaminated; or stale smelling; no water fuel.	Drain and clean fuel tank. Add fresh fuel.
	Fuel pump filter and in-line filter free of debris.	Replace filters.
	Fuel shutoff valve in ON position	Move to ON position
	Fuel hoses not cracked or leaking.	Replace.
	Fuel hose clamps tight.	Replace or tighten.
	Fuel tank does not have vacuum.	Replace vented fuel cap.
Fuel shutoff solenoid (Key in "START" position)	Fuel shutoff solenoid must pull in and stay in when key is returned to ON position. Listen for clicking as key is cycled.	If solenoid will not pull in and hold in, see Fuel Shutoff Solenoid Circuit Diagnosis in Electrical section.
Hand throttle control lever linkage	Full movement of governor control arm from idle to full speed.	Repair; replace or adjust linkage.
Air filter and air intake	Air filter outlet hose not cracked; clamps tight. Elements not plugged. Air filter housing sealed; no dirt tracking inside filter element. Air filter restriction indicator not leaking	Replace hose and/or tighten clamps. Replace element or housing. Replace indicator.
Spark plug (key switch in start position)	Steady blue spark. Engine must crank.	If spark is weak (yellow) or no spark, install new spark plug and test again. If still weak or no spark, see "Ignition Circuit Diagnosis" in Electrical section. See "Cranking Circuit Diagnosis" in the Electrical section.
Spark plug (key switch off)	Plug dry.	Check carburetor inlet needle for debris, choke, and mixture adjustment.

ENGINE - GAS (AIR-COOLED) DIAGNOSTICS

Test/Check Point	Normal Condition	If Not Normal
Intake and exhaust valves	Valve clearance within specification (engine cold). Valves not sticking.	Adjust valves. See "Valve Clearance Adjustment" on page 38. Check valve guides and stems.
Perform cylinder compression test	Cylinder compression within specification. Pressure difference between cylinders within specification.	Rebuild engine.
Flywheel and starting motor	Minimum cranking rpm within specification.	See "Starter Amp Draw Test" in Electrical section.
Carburetor—fuel filter, fuel pump, and carburetor bowl drain screw (key switch on).	Fuel level increases in filter. Fuel pump operating—listen for humming sound near fuel cap. Fuel present in float bowl when screw is opened.	See "Fuel pump and Fuel Shutoff Solenoid Circuit Diagnosis" in the Electrical section. Test fuel pump pressure and flow. Check carburetor for debris.
Carburetor choke and governor linkage	Linkage not binding and adjusted correctly.	Repair, replace or adjust linkage.
Carburetor (engine running)	Low idle at 1550 rpm. High idle at 3600 rpm.	See "Low Idle Speed Adjustment" on page 36, and/or "High Idle Speed Adjustment" on page 36.
Oil pressure switch port	Minimum oil pressure within specifications.	Test engine oil pressure. See "Oil Pressure Test" on page 41.
Muffler	Not restricted.	Replace muffler.

ENGINE - GAS (AIR-COOLED) TESTS AND ADJUSTMENTS

Tests and Adjustments

Throttle Cable Adjustment

Reason:

To make sure the throttle cable moves the throttle and choke control lever through its full range of movement.

Procedure:

1. Set the throttle lever in the slow idle position. Check that the throttle control lever (A) contacts the idle speed adjustment screw (B) at the slowest throttle lever setting.

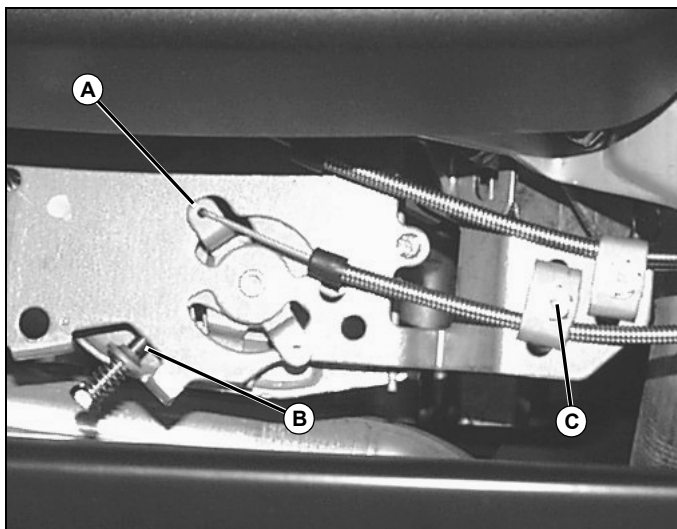

MX11694

2. If the throttle control lever (A) is not touching the screw (B) at the slowest setting, loosen the throttle cable clamp (C). Pull throttle cable to left. When the control lever contacts the control plate idle adjustment screw, retighten the cable clamp.
3. Set the throttle lever to the fastest idle position. Check that the throttle control lever is advancing to the full open position.
4. If the control lever is not advancing to the full open position, loosen the cable clamp and readjust the cable.
5. If the cable cannot be adjusted to obtain the full open throttle lever position at fastest idle, while maintaining contact with the adjustment screw at lowest idle position, it will be necessary to adjust the control plate idle speed adjustment screw.
6. Turn the idle adjustment screw (B) clockwise until it contacts the throttle control lever when set in the slow idle position. After completing the idle screw adjustment, check to make certain the motor is maintaining a 1550 RPM governed low idle setting. Follow the Low Idle Speed Adjustment sequence in this chapter if corrections are necessary.

Choke Adjustment

Reason:

To make sure the choke plate is fully closed when the choke lever is in the full choke position. Correct adjustment also makes sure choke is completely open in the fast idle position.

Procedure:

NOTE: Adjust throttle cable before adjusting choke.

1. Remove air cleaner assembly.

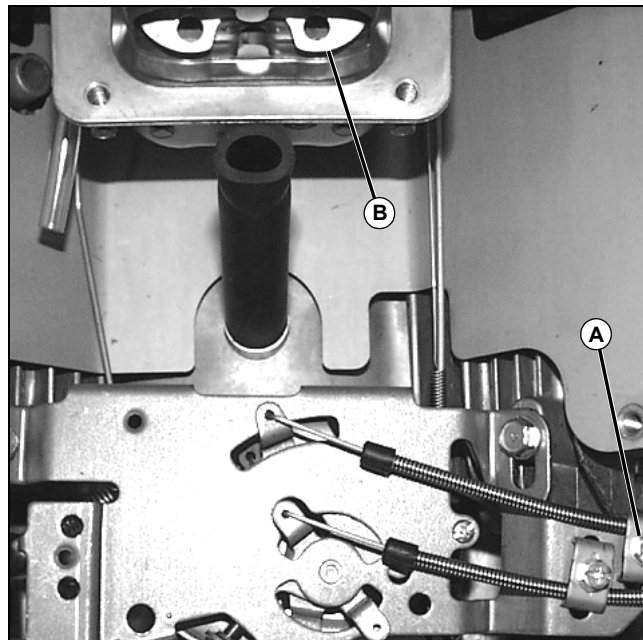

MX11695

2. Move choke lever forward to full choke position. Check that the choke butterfly (B) in the carburetor is fully closed.
3. If adjustment is necessary, loosen the choke cable clamp (A). Move the cable to obtain a fully closed position. Retighten the cable clamp.
4. Release the choke lever and make certain the return spring on the governor control plate is returning the choke butterfly to the fully open position.
5. Reinstall the air cleaner assembly and check the choke operation while starting the machine.

ENGINE - GAS (AIR-COOLED) TESTS AND ADJUSTMENTS

Governor Adjustment

Reason:

To make sure the governor shaft contacts the flyweight plunger when the engine is stopped.

NOTE: Adjust throttle cable before adjusting governor linkage.

Procedure:

NOTE: It is not necessary to remove the throttle or choke cables from the governor plate assembly to reach the governor arm. The governor plate can be swung away with the cables installed when accessing the governor arm components.

1. Remove governor plate assembly.

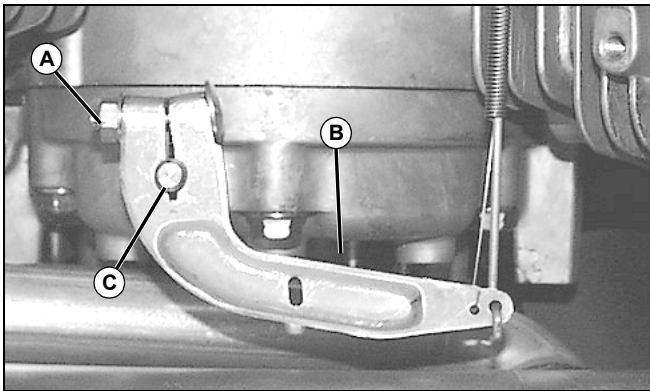

MX11696

2. Loosen nut (A) holding the governor arm (B) to the governor shaft.
3. Turn the governor arm full counterclockwise and hold.
4. Turn the governor shaft (C) full counterclockwise and hold.
5. Tighten nut.

Low Idle Speed Adjustment

Reason:

To set engine slow idle mixture rpm.

Equipment:

- JTO5719 Photo Tachometer

Procedure:

1. Disconnect all external loads from engine.
2. Put reflective tape on blower housing screen.
3. Start and run engine at medium idle for five minutes.



CAUTION: Avoid Injury! Engine will be HOT. Be careful not to burn skin.

4. Move throttle lever to idle position. Hold the throttle lever on the carburetor in the closed position (turn governor arm clockwise all the way).
5. Adjust the low idle speed screw (A) until the engine idles at 1450 rpm (carburetor idle rpm). Use the photo tachometer to check engine rpm at the blower housing screen.

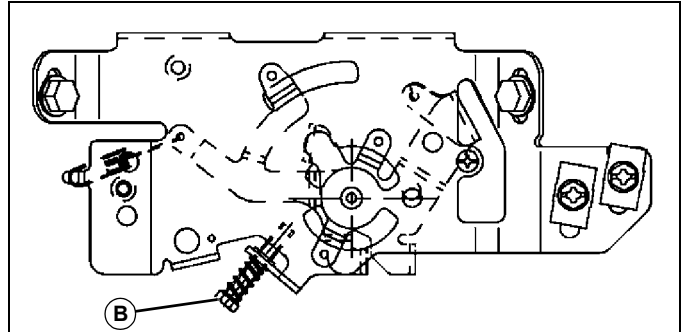

MX11674

6. Release the throttle lever and adjust the low idle speed set screw (B) on the control plate to obtain a 1550 rpm governed low idle speed.

High Idle Speed Adjustment

Reason:

To set engine high idle mixture and rpm.

Equipment:

- JTO5719 Photo Tachometer
- 6 mm bolt or 1/4" drill bit.

Procedure:



CAUTION: Avoid Injury! Always keep hands clear of moving parts.

1. Move throttle lever to the high idle position.

IMPORTANT: Avoid damage! Do not adjust high idle speed with air cleaner removed.

2. Match the lever hole on the governor control plate with the panel hole (A) and insert the bolt or drill bit.



Suggest:

If the above button click is invalid.

Please download this document

first, and then click the above link

to download the complete manual.

Thank you so much for reading

ENGINE - GAS (AIR-COOLED) TESTS AND ADJUSTMENTS

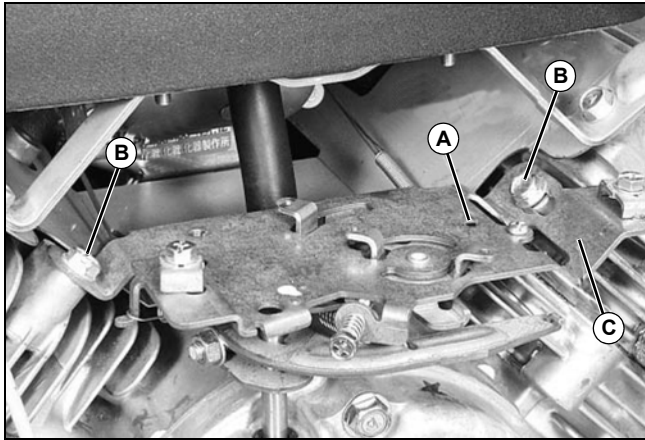

MX11675

3. Loosen the two M6 control panel mounting bolts (B) enough to allow the control panel to move.
4. Slide the control panel up or down in the slot at the right side (C) to set the idle speed.
5. Use a photo tachometer to check engine rpm at the blower housing screen.
6. Set the high idle speed at 3600 RPM and tighten the M6 mounting bolts to 5.9 Nm (52 lb-in.).
7. Remove the bolt or drill bit from the panel hole.
8. Recheck the idle speed and readjust if necessary.

Specifications:

High idle setting	3600 rpm
Carburetor idle setting	1450 rpm
Governed idle setting	1550 rpm

NOTE: For high altitude operation above 4000 feet, use high altitude carburetor kit, to prevent over rich fuel mixture and black exhaust smoke.

Compression Test

Reason:

To determine the condition of pistons, rings, cylinder walls and valves.

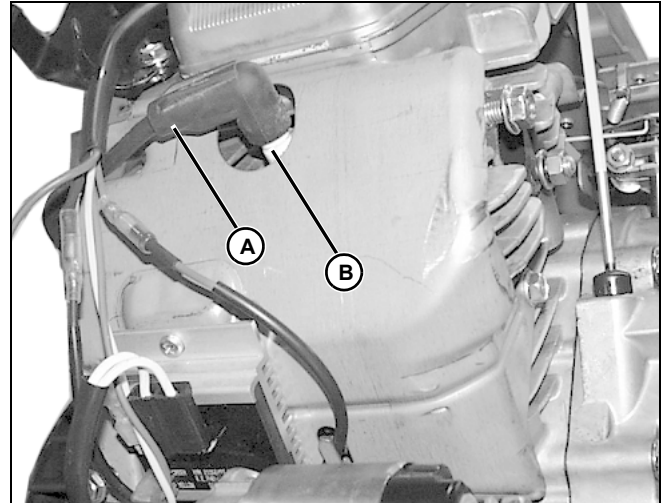

MX11780

Procedure:

1. Adjust valve clearance to 0.075 – 0.125 mm (0.003 – 0.005 in.) with engine at top dead center (TDC) compression stroke. Engine must be “cold” (shop temperature, 60 – 86°F (16 – 30°C)).
2. Run engine until it reaches operating temperature.
3. Remove both spark plugs (B) and ground leads (A) to block or use spark testers.
4. Put throttle lever in fast idle (wide open) position. Choke must be properly adjusted and fully open. Air filter must be clean.

IMPORTANT: Avoid damage! DO NOT overheat starting motor during test. Starter duty is 5 seconds on, 10 seconds off.

5. Attach compression gauge to engine, and crank hot engine until highest compression reading is obtained.
6. Record pressure readings for each cylinder.

Specifications:

Minimum Compression 390 kPa (57 psi)

Results:

- If pressure readings are above specification, adjust valves and check fuel and intake air systems. Check exhaust for restriction.
- If pressure readings are below specification, squirt clean engine oil into cylinders and repeat test.

<https://www.ebooklibonline.com>

Hello dear friend!

Thank you very much for reading.

Enter the link into your browser.

The full manual is available for immediate download.

<https://www.ebooklibonline.com>