

**LX172, LX173, LX176,
LX178, LX186 & LX188
Lawn Tractors**

**TECHNICAL
MANUAL**

**John Deere
Lawn & Grounds Care Division**

TM1492 (31MAY96)

This technical manual is written for an experienced technician and contains sections that are specifically for this product. It is a part of a total product support program.

The manual is organized so that all the information on a particular system is kept together. The order of grouping is as follows:











- Table of Contents
- Specifications
- Component Location
- System Schematic
- Theory of Operation
- Troubleshooting Chart
- Diagnostics
- Tests & Adjustments
- Repair

Note: Depending on the particular section or system being covered, not all of the above groups may be used.

Each section will be identified with a tab symbol rather than a number. The groups and pages within a section will be consecutively numbered.

All information, illustrations and specifications in this manual are based on the latest information available at the time of publication. The right is reserved to make changes at any time without notice.

We appreciate your input on this manual. To help, there are postage paid post cards included at the back. If you find any errors or want to comment on the layout of the manual please fill out one of the cards and mail it back to us.

Safety	
Specifications and Information	
Engine—Kawasaki	
Engine—Kohler	
Electrical	
Power Train (Gear)	
Power Train (Hydrostatic)	
Steering	
Brakes	
Attachments	
Miscellaneous	M

COPYRIGHT© 1996
 JOHN DEERE HORICON WORKS
 Horicon, Wisconsin
 All rights reserved



RECOGNIZE SAFETY INFORMATION



This is the safety-alert symbol. When you see this symbol on your machine or in this manual, be alert to the potential for personal injury.

Follow recommended precautions and safe servicing practices.

Understand Signal Words

A signal word—DANGER, WARNING, or CAUTION—is used with the safety-alert symbol. DANGER identifies the most serious hazards.

DANGER or WARNING safety signs are located near specific hazards. General precautions are listed on CAUTION safety signs. CAUTION also calls attention to safety messages in this manual.

REPLACE SAFETY SIGNS



Replace missing or damaged safety signs. See the machine operator's manual for correct safety sign placement.

HANDLE FLUIDS SAFELY-AVOID FIRES

Be Prepared For Emergencies

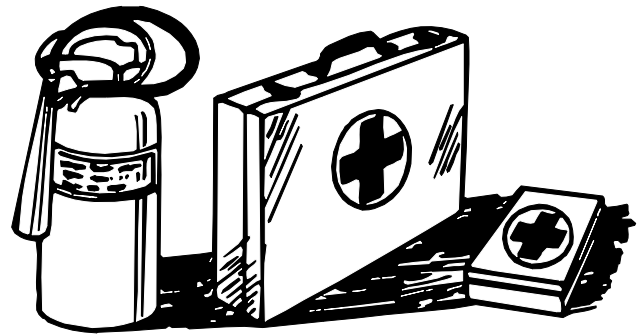

When you work around fuel, do not smoke or work near heaters or other fire hazards.

Store flammable fluids away from fire hazards. Do not incinerate or puncture pressurized containers.

Make sure machine is clean of trash, grease, and debris.

Do not store oily rags; they can ignite and burn spontaneously.

Be prepared if a fire starts.

Keep a first aid kit and fire extinguisher handy.

Keep emergency numbers for doctors, ambulance service, hospital, and fire department near your telephone.

<https://www.ebooklibonline.com>

Hello dear friend!

Thank you very much for reading.

Enter the link into your browser.

The full manual is available for immediate download.

<https://www.ebooklibonline.com>

USE CARE IN HANDLING AND SERVICING BATTERIES

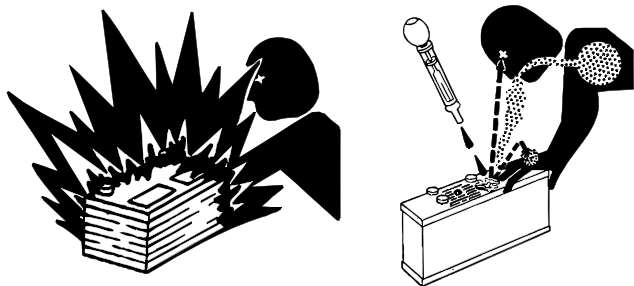

Prevent Battery Explosions

- Keep sparks, lighted matches, and open flame away from the top of battery. Battery gas can explode.
- Never check battery charge by placing a metal object across the posts. Use a volt-meter or hydrometer.
- Do not charge a frozen battery; it may explode. Warm battery to 16°C (60°F).

Prevent Acid Burns

- Sulfuric acid in battery electrolyte is poisonous. It is strong enough to burn skin, eat holes in clothing, and cause blindness if splashed into eyes.
- **Avoid acid burns by:**
 1. Filling batteries in a well-ventilated area.
 2. Wearing eye protection and rubber gloves.
 3. Avoiding breathing fumes when electrolyte is added.
 4. Avoiding spilling or dripping electrolyte.
 5. Use proper jump start procedure.
- **If you spill acid on yourself:**
 1. Flush your skin with water.
 2. Apply baking soda or lime to help neutralize the acid.
 3. Flush your eyes with water for 10-15 minutes.
 4. Get medical attention immediately.
- **If acid is swallowed:**
 1. Drink large amounts of water or milk.
 2. Then drink milk of magnesia, beaten eggs, or vegetable oil.
 3. Get medical attention immediately.

USE SAFE SERVICE PROCEDURES

Wear Protective Clothing

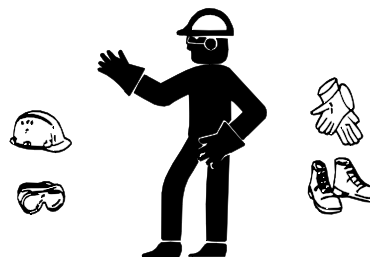

Wear close fitting clothing and safety equipment appropriate to the job.

Prolonged exposure to loud noise can cause impairment or loss of hearing. Wear a suitable hearing protective device such as earmuffs or earplugs to protect against objectionable or uncomfortable loud noises.

Operating equipment safely requires the full attention of the operator. Do not wear radio or music headphones while operating machine.

Service Machines Safely

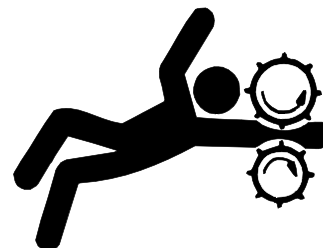

Tie long hair behind your head. Do not wear a necktie, scarf, loose clothing, or necklace when you work near machine tools or moving parts. If these items were to get caught, severe injury could result.

Remove rings and other jewelry to prevent electrical shorts and entanglement in moving parts.

Use Proper Tools

Use tools appropriate to the work. Makeshift tools and procedures can create safety hazards. Use power tools only to loosen threaded parts and fasteners. For loosening and tightening hardware, use the correct size tools. **DO NOT** use U.S. measurement tools on metric fasteners. Avoid bodily injury caused by slipping wrenches. Use only service parts meeting John Deere specifications.



Park Machine Safely

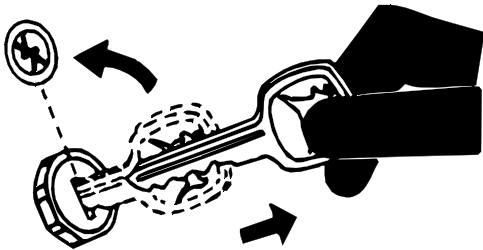

Before working on the machine:

1. Lower all equipment to the ground.
2. Stop the engine and remove the key.
3. Disconnect the battery ground strap.
4. Hang a "DO NOT OPERATE" tag in operator station.

Support Machine Properly And Use Proper Lifting Equipment

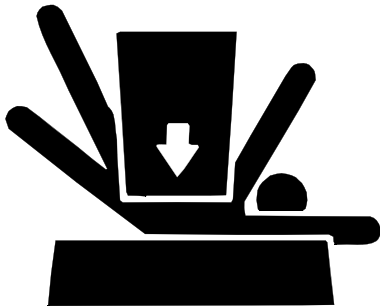

If you must work on a lifted machine or attachment, securely support the machine or attachment.

Do not support the machine on cinder blocks, hollow tiles, or props that may crumble under continuous load. Do not work under a machine that is supported solely by a jack. Follow recommended procedures in this manual.

Lifting heavy components incorrectly can cause severe injury or machine damage. Follow recommended procedure for removal and installation of components in the manual.

Work In Clean Area

Before starting a job:

1. Clean work area and machine.
2. Make sure you have all necessary tools to do your job.
3. Have the right parts on hand.
4. Read all instructions thoroughly; do not attempt shortcuts.

Using High Pressure Washers

Directing pressurized water at electronic/electrical components or connectors, bearings, hydraulic seals, fuel injection pumps or other sensitive parts and components may cause product malfunctions. Reduce pressure and spray at a 45 to 90 degree angle.

Illuminate Work Area Safely

Illuminate your work area adequately but safely. Use a portable safety light for working inside or under the machine. Make sure the bulb is enclosed by a wire cage. The hot filament of an accidentally broken bulb can ignite spilled fuel or oil.

Work In Ventilated Area

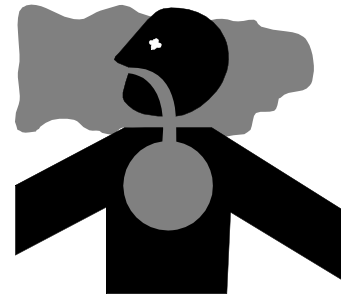

Engine exhaust fumes can cause sickness or death. If it is necessary to run an engine in an enclosed area, remove the exhaust fumes from the area with an exhaust pipe extension.

If you do not have an exhaust pipe extension, open the doors and get outside air into the area.

WARNING: California Proposition 65 Warning

Gasoline engine exhaust from this product contains chemicals known to the State of California to cause cancer, birth defects, or other reproductive harm.

Remove Paint Before Welding Or Heating

Avoid potentially toxic fumes and dust. Hazardous fumes can be generated when paint is heated by welding, soldering, or using a torch. Do all work outside or in a well ventilated area. Dispose of paint and solvent properly. Remove paint before welding or heating: If you sand or grind paint, avoid breathing the dust. Wear an approved respirator. If you use solvent or paint stripper, remove stripper with soap and water before welding. Remove solvent or paint stripper containers and other flammable material from area. Allow fumes to disperse at least 15 minutes before welding or heating.

Avoid Harmful Asbestos Dust

Avoid breathing dust that may be generated when handling components containing asbestos fibers. Inhaled asbestos fibers may cause lung cancer.

Components in products that may contain asbestos fibers are brake pads, brake band and lining assemblies, clutch plates, and some gaskets. The asbestos used in these components is usually found in a resin or sealed in some way. Normal handling is not hazardous as long as airborne dust containing asbestos is not generated.

Avoid creating dust. Never use compressed air for cleaning. Avoid brushing or grinding material containing asbestos. When servicing, wear an approved respirator. A special vacuum cleaner is recommended to clean asbestos. If not available, apply a mist of oil or water on the material containing asbestos. Keep bystanders away from the area.

SERVICE TIRES SAFELY



Explosive separation of a tire and rim parts can cause serious injury or death.

Do not attempt to mount a tire unless you have the proper equipment and experience to perform the job. Always maintain the correct tire pressure. Do not inflate the tires above the recommended pressure. Never weld or heat a wheel and tire assembly. The heat can cause an increase in air pressure resulting in a tire explosion. Welding can structurally weaken or deform the wheel.

When inflating tires, use a clip-on chuck and extension hose long enough to allow you to stand to one side and NOT in front of or over the tire assembly. Use a safety cage if available.

Check wheels for low pressure, cuts, bubbles, damaged rims or missing lug bolts and nuts.

AVOID INJURY FROM ROTATING BLADES, AUGERS AND PTO SHAFTS

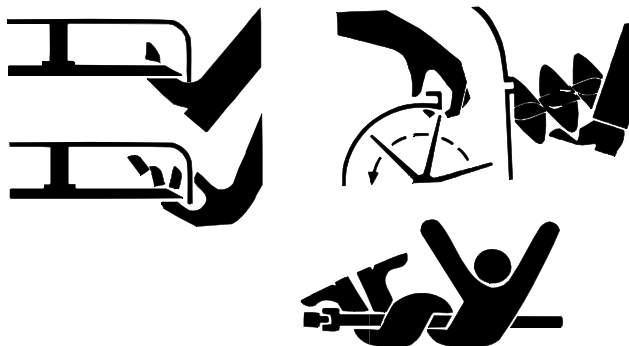

Keep hands and feet away while machine is running. Shut off power to service, lubricate or remove mower blades, augers or PTO shafts.

SERVICE COOLING SYSTEM SAFELY

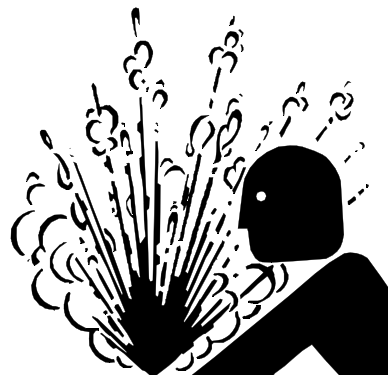

Explosive release of fluids from pressurized cooling system can cause serious burns.

Shut off machine. Only remove filler cap when cool enough to touch with bare hands. Slowly loosen cap to first stop to relieve pressure before removing completely.



HANDLE CHEMICAL PRODUCTS SAFELY

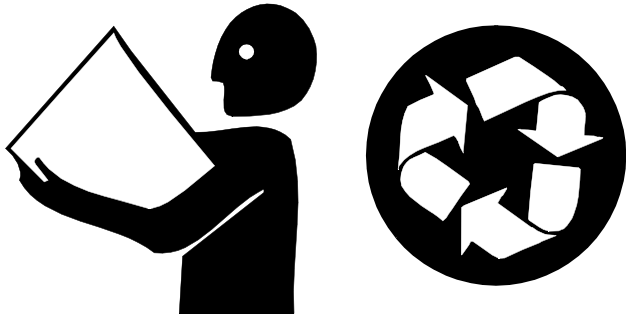

Direct exposure to hazardous chemicals can cause serious injury. Potentially hazardous chemicals used with John Deere equipment include such items as lubricants, coolants, paints, and adhesives.

A Material Safety Data Sheet (MSDS) provides specific details on chemical products: physical and health hazards, safety procedures, and emergency response techniques. Check the MSDS before you start any job using a hazardous chemical. That way you will know exactly what the risks are and how to do the job safely. Then follow procedures and recommended equipment.

Dispose of Waste Properly

Improperly disposing of waste can threaten the environment and ecology. Potentially harmful waste used with John Deere equipment include such items as oil, fuel, coolant, brake fluid, filters, and batteries. Use leakproof containers when draining fluids. Do not use food or beverage containers that may mislead someone into drinking from them. Do not pour waste onto the ground, down a drain, or into any water source. Inquire on the proper way to recycle or dispose of waste from your local environmental or recycling center, or from your John Deere dealer.

LIVE WITH SAFETY



Before returning machine to customer, make sure machine is functioning properly, especially the safety systems. Install all guards and shields.

CONTENTS

Page

SPECIFICATIONS AND GENERAL INFORMATION

GENERAL VEHICLE SPECIFICATIONS

VEHICLE SPECIFICATIONS 2-2

METRIC FASTENER TORQUE VALUES 2-7

INCH FASTENER TORQUE VALUES 2-8

GASOLINE

4-CYCLE ENGINES—NORTH AMERICA 2-9

GASOLINE STORAGE 2-9

4-CYCLE ENGINES—EUROPE 2-10

GASOLINE STORAGE 2-10

OILS AND LUBRICANTS

KAWASAKI 4-CYCLE GASOLINE ENGINE OIL—NORTH AMERICA 2-11

KAWASAKI 4-CYCLE GASOLINE ENGINE OIL—EUROPE 2-12

KOHLER 4-CYCLE GASOLINE ENGINE OIL—NORTH AMERICA 2-13

KOHLER 4-CYCLE GASOLINE ENGINE OIL—EUROPE 2-13

BREAK-IN 4-CYCLE GASOLINE ENGINE OIL—NORTH AMERICA 2-14

BREAK-IN 4-CYCLE GASOLINE ENGINE OIL—EUROPE 2-15

HYDROSTATIC TRANSMISSION OIL—NORTH AMERICA 2-16

HYDROSTATIC TRANSMISSION OIL—EUROPE 2-16

GEAR TRANSMISSION GREASE —NORTH AMERICA 2-17

GEAR TRANSMISSION GREASE—EUROPE 2-17

GREASE—NORTH AMERICA 2-18

GREASE—EUROPE 2-18

ANTI-CORROSION GREASE—NORTH AMERICA 2-19

ANTI-CORROSION GREASE—EUROPE 2-19

ALTERNATIVE LUBRICANTS 2-20

SYNTHETIC LUBRICANTS 2-20

LUBRICANT STORAGE 2-20

MIXING OF LUBRICANTS 2-20

OIL FILTERS 2-20

GASOLINE ENGINE COOLANT—NORTH AMERICA 2-21

GASOLINE ENGINE COOLANT DRAIN INTERVAL—NORTH AMERICA 2-21

GASOLINE ENGINE COOLANT—EUROPE 2-22

GASOLINE ENGINE COOLANT DRAIN INTERVAL—EUROPE 2-22

SERIAL NUMBER LOCATIONS

MACHINE IDENTIFICATION NUMBER 2-23

ENGINE SERIAL NUMBER—LX172, LX176 AND LX186 2-23

ENGINE SERIAL NUMBER—LX173 2-23

ENGINE SERIAL NUMBER—LX178 AND LX188 2-23

CARBURETOR SERIAL NUMBER—LX172, LX176 AND LX186 2-23

CARBURETOR PART NUMBER—LX173 (ONLY) 2-23

CARBURETOR SERIAL NUMBER—LX178 AND LX188 2-24

GEAR TRANSAXLE SERIAL NUMBER—LX172 AND LX173 2-24

HYDROSTATIC TRANSAXLE SERIAL NUMBER
—LX176, LX178, LX186 AND LX188 2-24

MOWER DECK SERIAL NUMBERS 2-24



GENERAL VEHICLE SPECIFICATIONS

ENGINE—LX172 AND LX176

Make	John Deere "K" Series
Type	Gasoline
Model	FC420V
Aspiration	Natural
Horsepower	10.4 kW (14 hp)
Cylinders	1
Displacement	423 mL (25.8 cu. in.)
Stroke/Cycle	4 Cycle
Bore	89 mm (3.500 in.)
Stroke	68 mm (2.68 in.)
Slow Idle	1550 ±75 rpm
Fast Idle	3350 ±50 rpm
Valving	Overhead Valves
Lubrication	Pressurized
Oil Filter	Full Flow Filter
Engine Oil Capacity (with filter)	1.50 L (3.2 U.S. pt)
Cooling System	Air Cooled
Air Cleaner	Two-stage with replaceable filter element
Muffler	Horizontal discharge below frame

ENGINE—LX173

Make	Kohler
Series	Command LT
Type	Gasoline
Model	CV15S
Aspiration	Natural
Horsepower	11.19 kW (15.0 hp)
Cylinders	1
Displacement	426 cc (26.0 cu. in.)
Stroke/Cycle	4 Cycle
Bore	90 mm (3.60 in.)
Stroke	67 mm (2.64 in.)
Slow Idle	1650 ±75 rpm
Fast Idle (Domestic)	3350 ±50 rpm
Valving	Overhead Valves
Lubrication	Pressurized
Oil Filter	Full Flow Filter (w/o By-Pass Valve)
Engine Oil Capacity (with filter)	1.8 L (1.9 U.S. qt)
Cooling System	Air Cooled
Air Cleaner	Paper with outer foam element
Muffler	Horizontal discharge below frame
Compression Release	Automatic/Centrifugal
Compression Ratio (Cranking)	2:1
Compression Ratio (Running)	8.5:1

ENGINE—LX178

Make John Deere "K" Series
 Type Gasoline
 Model FD440V
 Aspiration Natural
 Horsepower 11.1 kW (15 hp)
 Cylinders 2 (V-twin)
 Displacement 437 mL (26.7 cu. in.)
 Stroke/Cycle 4 Cycle
 Bore 67 mm (2.34 in.)
 Stroke 62 mm (2.44 in.)
 Slow Idle 1550 ±75 rpm
 Fast Idle 3400 ±75 rpm
 Valving Overhead Valves
 Lubrication Pressurized
 Oil Filter Full Flow Filter
 Engine Oil Capacity (with filter) 1.50 L (3.2 U.S. pt)
 Cooling System Liquid Cooled
 Air Cleaner Two-stage with replaceable filter element
 Muffler Horizontal discharge below frame

ENGINE—LX186

Make John Deere "K" Series
 Type Gasoline
 Model FC540V
 Aspiration Natural
 Horsepower 10.4 kW (14 hp)
 Cylinders 1
 Displacement 423 mL (25.8 cu. in.)
 Stroke/Cycle 4 Cycle
 Bore 89 mm (3.50 in.)
 Stroke 68 mm (2.680 in.)
 Slow Idle 1550 ±75 rpm
 Fast Idle 3350 ±50 rpm
 Valving Overhead Valves
 Lubrication Pressurized
 Oil Filter Full Flow Filter
 Engine Oil Capacity (with filter) 1.80 L (3.8 U.S. pt.)
 Cooling System Air Cooled
 Air Cleaner Two-stage with replaceable filter element
 Muffler Horizontal discharge below frame



POWER TRAIN

Drive Wheels Rear
 Transaxle Drive Belt

Gear Transaxle—LX172/ LX173

Type Gear Transaxle
 Number of Speeds 5 Forward, 1 Reverse
 Travel Speeds at Full RPM
 1st Gear 2.6 km/h (1.6 mph)
 2nd Gear 4.1 km/h (2.5 mph)
 3rd Gear 6.1 km/h (3.8 mph)
 4th Gear 7.8 km/h (4.8 mph)
 5th Gear 9.2 km/h (5.7 mph)
 Reverse 4.4 km/h (2.7 mph)
 Transaxle Lubricant Capacity 2.3 L (2.5 qt)
 Lubricant Type John Deere Non-Clay High-Temperature EP Grease

Hydrostatic Transaxle—LX176/ LX178/LX186/LX188

Type Hydrostatic, Piston-Type Transaxle
 Transaxle Filter Replaceable, Internal
 Travel Speeds at Full RPM
 Forward 0—8.8 km/h (0—5.5 mph)
 Reverse 0—4.0 km/h (0—2.5 mph)
 Transaxle Lubricant Capacity 3.4 L (7.2 U.S. qt)
 Lubricant Type John Deere TURF-GARD® 10W-30 Engine Oil

STEERING

Type Sector and Pinion

BRAKES

Location Transaxle
 Type
 LX172/LX173 External Disk, Single Pedal
 LX176/LX178/LX186/LX188 External Band, Single Pedal
 Park Brake
 LX172/LX173 Right Pedal, Clutch Interlock
 LX176/LX178/LX186/LX188 Right Pedal

IMPLEMENT LIFT

Lift System Manual with Lift-Assist Spring
 Lift Lever Location Left-hand side of hood
 Cutting Heights 12.7—88.9 mm (12.7 mm increments)
 0.5—3.5 in. (0.50 in. increments)



WEIGHTS AND DIMENSIONS

Net Weight (no fuel) (estimated)

LX172/LX173

With 38-Inch Mower Deck 238 kg (525 lb)

With 44-Inch Mower Deck 245 kg (540 lb)

With 48-Inch Mower Deck 254 kg (560 lb)

LX176

With 38-Inch Mower Deck 243 kg (535 lb)

With 48-Inch Mower Deck 259 kg (570 lb)

LX178

With 38-Inch Mower Deck 245 kg (540 lb)

With 44-Inch Mower Deck 261 kg (575 lb)

LX186/LX188

With 48-Inch Mower Deck 268 kg (590 lb)

Mower Deck Weight (estimated)

38-Inch Mower Deck 43 kg (95 lb)

44-Inch Mower Deck 49 kg (108 lb)

48-Inch Mower Deck 57 kg (125 lb)

Overall Width (less mower deck)

LX172/LX173/LX176/LX178 1.262 m (49.7 in.)

LX186/LX188 1.504 m (59.2 in.)

Overall Width (with mower deck, discharge chute down)

With 38-Inch Mower Deck 1.32 m (52 in.)

With Rear Bagger 1.26 m (49.5 in.)

With 44-Inch Mower Deck 1.163 m (45.7 in.)

With 48-Inch Mower Deck 1.54 m (60.5 in.)

With Power Flow 1.56 m (61.5 in.)

Overall Height 1.02 m (40.2 in.)

Overall Length 1.68 m (66.1 in.)

Wheelbase 1.165 m (45.9 in.)

Turning Radius

Inside Rear Wheel 0.508 m (20 in.)

Outside Front Wheel 1.88 m (74 in.)

WHEELS AND TIRES

Front 15 x 6.00-6 in.

Rear 20 x 10.00-8 in.



METRIC FASTENER TORQUE VALUES

Property Class and Head Markings	4.8		8.8		9.8		10.9		12.9	
Property Class and Nut Markings	5		10		10		10		12	

TS1163

SIZE	Class 4.8				Class 8.8 or 9.8				Class 10.9				Class 12.9			
	Lubricated ^a		Dry ^a		Lubricated ^a		Dry ^a		Lubricated ^a		Dry ^a		Lubricated ^a		Dry ^a	
	N•m	lb-ft	N•m	lb-ft	N•m	lb-ft	N•m	lb-ft	N•m	lb-ft	N•m	lb-ft	N•m	lb-ft	N•m	lb-ft
M6	48	3.5	6	4.5	9	6.5	11	8.5	13	9.5	17	12	15	11.5	19	14.5
M8	12	8.5	15	11	22	16	28	20	32	24	40	30	37	28	47	35
M10	23	17	29	21	43	32	55	40	63	47	80	60	75	55	95	70
M12	40	29	50	37	75	55	95	70	110	80	140	105	130	95	165	120
M14	63	47	80	60	120	88	150	110	175	130	225	165	205	150	260	109
M16	100	73	125	92	190	140	240	175	275	200	350	225	320	240	400	300
M18	135	100	175	125	260	195	330	250	375	275	475	350	440	325	560	410
M20	190	140	240	180	375	275	475	350	530	400	675	500	625	460	800	580
M22	260	190	330	250	510	375	650	475	725	540	925	675	850	625	1075	800
M24	330	250	425	310	650	475	825	600	925	675	1150	850	1075	800	1350	1000
M27	490	360	625	450	950	700	1200	875	1350	1000	1700	1250	1600	1150	2000	1500
M30	675	490	850	625	1300	950	1650	1200	1850	1350	2300	1700	2150	1600	2700	2000
M33	900	675	1150	850	1750	1300	2200	1650	2500	1850	3150	2350	2900	2150	3700	2750
M36	1150	850	1450	1075	2250	1650	2850	2100	3200	2350	4050	3000	3750	2750	4750	3500

DO NOT use these hand torque values if a different torque value or tightening procedure is given for a specific application. Torque values listed are for general use only and include a ±10% variance factor. Check tightness of fasteners periodically. DO NOT use air powered wrenches.

Shear bolts are designed to fail under predetermined loads. Always replace shear bolts with identical grade.

Fasteners should be replaced with the same grade. Make sure fastener threads are clean and that you properly start thread engagement. This will prevent them from failing when tightening.

When bolt and nut combination fasteners are used, torque values should be applied to the **NUT** instead of the bolt head.









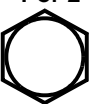

Tighten toothed or serrated-type lock nuts to the full torque value.

^a "Lubricated" means coated with a lubricant such as engine oil, or fasteners with phosphate and oil coatings. "Dry" means plain or zinc plated (yellow dichromate - Specification JDS117) without any lubrication.

Reference: JDS—G200.

INCH FASTENER TORQUE VALUES



SAE Grade and Head Markings	1 or 2 ^b No Marks 	5  5.1  5.2 	8  8.2 
	2 No Marks 	5  	8  

TS1162

SIZE	Grade 1				Grade 2 ^b				Grade 5, 5.1 or 5.2				Grade 8 or 8.2			
	Lubricated ^a		Dry ^a		Lubricated ^a		Dry ^a		Lubricated ^a		Dry ^a		Lubricated ^a		Dry ^a	
	N•m	lb-ft	N•m	lb-ft	N•m	lb-ft	N•m	lb-ft	N•m	lb-ft	N•m	lb-ft	N•m	lb-ft	N•m	lb-ft
1/4	3.7	2.8	4.7	3.5	6	4.5	7.5	5.5	9.5	7	12	9	13.5	10	17	12.5
5/16	7.7	5.5	10	7	12	9	15	11	20	15	25	18	28	21	35	26
3/8	14	10	17	13	22	16	27	20	35	26	44	33	50	36	63	46
7/16	22	16	28	20	35	26	44	32	55	41	70	52	80	58	100	75
1/2	33	25	42	31	53	39	67	50	85	63	110	80	120	90	150	115
9/16	48	36	60	45	75	56	95	70	125	90	155	115	175	130	225	160
5/8	67	50	85	62	105	78	135	100	170	125	215	160	215	160	300	225
3/4	120	87	150	110	190	140	240	175	300	225	375	280	425	310	550	400
7/8	190	140	240	175	190	140	240	175	490	360	625	450	700	500	875	650
1	290	210	360	270	290	210	360	270	725	540	925	675	1050	750	1300	975
1-1/8	470	300	510	375	470	300	510	375	900	675	1150	850	1450	1075	1850	1350
1-1/4	570	425	725	530	570	425	725	530	1300	950	1650	1200	2050	1500	2600	1950
1-3/8	750	550	950	700	750	550	950	700	1700	1250	2150	1550	2700	2000	3400	2550
1-1/2	1000	725	1250	925	990	725	1250	930	2250	1650	2850	2100	3600	2650	4550	3350

DO NOT use these hand torque values if a different torque value or tightening procedure is given for a specific application. Torque values listed are for general use only and include a ±10% variance factor. Check tightness of fasteners periodically. DO NOT use air powered wrenches.

Shear bolts are designed to fail under predetermined loads. Always replace shear bolts with identical grade.

Fasteners should be replaced with the same grade. Make sure fastener threads are clean and that you properly start thread engagement. This will prevent them from failing when tightening.

When bolt and nut combination fasteners are used, torque values should be applied to the **NUT** instead of the bolt head.

Tighten toothed or serrated-type lock nuts to the full torque value.

^a "Lubricated" means coated with a lubricant such as engine oil, or fasteners with phosphate and oil coatings. "Dry" means plain or zinc plated (yellow dichromate - Specification JDS117) without any lubrication.

^b "Grade 2" applies for hex cap screws (not hex bolts) up to 152 mm (6-in.) long. "Grade 1" applies for hex cap screws over 152 mm (6-in.) long, and for all other types of bolts and screws of any length.

Reference: JDS—G200.

GASOLINE 4-CYCLE ENGINES—NORTH AMERICA

CAUTION

Gasoline is **HIGHLY FLAMMABLE**, handle it with care.

DO NOT refuel machine while:

- indoors, always fill gas tank outdoors;
- machine is near an open flame or sparks;
- engine is running, **STOP** engine;
- engine is hot, allow it to cool sufficiently first;
- smoking.

Help prevent fires:

- fill gas tank to bottom of filler neck only;
- be sure fill cap is tight after fueling;
- clean up any gas spills **IMMEDIATELY**;
- keep machine clean and in good repair—free of excess grease, oil, debris, and faulty or damaged parts;
- any storage of machines with gas left in tank should be in an area that is well ventilated to prevent possible igniting of fumes by an open flame or spark, this includes any appliance with a pilot light.

To prevent fire or explosion caused by STATIC ELECTRIC DISCHARGE during fueling:

- **ONLY** use a clean, approved **POLYETHYLENE PLASTIC** fuel container and funnel **WITHOUT** any metal screen or filter.

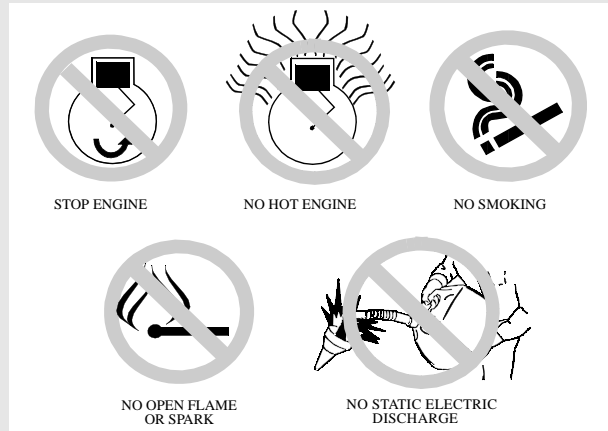

To avoid engine damage:

- DO NOT mix oil with gasoline;
- **ONLY** use clean, fresh unleaded gasoline with an octane rating (anti-knock index) of 87 or higher;
- fill gas tank at the end of each day's operation to help prevent condensation from forming inside a partially filled tank;
- keep up with specified service intervals.

Use of alternative oxygenated, gasohol blended, unleaded gasoline is acceptable as long as:

- the ethyl or grain alcohol blends DO NOT exceed 10% by volume or
- methyl tertiary butyl ether (MTBE) blends DO NOT exceed 15% by volume.



IMPORTANT: DO NOT use METHANOL gasolines because METHANOL is harmful to the environment and to your health.

WARNING

California Proposition 65 Warning: Gasoline engine exhaust from this product contains chemicals known to the State of California to cause cancer, birth defects, or other reproductive harm.

GASOLINE STORAGE

IMPORTANT: Keep all dirt, scale, water or other foreign material out of gasoline.

Keep gasoline stored in a safe, protected area. Storage of gasoline in a clean, properly marked (“**UNLEADED GASOLINE**”) **POLYETHYLENE PLASTIC** container **WITHOUT** any metal screen or filter is recommended. **DO NOT** use de-icers to attempt to remove water from gasoline or depend on fuel filters to remove water from gasoline. Use a water separator installed in the storage tank outlet. **BE SURE** to properly discard unstable or contaminated gasoline. When storing unit or gasoline, it is recommended that you add **John Deere Gasoline Conditioner and Stabilizer (TY15977)** or an equivalent to the gasoline. **BE SURE** to follow directions on container and to properly discard empty container.

4-CYCLE ENGINES—EUROPE

CAUTION

Gasoline is **HIGHLY FLAMMABLE**, handle it with care.

DO NOT refuel machine while:

- indoors, always fill gas tank outdoors;
- machine is near an open flame or sparks;
- engine is running, **STOP** engine;
- engine is hot, allow it to cool sufficiently first;
- smoking.

Help prevent fires:

- fill gas tank to bottom of filler neck only;
- be sure fill cap is tight after fueling;
- clean up any gas spills **IMMEDIATELY**;
- keep machine clean and in good repair—free of excess grease, oil, debris, and faulty or damaged parts;
- any storage of machines with gas left in tank should be in an area that is well ventilated to prevent possible igniting of fumes by an open flame or spark, this includes any appliance with a pilot light.

To prevent fire or explosion caused by STATIC ELECTRIC DISCHARGE during fueling:

- **ONLY** use a clean, approved **POLYETHYLENE PLASTIC** fuel container and funnel **WITHOUT** any metal screen or filter.

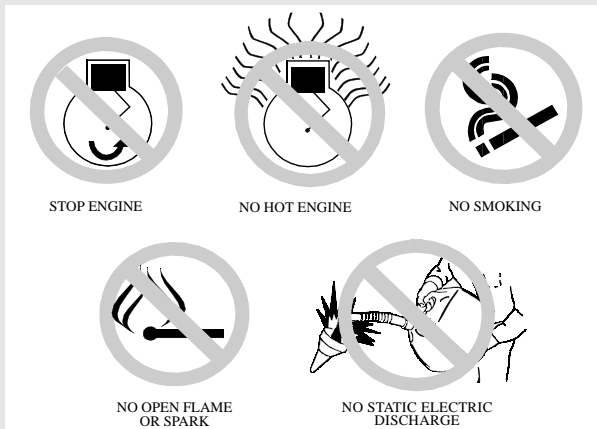

To avoid engine damage:

- **DO NOT** mix oil with gasoline;
- **ONLY** use clean, fresh unleaded gasoline with an octane rating (anti-knock index) of 87 or higher;
- fill gas tank at the end of each day's operation to help prevent condensation from forming inside a partially filled tank;
- keep up with specified service intervals.

Use of alternative oxygenated, gasohol blended, unleaded gasoline is acceptable as long as:

- the ethyl or grain alcohol blends **DO NOT** exceed 10% by volume or
- methyl tertiary butyl ether (MTBE) blends **DO NOT** exceed 15% by volume.

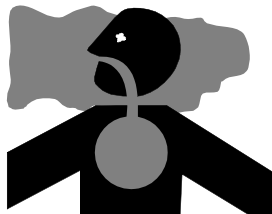

IMPORTANT: **DO NOT** use **METHANOL** gasolines because **METHANOL** is harmful to the environment and to your health.

GASOLINE STORAGE

IMPORTANT: Keep all dirt, scale, water or other foreign material out of gasoline.

Keep gasoline stored in a safe, protected area. Storage of gasoline in a clean, properly marked ("**UNLEADED GASOLINE**") **POLYETHYLENE PLASTIC** container **WITHOUT** any metal screen or filter is recommended. **DO NOT** use de-icers to attempt to remove water from gasoline or depend on fuel filters to remove water from gasoline. Use a water separator installed in the storage tank outlet. **BE SURE** to properly discard unstable or contaminated gasoline. When storing unit or gasoline, it is recommended that you add **John Deere Gasoline Conditioner and Stabilizer (TY15977)** or an equivalent to the gasoline. **BE SURE** to follow directions on container and to properly discard empty container.

OILS AND LUBRICANTS

KAWASAKI 4-CYCLE GASOLINE ENGINE OIL—NORTH AMERICA

Use the appropriate oil viscosity based on the expected air temperature range during the period between recommended oil changes. Operating outside of these recommended oil air temperature ranges may cause premature engine failure.

The following John Deere oils are **PREFERRED**:

- **PLUS-4[®]—SAE 10W-40;**
- **TORQ-GARD SUPREME[®]—SAE 5W-30.**

The following John Deere oils are **also recommended**, based on their specified temperature range:

- **TURF-GARD[®]—SAE 10W-30;**
- **PLUS-4[®]—SAE 10W-30;**
- **TORQ-GARD SUPREME[®]—SAE 30.**

Other oils may be used if above John Deere oils are not available, provided they meet one of the following specifications:

- SAE 10W-40—API Service Classifications SG or higher;
- SAE 5W-30—API Service Classification SG or higher;
- SAE 10W-30—API Service Classifications SG or higher;
- SAE 30—API Service Classification SC or higher.

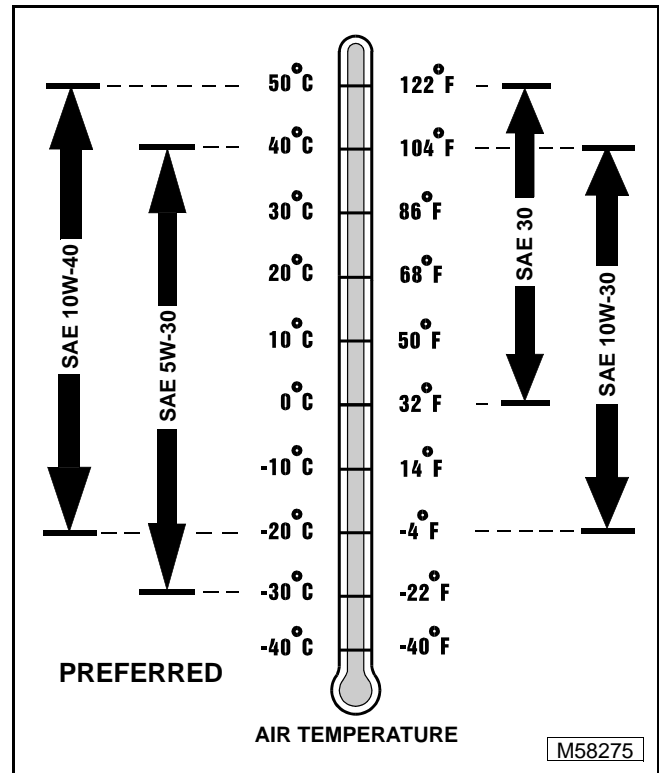

John Deere Dealers: You may want to cross-reference the following publications to recommend the proper oil for your customers:

- Module DX, ENOIL2 in JDS-G135;
- Section 530, Lubricants & Hydraulics, of the John Deere Merchandise Sales Guide;
- Lubrication Sales Manual PI7032.

KAWASAKI 4-CYCLE GASOLINE ENGINE OIL—EUROPE

Use the appropriate oil viscosity based on the expected air temperature range during the period between recommended oil changes. Operating outside of these recommended oil air temperature ranges may cause premature engine failure.

The following John Deere oils are **PREFERRED**:

- TORQ-GARD SUPREME®—SAE 10W-40;
- UNI-GARD™—SAE 10W-40;
- TORQ-GARD SUPREME®—SAE 5W-30;
- UNI-GARD™—SAE 5W-30.

The following John Deere oils are **also recommended**, based on their specified temperature range:

- TORQ-GARD SUPREME®—SAE 10W-30;
- UNI-GARD™—SAE 10W-30;
- TORQ-GARD SUPREME®—SAE 30;
- UNI-GARD™—SAE 30.

Other oils may be used if above John Deere oils are not available, provided they meet one of the following specifications:

- CCMC Specifications G4 or higher.

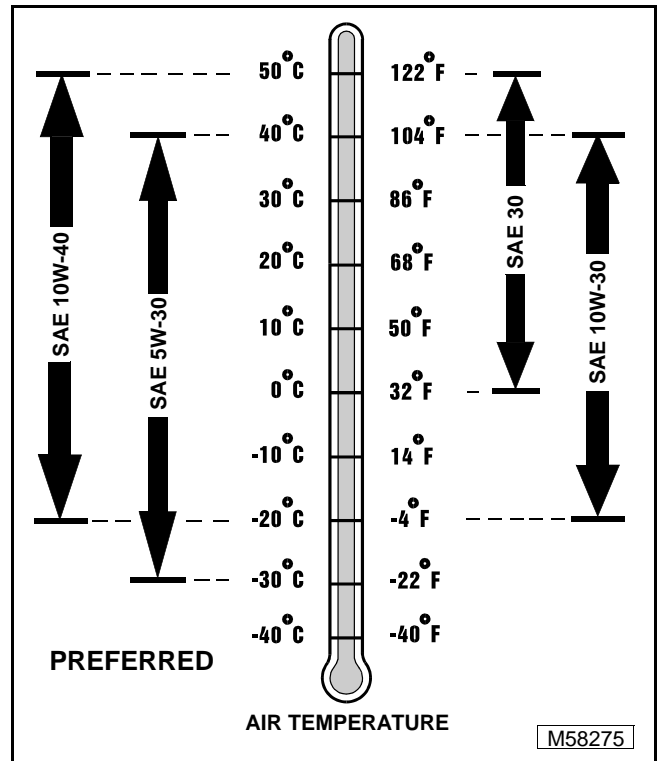

John Deere Dealers: You may want to cross-reference the following publications to recommend the proper oil for your customers:

- Module DX, ENOIL2 in JDS-G135;
- Section 530, Lubricants & Hydraulics, of the John Deere Merchandise Sales Guide.

KOHLER 4-CYCLE GASOLINE ENGINE OIL—NORTH AMERICA

Use the appropriate oil viscosity based on the expected air temperature range during the period between recommended oil changes. Operating outside of these recommended oil air temperature ranges may cause premature engine failure.

The following John Deere oils are **PREFERRED**:

- **PLUS-4[®]**—SAE 10W-40;
- **TURF-GARD[®]**—SAE 10W-30;
- **PLUS-4[®]**—SAE 10W-30;

The following John Deere oil is **also recommended**, based on their specified temperature range:

- **TORQ-GARD SUPREME[®]**—SAE 5W-30.

Other oils may be used if above John Deere oils are not available, provided they meet one of the following specifications:

- SAE 10W-40, 10W-30, or 5W-30—API Service Classifications SG or higher;

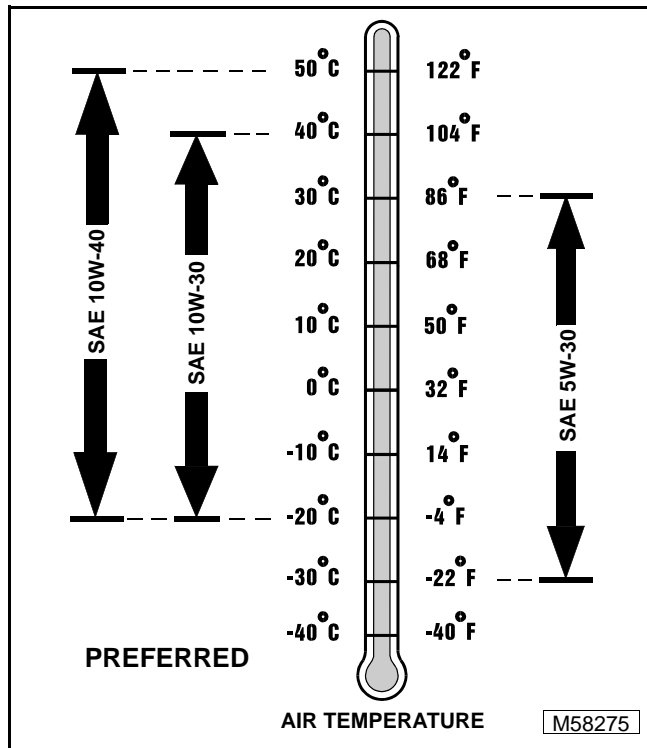

John Deere Dealers: You may want to cross-reference the following publications to recommend the proper oil for your customers:

- Module DX, ENOIL2 in JDS-G135;
- Section 530, Lubricants & Hydraulics, of the John Deere Merchandise Sales Guide;
- Lubrication Sales Manual PI7032.

KOHLER 4-CYCLE GASOLINE ENGINE OIL—EUROPE

Use the appropriate oil viscosity based on the expected air temperature range during the period between recommended oil changes. Operating outside of these recommended oil air temperature ranges may cause premature engine failure.

The following John Deere oils are **PREFERRED**:

- **TORQ-GARD SUPREME[®]**—SAE 10W-40;
- **UNI-GARD[™]**—SAE 10W-40;
- **TORQ-GARD SUPREME[®]**—SAE 10W-30;
- **UNI-GARD[™]**—SAE 10W-30.

The following John Deere oil is **also recommended**, based on their specified temperature range:

- **TORQ-GARD SUPREME[®]**—SAE 5W-30;
- **UNI-GARD[™]**—SAE 5W-30.

Other oils may be used if above John Deere oils are not available, provided they meet one of the following specifications:

- CCMC Specifications G4 or higher.

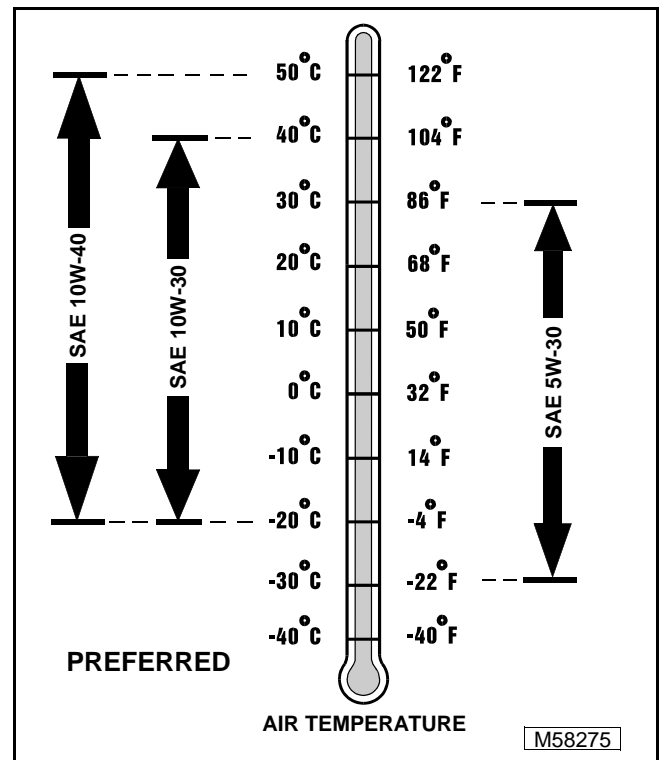

John Deere Dealers: You may want to cross-reference the following publications to recommend the proper oil for your customers:

- Module DX, ENOIL2 in JDS-G135;
- Section 530, Lubricants & Hydraulics, of the John Deere Merchandise Sales Guide.

BREAK-IN 4-CYCLE GASOLINE ENGINE OIL—NORTH AMERICA

IMPORTANT: ONLY use a quality break-in oil in rebuilt or remanufactured engines for the first 5 hours (maximum) of operation. DO NOT use oils with heavier viscosity weights than SAE 5W-30 or oils meeting specifications API SG or SH, these oils will not allow rebuilt or remanufactured engines to break-in properly.

The following John Deere oil is **PREFERRED**:

- **BREAK-IN ENGINE OIL.**

John Deere BREAK-IN ENGINE OIL is formulated with special additives for aluminum and cast iron type engines to allow the power cylinder components (pistons, rings, and liners as well) to “wear-in” while protecting other engine components, valve train and gears, from abnormal wear. Engine rebuild instructions should be followed closely to determine if special requirements are necessary.

John Deere BREAK-IN ENGINE OIL is also recommended for non-John Deere engines, both aluminum and cast iron types.

The following John Deere oil is **also recommended**:

- **TORQ-GARD SUPREME®—SAE 5W-30.**

If the above recommended John Deere oils are not available, use a break-in engine oil meeting the following specification during the first 5 hours (maximum) of operation:

- SAE 5W-30—API Service Classification SE or higher.

IMPORTANT: After the break-in period, use the John Deere oil that is recommended for this engine.

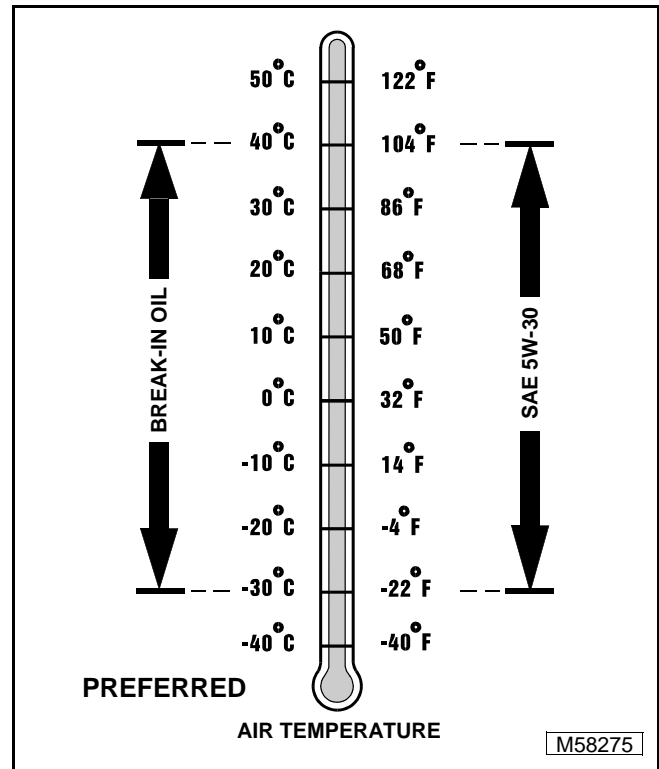

John Deere Dealers: You may want to cross-reference the following publications to recommend the proper oil for your customers:

- Module DX, ENOIL4 in JDS-G135;
- Section 530, Lubricants & Hydraulics, of the John Deere Merchandise Sales Guide;
- Lubrication Sales Manual PI7032.

BREAK-IN 4-CYCLE GASOLINE ENGINE OIL—EUROPE

IMPORTANT: ONLY use a quality break-in oil in rebuilt or remanufactured engines for the first 5 hours (maximum) of operation. DO NOT use oils with heavier viscosity weights than SAE 5W-30 or oils meeting CCMC Specification G5—these oils will not allow rebuilt or remanufactured engines to break-in properly.

The following John Deere oil is **PREFERRED**:

- **BREAK-IN ENGINE OIL.**

John Deere **BREAK-IN ENGINE OIL** is formulated with special additives for aluminum and cast iron type engines to allow the power cylinder components (pistons, rings, and liners as well) to “wear-in” while protecting other engine components, valve train and gears, from abnormal wear. Engine rebuild instructions should be followed closely to determine if special requirements are necessary.

John Deere **BREAK-IN ENGINE OIL** is also recommended for non-John Deere engines, both aluminum and cast iron types.

The following John Deere oil is **also recommended**:

- **TORQ-GARD SUPREME®—SAE 5W-30.**

If the above recommended John Deere oils are not available, use a break-in engine oil meeting the following specification during the first 5 hours (maximum) of operation:

- SAE 5W-30—CCMC Specification G4 or higher.

IMPORTANT: After the break-in period, use the John Deere oil that is specified for this engine.

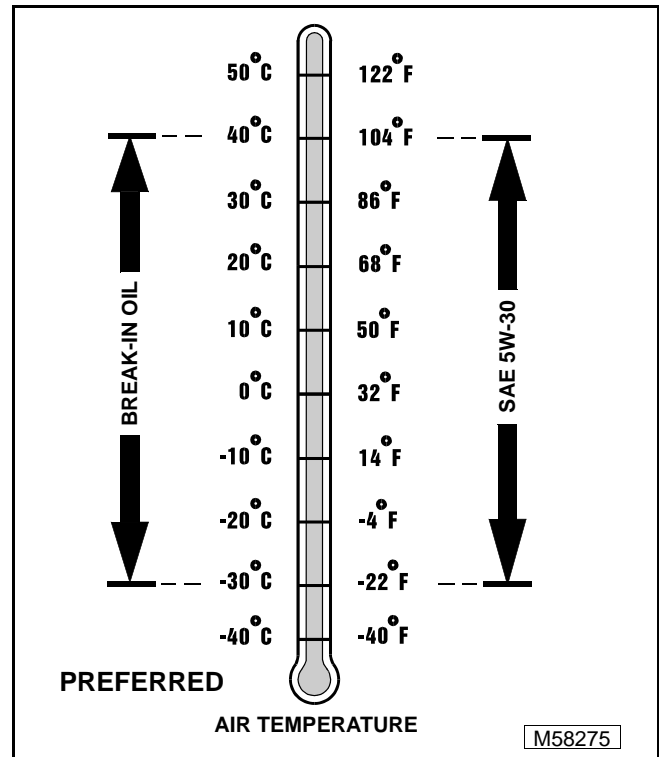

John Deere Dealers: You may want to cross-reference the following publications to recommend the proper oil for your customers:

- Module DX, ENOIL4 in JDS-G135;
- Section 530, Lubricants & Hydraulics, of the John Deere Merchandise Sales Guide.

HYDROSTATIC TRANSMISSION OIL —NORTH AMERICA

Use the appropriate oil viscosity based on these air temperature ranges. Operating outside of these recommended oil air temperature ranges may cause premature hydrostatic transmission failure.

IMPORTANT: ONLY use a quality SAE 10W-30 or SAE 5W-30 engine oil in this transmission. Mixing of these two viscosity grade oils is permitted. **DO NOT** use BIO-HY-GARD® in this transmission.

The following John Deere oils are **PREFERRED**:

- TURF-GARD®—SAE 10W-30;
- PLUS-4®—SAE 10W-30.
- TORQ-GARD SUPREME®—SAE 5W-30.

Other oils may be used if above recommended John Deere oils are not available, provided they meet one of the following specifications:

- API Service Classifications SG or higher.

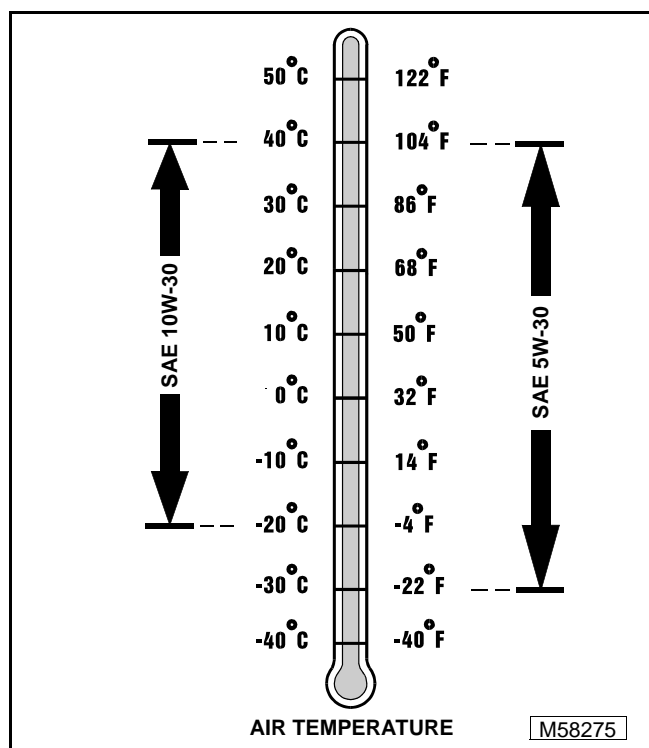

John Deere Dealers: You may want to cross-reference the following publications to recommend the proper oil for your customers:

- Module DX, ENOIL2 in JDS-G135;
- Section 530, Lubricants & Hydraulics, of the John Deere Merchandise Sales Guide;
- Lubrication Sales Manual PI7032.

HYDROSTATIC TRANSMISSION OIL—EUROPE

Use the appropriate oil viscosity based on these air temperature ranges. Operating outside of these recommended oil air temperature ranges may cause premature hydrostatic transmission failure.

IMPORTANT: ONLY use a quality SAE 10W-30 or SAE 5W-30 engine oil in this transmission. Mixing of these two viscosity grade oils is permitted. **DO NOT** use BIO-HY-GARD® in this transmission.

The following John Deere oils are **PREFERRED**:

- TORQ-GARD SUPREME®—SAE 10W-30;
- TORQ-GARD SUPREME®—SAE 5W-30.

Other oils may be used if above recommended John Deere oils are not available, provided they meet one of the following specifications:

- CCMC Specifications G4 or higher.

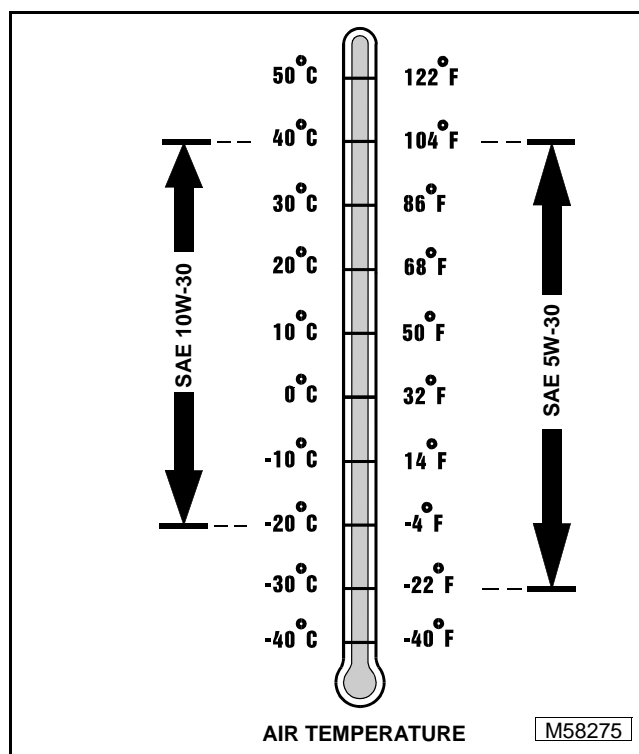

John Deere Dealers: You may want to cross-reference the following publications to recommend the proper oil for your customers:

- Module DX, ENOIL2 in JDS-G135;
- Section 530, Lubricants & Hydraulics, of the John Deere Merchandise Sales Guide.

GEAR TRANSMISSION GREASE—NORTH AMERICA

Use the following gear grease based on the air temperature range. Operating outside of the recommended grease air temperature range may cause premature gear transmission failure.

IMPORTANT: ONLY use a quality gear grease in this transmission. DO NOT mix any other greases in this transmission. DO NOT use any BIO-GREASE in this transmission.

The following John Deere gear grease is **PREFERRED**:

- **NON-CLAY HIGH-TEMPERATURE EP GREASE® —JDM J13E4, NLGI Grade 2.**

Other gear greases may be used if above recommended John Deere gear grease is not available, provided they meet one of the following specification:

- John Deere Standard JDM J13E4,
- NLGI Grade 2.

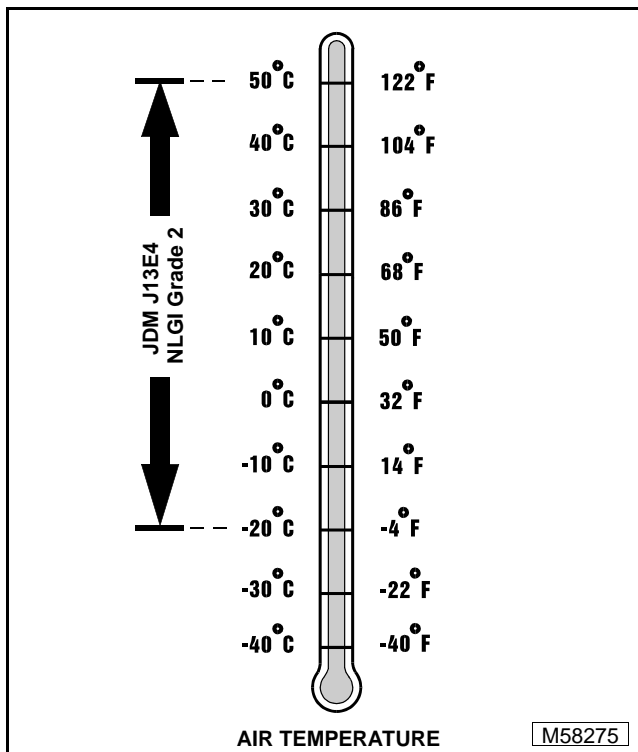

John Deere Dealers: You may want to cross-reference the following publications to recommend the proper grease for your customers:

- Module DX,GREA1 in JDS-G135;
- Section 530, Lubricants & Hydraulics, of the John Deere Merchandise Sales Guide;
- Lubrication Sales Manual PI7032.

GEAR TRANSMISSION GREASE—EUROPE

Use the following gear grease based on the air temperature range. Operating outside of the recommended grease air temperature range may cause premature gear transmission failure.

IMPORTANT: ONLY use a quality gear grease in this transmission. DO NOT mix any other greases in this transmission. DO NOT use any BIO-GREASE in this transmission.

The following John Deere gear grease is **PREFERRED**:

- **GREASE-GARD™—JDM J13E4, NLGI Grade 2.**

Other gear greases may be used if above recommended John Deere gear grease is not available, provided they meet the following specification:

- John Deere Standard JDM J13E4,
- NLGI Grade 2.

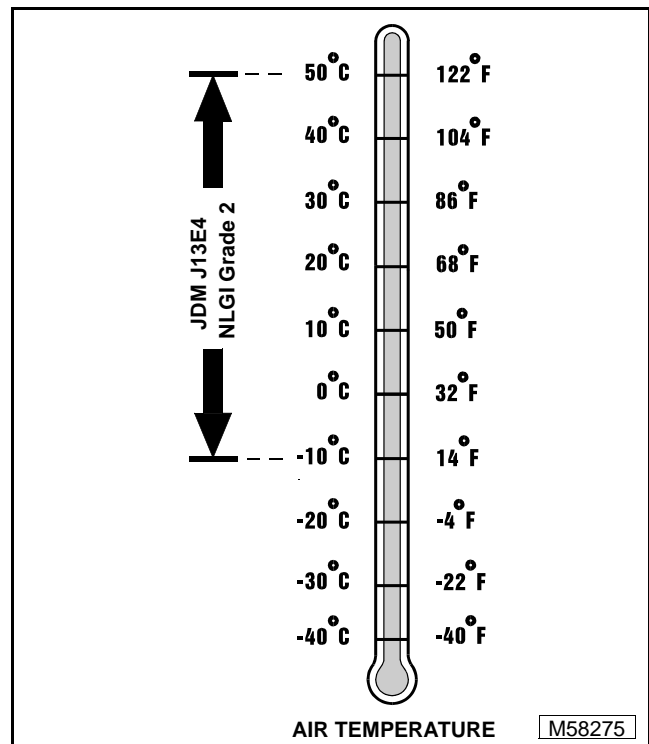

John Deere Dealers: You may want to cross-reference the following publications to recommend the proper grease for your customers:

- Module DX,GREA1 in JDS-G135;
- Section 530, Lubricants & Hydraulics, of the John Deere Merchandise Sales Guide.

GREASE—NORTH AMERICA

Use the following grease based on the air temperature range. Operating outside of the recommended grease air temperature range may cause premature failures.



IMPORTANT: ONLY use a quality grease in this application. DO NOT mix any other greases in this application. DO NOT use any BIO-GREASE in this application.

The following John Deere grease is **PREFERRED**:

- **NON-CLAY HIGH-TEMPERATURE EP GREASE®—JDM J13E4, NLGI Grade 2.**

Other greases may be used if above preferred John Deere grease is not available, provided they meet the following specification:

- John Deere Standard JDM J13E4, NLGI Grade 2.

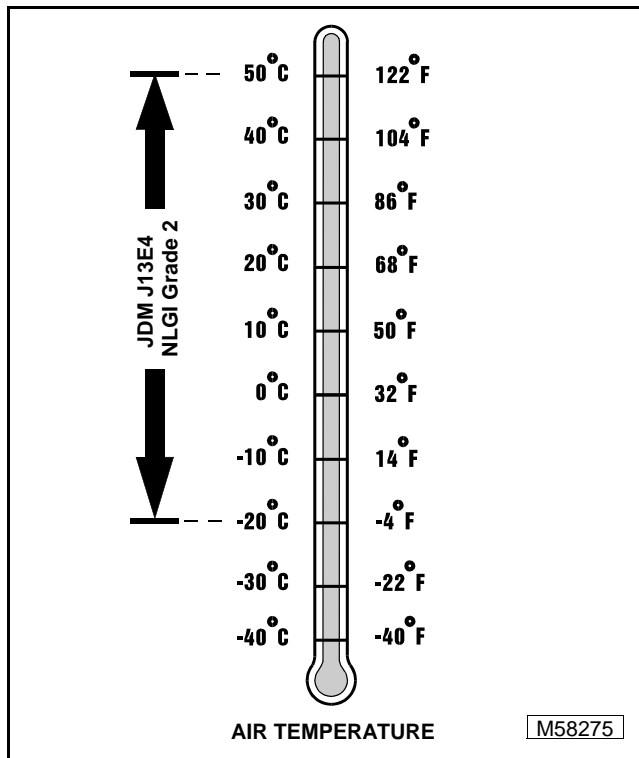

John Deere Dealers: You may want to cross-reference the following publications to recommend the proper grease for your customers:

- Module DX,GREA1 in JDS-G135;
- Section 530, Lubricants & Hydraulics, of the John Deere Merchandise Sales Guide;
- the Lubrication Sales Manual PI7032.

GREASE—EUROPE

Use the following grease based on the air temperature range. Operating outside of the recommended grease air temperature range may cause premature failures.

IMPORTANT: ONLY use a quality grease in this application. DO NOT mix any other greases in this application. DO NOT use any BIO-GREASE in this application.

The following John Deere grease is **PREFERRED**:

- **GREASE-GARD™—JDM J13E4, NLGI Grade 2.**

Other greases may be used if above preferred John Deere grease is not available, provided they meet the following specification:

- John Deere Standard JDM J13E4, NLGI Grade 2.

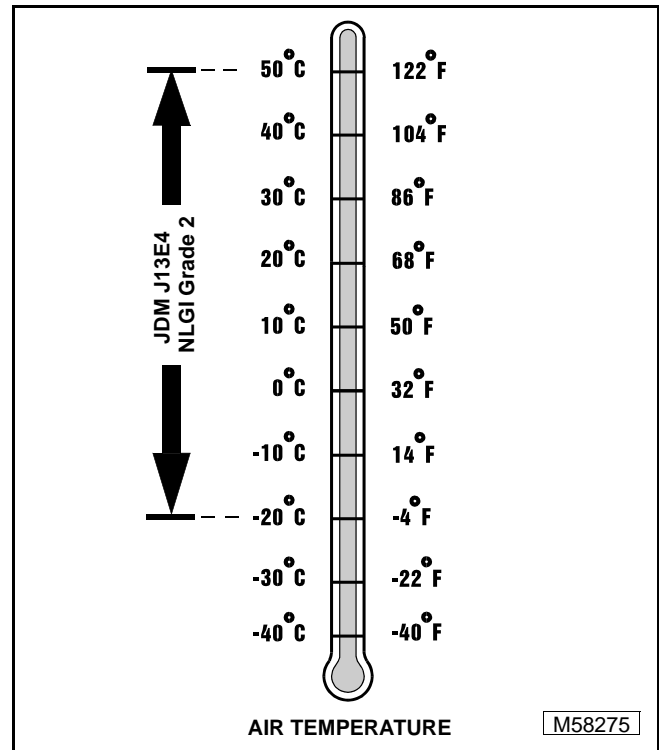

John Deere Dealers: You may want to cross-reference the following publications to recommend the proper grease for your customers:

- Module DX,GREA1 in JDS-G135;
- Section 530, Lubricants & Hydraulics, of the John Deere Merchandise Sales Guide.

ANTI-CORROSION GREASE—NORTH AMERICA

This anti-corrosion grease is formulated to provide the best protection against absorbing moisture, which is one of the major causes of corrosion. This grease is also superior in its resistance to separation and migration.

The following anti-corrosion grease is **PREFERRED**:

- DuBois MPG-2® Multi-Purpose Polymer Grease—M79292.

Other greases may be used if they meet or exceed the following specifications:

- John Deere Standard JDM J13A2, NLGI Grade 1.

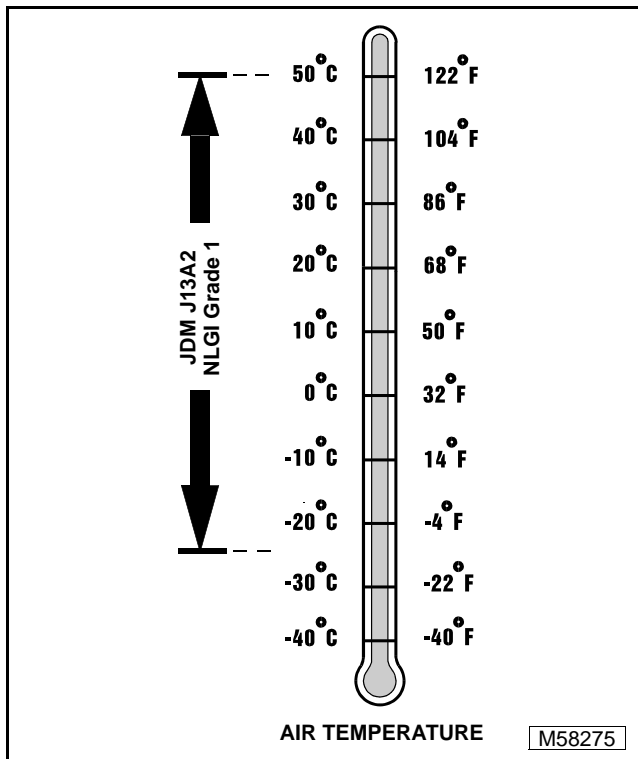

John Deere Dealers: You may want to cross-reference the following publications to recommend the proper grease for your customers:

- Module DX,GREA1 in JDS—G135;
- Section 530, Lubricants & Hydraulics, of the John Deere Merchandise Sales Guide;
- the Lubrication Sales Manual PI7032.

ANTI-CORROSION GREASE—EUROPE

This anti-corrosion grease is formulated to provide the best protection against absorbing moisture, which is one of the major causes of corrosion. This grease is also superior in its resistance to separation and migration.

The following anti-corrosion grease is **PREFERRED**:

- DuBois MPG-2® Multi-Purpose Polymer Grease—M79292.

Other greases may be used if they meet or exceed the following specifications:

- John Deere Standard JDM J13A2, NLGI Grade 1.

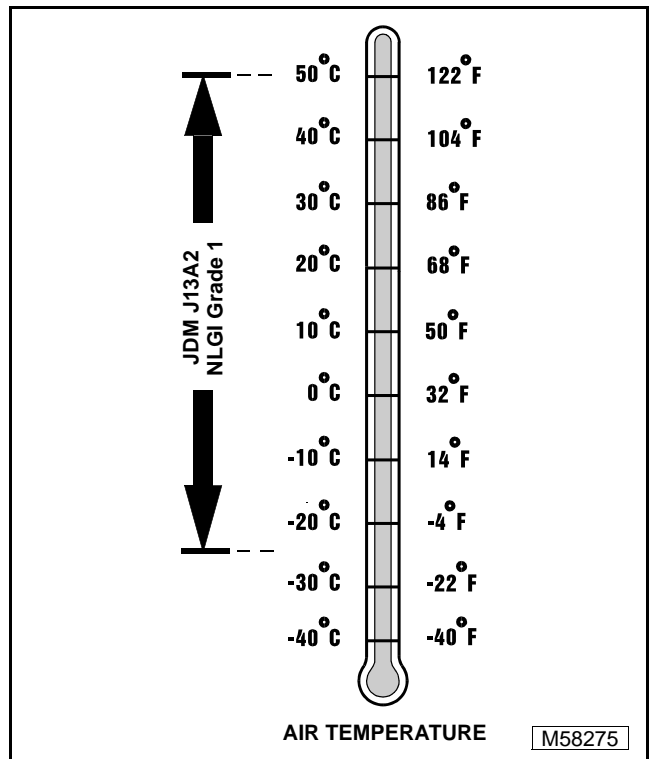

John Deere Dealers: You may want to cross-reference the following publications to recommend the proper grease for your customers:

- Module DX,GREA1 in JDS—G135;
- Section 530, Lubricants & Hydraulics, of the John Deere Merchandise Sales Guide.

ALTERNATIVE LUBRICANTS

Conditions in certain geographical areas outside the United States and Canada may require different lubricant recommendations than the ones printed in this technical manual or the operator's manual. Consult with your John Deere Dealer, or Sales Branch, to obtain the alternative lubricant recommendations.



IMPORTANT: Use of alternative lubricants could cause reduced life of the component.

If alternative lubricants are to be used, it is recommended that the factory fill be thoroughly removed before switching to any alternative lubricant.

SYNTHETIC LUBRICANTS

Synthetic lubricants may be used in John Deere equipment if they meet the applicable performance requirements (industry classification and/or military specification) as shown in this manual.

The recommended air temperature limits and service or lubricant change intervals should be maintained as shown in the operator's manual.

Avoid mixing different brands, grades, or types of oil. Oil manufacturers blend additives in their oils to meet certain specifications and performance requirements. Mixing different oils can interfere with the proper functioning of these additives and degrade lubricant performance.

LUBRICANT STORAGE

All machines operate at top efficiency only when clean lubricants are used. Use clean storage containers to handle all lubricants. Store them in an area protected from dust, moisture, and other contamination. Store drums on their sides. Make sure all containers are properly marked as to their contents. Dispose of all old, used containers and their contents properly.

MIXING OF LUBRICANTS

In general, avoid mixing different brands or types of lubricants. Manufacturers blend additives in their lubricants to meet certain specifications and performance requirements. Mixing different lubricants can interfere with the proper functioning of these additives and lubricant properties which will downgrade their intended specified performance.

OIL FILTERS

IMPORTANT: Filtration of oils is critical to proper lubrication performance. Always change filters regularly.

The following John Deere oil filters are PREFERRED:

- AUTOMOTIVE AND LIGHT TRUCK ENGINE OIL FILTERS.

Most John Deere filters contain pressure relief and anti-drainback valves for better engine protection.

Other oil filters may be used if above recommended John Deere oil filters are not available, provided they meet the following specification:

- ASTB Tested In Accordance With SAE J806.

John Deere Dealers: You may want to cross-reference the following publications to recommend the proper oil filter for your customers:

- Module DX,FILT in JDS-G135;
- Section 540, Lubricants & Hydraulics, of the John Deere Merchandise Sales Guide;
- Lawn & Grounds Care Tune-Up Guide PI672.

GASOLINE ENGINE COOLANT—NORTH AMERICA

The engine cooling system when filled with a proper dilution mixture of anti-freeze and deionized or distilled water provides year-round protection against corrosion, cylinder or liner pitting, and winter freeze protection down to -37°C (-34°F).

The following John Deere coolant is **PREFERRED**:

- **PRE-DILUTED DIESEL ENGINE ANTI-FREEZE/SUMMER COOLANT™ (TY16036).**

This coolant satisfies specifications for “Automobile and Light Duty Engine Service” and is safe for use in John Deere Lawn and Grounds Care/Golf and Turf Division equipment, including aluminum block gasoline engines and cooling systems.

The above preferred pre-diluted anti-freeze provides:

- adequate heat transfer
- corrosion-resistant chemicals for the cooling system
- compatibility with cooling system hose and seal material
- protection during extreme cold and extreme hot weather operations
- chemically pure water for better service life
- compliance with ASTM D4656 (JDM H24C2) specifications

If above preferred pre-diluted coolant is not available, the following John Deere concentrate is **recommended**:

- **DIESEL ENGINE ANTI-FREEZE/SUMMER COOLANT CONCENTRATE™ (TY16034).**

If either of above recommended engine coolants are available use any Automobile and Light Duty Engine Service ethylene glycol base coolant, meeting the following specification:

- ASTM D3306 (JDM H24C1).

Read container label completely before using and follow instructions as stated.

IMPORTANT: To prevent engine damage, **DO NOT** use pure anti-freeze or less than a 50% anti-freeze mixture in the cooling system. **DO NOT** mix or add any additives/conditioners to the cooling system in Lawn and Grounds Care/Golf and Turf Division equipment. Water used to dilute engine coolant concentrate must be of high quality—clean, clear, potable water (low in chloride and hardness—Table 1) is generally acceptable. **DO NOT** use salt water. Deionized or distilled water is ideal to use. Coolant that is not mixed to these specified levels and water purity can cause excessive scale, sludge deposits, and increased corrosion potential.



Water Quality

Property	Requirements
Total Solids, Maximum	340 ppm (20 grns/gal)
Total Hardness, Max.	170 ppm (10 grns/gal)
Chloride (as Cl), Max.	40 ppm (2.5 grns/gal)
Sulfate (as SO ₄), Max.	100 ppm (5.8 grns/gal)

Mix 50 percent anti-freeze concentrate with 50 percent distilled or deionized water. This mixture and the pre-diluted mixture (TY16036) will protect the cooling system down to -37°C(-34°F) and up to 108°C (226°F).

Certain geographical areas may require lower air temperature protection. See the label on your anti-freeze container or consult your John Deere dealer to obtain the latest information and recommendations.

GASOLINE ENGINE COOLANT DRAIN INTERVAL—NORTH AMERICA

When using **John Deere Pre-Diluted (TY16036)** Automobile and Light Duty Engine Service coolants, drain and flush the cooling system and refill with fresh coolant mixture every **36 months or 3,000 hours** of operation, whichever comes first.

When using **John Deere Concentrate (TY16034)** Automobile and Light Duty Engine Service coolants, drain and flush the cooling system and refill with fresh coolant mixture every **24 months or 2,000 hours** of operation, whichever comes first.

If above John Deere Automobile and Light Duty Engine Service coolants **are not** being used; drain, flush, and refill the cooling system according to instructions found on product container or in equipment operator’s manual or technical manual.

GASOLINE ENGINE COOLANT—EUROPE

The engine cooling system when filled with a proper dilution mixture of anti-freeze and deionized or distilled water provides year-round protection against corrosion, cylinder or liner pitting, and winter freeze protection down to -37°C (-34°F).

ONLY use a quality Automobile and Light Duty Engine Service **ethylene glycol base coolant**, meeting the following specification:

- ASTM D3306 (JDM H24C1).

Read container label completely before using and follow instructions as stated.

IMPORTANT: To prevent engine damage, **DO NOT** use pure anti-freeze or less than a 50% anti-freeze mixture in the cooling system. **DO NOT** mix or add any additives/conditioners to the cooling system in Lawn and Grounds Care/Golf and Turf Division equipment. Water used to dilute engine coolant concentrate must be of high quality—clean, clear, potable water (low in chloride and hardness—Table 1) is generally acceptable. **DO NOT** use salt water. Deionized or distilled water is best to use. Coolant that is not mixed to these specified levels and water purity can cause excessive scale, sludge deposits, and increased corrosion potential.

Water Quality

Property	Requirements
Total Solids, Maximum	340 ppm (20 grns/gal)
Total Hardness, Max.	170 ppm (10 grns/gal)
Chloride (as Cl), Max.	40 ppm (2.5 grns/gal)
Sulfate (as SO_4), Max.	100 ppm (5.8 grns/gal)

Mix 50 percent anti-freeze concentrate with 50 percent distilled or deionized water. This mixture will protect the cooling system down to -37°C (-34°F) and up to 108°C (226°F).

Certain geographical areas may require lower air temperature protection. See the label on your anti-freeze container or consult your John Deere dealer to obtain the latest information and recommendations.

GASOLINE ENGINE COOLANT DRAIN INTERVAL—EUROPE

If a quality Automobile and Light Duty Engine Service **ethylene glycol base coolant** is being used, drain and flush the cooling system and refill with fresh coolant mixture every **24 months or 2,000 hours** of operation, whichever comes first.

If a quality Automobile and Light Duty Engine Service coolant **is not** being used; drain, flush, and refill the cooling system according to instructions found on product container or in equipment operator's manual or technical manual.

SERIAL NUMBER LOCATION

When ordering parts or submitting a warranty claim, it is IMPORTANT that the machine product identification number and component serial numbers are included.

The location of the machine identification number and component serial numbers are shown.

MACHINE IDENTIFICATION NUMBER

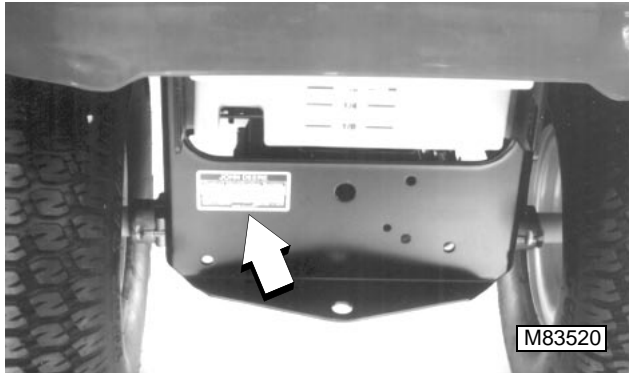

ENGINE SERIAL NUMBER—LX178 AND LX188

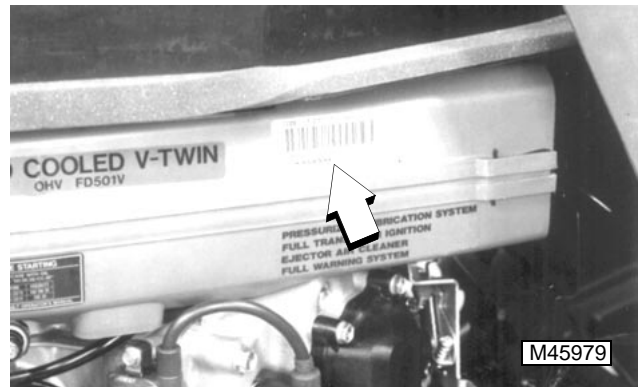

CARBURETOR SERIAL NUMBER—LX172, LX176 AND LX186

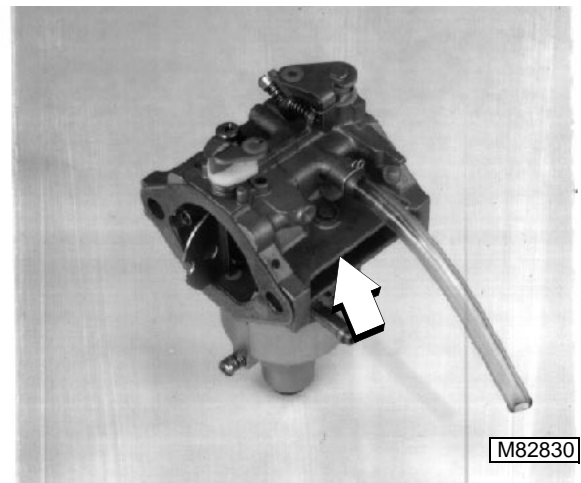

ENGINE SERIAL NUMBER—LX172, LX176 AND LX186



CARBURETOR PART NUMBER — LX173 (ONLY)



ENGINE SERIAL NUMBER—LX173

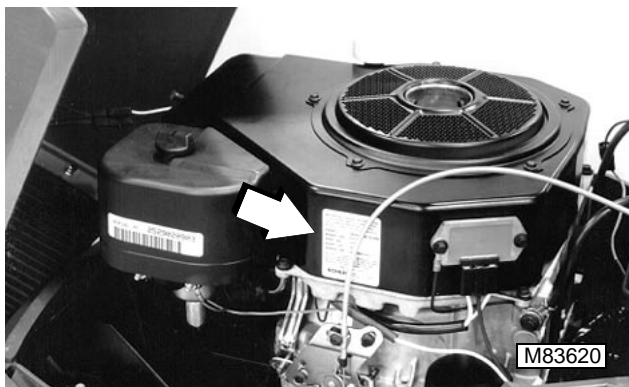

**CARBURETOR SERIAL NUMBER—
LX178 AND LX188**

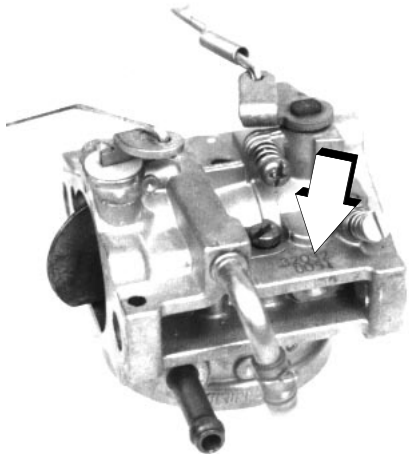

M53957

**MOWER DECK SERIAL NUMBER
LOCATION**

38 and 48-Inch Mower Decks

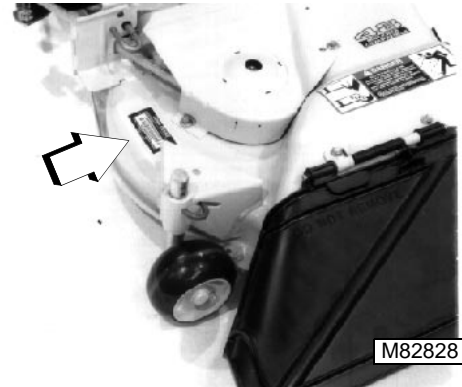

M82828

**GEAR TRANSAXLE SERIAL
NUMBER—LX172 AND LX173**

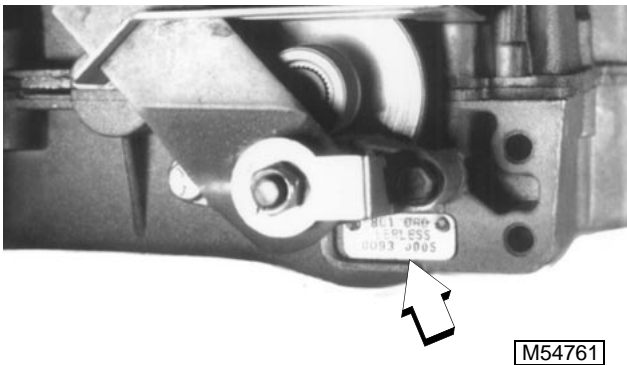

M54761

44-Inch Rear Discharge Mower Deck

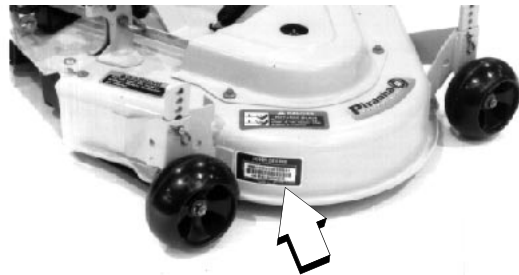

M82827

**HYDROSTATIC TRANSAXLE SERIAL
NUMBER—LX176, LX178, LX186
AND LX188**

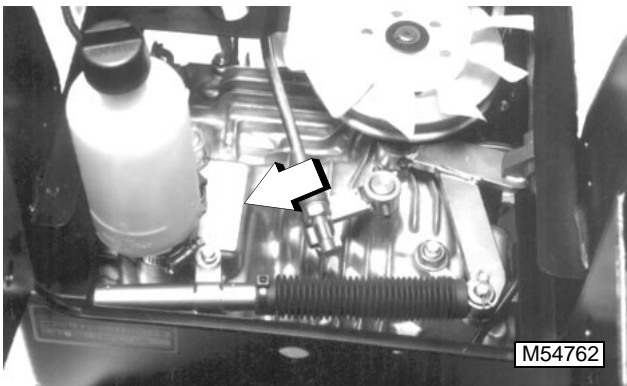

M54762

CONTENTS

	Page
ENGINE—KAWASAKI FC420V(LX172/LX176) / FC540V(LX186)	
SPECIFICATIONS	
ENGINE DESIGNATION	3-7
TEST AND ADJUSTMENT SPECIFICATIONS	3-7
REPAIR SPECIFICATIONS	3-7
SPECIAL OR ESSENTIAL TOOLS	3-12
OTHER MATERIALS	3-13
SERVICE PARTS KITS	3-13
COMPONENT LOCATION	
EXTERNAL ENGINE COMPONENTS	3-14
INTERNAL ENGINE COMPONENTS	3-15
OIL PUMP, BREATHER AND COMPRESSION RELEASE COMPONENTS	3-16
FUEL/AIR SYSTEM COMPONENTS	3-17
THEORY OF OPERATION	
LUBRICATION SYSTEM OPERATION	3-18
COOLING SYSTEM OPERATION	3-20
TROUBLESHOOTING	
TRUBLESHOOTING CHART	3-22
ENGINE TROUBLESHOOTING GUIDE	3-24
STARTER MOTOR TROUBLESHOOTING GUIDE	3-28
TESTS AND ADJUSTMENTS	
THROTTLE CABLE TEST AND ADJUSTMENT	3-29
CHOKE PLATE TEST AND ADJUSTMENT	3-29
GOVERNOR ADJUSTMENT	3-30
FAST IDLE SPEED ADJUSTMENT	3-31
SLOW IDLE SPEED ADJUSTMENT—NON CARB/EPA ENGINES	3-32
SLOW IDLE SPEED ADJUSTMENT—CARB/EPA ENGINES	3-32
CYLINDER COMPRESSION PRESSURE TEST	3-34
VALVE CLEARANCE TEST AND ADJUSTMENT	3-35
AUTOMATIC COMPRESSION RELEASE (ACR) TEST	3-35
CRANKCASE VACUUM TEST	3-36
ENGINE OIL PRESSURE TEST	3-37
FUEL PUMP TESTS	3-37
SPARK TEST	3-38
SPARK PLUG GAP ADJUSTMENT	3-39
MAGNETO IGNITION COIL RESISTANCE TEST	3-39
IGNITOR MODULE TEST	3-40
MAGNETO IGNITION COIL WITH IGNITION MODULE RESISTANCE TEST	3-40
REPAIR	
FUEL TANK	3-41
THROTTLE CONTROL LEVER AND CABLE	3-41
ENGINE	3-42
MUFFLER	3-43





	Page
REPAIR, continued	
AIR CLEANER	3-43
CARBURETOR	
Removal/Installation.	3-44
Disassembly/Assembly	3-44
Clean/Inspect/Rebuild	3-47
FUEL PUMP	3-47
BREATHER	3-47
BLOWER HOUSING	
Inspection/Replacement.	3-48
Flywheel Screen Adjustment	3-48
FLYWHEEL.	3-48
ROCKER ARM ASSEMBLY	
Removal/Installation.	3-49
Inspection.	3-49
CYLINDER HEAD AND VALVES	
Removal/Installation.	3-49
Disassembly/Assembly	3-50
Inspection.	3-51
Valve Guide Replacement	3-52
ANALYZE VALVES	3-53
RECONDITION VALVE SEATS	3-54
LAP VALVES	3-54
CRANKCASE COVER	3-54
PISTON AND CONNECTING ROD	
Removal	3-55
Installation	3-55
Disassembly.	3-55
Assembly	3-56
Inspection.	3-56
Check Piston Ring End Gap	3-58
ANALYZE PISTON RING WEAR	3-58
ANALYZE PISTON WEAR	3-60
CAMSHAFT AND TAPPETS	
Removal	3-61
Installation	3-61
Inspection.	3-62
RECIPROCATING BALANCER	
Removal/Installation.	3-63
Disassembly/Assembly	3-63
Inspection.	3-64
Bearing Replacement.	3-64
crankshaft end play test	3-65
CRANKSHAFT AND MAIN BEARINGS	
Removal/Installation.	3-65
Inspection.	3-65
End Play Adjustment	3-66

	Page
REPAIR, continued	
CRANKSHAFT OIL SEALS	3-67
ANALYZE CRANKSHAFT AND CONNECTING ROD WEAR	3-67
CYLINDER BLOCK	
Inspection	3-68
Deglaze Cylinder Bore	3-68
Rebore Cylinder Block	3-68
OIL PUMP	
Disassembly/Assembly	3-69
Inspection	3-70
OIL FILTER MANIFOLD	3-71
GOVERNOR	3-71
GOVERNOR SHAFT	3-72
STATOR	3-72
MAGNETO IGNITION COIL	
Removal/Installation	3-72
Air Gap Adjustment	3-73
IGNITOR MODULE	3-73
MAGNETO IGNITION COIL WITH IGNITOR MODULE	
Removal/Installation	3-73
Air Gap Adjustment	3-73
STARTER	
Removal/Installation	3-74
Analyze Condition	3-74
Starter No-Load Amperage Draw and RPM Bench Tests	3-74
Disassembly/Assembly	3-75
Exploded View	3-75
Inspection/Test	3-76



ENGINE—KAWASAKI FD440V(LX178) / FD501V(LX188)

SPECIFICATIONS

ENGINE DESIGNATION 3-79
 TEST AND ADJUSTMENT SPECIFICATIONS 3-79
 REPAIR SPECIFICATIONS 3-80
 SPECIAL OR ESSENTIAL TOOLS 3-82
 OTHER MATERIALS 3-83
 SERVICE PARTS KITS 3-83

COMPONENT LOCATION

EXTERIOR ENGINE COMPONENTS 3-85
 INTERNAL ENGINE COMPONENTS 3-87
 FUEL/AIR SYSTEM COMPONENTS 3-89

THEORY OF OPERATION

LUBRICATION SYSTEM OPERATION 3-90
 COOLING SYSTEM OPERATION 3-92

TROUBLESHOOTING

TROUBLESHOOTING CHART 3-94
 ENGINE TROUBLESHOOTING GUIDE 3-96
 STARTER MOTOR TROUBLESHOOTING GUIDE 3-100

TESTS AND ADJUSTMENTS

THROTTLE CABLE TEST AND ADJUSTMENT 3-101
 CHOKE PLATE TEST AND ADJUSTMENT 3-101
 GOVERNOR ADJUSTMENT 3-102
 FAST IDLE SPEED ADJUSTMENT 3-103
 SLOW IDLE SPEED ADJUSTMENT NON CARB/EPA ENGINES 3-103
 SLOW IDLE SPEED ADJUSTMENT CARB/EPA ENGINES 3-104
 CYLINDER COMPRESSION PRESSURE TEST 3-105
 VALVE CLEARANCE TEST AND ADJUSTMENT 3-106
 CRANKCASE VACUUM TEST 3-107
 ENGINE OIL PRESSURE TEST 3-108
 FUEL PUMP TEST 3-108
 SPARK TEST 3-110
 SPARK PLUG GAP ADJUSTMENT 3-110
 COOLING SYSTEM PRESSURE TEST 3-110
 RADIATOR CAP PRESSURE TEST 3-111

REPAIR

FUEL TANK 3-112
 THROTTLE CONTROL LEVER AND CABLE 3-112
 ENGINE 3-112
 MUFFLER 3-114
 AIR CLEANER 3-114



	Page
REPAIR, continued	
CARBURETOR	
Removal/Installation	3-115
Disassembly/Assembly	3-115
Clean/Inspect/Rebuild	3-118
Float Level Adjustment	3-118
INTAKE MANIFOLD	
Removal/Installation	3-118
Inspection	3-119
FUEL PUMP	
Removal/Installation	3-119
Inspection	3-119
RADIATOR	
Removal/Installation	3-119
Inspection	3-120
COOLING FAN	3-121
COOLING AIR DUCT	3-121
THERMOSTAT	
Removal/Installation	3-121
Opening Test	3-122
COOLANT PUMP	
Removal/Installation	3-122
Disassembly/Inspection/Assembly	3-122
OVERFLOW RESERVOIR	3-123
FLYWHEEL	3-123
ROCKER ARM ASSEMBLY	
Removal/Installation	3-124
Inspection	3-124
CYLINDER HEAD AND VALVES	
Removal/Installation	3-124
Disassembly/Assembly	3-125
Inspection/Replacement	3-125
ANALYZE VALVES	3-127
RECONDITION VALVE SEATS	3-128
LAP VALVES	3-128
CRANKCASE COVER	3-129
PISTON AND CONNECTING ROD	
Removal	3-129
Installation	3-129
Disassembly	3-130
Assembly	3-131
Inspection	3-131
Check Piston Ring End Gap	3-133
ANALYZE PISTON RING WEAR	3-133
ANALYZE PISTON WEAR	3-134



REPAIR, continued

CAMSHAFT AND TAPPETS

Removal/Installation 3-135

Inspection 3-136

CRANKSHAFT AND MAIN BEARINGS

Removal/Installation 3-136

Inspection 3-137

CRANKSHAFT OIL SEALS 3-137

ANALYZE CRANKSHAFT AND CONNECTING ROD WEAR 3-137

CYLINDER BLOCK

Inspection 3-138

Deglaze Cylinder Bore 3-138

Rebore Cylinder Block 3-138

OIL PUMP

Disassembly/Assembly 3-139

Inspection 3-140

BREATHER 3-141

GOVERNOR 3-141

GOVERNOR SHAFT 3-142

GOVERNOR SHAFT SEAL 3-142

STATOR 3-142

PULSER COILS 3-142

IGNITION COILS 3-143

IGNITION MODULE 3-143

STARTER

Removal/Installation 3-143

Analyze Condition 3-143

No-Load Amperage Draw and RPM Bench Tests 3-144

Disassembly/Assembly 3-145

Inspection/Test 3-146



SPECIFICATIONS

ENGINE DESIGNATION

NOTE: LX172 and LX176 tractors use engine model number FC420V, LX186 tractor uses engine model number FC540V.

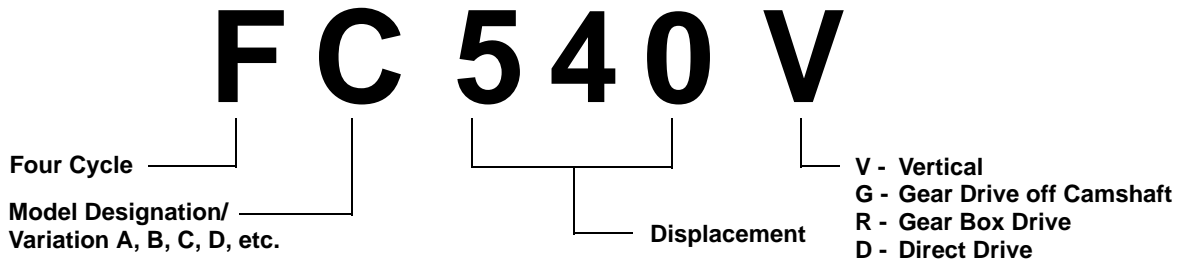

TEST AND ADJUSTMENT SPECIFICATIONS

SLOW Idle

Carburetor SLOW Idle Stop Screw Setting	1450 ±75 rpm
Throttle Control Arm	
SLOW Idle Stop Screw Setting	1550 ±75 rpm
FAST Idle	3350 ±100 rpm
Cylinder Compression Pressure (Minimum)	483 kPa (71 psi)
Valve Clearance (Cold)	0.15 mm (0.006 in.)
Jam Nut Torque	20 N•m (180 lb-in.)
Valve Cover Cap Screw Torque	6 N•m (53 lb-in.)
Exhaust Valve ACR Movement (Minimum)	0.25 mm (0.010 in.)
Crankcase Vacuum (Minimum)	15 cm (6 in.) of water movement
Engine Oil Pressure (Minimum)	
FAST Idle (3350 ±100 rpm)	240 kPa (35 psi)
SLOW Idle (1550 ±75 rpm)	20.68 kPa (3 psi)
Fuel Pump Pressure (Minimum)	6.12 kPa (0.90 psi)
Fuel Pump Flow (Minimum)	
FC420V	55 mL/15 seconds (1.8 oz/15 seconds)
FC540V	65 mL/15 seconds (2.2 oz/15 seconds)
Crankshaft End Play	0.09—0.22 mm (0.004—0.009 in.)
Spark Plug Gap	0.76 mm (0.030 in.)
Spark Plug Torque	20 N•m (177 lb-in.)

REPAIR SPECIFICATIONS

Rock Arm Assembly

Shaft O.D. (Minimum)	12.94 mm (0.509 in.)
Bearing I.D. (Maximum)	13.07 mm (0.515 in.)
Push Rod Bend (Maximum)	0.30 mm (0.012 in.)

REPAIR SPECIFICATIONS (Continued)

Cylinder Head and Valves

Rocker Arm Cap Screw Torque	10 N•m (89 lb-in.)
Valve Adjustment Screw Jam Nut Torque.	20 N•m (180 lb-in.)
Valve Cover Cap Screw Torque	6 N•m (53 lb-in.)
Cap Screw Torque in Sequence (Lubricated) at 7 N•m (62 lb-in.) Increments	
Initial Torque	32 N•m (288 lb-in.)
Final Torque	52 N•m (456 lb-in.)
Spark Plug Torque	20 N•m (177 lb-in.)
Cylinder Head Distortion (Maximum)	0.05 mm (0.002 in.)
Valve Guide I.D. (Maximum)	
FC420V	7.015 mm (0.2762 in.)
FC540V	7.07 mm (0.2780 in.)
Valve Seating Surface	1.10—1.46 mm (0.043—0.057 in.)
Valve Spring Free Length (Minimum)	
Early Model	37.50 mm (1.476 in.)
Late Model.	35.50 mm (1.398 in.)
Valve Margin (Minimum).	0.60 mm (0.024 in.)
Valve Stem Bend (Maximum)	0.03 mm (0.001 in.)
Valve Guide Installation Depth	
FC420V	12 ±0.1 mm (0.472 ±0.004 in.)
FC540V	9.5 ±0.1 mm (0.370 ±0.004 in.)
Finished Valve Guide I.D. (Reamed)	7.00—7.02 mm (0.275—0.276 in.)
Valve Seat and Face Angle	45°
Valve Narrow Angle	30°
Breather Air Gap	1—2 mm (0.040—0.080 in.)
Crankcase Cover	
Oil Capacity (w/Filter) FC420V	1.6 L (3.4 U.S. pt)
Oil Capacity (w/Filter) FC540V	1.9 L (4.0 U.S. pt)
Mounting Cap Screw Torque	26 N•m (230 lb-in.)
Piston Assembly	
Piston Ring Groove Side Clearance (Maximum)	
Top Ring	0.17 mm (0.007 in.)
Second Ring	0.15 mm (0.006 in.)
Oil Ring	0.20 mm (0.008 in.)
Pin O.D. (Minimum)	
Early Model	21.98 mm (0.865 in.)
Late Model.	18.975 mm (0.747 in.)
Pin Bore I.D. (Maximum)	
Early Model	22.04 mm (0.868 in.)
Late Model.	19.042 mm (0.7497 in.)
Piston O.D.	
Standard Piston.	88.83—88.864 mm (3.4885—3.4984 in.)
Oversize Piston 0.50 mm (0.020 in.)	89.330—89.364 mm (3.517—3.518 in.)
Cylinder Bore I.D.	
Standard Size Bore	
Standard.	88.98—89.00 mm (3.5031—3.5039 in.)
Wear Limit (Maximum).	89.076 mm (3.5069 in.)
Oversize Bore—0.50 mm (0.020 in.)	
Standard.	89.48—89.50 mm (3.5228—3.5236 in.)
Wear Limit (Maximum).	89.576 mm (3.5266 in.)



REPAIR SPECIFICATIONS (Continued)

Piston Assembly (Continued)

Piston-To-Cylinder Bore Clearance 0.011—0.151 mm (0.0043—0.0059 in.)

Connecting Rod

Connecting Rod Cap Screw Torque 20 N•m (177 lb-in.)

Crankshaft Bearing I.D. (Maximum)

Standard 41.07 mm (1.617 in.)

Undersized 40.56 mm (1.597 in.)

Piston Pin Bearing I.D. (Maximum)

Early Models 22.06 mm (0.869 in.)

Late Models 19.051 mm (0.750 in.)

Piston Rings

Ring Thickness—Top and Second Rings (Minimum) 1.94 mm (0.076 in.)

Ring End Gap (Minimum) 0.18 mm (0.007 in.)

Ring End Gap (Maximum)

Compression Rings—Top and Second

Early Model 0.90 mm (0.035 in.)

Late Model 1.50 mm (0.059 in.)

Oil Ring Side Rails 1.30 mm (0.051 in.)

Camshaft

End Journal O.D.—Cylinder Block (Minimum)

FC420V 19.912 mm (0.7839 in.)

FC540V 20.912 mm (0.8233 in.)

End Journal O.D.—Crankcase Cover (Minimum)

FC420V 20.912 mm (0.8233 in.)

FC540V 20.912 mm (0.8233 in.)

Lobe Height (Minimum)

FC420V 36.75 mm (1.446 in.)

FC540V 37.10 mm (1.461 in.)

Bearing I.D.—Cylinder Block (Maximum)

FC420V 20.076 mm (0.7904 in.)

FC540V 21.076 mm (0.8298 in.)

Bearing I.D.—Crankcase Cover (Maximum)

FC420V 21.076 mm (0.8298 in.)

FC540V 21.076 mm (0.8298 in.)

ACR Tappet Lift (Minimum) 0.6 mm (0.024 in.)

ACR Disengagement 600–900 rpm

Reciprocating Balancer

Support Shaft Nut Torque 7 N•m (65 lb-in.)

Link Rod

Journal O.D.—On Crankshaft (Minimum)

FC420V 53.950 mm (2.1240 in.)

FC540V 57.941 mm (2.2811 in.)

Small End I.D. (Maximum) 12.601 mm (0.4961 in.)

Large End I.D. (Maximum)

FC420V 54.121 mm (2.1307 in.)

FC540V 58.153 mm (2.2895 in.)

Bearing Installation Depth Below Surface (Both Ends) 1.0 mm (0.0394 in.)

Balancer Weight

Bearing I.D. (Maximum) 26.097 mm (1.0274 in.)

Bearing Installation Depth (Below Surface) 0.50 mm (0.0197 in.)

Support Shaft

Shaft O.D. (Minimum) 25.927 (1.0208 in.)



REPAIR SPECIFICATIONS (Continued)

Crankshaft

Total Indicated Runout (TIR)	0.05 mm (0.002 in.)
Main Bearing Journal O.D.—Crankcase Cover Side (Minimum)	
FC420V	34.919 mm (1.3747 in.)
FC540V	37.904 mm (1.4923 in.)
Main Bearing Journal O.D.—Cylinder Block Side (Minimum)	
Both Engines	34.945 mm (1.3757 in.)
Connecting Rod Journal O.D. (Minimum)	
Standard	40.928 mm (1.6113 in.)
Undersized	40.47—40.48 mm (1.5932—1.5937 in.)
Crankcase Cover Crankshaft Bearing I.D. (Maximum)	
FC420V	35.069 mm (1.3807 in.)
FC540V	38.056 mm (1.4983 in.)

Oil Seal Installation Depth

Both Sides/Both Engines	flush with surface
-----------------------------------	--------------------

Oil Pump

Rotor Shaft O.D. (Minimum)

FC420V (Large O.D.)	12.627 mm (0.4971 in.)
FC420V (Small O.D.)	7.935 mm (0.3125 in.)
FC540V	12.627 mm (0.4971 in.)

Rotor Shaft Bearing I.D. (Maximum)

FC420V (Oil Pump Cover)	12.76 mm (0.5024 in.)
FC420V (Crankcase Cover)	8.07 mm (0.3177 in.)
FC540V	12.76 mm (0.5023 in.)

Outer Rotor

FC420V

Minimum Thickness	11.92 mm (0.4692 in.)
Minimum O.D.	28.95 mm (1.1397 in.)

FC540V

Minimum Thickness	9.92 mm (0.3905 in.)
Minimum O.D.	40.47 mm (1.5933 in.)

Outer Rotor Bearing Housing

FC420V

Maximum Depth	12.14 mm (0.4779 in.)
Maximum I.D.	29.20 mm (1.1496 in.)

FC540V

Maximum Depth	10.17 mm (0.4003 in.)
Maximum I.D.	40.77 mm (1.6051 in.)

Relief Valve Spring Free Length (Minimum)	19.00 mm (0.7480 in.)
---	-----------------------

Governor

Governor Mounting Shaft Height	32.2—32.8 mm (1.267—1.291 in.)
--	--------------------------------

Governor Lever Nut Torque	7.8 N•m (69 lb-in.)
-------------------------------------	---------------------

Engine Mounting Cap Screw Torque	34 N•m (300 lb-in.)
--	---------------------

Blower Housing To Flywheel Screen Gap (Minimum)	1.5 mm (0.059 in.)
---	--------------------

Flywheel Screen To Cooling Fan Cap Screw Torque	6 N•m (53 lb-in.)
---	-------------------

Cooling Fan To Flywheel Cap Screw Torque	10 N•m (89 lb-in.)
--	--------------------

Flywheel Mounting Nut Torque

FC420V	137 N•m (101 lb-ft)
------------------	---------------------

FC540V	172 N•m (127 lb-ft)
------------------	---------------------

Oil Drain Plug Torque	23 N•m (200 lb-in.)
---------------------------------	---------------------



REPAIR SPECIFICATIONS (Continued)

Stator

Cap Screw Torque 6 N•m (53 lb-in.)

Ignitor Module

FC420V-DS15 (FC420V —FC420VB50632)

FC540V-DS15 (FC540V —FC540VA00384)

No Specifications. replace with known good ignitor module

Magneto Ignition Coil

FC420V-DS10 (FC420V —FC420VB50632)

FC540V-DS15 (FC540V —FC540VA00384)

Resistance Between Primary Lead and Core 0.48—0.72 ohms

Resistance Between Plug Cap and Core 10.9—16.3 K ohms

Air Gap 0.30 mm (0.012 in.)

Cap Screw Torque. 6 N•m (53 lb-in.)

Magneto Ignition Coil With Ignitor Module

FC420V-DS10 (FC420VB50633—)

FC540V-DS15 (FC540VA00385—)

Resistance Between Primary Lead and Core 0.48—0.72 ohms

Resistance Between Plug Cap and Core 8.7—13.1 K ohms

Air Gap 0.30 mm (0.012 in.)

Cap Screw Torque. 6 N•m (53 lb-in.)

Starter

Maximum Amperage (No Load) 50 amps at 6000 rpm

Minimum Starter Brush Length

FC420V 6 mm (0.240 in.)

FC540V 10.5 mm (0.413 in.)

Starter-To-Engine Mounting Cap Screw Torque 16 N•m (140 lb-in.)



SPECIAL OR ESSENTIAL TOOLS

NOTE: Order tools according to information given in the U.S. SERVICEGARD™ Catalog or in the European Microfiche Tool Catalog (MTC).



JT07270 Digital Pulse Tachometer

Used to check SLOW and FAST idle speeds and starter performance.

JDM59 Compression Gauge

Used to check engine compression.

JT05697 Manometer Kit

Contains #5 plug and the following:

JT05703 Barb Fitting

Used to connect U-tube manometer to engine for Crankcase Vacuum Test.

JT05699 Line

Used to connect U-tube manometer to engine for Crankcase Vacuum Test.

JT05698 U-Tube Manometer

Used to check crankshaft vacuum.

JT03503 Crankcase Vacuum Test Kit

Used to check crankcase vacuum.

JT05698 90° Elbow Fitting

Used to connect pressure gauge to engine when performing Engine Oil Pressure Test.

JT03344 Pressure Gauge Assembly

Used to read engine oil pressure when performing Engine Oil Pressure Test.

JT03017 Hose Assembly

Used to connect pressure gauge to engine when performing Engine Oil Pressure Test.

JDG356 Pressure Gauge

Used to check fuel pump performance.

D-05351ST Spark Tester

Used to check overall condition of ignition system.

JDM70 Valve Spring Compressor

Used to remove and install valve springs.

JDG504 Valve Guide Driver Tool

Used to replace valve guide bushings.

JT05712 Current Gun

Used to check starter performance.

OTHER MATERIALS

Number	Name	Use
M79292	MPG-2 [®] Multipurpose Polymer Grease	Apply to engine crankshaft.
	SCOTCH-BRITE [®] Abrasive	
	Sheets/Pads	Clean cylinder head.
	Valve Guide Cleaner	Clean valve guides.
	Stanisol (or Kerosene)	Finish ream valve guides.
	Prussian Blue Compound	Check valve seat contact.
	Lithium Base Grease	Pack oil seals.
	Zinc Oxide/Wood Alcohol	Check block for cracks.
	Mineral Spirits	Clean armature.
<p>LOCTITE[®] PRODUCTS U.S./ Canadian/ LOCTITE No.</p>		
TY9375/TY9480/592	Pipe Sealant with TEFLON [®]	Apply to threads of oil pressure switch.



SERVICE PARTS KITS

The following kits are available through your parts catalog:

- Fuel Pump Gasket Kit
- Carburetor
- Gasket Kit
- Vent Kit
- Jet Kit
- Choke Shaft Kit
- Throttle Shaft Kit
- Breather Valve Kit
- Air Cleaner Assembly
- Blower Housing Engine Cover Kit
- Flywheel Screen and Spacer Kit
- Dipstick Tube Kit
- Rocker Arm and Shaft Kit
- Intake Valve Kit
- Exhaust Valve Kit
- Camshaft and Tappet Kit
- Camshaft Axial Play Shim Kit
- Piston Ring Kit
- Oversized Piston
- Oversized Piston Ring Kit
- Undersized Connecting Rod
- Crankshaft End Play Shim Kit
- Cylinder Block
- Overhaul Gasket Kit
- Short Block Kit
- Oil Pump Kit
- Governor and Shaft Kit

MPG-2[®] is a registered trademark of DuBois USA.
LOCTITE[®] is a registered trademark of the Loctite Corp.
SCOTCH-BRITE[®] is a registered trademark of the 3M Co.

COMPONENT LOCATION

EXTERNAL ENGINE COMPONENTS

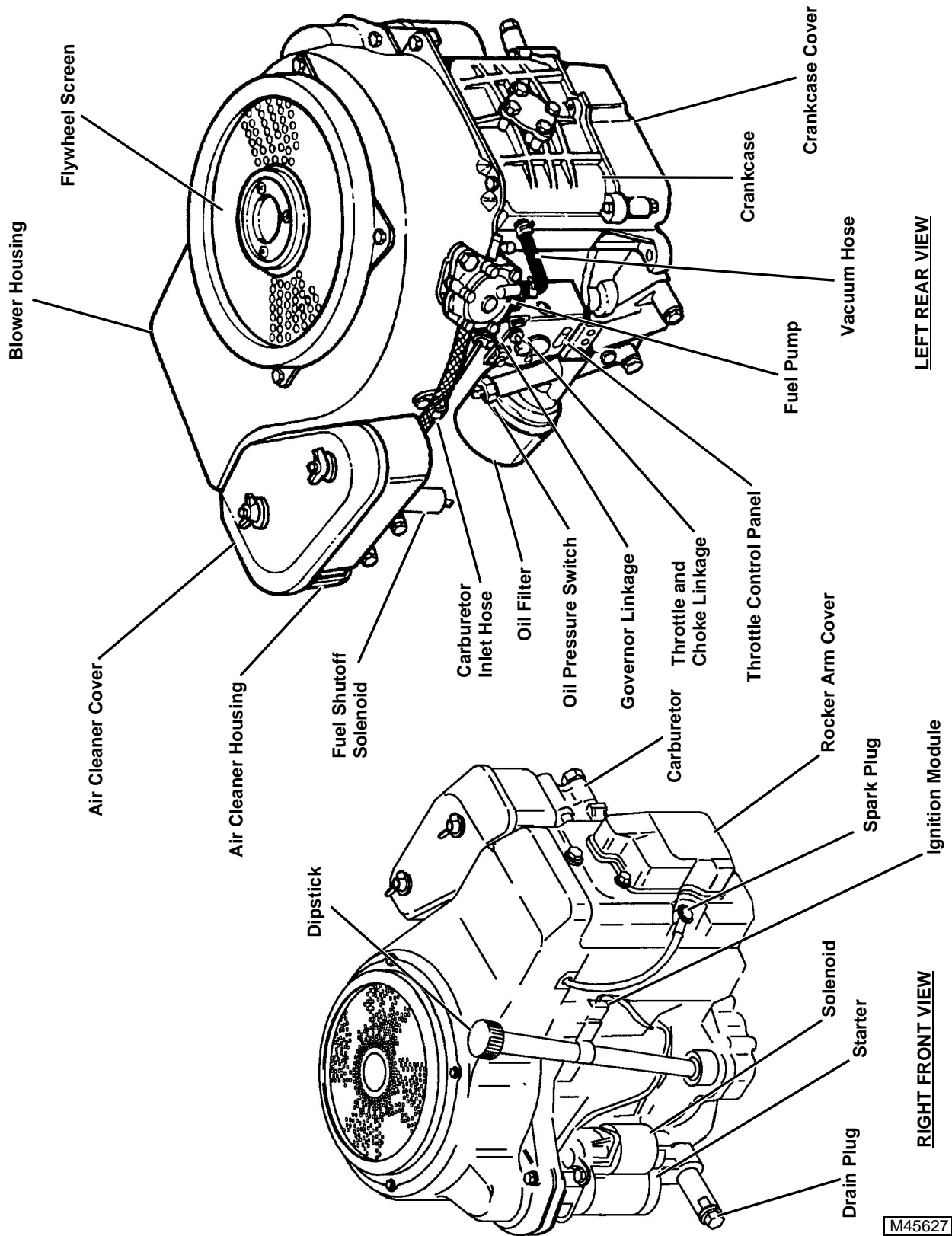

M45627

INTERNAL ENGINE COMPONENTS

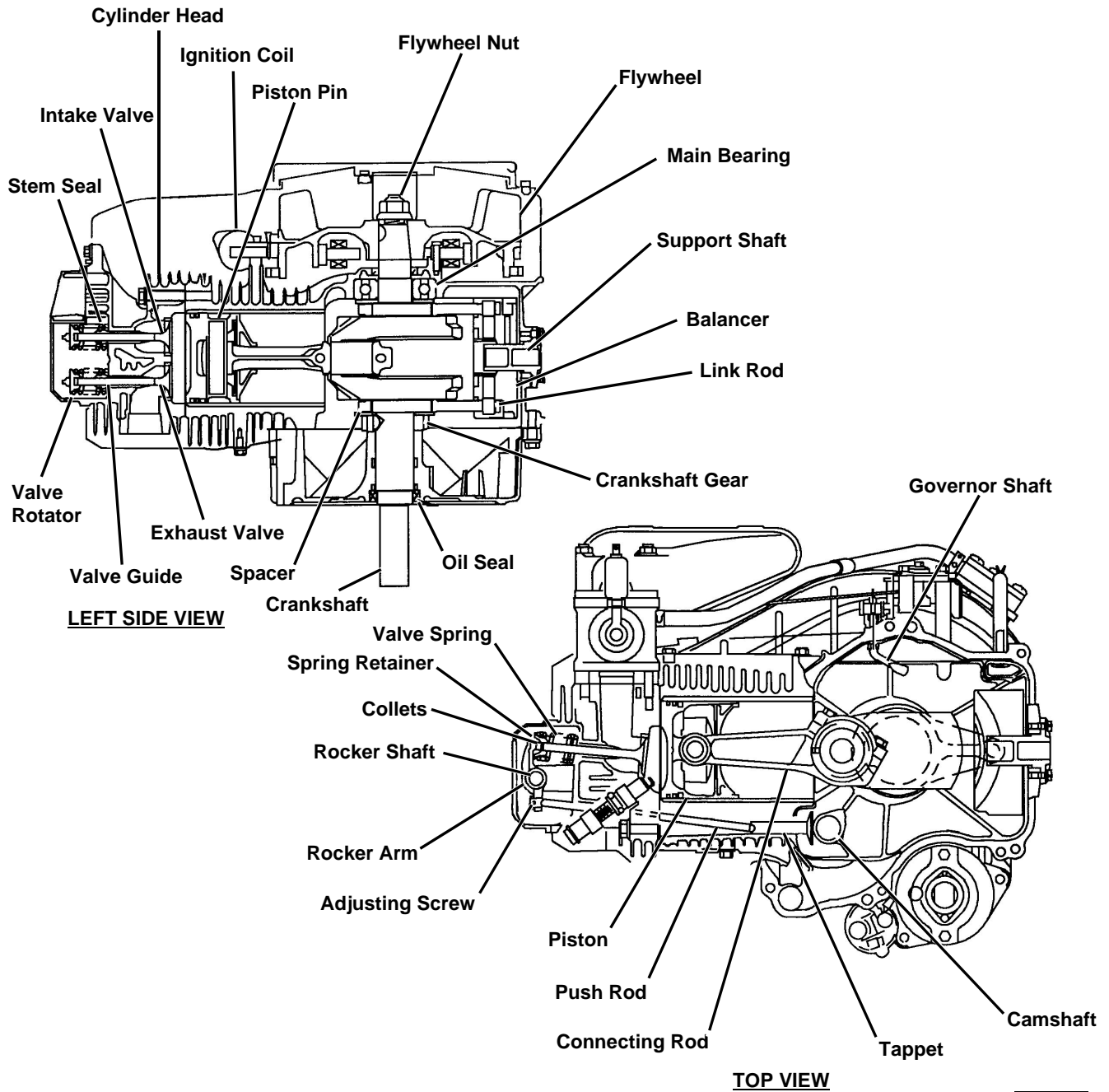

M45811

OIL PUMP BREATHER AND COMPRESSION RELEASE COMPONENTS

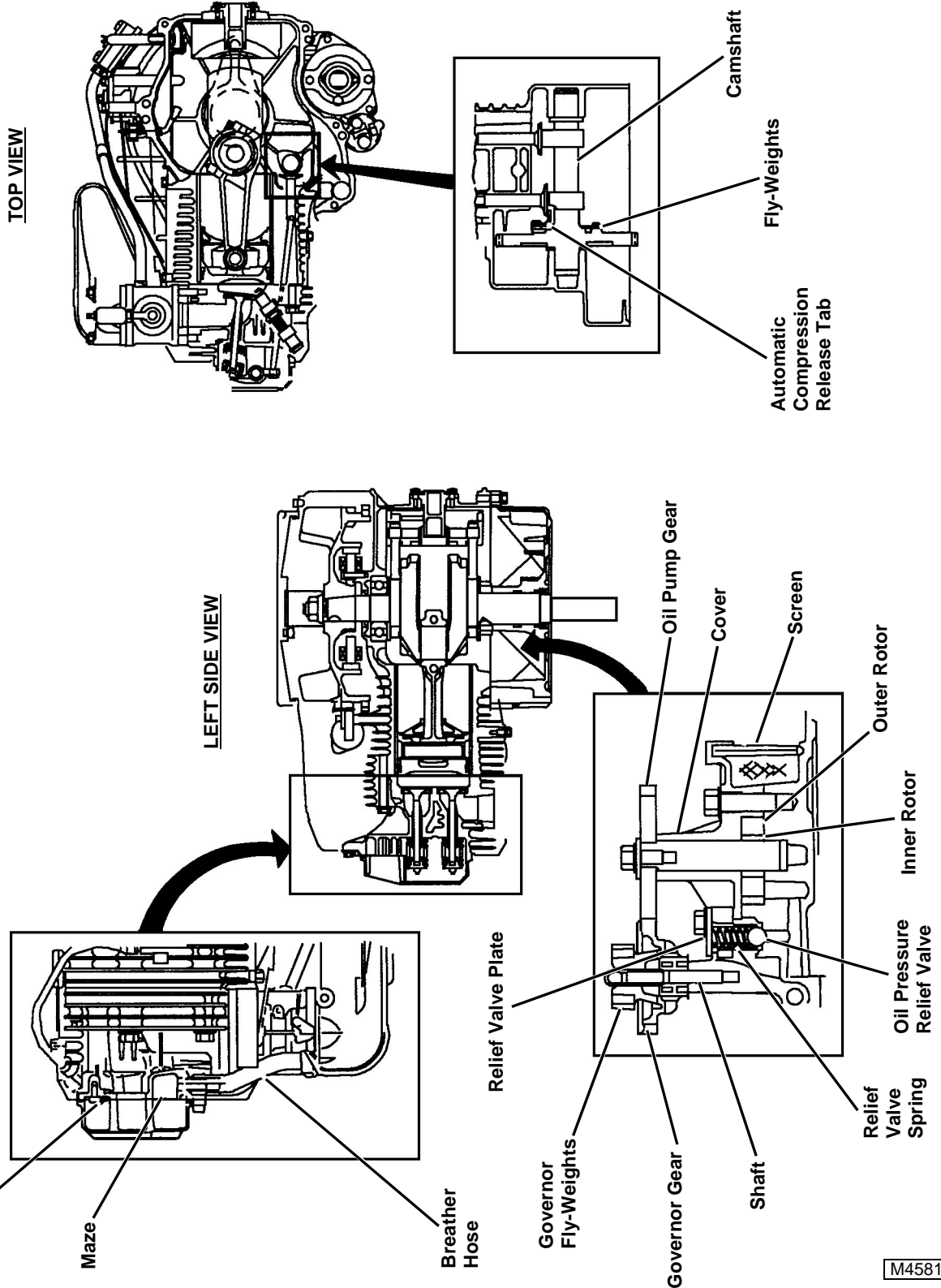

FUEL/AIR SYSTEM COMPONENTS

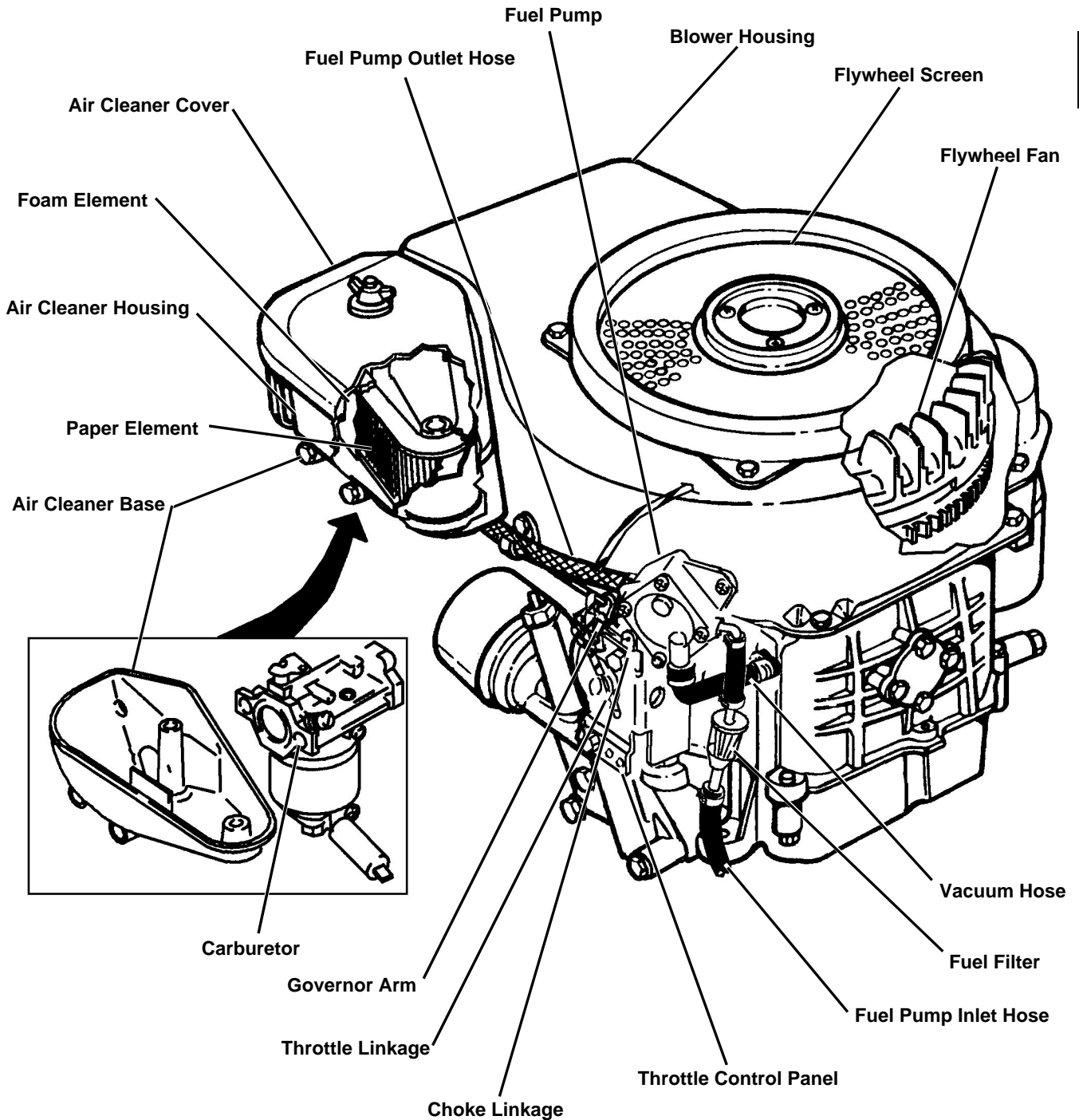

LEFT REAR VIEW

M45665

THEORY OF OPERATION

LUBRICATION SYSTEM OPERATION

Function:

To provide pressurized oil to lubricate internal engine components.

**Theory of Operation:**

A positive displacement gerotor pump is used to pressurize the lubrication system. The oil pump is driven directly off the crankshaft gear. The lubrication system is protected by an oil pressure relief valve, low oil pressure switch, and an oil filter with bypass.

The oil pump draws oil from the sump through the pick-up screen. Pressure oil from the pump flows through the pump outlet passage past the oil pressure relief valve. The oil pressure relief valve limits the oil pressure to approximately 296 kPa (43 psi) and protects the oil pump from damage if an oil passage becomes blocked. If oil pressure exceeds 296 kPa (43 psi), the relief valve opens allowing oil to return to sump. Relief valve is not adjustable.

Pressure oil from the relief valve flows to the oil filter. The filter contains a bypass valve which opens if the element becomes plugged to ensure engine lubrication.

An oil pressure switch mounted in the oil filter manifold turns on a warning light if oil pressure is below 28 kPa (4 psi). Filtered pressure oil flows through a passage in the oil sump to the crankshaft main bearing (PTO side) and then to the camshaft bearing. Drilled passages in the crankshaft distribute oil from the main bearings to the lower balancer link, connecting rod journal, upper balancer link, and crankshaft ball bearing (flywheel side). A drilled passage in the connecting rods allow oil from the connecting rod journal to lubricate the piston and cylinder walls.

Pressure-free oil flowing out of the crankshaft ball bearing or upper balancer link also lubricates the balancer. A drilled passage in the top of the balancer allows oil to flow to the support shaft and balancer bushing.

The rocker arms, valves, and pushrods are lubricated by an oil/air mixture and carried to the rocker arm cover through the breather passage. The breather passage is located directly above the upper pushrod. The oil from the oil/air mixture is separated from the air through the breather maze and flows to the bottom of the cylinder head. This oil drains back to the sump through an oil return passage located in the bottom of the cylinder block directly under the lower pushrod.



Suggest:

If the above button click is invalid.

Please download this document

first, and then click the above link

to download the complete manual.

Thank you so much for reading

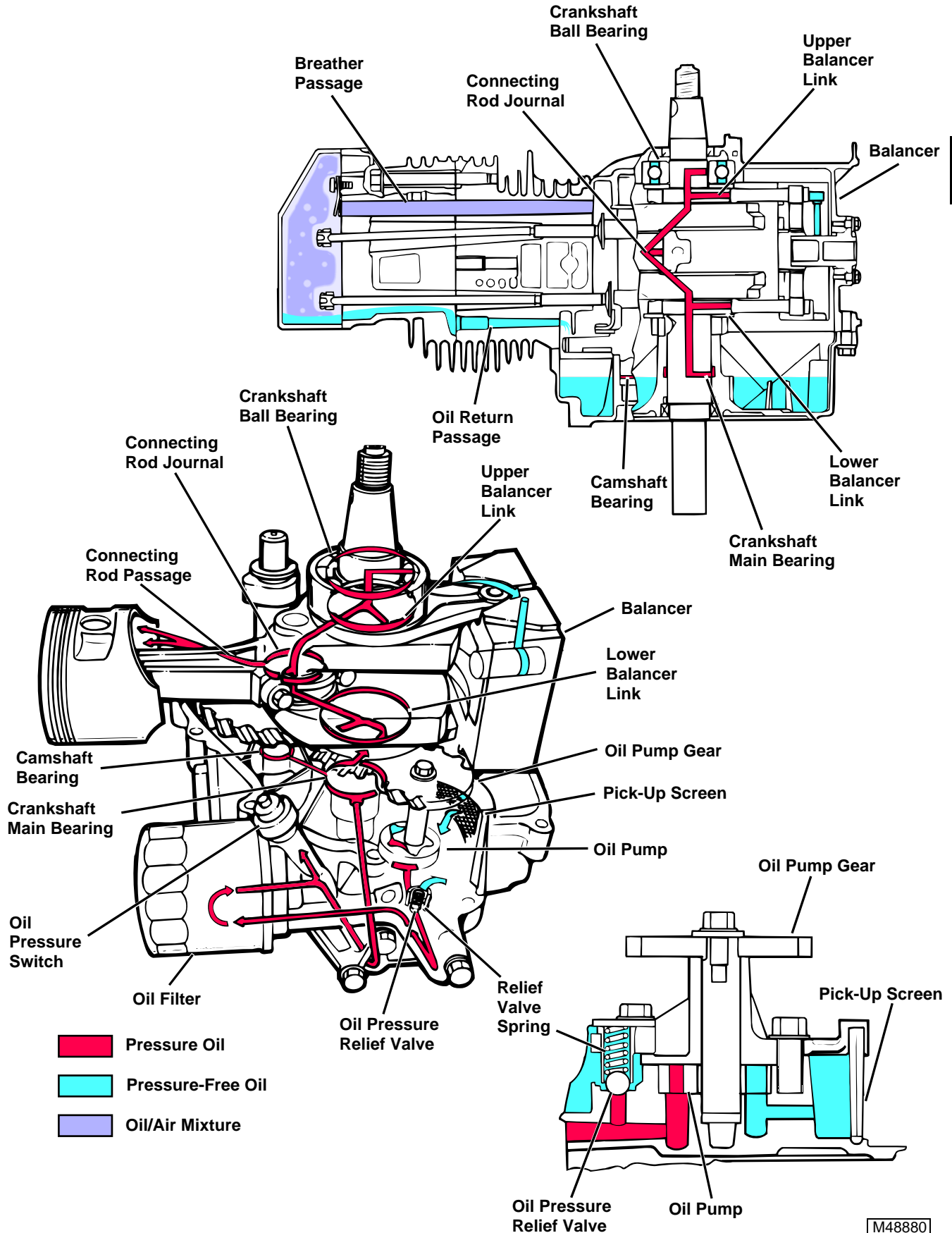

<https://www.ebooklibonline.com>

Hello dear friend!

Thank you very much for reading.

Enter the link into your browser.

The full manual is available for immediate download.

<https://www.ebooklibonline.com>