

**Scotts Lawn Tractor
L1642, L17.542, L2048 and L2548**

TM1949 JAN02

TECHNICAL MANUAL



***Manufactured
by John Deere***



JOHN DEERE

North American Version
Litho in U.S.A.

INTRODUCTION

Manual Description

This technical manual is written for an experienced technician and contains sections that are specifically for this product. It is a part of a total product support program.

The manual is organized so that all the information on a particular system is kept together. The order of grouping is as follows:

Table of Contents

General Diagnostic Information

Specifications

Electrical Wiring Harness Legend

Component Location

System Schematic

Wiring Harness

Troubleshooting Chart

Theory of Operation

Diagnostics

Tests & Adjustments

Repair

Depending on the particular section or system being covered, not all of the above groups may be used.

Each section will be identified with a symbol rather than a number. The groups and pages within a section will be consecutively numbered.

We appreciate your input on this manual. To help, there are postage paid post cards included at the back. If you find any errors or want to comment on the layout of the manual please fill out one of the cards and mail it back to us.

Safety

Specifications and Information

Engine - Briggs & Stratton (Single)

Engine - Briggs & Stratton (Twin)

Engine - Kohler

Electrical

Power Train - Gear Transmission

Power Train - Hydro Transmission

Steering

Brakes

Attachments

Miscellaneous

All information, illustrations and specifications in this manual are based on the latest information at the time of publication. The right is reserved to make changes at any time without notice.

COPYRIGHT© 2002

Deere & Co.

John Deere Worldwide Commercial and
Consumer Equipment Division

All rights reserved

Previous Editions

COPYRIGHT©

SAFETY

Recognize Safety Information

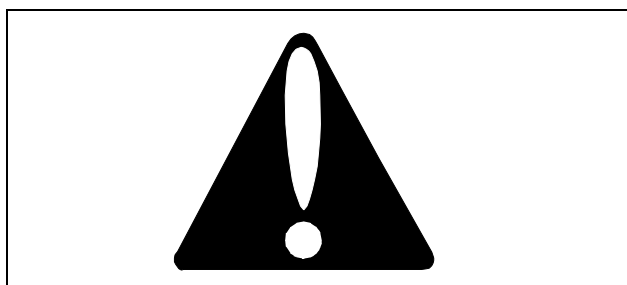

This is the safety-alert symbol. When you see this symbol on your machine or in this manual, be alert to the potential for personal injury.

Follow recommended precautions and safe servicing practices.

Understand Signal Words

A signal word—DANGER, WARNING, or CAUTION—is used with the safety-alert symbol. DANGER identifies the most serious hazards.

DANGER or WARNING safety signs are located near specific hazards. General precautions are listed on CAUTION safety signs. CAUTION also calls attention to safety messages in this manual.

Replace Safety Signs

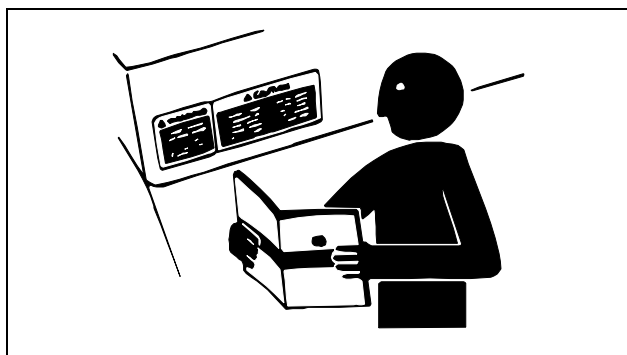

Replace missing or damaged safety signs. See the machine operator's manual for correct safety sign placement.

Be Prepared For Emergencies

- When you work around fuel, do not smoke or work near heaters or other fire hazards.
- Store flammable fluids away from fire hazards. Do not incinerate or puncture pressurized containers.

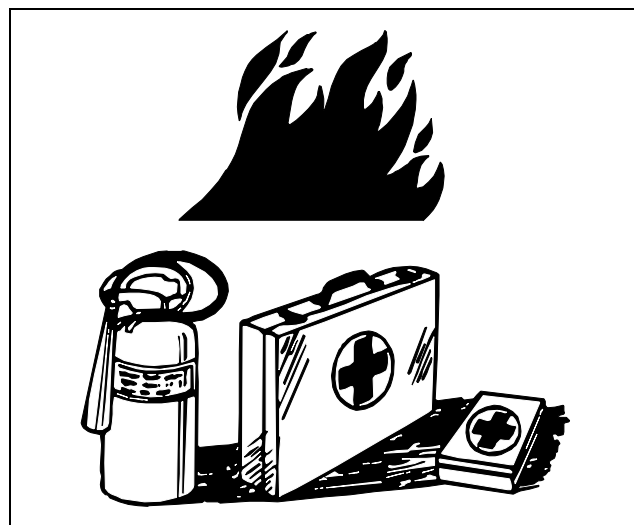

- Make sure machine is clean of trash, grease, and debris.
- Do not store oily rags; they can ignite and burn spontaneously.
- Be prepared if a fire starts.
- Keep a first aid kit and fire extinguisher handy.
- Keep emergency numbers for doctors, ambulance service, hospital, and fire department near your telephone.

Use Care In Handling And Servicing Batteries

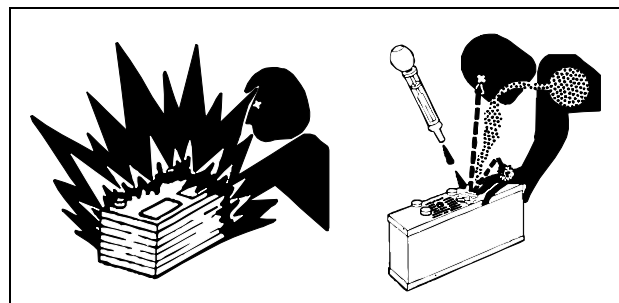

Prevent Battery Explosions

- Keep sparks, lighted matches, and open flame away from the top of battery. Battery gas can explode.
- Never check battery charge by placing a metal object across the posts. Use a volt-meter or hydrometer.
- Do not charge a frozen battery; it may explode. Warm battery to 16°C (60°F).

Prevent Acid Burns

- Sulfuric acid in battery electrolyte is poisonous. It is strong enough to burn skin, eat holes in clothing, and cause blindness if splashed into eyes.

<https://www.ebooklibonline.com>

Hello dear friend!

Thank you very much for reading.

Enter the link into your browser.

The full manual is available for immediate download.

<https://www.ebooklibonline.com>

SAFETY

Avoid acid burns by:

1. Filling batteries in a well-ventilated area.
2. Wearing eye protection and rubber gloves.
3. Avoiding breathing fumes when electrolyte is added.
4. Avoiding spilling or dripping electrolyte.
5. Use proper jump start procedure.

If you spill acid on yourself:

1. Flush your skin with water.
2. Apply baking soda or lime to help neutralize the acid.
3. Flush your eyes with water for 10_15 minutes.
4. Get medical attention immediately.

If acid is swallowed:

1. Drink large amounts of water or milk.
2. Then drink milk of magnesia, beaten eggs, or vegetable oil.
3. Get medical attention immediately.

Wear Protective Clothing

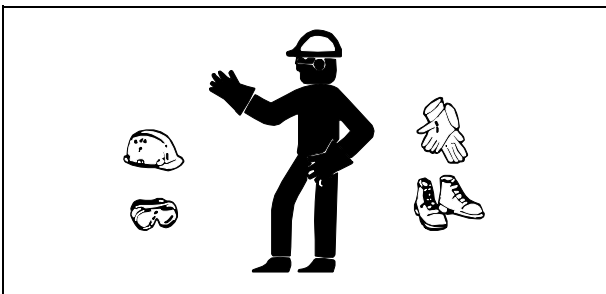

Wear close fitting clothing and safety equipment appropriate to the job.

Prolonged exposure to loud noise can cause impairment or loss of hearing. Wear a suitable hearing protective device such as earmuffs or earplugs to protect against objectionable or uncomfortable loud noises.

Operating equipment safely requires the full attention of the operator. Do not wear radio or music headphones while operating machine.

Service Machines Safely

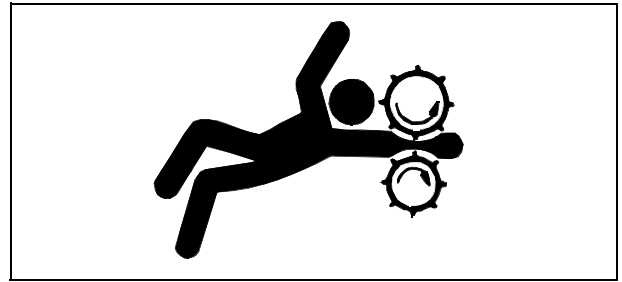

Tie long hair behind your head. Do not wear a necktie, scarf, loose clothing, or necklace when you work near machine tools or moving parts. If these items were to get caught, severe injury could result.

Remove rings and other jewelry to prevent electrical shorts and entanglement in moving parts.

Use Proper Tools

Use tools appropriate to the work. Makeshift tools and procedures can create safety hazards. Use power tools only to loosen threaded parts and fasteners. For loosening and tightening hardware, use the correct size tools. **DO NOT** use U.S. measurement tools on metric fasteners. Avoid bodily injury caused by slipping wrenches. Use only service parts meeting John Deere specifications.

Park Machine Safely

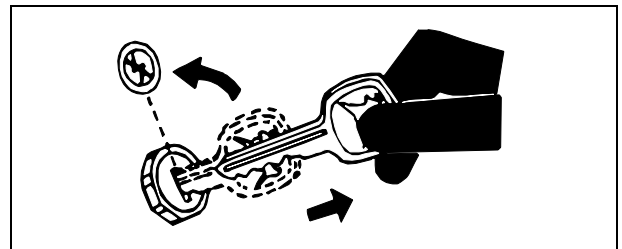

Before working on the machine:

1. Lower all equipment to the ground.
2. Stop the engine and remove the key.
3. Disconnect the battery ground strap.
4. Hang a "DO NOT OPERATE" tag in operator station.

Support Machine Properly And Use Proper Lifting Equipment

If you must work on a lifted machine or attachment, securely support the machine or attachment.

Do not support the machine on cinder blocks, hollow tiles,

SAFETY

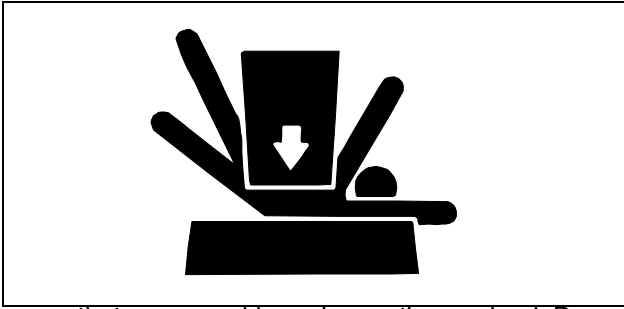

or props that may crumble under continuous load. Do not work under a machine that is supported solely by a jack. Follow recommended procedures in this manual.

Lifting heavy components incorrectly can cause severe injury or machine damage. Follow recommended procedure for removal and installation of components in the manual.

Work In Clean Area

Before starting a job:

1. Clean work area and machine.
2. Make sure you have all necessary tools to do your job.
3. Have the right parts on hand.
4. Read all instructions thoroughly; do not attempt shortcuts.

Using High Pressure Washers

Directing pressurized water at electronic/electrical components or connectors, bearings, hydraulic seals, fuel injection pumps or other sensitive parts and components may cause product malfunctions. Reduce pressure and spray at a 45 to 90 degree angle.

Illuminate Work Area Safely

Illuminate your work area adequately but safely. Use a portable safety light for working inside or under the machine. Make sure the bulb is enclosed by a wire cage. The hot filament of an accidentally broken bulb can ignite spilled fuel or oil.

Work In Ventilated Area

Engine exhaust fumes can cause sickness or death. If it is necessary to run an engine in an enclosed area, remove the exhaust fumes from the area with an exhaust pipe extension.

If you do not have an exhaust pipe extension, open the doors and get outside air into the area.

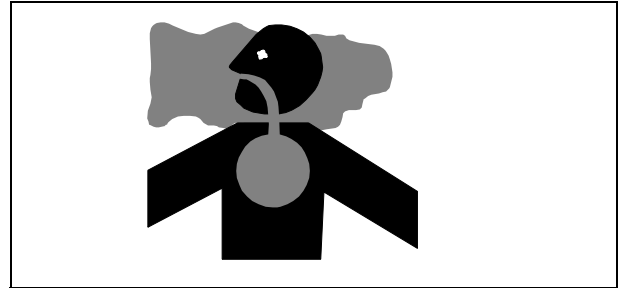

Warning: California Proposition 65 Warning

Gasoline engine exhaust from this product contains chemicals known to the State of California to cause cancer, birth defects, or other reproductive harm.

Remove Paint Before Welding Or Heating

Avoid potentially toxic fumes and dust. Hazardous fumes can be generated when paint is heated by welding, soldering, or using a torch. Do all work outside or in a well ventilated area. Dispose of paint and solvent properly. Remove paint before welding or heating: If you sand or grind paint, avoid breathing the dust. Wear an approved respirator. If you use solvent or paint stripper, remove stripper with soap and water before welding. Remove solvent or paint stripper containers and other flammable material from area. Allow fumes to disperse at least 15 minutes before welding or heating.

Avoid Harmful Asbestos Dust

Avoid breathing dust that may be generated when handling components containing asbestos fibers. Inhaled asbestos fibers may cause lung cancer.

Components in products that may contain asbestos fibers are brake pads, brake band and lining assemblies, clutch plates, and some gaskets. The asbestos used in these components is usually found in a resin or sealed in some way. Normal handling is not hazardous as long as airborne dust containing asbestos is not generated.

Avoid creating dust. Never use compressed air for cleaning. Avoid brushing or grinding material containing asbestos. When servicing, wear an approved respirator. A special vacuum cleaner is recommended to clean asbestos. If not available, apply a mist of oil or water on the material containing asbestos. Keep bystanders away from the area.

SAFETY

Service Tires Safely



Explosive separation of a tire and rim parts can cause serious injury or death.

Do not attempt to mount a tire unless you have the proper equipment and experience to perform the job.

Always maintain the correct tire pressure. Do not inflate the tires above the recommended pressure. Never weld or heat a wheel and tire assembly. The heat can cause an increase in air pressure resulting in a tire explosion. Welding can structurally weaken or deform the wheel.

When inflating tires, use a clip-on chuck and extension hose long enough to allow you to stand to one side and NOT in front of or over the tire assembly. Use a safety cage if available.

Check wheels for low pressure, cuts, bubbles, damaged rims or missing lug bolts and nuts.

Avoid Injury From Rotating Blades, Augers And Pto Shafts

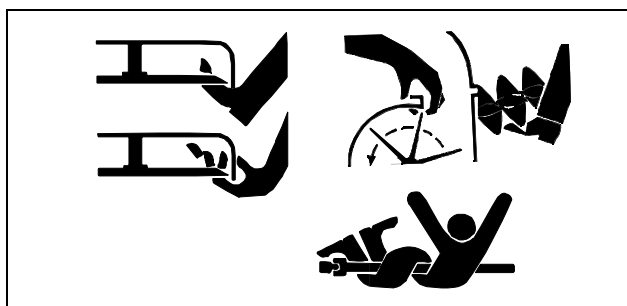

Keep hands and feet away while machine is running. Shut off power to service, lubricate or remove mower blades, augers or PTO shafts.

Handle Chemical Products Safely

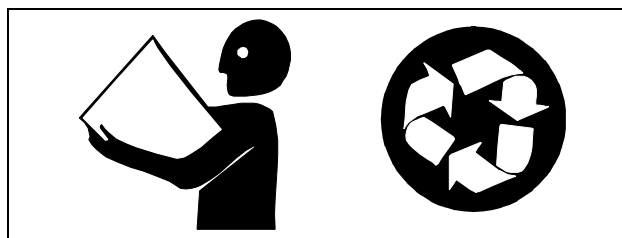

Direct exposure to hazardous chemicals can cause serious injury. Potentially hazardous chemicals used with John Deere equipment include such items as lubricants, coolants, paints, and adhesives.

A Material Safety Data Sheet (MSDS) provides specific details on chemical products: physical and health hazards, safety procedures, and emergency response techniques. Check the MSDS before you start any job using a hazardous chemical. That way you will know exactly what the risks are and how to do the job safely. Then follow procedures and recommended equipment.

Dispose Of Waste Properly

Improperly disposing of waste can threaten the environment and ecology. Potentially harmful waste used with John Deere equipment include such items as oil, fuel, coolant, brake fluid, filters, and batteries. Use leakproof containers when draining fluids. Do not use food or beverage containers that may mislead someone into drinking from them. Do not pour waste onto the ground, down a drain, or into any water source. Inquire on the proper way to recycle or dispose of waste from your local environmental or recycling center, or from your John Deere dealer.

Live With Safety



Before returning machine to customer, make sure machine is functioning properly, especially the safety systems. Install all guards and shields.

SPECIFICATIONS & INFORMATION / TABLE OF CONTENTS

Table of Contents

| | |
|---|-----------|
| Specifications | 7 |
| Engine | 7 |
| Fuel System | 8 |
| Electrical | 8 |
| Transaxle | 9 |
| PTO Drive | 9 |
| Steering | 10 |
| Implement Lift | 10 |
| Tires | 10 |
| Dimensions | 10 |
| Mower Decks | 10 |
| Recommended Lubricants | 11 |
| Fastener Torques | 12 |
| Metric Fastener Torque Values | 12 |
| Metric Fastener Torque Value—grade 7 | 13 |
| Inch Fastener Torque Values | 13 |
| General Information | 15 |
| Gasoline | 15 |
| Gasoline Storage | 15 |
| Engine Oil | 15 |
| Engine Break-in Oil | 16 |
| Alternative Lubricants | 16 |
| Synthetic Lubricants | 17 |
| Lubricant Storage | 17 |
| Mixing Of Lubricants | 17 |
| Chassis Grease | 17 |
| Hydrostatic Transmission Oil | 17 |
| Serial Number Locations | 18 |
| Machine Product Identification Number | 18 |
| Engine Serial Number | 18 |
| Transaxle Serial Number | 18 |

SPECIFICATIONS & INFORMATION / SPECIFICATIONS

Specifications

Engine

L1742

| | |
|-------------------------------------|----------------------------------|
| Make | Briggs & Stratton |
| Model | Intek / 31E707 |
| Horsepower | 12.7 kW (17.0 hp) |
| Displacement | 508 cm ³ (31 cu in.) |
| Cylinders | 1 |
| Stroke/Cycle | 4 |
| Valves | Overhead |
| Lubrication | Pressurized |
| Oil Filter | None |
| Crankcase Capacity (Without Filter) | 1.4 L (1.5 qt) |
| Cooling System | Air Cooled |
| Air Cleaner | Paper with outer foam element |
| Muffler | Horizontal discharge below frame |
| Spark Plug Gap | 1 mm (0.040 in.) |
| Spark Plug Torque | 26 N•m (240 lb-in.) |

L17.542

| | |
|-------------------------------------|---|
| Make | Kohler |
| Model | Command / CV490S |
| Horsepower | 13.1 kW (17.5 hp) |
| Displacement | 490 cm ³ (29.9 cu in.) |
| Cylinders | 1 |
| Stroke/Cycle | 4 |
| Valves | Overhead |
| Lubrication | Pressurized |
| Oil Filter | Single Element, Full Flow, Spin-On Filter |
| Crankcase Capacity (With Filter) | 1.9 L (2.0 qt) |
| Crankcase Capacity (Without Filter) | 1.8 L (1.75 qt) |
| Cooling System | Air Cooled |
| Air Cleaner | Paper with outer foam element |
| Muffler | Horizontal discharge below frame |
| Spark Plug Gap | 1 mm (0.040 in.) |
| Spark Plug Torque | 26 N•m (240 lb-in.) |

L2048

| | |
|--------------|-----------------------------------|
| Make | Briggs & Stratton |
| Model | Intek V-Twin / 406777 |
| Horsepower | 14.9 kW (20 HP) |
| Displacement | 656 cm ³ (40.0 cu in.) |

SPECIFICATIONS & INFORMATION / SPECIFICATIONS

| | |
|-------------------------------------|---|
| Cylinders | 2 |
| Stoke/Cycle | 4 |
| Valves | Overhead |
| Lubrication | Pressurized |
| Oil Filter | Single Element, Full Flow, Spin-On Filter |
| Crankcase Capacity (With Filter) | 1.9 L (2.0 qt) |
| Crankcase Capacity (Without Filter) | 1.7 L (1.9 qt) |
| Cooling System | Air Cooled |
| Air Cleaner | Dry, Replaceable Foam |
| Muffler | Horizontal Discharge Below Frame |
| Spark Plug Gap | 0.76 mm (0.030 in.) |
| Spark Plug Torque | 26 N•m (240 lb-in.) |

L2548

| | |
|-------------------------------------|---|
| Make | Briggs & Stratton |
| Model | Intek V-Twin / 445777 |
| Horsepower | 18.64 kW (25 HP) |
| Displacement | 724 cm ³ (44.2 cu in.) |
| Cylinders | 2 |
| Stoke/Cycle | 4 |
| Valves | Overhead |
| Lubrication | Pressurized |
| Oil Filter | Single Element, Full Flow, Spin-On Filter |
| Crankcase Capacity (With Filter) | 1.9 L (2.0 qt) |
| Crankcase Capacity (Without Filter) | 1.8 L (1.75 qt) |
| Cooling System | Air Cooled |
| Air Cleaner | Dry, Replaceable Foam |
| Muffler | Horizontal discharge below frame |
| Spark Plug Gap | 0.76 mm (0.030 in.) |
| Spark Plug Torque | 26 N•m (240 lb-in.) |

Fuel System

| | |
|------------------------------|--|
| Fuel Tank Location | Rear |
| Fuel Tank Capacity | 7.9 L (2.1 gal) |
| Fuel Type (minimum octane) | Unleaded, 87 Octane |
| Fuel Delivery | Float-Type Side Draft Carburetor |
| Fuel Pump | Vacuum Operated |
| Fuel Filter | Replaceable In-Line |
| Fuel Filter Opening/Location | 7.6 cm (3 in.) Diameter/Left Rear Fender |

Electrical

| | |
|-----------------|---|
| Ignition | Electronic Capacitor Discharge Ignition (CDI) |
| Type of Starter | Bendix |

SPECIFICATIONS & INFORMATION / SPECIFICATIONS

Charging System Flywheel Alternator

Battery

Voltage 12
 BCI group U-1
 CCA rating (Amps At -18°C (0°F)) 160
 Reserve capacity (Minutes At 25 Amps) 20
 Specific gravity (Minimum) 1.225 points
 Electrolyte required fill (Approximate) 1.9 L (2.0 qt)
 Load test (Minimum) 255 amp for 15 seconds

Transaxle

Gear Transaxle

Make Dana
 Model (L1742) Spicer Heavy-Duty 4360 Transaxle
 Type Five-Speed/Linear Shift
Ground Speeds (At Fast Idle—3350 rpm) and Gear Ratios:
 1st Gear 2.4 km/hr (1.5 mph)—61.67:1
 2nd Gear 3.2 km/hr (2.0 mph)—46.67:1
 3rd Gear 5.0 km/hr (3.1 mph)—30.00:1
 4th Gear 6.4 km/hr (4.0 mph)—23.48:1
 5th Gear 8.0 km/hr (5.0 mph)—18.46:1
 Reverse 3.7 km/hr (2.3 mph)—40.00:1
 Brake Type Single, External Brake Disc With Dual Friction Pucks
 Lubrication—Input Shaft Needle Bearings Unirex® N3 Grease Only (M120263)
 Lubrication—Transaxle Shell Darina® D Grease Only (AM119608)
 Capacity—Transaxle 0.64 kg (1.406 lbs)

Hydrostatic Transaxle:

Make Tuff Torq®
 Model (L17.542) K46V (7A6460)
 Model (L2048 and L2548) K46AC (7A6460) (Heavy-Duty)
 Drive Train Belt Drive Transaxle with foot-controlled variable speed drive
 Travel Speed-Forward (L17.542) 0 – 9.2 km/h (0 – 5.7 mph)
 Travel Speed-Forward (L2048 and L2548) 0 – 8.4 km/h (0 – 5.2 mph)
 Travel Speed-Reverse (L17.542) 0 – 5.5 km/h (0 – 3.4 mph)
 Travel Speed-Reverse (L2048 and L2548) 0 – 4.7 km/h (0 – 2.9 mph)
 Brake type Single, Internal Wet Disc Brake

PTO Drive

Type V-Belt
 Clutch Type (L1742 and L17.542) Mechanical
 Clutch Type (L2048 and L2548) Electric

SPECIFICATIONS & INFORMATION / SPECIFICATIONS

Control Lever or knob on Dash

Steering

Type Sector and Pinion
Turning Radius 46 cm (18 in.)

Implement Lift

Lift System Manual
Lift Arm Location Left-hand side

Tires

L1742 and L17.542

Front Tire Size 15 x 6.00 x 6
Front Tire Pressure 97 kPa (14 psi)
Rear Tire Size 20 x 8.00 x 8
Rear Tire Pressure 69 kPa (10 psi)

L2048 and L2548

Front Tire Size 16 x 6.50 x 8
Front Tire Pressure 97 kPa (14 psi)
Rear Tire Size 22 x 9.50 x 12
Rear Tire Pressure 69 kPa (10 psi)

Dimensions

Overall Length 152.4 cm (60.0 in.)
Overall Width (without mower) 91.0 cm (36.0 in.)
Overall Height 98.0 cm (38.6 in.)

Net Weight (No Fuel)

L1742 and L17.542 210 kg (462 lbs)
L2048 and L2548 241 kg (532 lbs)

Mower Decks

42-Inch Mower Deck:

Type Rotary - Mulch, Bag or Side Discharge
Cutting Blade Two—63.5 x 4 x 545 mm (2.5 x 0.16 x 21.5 in.)
Blade Cutting Edge 30 ± 5° Angle
Overall Cutting Width 106.7 cm (42 in.)
Cutting Height (approximate) 25 – 102 mm (1 – 4 in.)
Blade cap screw 62 N•m (46 lb-ft)
Gage wheels-to-deck 34 N•m (25 lb-ft)
Spindle mounting screws 27 N•m (20 lb-ft)
Spindle Lubrication Do not grease

SPECIFICATIONS & INFORMATION / SPECIFICATIONS

48-Inch Mower Deck:

| | |
|------------------------------------|---|
| Type | Rotary - Mulch, Bag or Side Discharge |
| Cutting Blade | Three—63.5 x 4 x 433 mm (2.5 x 0.16 x 17 in.) |
| Blade Cutting Edge | 30 ± 5° Angle |
| Overall Cutting Width | 121.9 cm (48 in.) |
| Cutting Height (approximate) | 25 – 102 mm (1 – 4 in.) |
| Blade cap screw | 62 N•m (46 lb-ft) |
| Gage wheels to deck | 30 N•m (22 lb-ft) |
| Spindle mounting screws | 27 N•m (20 lb-ft) |
| Spindle lubrication | Do not grease |

Recommended Lubricants

| | |
|------------------------|--|
| Engine Oil | TURF-GARD® OR PLUS-4® |
| Transmission Oil | John Deere Low Viscosity HY-GARD® (J20D) |

Grease:

John Deere MOLY HIGH TEMPERATURE EP GREASE

John Deere Multi-Purpose SD Polyurea Grease

John Deere Multi-Purpose HD Lithium Complex Grease

(Specifications and design subject to change without notice.)

SPECIFICATIONS & INFORMATION / FASTENER TORQUES

Fastener Torques

Metric Fastener Torque Values

| | | | | |
|---|------------|---------------------|-------------|-------------|
| Property Class and Head Markings | <p>4.8</p> | <p>8.8 9.8</p> | <p>10.9</p> | <p>12.9</p> |
| Property Class and Nut Markings | <p>5</p> | <p>10</p> | <p>10</p> | <p>12</p> |

TS1163

| SIZE | Class 4.8 | | | | Class 8.8 or 9.8 | | | | Class 10.9 | | | | Class 12.9 | | | |
|------|--------------|-------|-------|-------|------------------|-------|-------|-------|--------------|-------|-------|-------|--------------|-------|-------|-------|
| | Lubricated a | | Dry a | | Lubricated a | | Dry a | | Lubricated a | | Dry a | | Lubricated a | | Dry a | |
| | N•m | lb-ft | N•m | lb-ft | N•m | lb-ft | N•m | lb-ft | N•m | lb-ft | N•m | lb-ft | N•m | lb-ft | N•m | lb-ft |
| M6 | 4.8 | 3.5 | 6 | 4.5 | 9 | 6.5 | 11 | 8.5 | 13 | 9.5 | 17 | 12 | 15 | 11.5 | 19 | 14.5 |
| M8 | 12 | 8.5 | 15 | 11 | 22 | 16 | 28 | 20 | 32 | 24 | 40 | 30 | 37 | 28 | 47 | 35 |
| M10 | 23 | 17 | 29 | 21 | 43 | 32 | 55 | 40 | 63 | 47 | 80 | 60 | 75 | 55 | 95 | 70 |
| M12 | 40 | 29 | 50 | 37 | 75 | 55 | 95 | 70 | 110 | 80 | 140 | 105 | 130 | 95 | 165 | 120 |
| M14 | 63 | 47 | 80 | 60 | 120 | 88 | 150 | 110 | 175 | 130 | 225 | 165 | 205 | 150 | 260 | 109 |
| M16 | 100 | 73 | 125 | 92 | 190 | 140 | 240 | 175 | 275 | 200 | 350 | 225 | 320 | 240 | 400 | 300 |
| M18 | 135 | 100 | 175 | 125 | 260 | 195 | 330 | 250 | 375 | 275 | 475 | 350 | 440 | 325 | 560 | 410 |
| M20 | 190 | 140 | 240 | 180 | 375 | 275 | 475 | 350 | 530 | 400 | 675 | 500 | 625 | 460 | 800 | 580 |
| M22 | 260 | 190 | 330 | 250 | 510 | 375 | 650 | 475 | 725 | 540 | 925 | 675 | 850 | 625 | 1075 | 800 |
| M24 | 330 | 250 | 425 | 310 | 650 | 475 | 825 | 600 | 925 | 675 | 1150 | 850 | 1075 | 800 | 1350 | 1000 |
| M27 | 490 | 360 | 625 | 450 | 950 | 700 | 1200 | 875 | 1350 | 1000 | 1700 | 1250 | 1600 | 1150 | 2000 | 1500 |
| M30 | 675 | 490 | 850 | 625 | 1300 | 950 | 1650 | 1200 | 1850 | 1350 | 2300 | 1700 | 2150 | 1600 | 2700 | 2000 |
| M33 | 900 | 675 | 1150 | 850 | 1750 | 1300 | 2200 | 1650 | 2500 | 1850 | 3150 | 2350 | 2900 | 2150 | 3700 | 2750 |
| M36 | 1150 | 850 | 1450 | 1075 | 2250 | 1650 | 2850 | 2100 | 3200 | 2350 | 4050 | 3000 | 3750 | 2750 | 4750 | 3500 |

DO NOT use these hand torque values if a different torque value or tightening procedure is given for a specific application. Torque values listed are for general use only and include a $\pm 10\%$ variance factor. Check tightness of fasteners periodically. DO NOT use air powered wrenches.

Shear bolts are designed to fail under predetermined loads. Always replace shear bolts with identical grade.

Fasteners should be replaced with the same class. Make sure fastener threads are clean and that you properly start thread engagement. This will prevent them from failing when tightening.

When bolt and nut combination fasteners are used, torque values should be applied to the NUT instead of the bolt head.

Tighten toothed or serrated-type lock nuts to the full torque value.

a "Lubricated" means coated with a lubricant such as engine oil, or fasteners with phosphate and oil coatings. "Dry" means plain or zinc plated (Yellow Dichromate - Specification JDS117) without any lubrication.

Reference: JDS—G200









SPECIFICATIONS & INFORMATION / FASTENER TORQUES

Metric Fastener Torque Value—grade 7

| Size | Steel or Gray Iron Torque | | Aluminum Torque | |
|------|---------------------------|-------|-----------------|-------|
| | N•m | lb-ft | N•m | lb-ft |
| M6 | 11 | 8 | 8 | 6 |
| M8 | 24 | 18 | 19 | 14 |
| M10 | 52 | 38 | 41 | 30 |

| Size | Steel or Gray Iron Torque | | Aluminum Torque | |
|------|---------------------------|-------|-----------------|-------|
| | N•m | lb-ft | N•m | lb-ft |
| M12 | 88 | 65 | 70 | 52 |
| M14 | 138 | 102 | 111 | 82 |
| M16 | 224 | 165 | 179 | 132 |

Inch Fastener Torque Values

| | | | |
|-----------------------------|---|--|---|
| SAE Grade and Head Markings | 1 or 2 ^b No Marks  | 5  5.1  5.2  | 8  8.2  |
| | SAE Grade and Nut Markings | 2  | 5   |

TS1162

TS1162

| SIZE | Grade 1 | | | | Grade 2b | | | | Grade 5, 5.1 or 5.2 | | | | Grade 8 or 8.2 | | | |
|-------|--------------|-------|-------|-------|--------------|-------|-------|-------|---------------------|-------|-------|-------|----------------|-------|-------|-------|
| | Lubricated a | | Dry a | | Lubricated a | | Dry a | | Lubricated a | | Dry a | | Lubricated a | | Dry a | |
| | N•m | lb-ft | N•m | lb-ft | N•m | lb-ft | N•m | lb-ft | N•m | lb-ft | N•m | lb-ft | N•m | lb-ft | N•m | lb-ft |
| 1/4 | 3.7 | 2.8 | 4.7 | 3.5 | 6 | 4.5 | 7.5 | 5.5 | 9.5 | 7 | 12 | 9 | 13.5 | 10 | 17 | 12.5 |
| 5/16 | 7.7 | 5.5 | 10 | 7 | 12 | 9 | 15 | 11 | 20 | 15 | 25 | 18 | 28 | 21 | 35 | 26 |
| 3/8 | 14 | 10 | 17 | 13 | 22 | 16 | 27 | 20 | 35 | 26 | 44 | 33 | 50 | 36 | 63 | 46 |
| 7/16 | 22 | 16 | 28 | 20 | 35 | 26 | 44 | 32 | 55 | 41 | 70 | 52 | 80 | 58 | 100 | 75 |
| 1/2 | 33 | 25 | 42 | 31 | 53 | 39 | 67 | 50 | 85 | 63 | 110 | 80 | 120 | 90 | 150 | 115 |
| 9/16 | 48 | 36 | 60 | 45 | 75 | 56 | 95 | 70 | 125 | 90 | 155 | 115 | 175 | 130 | 225 | 160 |
| 5/8 | 67 | 50 | 85 | 62 | 105 | 78 | 135 | 100 | 170 | 125 | 215 | 160 | 215 | 160 | 300 | 225 |
| 3/4 | 120 | 87 | 150 | 110 | 190 | 140 | 240 | 175 | 300 | 225 | 375 | 280 | 425 | 310 | 550 | 400 |
| 7/8 | 190 | 140 | 240 | 175 | 190 | 140 | 240 | 175 | 490 | 360 | 625 | 450 | 700 | 500 | 875 | 650 |
| 1 | 290 | 210 | 360 | 270 | 290 | 210 | 360 | 270 | 725 | 540 | 925 | 675 | 1050 | 750 | 1300 | 975 |
| 1-1/8 | 470 | 300 | 510 | 375 | 470 | 300 | 510 | 375 | 900 | 675 | 1150 | 850 | 1450 | 1075 | 1850 | 1350 |
| 1-1/4 | 570 | 425 | 725 | 530 | 570 | 425 | 725 | 530 | 1300 | 950 | 1650 | 1200 | 2050 | 1500 | 2600 | 1950 |
| 1-3/8 | 750 | 550 | 950 | 700 | 750 | 550 | 950 | 700 | 1700 | 1250 | 2150 | 1550 | 2700 | 2000 | 3400 | 2550 |
| 1-1/2 | 1000 | 725 | 1250 | 925 | 990 | 725 | 1250 | 930 | 2250 | 1650 | 2850 | 2100 | 3600 | 2650 | 4550 | 3350 |

SPECIFICATIONS & INFORMATION / FASTENER TORQUES

DO NOT use these hand torque values if a different torque value or tightening procedure is given for a specific application. Torque values listed are for general use only and include a $\pm 10\%$ variance factor. Check tightness of fasteners periodically. DO NOT use air powered wrenches.

Shear bolts are designed to fail under predetermined loads. Always replace shear bolts with identical grade.

Fasteners should be replaced with the same grade. Make sure fastener threads are clean and that you properly start thread engagement. This will prevent them from failing when tightening.

When bolt and nut combination fasteners are used, torque values should be applied to the NUT instead of the bolt head.

Tighten toothed or serrated-type lock nuts to the full torque value.

a *“Lubricated” means coated with a lubricant such as engine oil, or fasteners with phosphate and oil coatings.*

“Dry” means plain or zinc plated (yellow dichromate - Specification JDS117) without any lubrication.

b *“Grade 2” applies for hex cap screws (Not Hex Bolts) up to 152 mm (6—in.) long. “Grade 1” applies for hex cap screws over 152 mm (6—in.) long, and for all other types of bolts and screws of any length.*

Reference: JDS—G200

SPECIFICATIONS & INFORMATION / GENERAL INFORMATION

General Information

Gasoline



CAUTION: Avoid injury! Gasoline is HIGHLY FLAMMABLE, handle it with care. DO NOT refuel machine while:

indoors, always fill gas tank outdoors

machine is near an open flame or sparks

engine is running, STOP engine

engine is hot, allow it to cool sufficiently first
smoking

Help prevent fires:

fill gas tank to bottom of filler neck only

be sure fill cap is tight after fueling

clean up any gas spills IMMEDIATELY

keep machine clean and in good repair—free of excess grease, oil, debris, and faulty or damaged parts

any storage of machines with gas left in tank should be in an area that is well ventilated to prevent possible igniting of fumes by an open flame or spark, this includes any appliance with a pilot light

To prevent fire or explosion caused by STATIC ELECTRIC DISCHARGE during fueling:

ONLY use a clean, approved POLYETHYLENE PLASTIC fuel container and funnel WITHOUT any metal screen or filter

To avoid engine damage:

- DO NOT mix oil with gasoline
- **ONLY use clean, fresh unleaded gasoline with an octane rating (anti-knock index) of 87 or higher**
- fill gas tank at the end of each day's operation to help prevent condensation from forming inside a partially filled tank
- keep up with specified service intervals

Use of alternative oxygenated, gasohol blended, unleaded gasoline is acceptable as long as:

- the ethyl or grain alcohol blends DO NOT exceed 10% by volume or

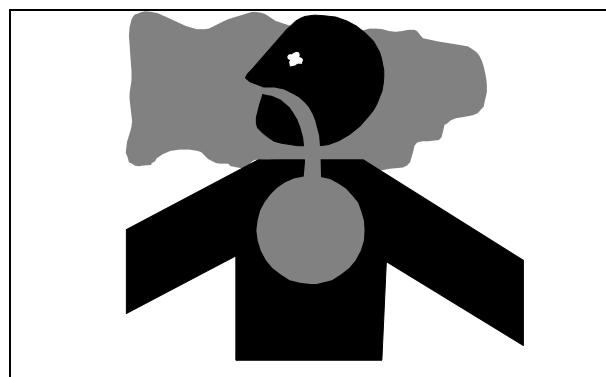

mif

- methyl tertiary butyl ether (MTBE) blends DO NOT exceed 15% by volume

IMPORTANT: Avoid damage! DO NOT use METHANOL gasolines because METHANOL is harmful to the environment and to your health.



CAUTION: Avoid injury! California Proposition 65 Warning: Gasoline engine exhaust from this product contains chemicals known to the State of California to cause cancer, birth defects, or other reproductive harm.

Gasoline Storage

IMPORTANT: Avoid damage! Keep all dirt, scale, water or other foreign material out of gasoline.

Keep gasoline stored in a safe, protected area. Storage of gasoline in a clean, properly marked ("UNLEADED GASOLINE") POLYETHYLENE PLASTIC container WITHOUT any metal screen or filter is recommended. DO NOT use de-icers to attempt to remove water from gasoline or depend on fuel filters to remove water from gasoline. Use a water separator installed in the storage tank outlet. BE SURE to properly discard unstable or contaminated gasoline. When storing unit or gasoline, it is recommended that you add **John Deere Gasoline Conditioner and Stabilizer (TY15977)** or an equivalent to the gasoline. BE SURE to follow directions on container and to properly discard empty container.

Engine Oil

Use the appropriate oil viscosity based on the expected air temperature range during the period between recommended oil changes. Operating outside of these recommended oil air temperature ranges may cause premature engine failure.

The following John Deere oil is PREFERRED:

SPECIFICATIONS & INFORMATION / GENERAL INFORMATION

- **TURF-GARD®—SAE 10W-30;**
- **PLUS-4®—SAE 10W-30;**

Other oils may be used if above John Deere oils are not available, provided they meet one of the following specifications:

- SAE 5W-30—API Service Classification SG or higher;
- SAE 10W-30—API Service Classification SG or higher;
- SAE 30—API Service Classification SC or higher.

John Deere Dealers: You may want to cross-reference the following publications to recommend the proper oil for your customers:

- Module DX, ENOIL2 in JDS-G135;
- Section 530, Lubricants & Hydraulics, of the John Deere Merchandise Sales Guide;
- Lubrication Sales Manual PI7032.

Engine Break-in Oil

IMPORTANT: Avoid damage! ONLY use a quality break-in oil in rebuilt or remanufactured engines for the first 5 hours (maximum) of operation. DO NOT use oils with heavier viscosity weights than SAE 5W-30 or oils meeting specifications API SG or SH, these oils will not allow rebuilt or remanufactured engines to break-in properly.

The following John Deere oil is **PREFERRED**:

- **BREAK-IN ENGINE OIL.**

John Deere **BREAK-IN ENGINE OIL** is formulated with special additives for aluminum and cast iron type engines to allow the power cylinder components (pistons, rings, and liners as well) to “wear-in” while protecting other engine components, valve train and gears, from abnormal wear. Engine rebuild instructions should be followed closely to determine if special requirements are necessary.

John Deere **BREAK-IN ENGINE OIL** is also recommended for non-John Deere engines, both aluminum and cast iron types.

The following John Deere oil is **also recommended as a break-in engine oil**:

- **TORQ-GARD SUPREME®—SAE 5W-30.**

If the above recommended John Deere oils are not available, use a break-in engine oil meeting the following specification during the first 5 hours (maximum) of operation:

- SAE 5W-30—API Service Classification SE or higher.

IMPORTANT: Avoid damage! After the break-in period, use the John Deere oil that is recommended for this engine.

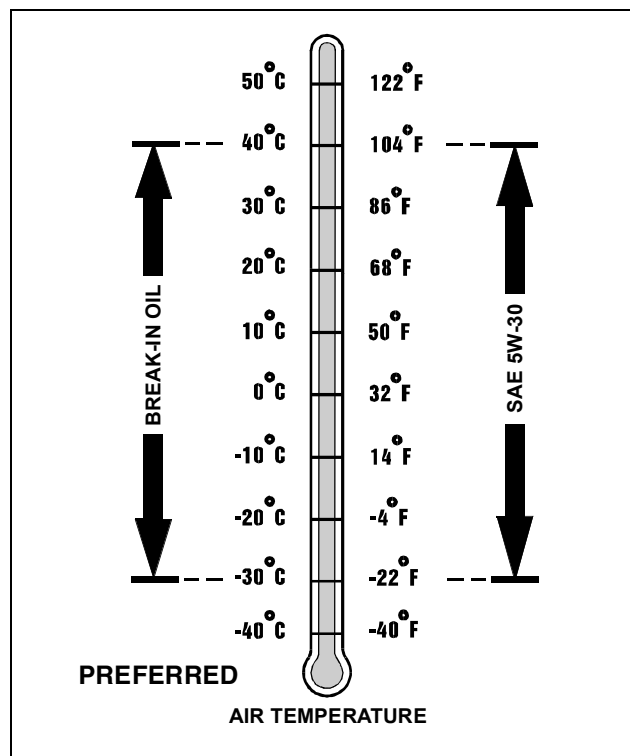

M58275

John Deere Dealers: You may want to cross-reference the following publications to recommend the proper oil for your customers:

- Module DX, ENOIL4 in JDS-G135;
- Section 530, Lubricants & Hydraulics, of the John Deere Merchandise Sales Guide;
- Lubrication Sales Manual PI7032.

Alternative Lubricants

Conditions in certain geographical areas outside the United States and Canada may require different lubricant recommendations than the ones printed in this technical manual or the operator's manual. Consult with your John Deere Dealer, or Sales Branch, to obtain the alternative lubricant recommendations.

IMPORTANT: Avoid damage! Use of alternative lubricants could cause reduced life of the component.

If alternative lubricants are to be used, it is recommended that the factory fill be thoroughly removed before switching to any alternative lubricant.

SPECIFICATIONS & INFORMATION / GENERAL INFORMATION

Synthetic Lubricants

Synthetic lubricants may be used in John Deere equipment if they meet the applicable performance requirements (industry classification and/or military specification) as shown in this manual.

The recommended air temperature limits and service or lubricant change intervals should be maintained as shown in the operator's manual.

Avoid mixing different brands, grades, or types of oil. Oil manufacturers blend additives in their oils to meet certain specifications and performance requirements. Mixing different oils can interfere with the proper functioning of these additives and degrade lubricant performance.

Lubricant Storage

All machines operate at top efficiency only when clean lubricants are used. Use clean storage containers to handle all lubricants. Store them in an area protected from dust, moisture, and other contamination. Store drums on their sides. Make sure all containers are properly marked as to their contents. Dispose of all old, used containers and their contents properly.

Mixing Of Lubricants

In general, avoid mixing different brands or types of lubricants. Manufacturers blend additives in their lubricants to meet certain specifications and performance requirements. Mixing different lubricants can interfere with the proper functioning of these additives and lubricant properties which will downgrade their intended specified performance.

Chassis Grease

Use the following grease based on the air temperature range. Operating outside of the recommended grease air temperature range may cause premature failures.

The following John Deere grease is PREFERRED:

- **NON-CLAY HIGH-TEMPERATURE EP GREASE®—JDM J13E4, NLGI Grade 2.**

- Multi-Purpose SD Polyurea Grease
- Multi-Purpose HD Lithium Complex Grease

Other greases may be used if above preferred John Deere grease is not available, provided they meet the following specification:

- John Deere Standard JDM J13E4, NLGI Grade 2.

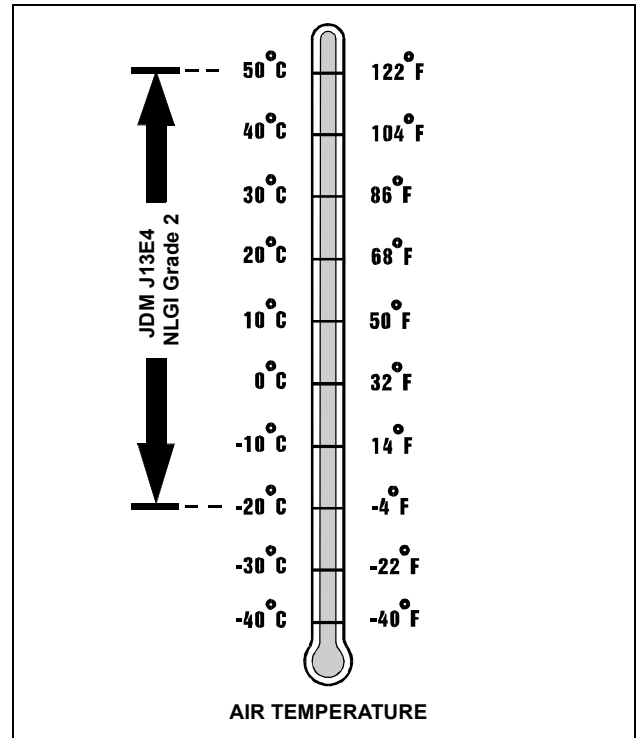

M58275

John Deere Dealers: You may want to cross-reference the following publications to recommend the proper grease for your customers:

- Module DX, GREA1 in JDS-G135;
- Section 530, Lubricants & Hydraulics, of the John Deere Merchandise Sales Guide;
- Lubrication Sales Manual P17032.

Hydrostatic Transmission Oil

These tractors are equipped with an internal wet disc brake transmission.

IMPORTANT: Avoid damage! ONLY use HY-GARD® J20D oil in this transmission. Mixing of two viscosity grade oils is NOT RECOMMENDED. DO NOT use type "F" automatic transmission fluid.

The following oil is RECOMMENDED:

- **HY-GARD J20D OIL**

John Deere Dealers: You may want to cross-reference the following publications to recommend the proper oil for your customers:

- Module DX, ENOIL2 in JDS-G135;
- Section 530, Lubricants & Hydraulics, of the John Deere Merchandise Sales Guide;
- Lubrication Sales Manual PI7032.

SPECIFICATIONS & INFORMATION / SERIAL NUMBER LOCATIONS

Serial Number Locations

Machine Product Identification Number

When ordering parts or submitting a warranty claim, it is **IMPORTANT** that the machine product identification number (PIN) and component serial numbers are included. The location of the PIN and component serial numbers are shown.

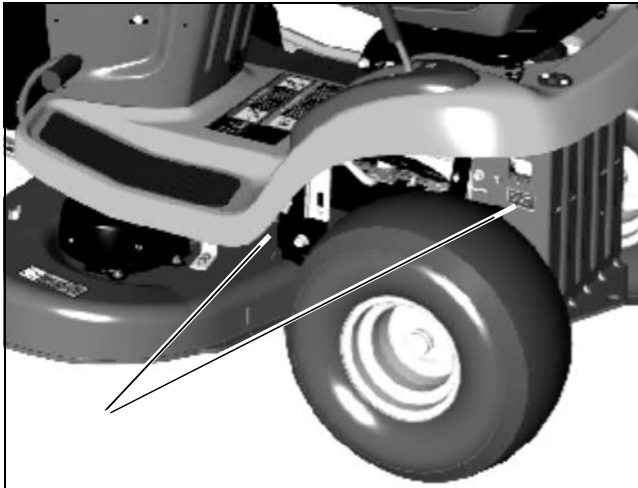

MX7694

Machine: Located on LH side of frame.

Mower Deck: Located on rear left side of deck.

Engine Serial Number



MX9662

Located on RH side of engine.

Transaxle Serial Number

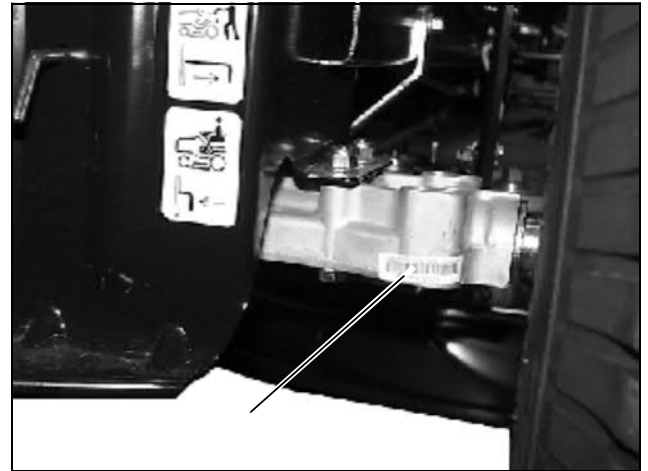

MX9663

Located on back-right side of transaxle.

ENGINE - 17 HP BRIGGS & STRATTON / TABLE OF CONTENTS

Table of Contents

| | | | |
|---|-----------|---|----|
| Specifications | 21 | Balance System Removal and Installation | 49 |
| General Specifications | 21 | Crankshaft/Cam Gear Installation | 50 |
| Tests and Adjustments Specifications | 21 | Magneto Bearing Inspection | 51 |
| Repair Specifications | 21 | Cam Gear Bearing Inspection | 52 |
| Torque Specifications (Alphabetical) | 22 | PTO Journal Inspection and Seal Replacement | 52 |
| Tests and Adjustments | 24 | Starting Motor Removal and Installation | 52 |
| Throttle Cable Adjustment | 24 | Starting Motor Disassembly | 53 |
| Throttle Cable Adjustment | 24 | Starting Motor Assembly | 55 |
| Fuel Shutoff Solenoid Test | 24 | Starting Motor Pinion Gear Replacement | 56 |
| Governor Adjustment - Static | 25 | | |
| Governor Adjustment - Dynamic | 25 | | |
| Governor Idle Adjustment | 26 | | |
| Slow Idle Carburetor Adjustment | 26 | | |
| Valve Clearance Adjustment | 27 | | |
| Armature Air Gap Adjustment | 28 | | |
| Cylinder Leakdown Test | 28 | | |
| Fuel and Air Repair | 30 | | |
| Upper Blower Housing Removal and Installation | 30 | | |
| Air Cleaner Service | 30 | | |
| Carburetor Removal and Installation | 31 | | |
| Carburetor Disassembly | 32 | | |
| Carburetor Inspection | 33 | | |
| Carburetor Assembly | 33 | | |
| Breather Valve Service | 34 | | |
| Engine Repair | 34 | | |
| Engine Removal | 34 | | |
| Engine Installation | 35 | | |
| Cylinder Head Removal and Installation | 36 | | |
| Cylinder Head Inspection and Repair | 39 | | |
| Valve Removal | 39 | | |
| Valves Reface | 39 | | |
| Valves Installation | 40 | | |
| Governor Removal and Installation | 41 | | |
| Piston, Rings and Rod | 41 | | |
| Piston Inspection | 43 | | |
| Connecting Rod Inspection | 43 | | |
| Cylinder Bore Inspection | 45 | | |
| Cylinder Bore Honing | 45 | | |
| Cylinder Bore Cleaning | 46 | | |
| Resizing Cylinder Bore 4 | 6 | | |
| Flywheel Removal and Installation | 47 | | |
| Crankshaft and Cam Gear Removal | 48 | | |

ENGINE - 17 HP BRIGGS & STRATTON / SPECIFICATIONS

Specifications

General Specifications

| | |
|------------------------|------------------------------------|
| Make | Briggs & Stratton |
| Series | I/C® OHV Model 28 |
| Model | 314777 |
| Horsepower | 12.7 kW (17 hp) |
| Cylinders | 1 |
| Displacement | 500 cm ³ (30.52 cu in.) |
| Stroke/Cycle | 4 |
| Valves | Overhead Valves |
| Bore | 90.47 mm (3.562 in.) |
| Stroke | 77.8 mm (3.06 in.) |
| Crankcase Oil Capacity | 1.42 L (1.5 qt) |
| Cooling System | Air Cooled |
| Air Cleaner | Paper with outer foam element |
| Muffler | Horizontal discharge below frame |
| Aspiration | Normal |
| Fuel Filter | Replaceable (In-Line Type) |

Tests and Adjustments Specifications

| | |
|-------------------|------------------------------------|
| Valve Clearance | |
| Intake | 0.08 – 0.13 mm (0.003 – 0.005 in.) |
| Exhaust | 0.13 – 0.18 mm (0.005 – 0.007 in.) |
| Valve Guide Depth | 0.12 – 0.15 mm (0.005 – 0.006 in.) |
| Slow Idle | 1700 ± 50 rpm |
| Fast Idle | 3350 ± 50 rpm |
| Magneto Air Gap | 0.20 – 0.35 mm (0.008 – 0.014 in.) |
| Spark Plug Gap | 0.76 mm (0.030 in.) |

Repair Specifications

Cylinder Bore, Pistons and Rings:

| | |
|----------------------------------|----------------------|
| Cylinder Bore Standard | |
| Maximum Dimension | 90.50 mm (3.563 in.) |
| Minimum Dimension | 90.47 mm (3.562 in.) |
| Cylinder Bore Out of Round (max) | 0.04 mm (0.0015 in.) |
| Piston Pin (Wear Limit) | 20.29 mm (0.799 in.) |
| Piston Pin Bore (Wear Limit) | 20.35 mm (0.801 in.) |

Ring End Gap (Wear Limit) Case Iron Bore:

| | |
|---------------------------|---------------------|
| Compression Ring (Top) | 0.64 mm (0.025 in.) |
| Compression Ring (Center) | 0.76 mm (0.030 in.) |
| Oil Ring | 0.76 mm (0.030 in.) |



Suggest:

If the above button click is invalid.

Please download this document

first, and then click the above link

to download the complete manual.

Thank you so much for reading

ENGINE - 17 HP BRIGGS & STRATTON / SPECIFICATIONS

Compression and Oil Ring Groove Wear Limit (New Ring Installed) 0.15 mm (0.006 in.)

Valves:

Valve Guide (Wear Limit) 6.09 mm (0.240 in.)

Valve Seat Width 0.79 – 1.98 mm (0.031 – 0.078 in.)

Valve Margin (Minimum) 0.40 mm (0.016 in.)

Valve Face Angle 45°

Valve Seat Narrowing Angle 30°

Connecting Rod and Crankshaft:

Connecting Rod Crankpin (Wear Limit) 38.32 mm (1.509 in.)

Connecting Rod Piston Pin Bearing (Wear Limit) 20.37 mm (0.802 in.)

Crankshaft PTO Journal (Wear Limit) 34.95 mm (1.376 in.)

Crankshaft Magneto Journal (Wear Limit) 34.95 mm (1.376 in.)

Crankshaft Crankpin Journal (Wear Limit) 38.02 mm (1.497 in.)

Crankshaft Eccentric Journal (Wear Limit) 55.93 mm (2.202 in.)

PTO Bearing (Wear Limit) 35.13 mm (1.383 in.)

Magneto Bearing (Wear Limit) 35.13 mm (1.383 in.)

Crankshaft End Play 0.05 – 0.58 mm (0.002 – 0.023 in.)

Cam Gear PTO Journal (Wear Limit) 12.65 mm (0.498 in.)

Cam Gear Magneto Journal (Wear Limit) 12.65 mm (0.498 in.)

Cam Lobe (Wear Limit) 30.07 mm (1.184 in.)

Cam Gear Bearing (Wear Limit) 12.8 mm (0.504 in.)

Counterweight:

Crankshaft Eccentric Journal (Wear Limit) 55.93 mm (2.202 in.)

Counterweight Link Bearing (Wear Limit) 56.13 mm (2.210 in.)

Torque Specifications (Alphabetical)

Blower Housing Screws 9.6 N•m (85 lb-in.)

Breather Mounting Bolt 6.2 N•m (55 lb-in.)

Breather Reed Screw 3.4 N•m (30 lb-in.)

Carburetor to Intake Manifold 8 N•m (70 lb-in.)

Carburetor Bowl Screw 4.5 N•m (40 lb-in.)

Connecting Rod Cap Screws 21 N•m (186 lb-in.)

Control Bracket Screws 3.4 N•m (30 lb-in.)

Cylinder Head Cap Screws 25 N•m (220 lb-in.)

Dip Stick Tube Mounting Screw 2.8 N•m (25 lb-in.)

Drive Belt Idler Pulley 9.6 N•m (85 lb-in.)

Engine Mounting Bolts 32 N•m (24 lb-ft)

Engine Output Pulley Assembly 75 N•m (55 lb-ft)

Exhaust Manifold 18.5 N•m (165 lb-in.)

Flywheel Fan Screws 16 N•m (140 lb-in.)

Flywheel Nut 136 N•m (100 lb-ft)

<https://www.ebooklibonline.com>

Hello dear friend!

Thank you very much for reading.

Enter the link into your browser.

The full manual is available for immediate download.

<https://www.ebooklibonline.com>