

# **JS Series 21-Inch Walk-Behind Mowers (Steel Deck)**

## **TECHNICAL MANUAL**

**John Deere  
Worldwide Commercial and  
Consumer Equipment Division**

**TM1710 (Mar01)  
Replaces TM1710 (10May99)**



M93006

**21-Inch Walk-Behind Mower (Steel Deck)**

**JS60, JS60H, JS61,  
JS63, JS63E, JS63C**

This technical manual is written for an experienced technician and contains sections that are specifically for this product. It is a part of a total product support program.

The manual is organized so that all the information on a particular system is kept together. The order of grouping is as follows:

- Table of Contents
- Specifications
- Component Location
- System Schematic
- Theory of Operation
- Troubleshooting Chart
- Diagnostics
- Tests & Adjustments
- Repair

*Note: Depending on the particular section or system being covered, not all of the above groups may be used.*

Each section will be identified with a symbol rather than a number. The groups and pages within a section will be consecutively numbered.

We appreciate your input on this manual. If you find any errors, or want to comment on the layout of the manual, please mail your comments back to us.

All information, illustrations and specifications in this manual are based on the latest information available at the time of publication. The right is reserved to make changes at any time without notice.

COPYRIGHT© 2001  
 Deere and Co.  
 John Deere Worldwide Commercial and  
 Consumer Equipment Division  
 Horicon, WI  
 All rights reserved

**Safety**



**Specifications and Information**



**Engine – Quantum**



**Engine – Intek**



**Power Train**



**Miscellaneous**



**<https://www.ebooklibonline.com>**

Hello dear friend!

Thank you very much for reading.

Enter the link into your browser.

The full manual is available for immediate download.

**<https://www.ebooklibonline.com>**



## Recognize Safety Information

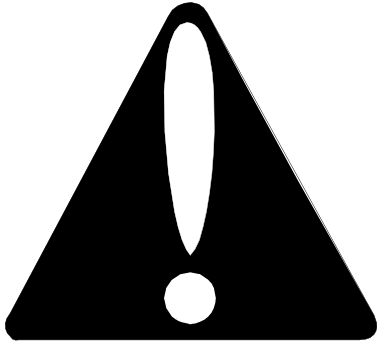

This is the safety-alert symbol. When you see this symbol on your machine or in this manual, be alert to the potential for personal injury.

Follow recommended precautions and safe servicing practices.

## Understand Signal Words

A signal word—DANGER, WARNING, or CAUTION—is used with the safety-alert symbol. DANGER identifies the most serious hazards.

DANGER or WARNING safety signs are located near specific hazards. General precautions are listed on CAUTION safety signs. CAUTION also calls attention to safety messages in this manual.

## Replace Safety Signs



Replace missing or damaged safety signs. See the machine operator's manual for correct safety sign placement.

## **WARNING: California Proposition 65 Warning**

Gasoline engine exhaust from this product contains chemicals known to the State of California to cause cancer, birth defects, or other reproductive harm.

## Handle Fluids Safely-Avoid Fires

## Be Prepared For Emergencies

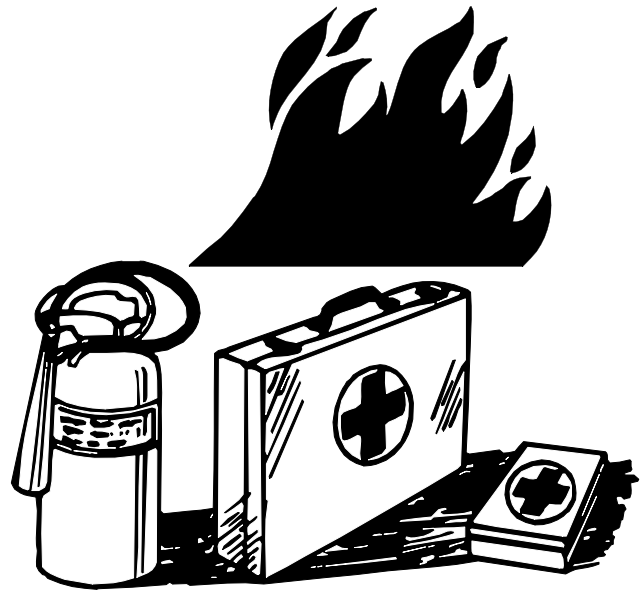

When you work around fuel, do not smoke or work near heaters or other fire hazards.

Store flammable fluids away from fire hazards. Do not incinerate or puncture pressurized containers.

Make sure machine is clean of trash, grease, and debris.

Do not store oily rags; they can ignite and burn spontaneously.

Be prepared if a fire starts.

Keep a first aid kit and fire extinguisher handy.

Keep emergency numbers for doctors, ambulance service, hospital, and fire department near your telephone.

## Wear Protective Clothing

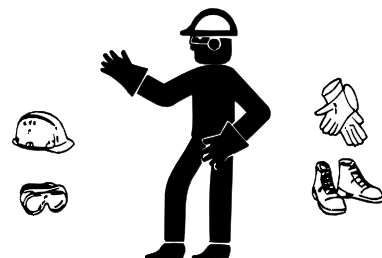

Wear close fitting clothing and safety equipment appropriate to the job.

Prolonged exposure to loud noise can cause impairment or loss of hearing. Wear a suitable hearing protective device such as earmuffs or earplugs to protect against objectionable or uncomfortable loud noises.

Operating equipment safely requires the full attention of the operator. Do not wear radio or music headphones while operating machine.

## Service Machines Safely

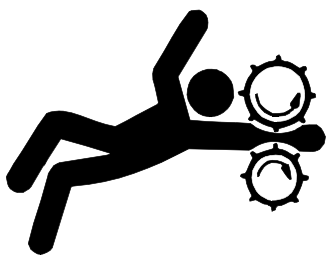

Tie long hair behind your head. Do not wear a necktie, scarf, loose clothing, or necklace when you work near machine tools or moving parts. If these items were to get caught, severe injury could result.

Remove rings and other jewelry to prevent electrical shorts and entanglement in moving parts.

## Use Proper Tools

Use tools appropriate to the work. Makeshift tools and procedures can create safety hazards. Use power tools only to loosen threaded parts and fasteners. For loosening and tightening hardware, use the correct size tools. **DO NOT** use U.S. measurement tools on metric fasteners. Avoid bodily injury caused by slipping wrenches. Use only service parts meeting John Deere specifications.

## Park Machine Safely

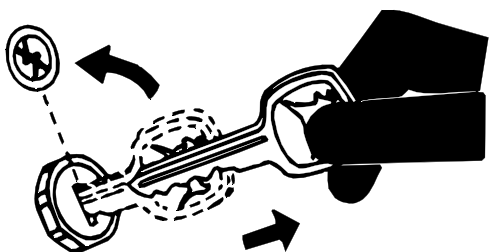

### Before working on the machine:

1. Lower all equipment to the ground.
2. Stop the engine and remove the key.
3. Hang a "DO NOT OPERATE" tag in operator station.

## Support Machine Properly And Use Proper Lifting Equipment

If you must work on a lifted machine or attachment, securely support the machine or attachment.

Do not support the machine on cinder blocks, hollow tiles, or props that may crumble under continuous load. Do not work under a machine that is supported solely by a jack. Follow recommended procedures in this manual.

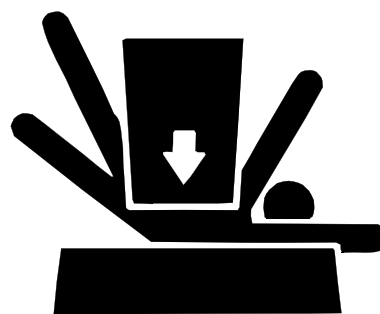

Lifting heavy components incorrectly can cause severe injury or machine damage. Follow recommended procedure for removal and installation of components in the manual.

## Avoid Injury From Rotating Blades and PTO Shafts

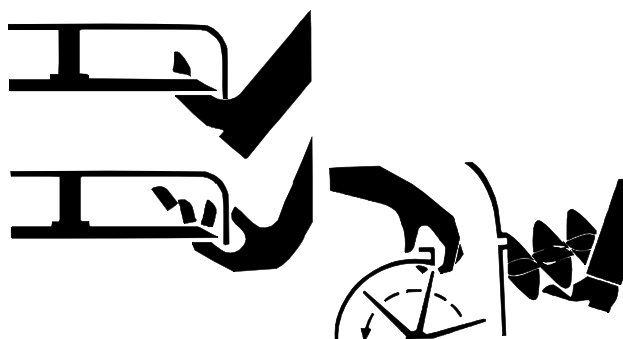

Keep hands and feet away while machine is running. Shut off power to service, lubricate or remove mower blades or PTO shafts.

## Work In Clean Area

### Before starting a job:

1. Clean work area and machine.
2. Make sure you have all necessary tools to do your job.
3. Have the right parts on hand.
4. Read all instructions thoroughly; do not attempt shortcuts.

## Using High Pressure Washers

Directing pressurized water at electronic/electrical components or connectors, bearings, or other sensitive parts and components may cause product malfunctions. Reduce pressure and spray at a 45 to 90 degree angle.

## Illuminate Work Area Safely

Illuminate your work area adequately but safely. Use a portable safety light for working inside or under the machine. Make sure the bulb is enclosed by a wire cage. The hot filament of an accidentally broken bulb can ignite spilled fuel or oil.





## Work In Ventilated Area

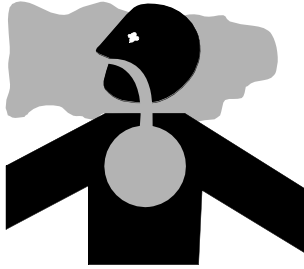

Engine exhaust fumes can cause sickness or death. If it is necessary to run an engine in an enclosed area, remove the exhaust fumes from the area with an exhaust pipe extension.

If you do not have an exhaust pipe extension, open the doors and get outside air into the area.

## Remove Paint Before Welding Or Heating

Avoid potentially toxic fumes and dust. Hazardous fumes can be generated when paint is heated by welding, soldering, or using a torch. Do all work outside or in a well ventilated area. Dispose of paint and solvent properly. Remove paint before welding or heating: If you sand or grind paint, avoid breathing the dust. Wear an approved respirator. If you use solvent or paint stripper, remove stripper with soap and water before welding. Remove solvent or paint stripper containers and other flammable material from area. Allow fumes to disperse at least 15 minutes before welding or heating.

## Avoid Harmful Asbestos Dust

Avoid breathing dust that may be generated when handling components containing asbestos fibers. Inhaled asbestos fibers may cause lung cancer.

Components in products that may contain asbestos fibers are brake pads, brake band and lining assemblies, clutch plates, and some gaskets. The asbestos used in these components is usually found in a resin or sealed in some way. Normal handling is not hazardous as long as airborne dust containing asbestos is not generated.

Avoid creating dust. Never use compressed air for cleaning. Avoid brushing or grinding material containing asbestos. When servicing, wear an approved respirator. A special vacuum cleaner is recommended to clean asbestos. If not available, apply a mist of oil or water on the material containing asbestos. Keep bystanders away from the area.

## Handle Chemical Products Safely

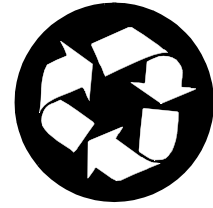
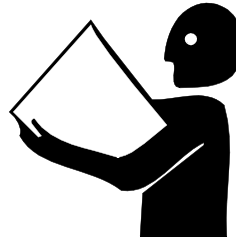

Direct exposure to hazardous chemicals can cause serious injury. Potentially hazardous chemicals used with John Deere equipment include such items as lubricants, coolants, paints, and adhesives.

A Material Safety Data Sheet (MSDS) provides specific details on chemical products: physical and health hazards, safety procedures, and emergency response techniques. Check the MSDS before you start any job using a hazardous chemical. That way you will know exactly what the risks are and how to do the job safely. Then follow procedures and recommended equipment.

## Dispose of Waste Properly

Improperly disposing of waste can threaten the environment and ecology. Potentially harmful waste used with John Deere equipment include such items as oil, fuel, coolant, brake fluid, filters, and batteries. Use leakproof containers when draining fluids. Do not use food or beverage containers that may mislead someone into drinking from them. Do not pour waste onto the ground, down a drain, or into any water source. Inquire on the proper way to recycle or dispose of waste from your local environmental or recycling center, or from your John Deere dealer.

## Live With Safety



Before returning machine to customer, make sure machine is functioning properly, especially the safety systems. Install all guards and shields.

# CONTENTS

	Page
<b>GENERAL SPECIFICATIONS</b> .....	<b>3</b>
ENGINE .....	3
ELECTRICAL .....	3
TRANSMISSION .....	3
<b>TORQUE SPECIFICATIONS</b> .....	<b>4</b>
DIMENSIONS .....	4
INCH FASTENER TORQUE VALUES .....	5
METRIC FASTENER TORQUE VALUES .....	6
<b>GASOLINE</b> .....	<b>7</b>
GASOLINE STORAGE .....	7
<b>ENGINE OIL</b> .....	<b>8</b>
ENGINE BREAK-IN OIL .....	8
<b>LUBRICANTS</b> .....	<b>9</b>
ANTI-CORROSION GREASE .....	9
CHASSIS GREASE .....	9
ALTERNATIVE LUBRICANTS .....	10
SYNTHETIC LUBRICANTS .....	10
LUBRICANT STORAGE .....	10
MIXING OF LUBRICANTS .....	10
<b>PRODUCT IDENTIFICATION LOCATIONS</b> .....	<b>10</b>



**GENERAL SPECIFICATIONS**

	<b>JS60, JS61, JS63</b>	<b>JS60H, JS61, JS63, JS63C</b>	<b>JS63E</b>
<b>ENGINE</b>			
Make	Briggs & Stratton (Quantum)	Briggs & Stratton (Intek)	Briggs & Stratton (Intek)
Model	12H802	121602	121607
Type	4-cycle gas/Air cooled	4-cycle gas/Air cooled	4-cycle gas/Air cooled
Cylinders	1	1	1
Valves	Side valves	Overhead	Overhead
Displacement	190 cc (11.6 cu in.)	190 cc (11.6 cu in.)	190 cc (11.6 cu in.)
Horsepower (SAE J1940)	4.5 kW (6 HP)	4.8 kW (6.5 HP)	4.8 kW (6.5 HP)
Lubrication	Splash	Splash	Splash
Oil Capacity	0.65 L (22.0 oz)	0.65 L (22.0 oz)	0.65 L (22.0 oz)
Throttle Control	Fixed speed	Fixed speed	Fixed speed
No-Load Speed	3200 ± 100 rpm	3200 ± 100 rpm	3200 ± 100 rpm
Carburetor	CARB/EPA Certified	CARB/EPA Certified	CARB/EPA Certified
Choke	Primer bulb	Primer bulb	Primer bulb
Cooling system	Air	Air	Air
Air cleaner	Dry replaceable single element	Dry replaceable single element	Dry replaceable single element
<b>ELECTRICAL</b>			
Ignition	Electronic	Electronic	Electronic
Spark Plug (resistor)	RCJ8 Champion	RC12YC Champion	RC12YC Champion
Spark Plug Gap	0.76 mm (0.030 in.)	0.51 mm (0.020 in.)	0.51 mm (0.020 in.)
<b>FUEL SYSTEM</b>			
Fuel type	Unleaded gasoline	Unleaded gasoline	Unleaded gasoline
Capacity	1.5 L (1.6 U.S. qt)	1.5 L (1.6 U.S. qt)	1.5 L (1.6 U.S. qt)
<b>TRANSMISSION</b>			
Type	Push	Push (JS60H) One Speed (JS61) Three Speed (JS63 and JS63C)	Three Speed
Drive belt Type	N/A	N/A (JS60H)	GC00081 3L
Effective Length		GC00073 3L 993 mm (39.09 in.) (JS61)	882.5 mm (34.74 in.)
		GC00081 3L 882.5 mm (34.74 in.) (JS63 and JS63C)	



1. Specifications and design subject to change without notice.

	<b>JS60, JS61, JS63</b>	<b>JS60H, JS61, JS63, JS63C</b>	<b>JS63E</b>
Transaxle	N/A	N/A (JS60H) Dana fully enclosed; grease lubrication (JS61) Kanzaki Tuff Torq fully enclosed; grease lubrication (JS63 and JS63C)	Kanzaki Tuff Torq fully enclosed; grease lubrication
 Gear selection	N/A	N/A (JS60H) 1 Forward (JS61) 3 Forward (JS63 and JS63C)	3 Forward
Ground Speed	N/A	N/A (JS60H) 1st Gear – 3.9 kph (2.4 mph) (JS61) 1st Gear – 3.1 kph (1.9 mph) 2nd Gear – 3.9 kph (2.4 mph) 3rd Gear – 5.0 kph (3.1 mph) (JS63 and JS63C)	1st Gear – 3.1 kph (1.9 mph) 2nd Gear – 3.9 kph (2.4 mph) 3rd Gear – 5.0 kph (3.1 mph)

**DIMENSIONS**







Wheel Size	8.75 x 2.25	8.75 x 2.25	8.75 x 2.25
Weight (dry)	(34.0 kg) 75 lb - Push type	(34.0 kg) 75 lb (JS60H) (36.7 kg) 81 lb (JS61) (38.6 kg) 85 lb (JS63 and JS63C)	(38.6 kg) 85 lb
Cutting Width	53.34 cm (21 inches)	53.34 cm (21 inches)	53.34 cm (21 inches)
Cutting Height	2.5 – 10.2 cm (1 – 4 in.)	2.5 – 10.2 cm (1 – 4 in.)	2.5 – 10.2 cm (1 – 4 in.)

**TORQUE SPECIFICATIONS**

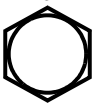
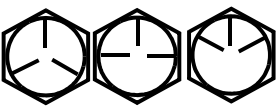
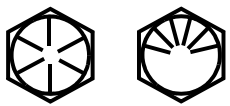
Blade Bolt	75 N•m (55 lb-ft)
Spark Plug	20 N•m (180 lb-in.)
Cylinder Head Cap Screw	16 N•m (140 lb-in.)
Flywheel Nut Torque	81 N•m (60 lb-ft)
Muffler Shoulder Bolts (6.0 HP Quantum engine)	10 N•m (89 lb-in.)
Muffler Bolts (6.5 HP Intek Engine)	10 N•m (89 lb-in.)
Muffler Cylinder Head Bolts (6.5 HP Intek Engine)	9.6 N•m (85 lb-in.)
Carburetor Mount	10 N•m (89 lb-in.)
Connecting Rod Cap Screw	11.3 N•m (100 lb-in.)
Crankcase Cover Cap Screw	10 N•m (89 lb-in.)
Engine to Mower Deck Cap Screws	40.7 ± 8 N•m (30 ± 6 lb-ft)
Wheel Mounting Nuts	28.5 N•m (21 lb-ft)
Axle Hubs to Rear Mower Deck Brackets	25.8 N•m (228 lb-in.)
Gearbox Bracket to Transaxle	
JS61	6.2 N•m (55 lb-in.)
JS63	7.5 N•m (66 lb-in.)
Cable Clip to Handlebar	8.1 N•m (72 lb-in.)

INCH FASTENER TORQUE VALUES



SAE Grade and Head Markings	1 or 2 <sup>b</sup> No Marks 	5 5.1 5.2 	8 8.2 
SAE Grade and Nut Markings	2 No Marks 	5  	8   TS1162

SIZE	Grade 1				Grade 2 <sup>b</sup>				Grade 5, 5.1 or 5.2				Grade 8 or 8.2			
	Lubricated <sup>a</sup>		Dry <sup>a</sup>		Lubricated <sup>a</sup>		Dry <sup>a</sup>		Lubricated <sup>a</sup>		Dry <sup>a</sup>		Lubricated <sup>a</sup>		Dry <sup>a</sup>	
	N•m	lb-ft	N•m	lb-ft	N•m	lb-ft	N•m	lb-ft	N•m	lb-ft	N•m	lb-ft	N•m	lb-ft	N•m	lb-ft
1/4	3.7	2.8	4.7	3.5	6	4.5	7.5	5.5	9.5	7	12	9	13.5	10	17	12.5
5/16	7.7	5.5	10	7	12	9	15	11	20	15	25	18	28	21	35	26
3/8	14	10	17	13	22	16	27	20	35	26	44	33	50	36	63	46
7/16	22	16	28	20	35	26	44	32	55	41	70	52	80	58	100	75
1/2	33	25	42	31	53	39	67	50	85	63	110	80	120	90	150	115
9/16	48	36	60	45	75	56	95	70	125	90	155	115	175	130	225	160
5/8	67	50	85	62	105	78	135	100	170	125	215	160	215	160	300	225
3/4	120	87	150	110	190	140	240	175	300	225	375	280	425	310	550	400
7/8	190	140	240	175	190	140	240	175	490	360	625	450	700	500	875	650
1	290	210	360	270	290	210	360	270	725	540	925	675	1050	750	1300	975
1-1/8	470	300	510	375	470	300	510	375	900	675	1150	850	1450	1075	1850	1350
1-1/4	570	425	725	530	570	425	725	530	1300	950	1650	1200	2050	1500	2600	1950
1-3/8	750	550	950	700	750	550	950	700	1700	1250	2150	1550	2700	2000	3400	2550
1-1/2	1000	725	1250	925	990	725	1250	930	2250	1650	2850	2100	3600	2650	4550	3350

DO NOT use these hand torque values if a different torque value or tightening procedure is given for a specific application. Torque values listed are for general use only and include a ±10% variance factor. Check tightness of fasteners periodically. DO NOT use air powered wrenches.

Shear bolts are designed to fail under predetermined loads. Always replace shear bolts with identical grade.

Fasteners should be replaced with the same grade. Make sure fastener threads are clean and that you properly start thread engagement. This will prevent them from failing when tightening.

When bolt and nut combination fasteners are used, torque values should be applied to the **NUT** instead of the bolt head.



Tighten toothed or serrated-type lock nuts to the full torque value.

<sup>a</sup> "Lubricated" means coated with a lubricant such as engine oil, or fasteners with phosphate and oil coatings. "Dry" means plain or zinc plated (yellow dichromate - Specification JDS117) without any lubrication.

<sup>b</sup> "Grade 2" applies for hex cap screws (not hex bolts) up to 152 mm (6-in.) long. "Grade 1" applies for hex cap screws over 152 mm (6-in.) long, and for all other types of bolts and screws of any length.

Reference: JDS—G200.

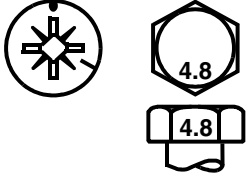
METRIC FASTENER TORQUE VALUES

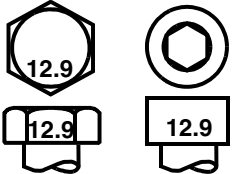
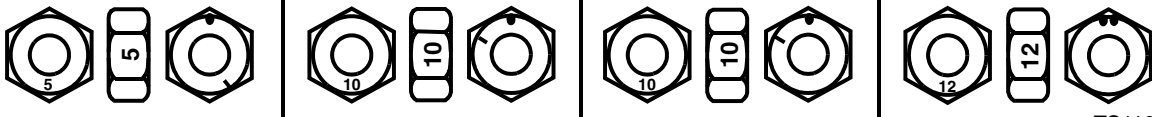
	<p>Property Class and Head Markings</p> 	<p>8.8 9.8</p> 	<p>10.9</p> 	<p>12.9</p> 
	<p>Property Class and Nut Markings</p> 	TS1163		

SIZE	Class 4.8				Class 8.8 or 9.8				Class 10.9				Class 12.9			
	Lubricated <sup>a</sup>		Dry <sup>a</sup>		Lubricated <sup>a</sup>		Dry <sup>a</sup>		Lubricated <sup>a</sup>		Dry <sup>a</sup>		Lubricated <sup>a</sup>		Dry <sup>a</sup>	
	N•m	lb-ft	N•m	lb-ft	N•m	lb-ft	N•m	lb-ft	N•m	lb-ft	N•m	lb-ft	N•m	lb-ft	N•m	lb-ft
M6	48	3.5	6	4.5	9	6.5	11	8.5	13	9.5	17	12	15	11.5	19	14.5
M8	12	8.5	15	11	22	16	28	20	32	24	40	30	37	28	47	35
M10	23	17	29	21	43	32	55	40	63	47	80	60	75	55	95	70
M12	40	29	50	37	75	55	95	70	110	80	140	105	130	95	165	120
M14	63	47	80	60	120	88	150	110	175	130	225	165	205	150	260	109
M16	100	73	125	92	190	140	240	175	275	200	350	225	320	240	400	300
M18	135	100	175	125	260	195	330	250	375	275	475	350	440	325	560	410
M20	190	140	240	180	375	275	475	350	530	400	675	500	625	460	800	580
M22	260	190	330	250	510	375	650	475	725	540	925	675	850	625	1075	800
M24	330	250	425	310	650	475	825	600	925	675	1150	850	1075	800	1350	1000
M27	490	360	625	450	950	700	1200	875	1350	1000	1700	1250	1600	1150	2000	1500
M30	675	490	850	625	1300	950	1650	1200	1850	1350	2300	1700	2150	1600	2700	2000
M33	900	675	1150	850	1750	1300	2200	1650	2500	1850	3150	2350	2900	2150	3700	2750
M36	1150	850	1450	1075	2250	1650	2850	2100	3200	2350	4050	3000	3750	2750	4750	3500

DO NOT use these hand torque values if a different torque value or tightening procedure is given for a specific application. Torque values listed are for general use only and include a ±10% variance factor. Check tightness of fasteners periodically. DO NOT use air powered wrenches.

Shear bolts are designed to fail under predetermined loads. Always replace shear bolts with identical grade.

Fasteners should be replaced with the same grade. Make sure fastener threads are clean and that you properly start thread engagement. This will prevent them from failing when tightening.

When bolt and nut combination fasteners are used, torque values should be applied to the **NUT** instead of the bolt head.

Tighten toothed or serrated-type lock nuts to the full torque value.

<sup>a</sup> "Lubricated" means coated with a lubricant such as engine oil, or fasteners with phosphate and oil coatings. "Dry" means plain or zinc plated (yellow dichromate - Specification JDS117) without any lubrication.

Reference: JDS—G200.

# GASOLINE

## CAUTION

Gasoline is **HIGHLY FLAMMABLE**, handle it with care.

**DO NOT** refuel machine while:

- indoors, always fill gas tank outdoors;
- machine is near an open flame or sparks;
- engine is running, **STOP** engine;
- engine is hot, allow it to cool sufficiently first;
- smoking.

Help prevent fires:

- fill gas tank to bottom of filler neck only;
- be sure fill cap is tight after fueling;
- clean up any gas spills **IMMEDIATELY**;
- keep machine clean and in good repair—free of excess grease, oil, debris, and faulty or damaged parts;
- any storage of machines with gas left in tank should be in an area that is well ventilated to prevent possible igniting of fumes by an open flame or spark, this includes any appliance with a pilot light.

To prevent fire or explosion caused by **STATIC ELECTRIC DISCHARGE** during fueling:

- **ONLY** use a clean, approved **POLYETHYLENE PLASTIC** fuel container and funnel **WITHOUT** any metal screen or filter.

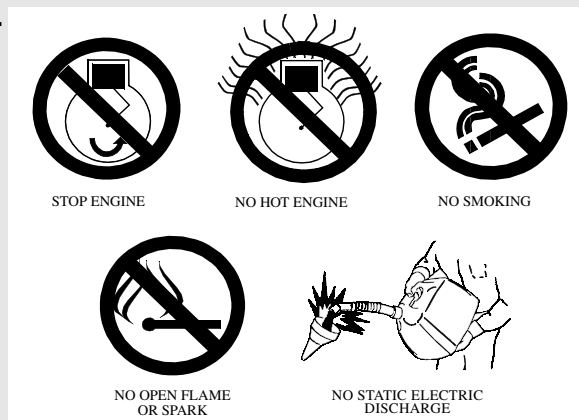

To avoid engine damage:

- DO NOT mix oil with gasoline;
- **ONLY** use clean, fresh unleaded gasoline with an octane rating (anti-knock index) of 87 or higher;
- fill gas tank at the end of each day's operation to help prevent condensation from forming inside a partially filled tank;
- keep up with specified service intervals.

Use of alternative oxygenated, gasohol blended, unleaded gasoline is acceptable as long as:

- the ethyl or grain alcohol blends DO NOT exceed 10% by volume or
- methyl tertiary butyl ether (MTBE) blends DO NOT exceed 15% by volume.



**IMPORTANT: DO NOT** use **METHANOL** gasoline because **METHANOL** is harmful to the environment and to your health.

## WARNING

**California Proposition 65 Warning:** Gasoline engine exhaust from this product contains chemicals known to the State of California to cause cancer, birth defects, or other reproductive harm.

## GASOLINE STORAGE

**IMPORTANT:** Keep all dirt, scale, water or other foreign material out of gasoline.

Keep gasoline stored in a safe, protected area. Storage of gasoline in a clean, properly marked (“**UNLEADED GASOLINE**”) **POLYETHYLENE PLASTIC** container **WITHOUT** any metal screen or filter is recommended. **DO NOT** use de-icers to attempt to remove water from gasoline or depend on fuel filters to remove water from gasoline. Use a water separator installed in the storage tank outlet. **BE SURE** to properly discard unstable or contaminated gasoline. When storing unit or gasoline, it is recommended that you add **John Deere Gasoline Conditioner and Stabilizer (TY15977)** or an equivalent to the gasoline. **BE SURE** to follow directions on container and to properly discard empty container.

## ENGINE OIL

Use the appropriate oil viscosity based on the expected air temperature range during the period between recommended oil changes. Operating outside of these recommended oil air temperature ranges may cause premature engine failure.



The following John Deere oil is **PREFERRED**:

- **TORQ-GARD SUPREME®—SAE 5W-30;**
- **UNI-GARD™—SAE 5W-30.**

The following John Deere oils are **also recommended**, based on their specified temperature range:

- **TURF-GARD®—SAE 10W-30;**
- **PLUS-4®—SAE 10W-30;**
- **TORQ-GARD SUPREME®—SAE 30;**
- **TORQ-GARD SUPREME®—SAE 10W-30;**
- **UNI-GARD™—SAE 10W-30;**
- **UNI-GARD™—SAE 30.**

Other oils may be used if above John Deere oils are not available, provided they meet one of the following specifications:

- SAE 5W-30—API Service Classification SG or higher;
- SAE 10W-30—API Service Classification SG or higher;
- SAE 30—API Service Classification SC or higher.

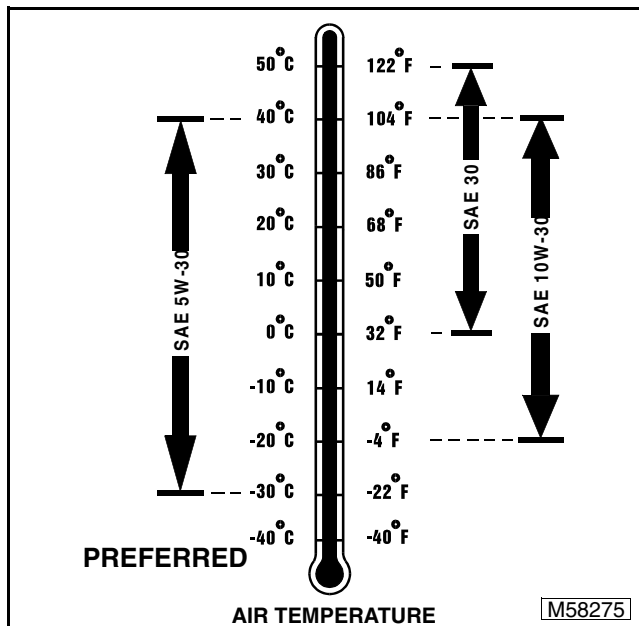

**John Deere Dealers:** You may want to cross-reference the following publications to recommend the proper oil for your customers:

- Module DX, ENOIL2 in JDS-G135;
- Section 530, Lubricants and Hydraulics, of the John Deere Merchandise Sales Guide;
- Lubrication Sales Manual PI7032.

## ENGINE BREAK-IN OIL

**IMPORTANT:** ONLY use a quality break-in oil in rebuilt or remanufactured engines for the **first 5 hours (maximum) of operation**. DO NOT use oils with heavier viscosity weights than SAE 5W-30 or oils meeting specifications API SG or SH, these oils will not allow rebuilt or remanufactured engines to break-in properly.

The following John Deere oil is **PREFERRED**:

- **John Deere BREAK-IN ENGINE OIL.**

**John Deere BREAK-IN ENGINE OIL** is formulated with special additives for aluminum and cast iron type engines to allow the power cylinder components (pistons, rings, and liners as well) to “wear-in” while protecting other engine components, valve train and gears, from abnormal wear. Engine rebuild instructions should be followed closely to determine if special requirements are necessary.

**John Deere BREAK-IN ENGINE OIL** is also recommended for non-John Deere engines, both aluminum and cast iron types.

The following John Deere oil is **also recommended** as a break-in engine oil:

- **TORQ-GARD SUPREME®—SAE 5W-30.**

If the above recommended John Deere oils are not available, use a break-in engine oil meeting the following specification during the first 5 hours (maximum) of operation:

- SAE 5W-30—API Service Classification SE or higher.
- SAE 5W-30—CCMC Specification G4 or higher.

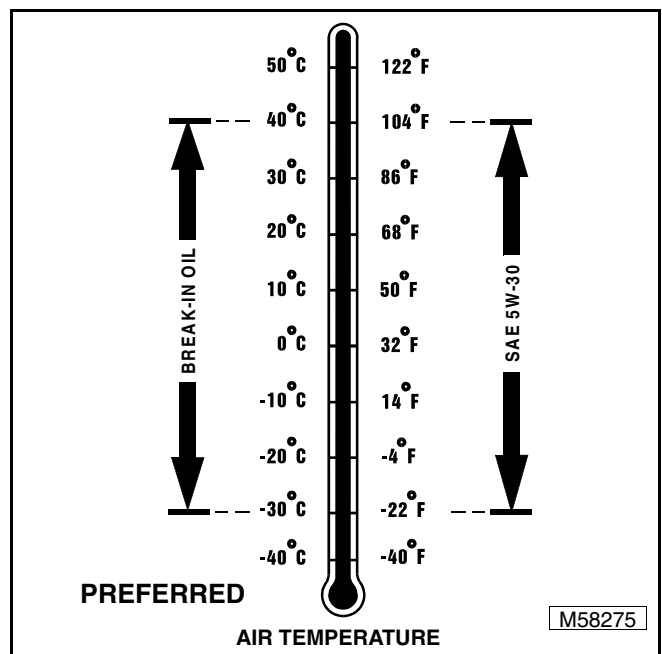

**IMPORTANT:** After the break-in period, use the John Deere oil that is recommended for this engine.

**John Deere Dealers:** You may want to cross-reference the following publications to recommend the proper oil for your customers:

- Module DX, ENOIL4 in JDS-G135;
- Section 530, Lubricants and Hydraulics, of the John Deere Merchandise Sales Guide;
- Lubrication Sales Manual PI7032.

## LUBRICANTS

### ANTI-CORROSION GREASE

This anti-corrosion grease is formulated to provide the best protection against absorbing moisture, which is one of the major causes of corrosion. This grease is also superior in its resistance to separation and migration.

The following anti-corrosion grease is **PREFERRED**:

- **DuBois MPG-2® Multi-Purpose Polymer Grease—M79292.**

Other greases may be used if they meet or exceed the following specifications:

- John Deere Standard JDM J13A2, NLGI Grade 1.

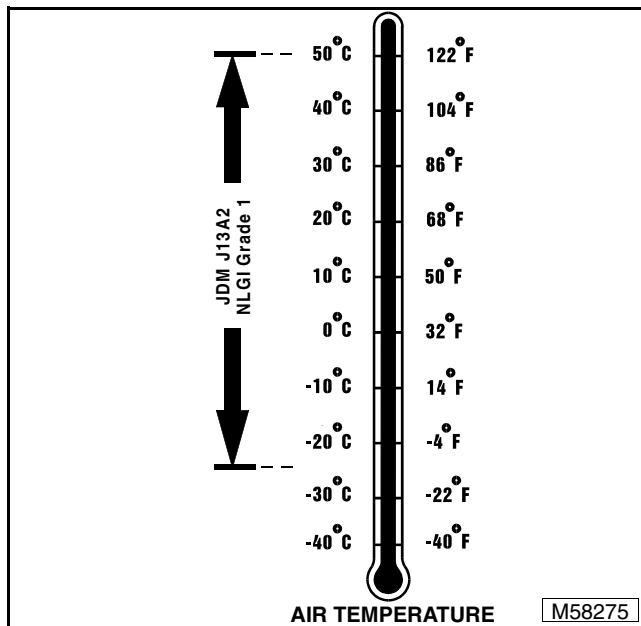

**John Deere Dealers:** You may want to cross-reference the following publications to recommend the proper grease for your customers:

- Module DX, GREAA1 in JDS-G135;
- Section 530, Lubricants and Hydraulics, of the John Deere Merchandise Sales Guide;
- Lubrication Sales Manual PI7032.

### CHASSIS GREASE

Use the following grease based on the air temperature range. Operating outside of the recommended grease air temperature range may cause premature failures.

**IMPORTANT:** ONLY use a quality grease in this application. DO NOT mix any other greases in this application. DO NOT use any BIO-GREASE in this application.



The following John Deere grease is **PREFERRED**:

- **HIGH-TEMPERATURE EP GREASE®—JDM J13E4, NLGI Grade 2.**
- **GREASE-GARD™—JDM J13E4, NLGI Grade 2.**

Other greases may be used if above preferred John Deere grease is not available, provided they meet the following specification:

- John Deere Standard JDM J13E4, NLGI Grade 2.

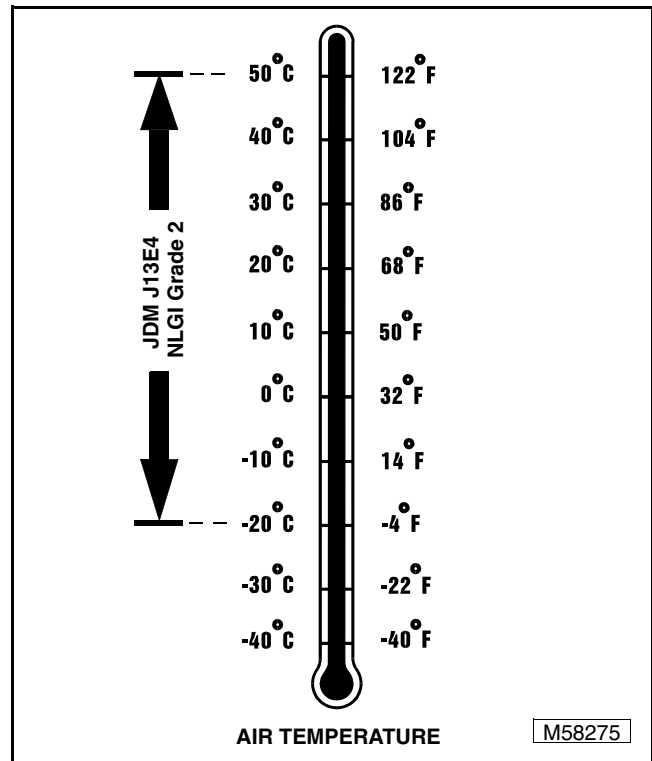

**John Deere Dealers:** You may want to cross-reference the following publications to recommend the proper grease for your customers:

- Module DX, GREAA1 in JDS-G135;
- Section 530, Lubricants and Hydraulics, of the John Deere Merchandise Sales Guide;
- Lubrication Sales Manual P17032.

## ALTERNATIVE LUBRICANTS

Conditions in certain geographical areas outside the United States and Canada may require different lubricant recommendations than the ones printed in this technical manual or the operator's manual. Consult with your John Deere Dealer, or Sales Branch, to obtain the alternative lubricant recommendations.

**IMPORTANT:** Use of alternative lubricants could cause reduced life of the component.

If alternative lubricants are to be used, it is recommended that the factory fill be thoroughly removed before switching to any alternative lubricant.

## SYNTHETIC LUBRICANTS

Synthetic lubricants may be used in John Deere equipment if they meet the applicable performance requirements (industry classification and/or military specification) as shown in this manual.

The recommended air temperature limits and service or lubricant change intervals should be maintained as shown in the operator's manual.

Avoid mixing different brands, grades, or types of oil. Oil manufacturers blend additives in their oils to meet certain specifications and performance requirements. Mixing different oils can interfere with the proper functioning of these additives and degrade lubricant performance.

## LUBRICANT STORAGE

All machines operate at top efficiency only when clean lubricants are used. Use clean storage containers to handle all lubricants. Store them in an area protected from dust, moisture, and other contamination. Store drums on their sides. Make sure all containers are properly marked as to their contents. Dispose of all old, used containers and their contents properly.

## MIXING OF LUBRICANTS

In general, avoid mixing different brands or types of lubricants. Manufacturers blend additives in their lubricants to meet certain specifications and performance requirements. Mixing different lubricants can interfere with the proper functioning of these additives and lubricant properties which will downgrade their intended specified performance.

## PRODUCT IDENTIFICATION LOCATIONS

When ordering parts or submitting a warranty claim, it is **IMPORTANT** that you include the product identification number and the component product identification numbers.

The location of identification numbers and component product identification numbers are shown.

### PRODUCT IDENTIFICATION NUMBER



### ENGINE (6.0 HP B&S Quantum Engine Shown)

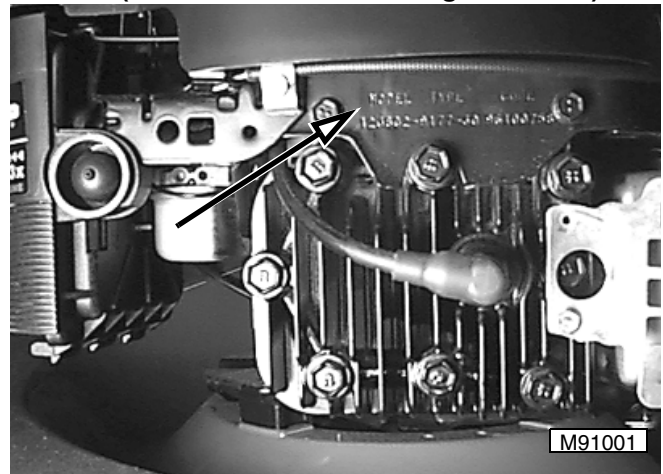

### TRANSAXLE PIN (1 SPEED SHOWN)

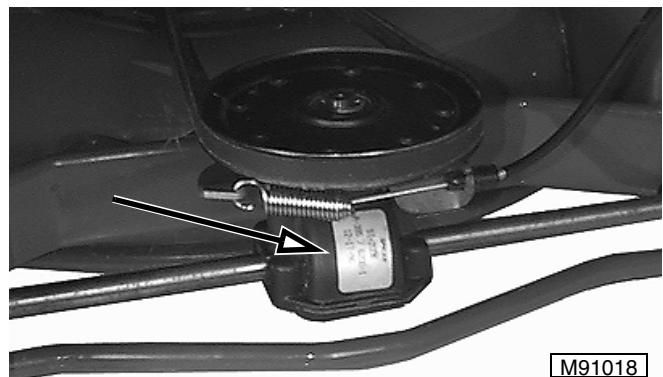

# CONTENTS

	Page
<b>SPECIFICATIONS</b> .....	<b>3</b>
ENGINE SPECIFICATIONS .....	3
FUEL .....	3
ELECTRICAL SPECIFICATIONS .....	3
REPAIR SPECIFICATIONS .....	3
TORQUE SPECIFICATIONS .....	4
SPECIAL EQUIPMENT OR TOOLS .....	4
OTHER MATERIALS .....	5
<b>COMPONENT LOCATION</b> .....	<b>6</b>
COMPONENT LOCATION—ENGINE .....	6
COMPONENT LOCATION—CARBURETOR .....	7
<b>TROUBLESHOOTING</b> .....	<b>8</b>
ENGINE TROUBLESHOOTING CHART .....	8
CARBURETION TROUBLESHOOTING CHART .....	9
ENGINE TROUBLESHOOTING GUIDE .....	10
<b>THEORY OF OPERATION</b> .....	<b>12</b>
COOLING SYSTEM .....	12
CRANKCASE BREATHER SYSTEM .....	12
LUBRICATION SYSTEM .....	12
COMPRESSION RELEASE SYSTEM .....	12
FUEL SYSTEM .....	12
CARBURETOR PRIMER CIRCUIT OPERATION .....	13
CARBURETOR MAIN CIRCUIT OPERATION .....	14
AIR INTAKE SYSTEM OPERATION .....	15
GOVERNOR OPERATION .....	16
FLYWHEEL BRAKE OPERATION .....	17
IGNITION CIRCUIT OPERATION .....	18
<b>DIAGNOSIS</b> .....	<b>19</b>
ENGINE TURNS OVER BUT WILL NOT START .....	19
ENGINE STARTS, THEN STOPS, OR STOPS WHEN HOT .....	19
ENGINE USES TOO MUCH OIL OR BLUE EXHAUST SMOKE .....	20
BLACK EXHAUST SMOKE OR ENGINE FLOODING .....	20
ENGINE MISSES OR SPRAYS FUEL OUT OF CARBURETOR INLET .....	21
ENGINE SURGES .....	21
<b>TESTS AND ADJUSTMENTS</b> .....	<b>22</b>
AUTOMATIC COMPRESSION RELEASE (ACR) TEST .....	22
CYLINDER LEAK-DOWN TEST .....	22
CRANKCASE VACUUM TEST .....	23
VALVE CLEARANCE CHECK .....	24
GOVERNOR ADJUSTMENT .....	24
ENGINE IDLE ADJUSTMENT .....	25
SPARK TEST .....	26
IGNITION AIR GAP ADJUSTMENT .....	26
FLYWHEEL KEY INSPECTION .....	26
CARBURETOR ADJUSTMENT .....	27



	Page
<b>REPAIR .....</b>	<b>27</b>
CARBURETOR REMOVAL .....	27
CARBURETOR INSPECTION .....	28
MUFFLER REMOVAL AND INSTALLATION .....	28
ENGINE COVER REMOVAL .....	29
FUEL TANK REMOVAL .....	29
ENGINE BLOWER HOUSING REMOVAL .....	30
ENGINE BLOWER HOUSING INSTALLATION .....	30
CYLINDER HEAD REMOVAL .....	30
CYLINDER HEAD INSTALLATION .....	30
CYLINDER HEAD INSPECTION .....	31
CRANKCASE BREATHER REMOVAL AND INSPECTION .....	31
CRANKCASE BREATHER INSTALLATION .....	32
VALVE REMOVAL AND INSTALLATION .....	32
FLYWHEEL BRAKE CABLE REMOVAL AND INSTALLATION .....	32
ENGINE REMOVAL AND INSTALLATION .....	33
CRANKCASE COVER REMOVAL .....	34
CAMSHAFT INSPECTION .....	35
CRANKCASE COVER INSTALLATION .....	35
GOVERNOR LEVER REMOVAL AND INSTALLATION .....	36
FLYWHEEL REMOVAL AND INSTALLATION .....	36
PISTON REMOVAL AND DISASSEMBLY .....	37
PISTON ASSEMBLY AND INSTALLATION .....	37
CONNECTING ROD INSPECTION .....	38
CYLINDER BORE MEASUREMENT .....	38
CRANKSHAFT REMOVAL AND INSTALLATION .....	39
MAGNETO BEARING REMOVAL AND INSTALLATION .....	39
VALVE SEAT RECONDITIONING .....	39
VALVE FACE RECONDITIONING .....	41
VALVE SEAT REPLACEMENT .....	41
EXHAUST VALVE GUIDE REPLACEMENT .....	42
RECOIL STARTER REMOVAL AND INSTALLATION .....	43
RECOIL STARTER INSPECTION .....	43



## SPECIFICATIONS

### ENGINE SPECIFICATIONS

Manufacturer	Briggs & Stratton
Model	12H802
Cycle	Air cooled (4 cycle)
Valve Type	Side
Horsepower@	6 hp (4.5 kW) @3600 RPM
Displacement	190 cc (11.6 cu in.)
Fixed No-Load Speed	3200 ± 100 RPM
Cylinder Bore (Nominal)	68.263 mm (2.6875 in.)
Stroke	51.80 mm (2.040 in.)
Lubrication Type	Splash System
Oil capacity	0.5 L (16 U.S. oz)
Oil fill	Top/left of engine



### FUEL

Type required	Unleaded Gasoline, 87 Octane
Fuel tank capacity	1.5 L (1.6 U.S. qt)
Carburetor	Float-type with primer
Fuel filter	N/A

### ELECTRICAL SPECIFICATIONS

Ignition	Electronic
Spark plug (resistor)	RCJ8 Champion
Starting	Recoil with compression release standard on all models.
Armature Air Gap	.015 – 0.25 mm (0.006 – 0.010 in.)
Spark Plug Gap	.0071 – 0.084 mm (0.028 – 0.033 in.)

### REPAIR SPECIFICATIONS

#### Connecting Rod:

Crankpin Bore (ID)	.27.95 – 27.93 mm (1.100 – 1.010 in.)
Crankpin Bore (Reject Size)	.27.98 mm (1.102 in.)
Piston Pin Bore (ID)	.15.89 – 15.90 mm (0.626 – 0.626 in.)

#### Crankshaft Journals:

Main Bearing ID (Maximum)	.22.43 mm (0.883 in.)
Out-of Round (Maximum)	.0013 mm (0.001 in.)
PTO End (Reject Size)	.26.92 mm (1.060 in.)
Crankpin (Reject Size)	.27.86 mm (1.097 in.)
Flywheel End (Reject Size)	.22.17 mm (0.873 in.)
Crankshaft End Play	.005 – 0.76 mm (0.002 – 0.030 in.)

#### Camshaft:

Gear Journal (Reject Size)	.12.65 mm (0.498 in.)
Lobes	Replace if lobes are pitted or galled

**Cylinder Bore:**

Bore ID (Reject Size Maximum) .....68.29 mm (2.689 in.)

**Piston Pin:**

Pin Diameter (Reject Size) .....15.85 mm (0.624 in.)

Bearing Bore (Maximum) .....15.90 mm (0.626 in.)

**Valve Clearance:**

Intake .....0.10 – 0.20 mm (0.004 – 0.008 in.)

Exhaust .....0.15 – 0.25 mm (0.006 – 0.010 in.)

**Valve Seats:**

Exhaust Angle ..... 46°

Intake Angle ..... 31°

Minimum Width .....0.79 mm (0.031 in.)

**Piston Rings End Gap:**

Compression Rings (Reject Size) .....0.89 mm (0.035 in.)

Oil Ring (Reject Size) .....1.14 mm (0.045 in.)

**TORQUE SPECIFICATIONS**

Spark Plug ..... 20 N•m (180 lb-in.)

Cylinder Head Cap Screw ..... 16 N•m (140 lb-in.)

Flywheel Nut ..... 81 N•m (60 lb-ft)

Muffler Shoulder Bolt ..... 10 N•m (89 lb-in.)

Carburetor Mount ..... 10 N•m (89 lb-in.)

Intake Manifold Cap Screw .....13.5 N•m (120 lb-in.)

Connecting Rod Cap Screw .....11.3 N•m (100 lb-in.)

Crankcase Cover Cap Screw ..... 10 N•m (89 lb-in.)

Engine to Mower Deck Cap Screws ..... 40.7 ± 8 N•m (30 ± 6 lb-ft)

Mower Blade Bolt ..... 75 N•m (55 lb-ft)

**SPECIAL EQUIPMENT OR TOOLS**

- JDM59 Pressure Gauge
- JT03503 Vacuum Gauge
- 8741-F66 Plug
- JT05703 Barb Fitting
- JT05699 Line
- D-05351ST Spark Tester
- JT07270 Digital Pulse Tachometer
- JDM46-12 Flywheel Holder (Recommended)
- JDM52A Valve Seat Service Set



**Suggest:**

**If the above button click is invalid.**

**Please download this document**

**first, and then click the above link**

**to download the complete manual.**

**Thank you so much for reading**

---



---

**OTHER MATERIALS**

<b>Number</b>	<b>Name</b>	<b>Use</b>
M79292	MPG-2 <sup>®</sup> Multipurpose Grease	Apply to engine crankshaft
	SCOTCH-BRITE <sup>®</sup> Abrasive Sheets/Pads	Clean cylinder head
	Lithium Base Grease	Pack oil seals
	Mineral Spirits	Clean armature
T43512 / TY9473 / LOCTITE <sup>®</sup> 242	Thread Lock and Sealer (Medium Strength)	Apply to threads of governor shaft and blade bolt

MPG-2<sup>®</sup> is a registered trademark of DuBois USA.  
 SCOTCH-BRITE<sup>®</sup> is a registered trademark of the 3M Co.  
 LOCTITE<sup>®</sup> is a registered trademark of the Loctite Corp.



**<https://www.ebooklibonline.com>**

Hello dear friend!

Thank you very much for reading.

Enter the link into your browser.

The full manual is available for immediate download.

**<https://www.ebooklibonline.com>**