

GT242, GT262, and GT275 Lawn and Garden Tractors



TECHNICAL MANUAL

**John Deere
Worldwide Commercial and
Consumer Equipment Division
TM1582 (15JUL97)
Replaces TM1582 (22DEC94)
and TM1515 (01SEPT92)**



M85682

Model GT242



M85683

Model GT262



M85684

Model GT275

This technical manual is written for an experienced technician and contains sections that are specifically for this product. It is a part of a total product support program.









The manual is organized so that all the information on a particular system is kept together. The order of grouping is as follows:

- Table of Contents
- General Diagnostic Information
- Specifications
- Electrical Wiring Harness Legend
- Component Location
- System Schematic
- Wiring Harness
- Troubleshooting Chart
- Theory of Operation
- Diagnostics
- Tests & Adjustments
- Repair

NOTE: Depending on the particular section or system being covered, not all of the above groups may be used.

Each section will be identified with a symbol rather than a number. The groups and pages within a section will be consecutively numbered.

We appreciate your input on this manual. To help, there are postage paid post cards included at the back. If you find any errors or want to comment on the layout of the manual please fill out one of the cards and mail it back to us.

Safety	
Specifications and Information	
Engine (FV420V, FV540V)	
Electrical	
Gear Power Train	
Hydrostatic Power Train	
Steering	
Brakes	
Attachments	
Miscellaneous	M

All information, illustrations and specifications in this manual are based on the latest information available at the time of publication. The right is reserved to make changes at any time without notice.

COPYRIGHT© 1997
 Deere & Co.
 John Deere Worldwide Commercial and
 Consumer Equipment Division
 Horicon, WI
 All rights reserved
 Previous Editions
 COPYRIGHT© 1996, 1995, 1994, 1992,
 1991, 1990, 1989, and 1988

<https://www.ebooklibonline.com>

Hello dear friend!

Thank you very much for reading.

Enter the link into your browser.

The full manual is available for immediate download.

<https://www.ebooklibonline.com>



RECOGNIZE SAFETY INFORMATION



This is the safety-alert symbol. When you see this symbol on your machine or in this manual, be alert to the potential for personal injury.

Follow recommended precautions and safe servicing practices.

Understand Signal Words

A signal word—DANGER, WARNING, or CAUTION—is used with the safety-alert symbol. DANGER identifies the most serious hazards.

DANGER or WARNING safety signs are located near specific hazards. General precautions are listed on CAUTION safety signs. CAUTION also calls attention to safety messages in this manual.

REPLACE SAFETY SIGNS

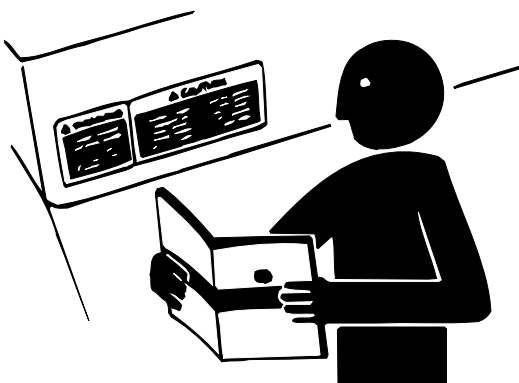

Replace missing or damaged safety signs. See the machine operator's manual for correct safety sign placement.

HANDLE FLUIDS SAFELY-AVOID FIRES

Be Prepared For Emergencies

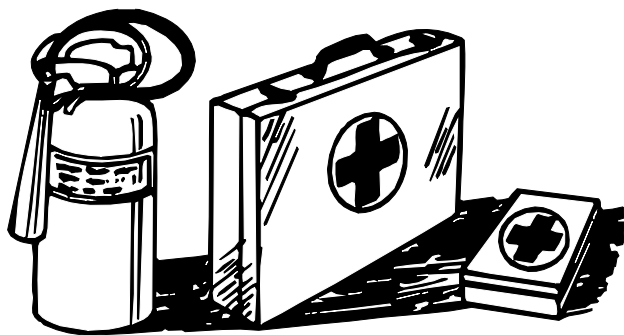

When you work around fuel, do not smoke or work near heaters or other fire hazards. Store flammable fluids away from fire hazards. Do not incinerate or puncture pressurized containers. Make sure machine is clean of trash, grease, and debris. Do not store oily rags; they can ignite and burn spontaneously. Be prepared if a fire starts. Keep a first aid kit and fire extinguisher handy. Keep emergency numbers for doctors, ambulance service, hospital, and fire department near your telephone.

USE CARE IN HANDLING AND SERVICING BATTERIES

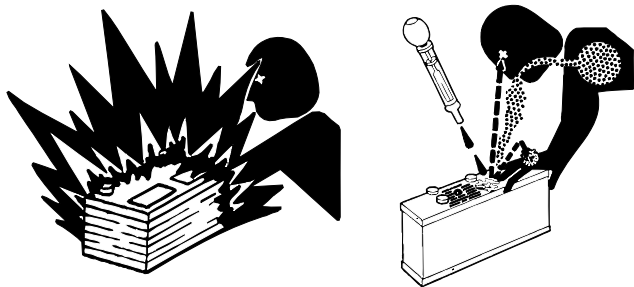

Prevent Battery Explosions

- Keep sparks, lighted matches, and open flame away from the top of battery. Battery gas can explode.
- Never check battery charge by placing a metal object across the posts. Use a volt-meter or hydrometer.
- Do not charge a frozen battery; it may explode. Warm battery to 16°C (60°F).

Prevent Acid Burns

- Sulfuric acid in battery electrolyte is poisonous. It is strong enough to burn skin, eat holes in clothing, and cause blindness if splashed into eyes.
- **Avoid acid burns by:**
 1. Filling batteries in a well-ventilated area.
 2. Wearing eye protection and rubber gloves.
 3. Avoiding breathing fumes when electrolyte is added.
 4. Avoiding spilling or dripping electrolyte.
 5. Use proper jump start procedure.
- **If you spill acid on yourself:**
 1. Flush your skin with water.
 2. Apply baking soda or lime to help neutralize the acid.
 3. Flush your eyes with water for 10–15 minutes.
 4. Get medical attention immediately.
- **If acid is swallowed:**
 1. Drink large amounts of water or milk.
 2. Then drink milk of magnesia, beaten eggs, or vegetable oil.
 3. Get medical attention immediately.

USE SAFE SERVICE PROCEDURES

Wear Protective Clothing

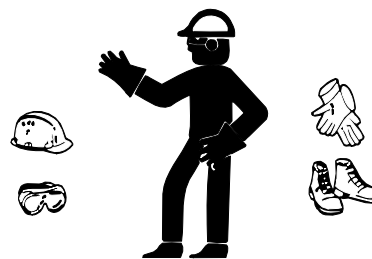

Wear close fitting clothing and safety equipment appropriate to the job.

Prolonged exposure to loud noise can cause impairment or loss of hearing. Wear a suitable hearing protective device such as earmuffs or earplugs to protect against objectionable or uncomfortable loud noises. Operating equipment safely requires the full attention of the operator. Do not wear radio or music headphones while operating machine.

Service Machines Safely

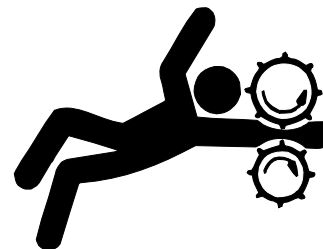

Tie long hair behind your head. Do not wear a necktie, scarf, loose clothing, or necklace when you work near machine tools or moving parts. If these items were to get caught, severe injury could result. Remove rings and other jewelry to prevent electrical shorts and entanglement in moving parts.

Use Proper Tools

Use tools appropriate to the work. Makeshift tools and procedures can create safety hazards. Use power tools only to loosen threaded parts and fasteners. For loosening and tightening hardware, use the correct size tools. **DO NOT** use U.S. measurement tools on metric fasteners. Avoid bodily injury caused by slipping wrenches. Use only service parts meeting John Deere specifications.



Park Machine Safely

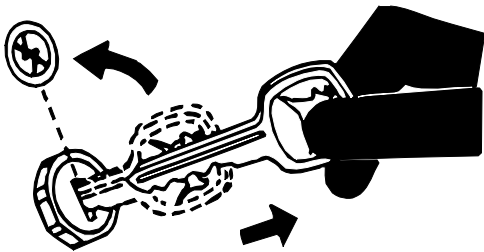

Before working on the machine:

1. Lower all equipment to the ground.
2. Stop the engine and remove the key.
3. Disconnect the battery ground strap.
4. Hang a "DO NOT OPERATE" tag in operator station.

Support Machine Properly And Use Proper Lifting Equipment

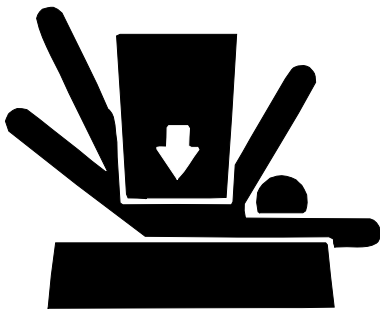

If you must work on a lifted machine or attachment, securely support the machine or attachment. Do not support the machine on cinder blocks, hollow tiles, or props that may crumble under continuous load. Do not work under a machine that is supported solely by a jack. Follow recommended procedures in this manual. Lifting heavy components incorrectly can cause severe injury or machine damage. Follow recommended procedure for removal and installation of components in the manual.

Work In Clean Area

Before starting a job:

1. Clean work area and machine.
2. Make sure you have all necessary tools to do your job.
3. Have the right parts on hand.
4. Read all instructions thoroughly; do not attempt shortcuts.

Illuminate Work Area Safely

Illuminate your work area adequately but safely. Use a portable safety light for working inside or under the machine. Make sure the bulb is enclosed by a wire cage. The hot filament of an accidentally broken bulb can ignite spilled fuel or oil.

Work In Ventilated Area

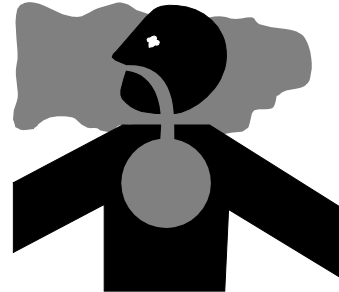

Engine exhaust fumes can cause sickness or death. If it is necessary to run an engine in an enclosed area, remove the exhaust fumes from the area with an exhaust pipe extension.

If you do not have an exhaust pipe extension, open the doors and get outside air into the area.

WARNING: California Proposition 65 Warning

Gasoline engine exhaust from this product contains chemicals known to the State of California to cause cancer, birth defects, or other reproductive harm.

Remove Paint Before Welding Or Heating

Avoid potentially toxic fumes and dust. Hazardous fumes can be generated when paint is heated by welding, soldering, or using a torch. Do all work outside or in a well ventilated area. Dispose of paint and solvent properly. Remove paint before welding or heating: If you sand or grind paint, avoid breathing the dust. Wear an approved respirator. If you use solvent or paint stripper, remove stripper with soap and water before welding. Remove solvent or paint stripper containers and other flammable material from area. Allow fumes to disperse at least 15 minutes before welding or heating.

Avoid Harmful Asbestos Dust

Avoid breathing dust that may be generated when handling components containing asbestos fibers. Inhaled asbestos fibers may cause lung cancer.

Components in products that may contain asbestos fibers are brake pads, brake band and lining assemblies, clutch plates, and some gaskets. The asbestos used in these components is usually found in a resin or sealed in some way. Normal handling is not hazardous as long as airborne dust containing asbestos is not generated. Avoid creating dust. Never use compressed air for cleaning. Avoid brushing or grinding material containing asbestos. When servicing, wear an approved respirator. A special vacuum cleaner is recommended to clean asbestos. If not available, apply a mist of oil or water on the material containing asbestos. Keep bystanders away from the area.

SERVICE TIRES SAFELY



Explosive separation of a tire and rim parts can cause serious injury or death.

Do not attempt to mount a tire unless you have the proper equipment and experience to perform the job. Always maintain the correct tire pressure. Do not inflate the tires above the recommended pressure. Never weld or heat a wheel and tire assembly. The heat can cause an increase in air pressure resulting in a tire explosion. Welding can structurally weaken or deform the wheel.

When inflating tires, use a clip-on chuck and extension hose long enough to allow you to stand to one side and NOT in front of or over the tire assembly. Use a safety cage if available.

Check wheels for low pressure, cuts, bubbles, damaged rims or missing lug bolts and nuts.

AVOID INJURY FROM ROTATING BLADES, AUGERS AND PTO SHAFTS

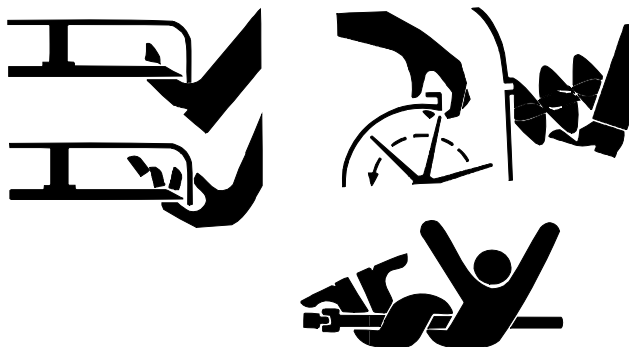

Keep hands and feet away while machine is running. Shut off power to service, lubricate or remove mower blades, augers or PTO shafts.

HANDLE CHEMICAL PRODUCTS SAFELY

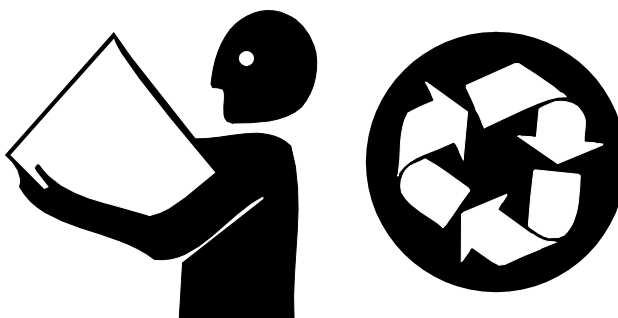

Direct exposure to hazardous chemicals can cause serious injury. Potentially hazardous chemicals used with John Deere equipment include such items as lubricants, coolants, paints, and adhesives.

A Material Safety Data Sheet (MSDS) provides specific details on chemical products: physical and health hazards, safety procedures, and emergency response techniques. Check the MSDS before you start any job using a hazardous chemical. That way you will know exactly what the risks are and how to do the job safely. Then follow procedures and recommended equipment.



Dispose of Waste Properly

Improperly disposing of waste can threaten the environment and ecology. Potentially harmful waste used with John Deere equipment include such items as oil, fuel, coolant, brake fluid, filters, and batteries. Use leakproof containers when draining fluids. Do not use food or beverage containers that may mislead someone into drinking from them. Do not pour waste onto the ground, down a drain, or into any water source. Inquire on the proper way to recycle or dispose of waste from your local environmental or recycling center, or from your John Deere dealer.

LIVE WITH SAFETY



Before returning machine to customer, make sure machine is functioning properly, especially the safety systems. Install all guards and shields.

CONTENTS

Page



GENERAL VEHICLE SPECIFICATIONS	2-2
TORQUE VALUES, NON-STANDARD FASTENERS	2-7
ENGINE	2-7
POWER TRAIN, GEAR	2-8
POWER TRAIN, HYDROSTATIC	2-8
OTHER	2-8
METRIC FASTENER TORQUE VALUES	2-10
METRIC FASTENER TORQUE VALUE – GRADE 7	2-11
INCH FASTENER TORQUE VALUES	2-12
GASOLINE SPECIFICATIONS	2-13
4-CYCLE ENGINES – NORTH AMERICA	2-13
GASOLINE STORAGE	2-13
ENGINE OIL SPECIFICATIONS	2-14
4-CYCLE GASOLINE ENGINE OIL –NORTH AMERICA	2-14
BREAK-IN 4-CYCLE GASOLINE ENGINE OIL – NORTH AMERICA	2-15
HYDROSTATIC TRANSMISSION AND HYDRAULIC OIL	2-16
ANTI-CORROSION GREASE SPECIFICATIONS	2-17
GENERAL APPLICATION GREASE SPECIFICATIONS	2-18
GREASE – NORTH AMERICA	2-18
ALTERNATIVE LUBRICANTS	2-19
SYNTHETIC LUBRICANTS	2-19
LUBRICANT STORAGE	2-19
MIXING OF LUBRICANTS	2-19
OIL FILTERS	2-19
SERIAL NUMBER LOCATION	2-20
MACHINE IDENTIFICATION NUMBER	2-20
ENGINE SERIAL NUMBER	2-20
CARBURETOR SERIAL NUMBER	2-20
GEAR TRANSAXLE SERIAL NUMBER LOCATION	2-20
HYDROSTATIC TRANSMISSION SERIAL NUMBER	2-20
MOWER DECK SERIAL NUMBER LOCATION	2-21

GENERAL VEHICLE SPECIFICATIONS

Model:	GT242	GT262	GT275
 ENGINE			
Make	John Deere "K" Series, Air Cooled	John Deere "K" Series, Air Cooled	John Deere "K" Series, Air Cooled
Manufacturer	Kawasaki	Kawasaki	Kawasaki
Type	Gasoline	Gasoline	Gasoline
Model	FC420V-ES10	FC540V-ES15	FV540V-KS00
Aspiration	Natural	Natural	Natural
Horsepower	10.4 kW (14 HP)	12.6 kW (17 HP)	12.6 kW (17 HP)
Cylinders	1	1	1
Displacement	423 cm ³ (25.8 cu. in.)	535cm ³ (32.6 cu. in.)	535 cm ³ (32.6 cu. in.)
Stroke/Cycle	4 Cycle	4 Cycle	4 Cycle
Bore	89 mm (3.500 in.)	89 mm (3.500 in.)	89 mm (3.500 in.)
Stroke	68 mm (2.58 in.)	86 mm (3.360 in.)	86 mm (3.360 in.)
Compression Ratio		8.3:1	8.3:1
Slow Idle	1550 ± 75 rpm	1550 ± 75 rpm	1550 ± 75 rpm
Fast Idle	3350 ± 50 rpm	3350 ± 50 rpm	3350 ± 50 rpm
Valves	Overhead	Overhead	Overhead
Lubrication	Pressurized	Pressurized	Pressurized
Oil Filter	Full Flow Filter	Full Flow Filter	Full Flow Filter
Cooling System	Air Cooled	Air Cooled	Air Cooled
Air Cleaner	Dual Stage Paper Air Filter and Foam Precleaner	Dual Stage Paper Air Filter and Foam Precleaner	Dual Stage Paper Air Filter and Foam Precleaner
Muffler	Horizontal Discharge Below Frame	Horizontal Discharge Below Frame	Horizontal Discharge Below Frame
Engine Oil Capacity (with filter)	1.5 L (3.2 pt.)	1.8 L (3.8 pt.)	1.8 L (3.8 pt.)

GENERAL VEHICLE SPECIFICATIONS (CONTINUED)

Model:	GT242	GT262	GT275
FUEL SYSTEM			
Fuel Tank Location	Rear	Rear	Rear
Fuel Tank Capacity	10.4 L (2.75 U.S. gal)	10.4 L (2.75 U.S. gal)	10.4 L (2.75 U.S. gal)
Fuel (min. octane)	Unleaded Gasoline, 87 Octane	Unleaded Gasoline, 87 Octane	Unleaded Gasoline, 87 Octane
Fuel Pump Location	On left hand side of engine	On left hand side of engine	On left hand side of engine
Type	Diaphragm Vacuum Pulse	Diaphragm Vacuum Pulse	Diaphragm Vacuum Pulse
Fuel Gauge	Translucent Fuel Tank	Translucent Fuel Tank	Translucent Fuel Tank
Fuel Delivery	Float Side Draft Carburetor	Float Side Draft Carburetor	Float Side Draft Carburetor
Fuel Shut-Off	Fuel Shutoff Solenoid	Fuel Shutoff Solenoid	Fuel Shutoff Solenoid
Fuel Filter	Replaceable, In-Line	Replaceable, In-Line	Replaceable, In-Line
ELECTRICAL			
Ignition	Electronic	Electronic	Electronic
Type of Starter	Solenoid Shift	Solenoid Shift	Solenoid Shift
Charging System	Flywheel Alternator	Flywheel Alternator	Flywheel Alternator
Charging Capacity	15 amp Regulated	15 amp Regulated	15 amp Regulated
Battery Type	BCI Group, U1	BCI Group, U1	BCI Group, U1
Battery Voltage	12 volt	12 volt	12 volt
Battery Reserve Capacity at 25 amp.	38 minutes	38 minutes	38 minutes
Battery Cold Cranking Amps at 0° F	295 amps	295 amps	295 amps
Headlights	Incandescent	Incandescent	Incandescent
Indicator Lights	Battery Charge	Engine Oil Pressure, Battery Charge	Engine Oil Pressure, Battery Charge
Ignition Interlock Switches	Neutral Start, Operator Presence	Neutral Start, Operator Presence	Neutral Start, Operator Presence



GENERAL VEHICLE SPECIFICATIONS (CONTINUED)

Model:	GT242	GT262	GT275
POWER TRAIN			
Drive Wheels	Rear	Rear	Rear
Transmission	Transaxle (Gear)	Transaxle (Gear)	Hydrostatic, Piston Type
Traction Drive	Transaxle - Clutch and Gear 6 Speeds Forward 1 Speed Reverse	Transaxle - Clutch and Gear 6 Speeds Forward 1 Speed Reverse	Hydrostatic - Twin Touch Foot Control
Transmission Drive	Belt	Belt	Belt
Transmission Filter	None	None	Replaceable Internal Cartridge
Fan Blade Size	None	None	7 in. Diameter
Lubricant Capacity	3.3 L (3.4 qt)	3.3 L (3.4 qt)	4.3 L (4.7 qt.)
Axle Type/Hub Wheels	Straight with Separate 5-Bolt Hubs	Straight with Separate 5-Bolt Hubs	Straight with Separate 5-Bolt Hubs
Travel Speeds			
Forward - Hydrostatic			0–11.2 km/h (0–7 mph)
Forward - Geared			
1st Gear	1.13 km/h (0.7 mph)	1.13 km/h (0.7 mph)	
2nd Gear	2.25 km/h (1.4 mph)	2.25 km/h (1.4 mph)	
3rd Gear	3.86 km/h (2.4 mph)	3.86 km/h (2.4 mph)	
4th Gear	5.31 kp/h (3.3 mph)	5.31 kp/h (3.3 mph)	
5th Gear	6.76 kp/h (4.2 mph)	6.76 kp/h (4.2 mph)	
6th Gear (Fast Idle)	10.62 kp/h (6.6 mph)	10.62 kp/h (6.6 mph)	
Reverse	4.3 km/h (2.7 mph)	4.3 km/h (2.7 mph)	0–6.4 km/h (0–4 mph)
Clutch	Left Pedal - V-Belt	Left Pedal - V-Belt	None
Clutch	Left Pedal - V-Belt	Left Pedal - V-Belt	None

GENERAL VEHICLE SPECIFICATIONS (CONTINUED)

Model:	GT242	GT262	GT275
STEERING			
Type	Sector and Pinion	Sector and Pinion	Sector and Pinion
BRAKES			
Location	Transmission	Transmission	Transmission
Type	Internal Wet Disk, Right Pedal w/Clutch Interlock	Internal Wet Disk, Right Pedal w/Clutch Interlock	Internal Wet Disk, Single Pedal
Parking Brake	Right Pedal with Clutch Interlock and Lock Lever	Right Pedal with Clutch Interlock and Lock Lever	Brake Pedal Lock Lever
IMPLEMENT LIFT			
Lift System	Manual with Depth Stop	Manual with Depth Stop	Manual with Depth Stop
Lift Assist Type	Fixed Spring	Fixed Spring	Fixed Spring
Lift Lever Location	Left-hand Side of Hood	Left-hand Side of Hood	Left-hand Side of Hood
Cutting Heights mm	25.4–101.6 mm (12.7 mm increments)	25.4–101.6 mm (12.7 mm increments)	25.4–101.6 mm (12.7 mm increments)
in.	1.0–4.0 in. (0.5 in. increments)	1.0–4.0 in. (0.5 in. increments)	1.0–4.0 in. (0.5 in. increments)
ATTACHMENTS			
Cutting Unit Drive	Belt	Belt	Belt



GENERAL VEHICLE SPECIFICATIONS (CONTINUED)

Model:	GT242	GT262	GT275
WEIGHTS AND DIMENSIONS			
 Net Weight (less attachments and fuel)	257 kg (565 lbs)	284 kg (625 lbs)	284 kg (625 lbs)
Mower Deck Weight			
38-Inch Mower Deck	43 kg (95 lbs)	43 kg (95 lbs)	43 kg (95 lbs)
44-Inch Mower Deck	49 kg (108 lbs)	49 kg (108 lbs)	49 kg (108 lbs)
48-Inch Mower Deck	57 kg (125 lbs)	57 kg (125 lbs)	57 kg (125 lbs)
Wheel Base	1.21 m (47.750 in.)	1.21 m (47.750 in.)	1.21 m (47.750 in.)
Tread Width			
Front	0.74 cm (29 in.)	0.74 cm (29 in.)	0.74 cm (29 in.)
Rear	72.5 cm (28.50 in.)	72.5 cm (28.50 in.)	72.5 cm (28.50 in.)
Turning Radius			
Inside Rear Wheel	50.8 cm (20 in.)	50.8 cm (20 in.)	50.8 cm (20 in.)
Outside Front	203 cm (80 in.)	203 cm (80 in.)	203 cm (80 in.)
Overall Length	1.79 m (70.5 in.)	1.79 m (70.5 in.)	1.79 m (70.5 in.)
Overall Height	1.09 m (43 in.)	1.09 m (43 in.)	1.09 m (43 in.)
Overall Width (less attachments)	0.99 m (39 in.)	0.99 m (39 in.)	0.99 m (39 in.)
With 38-Inch Mower Deck	1.33 m (52.600 in.)	1.33 m (52.600 in.)	1.33 m (52.600 in.)
With 44-Inch Mower Deck	1.16 m (45.7 in.)	1.16 m (45.7 in.)	1.16 m (45.7 in.)
With 48-Inch Mower Deck	1.52 m (60 in.)	1.52 m (60 in.)	1.52 m (60 in.)

WHEELS AND TIRES

Front	16 x 6.50-8, 2 or 4 ply, Turf *	16 x 6.50-8, 2 or 4 ply, Turf	16 x 6.50-8, 2 or 4 ply, Turf
Rear	23 x 10.50-12.00, Turf or Bar	23 x 10.50-12.00, Turf or Bar	23 x 10.50-12.00, Turf or Bar

* Engineering change since last edition of this manual.

TORQUE VALUES, NON-STANDARD FASTENERS

NOTE: Torques listed in this GROUP apply ONLY to "special" and/or NON-STANDARD fasteners. Unless otherwise specified, STANDARD fasteners should be torqued per "TORQUE VALUES, STANDARD METRIC FASTENER" on page 10 or "TORQUE VALUES, STANDARD INCH FASTENER" on page 12.



ENGINE

Cylinder Head and Valves

- Rocker Arm Cap Screw Torque 10 N•m (89 lb-in.)
- Valve Adjustment Screw Jam Nut Torque 20 N•m (180 lb-in.)
- Valve Cover Cap Screw Torque 6 N•m (53 lb-in.)
- Cap Screw Torque in Sequence (Lubricated)
at 7 N•m (62 lb-in.) Increments
 - Initial Torque 32 N•m (288 lb-in.)
 - Final Torque. 52 N•m (456 lb-in.)
- Spark Plug Torque 20 N•m (177 lb-in.)

Crankcase Cover

- Mounting Cap Screw Torque 26 N•m (230 lb-in.)

Piston Assembly

- Connecting Rod Cap Screw Torque 20 N•m (177 lb-in.)

Reciprocating Balancer

- Support Shaft Nut Torque 7 N•m (65 lb-in.)

Governor

- Governor Lever Nut Torque 7.8 N•m (69 lb-in.)
- Engine Mounting Cap Screw Torque 16.7—22.6 N•m (148.0—200.0 lb-in.)

Blower Housing Cap Screw Torque 10 N•m (89 lb-in.)

Flywheel Screen To Cooling Fan Cap Screw Torque 6 N•m (53 lb-in.)

Cooling Fan To Flywheel Cap Screw Torque 10 N•m (89 lb-in.)

Cooling Fan Bracket To Flywheel Cap Screw Torque. 12 N•m (102 lb-in.)

Flywheel Mounting Nut Torque

- FC420V 137 N•m (101 lb-ft)
- FC540V 172 N•m (127 lb-ft)

Oil Drain Plug Torque 23 N•m (200 lb-in.)

Stator

- Cap Screw Torque 6 N•m (53 lb-in.)

Magneto Ignition Coil

All Engines Prior To and Including:

FC420V-DS10 (—FC420VB50633)

FC540V-DS15 (—FC540VA00385)

- Cap Screw Torque 6 N•m (53 lb-in.)

Magneto Ignition Coil With Ignitor Module

All Engines After and Including:

FC420V-DS10 (FC420VB50633—)

FC540V-DS15 (FC540VA00385—)

- Cap Screw Torque 6 N•m (53 lb-in.)

Starter

- Starter-To-Engine Mounting Cap Screw Torque 16 N•m (142 lb-in.)

- Starter End Cover Cap Screw Torque 9 N•m (80 lb-in.)

POWER TRAIN, GEAR

Differential Assembly

Housing Bolts 51 N•m (38 lb-ft)

Replaced Transaxle Cases

Force necessary to torque the six (6) bolts in the area of the reduction shaft and a seventh (7th) at the opposite end of the housing.

New Case 29 N•m (22 lb-ft)

Used Case 24 N•m (216 lb-ft)

Brake Assembly

Transaxle Cap Screws

New Case 29 N•m (22 lb-ft)

Used Case 24 N•m (216 lb-ft)

Oil Drain Plugs

Torque Specifications 39 N•m (29 lb-ft)

Retainer Cap Screws

New Case 29 N•m (22 lb-ft)

Used Case 24 N•m (216 lb-ft)

POWER TRAIN, HYDROSTATIC

Transmission

New Case 29 N•m (22 lb-ft)

Rear Transmission-to-Frame Mounting Nut Torque 54 N•m (40 lb-ft)

Front Transmission-to-Frame Mounting Nut Torque 27 N•m (20 lb-ft)

Center Case Cap Screw Torque 54 N•m (40 lb-ft)

Relief Valve Plug Torque 22 N•m (195 lb-in.)

Pump Body Cap Screw Torque 23 N•m (204 lb-in.)

Drain Plug Cap Screw Torque 15 N•m (133 lb-in.)

Housing Cap Screw Torque 23 N•m (204 lb-in.)

OTHER

Electrical

Electric PTO Cap Screw Torque

GT242 75 N•m (55 lb-ft)

GT262 75 N•m (55 lb-ft)

GT275 56 N•m (45 lb-ft)

Steering

Drag Link Nut Torque 30 N•m (22 lb-ft)

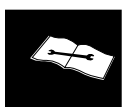

OTHER (Continued)

Attachments

38-Inch Mower Deck

Spindle

Mounting Nut Torque	26 N•m (230 lb-in.)
Sheave Nut Torque	140 N•m (103 lb-ft)

Blade

Blade Cap Screw Torque	68 N•m (55 lb-ft)
----------------------------------	-------------------

44-Inch Rear Discharge Mower Deck

Spindle

Mounting Nut Torque	26 N•m (230 lb-in.)
Sheave Nut Torque	163 N•m (120 lb-ft)

Blade

Blade Cap Screw Torque	68 N•m (50 lb-ft)
----------------------------------	-------------------

48-Inch Mower Deck

Gauge Wheels

Roller Shaft Nut Torque	30 N•m (22 lb-ft)
-----------------------------------	-------------------

Idlers and Sheaves

Jack Sheave Nut Torque	136 N•m (100 lb-ft)
Tensioning Idler Sheave Nut Torque	27 N•m (20 lb-ft)

Spindle

Mounting Nut Torque	26 N•m (230 lb-in.)
Sheave Nut Torque	163 N•m (120 lb-ft)

Blade

Blade Cap Screw Torque	68 N•m (50 lb-ft)
----------------------------------	-------------------

Miscellaneous

Pivot Anchor Cap Screw Torque	25 N•m (228 lb-in.)
Tie Rod Lock Nut Torque	23 N•m (200 lb-in.)
Drag Link Lock Nut Torque	37 N•m (27 lb-ft)
Rear Wheel Cap Screw Torque	88 N•m (65 lb-ft)



METRIC FASTENER TORQUE VALUES

Property Class and Head Markings	4.8		8.8		9.8		10.9		12.9	
Property Class and Nut Markings	5		10		10		10		12	

TS1163

SIZE	Class 4.8				Class 8.8 or 9.8				Class 10.9				Class 12.9			
	Lubricated ^a		Dry ^a		Lubricated ^a		Dry ^a		Lubricated ^a		Dry ^a		Lubricated ^a		Dry ^a	
	N•m	lb-ft	N•m	lb-ft	N•m	lb-ft	N•m	lb-ft	N•m	lb-ft	N•m	lb-ft	N•m	lb-ft	N•m	lb-ft
M6	4.8	3.5	6	4.5	9	6.5	11	8.5	13	9.5	17	12	15	11.5	19	14.5
M8	12	8.5	15	11	22	16	28	20	32	24	40	30	37	28	47	35
M10	23	17	29	21	43	32	55	40	63	47	80	60	75	55	95	70
M12	40	29	50	37	75	55	95	70	110	80	140	105	130	95	165	120
M14	63	47	80	60	120	88	150	110	175	130	225	165	205	150	260	190
M16	100	73	125	92	190	140	240	175	275	200	350	225	320	240	400	300
M18	135	100	175	125	260	195	330	250	375	275	475	350	440	325	560	410
M20	190	140	240	180	375	275	475	350	530	400	675	500	625	460	800	580
M22	260	190	330	250	510	375	650	475	725	540	925	675	850	625	1075	800
M24	330	250	425	310	650	475	825	600	925	675	1150	850	1075	800	1350	1000
M27	490	360	625	450	950	700	1200	875	1350	1000	1700	1250	1600	1150	2000	1500
M30	675	490	850	625	1300	950	1650	1200	1850	1350	2300	1700	2150	1600	2700	2000
M33	900	675	1150	850	1750	1300	2200	1650	2500	1850	3150	2350	2900	2150	3700	2750
M36	1150	850	1450	1075	2250	1650	2850	2100	3200	2350	4050	3000	3750	2750	4750	3500

DO NOT use these hand torque values if a different torque value or tightening procedure is given for a specific application. Torque values listed are for general use only and include a ±10% variance factor. Check tightness of fasteners periodically. DO NOT use air powered wrenches.

Shear bolts are designed to fail under predetermined loads. Always replace shear bolts with identical grade.

Fasteners should be replaced with the same class. Make sure fastener threads are clean and that you properly start thread engagement. This will prevent them from failing when tightening.

When bolt and nut combination fasteners are used, torque values should be applied to the **NUT** instead of the bolt head.

Tighten toothed or serrated-type lock nuts to the full torque value.

^a "Lubricated" means coated with a lubricant such as engine oil, or fasteners with phosphate and oil coatings. "Dry" means plain or zinc plated (yellow dichromate - Specification JDS117) without any lubrication.

Reference: JDS—G200.











METRIC FASTENER TORQUE VALUE – GRADE 7

Size	Steel or Gray Iron Torque		Aluminum Torque	
	N•m	lb-ft	N•m	lb-ft
M6	11	8	8	6
M8	24	18	19	14
M10	52	38	41	30
M12	88	65	70	52
M14	138	102	111	82
M16	224	165	179	132



INCH FASTENER TORQUE VALUES



SAE Grade and Head Markings	1 or 2 ^b No Marks 	5  5.1  5.2 	8  8.2 
	2 No Marks 	5  	8  

TS1162

SIZE	Grade 1				Grade 2 ^b				Grade 5, 5.1 or 5.2				Grade 8 or 8.2			
	Lubricated ^a		Dry ^a		Lubricated ^a		Dry ^a		Lubricated ^a		Dry ^a		Lubricated ^a		Dry ^a	
	N•m	lb-ft	N•m	lb-ft	N•m	lb-ft	N•m	lb-ft	N•m	lb-ft	N•m	lb-ft	N•m	lb-ft	N•m	lb-ft
1/4	3.7	2.8	4.7	3.5	6	4.5	7.5	5.5	9.5	7	12	9	13.5	10	17	12.5
5/16	7.7	5.5	10	7	12	9	15	11	20	15	25	18	28	21	35	26
3/8	14	10	17	13	22	16	27	20	35	26	44	33	50	36	63	46
7/16	22	16	28	20	35	26	44	32	55	41	70	52	80	58	100	75
1/2	33	25	42	31	53	39	67	50	85	63	110	80	120	90	150	115
9/16	48	36	60	45	75	56	95	70	125	90	155	115	175	130	225	160
5/8	67	50	85	62	105	78	135	100	170	125	215	160	215	160	300	225
3/4	120	87	150	110	190	140	240	175	300	225	375	280	425	310	550	400
7/8	190	140	240	175	190	140	240	175	490	360	625	450	700	500	875	650
1	290	210	360	270	290	210	360	270	725	540	925	675	1050	750	1300	975
1-1/8	470	300	510	375	470	300	510	375	900	675	1150	850	1450	1075	1850	1350
1-1/4	570	425	725	530	570	425	725	530	1300	950	1650	1200	2050	1500	2600	1950
1-3/8	750	550	950	700	750	550	950	700	1700	1250	2150	1550	2700	2000	3400	2550
1-1/2	1000	725	1250	925	990	725	1250	930	2250	1650	2850	2100	3600	2650	4550	3350

DO NOT use these hand torque values if a different torque value or tightening procedure is given for a specific application. Torque values listed are for general use only and include a ±10% variance factor. Check tightness of fasteners periodically. DO NOT use air powered wrenches.

Shear bolts are designed to fail under predetermined loads. Always replace shear bolts with identical grade.

Fasteners should be replaced with the same grade. Make sure fastener threads are clean and that you properly start thread engagement. This will prevent them from failing when tightening.

When bolt and nut combination fasteners are used, torque values should be applied to the **NUT** instead of the bolt head.

Tighten toothed or serrated-type lock nuts to the full torque value.

^a "Lubricated" means coated with a lubricant such as engine oil, or fasteners with phosphate and oil coatings. "Dry" means plain or zinc plated (yellow dichromate - Specification JDS117) without any lubrication.

^b "Grade 2" applies for hex cap screws (not hex bolts) up to 152 mm (6-in.) long. "Grade 1" applies for hex cap screws over 152 mm (6-in.) long, and for all other types of bolts and screws of any length.

Reference: JDS—G200.

GASOLINE SPECIFICATIONS

4-CYCLE ENGINES – NORTH AMERICA

CAUTION

Gasoline is **HIGHLY FLAMMABLE**, handle it with care.

DO NOT refuel machine while:

- indoors, always fill gas tank outdoors;
- machine is near an open flame or sparks;
- engine is running, **STOP** engine;
- engine is hot, allow it to cool sufficiently first;
- smoking.

Help prevent fires:

- fill gas tank to bottom of filler neck only;
- be sure fill cap is tight after fueling;
- clean up any gas spills **IMMEDIATELY**;
- keep machine clean and in good repair—free of excess grease, oil, debris, and faulty or damaged parts;
- any storage of machines with gas left in tank should be in an area that is well ventilated to prevent possible igniting of fumes by an open flame or spark, this includes any appliance with a pilot light.

To prevent fire or explosion caused by STATIC ELECTRIC DISCHARGE during fueling:

- **ONLY** use a clean, approved **POLYETHYLENE PLASTIC** fuel container and funnel **WITHOUT** any metal screen or filter.

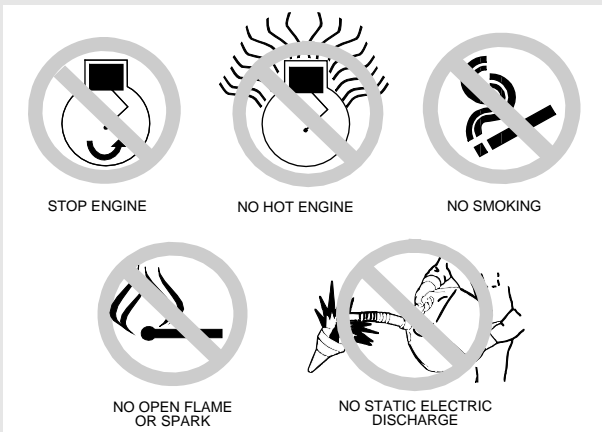

To avoid engine damage:

- DO NOT mix oil with gasoline;
- **ONLY** use clean, fresh unleaded gasoline with an octane rating (anti-knock index) of 87 or higher;
- fill gas tank at the end of each day's operation to help prevent condensation from forming inside a partially filled tank;
- keep up with specified service intervals.

Use of alternative oxygenated, gasohol blended, unleaded gasoline is acceptable as long as:

- the ethyl or grain alcohol blends DO NOT exceed 10% by volume or
- methyl tertiary butyl ether (MTBE) blends DO NOT exceed 15% by volume.

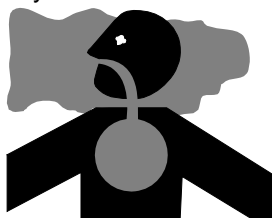

IMPORTANT: DO NOT use **METHANOL** gasolines because **METHANOL** is harmful to the environment and to your health.

WARNING

California Proposition 65 Warning: Gasoline engine exhaust from this product contains chemicals known to the State of California to cause cancer, birth defects, or other reproductive harm.

GASOLINE STORAGE

IMPORTANT: Keep all dirt, scale, water or other foreign material out of gasoline.

Keep gasoline stored in a safe, protected area. Storage of gasoline in a clean, properly marked ("**UNLEADED GASOLINE**") **POLYETHYLENE PLASTIC** container **WITHOUT** any metal screen or filter is recommended. **DO NOT** use de-icers to attempt to remove water from gasoline or depend on fuel filters to remove water from gasoline. Use a water separator installed in the storage tank outlet. **BE SURE** to properly discard unstable or contaminated gasoline. When storing unit or gasoline, it is recommended that you add **John Deere Gasoline Conditioner and Stabilizer (TY15977)** or an equivalent to the gasoline. **BE SURE** to follow directions on container and to properly discard empty container.

ENGINE OIL SPECIFICATIONS

4-CYCLE GASOLINE ENGINE OIL – NORTH AMERICA

Use the appropriate oil viscosity based on the expected air temperature range during the period between recommended oil changes. Operating outside of these recommended oil air temperature ranges may cause premature engine failure.

The following John Deere oils are **PREFERRED**:

- **PLUS-4®—SAE 10W-40;**
- **TORQ-GARD SUPREME®—SAE 5W-30.**

The following John Deere oils are **also recommended**, based on their specified temperature range:

- **TURF-GARD®—SAE 10W-30;**
- **PLUS-4®—SAE 10W-30;**
- **TORQ-GARD SUPREME®—SAE 30.**

Other oils may be used if above John Deere oils are not available, provided they meet one of the following specifications:

- SAE 10W-40—API Service Classification SG or higher;
- SAE 5W-30—API Service Classification SG or higher;
- SAE 10W-30—API Service Classification SG or higher;
- SAE 30—API Service Classification SC or higher.

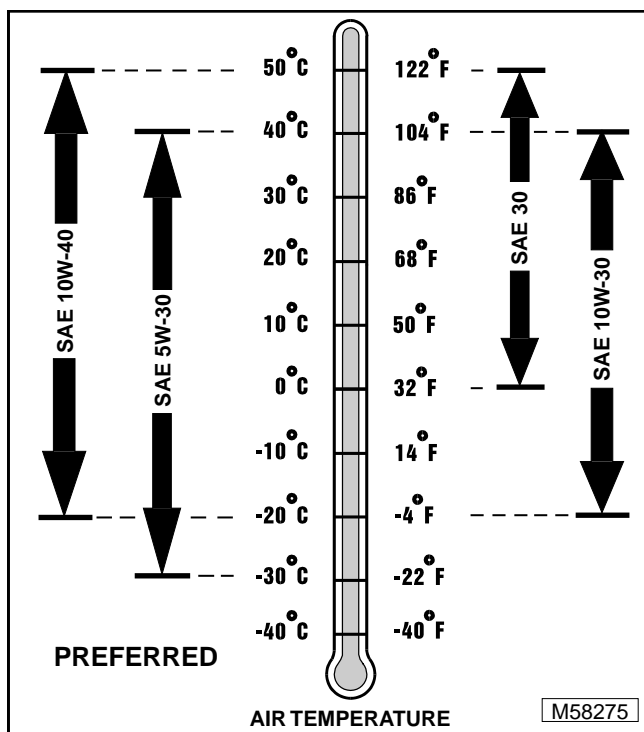

BREAK-IN 4-CYCLE GASOLINE ENGINE OIL – NORTH AMERICA

IMPORTANT: After the break-in period, use the John Deere oil that is recommended or its equivalent for this engine.

IMPORTANT: ONLY use a quality break-in oil in rebuilt or remanufactured engines for the first 5 hours (maximum) of operation. DO NOT use oils with heavier viscosity weights than SAE 5W-30 or oils meeting specifications API SG or SH, these oils will not allow rebuilt or remanufactured engines to break-in properly.

The following John Deere oil is **PREFERRED**:

- **BREAK-IN ENGINE OIL.**

John Deere BREAK-IN ENGINE OIL is formulated with special additives for aluminum and cast iron type engines to allow the power cylinder components (pistons, rings, and liners as well) to “wear-in” while protecting other engine components, valve train and gears, from abnormal wear. Engine rebuild instructions should be followed closely to determine if special requirements are necessary.

John Deere BREAK-IN ENGINE OIL is also recommended for non-John Deere engines, both aluminum and cast iron types.

The following John Deere oil is **also recommended** as a break-in engine oil:

- **TORQ-GARD SUPREME®—SAE 5W-30.**

If the above recommended John Deere oils are not available, use a break-in engine oil meeting the following specification during the first 5 hours (maximum) of operation:

- SAE 5W-30—API Service Classification SE or higher.

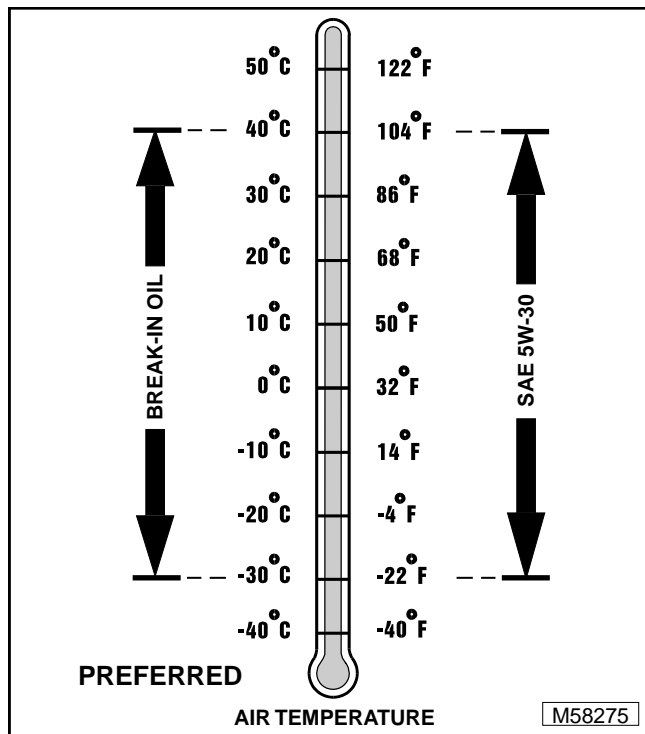

HYDROSTATIC TRANSMISSION AND HYDRAULIC OIL



Use the appropriate oil viscosity based on these air temperature ranges. Operating outside of these recommended oil air temperature ranges may cause premature hydrostatic transmission or hydraulic system failures.

IMPORTANT: Mixing of **LOW VISCOSITY HY-GARD®** and **HY-GARD®** oils is permitted. **DO NOT** mix any other oils in this transmission. **DO NOT** use engine oil or “Type F” (Red) Automatic Transmission Fluid in this transmission. **DO NOT** use **BIO-HY-GARD®** in this transmission.

The following John Deere transmission and hydraulic oil is **PREFERRED**:

- **LOW VISCOSITY HY-GARD®—JDM J20D.**

The following John Deere oil is **also recommended** if above preferred oil is not available:

- **HY-GARD®—JDM J20C.**

Other oils may be used if above recommended John Deere oils are not available, provided they meet one of the following specifications:

- John Deere Standard JDM J20D;
- John Deere Standard JDM J20C.

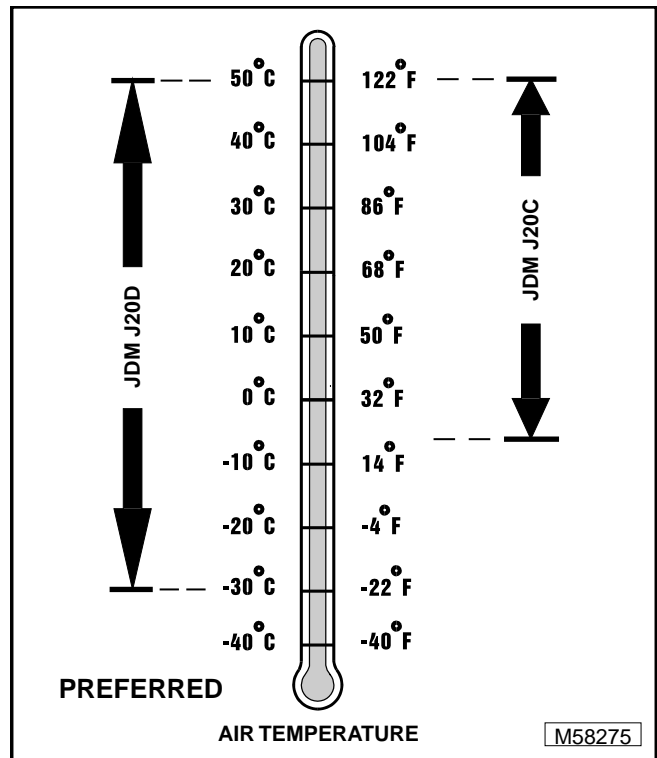

ANTI-CORROSION GREASE SPECIFICATIONS

This anti-corrosion grease is formulated to provide the best protection against absorbing moisture, which is one of the major causes of corrosion. This grease is also superior in its resistance to separation and migration.

The following anti-corrosion grease is **PREFERRED**:

- **DuBois MPG-2® Multi-Purpose Polymer Grease—M79292.**

Other greases may be used if they meet or exceed the following specifications:

- John Deere Standard JDM J13A2, NLGI Grade 1.

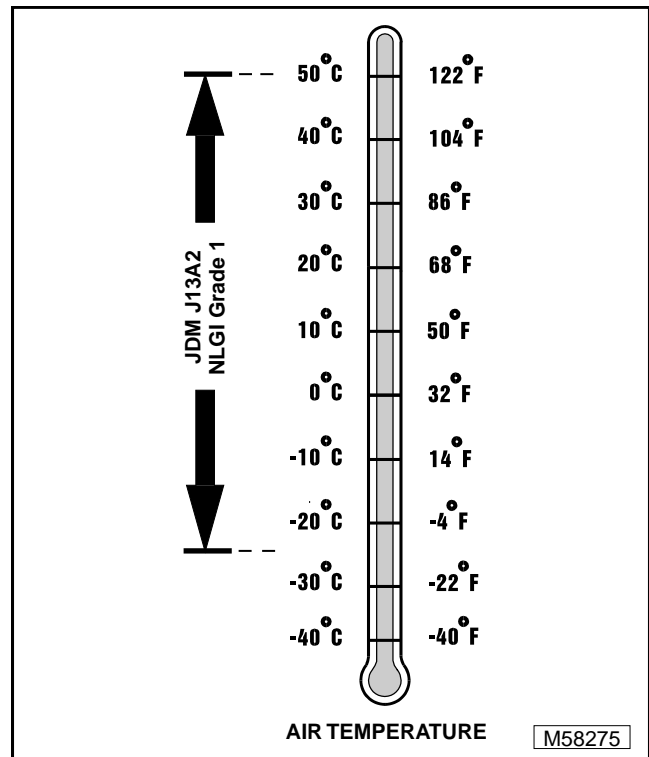

GENERAL APPLICATION GREASE SPECIFICATIONS



GREASE – NORTH AMERICA

Use the following grease based on the air temperature range. Operating outside of the recommended grease air temperature range may cause premature failures.

IMPORTANT: ONLY use a quality grease in this application. DO NOT mix any other greases in this application. DO NOT use any BIO-GREASE in this application.

The following John Deere grease is **PREFERRED**:

- **NON-CLAY HIGH-TEMPERATURE EP GREASE®—JDM J13E4, NLGI Grade 2.**

Other greases may be used if above preferred John Deere grease is not available, provided they meet the following specification:

- John Deere Standard JDM J13E4, NLGI Grade 2.

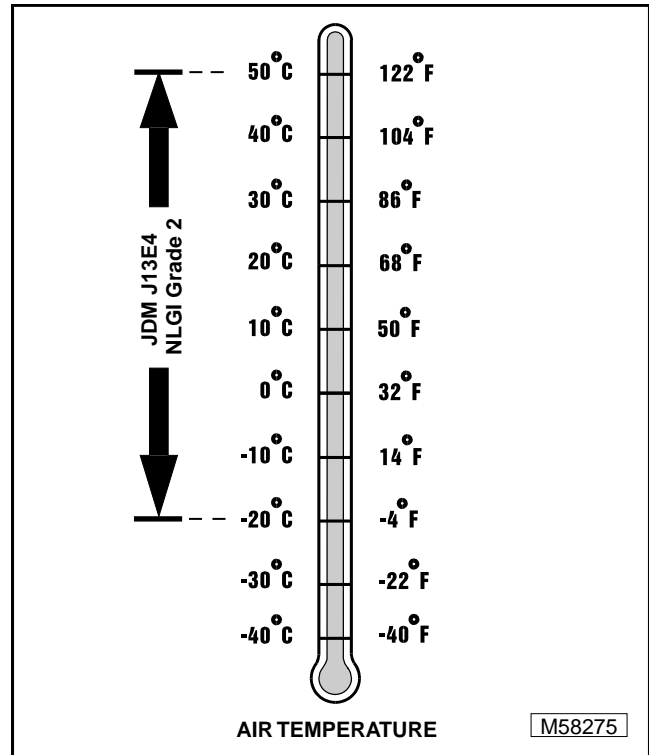

ALTERNATIVE LUBRICANTS

Conditions in certain geographical areas outside the United States and Canada may require different lubricant recommendations than the ones printed in this technical manual or the operator's manual. Consult with your John Deere Dealer, or Sales Branch, to obtain the alternative lubricant recommendations.

IMPORTANT: Use of alternative lubricants could cause reduced life of the component.

If alternative lubricants are to be used, it is recommended that the factory fill be thoroughly removed before switching to any alternative lubricant.

SYNTHETIC LUBRICANTS

Synthetic lubricants may be used in John Deere equipment if they meet the applicable performance requirements (industry classification and/or military specification) as shown in this manual.

The recommended air temperature limits and service or lubricant change intervals should be maintained as shown in the operator's manual.

Avoid mixing different brands, grades, or types of oil. Oil manufacturers blend additives in their oils to meet certain specifications and performance requirements. Mixing different oils can interfere with the proper functioning of these additives and degrade lubricant performance.

LUBRICANT STORAGE

All machines operate at top efficiency only when clean lubricants are used. Use clean storage containers to handle all lubricants. Store them in an area protected from dust, moisture, and other contamination. Store drums on their sides. Make sure all containers are properly marked as to their contents. Dispose of all old, used containers and their contents properly.

MIXING OF LUBRICANTS

In general, avoid mixing different brands or types of lubricants. Manufacturers blend additives in their lubricants to meet certain specifications and performance requirements. Mixing different lubricants can interfere with the proper functioning of these additives and lubricant properties which will downgrade their intended specified performance.



OIL FILTERS

IMPORTANT: Filtration of oils is critical to proper lubrication performance. Always change filters regularly.

The following John Deere oil filters are PREFERRED:

- AUTOMOTIVE AND LIGHT TRUCK ENGINE OIL FILTERS.

Most John Deere filters contain pressure relief and anti-drainback valves for better engine protection.

Other oil filters may be used if above recommended John Deere oil filters are not available, provided they meet the following specification:

- ASTB Tested In Accordance With SAE J806.

SERIAL NUMBER LOCATION

When ordering parts or submitting a warranty claim, it is **IMPORTANT** that the machine product identification number and component serial numbers are included. The location of the machine identification number and component serial numbers are shown.



MACHINE IDENTIFICATION NUMBER

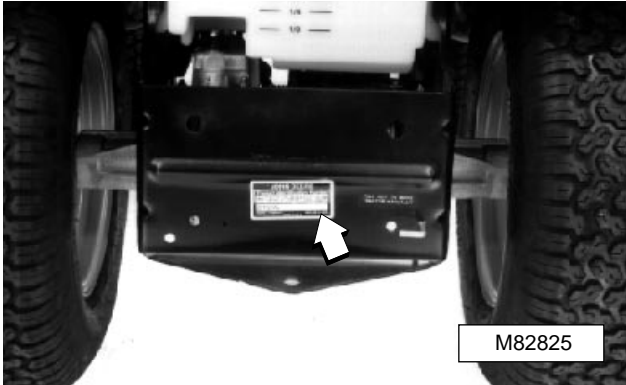

ENGINE SERIAL NUMBER

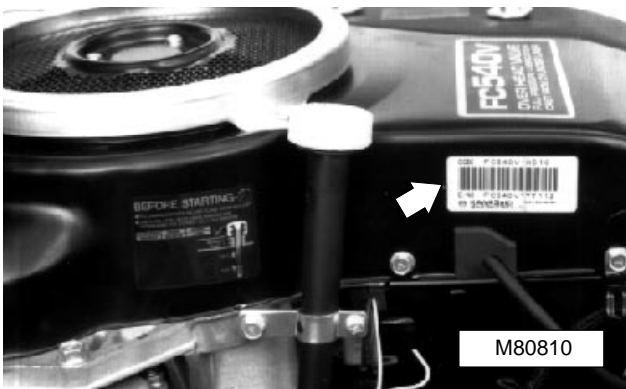

CARBURETOR SERIAL NUMBER

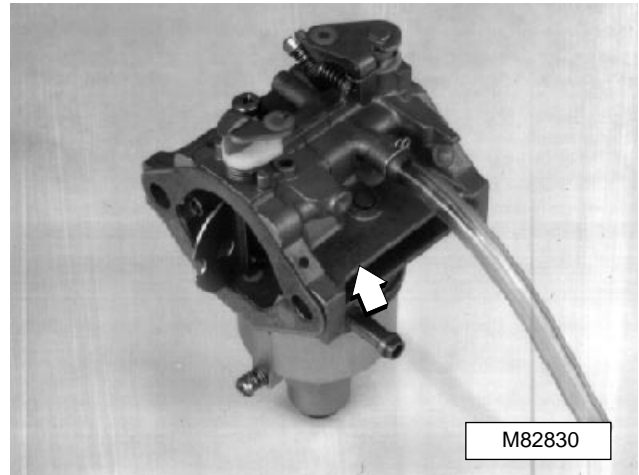

GEAR TRANSAXLE SERIAL NUMBER LOCATION

NOTE: Fuel tank removed for clarity. Serial number can be seen by looking over right-hand rear corner of frame.

The transaxle serial number (A) is stamped on top of case.

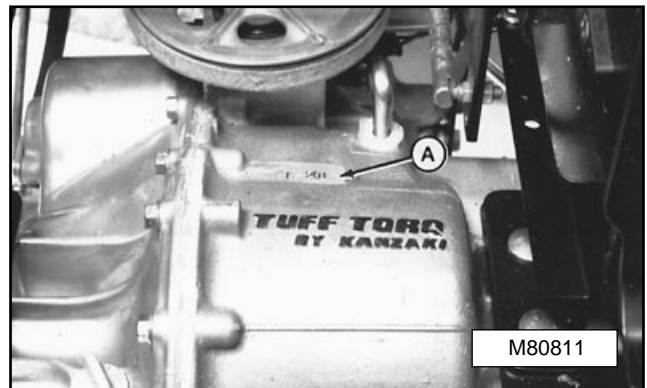

HYDROSTATIC TRANSMISSION SERIAL NUMBER

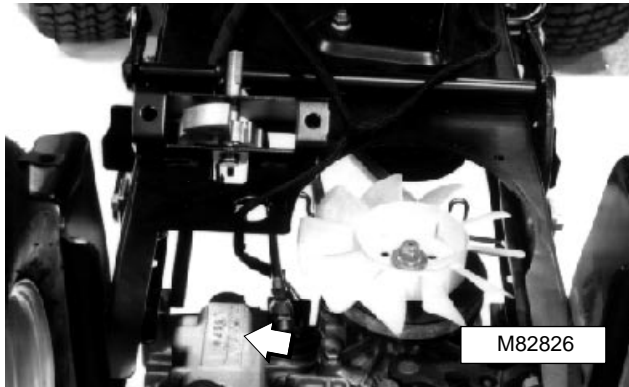

MOWER DECK SERIAL NUMBER LOCATION



38 and 48-Inch Mower Decks



44-Inch Rear Discharge Mower Deck



This page intentionally left blank.

CONTENTS

Page

SPECIFICATIONS

TEST AND ADJUSTMENT SPECIFICATIONS	3-4
REPAIR SPECIFICATIONS	3-4
ENGINE DESIGNATION	3-4
SPECIAL OR ESSENTIAL TOOLS	3-9
OTHER MATERIALS	3-10
SERVICE PARTS KITS	3-10

COMPONENT LOCATION

EXTERNAL ENGINE COMPONENTS	3-11
INTERNAL ENGINE COMPONENTS	3-12
OIL PUMP BREATHER AND COMPRESSION RELEASE COMPONENTS	3-13
FUEL AND AIR SYSTEM COMPONENTS	3-14

THEORY OF OPERATION

LUBRICATION SYSTEM OPERATION	3-15
COOLING SYSTEM OPERATION	3-17

TROUBLESHOOTING

ENGINE AND FUEL SYSTEM TROUBLESHOOTING CHART	3-19
ENGINE TROUBLESHOOTING GUIDE	3-21
STARTER MOTOR TROUBLESHOOTING GUIDE	3-25

TESTS AND ADJUSTMENTS

THROTTLE CABLE TEST AND ADJUSTMENT	3-26
CHOKE PLATE TEST AND ADJUSTMENT	3-26
GOVERNOR ADJUSTMENT	3-27
FAST IDLE SPEED ADJUSTMENT	3-28
SLOW IDLE SPEED ADJUSTMENT	
NON CARB/EPA ENGINES	3-29
SLOW IDLE SPEED ADJUSTMENT	
CARB/EPA ENGINES	3-29
CYLINDER COMPRESSION PRESSURE TEST	3-31
VALVE CLEARANCE TEST AND ADJUSTMENT	3-32
AUTOMATIC COMPRESSION RELEASE (ACR) TEST	3-32
CRANKCASE VACUUM TEST	3-33
ENGINE OIL PRESSURE TEST	3-34
FUEL PUMP TESTS	3-34
SPARK TEST	3-35
SPARK PLUG GAP ADJUSTMENT	3-36
MAGNETO IGNITION COIL RESISTANCE TEST	3-36
IGNITOR MODULE TEST	3-37
MAGNETO IGNITION COIL/IGNITOR MODULE RESISTANCE TEST	3-37
CRANKSHAFT END PLAY TEST AND ADJUSTMENT	3-39
STARTER NO LOAD AMPERAGE DRAW AND RPM BENCH TEST	3-40



	Page
CONTENTS CONTINUED	
REPAIR	
FUEL TANK	3-41
Removal/Installation	3-41
THROTTLE CONTROL LEVER AND CABLE	3-41
Removal/Installation	3-41
ENGINE	3-42
Removal/Installation	3-42
MUFFLER	3-43
Removal/Installation	3-43
AIR CLEANER	3-43
Service	3-43
CARBURETOR	3-44
Removal/Installation	3-44
Disassembly/Assembly	3-44
Clean/Inspect/Rebuild	3-47
FUEL PUMP	3-47
Replacement	3-47
BREATHER	3-47
Inspection/Replacement	3-47
BLOWER HOUSING	3-48
Removal/Installation	3-48
Flywheel Screen Adjustment	3-49
FLYWHEEL	3-50
Removal/Installation	3-50
ROCKER ARM ASSEMBLY	3-50
Removal/Installation	3-50
Inspection	3-51
CYLINDER HEAD AND VALVES	3-51
Removal/Installation	3-51
Disassembly/Assembly	3-52
Inspection	3-53
Valve Guide Replacement	3-54
ANALYZE VALVES	3-55
RECONDITION VALVE SEATS	3-56
LAP VALVES	3-56
CRANKCASE COVER	3-56
Removal/Installation	3-56
PISTON AND CONNECTING ROD	3-57
Removal	3-57
Installation	3-57
Disassembly	3-57
Assembly	3-58
Inspection	3-58
ANALYZE PISTON RING WEAR	3-60

CONTENTS CONTINUED

ANALYZE PISTON WEAR	3-62
CAMSHAFT AND TAPPETS	3-63
Removal	3-63
Installation	3-63
Inspection	3-64
RECIPROCATING BALANCER	3-65
Removal/Installation	3-65
Disassembly/Assembly	3-65
Inspection	3-66
Bearing Replacement	3-66
CRANKSHAFT AND MAIN BEARINGS	3-67
Removal/Installation	3-67
Inspection	3-67
CRANKSHAFT OIL SEALS	3-68
Replacement	3-68
ANALYZE CRANKSHAFT AND CONNECTING ROD WEAR	3-69
CYLINDER BLOCK	3-69
Inspection	3-69
Deglaze Cylinder Bore	3-69
Rebore Cylinder Block	3-70
OIL PUMP	3-70
Disassembly/Assembly	3-70
Inspection	3-71
OIL FILTER MANIFOLD	3-73
Removal/Installation	3-73
GOVERNOR	3-73
Inspection/Replacement	3-73
GOVERNOR SHAFT	3-73
Inspection/Replacement	3-73
STATOR	3-74
Removal/Installation	3-74
IGNITOR MODULE	3-74
Replacement	3-74
IGNITION COIL	3-74
Removal/Installation	3-74
Air Gap Adjustment	3-75
STARTER	3-75
Analyze Condition	3-75
Removal/Installation	3-75
Disassembly/Assembly	3-75



SPECIFICATIONS
ENGINE DESIGNATION

NOTE: GT242 tractor uses engine model number FC420V, GT262 and GT275 tractors use engine model number FC540V.

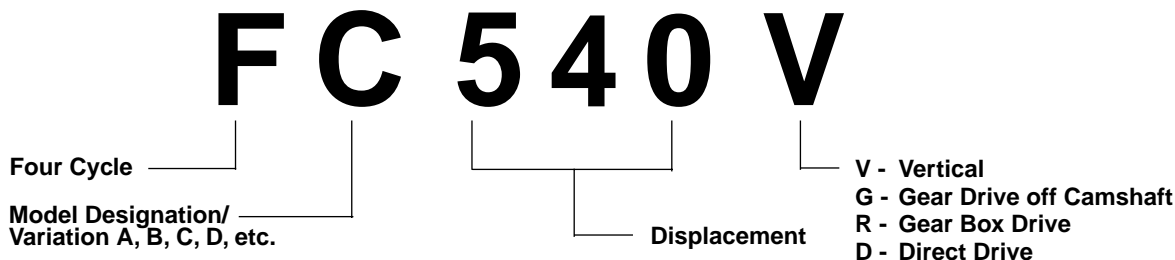

TEST AND ADJUSTMENT SPECIFICATIONS

SLOW Idle

Carburetor SLOW Idle Stop Screw Setting 1450 ±75 rpm

Throttle Control Arm

SLOW Idle Stop Screw Setting 1550 ±75 rpm

FAST Idle 3350 ±100 rpm

Cylinder Compression Pressure (Minimum) 483 kPa (71 psi)

Valve Clearance (Cold) 0.15 mm (0.006 in.)

Jam Nut Torque 20 N•m (180 lb-in.)

Valve Cover Cap Screw Torque 6 N•m (53 lb-in.)

Exhaust Valve ACR Movement (Minimum) 0.25 mm (0.010 in.)

Crankcase Vacuum (Minimum) 25 cm (1.0 in.) of water movement

Engine Oil Pressure (Minimum)

FAST Idle (3350 ±100 rpm) 240 kPa (35 psi)

SLOW Idle (1550 ±75 rpm) 20.68 kPa (3 psi)

Fuel Pump Pressure (Minimum) 6.12 kPa (0.90 psi)

Fuel Pump Flow (Minimum)

FC420V 55 mL/15 seconds (1.8 oz/15 seconds)

FC540V 65 mL/15 seconds (2.2 oz/15 seconds)

Crankshaft End Play 0.09—0.22 mm (0.004—0.009 in.)

Spark Plug Gap 0.76 mm (0.030 in.)

Spark Plug Torque 20 N•m (177 lb-in.)

REPAIR SPECIFICATIONS

Rock Arm Assembly

Shaft O.D. (Minimum) 12.94 mm (0.509 in.)

Bearing I.D. (Maximum) 13.07 mm (0.515 in.)

Push Rod Bend (Maximum) 0.30 mm (0.012 in.)

REPAIR SPECIFICATIONS (Continued)

Cylinder Head and Valves

Rocker Arm Cap Screw Torque	10 N•m (89 lb-in.)
Valve Adjustment Screw Jam Nut Torque	20 N•m (180 lb-in.)
Valve Cover Cap Screw Torque	6 N•m (53 lb-in.)

Cap Screw Torque in Sequence (Lubricated)
at 7 N•m (62 lb-in.) Increments

Initial Torque	32 N•m (288 lb-in.)
Final Torque	52 N•m (456 lb-in.)
Spark Plug Torque	20 N•m (177 lb-in.)
Cylinder Head Distortion (Maximum)	0.05 mm (0.002 in.)

Valve Guide I.D. (Maximum)

FC420V	7.015 mm (0.2762 in.)
FC540V	7.07 mm (0.2780 in.)

Valve Seating Surface	1.10—1.46 mm (0.043—0.057 in.)
---------------------------------	--------------------------------

Valve Spring Free Length (Minimum)

Early Model	37.50 mm (1.476 in.)
Late Model	35.50 mm (1.398 in.)

Valve Margin (Minimum)	0.60 mm (0.024 in.)
----------------------------------	---------------------

Valve Stem Bend (Maximum)	0.03 mm (0.001 in.)
-------------------------------------	---------------------

Valve Guide Installation Depth

FC420V	12 ±0.1 mm (0.472 ±0.004 in.)
FC540V	9.5 ±0.1 mm (0.370 ±0.004 in.)

Finished Valve Guide I.D. (Reamed)	7.00—7.02 mm (0.275—0.276 in.)
--	--------------------------------

Valve Seat and Face Angle	45°
-------------------------------------	-----

Valve Narrow Angle	30°
------------------------------	-----

Breather Air Gap	1—2 mm (0.040—0.080 in.)
----------------------------	--------------------------

Crankcase Cover

Oil Capacity (w/Filter) FC420V	1.6 L (3.4 U.S. pt)
--	---------------------

Oil Capacity (w/Filter) FC540V	1.9 L (4.0 U.S. pt)
--	---------------------

Mounting Cap Screw Torque	26 N•m (230 lb-in.)
-------------------------------------	---------------------

Piston Assembly

Piston Ring Groove Side Clearance (Maximum)

Top Ring	0.17 mm (0.007 in.)
Second Ring	0.15 mm (0.006 in.)
Oil Ring	0.20 mm (0.008 in.)

Pin O.D. (Minimum)

Early Model	21.98 mm (0.865 in.)
Late Model	18.975 mm (0.747 in.)

Pin Bore I.D. (Maximum)

Early Model	22.04 mm (0.868 in.)
Late Model	19.042 mm (0.7497 in.)

Piston O.D.

Standard Piston	88.830—88.864 mm (3.4885—3.4984 in.)
Oversize Piston 0.50 mm (0.020 in.)	89.330—89.364 mm (3.517—3.518 in.)

Cylinder Bore I.D.

Standard Size Bore

Standard	88.980—89.000 mm (3.5031—3.5039 in.)
Wear Limit (Maximum)	89.076 mm (3.5069 in.)

Oversize Bore—0.50 mm (0.020 in.)

Standard	89.480—89.500 mm (3.5228—3.5236 in.)
Wear Limit (Maximum)	89.576 mm (3.5266 in.)



REPAIR SPECIFICATIONS (Continued)

Piston Assembly (Continued)

Piston-To-Cylinder Bore Clearance 0.110—0.151 mm (0.0043—0.0059 in.)

Connecting Rod

Connecting Rod Cap Screw Torque 20 N•m (177 lb-in.)

Crankshaft Bearing I.D. (Maximum)

Standard 41.07 mm (1.617 in.)

Undersized 40.56 mm (1.597 in.)

Piston Pin Bearing I.D. (Maximum)

Early Models 22.06 mm (0.869 in.)

Late Models 19.051 mm (0.750 in.)

Piston Rings

Ring Thickness—Top and Second Rings (Minimum) 1.94 mm (0.076 in.)

Ring End Gap (Minimum) 0.18 mm (0.007 in.)

Ring End Gap (Maximum)

Compression Rings—Top and Second

Early Model 0.90 mm (0.035 in.)

Late Model 1.50 mm (0.059 in.)

Oil Ring Side Rails 1.30 mm (0.051 in.)

Camshaft

Axial Play

FC540V (Serial Number - 014454 Only) 0.07—0.19 mm (0.0028—0.0075 in.)

End Journal O.D.—Cylinder Block (Minimum)

FC420V 19.912 mm (0.7839 in.)

FC540V 20.912 mm (0.8233 in.)

End Journal O.D.—Crankcase Cover (Minimum)

FC420V 20.912 mm (0.8233 in.)

FC540V 20.912 mm (0.8233 in.)

Lobe Height (Minimum)

FC420V 36.75 mm (1.447 in.)

FC540V 37.10 mm (1.461 in.)

Bearing I.D.—Cylinder Block (Maximum)

FC420V 20.076 mm (0.7904 in.)

FC540V 21.076 mm (0.8298 in.)

Bearing I.D.—Crankcase Cover (Maximum)

FC420V 21.076 mm (0.8298 in.)

FC540V 21.076 mm (0.8298 in.)

ACR Tappet Lift (Minimum) 0.6 mm (0.024 in.)

ACR Disengagement 600–900 rpm

Reciprocating Balancer

Support Shaft Nut Torque 7 N•m (65 lb-in.)

Link Rod

Journal O.D.—On Crankshaft (Minimum)

FC420V 53.950 mm (2.1240 in.)

FC540V 57.941 mm (2.2811 in.)

Wrist Pin Bearing I.D. (Maximum) 12.601 mm (0.4961 in.)

Collar Bearing I.D. (Maximum)

FC420V 54.121 mm (2.1307 in.)

FC540V 58.153 mm (2.2895 in.)

Bearing Installation Depth Below Surface (Both Ends) 1.0 mm (0.0394 in.)

Balance Weight

Bearing I.D. (Maximum) 26.097 mm (1.0274 in.)

Bearing Installation Depth (Below Surface) 0.50 mm (0.0197 in.)

Support Shaft

Shaft O.D. (Minimum) 25.927 mm (1.0208 in.)



REPAIR SPECIFICATIONS (Continued)**Crankshaft**

Total Indicated Runout (TIR) 0.05 mm (0.002 in.)

Main Bearing Journal O.D.—Crankcase Cover Side (Minimum)

FC420V 34.919 mm (1.3747 in.)

FC540V 37.904 mm (1.4923 in.)

Main Bearing Journal O.D.—Cylinder Block Side (Minimum)

Both Engines 34.945 mm (1.3757 in.)

Connecting Rod Journal O.D. (Minimum)

Standard 40.928 mm (1.6113 in.)

Undersized 40.47—40.48 mm (1.5932—1.5937 in.)

Crankcase Cover Crankshaft Bearing I.D. (Maximum)

FC420V 35.069 mm (1.3807 in.)

FC540V 38.056 mm (1.4983 in.)

Oil Seal Installation Depth

Both Sides/Both Engines flush with surface

Oil Filter Manifold Cap Screw Torque 17 N•m (150 lb-in.)

Oil Pump**Rotor Shaft O.D. (Minimum)**

FC420V (Large O.D.) 12.627 mm (0.4971 in.)

FC420V (Small O.D.) 7.935 mm (0.3125 in.)

FC540V 12.627 mm (0.4971 in.)

Rotor Shaft Bearing I.D. (Maximum)

Both Engines (Oil Pump Cover) 12.76 mm (0.5024 in.)

FC420V (Crankcase Cover) 8.07 mm (0.3177 in.)

FC540V (Crankcase Cover) 12.76 mm (0.5023 in.)

Outer Rotor**FC420V**

Minimum Thickness 11.92 mm (0.4692 in.)

Minimum O.D. 28.95 mm (1.1397 in.)

FC540V

Minimum Thickness 9.92 mm (0.3905 in.)

Minimum O.D. 40.47 mm (1.5933 in.)

Outer Rotor Bearing Housing**FC420V**

Maximum Depth 12.14 mm (0.4779 in.)

Maximum I.D. 29.20 mm (1.1496 in.)

FC540V

Maximum Depth 10.17 mm (0.4003 in.)

Maximum I.D. 40.77 mm (1.6051 in.)

Relief Valve Spring Free Length (Minimum) 19.00 mm (0.7480 in.)

Governor

Governor Mounting Shaft Height 32.2—32.8 mm (1.267—1.291 in.)

Governor Lever Nut Torque 7.8 N•m (69 lb-in.)

Engine Mounting Cap Screw Torque 16.7—22.6 N•m (148.0—200.0 lb-in.)

Blower Housing Cap Screw Torque 10 N•m (89 lb-in.)

Blower Housing To Flywheel Screen Gap (Minimum) 1.5 mm (0.059 in.)

Flywheel Screen To Cooling Fan Cap Screw Torque 6 N•m (53 lb-in.)

Cooling Fan To Flywheel Cap Screw Torque 10 N•m (89 lb-in.)

Cooling Fan Bracket To Flywheel Cap Screw Torque 12 N•m (102 lb-in.)

Flywheel Mounting Nut Torque

FC420V 137 N•m (101 lb-ft)

FC540V 172 N•m (127 lb-ft)

Oil Drain Plug Torque 23 N•m (200 lb-in.)



REPAIR SPECIFICATIONS (Continued)

Stator

Cap Screw Torque 6 N•m (53 lb-in.)

Ignitor Module

All Engines Prior To:

FC420V-DS10 (FC420VB50633—)

FC540V-DS15 (FC540VA00385—)

No Specifications. replace with known good ignitor module

Magneto Ignition Coil

All Engines Prior To and Including:

FC420V-DS10 (—FC420VB50633)

FC540V-DS15 (—FC540VA00385)

Resistance Between Primary Lead and Core 0.48—0.72 ohms

Resistance Between Plug Cap and Core 10.9—16.3 K ohms

Air Gap 0.30 mm (0.012 in.)

Cap Screw Torque 6 N•m (53 lb-in.)

Magneto Ignition Coil With Ignitor Module

All Engines After and Including:

FC420V-DS10 (FC420VB50633—)

FC540V-DS15 (FC540VA00385—)

Resistance Between Primary Lead and Core 0.48—0.72 ohms

Resistance Between Plug Cap and Core

With Standard Plug 8.7—13.1 K ohms ±10%

With Resistor Plug 18.0—19.0 K ohms ±10%

Air Gap 0.30 mm (0.012 in.)

Cap Screw Torque 6 N•m (53 lb-in.)

Starter

Maximum Amperage (No Load) 50 amps at 6000 rpm

Minimum Starter Brush Length

FC420V 6 mm (0.240 in.)

FC540V 10.5 mm (0.413 in.)

Starter-To-Engine Mounting Cap Screw Torque 16 N•m (142 lb-in.)

Starter End Cover Cap Screw Torque. 9 N•m (80 lb-in.)



SPECIAL OR ESSENTIAL TOOLS

NOTE: Order tools according to information given in the U.S. SERVICEGARD™ Catalog or in the European Microfiche Tool Catalog (MTC).

JT07270 Digital Pulse Tachometer
Used to check SLOW and FAST idle speeds and starter performance.

JDM59 Compression Gauge
Used to check engine compression.

JT05697 Manometer Kit
Contains #5 plug and the following:

Barb Fitting
Used to connect U-tube manometer to engine for Crankcase Vacuum Test.

Line
Used to connect U-tube manometer to engine for Crankcase Vacuum Test.

U-Tube Manometer
Used to check crankcase vacuum.

JT03503 Crankcase Vacuum Gauge Test Kit
Used to check crankcase vacuum.

JT03338 90° Elbow Fitting
Used to connect pressure gauge to engine when performing Engine Oil Pressure Test.

JT03344 Pressure Gauge Assembly
Used to read engine oil pressure when performing Engine Oil Pressure Test.

JT03017 Hose Assembly
Used to connect pressure gauge to engine when performing Engine Oil Pressure Test.

JDG356 Pressure Gauge
Used to check fuel pump performance.

D-05351ST Spark Tester
Used to check overall condition of ignition system.

JDM70 Valve Spring Compressor
Used to remove and install valve springs.

JDG504 Valve Guide Driver Tool
Used to replace valve guide bushings.

JT05791 Digital Analog Multimeter and JT02153 Current Clamp-on Tester
Used to check starter performance and condition of ignition system components.

D-05351ST Spark Tester
Used to visually check for spark.



OTHER MATERIALS

Number	Name	Use
M79292	MPG-2 [®] Multipurpose Polymer Grease SCOTCH-BRITE [®] Abrasive Sheets/Pads Valve Guide Cleaner Stanisol (or Kerosene) Prussian Blue Compound Lithium Base Grease Zinc Oxide/Wood Alcohol Mineral Spirits	Apply to engine crankshaft. Clean cylinder head. Clean valve guides. Finish ream valve guides. Check valve seat contact. Pack oil seals. Check block for cracks. Clean armature.
T43512	John Deere Thread Lock and Sealer (Medium Strength)	Retains cap screws.
TY9375/TY9480/592	Pipe Sealant with TEFLON [®]	Apply to threads of oil pressure switch.

SERVICE PARTS KITS

The following kits are available through your parts catalog:

- Fuel Pump Gasket Kit
- Carburetor
- Gasket Kit
- Vent Kit
- Jet Kit
- Choke Shaft Kit
- Throttle Shaft Kit
- Breather Valve Kit
- Air Cleaner Assembly
- Blower Housing Engine Cover Kit
- Flywheel Screen and Spacer Kit
- Dipstick Tube Kit
- Rocker Arm and Shaft Kit
- Intake Valve Kit
- Exhaust Valve Kit
- Camshaft and Tappet Kit
- Camshaft Axial Play Shim Kit
- Piston Ring Kit
- Oversized Piston
- Oversized Piston Ring Kit
- Undersized Connecting Rod
- Crankshaft End Play Shim Kit
- Cylinder Block
- Overhaul Gasket Kit
- Short Block Kit
- Oil Pump Kit
- Governor and Shaft Kit

MPG-2[®] is a registered trademark of DuBois USA.
SCOTCH-BRITE[®] is a registered trademark of the 3M Co.
TEFLON[®] is a registered trademark of the DuPont Co.

COMPONENT LOCATION

EXTERNAL ENGINE COMPONENTS

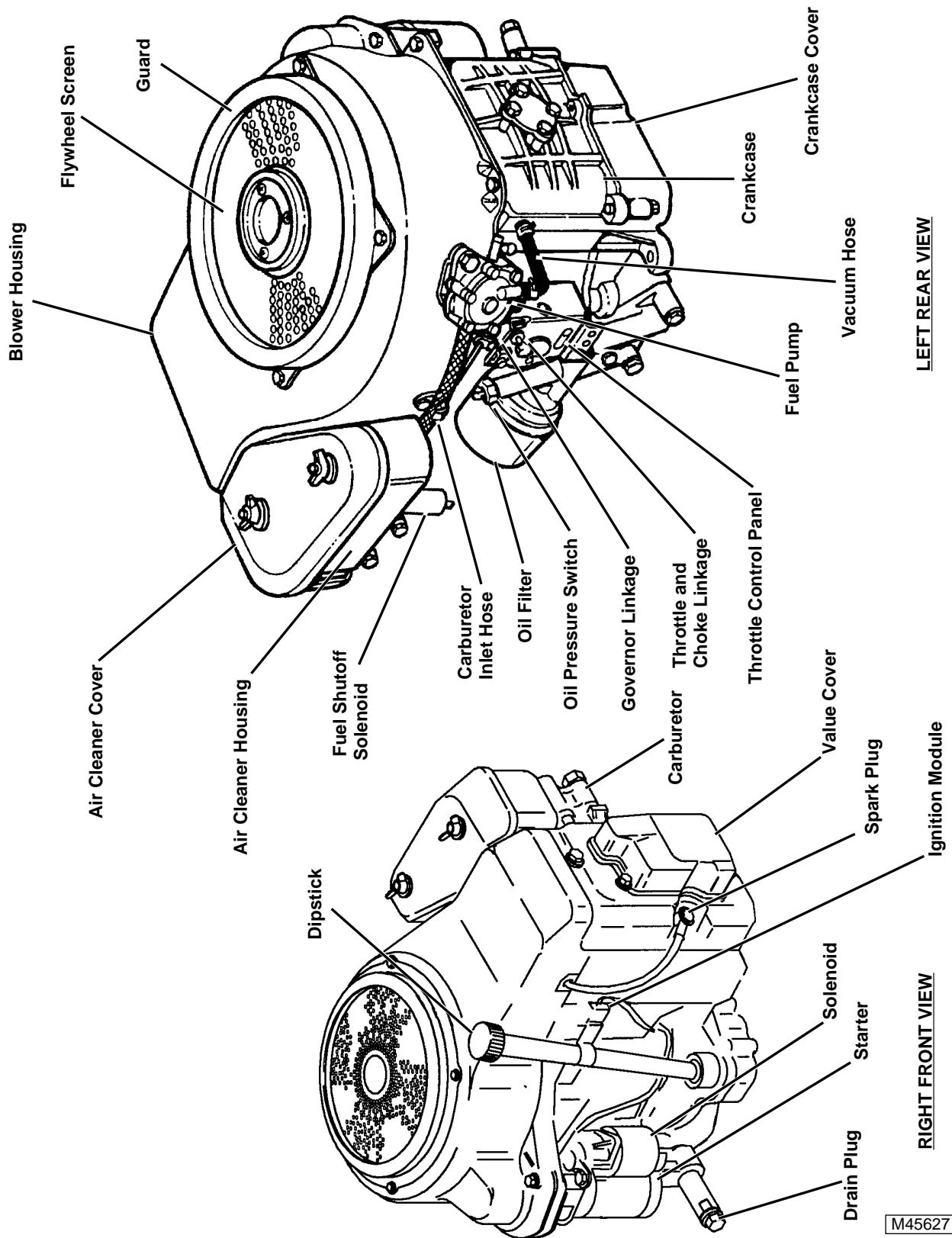

M45627

INTERNAL ENGINE COMPONENTS

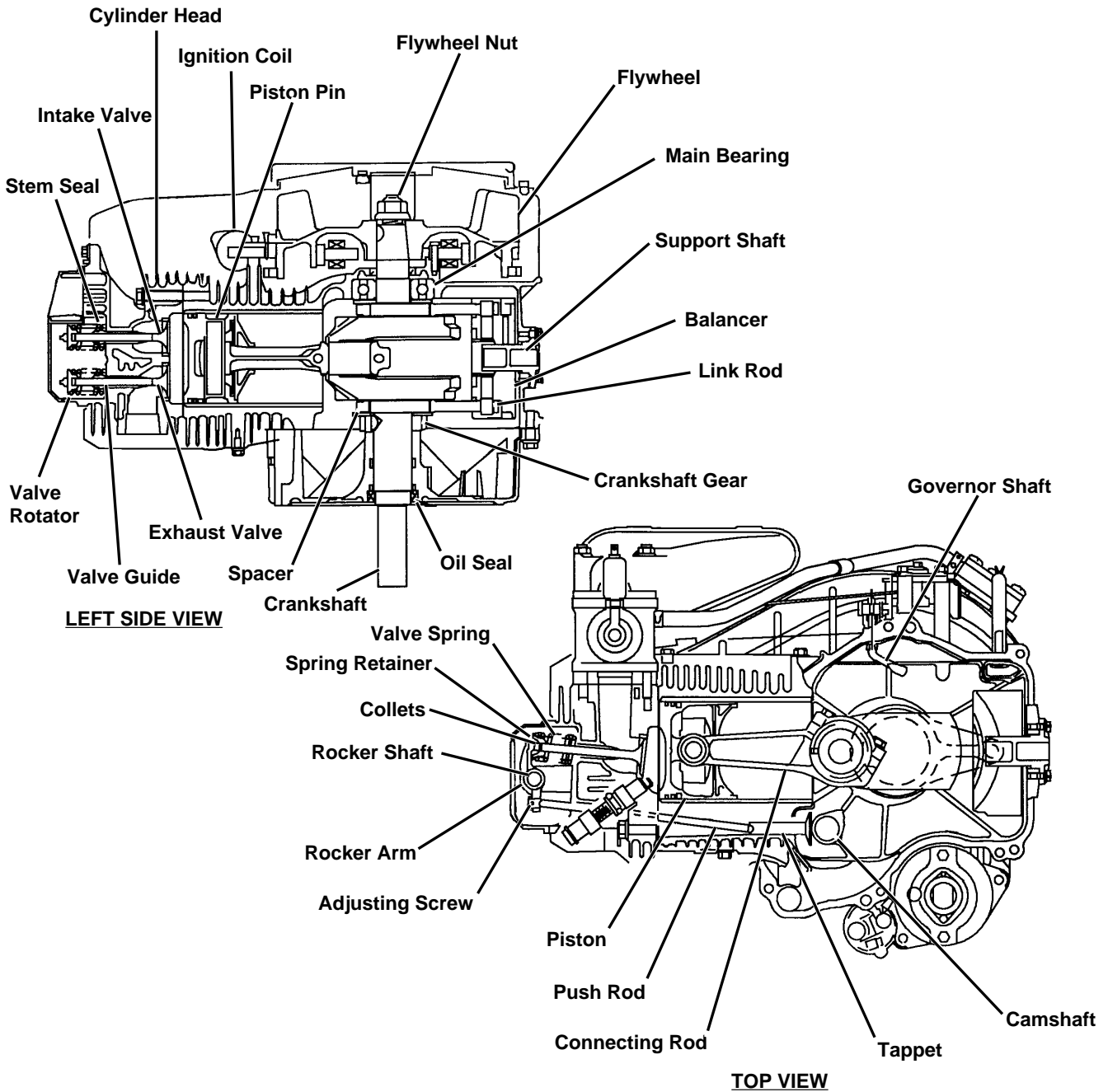

M45811

OIL PUMP BREATHER AND COMPRESSION RELEASE COMPONENTS

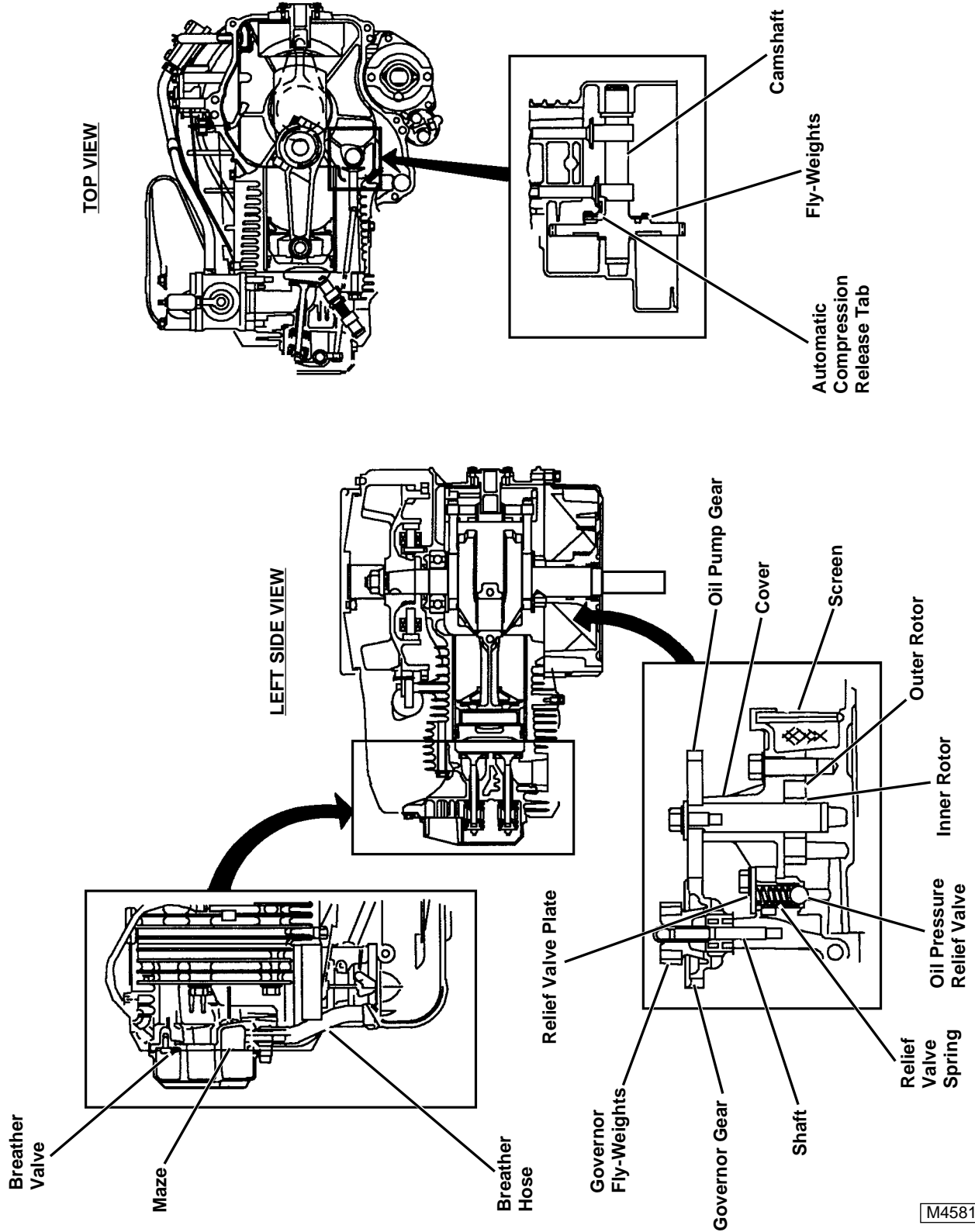

FUEL AND AIR SYSTEM COMPONENTS

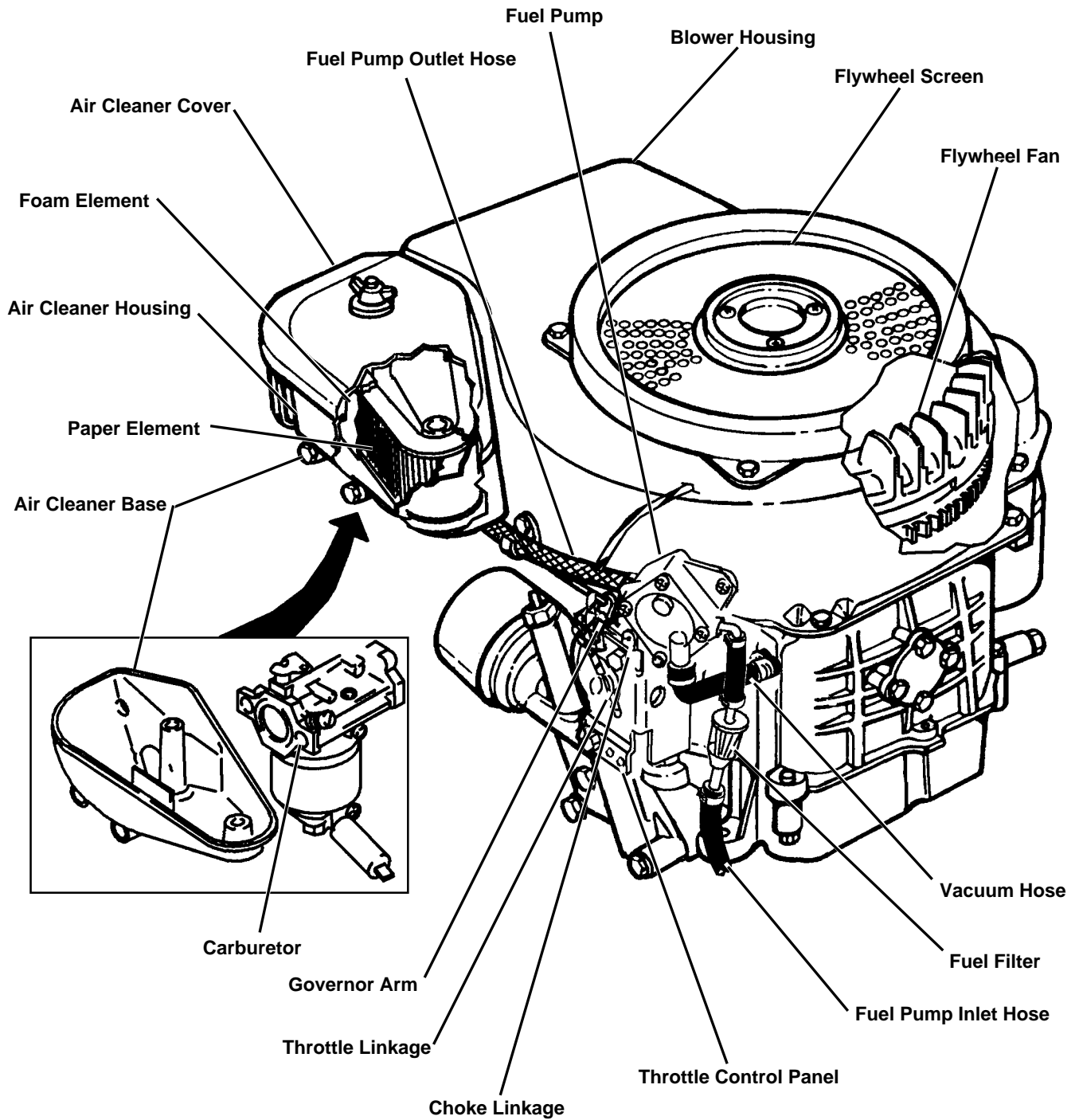

LEFT REAR VIEW

M45665

THEORY OF OPERATION

LUBRICATION SYSTEM OPERATION

Function:

To provide pressurized oil to lubricate internal engine components.

Theory of Operation:

A positive displacement gerotor pump is used to pressurize the lubrication system. The oil pump is driven directly off the crankshaft gear. The lubrication system is protected by an oil pressure relief valve, low oil pressure switch, and an oil filter with bypass.

The oil pump draws oil from the sump through the pick-up screen. Pressure oil from the pump flows through the pump outlet passage past the oil pressure relief valve. The oil pressure relief valve limits the oil pressure to approximately 296 kPa (43 psi) and protects the oil pump from damage if an oil passage becomes blocked. If oil pressure exceeds 296 kPa (43 psi), the relief valve opens allowing oil to return to sump. Relief valve is not adjustable.

Pressure oil from the relief valve flows to the oil filter. The filter contains a bypass valve which opens if the element becomes plugged to ensure engine lubrication.

An oil pressure switch mounted in the oil filter manifold turns on a warning light if oil pressure is below 28 kPa (4 psi). Filtered pressure oil flows through a passage in the oil sump to the crankshaft main bearing (PTO side) and then to the camshaft bearing. Drilled passages in the crankshaft distribute oil from the main bearings to the lower balancer link, connecting rod journal, upper balancer link, and crankshaft ball bearing (flywheel side). A drilled passage in the connecting rods allow oil from the connecting rod journal to lubricate the piston and cylinder walls.

Pressure-free oil flowing out of the crankshaft ball bearing or upper balancer link also lubricates the balancer. A drilled passage in the top of the balancer allows oil to flow to the support shaft and balancer bushing.

The rocker arms, valves, and pushrods are lubricated by an oil/air mixture and carried to the rocker arm cover through the breather passage. The breather passage is located directly above the upper pushrod. The oil from the oil/air mixture is separated from the air through the breather maze and flows to the bottom of the cylinder head. This oil drains back to the sump through an oil return passage located in the bottom of the cylinder block directly under the lower pushrod.



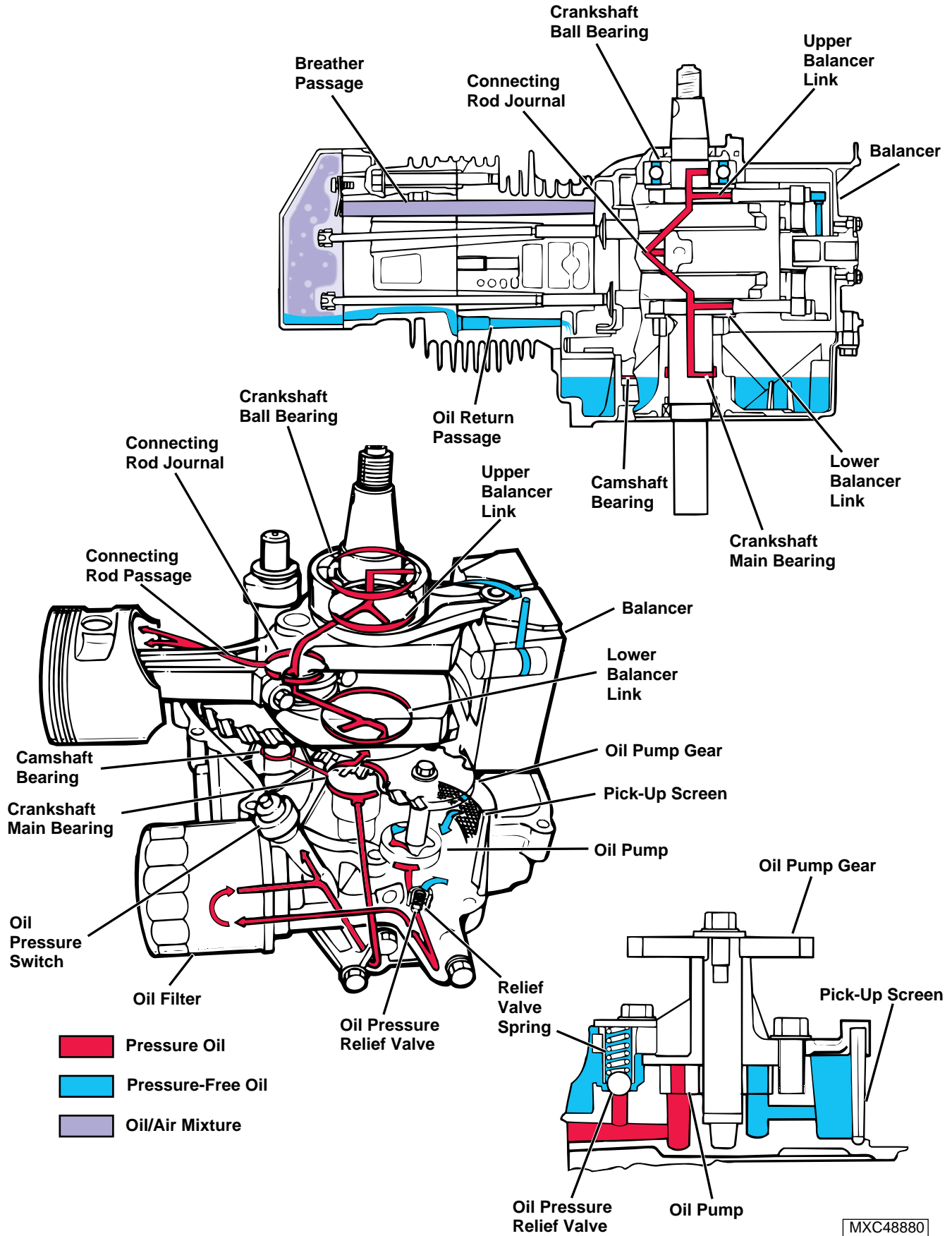

COOLING SYSTEM OPERATION

Function:

Remove heat from engine.

Theory of Operation:

The engine is air-cooled with air flow provided by a fan that is part of the flywheel. During operation, the fan draws air in through the intake screen. The intake screen rotates and cuts debris into small pieces to help prevent the cooling fins from plugging. The blower housing and cylinder block cover direct the air flow past the cooling fins of the cylinder block and head. Most of the cooling air flows directly over the valve area. This

increased cooling capacity in the valve area helps to minimize valve sticking and seat wear due to overheating. The cooling fins are cast into the engine block and cylinder head to increase their surface area to allow more of the heat generated by the engine to be transferred to the cooling air.

It is important that the intake screen remains free of debris for proper air flow. The engine covers should not be removed or altered, as cooling capacity will be reduced. Cylinder block and head cooling fins must remain clean to properly dissipate heat. Debris build-up on the intake screen or fins will affect the volume of air to the carburetor.



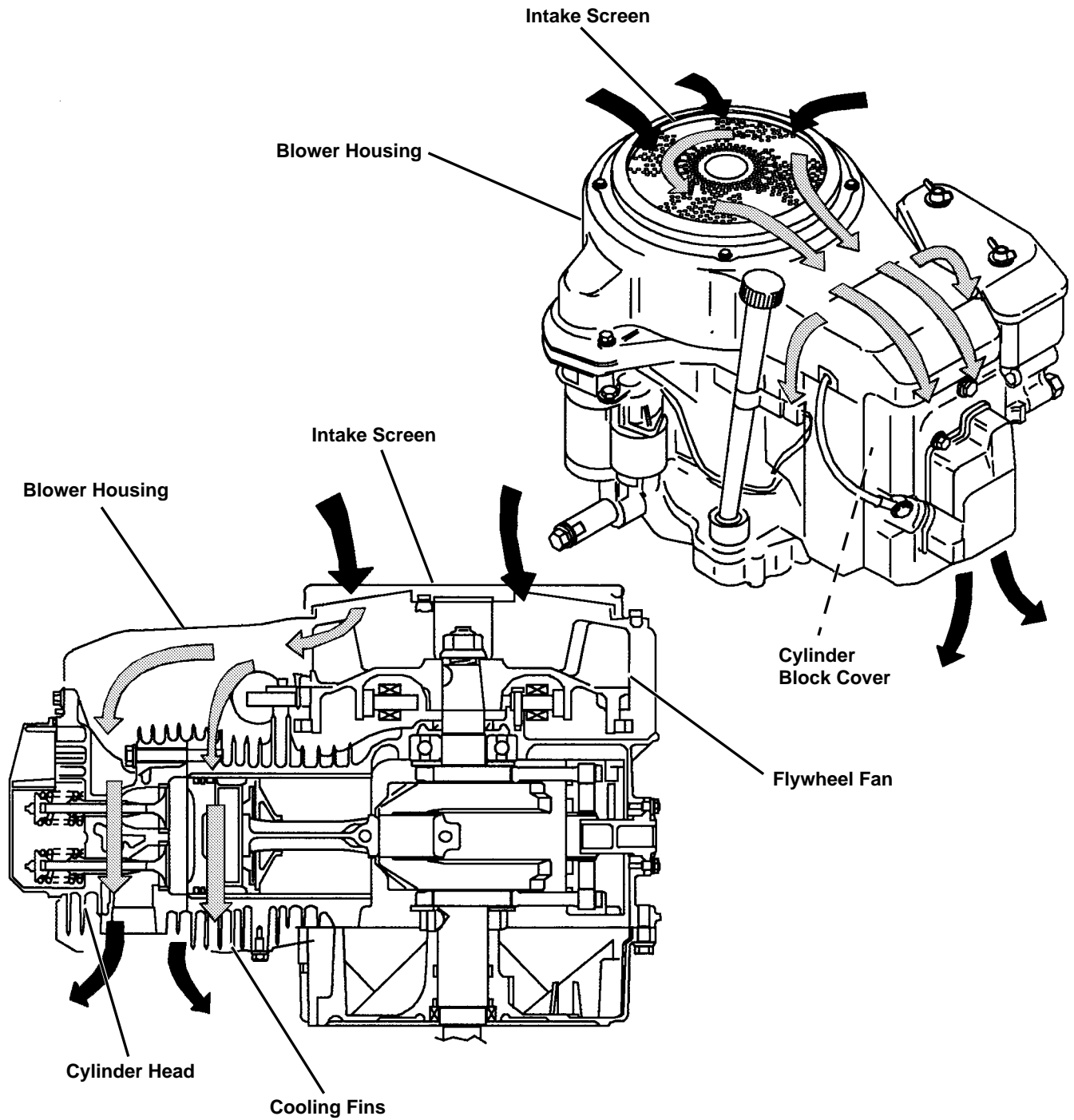

M45628



Suggest:

If the above button click is invalid.

Please download this document

first, and then click the above link

to download the complete manual.

Thank you so much for reading

TROUBLESHOOTING

ENGINE AND FUEL SYSTEM TROUBLESHOOTING CHART

<p>PROBLEM OR SYMPTOM</p> <p>CHECK OR SOLUTION</p>	Engine cranks but will not start or starts hard	Engine will not stay running, runs rough, or irrationally	Engine dies frequently	Engine backfires (afterbang)	Engine surges, or has uneven or uncontrolled rpm	Engine has low power	Engine has no spark	Engine will not crank	Lack of fuel in carburetor	Engine floods	Exhaust smoke black or uses too much fuel	Exhaust smoke blue or has excessive oil consumption	Engine has low oil pressure	Fuel in oil	Engine overheats	Excessive engine noise or vibration
Spark plug fouled, defective, or gap not correct. Incorrect spark plug	●	●				●	●			●	●			●	●	
Defective ignition components	●	●	●	●	●	●	●			●	●			●		
Starter worn. Cranking rpm too slow	●							●								
Fuel filter or line restricted. Fuel pump weak, restricted, or leaking. Fuel stale, contains water, or wrong type	●	●	●	●	●	●			●		●	●				
Fuel pump not operating	●	●							●							
Air filter element(s) plugged, oil soaked, or restricted	●	●			●	●				●	●			●		
Choke, throttle, or governor linkage misadjusted. Carburetor misadjusted	●	●	●	●	●	●			●	●	●			●		
Carburetor worn, contaminated with debris or varnish. Passages plugged. Wrong jets	●	●	●	●	●	●			●					●		
Carburetor, intake & exhaust manifold, or cylinder head gaskets leaking or damaged	●	●		●	●	●										●
Low compression from worn piston, rings, cylinder, valves or warped head	●	●				●						●		●		●



<https://www.ebooklibonline.com>

Hello dear friend!

Thank you very much for reading.

Enter the link into your browser.

The full manual is available for immediate download.

<https://www.ebooklibonline.com>