

F510 and F525 Residential Front Mowers

**John Deere Horicon Works
TM1475 (23OCT95)**

LITHO IN U.S.A.
ENGLISH

**F510 and F525 Residential
Front Mowers**

TM1475 (23OCT95)



Introduction

FOREWORD

This manual is written for an experienced technician. Essential tools required in performing certain service work are identified in this manual and are recommended for use.

Live with safety: Read the safety messages in the introduction of this manual and the cautions presented throughout the text of the manual.



This is the safety-alert symbol. When you see this symbol on the machine or in this manual, be alert to the potential for personal injury.

Technical manuals are divided in two parts: repair and operation and tests. Repair sections tell how to repair the components. Operation and tests sections help you identify the majority of routine failures quickly.

Information is organized in groups for the various components requiring service instruction. At the beginning of each group are summary listings of all applicable essential tools, service equipment and tools, other materials needed to do the job, service parts kits, specifications, wear tolerances, and torque values.

Technical Manuals are concise guides for specific machines. They are on-the-job guides containing only the vital information needed for diagnosis, analysis, testing, and repair.

Fundamental service information is available from other sources covering basic theory of operation, fundamentals of troubleshooting, general maintenance, and basic type of failures and their causes.

<https://www.ebooklibonline.com>

Hello dear friend!

Thank you very much for reading.

Enter the link into your browser.

The full manual is available for immediate download.

<https://www.ebooklibonline.com>

JOHN DEERE DEALERS

This is a complete revision for TM1475—F510 and F525 Residential Front Mowers.

Discard TM1475 dated (01MAY92) and replace with this manual.

New information added to this manual includes:

1. Updated engine repair procedures and specifications.
2. New engine adjustment procedures.
3. New electrical wiring harness diagrams.
4. New electrical schematics and diagnostic diagrams.
5. Updated electrical tests.
6. New mower deck repair procedures.
7. New lift linkage repair procedures.
8. New snowthrower repair information.
9. New snowthrower diagnostic information.
10. New snowthrower adjustment procedures.
11. New Power Flow™ repair information.
12. New Power Flow™ diagnostic information.

Contents

SECTION 10—GENERAL INFORMATION

- Group 05—Safety
- Group 10—General Specifications
- Group 15—Repair Specifications
- Group 20—Fuel and Lubricants
- Group 25—Serial Number Location

SECTION 20—ENGINE REPAIR

- Group 05—Remove and Install Engine
- Group 10—Blower Housing and Flywheel
- Group 15—Cylinder Head and Valves
- Group 20—Cylinder Block and Internal Components

SECTION 30—FUEL AND AIR SYSTEM REPAIR

- Group 05—Fuel Tank
- Group 10—Fuel Pump
- Group 15—Air Cleaner
- Group 20—Carburetor

SECTION 40—ELECTRICAL REPAIR

- Group 05—Electric PTO Clutch
- Group 10—Starter
- Group 15—Ignition and Charging System

SECTION 50—POWER TRAIN REPAIR

- Group 10—Hydrostatic Transmission and Differential

SECTION 60—STEERING REPAIR

- Group 05—Steering Shaft and Gears
- Group 10—Wheels

SECTION 65—BRAKE REPAIR

- Group 05—Brake Repair

SECTION 80—MISCELLANEOUS

- Group 05—Mower Deck Repair
- Group 10—Blade Drive Belt
- Group 15—38-Inch Snowthrower
- Group 20—Power Flow™ Blower Assembly
- Group 25—Engine Shroud and Fenders
- Group 30—Weight Transfer System

SECTION 210—SPECIFICATIONS/OPERATIONAL CHECKOUT PROCEDURE

- Group 05—Operational Checkout Procedure
- Group 10—Test and Adjustment Specifications

SECTION 220—ENGINE OPERATION, TESTS, AND

- Group 05—Engine Component Location
- Group 10—Theory of Operation
- Group 15—Diagnosis, Tests, and Adjustments

SECTION 230—FUEL/AIR OPERATION, TESTS, AND ADJUSTMENTS

- Group 05—Component Location
- Group 10—Theory of Operation
- Group 15—Diagnosis, Tests, and Adjustments

SECTION 240—ELECTRICAL SYSTEM OPERATION, TESTS, AND ADJUSTMENTS

- Group 05—Component Location
- Group 10—Theory of Operation
- Group 15—Diagnosis, Tests, and Adjustments
- Group 20—Wiring Schematic and Harness Diagram

SECTION 250—POWER TRAIN OPERATION, TESTS, AND ADJUSTMENTS

- Group 05—Power Train Component Location
- Group 10—Theory of Operation
- Group 15—Power Train Diagnosis

SECTION 260—STEERING OPERATION, TESTS, AND ADJUSTMENTS

- Group 05—Component Location
- Group 10—Theory of Operation
- Group 15—Diagnostics
- Group 20—Adjustments

SECTION 265—BRAKE OPERATION, TESTS, AND ADJUSTMENTS

- Group 05—Component Location
- Group 10—Theory of Operation

Continued on next page

All information, illustrations and specifications in this manual are based on the latest information available at the time of publication. The right is reserved to make changes at any time without notice.

TM1475-19-23OCT95

COPYRIGHT© 1995
DEERE & COMPANY
Moline, Illinois
All rights reserved
A John Deere ILLUSTRATION™ Manual
Previous Editions
Copyright 1992, 1989 Deere & Company

Group 15—Diagnostics
Group 20—Adjustments

10

**SECTION 280—MISCELLANEOUS OPERATION,
TESTS, AND ADJUSTMENTS**

Group 05—Component Location
Group 10—Theory of Operation
Group 15—Diagnosis and
Adjustments—Snowthrower
Group 20—Diagnosis—Power Flow™ Blower
Assembly

20

30

Index

40

50

60

65

80

210

220

Section 10 GENERAL INFORMATION

Contents

Page

Group 05—Safety 10-05-1

Group 10—General Specifications

Machine Specifications 10-10-1

Group 15—Repair Specifications

Engine Configuration Chart 10-15-1

Repair Specifications 10-15-2

Tune-Up Adjustments 10-15-13

Metric Cap Screw Torque Values 10-15-14

Inch Cap Screw Torque Values 10-15-15

Group 20 —Fuel and Lubricants

Group 25—Serial Number Location

Serial Number Information 10-25-1

Product Identification Number 10-25-1

Engine Serial Number 10-25-1

RECOGNIZE SAFETY INFORMATION

This is the safety-alert symbol. When you see this symbol on your machine or in this manual, be alert to the potential for personal injury.

Follow recommended precautions and safe operating practices.

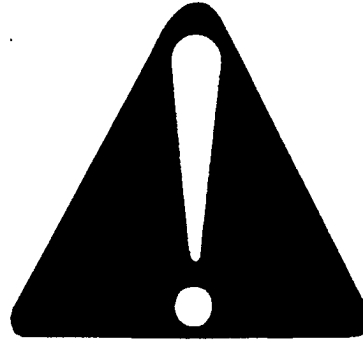

DX,ALERT -19-03MAR93

10
05
1
-UN-07DEC88
T81389

UNDERSTAND SIGNAL WORDS

A signal word—DANGER, WARNING, or CAUTION—is used with the safety-alert symbol. DANGER identifies the most serious hazards.

DANGER or WARNING safety signs are located near specific hazards. General precautions are listed on CAUTION safety signs. CAUTION also calls attention to safety messages in this manual.



DX,SIGNAL -19-03MAR93

-19-30SEP88
TS187

FOLLOW SAFETY INSTRUCTIONS

Carefully read all safety messages in this manual and on your machine safety signs. Keep safety signs in good condition. Replace missing or damaged safety signs. Be sure new equipment components and repair parts include the current safety signs. Replacement safety signs are available from your John Deere dealer.

Learn how to operate the machine and how to use controls properly. Do not let anyone operate without instruction.

Keep your machine in proper working condition. Unauthorized modifications to the machine may impair the function and/or safety and affect machine life.

If you do not understand any part of this manual and need assistance, contact your John Deere dealer.



DX,READ -19-03MAR93

-UN-23AUG88
TS201

HANDLE FLUIDS SAFELY—AVOID FIRES

When you work around fuel, do not smoke or work near heaters or other fire hazards.

Store flammable fluids away from fire hazards. Do not incinerate or puncture pressurized containers.

Make sure machine is clean of trash, grease, and debris.

Do not store oily rags; they can ignite and burn spontaneously.



DX,FLAME -19-04JUN90

-UN-23AUG88
TS227

PREVENT BATTERY EXPLOSIONS

Keep sparks, lighted matches, and open flame away from the top of battery. Battery gas can explode.

Never check battery charge by placing a metal object across the posts. Use a volt-meter or hydrometer.

Do not charge a frozen battery; it may explode. Warm battery to 16°C (60°F).



DX,SPARKS -19-03MAR93

-UN-23AUG88
TS204

PREPARE FOR EMERGENCIES

Be prepared if a fire starts.

Keep a first aid kit and fire extinguisher handy.

Keep emergency numbers for doctors, ambulance service, hospital, and fire department near your telephone.

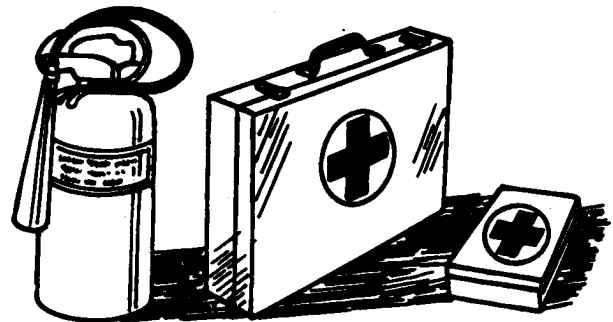

DX,FIRE2 -19-03MAR93

-UN-23AUG88
TS291

PREVENT ACID BURNS

Sulfuric acid in battery electrolyte is poisonous. It is strong enough to burn skin, eat holes in clothing, and cause blindness if splashed into eyes.

Avoid the hazard by:

1. Filling batteries in a well-ventilated area.
2. Wearing eye protection and rubber gloves.
3. Avoiding breathing fumes when electrolyte is added.
4. Avoiding spilling or dripping electrolyte.
5. Use proper jump start procedure.

If you spill acid on yourself:

1. Flush your skin with water.
2. Apply baking soda or lime to help neutralize the acid.
3. Flush your eyes with water for 15—30 minutes. Get medical attention immediately.

If acid is swallowed:

1. Do not induce vomiting.
2. Drink large amounts of water or milk, but do not exceed 2 L (2 quarts).
3. Get medical attention immediately.

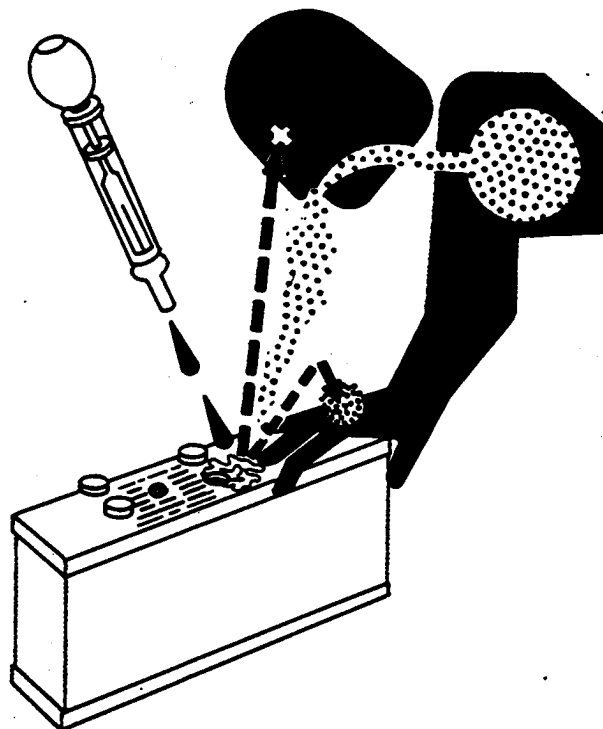

DX,POISON -19-21APR93

T5203 -UN-23AUG88

HANDLE CHEMICAL PRODUCTS SAFELY

Direct exposure to chemical products can cause severe skin irritation and injury. Hazardous fumes can be generated when handling the chemicals.

Wear close fitting clothing and a face mask when handling chemicals. Dispose of chemical waste and packaging material properly.

A Material Safety Data Sheet provides specific details on chemical products and physical dangers, safety procedures, and emergency response techniques. User awareness and training is required under U.S. workplace and environmental laws. See your John Deere dealer for information on chemical products used with John Deere equipment.



DX,MSDS -19-28SEP90

T5272 -UN-23AUG88

10
05
4

AVOID HIGH-PRESSURE FLUIDS

Escaping fluid under pressure can penetrate the skin causing serious injury.

Avoid the hazard by relieving pressure before disconnecting hydraulic or other lines. Tighten all connections before applying pressure.

Search for leaks with a piece of cardboard. Protect hands and body from high pressure fluids.

If an accident occurs, see a doctor immediately. Any fluid injected into the skin must be surgically removed within a few hours or gangrene may result. Doctors unfamiliar with this type of injury should reference a knowledgeable medical source. Such information is available from Deere & Company Medical Department in Moline, Illinois, U.S.A.

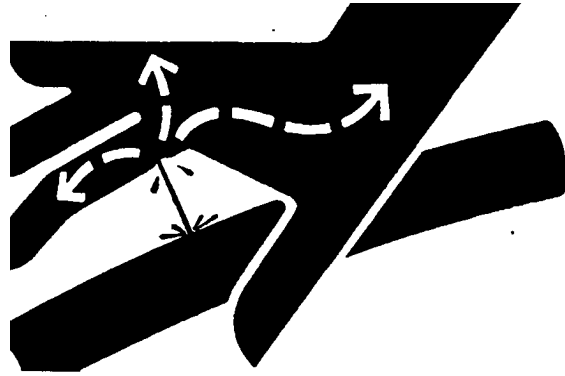

-UN-23AUG88

X9811

DX,FLUID -19-03MAR93

PARK MACHINE SAFELY

Before working on the machine:

- Lower all equipment to the ground.
- Stop the engine and remove the key.
- Disconnect the battery ground strap.
- Hang a "DO NOT OPERATE" tag in operator station.

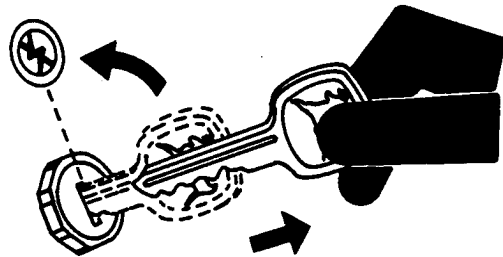

-UN-24MAY89

TS230

DX,PARK -19-04JUN90

SUPPORT MACHINE PROPERLY

Always lower the attachment or implement to the ground before you work on the machine. If you must work on a lifted machine or attachment, securely support the machine or attachment.

Do not support the machine on cinder blocks, hollow tiles, or props that may crumble under continuous load. Do not work under a machine that is supported solely by a jack. Follow recommended procedures in this manual.

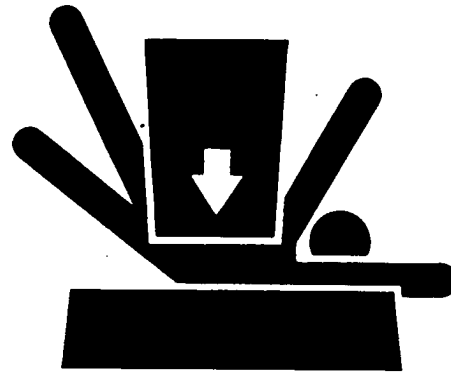

DX,LOWER -19-04JUN90

51910
-UN-23AUG88
TS229

WEAR PROTECTIVE CLOTHING

Wear close fitting clothing and safety equipment appropriate to the job.

Prolonged exposure to loud noise can cause impairment or loss of hearing.

Wear a suitable hearing protective device such as earmuffs or earplugs to protect against objectionable or uncomfortable loud noises.

Operating equipment safely requires the full attention of the operator. Do not wear radio or music headphones while operating machine.

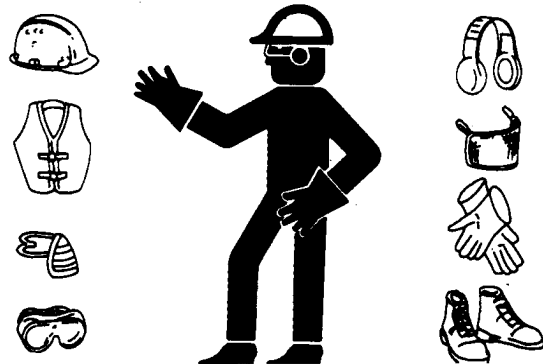

DX,WEAR -19-10SEP90

-UN-23AUG88
TS206

SERVICE MACHINES SAFELY

Tie long hair behind your head. Do not wear a necktie, scarf, loose clothing, or necklace when you work near machine tools or moving parts. If these items were to get caught, severe injury could result.

Remove rings and other jewelry to prevent electrical shorts and entanglement in moving parts.

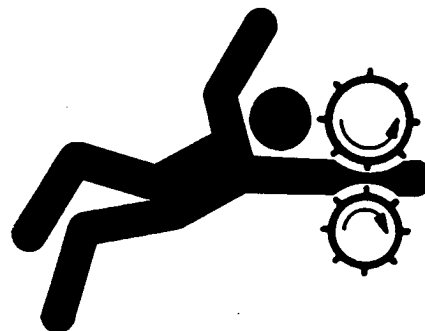

DX,LOOSE -19-04JUN90

-UN-23AUG88
TS228

10
05
6

WORK IN VENTILATED AREA

Engine exhaust fumes can cause sickness or death. If it is necessary to run an engine in an enclosed area, remove the exhaust fumes from the area with an exhaust pipe extension.

If you do not have an exhaust pipe extension, open the doors and get outside air into the area.

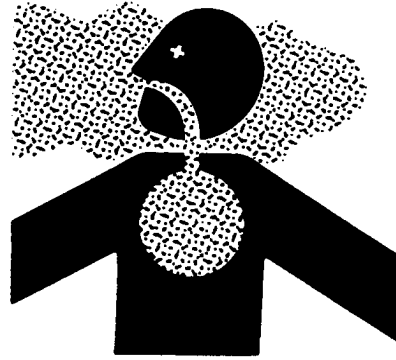

DX,AIR -19-04JUN90

TS220 -UN-23AUG88

WORK IN CLEAN AREA

Before starting a job:

- Clean work area and machine.
- Make sure you have all necessary tools to do your job.
- Have the right parts on hand.
- Read all instructions thoroughly; do not attempt shortcuts.

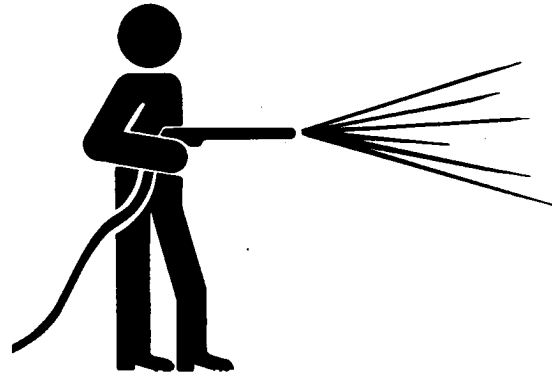

DX,CLEAN -19-04JUN90

T6642EJ -UN-18OCT88

REMOVE PAINT BEFORE WELDING OR HEATING

Avoid potentially toxic fumes and dust.

Hazardous fumes can be generated when paint is heated by welding, soldering, or using a torch.

Do all work outside or in a well ventilated area. Dispose of paint and solvent properly.

Remove paint before welding or heating:

- If you sand or grind paint, avoid breathing the dust. Wear an approved respirator.
- If you use solvent or paint stripper, remove stripper with soap and water before welding. Remove solvent or paint stripper containers and other flammable material from area. Allow fumes to disperse at least 15 minutes before welding or heating.

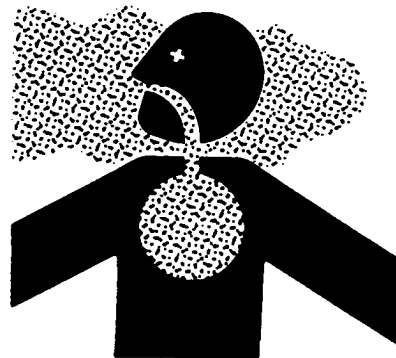

DX,PAINT -19-03MAR93

TS220 -UN-23AUG88

AVOID HEATING NEAR PRESSURIZED FLUID LINES

Flammable spray can be generated by heating near pressurized fluid lines, resulting in severe burns to yourself and bystanders. Do not heat by welding, soldering, or using a torch near pressurized fluid lines or other flammable materials. Pressurized lines can be accidentally cut when heat goes beyond the immediate flame area.



DX,TORCH -19-03MAR93

TS953 -UN-15MAY90

ILLUMINATE WORK AREA SAFELY

Illuminate your work area adequately but safely. Use a portable safety light for working inside or under the machine. Make sure the bulb is enclosed by a wire cage. The hot filament of an accidentally broken bulb can ignite spilled fuel or oil.

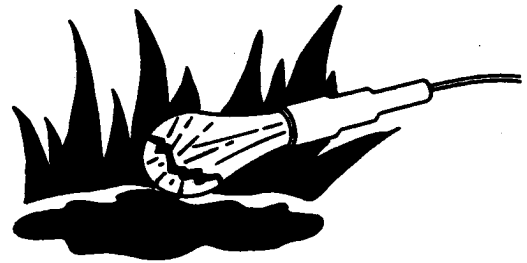

DX,LIGHT -19-04JUN90

TS223 -UN-23AUG88

REPLACE SAFETY SIGNS

Replace missing or damaged safety signs. See the machine operator's manual for correct safety sign placement.



DX,SIGNS1 -19-04JUN90

TS201 -UN-23AUG88

USE PROPER LIFTING EQUIPMENT

Lifting heavy components incorrectly can cause severe injury or machine damage.

Follow recommended procedure for removal and installation of components in the manual.

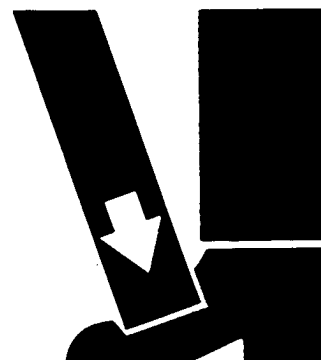

DX,LIFT -19-04JUN90

TS226 -UN-23AUG88

10
05
8

SERVICE TIRES SAFELY

Explosive separation of a tire and rim parts can cause serious injury or death.

Do not attempt to mount a tire unless you have the proper equipment and experience to perform the job.

Always maintain the correct tire pressure. Do not inflate the tires above the recommended pressure. Never weld or heat a wheel and tire assembly. The heat can cause an increase in air pressure resulting in a tire explosion. Welding can structurally weaken or deform the wheel.

When inflating tires, use a clip-on chuck and extension hose long enough to allow you to stand to one side and NOT in front of or over the tire assembly. Use a safety cage if available.

Check wheels for low pressure, cuts, bubbles, damaged rims or missing lug bolts and nuts.



TS952 -UN-12APR90

DX,TIRECP -19-24AUG90

AVOID HARMFUL ASBESTOS DUST

Avoid breathing dust that may be generated when handling components containing asbestos fibers. Inhaled asbestos fibers may cause lung cancer.

Components in products that may contain asbestos fibers are brake pads, brake band and lining assemblies, clutch plates, and some gaskets. The asbestos used in these components is usually found in a resin or sealed in some way. Normal handling is not hazardous as long as airborne dust containing asbestos is not generated.

Avoid creating dust. Never use compressed air for cleaning. Avoid brushing or grinding material containing asbestos. When servicing, wear an approved respirator. A special vacuum cleaner is recommended to clean asbestos. If not available, apply a mist of oil or water on the material containing asbestos.

Keep bystanders away from the area.

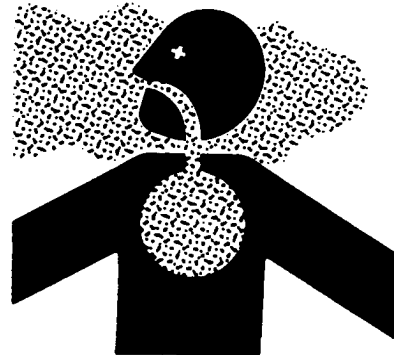

TS220 -UN-23AUG88

DX,DUST -19-15MAR91

PRACTICE SAFE MAINTENANCE

Understand service procedure before doing work. Keep area clean and dry.

Never lubricate, service, or adjust machine while it is moving. Keep hands, feet, and clothing from power-driven parts. Disengage all power and operate controls to relieve pressure. Lower equipment to the ground. Stop the engine. Remove the key. Allow machine to cool.

Securely support any machine elements that must be raised for service work.

Keep all parts in good condition and properly installed. Fix damage immediately. Replace worn or broken parts. Remove any buildup of grease, oil, or debris.

Disconnect battery ground cable (-) before making adjustments on electrical systems or welding on machine.



DX,SERV -19-03MAR93

TS218 -UN-23AUG88

USE PROPER TOOLS

Use tools appropriate to the work. Makeshift tools and procedures can create safety hazards.

Use power tools only to loosen threaded parts and fasteners.

For loosening and tightening hardware, use the correct size tools. DO NOT use U.S. measurement tools on metric fasteners. Avoid bodily injury caused by slipping wrenches.

Use only service parts meeting John Deere specifications.



DX,REPAIR -19-04JUN90

TS779 -UN-08NOV89

10
05
10

DISPOSE OF WASTE PROPERLY

Improperly disposing of waste can threaten the environment and ecology. Potentially harmful waste used with John Deere equipment include such items as oil, fuel, coolant, brake fluid, filters, and batteries.

Use leakproof containers when draining fluids. Do not use food or beverage containers that may mislead someone into drinking from them.

Do not pour waste onto the ground, down a drain, or into any water source.

Air conditioning refrigerants escaping into the air can damage the Earth's atmosphere. Government regulations may require a certified air conditioning service center to recover and recycle used air conditioning refrigerants.

Inquire on the proper way to recycle or dispose of waste from your local environmental or recycling center, or from your John Deere dealer.

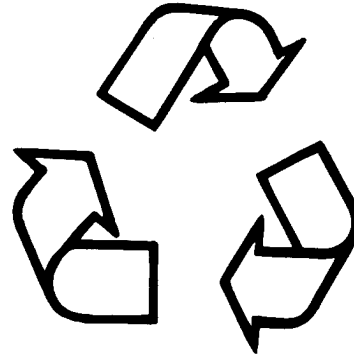

TS1133 -JUN-26NOV90

DX,DRAIN -19-03MAR93

LIVE WITH SAFETY

Before returning machine to customer, make sure machine is functioning properly, especially the safety systems. Install all guards and shields.



TS231 -19-07OCT88

DX,LIVE -19-25SEP92

MACHINE SPECIFICATIONS

	F510	F525
ENGINE	PA420A	PA540A
Manufacturer	KHI	KHI
Cycle	4	4
Output	10.4 kW (14 hp)	12.7 kW (17 hp)
Displacement	423 cc (25.8 cu. in.)	535 cc (32.64 cu. in.)
Cylinders	1	1
Crankshaft Alignment	Vertical	Vertical
Bore	89 mm (3.5 in.)	89 mm (3.5 in.)
Stroke	68 mm (2.68 in.)	86 mm (3.38 in.)
Speed, fast (no load)	3250 ±50 rpm	3250 ±50 rpm
Speed, idle (no load)	1450 rpm	1450 rpm
Ignition	Solid state	Solid state
Starter	Electric	Electric
Cooling	Air	Air
Unitized Eng/Trans		
Oil Reservoir Capacity:		
Without filter	2.4 L (2.5 qt)	2.6 L (2.7 qt)
With filter	2.6 L (2.7 qt)	2.8 L (2.9 qt)
Total system	3.4 L (3.5 qt)	3.9 L (4.1 qt)
Air Cleaner	Dry Replaceable w/foam precleaner	Dry Replaceable w/foam precleaner
POWER TAKE-OFF	Electric	Electric
CONSTRUCTION		
Block	Aluminum	Aluminum
Cylinder Liner	Cast iron	Cast iron
Cylinder Head	Aluminum	Aluminum
ELECTRICAL SYSTEM		
Charging System	Flywheel Alternator; 13 AMP, Regulated	Flywheel Alternator; 15 AMP, Regulated
Battery Voltage	12	12
Reserve Capacity @ 25 Amp	35 minutes	35 minutes
Cold Cranking Amp @ -18°C (0°F)	255	255
Spark Plug	RN11YC or NGK-BPR5ES	RN11YC or NGK-BPR5ES
Plug Gap	0.7-0.8 mm (0.28-0.031 in.)	0.7-0.8 mm (0.28-0.31 in.)
FUEL SYSTEM		
Fuel Tank Location	Left side	Left side
Capacity	10.4 L (2.75 U.S. gal)	10.4 L (2.75 U.S. gal)
Fuel Type	Unleaded Gasoline	Unleaded Gasoline
DRIVE TRAIN		
Transmission Type	Hydrostatic	Hydrostatic
Manufacturer	KHI	KHI
No. of Speeds	Infinite	Infinite
Travel Speeds		
Forward (Max)	8 km/h (5 MPH)	8 km/h (5 MPH)
Reverse (Max)	4 km/h (2.5 MPH)	4 km/h (2.5 MPH)

MX,1010CL,A1 -19-23OCT95

MACHINE SPECIFICATIONS (CONTINUED)

	F510	F525
DRIVE TRAIN-CONTINUED		
Differential	Bevel gear	Bevel gear
Gear Ratio	25:1	25:1
Speed & Direction Control	2 Pedal foot control	2 Pedal foot control
DIMENSIONS		
Height to Top of Steering Wheel	1067 mm (42 in.)	1067 mm (42 in.)
Height to Top of Hood	572 mm (22.5 in.)	572 mm (22.5 in.)
Width		
With 38 in. Mower	1300 mm (50 in.)	
With 46 in. Mower		1448 mm (57 in.)
With 48 in. Mower		1500 mm (59 in.)
Length		
Without Mower	1648 mm (65 in.)	1648 mm (64 in.)
With 38 in. Mower	2100 mm (82 in.)	
With 46 in. Mower		2010 mm (79 in.)
With 48 in. Mower		2000 mm (80 in.)
Ground Clearance	89 mm (3.5 in.)	89 mm (3.5 in.)
Wheelbase	885 mm (35 in.)	885 mm (35 in.)
Min. Turn Radius		
Left Hand	191 mm (7.5 in.)	191 mm (7.5 in.)
TIRES		
Type		
Drive	Soft Track Turf	Soft Track Turf
Steering	Rib	Rib
Size		
Drive	18x8.50-8	18x8.50-8
Steering	13x6.50-6	13x6.50-6
Inflation Pressure		
Drive	96 kPa (14 psi)	96 kPa (14 psi)
Steering	96 kPa (14 psi)	96 kPa (14 psi)
STEERING		
Type	Manual - Rear Wheel	Manual - Rear Wheel
BRAKES		
Type	Internal Wet Band	Internal Wet Band
Location	Internal to Drive	Internal to Drive
FRAME		
	Welded steel	Welded steel
MOWER DECK		
Cutting Width	965 mm (38 in.)	1212 mm (48 in.) or 1168 (46 in.)
Cutting Height	25-89 mm (1-3.5 in.)	25-89 mm (1-3.5 in.)
WEIGHT (APPROX)		
	314 kg (692 lbs)	316 kg (696 lbs) with 46 in. deck 336 kg (740 lbs) with 48 in. deck

(Specifications and design subject to change without notice.)

MX,1010CL,A2 -19-23OCT95

ENGINE CONFIGURATION CHART

The PA420A and PA540A engines have an engine configuration number following the engine model number to help separate engine changes. Use the engine configuration number to determine the proper service specifications and procedures to follow in this technical manual.

ENGINE CONFIGURATION CHART

F510 (Engine S.N. -3887)	PA420A-AS00
(Engine S.N. 3888-4898)	PA420A-BS00
(Engine S.N. 4899-7322)	PA420A-AS01
(Engine S.N. 7323-)	PA420A-AS02
F525 (Engine S.N. -7891)	PA540A-AS00
(Engine S.N. 7892-11999)	PA540A-BS00
(Engine S.N. 12000-21944)	PA540A-AS01
(Engine S.N. 21945-)	PA540A-AS02

MX,1015CL,1 -19-23OCT95

REPAIR SPECIFICATIONS

SECTION 20—ENGINE REPAIR—PA420A

Group 10—Blower Housing and Flywheel

Item	Specification
Flywheel Nut Torque	137 N·m (101 lb-ft)
Minimum Flywheel Screen Gap	1.50 mm (0.059 in.)

Group 15—Cylinder Head and Valves

Item	Specification
Valve Clearance	0.15 mm (0.006 in.)
Breather Air Gap	1—2 mm (0.040—0.080 in.)
Rocker Arm	
Minimum Shaft O.D.	12.94 mm (0.509 in.)
Maximum Bearing I.D.	13.07 mm (0.515 in.)
Push Rod	
Maximum Bend	0.30 mm (0.012 in.)
Valves and Springs	
Minimum Spring Free Length	
PA420A-AS00	37.50 mm (1.476 in.)
PA420A-BS00, AS01 and AS02	35.50 mm (1.398 in.)
Minimum Valve Stem O.D.	
Intake Valve	6.930 mm (0.2728 in.)
Exhaust Valve	6.915 mm (0.2722 in.)
Valve Stem O.D.-New Parts	
Intake Valve	6.972-6.987 mm (0.2745-0.2751 in.)
Exhaust Valve	6.965-6.980 mm (0.2742-0.2748 in.)
Valve Stem to Guide Clearance-New Parts	
Intake Valve	0.013-0.043 mm (0.0005-0.0017 in.)
Exhaust Valve	0.020-0.050 mm (0.0008-0.0020 in.)
Maximum Valve Guide I.D.	7.07 mm (0.278 in.)
Valve Guide I.D.-New Parts	7.000-7.015 mm (0.2756-0.2762 in.)
Valve Stem to Guide Clearance-New Parts	
Intake Valve	0.013-0.043 mm (0.0005-0.0017 in.)
Exhaust Valve	0.020-0.050 mm (0.0008-0.0020 in.)
Valve Guide Bushing Height	
PA420A-BS00, AS01 and AS02	12 mm (0.472 in.)
Valve Guide Bushing Finished I.D.	7.0-7.02 mm (0.275-0.276 in.)
Maximum Valve Stem Bend	0.03 mm (0.001 in.)

Continued on next page

MX,1015CL,1A -19-23OCT95

Group 15—Cylinder Head and Valves—Continued

Item	Specification
Valve Seating Surface	1.10—1.46 mm (0.043—0.057 in.)
Valve Seat and Face Angle	45°
Minimum Valve Margin	0.60 mm (0.020 in.)
Valve Narrowing Angle	30°
Cylinder Head	
Cylinder Head Distortion (Maximum)	0.05 mm
Studs Torque	36 N·m (27 lb-ft)
Cap Screw Torque In Sequence (Lubricated)	
Initial Torque	32 N·m (24 lb-ft)
Final Torque	52 N·m (38 lb-ft)
Spark Plug Torque	20 N·m (177 lb-in.)

Group 20—Cylinder Block and Internal Components

Item	Specification
Crankcase Cover	
Oil Capacity	
Without Filter	2.4 L (2.5 qt)
With Filter	2.6 L (2.7 qt)
Total System	3.4 L (3.5 qt)
Cap Screw Torque PA420A-BS00, AS00 and AS01	23 N·m (204 lb-in.)
Cap Screw Torque PA420A-AS02	29 N·m (257 lb-in.)
Hydrostatic Pump Cover Torque	25 N·m (226 lb-in.)
Oil Drain Plug	24 N·m (217 lb-in.)
Magnet Cap Screw Torque	6 N·m (53 lb-in.)
Camshaft	
Minimum End Journal O.D.	
PTO Side	20.91 mm (0.823 in.)
Flywheel Side	19.91 mm (0.784 in.)
Minimum Lobe Height	36.75 mm (1.447 in.)
Maximum Bearing I.D.	
Crankcase	20.08 mm (0.790 in.)
Crankcase Cover	21.08 mm (0.830 in.)
Reciprocating Balancer	
Link Rod	
Minimum Journal O.D.	53.95 mm (2.124 in.)
Maximum Small End I.D.	12.06 mm (0.475 in.)
Maximum Large End I.D.	54.12 mm (2.131 in.)
Bushing Depth	1.00 mm (0.040 in.)
Balancer Weight	
Maximum Bearing I.D.	26.10 mm (1.027 in.)
Bushing Depth	0.50 mm (0.020 in.)

Continued on next page

MX,1015CL,2 -19-23OCT95

Group 20—Cylinder Block and Internal Components—Continued

Item	Specification
Support Shaft	
Minimum Shaft O.D.	25.93 mm (1.021 in.)
Nuts Torque	7.3 N·m (65 lb-in.)
Piston	
Maximum Ring Groove Clearance	
Top Ring	0.17 mm (0.007 in.)
Second Ring	0.15 mm (0.006 in.)
Oil Ring	0.20 mm (0.008 in.)
Minimum Ring End Gap	0.18 mm (0.007 in.)
Maximum Ring End Gap	
Compression Rings	0.90 mm (0.035 in.)
Oil Ring Side Rails	1.30 mm (0.051 in.)
Minimum Pin O.D.	21.98 mm (0.865 in.)
Maximum Pin Bore I.D.	22.04 mm (0.868 in.)
Maximum Piston-to-Piston Pin Clearance	0.06 mm (0.002 in.)
Piston O.D.	88.83—88.85 mm (3.4885—3.498 in.)
Piston-to-Cylinder Bore Clearance	0.13—0.17 mm (0.005—0.0067 in.)
Connecting Rod	
Maximum Crankshaft Bearing I.D.	41.07 mm (1.617 in.)
Maximum Piston Pin Bearing I.D.	22.06 mm (0.868 in.)
Maximum Connecting Rod-to-Piston Pin Clearance	0.08 mm (0.003 in.)
Maximum Connecting Rod-to-Crankpin Clearance	0.14 mm (0.006 in.)
End-Cap Screw Torque	20 N·m (177 lb-in.)
Crankshaft	
Minimum PTO Side Journal O.D.	34.92 mm (1.375 in.)
Minimum Flywheel Side Journal O.D.	34.95 mm (1.376 in.)
Minimum Connecting Rod Journal O.D.	40.93 mm (1.611 in.)
Maximum Crankcase Cover Plain Bearing I.D.	35.07 mm (1.381 in.)
Ball Bearing O.D.-New Part	79.98-80.00 mm (3.149-3.150 in.)
Maximum T.I.R.	0.05 mm (0.002 in.)
End Play	0.09—0.22 mm (0.004—0.009 in.)
Cylinder Bore	
Standard Cylinder Bore I.D.	88.98—89.00 mm (3.503—3.504 in.)
Maximum Cylinder Bore I.D.	89.08 mm (3.507 in.)
Piston-to-Cylinder Bore Clearance	0.13—0.17 mm (0.005—0.0067 in.)

Continued on next page

MX,1015CL,3 -19-23OCT95

Group 20—Cylinder Block and Internal Components—Continued

Item	Specification
Rebore Cylinder	
Oversize Diameter	
0.50 mm	89.48—89.50 mm (3.523—3.524 in.)
Oil Pump	
Minimum Rotor Shaft O.D.	
Large O.D.	12.63 mm (0.497 in.)
Small O.D.	7.94 mm (0.313 in.)
Maximum Rotor Shaft Bearing I.D.	
Oil Pump Cover	12.76 mm (0.502 in.)
Crankcase Cover	8.07 mm (0.318 in.)
Outer Rotor	
Minimum Thickness	11.92 mm (0.470 in.)
Minimum O.D.	28.95 mm (1.140 in.)
Outer Rotor Bearing	
Maximum Depth	12.14 mm (0.478 in.)
Maximum I.D.	29.20 mm (1.149 in.)
Minimum Valve Spring Free Length	19.00 mm (0.750 in.)
Governor	
Shaft Height	32.2-32.8 mm (1.267-1.291 in.)
Lever Nut Torque	7 N·m (62 lb-in.)

MX,1015CL,3A -19-04MAY92

10
15
5

SECTION 20—ENGINE REPAIR—PA540A

Group 10—Blower Housing and Flywheel

Item	Specification
Flywheel Nut Torque	172 N·m (127 lb-ft)
Minimum Flywheel Screen Gap	1.50 mm (0.059 in.)

Group 15—Cylinder Head and Valves

Item	Specification
Valve Clearance	0.15 mm (0.006 in.)
Breather Air Gap	1—2 mm (0.040—0.080 in.)
Rocker Arm	
Minimum Shaft O.D.	12.94 mm (0.509 in.)
Maximum Bearing I.D.	13.07 mm (0.515 in.)
Push Rod	
Maximum Bend	0.30 mm (0.012 in.)
Valves and Springs	
Minimum Spring Free Length	
PA540A-AS00	37.50 mm (1.476 in.)
PA540A-BS00, AS01 and AS02	35.50 mm (1.398 in.)
Minimum Valve Stem O.D.	
Intake Valve	6.930 mm (0.2728 in.)
Exhaust Valve	6.915 mm (0.2722 in.)
Valve Stem O.D.-New Parts	
Intake Valve	6.972-6.987 mm (0.2745-0.2751 in.)
Exhaust Valve	6.965-6.980 mm (0.2742-0.2748 in.)
Valve Stem to Guide Clearance-New Parts	
Intake Valve	0.013-0.043 mm (0.0005-0.0017 in.)
Exhaust Valve	0.020-0.050 mm (0.0008-0.0020 in.)
Maximum Valve Guide I.D.	7.07 mm (0.278 in.)
Valve Guide I.D.-New Parts	7.000-7.015 mm (0.2756-0.2762 in.)
Valve Stem to Guide Clearance-New Parts	
Intake Valve	0.013-0.043 mm (0.0005-0.0017 in.)
Exhaust Valve	0.020-0.050 mm (0.0008-0.0020 in.)
Valve Guide Bushing Height	
PA540A-BS00, AS01 and AS02	9.5 mm (0.372 in.)
Valve Guide Bushing Finished I.D.	7.0-7.02 mm (0.275-0.276 in.)
Maximum Valve Stem Bend	0.03 mm (0.001 in.)

Continued on next page

MX,1015CL,4 -19-23OCT95

Group 15—Cylinder Head and Valves—Continued

Item	Specification
Valve Seating Surface	1.10—1.46 mm (0.043—0.057 in.)
Valve Seat and Face Angle	45°
Minimum Valve Margin	0.60 mm (0.020 in.)
Valve Narrowing Angle	30°
Cylinder Head	
Cylinder Head Flatness	0.05 mm (0.002 in.)
Studs Torque	36 N·m (27 lb-ft)
Cap Screw Torque In Sequence (Lubricated)	
Initial Torque	32 N·m (24 lb-ft)
Final Torque	52 N·m (38 lb-ft)
Spark Plug Torque	20 N·m (177 lb-in.)

Group 20—Cylinder Block and Internal Components

Item	Specification
Crankcase Cover	
Oil Capacity	
Without Filter	2.6 L (2.7 qt)
With Filter	2.8 L (2.9 qt)
Total System	3.9 L (4.1 qt)
Cap Screw Torque PA540A-BS00, AS00 and AS01	23 N·m (204 lb-in.)
Cap Screw Torque PA540A-AS02	27 N·m (239 lb-in.)
Hydrostatic Pump Cover Torque	25 N·m (226 lb-in.)
Oil Drain Plug	24 N·m (217 lb-in.)
Magnet Cap Screw Torque	6 N·m (53 lb-in.)
Camshaft	
Minimum End Journal O.D.	
PTO Side	20.91 mm (0.823 in.)
Flywheel Side	20.91 mm (0.823 in.)
Minimum Lobe Height	37.10 mm (1.461 in.)
Maximum Bearing I.D.	
Crankcase	21.08 mm (0.830 in.)
Crankcase Cover	21.08 mm (0.830 in.)
Reciprocating Balancer	
Link Rod	
Minimum Journal O.D.	57.94 mm (2.281 in.)
Maximum Small End I.D.	12.06 mm (0.475 in.)
Maximum Large End I.D.	58.15 mm (2.289 in.)
Bushing Depth	1.00 mm (0.040 in.)
Balancer Weight	
Maximum Bearing I.D.	26.10 mm (1.027 in.)
Bushing Depth	0.50 mm (0.020 in.)

Continued on next page

MX,1015CL,5 -19-23OCT95

Group 20—Cylinder Block and Internal Components—Continued

Item	Specification
Support Shaft	
Minimum Shaft O.D.	25.93 mm (1.021 in.)
Nuts Torque	7.3 N·m (65 lb-in.)
Piston	
Maximum Ring Groove Clearance	
Top Ring	0.17 mm (0.007 in.)
Second Ring	0.15 mm (0.006 in.)
Oil Ring	0.20 mm (0.008 in.)
Minimum Ring End Gap	0.18 mm (0.007 in.)
Maximum Ring End Gap	
Compression Rings	0.90 mm (0.035 in.)
Oil Ring Side Rails	1.30 mm (0.051 in.)
Minimum Pin O.D.	21.98 mm (0.865 in.)
Maximum Pin Bore I.D.	22.04 mm (0.868 in.)
Maximum Piston-to-Piston Pin Clearance	0.06 mm (0.002 in.)
Piston O.D.	88.83—88.86 mm (3.4885—3.498 in.)
Piston-to-Cylinder Bore Clearance	0.11—0.15 mm (0.0043—0.0059 in.)
Connecting Rod	
Maximum Crankshaft Bearing I.D.	41.07 mm (1.617 in.)
Maximum Piston Pin Bearing I.D.	22.06 mm (0.868 in.)
Maximum Connecting Rod-to-Piston Pin Clearance	0.08 mm (0.003 in.)
Maximum Connecting Rod-to-Crankpin Clearance	0.14 mm (0.006 in.)
End-Cap Screw Torque	20 N·m (177 lb-in.)
Crankshaft	
Minimum PTO Side Journal O.D.	37.90 mm (1.492 in.)
Minimum Flywheel Side Journal O.D.	34.95 mm (1.376 in.)
Minimum Connecting Rod Journal O.D.	40.93 mm (1.611 in.)
Maximum Crankcase Cover Plain Bearing I.D.	38.06 mm (1.498 in.)
Ball Bearing O.D.-New Part	79.98-80.00 mm (3.149-3.150 in.)
Maximum T.I.R.	0.05 mm (0.002 in.)
End Play	0.09—0.22 mm (0.004—0.009 in.)
Oil Seal Depth	0.50 mm (0.020 in.)
Cylinder Bore	
Standard Cylinder Bore I.D.	88.98—89.00 mm (3.503—3.504 in.)
Maximum Cylinder Bore I.D.	89.08 mm (3.507 in.)
Piston-to-Cylinder Bore Clearance	0.11—0.15 mm (0.0043—0.0059 in.)

Continued on next page

MX,1015CL,6 -19-23OCT95

Group 20—Cylinder Block and Internal Components—Continued

Item	Specification
Rebore Cylinder	
Oversize Diameter	
0.50 mm (0.020 in.)	89.46—89.48 mm (3.522—3.523 in.)
Oil Pump	
Minimum Rotor Shaft O.D.	12.63 mm (0.497 in.)
Maximum Rotor Shaft Bearing I.D.	12.76 mm (0.502 in.)
Outer Rotor	
Minimum Thickness	9.92 mm (0.391 in.)
Minimum O.D.	40.47 mm (1.596 in.)
Outer Rotor Bearing	
Maximum Depth	10.17 mm (0.401 in.)
Maximum I.D.	40.77 mm (1.605 in.)
Minimum Valve Spring Free Length	19.00 mm (0.750 in.)
Governor	
Shaft Height	32.2-32.8 mm (1.267-1.291 in.)
Lever Nut Torque	7 N·m (62 lb-in.)

MX,1015CL,6A -19-23OCT95

SECTION 30—FUEL AND AIR REPAIR

Item	Specification
Breather	
Air Gap	1—2 mm (0.040—0.080 in.)

MX,1015CL,6B -19-23OCT95

SECTION 40—ELECTRICAL

Item	Specification
PTO Clutch Clearance	0.46 mm (0.018 in.)
PTO Mounting Cap Screw Torque	
Ogura	56 N·m (45 lb-ft)
Warner	75 N·m (55 lb-ft)
Starter Brush Length (Minimum)	
PA420A	6 mm (0.240 in.)
PA540A	10.5 mm (0.413 in.)
Ignition Coil Air Gap	0.30 mm (0.012 in.)

MX,1015CL,7 -19-23OCT95

SECTION 50—POWER TRAIN

Item	Specification
Variable Displacement Pump	
Outer Rotor O.D. (Minimum)	40.45 mm (1.593 in.)
Outer Rotor Thickness (Minimum)	12.95 mm (0.510 in.)
Pump Housing I.D. (Maximum)	40.80 mm (1.606 in.)
Pump Housing Depth (Maximum)	13.15 mm (0.518 in.)
Pump Cover Torque	
Initial	18. N·m (159 lb-in.)
Final	25.5 N·m (225 lb-in.)
Short Cap Screw Torque-PA420A/PA540A-AS01 and AS02	20 N·m (177 lb-in.)
Oil Line, Joint Fitting	100 N·m (74 lb-ft)
Oil Line, Joint Nut	79 N·m (58 lb-ft)
Relief Valve Spring Free Length (Minimum)	32 mm (1.26 in.)
Check Valve Spring Free Length (Minimum)	14 mm (0.55 in.)
Relief Valve Screw Torque	24.5 N·m (217 lb-in.)
Check Valve Plug	20 N·m (177 lb-in.)
Check Valve Screw	20 N·m (177 lb-in.)
Swashplate Bearing Cap Screw Torque-PA420A/PA540A-AS01 and AS02	1.6 N·m (12 lb-in.)
Fixed Displacement Pump Cylinder	
Piston O.D. (Minimum)	19.98 mm (0.787 in.)
Piston Ring-to-Groove Clearance (Maximum)	0.60 mm (0.024 in.)
Piston Spring Free Length (Minimum)	27 mm (1.063 in.)
Cylinder Bore I.D. (Maximum)	20.05 mm (0.789 in.)
Cylinder Spring Free Length (Minimum)	34.5 mm (1.36 in.)
Cylinder Spring Free Length (NEW)	
PA420A/PA540A-AS00 and BS00	45.6 mm (1.80 in.)
PA420A/PA540A-AS01 and AS02	44.7 mm (1.76 in.)
Shaft Journal O.D. (Minimum)	11.90 mm (0.46 in.)
Control Shaft Cap Screws	24.5 N·m (217 lb-in.)
Axle Assemblies	
Axle Housing Seal Depth	2 mm (0.079 in.)
Transmission Axle	
Run-out (Maximum)	1.6 mm (0.06 in.)
Oil Seal Journal O.D. (Minimum)	25 mm (0.984 in.)
Needle Bearing Journal O.D. (Minimum)	24.9 mm (0.982 in.)
Differential Axle	
Run-out (Maximum)	0.6 mm (0.024 in.)
Axle Housing Cap Screw	
Initial Torque	30 N·m (22 lb-ft)
Final Torque	42 N·m (31 lb-ft)
Isolator Mount Cap Screw Torque	25.5 N·m (255 lb-in.)

MX,1015CL,7A -19-23OCT95

SECTION 50—POWER TRAIN

Item	Specification
Transmission	
Input Shaft	
Large Journal (Minimum)	39.97 mm (1.573 in.)
Small Journal (Minimum)	31.94 mm (1.258 in.)
Fixed Displacement Motor Cylinder	
Piston O.D. (Minimum)	19.98 mm (0.787 in.)
Piston Ring-to-Groove Clearance (Maximum)	0.60 mm (0.024 in.)
Piston Spring Free Length (Minimum)	27 mm (1.063 in.)
Cylinder Bore I.D. (Maximum)	20.05 mm (0.789 in.)
Retaining Spring Free Length (Minimum)-PA420A/PA540A-AS00 and BS00	42 mm (1.65 in.)
Motor Housing Plug Torque	17.5 N·m (155 lb-in.)
Pipe Joint Torque	100 N·m (74 lb-ft)
Free-Wheeling Valve	
Push Rod Movement	8 mm (0.31 in.)
Sleeve Torque	41 N·m (30 lb-ft)
Sleeve Bolt Torque	31 N·m (23 lb-ft)
Differential	
Shaft O.D. (Minimum)	13.70 mm (0.539 in.)
Bevel Gear Journal O.D. (Minimum)	29.91 mm (1.178 in.)
Pinion Gear I.D. (Maximum)	14.35 mm (0.565 in.)
Case, Bevel Gear Bore I.D. (Maximum)	30.08 mm (1.184 in.)
Case, Ball Bearing Journal O.D. (Minimum)	55.93 mm (2.202 in.)
Case, Cap Screw Torque	25.5 N·m (225 lb-in.)

MX,1015CL,7B -19-23OCT95

SECTION 60—STEERING

Item	Specification
Draglink Rod Ball Joint Nut Torque	34 N·m (25 lb-ft)
Steering Arm Ball Joint Nut Torque	37 N·m (27 lb-ft)
Front Wheel Cap Screw Torque	50 N·m (37 lb-ft)

MX,1015CL,8 -19-23OCT95

SECTION 80—MISCELLANEOUS

Item	Specification
38-Inch Mower Deck	
Spindle Mounting Nut Torque	25 N·m (221 lb-in.)
Blade Cap Screw Torque	75 N·m (55 lb-ft)
Spindle Sheave Nut	140 N·m (103 lb-ft)
46-Inch Mower Deck	
Spindle Mounting Nut Torque	25 N·m (221 lb-in.)
Blade Cap Screw Torque	75 N·m (55 lb-ft)
Spindle Rolling Drag Torque (Maximum)	0.07 N·m (0.6 lb-in.)
48-Inch Mower Deck	
Spindle Mounting Nut Torque	26 N·m (19 lb-ft)
Blade Cap Screw Torque	68 N·m (50 lb-ft)
Spindle Sheave Nut	163 N·m (120 lb-ft)
Lower Seal Depth	7.8 mm (0.31 in.)
Jack Sheave Nut Torque	136 N·m (100 lb-ft)
Tensioning Idle Sheave Nut Torque	27 N·m (20 lb-ft)

MX,1015CL,8A -19-23OCT95

TUNE-UP SPECIFICATIONS

	F510, PA420A ENGINE	F525, PA540A ENGINE
Spark Plug Type	Champion RN11YC, NGK-BPR5ES, John Deere M802138	Champion RN11YC, NGK-BPR5ES, John Deere M802138
Spark Plug Gap	0.75 mm (0.030 in.)	0.75 mm (0.030 in.)
Spark Plug Torque	20 N·m (177 lb-in.)	20 N·m (177 lb-in.)
Slow Idle Speed	1450 RPM	1450 RPM
Fast Idle Speed	3250 ±50 RPM	3250 ±50 RPM

MX,1015CL,9 -19-23OCT95

TUNE-UP ADJUSTMENTS

1. Clean engine cooling fins.
2. Clean or replace air filter.
3. Replace fuel filter.
4. Check electrolyte level.
5. Clean, regap or replace spark plug.
6. Check charging system output.
7. Check engine compression.
8. Adjust carburetor and throttle linkage.
9. Adjust governor.
10. Check and clean crankcase breather.
11. Check crankcase vacuum.
12. Adjust brake.
13. Check transaxle and steering linkage.
14. Check tire pressure.

MX,1015CL,10 -19-23OCT95

10
15
13

METRIC BOLT AND CAP SCREW TORQUE VALUES

10
15
14

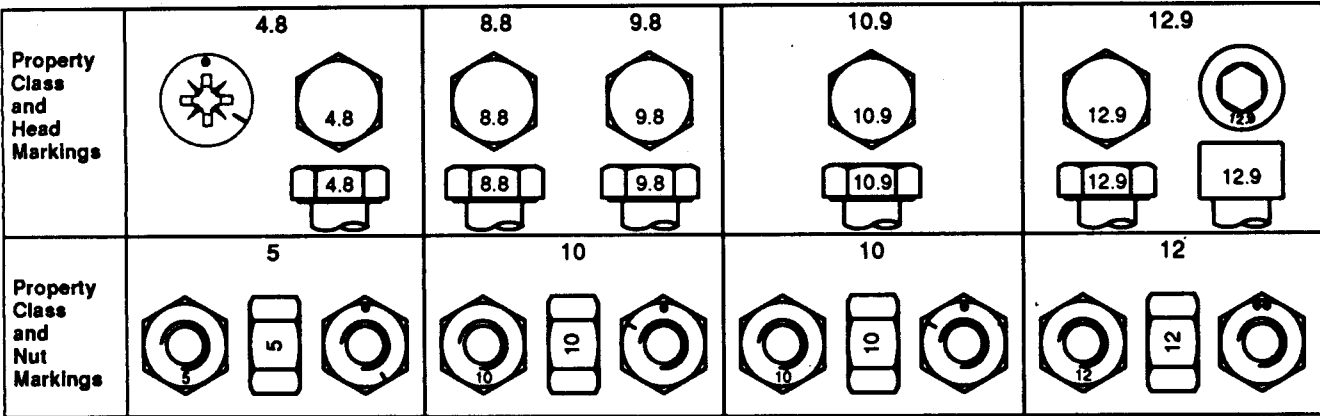

TS1163 -19-04/MAR91

Size	Class 4.8				Class 8.8 or 9.8				Class 10.9				Class 12.9			
	Lubricated ^a		Dry ^a		Lubricated ^a		Dry ^a		Lubricated ^a		Dry ^a		Lubricated ^a		Dry ^a	
	N-m	lb-ft	N-m	lb-ft	N-m	lb-ft	N-m	lb-ft	N-m	lb-ft	N-m	lb-ft	N-m	lb-ft	N-m	lb-ft
M6	4.8	3.5	6	4.5	9	6.5	11	8.5	13	9.5	17	12	15	11.5	19	14.5
M8	12	8.5	15	11	22	16	28	20	32	24	40	30	37	28	47	35
M10	23	17	29	21	43	32	55	40	63	47	80	60	75	55	95	70
M12	40	29	50	37	75	55	95	70	110	80	140	105	130	95	165	120
M14	63	47	80	60	120	88	150	110	175	130	225	165	205	150	260	190
M16	100	73	125	92	190	140	240	175	275	200	350	255	320	240	400	300
M18	135	100	175	125	260	195	330	250	375	275	475	350	440	325	560	410
M20	190	140	240	180	375	275	475	350	530	400	675	500	625	460	800	580
M22	260	190	330	250	510	375	650	475	725	540	925	675	850	625	1075	800
M24	330	250	425	310	650	475	825	600	925	675	1150	850	1075	800	1350	1000
M27	490	360	625	450	950	700	1200	875	1350	1000	1700	1250	1600	1150	2000	1500
M30	675	490	850	625	1300	950	1650	1200	1850	1350	2300	1700	2150	1600	2700	2000
M33	900	675	1150	850	1750	1300	2200	1650	2500	1850	3150	2350	2900	2150	3700	2750
M36	1150	850	1450	1075	2250	1650	2850	2100	3200	2350	4050	3000	3750	2750	4750	3500

DO NOT use these values if a different torque value or tightening procedure is given for a specific application. Torque values listed are for general use only. Check tightness of fasteners periodically.

Make sure fasteners threads are clean and that you properly start thread engagement. This will prevent them from failing when tightening.









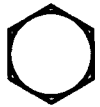

Shear bolts are designed to fail under predetermined loads. Always replace shear bolts with identical property class.

Tighten plastic insert or crimped steel-type lock nuts to approximately 50 percent of the dry torque shown in the chart, applied to the nut, not to the bolt head. Tighten toothed or serrated-type lock nuts to the full torque value.

Fasteners should be replaced with the same or higher property class. If higher property class fasteners are used, these should only be tightened to the strength of the original.

^a "Lubricated" means coated with a lubricant such as engine oil, or fasteners with phosphate and oil coatings. "Dry" means plain or zinc plated without any lubrication.

UNIFIED INCH BOLT AND CAP SCREW TORQUE VALUES

SAE Grade and Head Markings	1 or 2 ^b	5	5.1	5.2	8	8.2
	NO MARK 					
SAE Grade and Nut Markings	2	5		8		
	NO MARK 					

Size	Grade 1				Grade 2 ^b				Grade 5, 5.1, or 5.2				Grade 8 or 8.2			
	Lubricated ^a		Dry ^a		Lubricated ^a		Dry ^a		Lubricated ^a		Dry ^a		Lubricated ^a		Dry ^a	
	N-m	lb-ft	N-m	lb-ft	N-m	lb-ft	N-m	lb-ft	N-m	lb-ft	N-m	lb-ft	N-m	lb-ft	N-m	lb-ft
1/4	3.7	2.8	4.7	3.5	6	4.5	7.5	5.5	9.5	7	12	9	13.5	10	17	12.5
5/16	7.7	5.5	10	7	12	9	15	11	20	15	25	18	28	21	35	26
3/8	14	10	17	13	22	16	27	20	35	26	44	33	50	36	63	46
7/16	22	16	28	20	35	26	44	32	55	41	70	52	80	58	100	75
1/2	33	25	42	31	53	39	67	50	85	63	110	80	120	90	150	115
9/16	48	36	60	45	75	56	95	70	125	90	155	115	175	130	225	160
5/8	67	50	85	62	105	78	135	100	170	125	215	160	240	175	300	225
3/4	120	87	150	110	190	140	240	175	300	225	375	280	425	310	550	400
7/8	190	140	240	175	190	140	240	175	490	360	625	450	700	500	875	650
1	290	210	360	270	290	210	360	270	725	540	925	675	1050	750	1300	975
1-1/8	400	300	510	375	400	300	510	375	900	675	1150	850	1450	1075	1850	1350
1-1/4	570	425	725	530	570	425	725	530	1300	950	1650	1200	2050	1500	2600	1950
1-3/8	750	550	950	700	750	550	950	700	1700	1250	2150	1550	2700	2000	3400	2550
1-1/2	1000	725	1250	925	990	725	1250	930	2250	1650	2850	2100	3600	2650	4550	3350

DO NOT use these values if a different torque value or tightening procedure is given for a specific application. Torque values listed are for general use only. Check tightness of fasteners periodically.

Shear bolts are designed to fail under predetermined loads. Always replace shear bolts with identical grade.

^a "Lubricated" means coated with a lubricant such as engine oil, or fasteners with phosphate and oil coatings. "Dry" means plain or zinc plated without any lubrication.

^b Grade 2 applies for hex cap screws (not hex bolts) up to 152 mm (6-in.) long. Grade 1 applies for hex cap screws over 152 mm (6-in.) long, and for all other types of bolts and screws of any length.

Fasteners should be replaced with the same or higher grade. If higher grade fasteners are used, these should only be tightened to the strength of the original.

Make sure fasteners threads are clean and that you properly start thread engagement. This will prevent them from failing when tightening.

Tighten plastic insert or crimped steel-type lock nuts to approximately 50 percent of the dry torque shown in the chart, applied to the nut, not to the bolt head. Tighten toothed or serrated-type lock nuts to the full torque value.

10510
-19-04MAR91
TS1162

GASOLINE



TS227 -UN-23AUG88

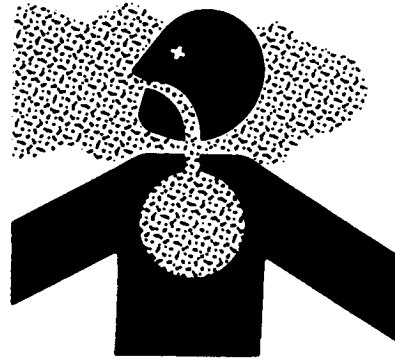

TS220 -UN-23AUG88

 **CAUTION: Gasoline is HIGHLY FLAMMABLE, handle it with care.**

DO NOT refuel machine while:

- indoors, always fill gas tank outdoors;
- machine is near an open flame or sparks;
- engine is running, **STOP** engine;
- engine is hot, allow it to cool sufficiently first;
- smoking.

Help prevent fires:

- fill gas tank to bottom of filler neck only;
- be sure fill cap is tight after fueling;
- clean up any gas spills **IMMEDIATELY**;
- keep machine clean and in good repair—free of excess grease, oil, debris, and faulty or damaged parts;
- any storage of machines with gas left in tank should be in an area that is well ventilated to prevent possible igniting of fumes by an open flame or spark, this includes any appliance with a pilot light.

To prevent fire or explosion caused by **STATIC ELECTRIC DISCHARGE** during fueling:

- **ONLY** use a clean, approved **POLYETHYLENE PLASTIC** fuel container and funnel **WITHOUT** any metal screen or filter.

To avoid engine damage:

- **DO NOT** mix oil with gasoline;
- **ONLY** use fresh, clean gasoline;
- fill gas tank at the end of each day's operation to help prevent condensation from forming inside a partially filled tank;
- keep up with specified service intervals.

GASOLINE SPECIFICATIONS:

Unleaded gasoline with a minimum octane rating (anti-knock index) of 87 is recommended because it burns cleaner and leaves less unburned deposits in the engine combustion chamber.

Use of alternative oxygenated, gasohol blended, unleaded gasoline is acceptable as long as:

- the ethyl or grain alcohol blends **DO NOT** exceed 10% by volume or
- methyl tertiary butyl ether (MTBE) blends **DO NOT** exceed 15% by volume.

IMPORTANT: DO NOT use **METHANOL** gasolines because **METHANOL** is harmful to the environment and to your health.

GASOLINE STORAGE

10
20
2

IMPORTANT: Keep all dirt, scale, water or other foreign material out of gasoline.

Keep gasoline in a safe, protected area and in a clean, properly marked "UNLEADED GASOLINE" container. DO NOT use de-icers to attempt to remove water from gasoline. DO NOT depend on fuel filters to remove water from gasoline. It is recommended that a water separator be installed in the storage tank outlet.

BE SURE to properly discard unstable or contaminated gasoline.

Whether the unit is either stored or used during the winter, it is recommended that you add John Deere Gasoline Conditioner and Stabilizer (TY15977) or an equivalent to the gasoline. BE SURE to follow directions on container and properly discard empty container.

It is recommended that gasoline be stored ONLY in an approved POLYETHYLENE PLASTIC container WITHOUT any metal screen or filter. This will help prevent any accidental sparks from occurring.

MX,1020CL,2 -19-23OCT95

4-CYCLE GASOLINE ENGINE AND HYDROSTATIC TRANSMISSION OIL—NORTH AMERICA

NOTE: The F510 and F525 Residential Front Mowers are unique machines in that the engine and hydrostatic transmission are a unitized concept that share the same oil reservoir.

Use appropriate oil viscosity based on the expected air temperature range during the period between recommended oil changes.

The following John Deere oil is **PREFERRED**:

- **TORQ—GARD® SUPREME—SAE 5W-30.**

Other oils may be used if above John Deere oil is not available, provided they meet one of the following specifications:

- **SAE 5W-30—API Service Classifications SH and SG.**

IMPORTANT: Arctic oils (such as SAE 0W-30 or Military Specification MIL-L-46167B) may be used if temperatures fall below -30°C (-22°), but reduce the service interval by 50%. For prolonged operation under heavy load in temperatures above 40° (104°) reduce service interval by 50%.

John Deere Dealers: You may want to cross-reference the following publications to recommend the proper oil for your customers:

- Module DX,ENOIL2 in JDS-G135;
- Section 530, Lubricants & Hydraulics, of the John Deere Merchandise Sales Guide;
- Lubrication Sales Manual PI7032;
- Lawn & Grounds Care Tune-Up Guide PI672.

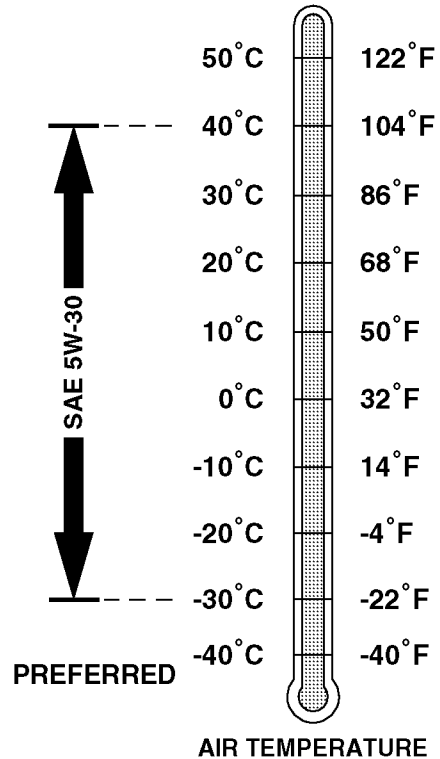

4-CYCLE GASOLINE ENGINE AND HYDROSTATIC TRANSMISSION OIL—EUROPE

NOTE: The F510 and F525 Residential Front Mowers are unique machines in that the engine and hydrostatic transmission are a unitized concept that share the same oil reservoir.

Use appropriate oil viscosity based on the expected air temperature range during the period between recommended oil changes.

The following John Deere oils are **PREFERRED**:

- **TORQ-GARD® SUPREME—SAE 5W-30;**
- **UNI-GARD™—SAE 5W-30.**

Other oils may be used if above John Deere oils are not available, provided they meet one of the following specifications:

- **CCMC Specification G5 and G4.**

IMPORTANT: Arctic oils (such as SAE 0W-30 or Military Specification MIL—L—46167B) may be used if temperatures fall below -30°C (-22°F), but reduce the service interval by 50%. For prolonged operation under heavy load in temperatures above 40°C (104°F) reduce service interval by 50%.

John Deere Dealers: You may want to cross-reference the following publications to recommend the proper oil for your customers:

- Module DX,ENOIL2 in JDS—G135;
- Section 530, Lubricants & Hydraulics, of the John Deere Merchandise Sales Guide.

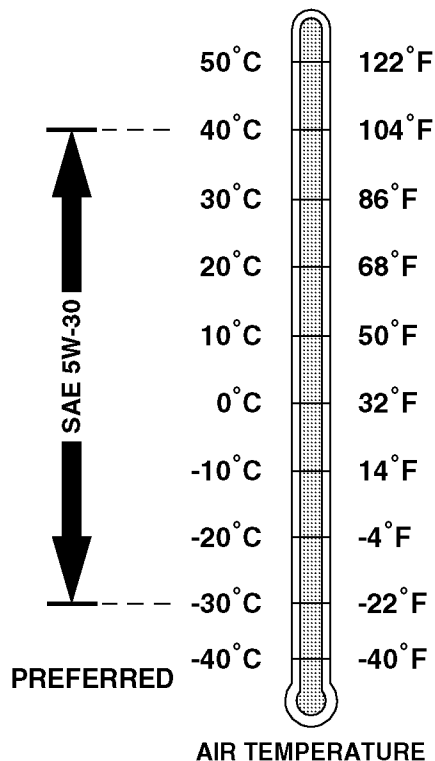

M83052 -19-18OCT95

MX,1020CL,4 -19-23OCT95

BREAK-IN OIL—NORTH AMERICA

IMPORTANT: ONLY use this specified break-in oil in rebuilt or remanufactured engines for the first 5 hours maximum. DO NOT use oils with heavier viscosity weights than SAE 5W-30 or oils meeting specifications API SG or SH, these oils will not allow rebuilt or remanufactured engines to break-in properly.

The following John Deere oil is **PREFERRED**:

- **BREAK-IN ENGINE OIL.**

John Deere BREAK-IN ENGINE OIL is formulated with special additives for aluminum and cast iron type engines to allow the power cylinder components (pistons, rings, and liners as well) to “wear-in” while protecting other engine components, valve train and gears, from abnormal wear.

Engine rebuild instructions should be followed closely to determine if special requirements are necessary.

John Deere BREAK-IN ENGINE OIL is also recommended for non-John Deere engines, both aluminum and cast iron types.

If this preferred John Deere Oil is not available, use a break-in engine oil meeting one of the following specifications during the first 5 hours of operation:

- **API Service Classification SE.**

After the break-in period, use the **PREFERRED** John Deere oil as recommended for the appropriate type engine.

John Deere Dealers: You may want to cross-reference the following publications to recommend the proper oil for your customers:

- Module DX, ENOIL4 in JDS-G135;
- Section 530, Lubricants & Hydraulics, of the John Deere Merchandise Sales Guide;
- Lubrication Sales Manual PI7032.

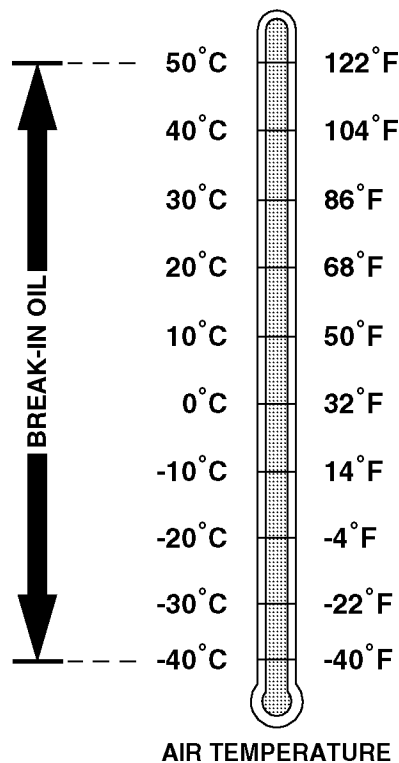

10
20
5
M83053 -19-18OCT95

BREAK-IN OIL—EUROPE

IMPORTANT: ONLY use this specified break-in oil in rebuilt or remanufactured engines for the first 5 hours maximum. DO NOT use oils with viscosity weights than SAE 5W-30 or oils meeting CCMC specifications G5—these oils will not allow rebuilt or remanufactured engines to break-in properly.

The following John Deere oil is **PREFERRED**:

- **BREAK-IN ENGINE OIL.**

John Deere BREAK-IN ENGINE OIL is formulated with special additives for aluminum and cast iron type engines to allow the power cylinder components (pistons, rings, and liners as well) to “wear-in” while protecting other engine components, valve train and gears, from abnormal wear.

Engine rebuild instructions should be followed closely to determine if special requirements are necessary.

John Deere BREAK-IN ENGINE OIL is also recommended for non-John Deere engines, both aluminum and cast iron types.

If above preferred John Deere break-in engine oil is not available, use a break-in engine oil meeting one of the following specifications during the first 5 hours of operation:

- **CCMC Specification G4.**

After the break-in period, use the **PREFERRED** John Deere oil as recommended for the appropriate type engine.

John Deere Dealers: You may want to cross-reference the following publications to recommend the proper oil for your customers:

- Module DX, ENOIL4 in JDS-G135;
- Section 530, Lubricants & Hydraulics, of the John Deere Merchandise Sales Guide.

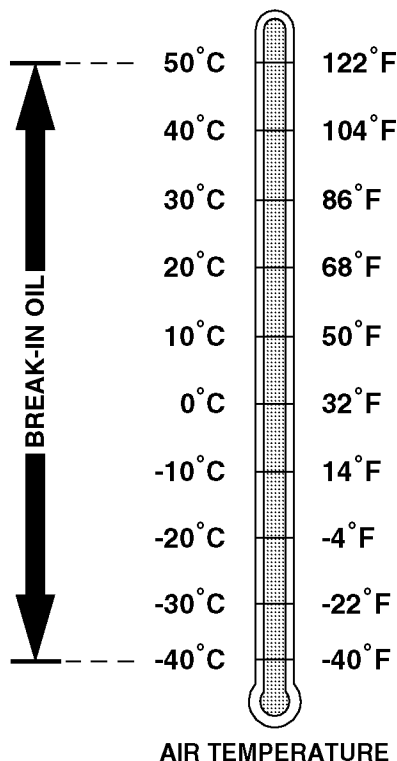

M83053 -19-18OCT95

GREASE—NORTH AMERICA

IMPORTANT: ONLY use the specified greases in this application. DO NOT mix any other greases in this application. DO NOT use any BIO-GREASE in this application.

The following John Deere greases are **PREFERRED**:

- **MOLY HIGH-TEMPERATURE EP GREASE—NLGI Grade 2, JDM J25C.**

The following John Deere grease is also recommended if the above preferred grease is not available:

- **HIGH-TEMPERATURE EP GREASE—NLGI Grade 2 JDM J13E4.**

Other greases may be used if above preferred John Deere greases are not available, provided they meet one of the following specifications:

- **NLGI Grade 2, JDM J25C (preferred);**
- **NLGI Grade 2, JDM J13E4.**

IMPORTANT: If minimum temperature should fall below -30°C (-22°F), the transmission grease must be heated to at least five degrees above the lower limit before start-up or transmission may be damaged. For prolonged operation under heavy load in temperatures above 40°C (104°F) reduce service interval by 50%.

John Deere Dealers: You may want to cross-reference the following publications to recommend the proper grease for your customers:

- Module DX,GREA1 in JDS-G135;
- Section 530, Lubricants & Hydraulics, of the John Deere Merchandise Sales Guide;
- the Lubrication Sales Manual PI7032 (1-95);
- the Lawn & Grounds Care Tune-Up Guide PI672 (1-95).

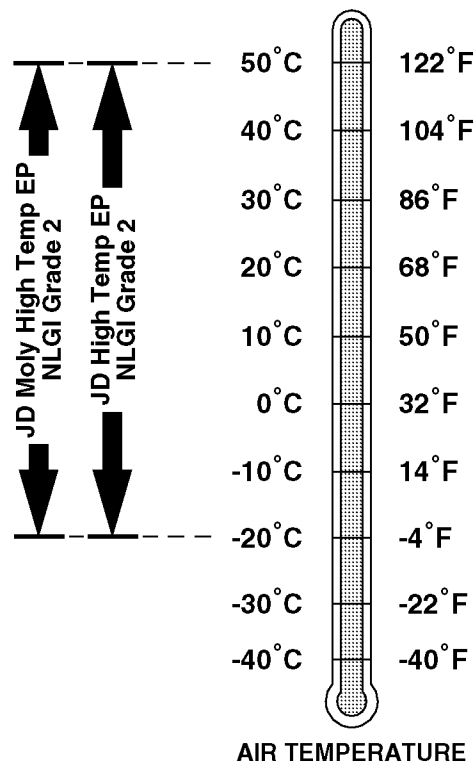

10
20
7

M83054 -19-18OCT95

GREASE—EUROPE

IMPORTANT: ONLY use a quality NLGI Grade 2 gear grease in this application. DO NOT mix any other greases in this application. DO NOT use any BIO-GREASE in this application.

The following John Deere gear grease is **PREFERRED**:

- **GREASE-GARD—JDM J25C.**

Other gear greases may be used if above recommended John Deere gear greases are not available, provided they meet the following specification:

- **NLGI Grade 2, JDM J25C.**

IMPORTANT: If minimum temperature should fall below -30°C (-22°F), the transmission grease must be heated to at least five degrees above the lower limit before start-up or transmission may be damaged. For prolonged operation under heavy load in temperatures above 50°C (122°F) reduce service interval by 50%.

John Deere Dealers: You may want to cross-reference the following publications to recommend the proper grease for your customers:

- Module DX,GREA1 in JDS-G135;
- Section 530, Lubricants & Hydraulics, of the John Deere Merchandise Sales Guide.

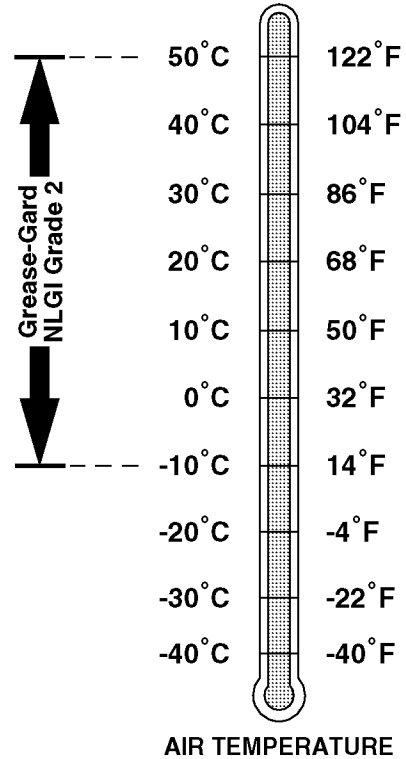

M83055 -19-18OCT95

ALTERNATIVE LUBRICANTS

Conditions in certain geographical areas outside the United States and Canada may require different lubricant recommendations than the ones printed in this technical manual or the operator's manual. Consult with your John Deere Dealer, or Sales Branch, to obtain the alternative lubricant recommendations.

IMPORTANT: Use of alternative lubricants could cause reduced life of the component. If alternative lubricants are to be used, it is recommended that the factory fill be thoroughly removed before switching to any alternative lubricant.

MX,1020CL,9 -19-23OCT95

SYNTHETIC LUBRICANTS

Synthetic lubricants may be used in John Deere equipment if they meet the applicable performance requirements (industry classification and/or military specification) as shown in this manual.

The recommended temperature limits and service or lubricant change intervals should be maintained as shown in the operator's manual, unless otherwise stated on lubricant label.

Avoid mixing different brands, grades, or types of oil. Oil manufacturers blend additives in their oils to meet certain specifications and performance requirements. Mixing different oils can interfere with the proper functioning of these additives and degrade lubricant performance.

MX,1020CL,10 -19-23OCT95

LUBRICANT STORAGE

All machines operate at top efficiency only when clean lubricants are used. Use clean storage containers to handle all lubricants. Store them in an area protected from dust, moisture, and other contamination. Store drums on their sides. Make sure all containers are properly marked as to their contents. Dispose of all old, used containers and their contents properly.

MX,1020CL,11 -19-23OCT95

MIXING OF LUBRICANTS

In general, avoid mixing different brands or types of lubricants. Manufacturers blend additives in their lubricants to meet certain specifications and performance requirements. Mixing different lubricants can interfere with the proper functioning of these additives and lubricant properties which will downgrade their intended specified performance.

MX,1020CL,12 -19-23OCT95

OIL FILTERS

IMPORTANT: Filtration of oils is critical to proper lubrication performance. Always change filters regularly.

The following John Deere oil filters are **PREFERRED**:

- **AUTOMOTIVE AND LIGHT TRUCK ENGINE OIL FILTERS.**

Most John Deere filters contain pressure relief and anti-drainback valves for better engine protection. Other oil filters may be used if above recommended John Deere oil filters are not available, provided they meet the following specification:

- **ASTB Tested In Accordance With SAE J806.**

John Deere Dealers: You may want to cross-reference the following publications to recommend the proper oil filter for your customers:

- Module DX,FILT in JDS-G135;
- Section 540, Lubricants & Hydraulics, of the John Deere Merchandise Sales Guide;
- Lawn & Grounds Care Tune-Up Guide PI672.

MX,1020CL,13 -19-23OCT95

SERIAL NUMBER INFORMATION

When working on machines or components that are covered by warranty, it is IMPORTANT that you include the machine's Product Identification Number and the Component Serial Number on the warranty claim form.

The location of Component Serial Number plates are shown below.

MX,1025CL,1 -19-23OCT95

RECORD PRODUCT IDENTIFICATION NUMBER

The mower's 13 digit product identification number is located on the left-hand rear corner of the frame.

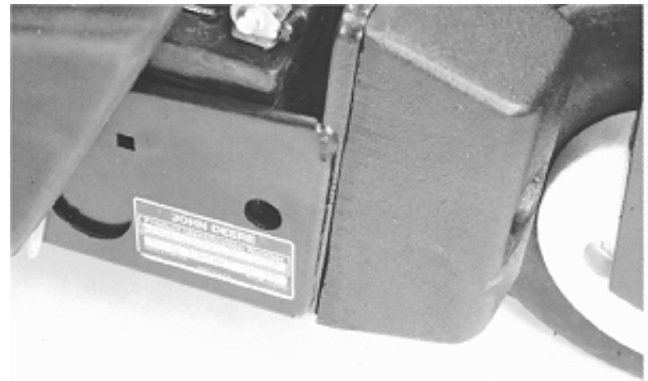

M61965
-UN-15MAR89

MX,1025CL,2 -19-04MAY92

RECORD ENGINE SERIAL NUMBER

The engine serial number (A) is located on the left side of the blower housing.



M62297
-UN-15MAR89

MX,1025CL,3 -19-04MAY92

Section 20 ENGINE REPAIR

Contents

	Page		Page
Group 05—Remove and Install Engine			
Remove Engine	20-05-1	Remove and Install Crankcase Cover . . .	20-20-3
Repair Isolators	20-05-3	Crankcase Cover Magnet	20-20-4
Install Engine	20-05-4	Camshaft	
		Remove and Install	20-20-4
		Inspect	20-20-5
		Inspect Bearings	20-20-6
		Inspect Automatic Compression Release .	20-20-7
		Remove/Inspect/Install Tappets	20-20-7
		Reciprocating Balancer	
		Remove and Install	20-20-8
		Disassemble and Assemble	20-20-9
		Inspect	20-20-10
		Replace Bushings	20-20-11
		Piston and Connecting Rod	
		Remove and Install	20-20-12
		Disassemble, Inspect and Assemble . . .	20-20-13
		Piston Rings	
		Remove and Install	20-20-13
		Check End Gap	20-20-14
		Inspect	
		Piston	20-20-14
		Analyze	
		Piston Ring Wear	20-20-16
		Piston Wear	20-20-18
		Connecting Rod	20-20-20
		Crankshaft and Connecting Rod Wear . . .	20-20-21
		Crankshaft	
		Remove, Inspect and Install	20-20-22
		Regrind	20-20-23
		Inspect Plain Bearing	20-20-24
		Inspect Ball Bearing	20-20-24
		Check Alignment (TIR)	20-20-25
		Measure End Play	20-20-25
		Adjust End Play	20-20-26
		Inspect	
		Oil Seals	20-20-27
		Cylinder Block	20-20-28
		Deglaze Cylinder Bore	20-20-29
		Rebore Cylinder Block	20-20-30
		Oil Pump—PA420A	
		Disassemble and Assemble	20-20-31
		Inspect	20-20-32
Group 10—Blower Housing and Flywheel			
Engine Configuration Chart	20-10-1		
Service Parts Kits	20-10-1		
Remove and Install Blower Housing	20-10-2		
Flywheel Screen Adjustment	20-10-2		
Remove and Install Flywheel	20-10-3		
Group 15—Cylinder Head and Valves			
Engine Configuration Chart	20-15-1		
Essential Tools	20-15-1		
Service Equipment and Tools	20-15-1		
Other Materials	20-15-2		
Service Parts Kits	20-15-2		
Rocker Arm Assembly—PA420A/PA540A			
Remove and Install	20-15-3		
Inspect	20-15-3		
Cylinder Head Assembly			
Remove and Install	20-15-4		
Valves and Springs			
Remove and Install	20-15-6		
Inspect and Replace Stem Seals	20-15-6		
Inspect			
Valve Springs	20-15-7		
Cylinder Head	20-15-7		
Replace Cylinder Head Studs	20-15-7		
Valves			
Inspect	20-15-8		
Analyze	20-15-9		
Valve Guides	20-15-11		
Replace Valve Guide Bushings	20-15-11		
Recondition Valve Seats	20-15-13		
Lap	20-15-14		
Check Valve Clearance	20-15-14		
Group 20—Cylinder Block and Internal Components			
Engine Configuration Chart	20-20-1		
Other Materials	20-20-1		
Service Parts Kits	20-20-2		

Continued on next page

Page

Oil Pump—PA540A
Disassemble and Assemble 20-20-34
Inspect 20-20-35
Remove, Inspect and Install Oil Filter
Manifold 20-20-38
Inspect and Replace
Governor 20-20-38
Governor Arm 20-20-39

20

REMOVE ENGINE

1. Disconnect battery cables. (Disconnect negative cable at engine first.)

2. Remove mower deck.

NOTE: Oil reservoir capacity is approximately 3.4 L (3.5 qt).

3. Remove drain plug (A) and drain oil reservoir.

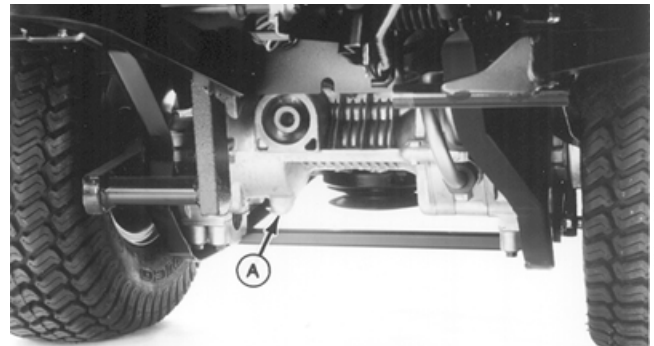

MX,2005CL,A1 -19-23OCT95

M81636 -JUN-23MAY95

20-05

4. Remove front wheels. (See Remove and Install Wheels in Section 60, Group 10.)

5. Remove snap ring (A). Remove mower deck arms.

6. Remove seat platform (B). (See Remove and Install Seat Platform in Section 80, Group 15.)

7. Remove fenders. (See Right Fender—Service Removal and Left Fender Replacement in Section 80, Group 15.)

8. Close fuel shut-off valve (C).

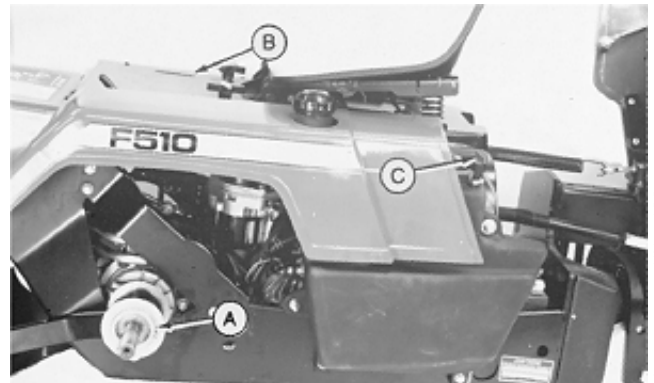

MX,2005CL,A1A -19-23OCT95

M53037 -JUN-13APR89

Remove and Install Engine/Remove Engine

9. Disconnect wires (C) and (D).
10. Disconnect harness (A).
11. Disconnect linkages (B) and (E).
12. Remove shield, cap screws (F) and muffler.
13. Remove braces (I).
14. Remove bracket (H).
15. Disconnect and drain fuel inlet line at fuel pump.
16. Remove cap screws (G).
17. Remove engine.

- A—Engine Harness
- B—Brake Linkage
- C—Purple Wire (Solenoid)
- D—Red Wires (Battery Cable and Pigtail)
- E—Shift Linkage
- F—Muffler Cap Screws
- G—Engine Mount Cap Screws (3)
- H—Fender Bracket
- I—Frame Braces (2)

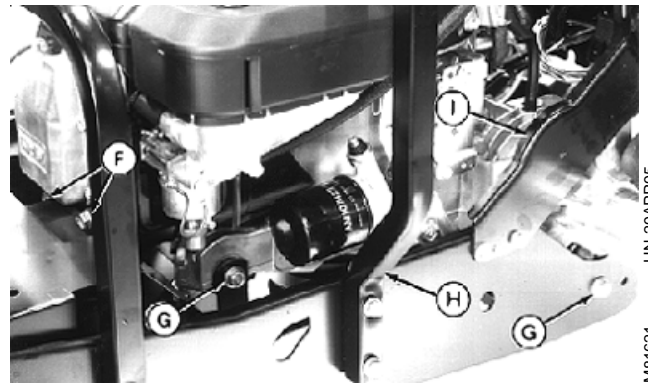
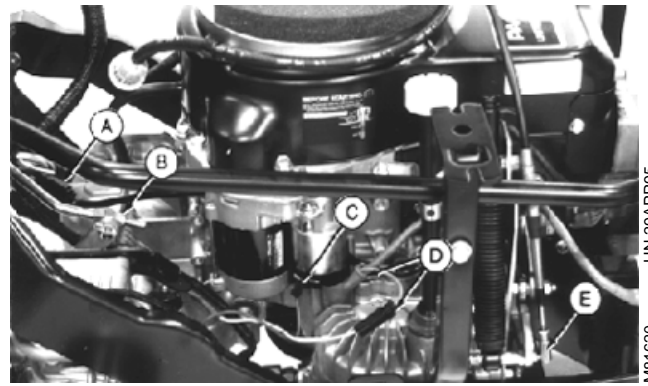

MX,2005CL,A2 -19-23OCT95

REPAIR ISOLATORS

1. Inspect isolators for wear, oil contamination, and damage. Replace isolators as needed.

IMPORTANT: Misalignment or oil applied to the isolators will reduce the dampening of the isolators. Be careful to install the isolators correctly.

2. Push PTO clutch isolator into crankcase cover until surface (A) is even with outer flange (B) of the seat.

3. Install the engine mount isolator with the letters "UP" (C) away from the mounting bracket (D). Also the molded rubber projection (E) must be centered between the marks (F), if equipped, or centered on the mounting bracket. Tighten mounting bracket cap screws.

4. Install the axle mount isolators with the letters "UP" (G) aligned with the axle housing rib (H). Push the isolator into the housing until seated against the housing shoulder (I). Tighten mounting bracket cap screws.

- A—PTO Clutch Isolator Surface
- B—Seat Outer Flange
- C—Letters "UP"
- D—Mounting Bracket
- E—Molded Rubber Projection
- F—Mounting Bracket Marks
- G—Letters "UP"
- H—Axle Housing Rib
- I—Housing Shoulder

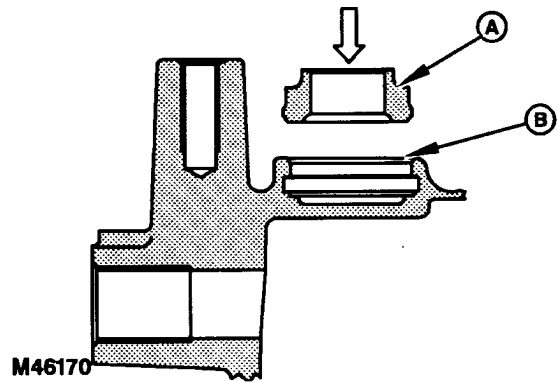

PTO Clutch Isolator

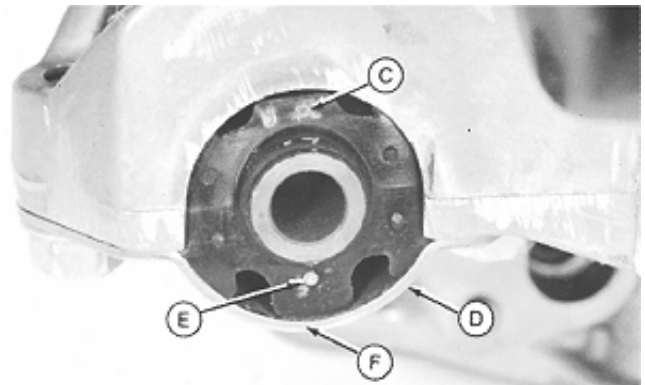

Engine Mount Isolator

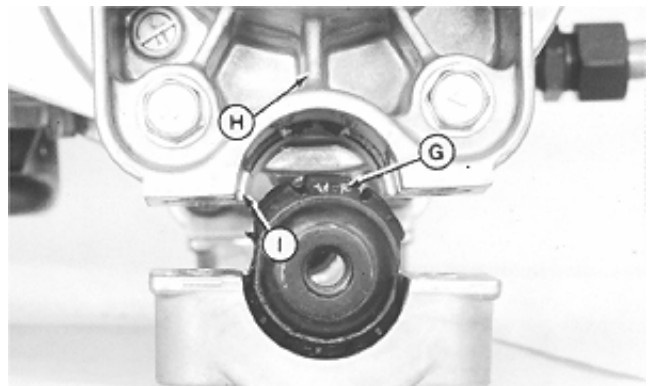

Axle Mount Isolator

MX,2005CL,5 -19-04MAY92

M46170 -UN-22APR92

M46170 -UN-22APR92

M46171

M46172 -UN-22APR92

M46172

33520

INSTALL ENGINE

1. Lower engine into frame. Connect cap screws (G).
2. Connect fuel line.
3. Install bracket (H).
4. Install braces (I).
5. Install muffler using cap screws (F). Install muffler shield.
6. Connect linkages (B) and (E).
7. Connect harness (A).
8. Connect wires (C) and (D).

A—Engine Harness
B—Brake Linkage
C—Purple Wire (Solenoid)
D—Red Wires (Battery Cable and Pigtail)
E—Shift Linkage
F—Muffler Cap Screws
G—Engine Mount Cap Screws (3)
H—Fender Bracket
I—Frame Braces (2)

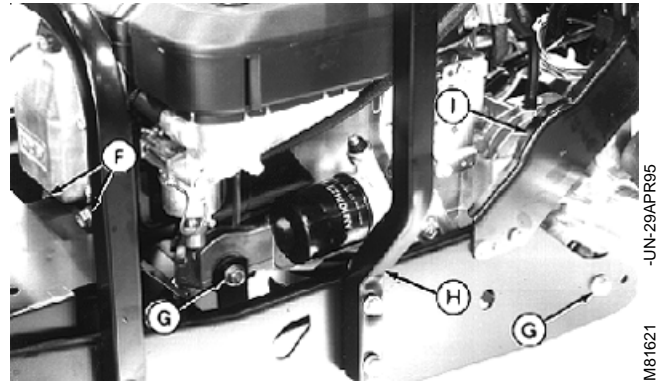
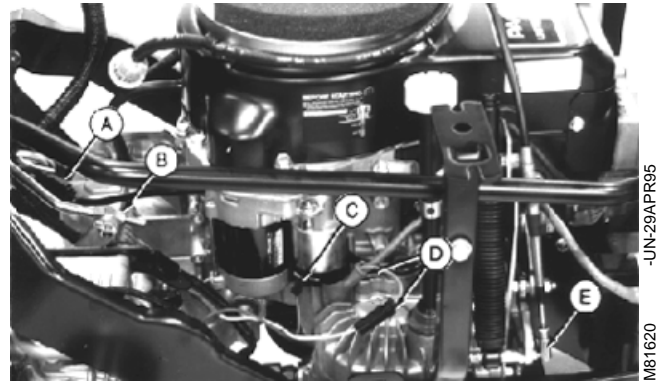

MX,2005CL,A3 -19-23OCT95

9. Install seat platform (B) and fenders. (See Remove and Install Seat Platform in Section 80, Group 15.)

NOTE: Inspect O-rings and nylon bushings before installing mower deck arms. Replace damaged parts. Lubricate O-rings and bushings before installing mower deck arms.

10. Install mower deck arms. Install snap ring (A).

11. Install wheels. (See Remove and Install Wheels in Section 60, Group 10.)

12. Install mower deck.

13. Fill crankcase to correct level with proper oil. (See Engine Oil in Section 10, Group 20.)

14. Connect battery cables.

15. Open fuel shut-off valve (C).

16. Adjust throttle. (See Throttle Cable Adjustment in Section 220, Group 15.)

17. Adjust shift linkage. (See Direction Pedal Travel Adjustment and Direction Pedal Neutral Adjustment in Section 250, Group 15.)

18. Adjust brake pedal travel (See Brake Travel Adjustment in Section 265, Group 20.)

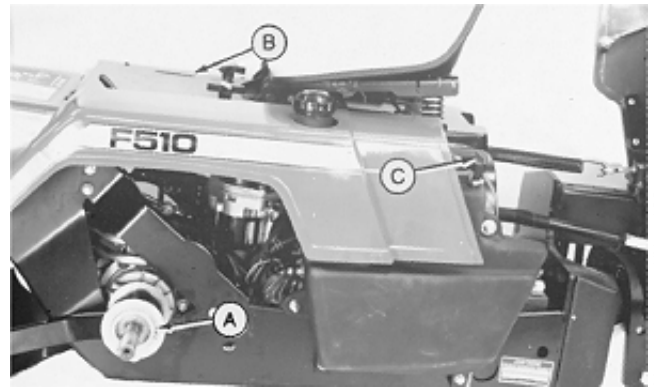

M53037 -UN-13APR89

20
5

ENGINE CONFIGURATION CHART

The PA420A and PA540A engines have an engine configuration number following the engine model number to help separate engine changes. Use the engine configuration number to determine the proper service specifications and procedures to follow in this technical manual.

ENGINE CONFIGURATION CHART

F510 (Engine S.N. -3887)	PA420A-AS00
(Engine S.N. 3888-4898)	PA420A-BS00
(Engine S.N. 4899-7322)	PA420A-AS01
(Engine S.N. 7323-)	PA420A-AS02
F525 (Engine S.N. -7891)	PA540A-AS00
(Engine S.N. 7892-11999)	PA540A-BS00
(Engine S.N. 12000-21944)	PA540A-AS01
(Engine S.N. 21945-)	PA540A-AS02

MX,1015CL,1 -19-23OCT95

SERVICE PARTS KITS

The following kits are available through your parts catalog:

- Blower Housing Engine Cover Kit
- Decal Kit
- Flywheel Screen and Spacer Kit
- Dipstick Tube Kit

MX,2010CL,A0 -19-04MAY92



Suggest:

If the above button click is invalid.

Please download this document first, and then click the above link to download the complete manual.

Thank you so much for reading

REMOVE AND INSTALL BLOWER HOUSING

1. Disconnect spark plug cap.
2. Remove air cleaner assembly.
3. Remove fuel pump. (See Remove and Install Fuel Pump in Section 30, Group 10.)
4. Remove cover (A).
5. Remove dipstick tube.
6. Remove protector and screen (D).
7. Remove blower housing (C).
8. Install blower housing, screen and protector.
9. Adjust flywheel screen. (See Flywheel Screen Adjustment in this group.)
10. Install cylinder head cover and dipstick tube.
11. Install fuel pump.
12. Install air cleaner assembly.

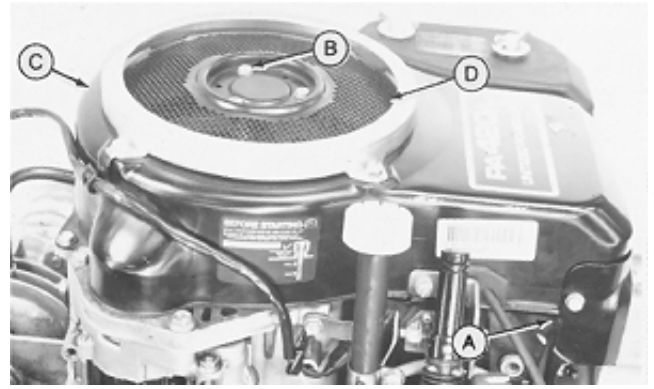

A—Cylinder Head Cover
 B—Flywheel Screen Screws
 C—Blower Housing
 D—Flywheel Screen

20
10
2

M53040 -UN-13APR89

MX,2010CL,A2 -19-23OCT95

FLYWHEEL SCREEN ADJUSTMENT

Adjust gap (C) between the blades under screen (A) and blower housing (B) to specifications using spacers from Flywheel Screen and Spacer Kit.

SPECIFICATIONS

Minimum Gap 1.5 mm (0.059 in.)

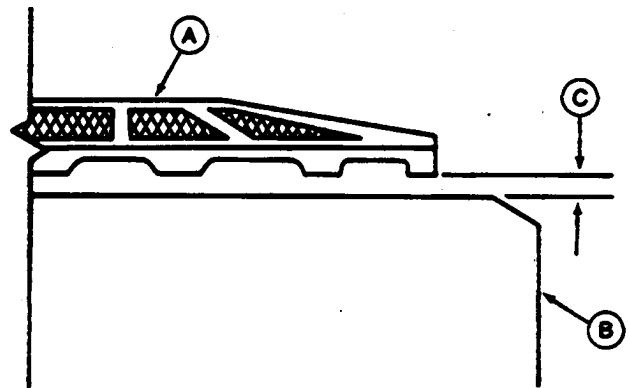

MX,2010CL,A2A -19-23OCT95

M38037 -UN-29AUG88

<https://www.ebooklibonline.com>

Hello dear friend!

Thank you very much for reading.

Enter the link into your browser.

The full manual is available for immediate download.

<https://www.ebooklibonline.com>