

8560 8760, and 8960 Tractors Repair

For complete service information also see:

8560, 8760, and 8960 Tractors

Operation and Tests TM1434

6076 Engine

Serial Number (-499999) CTM6

Serial Number (500000-) CTM42

6101 Engine CTM20

Radial Piston Pumps CTM7

Engine Accessories CTM11

1600 Series Axles CTM18

John Deere Waterloo Works
TM1433 (19JUL01)

LITHO IN U.S.A.
ENGLISH

Introduction

FOREWORD

This manual is written for an experienced technician. Essential tools required in performing certain service work are identified in this manual and are recommended for use.

Live with safety: Read the safety messages in the introduction of this manual and the cautions presented throughout the text of the manual.



This is the safety-alert symbol. When you see this symbol on the machine or in this manual, be alert to the potential for personal injury.

Technical manuals are divided in two parts: repair and diagnostics. Repair sections tell how to repair the components. Diagnostic sections help you identify the majority of routine failures quickly.

Information is organized in groups for the various components requiring service instruction. At the beginning of each group are summary listings of all applicable essential tools, service equipment and tools, other materials needed to do the job, service parts kits, specifications, wear tolerances, and torque values.

Binders, binder labels, and tab sets can be ordered by John Deere dealers direct from the John Deere Distribution Service Center.

This manual is part of a total product support program.

FOS MANUALS—REFERENCE

TECHNICAL MANUALS—MACHINE SERVICE

COMPONENT MANUALS—COMPONENT SERVICE

Fundamentals of Service (FOS) Manuals cover basic theory of operation, fundamentals of troubleshooting, general maintenance, and basic type of failures and their causes. FOS Manuals are for training new personnel and for reference by experienced technicians.

Technical Manuals are concise guides for specific machines. Technical manuals are on-the-job guides containing only the vital information needed for diagnosis, analysis, testing, and repair.

Component Technical Manuals are concise service guides for specific components. Component technical manuals are written as stand-alone manuals covering multiple machine applications.

NOTICE TO THE DEALER

IMPORTANT: The changes listed below make your current TM obsolete. Discard TM1433 dated 23MAY91. Please make this information available to your service department.

• SECTION 20—

Dynamometer Test moved to TM1434

• SECTION 30—

Some information has been eliminated since it appears in the Operator's Manual

• SECTION 40—

Added New Wiring Harnesses
Added Hitch Draft Sensing

• SECTION 50—

24-Speed MST Hi-Lo Clutch Changes
Revised Section 50 Groups

• SECTION 55—

Revised Transmission Repair Procedures

• SECTION 60—

Added Steering Valve Warm-up Check Valve

• SECTION 70—

Added New Hydraulic Circuit
Revised Section 70 Groups

• SECTION 80—

Revised Wheels—Group 05

• SECTION 90—

Revised Air Quality System Repair

Major revisions to this TM are listed above. Some Sections and Groups will have specification, procedure, or formatting changes not listed on this notification.

RX, TM1433, DLR -19-09MAR92

<https://www.ebooklibonline.com>

Hello dear friend!

Thank you very much for reading.

Enter the link into your browser.

The full manual is available for immediate download.

<https://www.ebooklibonline.com>

Contents

SECTION 05—SAFETY

Group 05—Safety

SECTION 10—GENERAL INFORMATION

Group 05—Machine Specifications

Group 10—Predelivery

Group 15—Tune-up

Group 20—Lubrication

SECTION 15—Component Removal

Group 00—Major Components

Group 05—Front Axles and Final Drives

Group 10—Rear Axles and Final Drives

Group 15—Engine

Group 20—SOUND-GARD Body

Group 25—Mechanical Shift Transmission

Group 30—Power Shift Transmission

SECTION 20—ENGINES

Group 05—Engine Service

Group 10—Cooling System

SECTION 30—FUEL AND AIR SYSTEMS

Group 05—Air Intake System

Group 10—Diesel Fuel System

SECTION 40—ELECTRICAL

Group 01—Batteries

Group 05—Electrical Components and Wiring
Harnesses

Group 10—Connectors

Group 15—Alternator

Group 20—Starting Circuit

Group 25—Lighting Circuit

Group 30—INTELLITRAK Monitoring System

Group 35—Accessory Components

Group 40—Hitch Electronic Control Components

Group 45—PST Electronic Control Components

SECTION 50—MECHANICAL SHIFT TRANSMISSION

Group 05—Transmission Oil Filter Relief Valve
Housing

Group 10—Transmission Control Valve Housing

Group 15—Transmission Pump

Group 20—Transmission Front Cover

Group 25—Hi-Lo Clutch and Brake (24-Speed)

Group 30—Hi-Lo Planetary (24-Speed)

Group 35—Spacer Housing

Group 40—Traction Clutch

Group 45—Transmission Gear Train

Group 50—Transmission Clean-Up

Group 55—Shift Levers and Linkage

SECTION 55—POWER SHIFT TRANSMISSION

Group 05—Transmission Oil Filter Relief Valve
Housing and Oil Pump

Group 10—Transmission Pressure Regulating
Valve

Group 15—On-Off and Modulating Shift Solenoids

Group 20—8-Inch Clutch Assembly

Group 25—Lower 7-Inch Clutch Assembly

Group 30—Upper 7-Inch Clutch Assembly

Group 35—Compound Shaft Assembly

Group 40—9-Inch Clutch Assembly

Group 45—Front and Rear Housings

Group 50—Transmission Clean-Up

Group 55—Shift Selector Assembly

SECTION 56—POWER TRAIN COMPONENTS

Group 05—Engine Coupler

Group 10—Drive Shafts

Group 15—PTO Clutch

Group 20—PTO Clutch Valve and Linkage

Group 25—PTO Drop Box

SECTION 60—STEERING AND BRAKES

Group 05—Steering Column

Group 10—Metering Pump

Group 15—Steering Valve

Group 20—Steering Cylinder

Group 25—Feedback Cylinder

Continued on next page

All information, illustrations and specifications in this manual are based on the latest information available at the time of publication. The right is reserved to make changes at any time without notice.

TM1433-19-19JUL01

COPYRIGHT© 1992
DEERE & COMPANY
Moline, Illinois

All rights reserved
A John Deere ILLUSTRATION® Manual
Previous Editions
Copyright 1991, 1990 Deere & Company

Group 30—Brake Valve and Brake Accumulator

05

SECTION 70—HYDRAULICS

Group 05—Hydraulic System Repair

Group 10—Main Hydraulic Pump

Group 15—Axle Lube and Charge Pumps
(P.I.N. -XXXX)

10

Group 20—Charge-Lube Pump (P.I.N. XXXX-)

Group 25—Filter Housing, Bypass Valves, and
Reservoir (P.I.N. -XXXX)

Group 30—Filter Housing, Bypass Valves, and
Reservoir (P.I.N. XXXX-)

15

Group 35—Oil Cooler and Control Valves

Group 40—Hitch

Group 45—Hitch Valve and Selective Control
Valves

Group 50—Lift Cylinders

20

Group 55—Hydraulic System Clean-up

Group 60—Remote Cylinder

SECTION 80—MISCELLANEOUS

Group 05—Wheels

Group 10—Gudgeon

30

SECTION 90—OPERATOR STATION

Group 05—Air Conditioning System Repair

Group 10—Air Conditioning System Service

Group 15—HYDRACUSHION Seat

40

Group 20—Miscellaneous Components

SECTION 99—DEALER FABRICATED TOOLS

Group 05—Fabricated Tools

50

Index

55

56

60

Section 05 SAFETY

05

Contents

Page

Group 05—Safety	05-05-1
-----------------------	---------

HANDLE FLUIDS SAFELY—AVOID FIRES

When you work around fuel, do not smoke or work near heaters or other fire hazards.

Store flammable fluids away from fire hazards. Do not incinerate or puncture pressurized containers.

Make sure machine is clean of trash, grease, and debris.

Do not store oily rags; they can ignite and burn spontaneously.



DX,FLAME -19-04JUN90

TS227 -JUN-23AUG88

05
1

PREVENT BATTERY EXPLOSIONS

Keep sparks, lighted matches, and open flame away from the top of battery. Battery gas can explode.

Never check battery charge by placing a metal object across the posts. Use a volt-meter or hydrometer.

Do not charge a frozen battery; it may explode. Warm battery to 16°C (60°F).

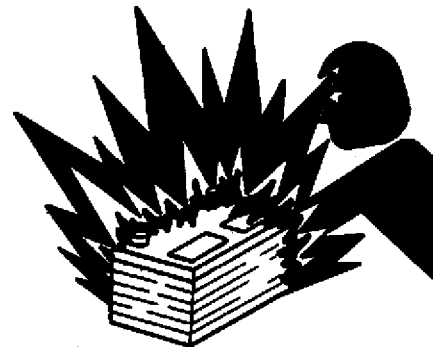

DX,SPARKS -19-04JUN90

TS204 -JUN-23AUG88

PREPARE FOR EMERGENCIES

Be prepared if a fire starts.

Keep a first aid kit and fire extinguisher handy.

Keep emergency numbers for doctors, ambulance service, hospital, and fire department near your telephone.

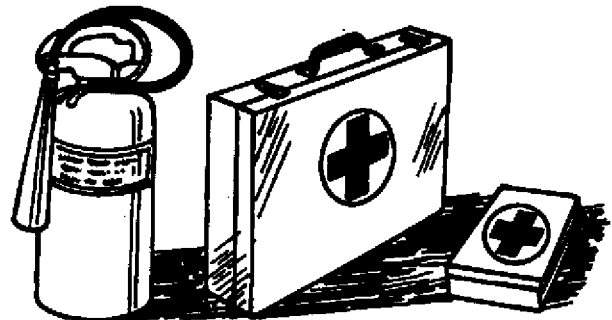

DX,FIRE2 -19-04JUN90

TS291 -JUN-23AUG88

PREVENT ACID BURNS

Sulfuric acid in battery electrolyte is poisonous. It is strong enough to burn skin, eat holes in clothing, and cause blindness if splashed into eyes.

Avoid the hazard by:

1. Filling batteries in a well-ventilated area.
2. Wearing eye protection and rubber gloves.
3. Avoiding breathing fumes when electrolyte is added.
4. Avoiding spilling or dripping electrolyte.
5. Use proper jump start procedure.

If you spill acid on yourself:

1. Flush your skin with water.
2. Apply baking soda or lime to help neutralize the acid.
3. Flush your eyes with water for 10—15 minutes. Get medical attention immediately.

If acid is swallowed:

1. Drink large amounts of water or milk.
2. Then drink milk of magnesia, beaten eggs, or vegetable oil.
3. Get medical attention immediately.

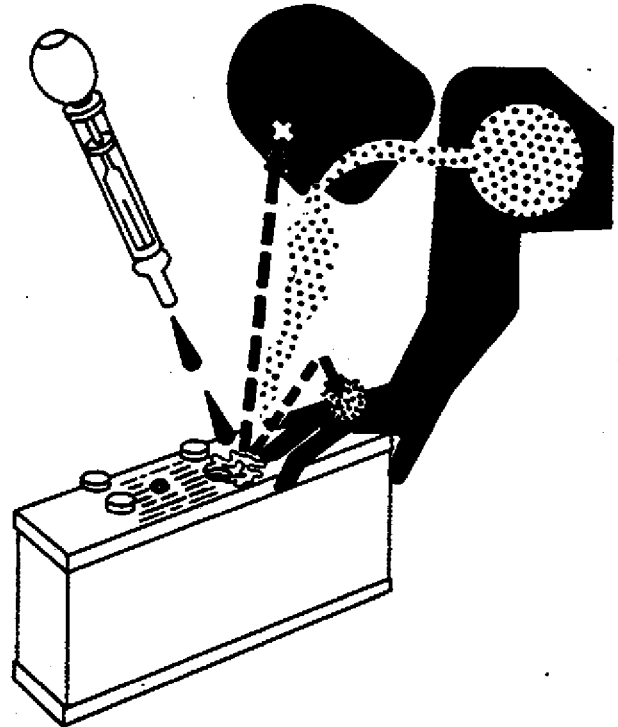

DX, POISON -19-04JUN90

TS203 -UN-23AUG88

HANDLE CHEMICAL PRODUCTS SAFELY

Direct exposure to hazardous chemicals can cause serious injury. Potentially hazardous chemicals used with John Deere equipment include such items as lubricants, coolants, paints, and adhesives.

A Material Safety Data Sheet (MSDS) provides specific details on chemical products: physical and health hazards, safety procedures, and emergency response techniques.

Check the MSDS before you start any job using a hazardous chemical. That way you will know exactly what the risks are and how to do the job safely. Then follow procedures and recommended equipment.

(See your John Deere dealer for MSDS's on chemical products used with John Deere equipment.)



DX, MSDS, NA -19-15MAR91

TS1132 -UN-26NOV90

AVOID HIGH-PRESSURE FLUIDS

Escaping fluid under pressure can penetrate the skin causing serious injury.

Avoid the hazard by relieving pressure before disconnecting hydraulic or other lines. Tighten all connections before applying pressure.

Search for leaks with a piece of cardboard. Protect hands and body from high pressure fluids.

If an accident occurs, see a doctor immediately. Any fluid injected into the skin must be surgically removed within a few hours or gangrene may result. Doctors unfamiliar with this type of injury should reference a knowledgeable medical source. Such information is available from Deere & Company Medical Department in Moline, Illinois, U.S.A.

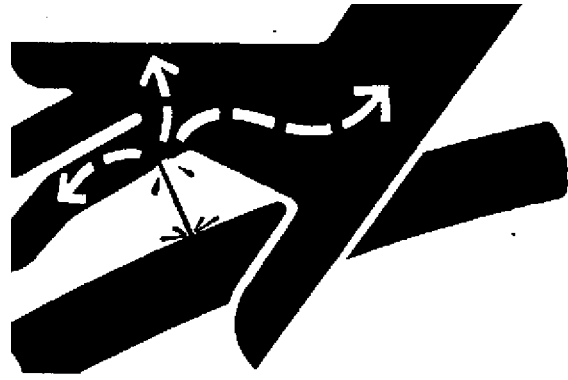

DX,FLUID -19-09AUG91

-JUN-23AUG88

X9811

05
05
3

PARK MACHINE SAFELY

Before working on the machine:

- Lower all equipment to the ground.
- Stop the engine and remove the key.
- Disconnect the battery ground strap.
- Hang a "DO NOT OPERATE" tag in operator station.

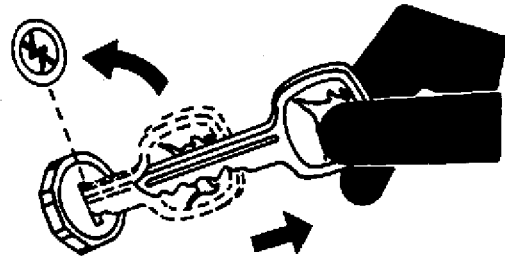

DX,PARK -19-04JUN90

-JUN-24MAY89

TS230

Section 50

MECHANICAL SHIFT TRANSMISSION

Contents

	Page	Page
Group 05—Transmission Oil Filter Relief Valve Housing		
Specifications	50-05-1	
Filter Relief Valve Housing (Early Models)		
Remove	50-05-1	
Disassemble and Assemble	50-05-2	
Install	50-05-2	
Filter Relief Valve Housing (Later Models)		
Remove	50-05-3	
Disassemble and Assemble	50-05-3	
Install	50-05-3	
Group 10—Transmission Control Valve Housing		
Special or Essential Tools	50-10-1	
Service Equipment and Tools	50-10-1	
Other Material	50-10-1	
Specifications	50-10-2	
Transmission Control Valve Housing		
Remove	50-10-3	
Cross-Sectional View	50-10-4	
Exploded View	50-10-5	
Disassemble, Inspect, and Assemble	50-10-6	
Install	50-10-10	
Group 15—Transmission Pump		
Service Equipment and Tools	50-15-1	
Specifications	50-15-1	
Transmission Pump and Bearing Quill		
Remove	50-15-2	
Cross Sectional View	50-15-3	
Exploded View	50-15-4	
Disassemble, Inspect and Assemble	50-15-4	
Install	50-15-6	
Group 20—Transmission Front Cover		
Special or Essential Tools	50-20-1	
Service Equipment and Tools	50-20-1	
Other Material	50-20-1	
Specifications	50-20-2	
Transmission Front Cover		
Remove	50-20-2	
Remove, Inspect, and Install Parts	50-20-6	
Install	50-20-10	
Group 25—Hi-Lo Clutch and Brake (24-Speed)		
Special or Essential Tools	50-25-1	
Service Equipment and Tools	50-25-2	
Other Material	50-25-2	
Specifications	50-25-3	
Hi-Lo Brake and Clutch		
Cross-Sectional and Exploded Views	50-25-4	
Remove	50-25-8	
Disassemble, Inspect, and Assemble	50-25-9	
Install	50-25-17	
Group 30—Hi-Lo Planetary (24-Speed)		
Special and Essential Tools	50-30-1	
Specifications	50-30-1	
Hi-Lo Planetary		
Cross-Sectional and Exploded Views	50-30-2	
Remove	50-30-5	
Disassemble, Inspect, and Assemble	50-30-6	
Install	50-30-9	
Group 35—Spacer Housing		
Other Material	50-35-1	
Spacer Housing		
Remove, Inspect, and Install	50-35-1	
Group 40—Traction Clutch		
Service Equipment and Tools	50-40-1	
Other Material	50-40-1	
Specifications	50-40-2	
Traction Clutch Assembly		
Remove	50-40-3	
Cross-Sectional View	50-40-4	
Exploded View	50-40-5	
Disassemble, Inspect, and Assemble	50-40-6	
Traction Clutch Manifold		
Remove and Inspect	50-40-9	
Install	50-40-10	
Install Traction Clutch Assembly	50-40-10	
Group 45—Transmission Gear Train		
Service Equipment and Tools	50-45-1	
Other Material	50-45-1	

Continued on next page

	Page		Page
Specifications	50-45-2	Adjust Transmission Shift Linkage	50-55-9
Transmission Gear Train-Sectional View	50-45-4	Adjust Neutral Lockout Plate	50-55-10
Remove Transmission Shafts	50-45-5	Adjust Hi-Lo Switch (24-Speed)	50-55-11
Top Shaft-Sectional and Exploded Views	50-45-7		
Upper Countershaft-Sectional and Exploded Views	50-45-8		
Lower Countershaft Assembly	50-45-9		
Output Shaft-Cross-Sectional and Exploded Views	50-45-10		
Disassemble and Inspect Shafts	50-45-11		
Assemble Top Shaft and Lower Countershaft	50-45-12		
Disassemble and Inspect Synchronizer	50-45-12		
Assemble Synchronizer	50-45-14		
Install Upper Countershaft Bearing Retainer	50-45-15		
Park Pawl Assembly Disassemble and Assemble	50-45-16		
Cross-Sectional and Exploded Views	50-45-17		
Adjust	50-45-18		
Shifter Cams Cross-Sectional and Exploded Views	50-45-19		
Remove and Install	50-45-20		
Adjust Neutral Start Switch	50-45-22		
Disassemble and Assemble Shifter Forks	50-45-22		
Remove and Install Front Case Parts	50-45-23		
Remove and Install Reverse Idler Gear	50-45-23		
Install Transmission Shafts	50-45-25		
Install Rear Case	50-45-26		
Adjust Shaft End Play	50-45-28		
Install Yoke Seals and Yokes	50-45-30		
 Group 50—Transmission Clean-Up			
Service Equipment and Tools	50-50-1		
Other Material	50-50-1		
Perform Transmission Clean-Up	50-50-2		
 Group 55—Shift Levers and Linkage			
Service Equipment and Tools	50-55-1		
Service Parts Kits	50-55-1		
Specifications	50-55-1		
Shifter Arm Support Assembly Remove	50-55-2		
Disassemble, Inspect, and Assemble	50-55-2		
Install	50-55-6		
Bellcrank Assembly Remove, Disassemble, and Assemble	50-55-6		
Install	50-55-8		

50

SPECIFICATIONS

Item	Measurement	Specification
Filter Relief Valve Spring	Free Length	76 mm (3.0 in.) (approx.)
	Test Length	49.3 mm at 51.6—56.9 N (1.9 in. at 11.6—12.8 lb force)
Filter Relief Valve Housing-to-Bracket (<i>Early Models</i>)	Torque	48 N·m (35 lb-ft)
Filter Relief Valve Housing-to-Cover (<i>Later Models</i>)	Torque	74 N·m (55 lb-ft)

RX14335005,1B -19-15NOV91

**REMOVE FILTER RELIEF VALVE HOUSING
(EARLY MODELS)**

1. Disconnect filter restriction sensor lead (A) and remove sensor leak-off line (C).
2. Remove filter housing-to-control valve line (B) and pump-to-filter housing line (D).
3. Remove cap screws (E) to remove filter relief valve housing.

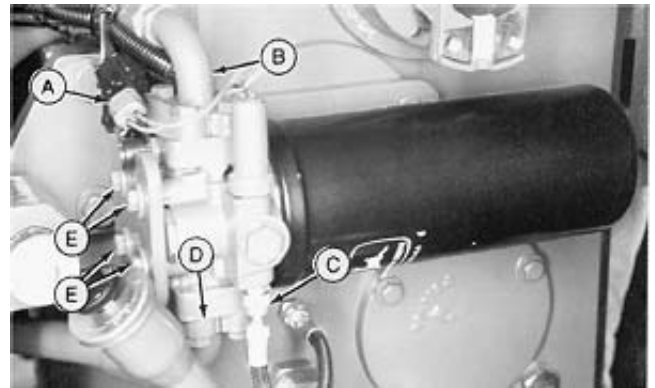

- A—Filter Restriction Sensor Connector
- B—To Control Valve
- C—Leak-Off Line
- D—From Pump
- E—Cap Screws

RX14335005,2 -19-05MAR91

-UN-24FEB89
RW14659

50
05
1

DISASSEMBLE AND ASSEMBLE FILTER RELIEF VALVE HOUSING

NOTE: The filter restriction valve assembly and the fitting with orifice are used only on early model tractors.

Parts (A—C) are serviceable only as a kit.

1. Remove plug (C) to remove filter restriction valve (A) and spring (B). Inspect parts for excessive wear or damage. Replace the valve, spring, and plug as a set.

NEW SPRING SPECIFICATION

Free Length 76 mm (3.0 in.) (approximate)
 Test Length 49.3 mm at 51.6—56.9 N
 (1.9 in. at 11.6—12.8 lb force)

2. Remove fitting (D) containing an orifice for sensor leak-off circuit. Make sure the orifice is open and clean.

- A—Valve
- B—Spring
- C—Plug
- D—Fitting with Orifice

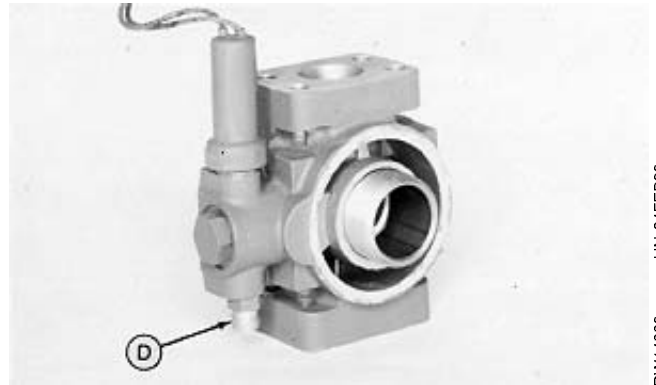
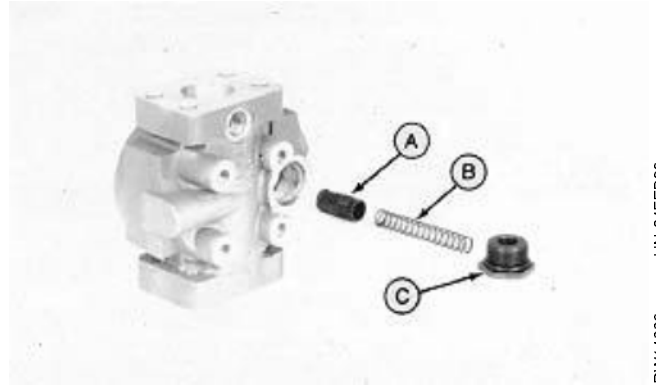

RX14335005,3 -19-06MAY91

-JUN-24FEB89
RW14660

-JUN-24FEB89
RW14663

INSTALL FILTER RELIEF VALVE HOUSING (EARLY MODELS)

1. Install relief valve housing on bracket and tighten cap screws (E).

TORQUE SPECIFICATION

Filter Relief Valve
 Housing-to-Bracket Cap Screws 48 N·m (35 lb-ft)

2. Connect filter housing-to-control valve line (B) and pump-to-filter housing line (D).
3. Connect sensor leak-off line (C).
4. Connect sensor lead (A).

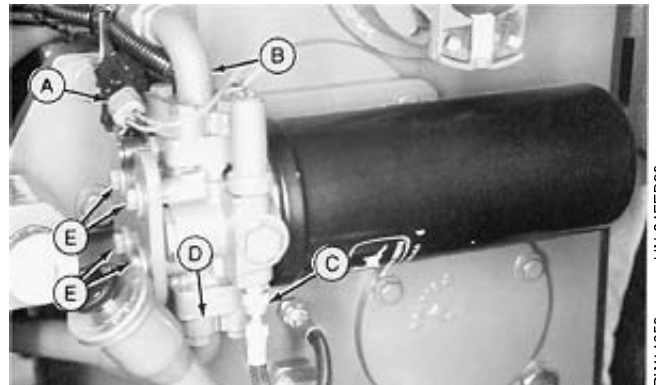

- A—Filter Restriction Sensor Connector
- B—To Control Valve
- C—Leak-Off Line
- D—From Pump
- E—Cap Screws

RX14335005,2B -19-15NOV91

-JUN-24FEB89
RW14659

50
05
2

REMOVE FILTER RELIEF VALVE HOUSING (LATER MODELS)

1. Disconnect filter restriction sensor lead (A).
2. Remove pump-to-filter housing line (B).
3. Remove four housing-to-front cover cap screws (C) and remove housing.
4. Scrape and clean gasket surface on cover and housing.

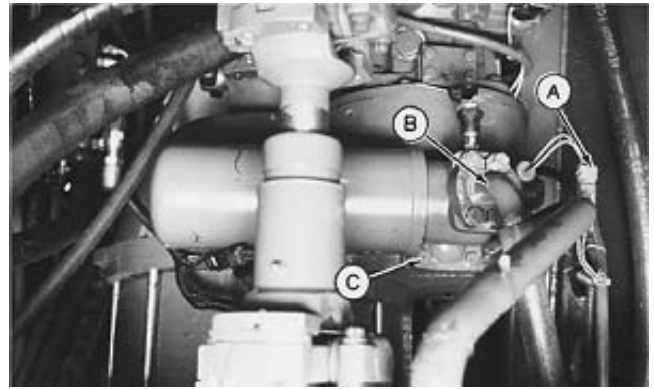

-JUN-28JAN91
RW18797

RX14335005.5 -19-15NOV91

DISASSEMBLE AND ASSEMBLE FILTER RELIEF VALVE HOUSING (LATER MODELS)

NOTE: Parts (A—C) are serviceable as a kit.

1. Remove plug (A) to remove filter restriction valve (C) and spring (B). Inspect parts for excessive wear or damage. Replace the valve, spring and plug as a set.

NEW SPRING SPECIFICATION

Free Length	76 mm (3.00 in.) (approximate)
Test Length	49.3 mm at 51.6—56.9 N (1.9 in. at 11.6—12.8 lb-force)

2. Make sure relief passage (D) is open.

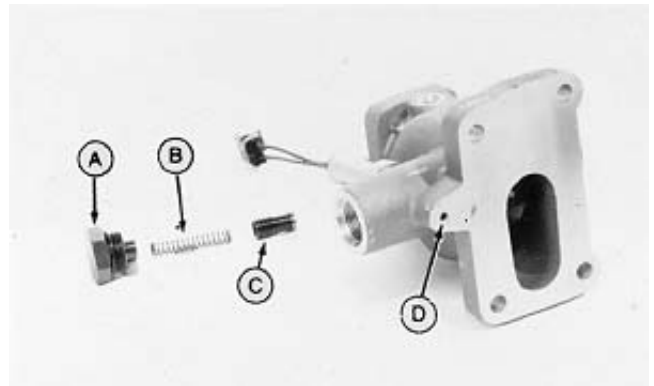

- A—Plug with O-Ring
- B—Spring
- C—Valve
- D—Relief Passage

-JUN-28JAN91
RW18777

RX14335005.6 -19-04FEB91

INSTALL FILTER RELIEF VALVE HOUSING (LATER MODELS)

1. Install new gasket and housing onto cover and tighten four cap screws (C) to 74 N·m (55 lb-ft).
2. Connect pump to filter housing line (B).
3. Connect sensor lead (A).

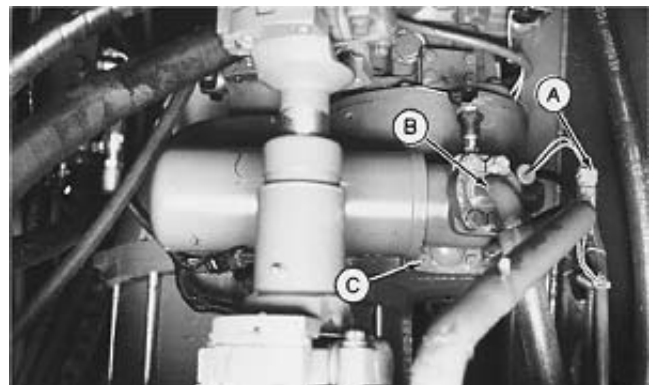

-JUN-28JAN91
RW18797

RX14335005.3B -19-15NOV91

Group 10 Transmission Control Valve Housing

SPECIAL OR ESSENTIAL TOOLS

NOTE: Order tools according to information given in the U.S. SERVICE-GARD™ Catalog or in the European Microfiche Tool Catalog (MTC).

DX,TOOLS -19-05JUN91

Box End Adapter JDG669

RW17445 -UN-16NOV89

Remove and install transmission pressure sensor

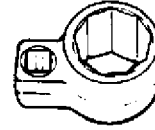

JDG669A -19-11APR90

SERVICE EQUIPMENT AND TOOLS

NOTE: Order tools from the U.S. SERVICEGARD™ Catalog or from the European Microfiche Tool Catalog (MTC). Some tools may be available from a local supplier.

Name	Use
D01045AA Bushing, Bearing and Seal Driver Set	Install oil seal and bearing for clutch valve arm shaft

RX14335010.1 -19-12APR90

OTHER MATERIAL

Number	Name	Use
TY9375 (TY9374*)	Pipe Sealant	Install transmission lube orifice and Hi-Lo control oil port plug

* Smaller Size

RX14335010.2 -19-12APR90

50
10
1

SPECIFICATIONS

Item	Measurement	Specification
Clutch Valve Springs	Free Length—Outer (Longer) Test Length	56 mm (2.2 in.) (approx.) 47 mm at 201—307 N (1.85 in. at 45—53 lb force)
	Free Length—Inner (Shorter) Test Length	54 mm (2.1 in.) (approx.) 39 mm at 113—133 N (1.5 in. at 25—30 lb force)
Clutch Valve	OD	15.840—15.856 mm (0.6236—0.6243 in.)
	Bore ID	15.881—15.907 mm (0.6252—0.6263 in.)
Engagement Override Valve Spring	Free Length Test Length	29.5 mm (1.2 in.) (approx.) 21 mm at 26—32 N (0.8 in. at 5.8—7.1 lb force)
	Engagement Override Valve	OD
Engagement Override Valve	Bore ID	13.987—14.013 mm (0.5507—0.5517)
	Clutch Lube Valve Spring	Free Length Test Length
Clutch Lube Valve		OD
	Clutch Lube Valve	Bore ID
Pressure Regulating Valve Spring		Free Length Test Length
	Pressure Regulating Valve	OD
Pressure Regulating Valve	Bore ID	15.862—15.888 mm (0.6245—0.6255 in.)
Lube Relief Valve Spring	Free Length Test Length	52 mm (2.0 in.) (approx.) 37 mm at 20—24 N (1.5 in. at 4.5—5.5 lb force)

Continued on next page

Item	Measurement	Specification
Lube Relief Valve	OD	22.212—22.236 mm (0.8745—0.8755 in.)
	Bore ID	22.288—22.314 mm (0.8775—0.8785 in.)
Transmission Control Valve Housing-to-Case	Torque	24 N·m (18 lb-ft)

RX14335010,1B -19-15NOV91

REMOVE TRANSMISSION CONTROL VALVE HOUSING

⚠ CAUTION: Escaping fluid under pressure can penetrate the skin causing serious injury. Relieve pressure before disconnecting hydraulic or other lines. Tighten all connections before applying pressure. Keep hands and body away from pinholes and nozzles which eject fluids under high pressure. Use a piece of cardboard or paper to search for leaks. Do not use your hand.

If ANY fluid is injected into the skin, it must be surgically removed within a few hours by a doctor familiar with this type injury or gangrene may result.

1. Relieve hydraulic pressure by stopping engine and operating all hydraulic control valves.
2. Remove and cap cooler lines (A) and filter line (D).
3. Remove clutch valve spring (C). Remove lube pressure sensor (B) using JDG669 Box End Adapter.
4. Remove 20 cap screws to remove control valve housing.

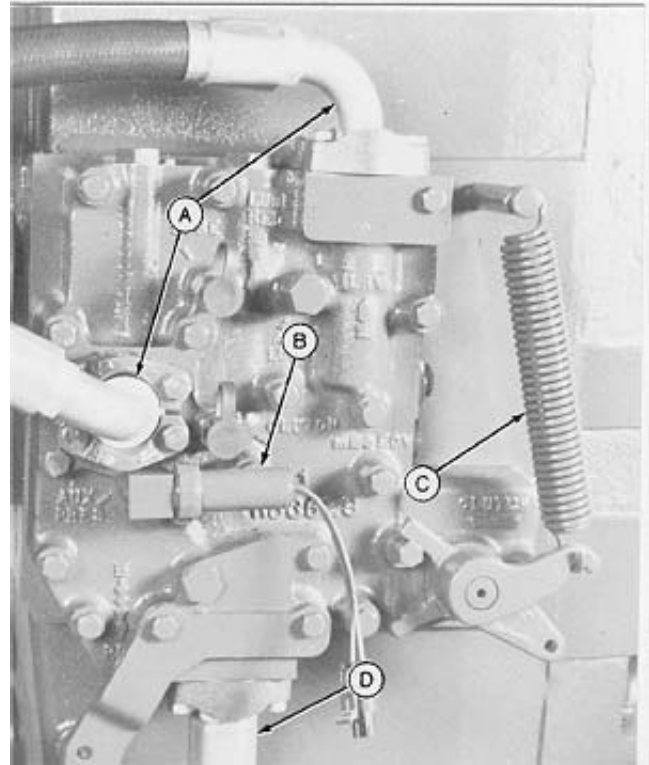

A—Oil Cooler Lines
B—Lube Oil Pressure Sensor
C—Clutch Valve Spring
D—Oil Filter Line

RX14335010,4 -19-12APR90

RW14447 -UN-24FEB89

50
10
3

TRANSMISSION CONTROL VALVE—CROSS-SECTIONAL VIEW

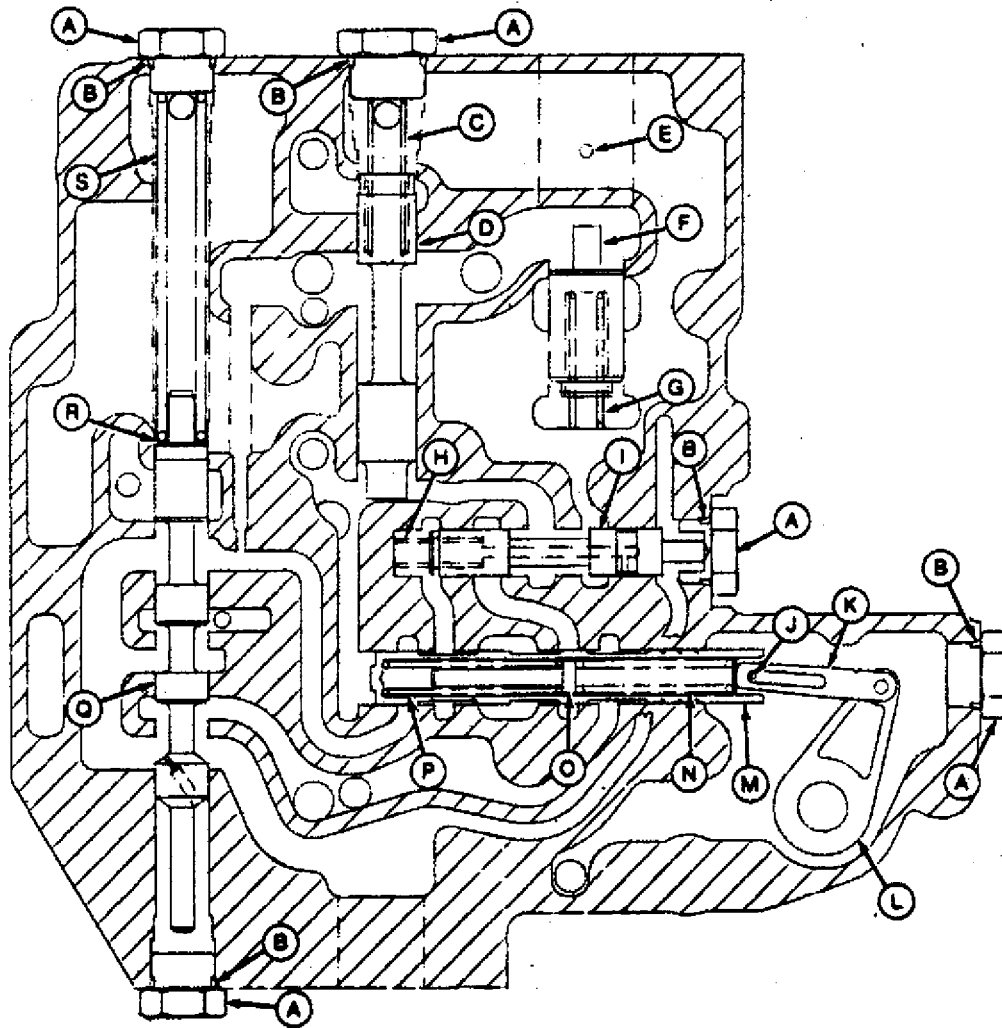

RW13798 -JUN-24FEB89

- | | | | |
|---------------------|-----------------------------|----------------|-----------------------------|
| A—Plug | G—Spring | K—Link | P—Spring |
| B—O-Ring | H—Spring | L—Inner Arm | Q—Pressure Regulating Valve |
| C—Spring | I—Engagement Override Valve | M—Clutch Valve | R—Shims |
| D—Clutch Lube Valve | J—Pin | N—Spring | S—Spring |
| E—Pin | | O—Headed Pin | |
| F—Lube Relief Valve | | | |

RX14335010.5 -19-12APR90

50
10
4

TRANSMISSION CONTROL VALVE—EXPLODED VIEW

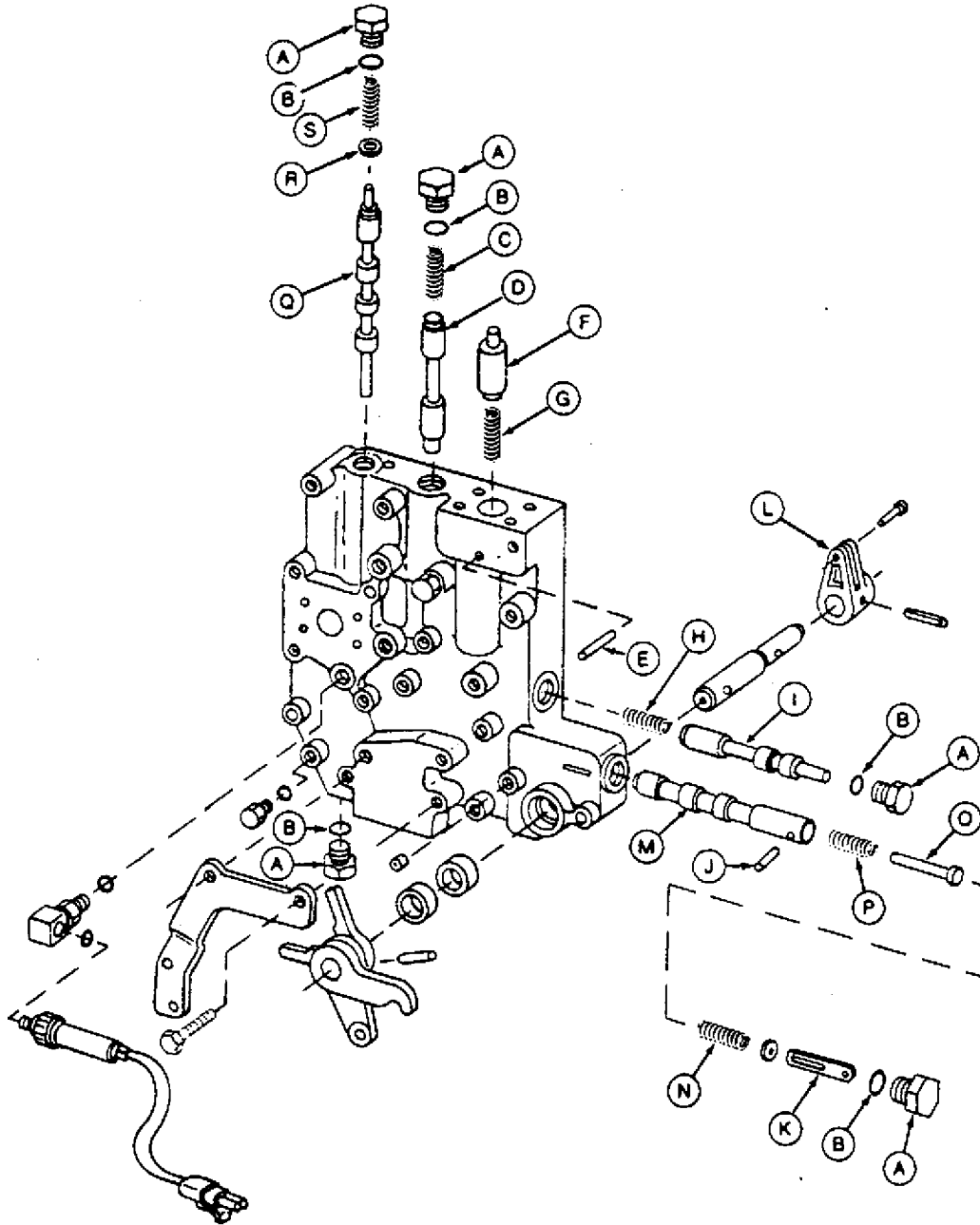

A—Plug
 B—O-Ring
 C—Spring
 D—Clutch Lube Valve
 E—Pin
 F—Lube Relief Valve

G—Spring
 H—Spring
 I—Engagement Override Valve
 J—Pin

K—Link
 L—Inner Arm
 M—Clutch Valve
 N—Spring
 O—Headed Pin

P—Spring
 Q—Pressure Regulating Valve
 R—Shims
 S—Spring

RW14448 -JUN-24FEB89

50-10

RX14335010,6 -19-12APR90

DISASSEMBLE, INSPECT, AND ASSEMBLE TRANSMISSION CONTROL VALVE HOUSING

1. Push pin (A) out to remove operating arm (B).
2. Pull inner arm and shaft (C) out the back of valve housing.

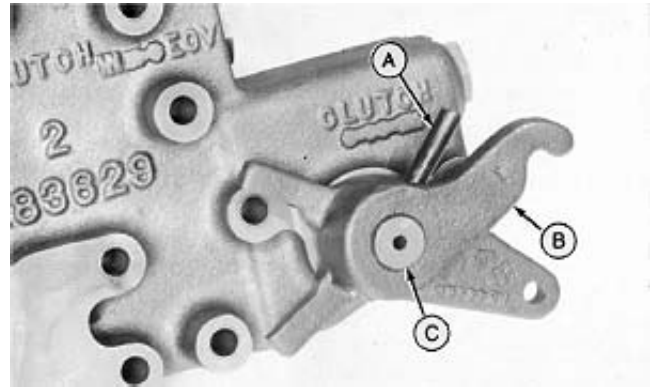

RX14335010,7 -19-12APR90

RW14449 -UN-24FEB89

3. Remove plug (A).
4. Push link (B) into valve (against spring pressure) to remove pin (C) and remove clutch valve.

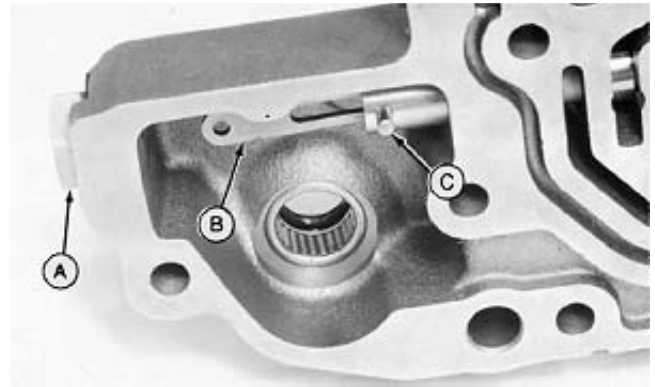

RX14335010,8 -19-12APR90

RW14450 -UN-24FEB89

5. Inspect clutch valve springs (A) and (B).

NEW SPRING SPECIFICATION

Outer (Longer) Spring (A)	
Free Length	56 mm (2.2 in.) (approximate)
Test Length	47 mm at 201—237 N (1.85 in. at 45—53 lb force)
Inner (Shorter) Spring (B)	
Free Length	54 mm (2.1 in.) (approximate)
Test Length	39 mm at 113—133 N (1.5 in. at 25—30 lb force)

NOTE: Inner spring is shorter and must be installed first.

6. Inspect valve (C) OD and valve bore ID for damage or wear.

SPECIFICATION

Valve OD	15.840—15.856 mm (0.6236—0.6243 in.)
Bore ID	15.881—15.907 mm (0.6252—0.6263 in.)

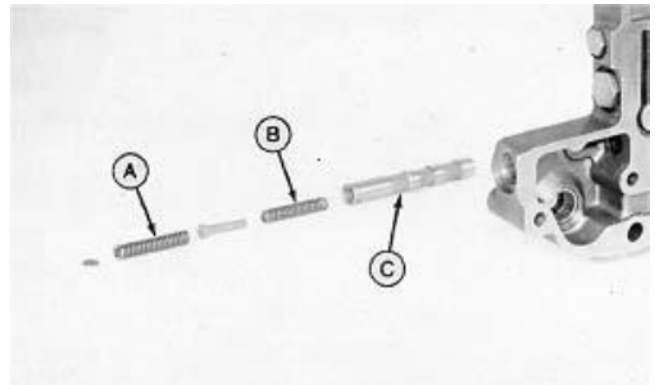

RX14335010,9 -19-12APR90

RW14451 -UN-24FEB89

50
10
6

7. Remove plug (B) to remove engagement override valve (A) and spring (D).

NEW SPRING SPECIFICATION

Free Length 29.5 mm (1.2 in.) (approximate)
 Test Length 21 mm at 26—32 N
 (0.8 in. at 5.8—7.1 lb force)

8. Inspect valve OD and bore ID for damage or wear.

SPECIFICATION

Valve OD 13.916—13.932 mm
 (0.5479—0.5485 in.)
 Bore ID 13.987—14.013 mm
 (0.5507—0.5517 in.)

9. Replace O-ring (C) on plug.

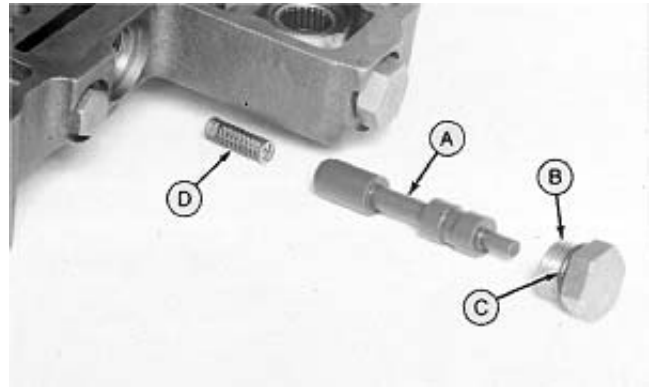

A—Engagement Override Valve
 B—Plug
 C—O-Ring
 D—Spring

RX14335010,10 -19-12APR90

-UN-24FEB89
RW14452

10. Remove plug (A) to remove clutch lube valve spring (B) and valve (C).

NEW SPRING SPECIFICATION

Free Length 48 mm (1.9 in.) (approximate)
 Test Length 30 mm at 55—67 N
 (1.2 in. at 12.5—15.0 lb force)

11. Inspect valve OD and bore ID for damage or wear.

SPECIFICATION

Valve OD 17.399—17.425 mm
 (0.6850—0.6860 in.)
 Bore ID 17.469—17.495 mm
 (0.6878—0.6888 in.)

12. Replace O-ring (D) on plug.

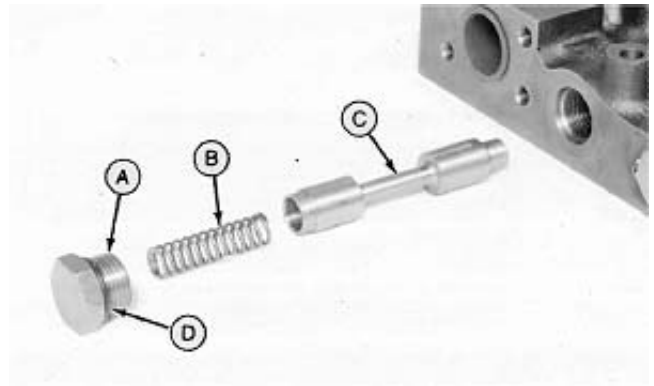

A—Plug
 B—Spring
 C—Clutch Lube Valve
 D—O-Ring

RX14335010,11 -19-12APR90

-UN-24FEB89
RW14453

50
10
7

13. Remove plug (E), pressure regulating valve (C), shim (B) and spring (A).

NEW SPRING SPECIFICATION

Free Length 126 mm (5 in.) (approximate)
 Test Length 100 mm at 308—376 N
 (3.9 in. at 69—85 lb force)

14. Inspect valve OD and bore ID for damage or wear.

SPECIFICATION

Valve OD 15.821—15.834 mm
 (0.6229—0.6235 in.)
 Bore ID 15.862—15.888 mm
 (0.6245—0.6255 in.)

15. Replace O-ring (D) on plug.

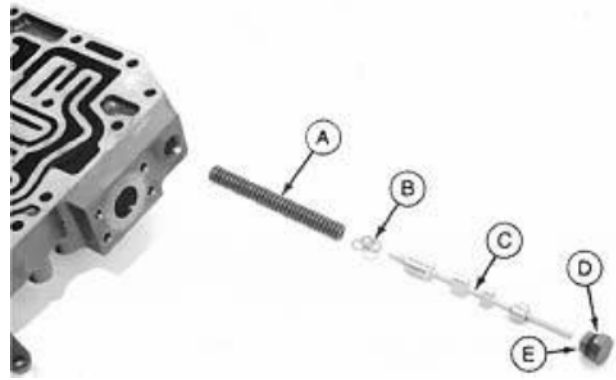

A—Spring
 B—Shim
 C—Pressure Regulating Valve
 D—O-Ring
 E—Plug

-UN-16MAR90
RW14454

RX14335010,12 -19-12APR90

16. Pull retaining pin (A) out, to remove lube relief valve (B) and spring (C).

NEW SPRING SPECIFICATION

Free Length 52 mm (2.0 in.) (approximate)
 Test Length 37 mm at 20—24 N
 (1.5 in. at 4.5—5.5 lb force)

17. Inspect valve OD and bore ID for damage or wear.

SPECIFICATION

Valve OD 22.212—22.238 mm
 (0.8745—0.8755 in.)
 Bore ID 22.288—22.314 mm
 (0.8775—0.8785 in.)

18. Install spring (C), valve (B), and retaining pin (A).

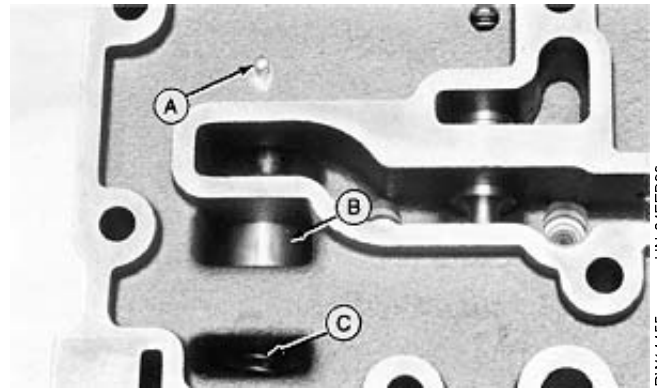

-UN-24FEB89
RW14455

RX14335010,13 -19-12APR90

19. Install seal (A), using a D01045AA Bushing, Bearing and Seal Driver Set, with sealing lip toward inside of housing, flush with finished surface as shown.

20. Coat sealing lip with clean hydraulic oil.



-UN-24FEB89
RW14456

RX14335010,14 -19-12APR90

50
10
8



Suggest:

If the above button click is invalid.

Please download this document

first, and then click the above link

to download the complete manual.

Thank you so much for reading

21. Install roller bearing (A) flush with finished surface on inside of housing.

22. Lubricate roller bearing with clean hydraulic oil.



RX14335010,15 -19-15NOV91

RW14457
-UN-24FEB89

NOTE: Pin is a slip fit.

23. Install pin (A) making sure it does not fall out during installation of the valve housing assembly.

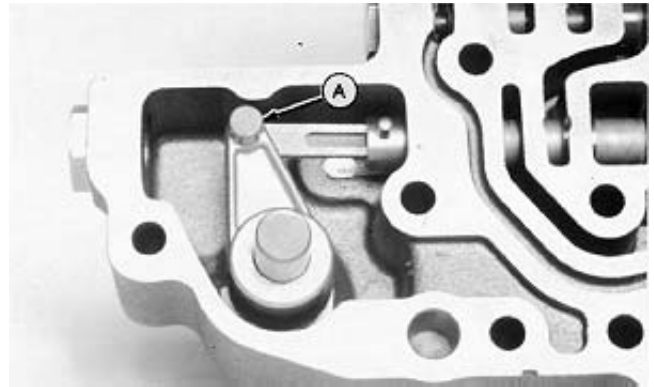

RX14335010,16 -19-12APR90

RW14458
-UN-24FEB89

NOTE: Hi-Lo control oil port (C) is plugged on 12-speed Syncro tractors.

24. Check all oil ports and passages to make sure they are open and clean.

25. Coat threads of orifice (E) (also Hi-Lo control oil port plug (C) on 12-speed Syncro tractors) with TY9375 Pipe Sealant before installing.

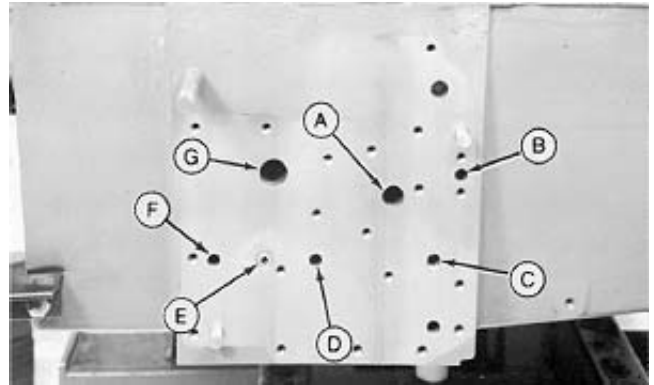

- A—Clutch Valve Sump
- B—Clutch Valve Arm Sump
- C—Hi-Lo Control Oil
- D—Clutch Engagement Pressure
- E—Transmission Lube
- F—Clutch Lube
- G—Lube Relief Valve Sump

RX14335010,17 -19-12APR90

RW14459
-UN-24FEB89

50
10
9

<https://www.ebooklibonline.com>

Hello dear friend!

Thank you very much for reading.

Enter the link into your browser.

The full manual is available for immediate download.

<https://www.ebooklibonline.com>