

# **8875 Skid-Steer Loader**

## **TECHNICAL MANUAL**

**John Deere  
Lawn & Grounds Care Division  
TM1566 (Feb 95)**

This technical manual is written for an experienced technician and contains sections that are specifically for this product. It is a part of a total product support program.

The manual is organized so that all the information on a particular system is kept together. The order of grouping is as follows:

- Table of Contents
- Specifications
- Theory of Operation
- Troubleshooting Diagram
- Diagnostics
- Tests & Adjustments
- Repair

*Note: Depending on the particular section or system being covered, not all of the above groups may be used.*

Each section will be identified with a symbol rather than a number. The groups and pages within a section will be consecutively numbered.

All information, illustrations and specifications in this manual are based on the latest information available at the time of publication. The right is reserved to make changes at any time without notice.

We appreciate your input on this manual. To help, there are postage paid post cards included at the back. If you find any errors or want to comment on the layout of the manual please fill out one of the cards and mail it back to us.

**Safety**



**Specifications and Information**



**Engine (Diesel)**



**Electrical**



**Power Train**



**Power Train (Hydrostatic)**



**Steering**



**Brakes**



**Hydraulics**



**Backhoe**



**Miscellaneous**

**M**



## HANDLE FLUIDS SAFELY-AVOID FIRES

- BE PREPARED FOR EMERGENCIES

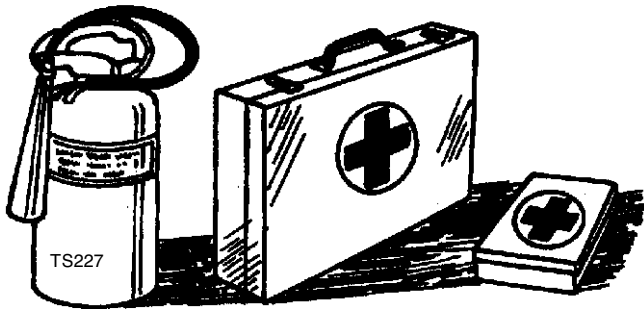

When you work around fuel, do not smoke or work near heaters or other fire hazards.

Store flammable fluids away from fire hazards. Do not incinerate or puncture pressurized containers.

Make sure machine is clean of trash, grease, and debris.

Do not store oily rags; they can ignite and burn spontaneously.

Be prepared if a fire starts.

Keep a first aid kit and fire extinguisher handy.

Keep emergency numbers for doctors, ambulance service, hospital, and fire department near your telephone.

## HANDLE CHEMICAL PRODUCTS SAFELY

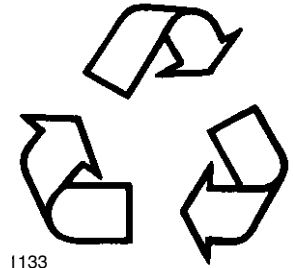

Direct exposure to hazardous chemicals can cause serious injury. Potentially hazardous chemicals used with John Deere equipment include such items as lubricants, coolants, paints, and adhesives.

A Material Safety Data Sheet (MSDS) provides specific details on chemical products: physical and health hazards, safety procedures, and emergency response techniques. Check the MSDS before you start any job using a hazardous chemical. That way you will know exactly what the risks are and how to do the job safely. Then follow procedures and recommended equipment.

- DISPOSE OF WASTE PROPERLY

Improperly disposing of waste can threaten the environment and ecology. Potentially harmful waste used with John Deere equipment include such items as oil, fuel, coolant, brake fluid, filters, and batteries. Use leakproof containers when draining fluids. Do not use food or beverage containers that may mislead someone into drinking from them. Do not pour waste onto the ground, down a drain, or into any water source. Inquire on the proper way to recycle or dispose of waste from your local environmental or recycling center, or from your John Deere dealer.

**<https://www.ebooklibonline.com>**

Hello dear friend!

Thank you very much for reading.

Enter the link into your browser.

The full manual is available for immediate download.

**<https://www.ebooklibonline.com>**

## USE CARE AROUND HIGH-PRESSURE FLUID LINES

### • AVOID HIGH-PRESSURE FLUIDS

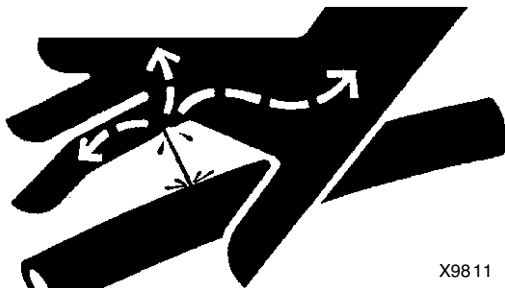

X9811

Escaping fluid under pressure can penetrate the skin causing serious injury.

Avoid the hazard by relieving pressure before disconnecting hydraulic or other lines. Tighten all connections before applying pressure.

Search for leaks with a piece of cardboard. Protect hands and body from high pressure fluids.

If an accident occurs, see a doctor immediately. Any fluid injected into the skin must be surgically removed within a few hours or gangrene may result. Doctors unfamiliar with this type of injury should reference a knowledgeable medical source. Such information is available from Deere & Company Medical Department in Moline, Illinois, U.S.A.

### • AVOID HEATING NEAR PRESSURIZED FLUID LINES



TS953

Flammable spray can be generated by heating near pressurized fluid lines, resulting in severe burns to yourself and bystanders. Do not heat by welding, soldering, or using a torch near pressurized fluid lines or other flammable materials. Pressurized lines can be accidentally cut when heat goes beyond the immediate flame area.

## USE CARE IN HANDLING AND SERVICING BATTERIES

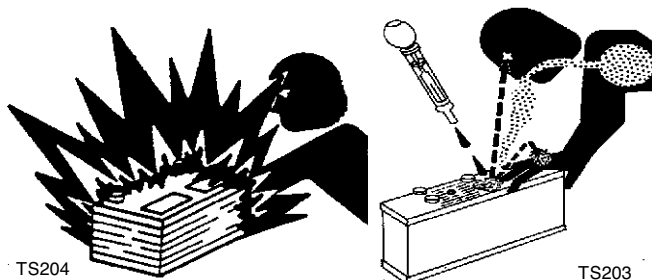

TS204

TS203

### • PREVENT BATTERY EXPLOSIONS

- Keep sparks, lighted matches, and open flame away from the top of battery. Battery gas can explode.
- Never check battery charge by placing a metal object across the posts. Use a voltmeter or hydrometer.
- Do not charge a frozen battery; it may explode. Warm battery to 16°C (60°F).

### • PREVENT ACID BURNS

- Sulfuric acid in battery electrolyte is poisonous. It is strong enough to burn skin, eat holes in clothing, and cause blindness if splashed into eyes.

### • Avoid acid burns by:

1. Filling batteries in a well-ventilated area.
2. Wearing eye protection and rubber gloves.
3. Avoiding breathing fumes when electrolyte is added.
4. Avoiding spilling or dripping electrolyte.
5. Use proper jump start procedure.

### • If you spill acid on yourself:

1. Flush your skin with water.
2. Apply baking soda or lime to help neutralize the acid.
3. Flush your eyes with water for 10\_15 minutes.
4. Get medical attention immediately.

### • If acid is swallowed:

1. Drink large amounts of water or milk.
2. Then drink milk of magnesia, beaten eggs, or vegetable oil.
3. Get medical attention immediately.



## USE SAFE SERVICE PROCEDURES

### • WEAR PROTECTIVE CLOTHING

Wear close fitting clothing and safety equipment appropriate to the job.

Prolonged exposure to loud noise can cause impairment or loss of hearing. Wear a suitable hearing protective device such as earmuffs or earplugs to protect against objectionable or uncomfortable loud noises.

Operating equipment safely requires the full attention of the operator. Do not wear radio or music headphones while operating machine.

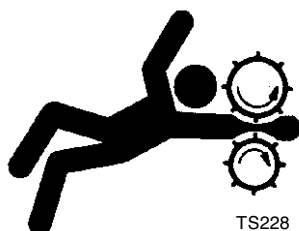
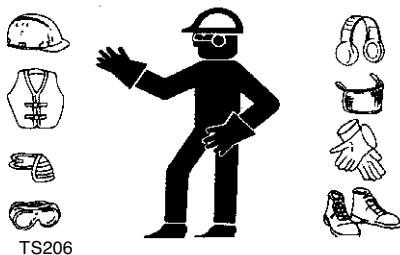

### • SERVICE MACHINES SAFELY

Tie long hair behind your head. Do not wear a necktie, scarf, loose clothing, or necklace when you work near machine tools or moving parts. If these items were to get caught, severe injury could result.

Remove rings and other jewelry to prevent electrical shorts and entanglement in moving parts.

### • USE PROPER TOOLS

Use tools appropriate to the work. Makeshift tools and procedures can create safety hazards. Use power tools only to loosen threaded parts and fasteners. For loosening and tightening hardware, use the correct size tools. **DO NOT** use U.S. measurement tools on metric fasteners. Avoid bodily injury caused by slipping wrenches. Use only service parts meeting John Deere specifications.

### • PARK MACHINE SAFELY

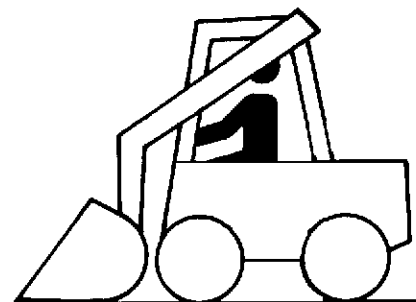

#### • Before working on the machine:

1. Lower all equipment to the ground.
2. Stop the engine and remove the key.
3. Disconnect the battery ground strap.
4. Hang a "DO NOT OPERATE" tag in operator station.

### • SUPPORT MACHINE PROPERLY AND USE PROPER LIFTING EQUIPMENT

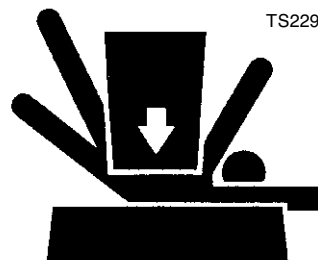

If you must work on a lifted machine or attachment, securely support the machine or attachment.

Do not support the machine on cinder blocks, hollow tiles, or props that may crumble under continuous load. Do not work under a machine that is supported solely by a jack. Follow recommended procedures in this manual.

Lifting heavy components incorrectly can cause severe injury or machine damage. Follow recommended procedure for removal and installation of components in the manual.

- **WORK IN CLEAN AREA**

- **BEFORE STARTING A JOB**

1. Clean work area and machine:
2. Make sure you have all necessary tools to do your job.
3. Have the right parts on hand.
4. Read all instructions thoroughly; do not attempt shortcuts.

- **ILLUMINATE WORK AREA SAFELY**

Illuminate your work area adequately but safely. Use a portable safety light for working inside or under the machine. Make sure the bulb is enclosed by a wire cage. The hot filament of an accidentally broken bulb can ignite spilled fuel or oil.

- **WORK IN VENTILATED AREA**

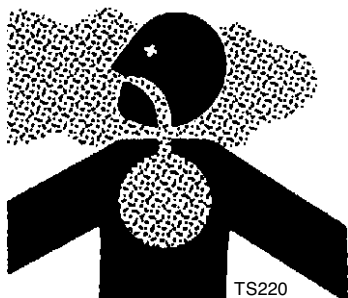

Engine exhaust fumes can cause sickness or death. If it is necessary to run an engine in an enclosed area, remove the exhaust fumes from the area with an exhaust pipe extension.

If you do not have an exhaust pipe extension, open the doors and get outside air into the area.

- **REMOVE PAINT BEFORE WELDING OR HEATING**

Avoid potentially toxic fumes and dust. Hazardous fumes can be generated when paint is heated by welding, soldering, or using a torch. Do all work outside or in a well ventilated area. Dispose of paint and solvent properly. Remove paint before welding or heating: If you sand or grind paint, avoid breathing the dust. Wear an approved respirator. If you use solvent or paint stripper, remove stripper with soap and water before welding. Remove solvent or paint stripper containers and other flammable material from area. Allow fumes to disperse at least 15 minutes before welding or heating.

- **DISCONNECT ELECTRONIC INSTRUMENT PANEL MODULE (EIPM) BEFORE WELDING OR BATTERY CHARGING**



Before welding, battery charging, or using any high voltage equipment which attaches to the Skid Steer Loader, always disconnect the Electronic Instrument Panel Module connector from the back of the electronic board. This will prevent high voltage surges which can erase the memory stored in the electronic chips of the EIPM.

- **AVOID HARMFUL ASBESTOS DUST**

Avoid breathing dust that may be generated when handling components containing asbestos fibers. Inhaled asbestos fibers may cause lung cancer.

Components in products that may contain asbestos fibers are brake pads, brake band and lining assemblies, clutch plates, and some gaskets. The asbestos used in these components is usually found in a resin or sealed in some way. Normal handling is not hazardous as long as airborne dust containing asbestos is not generated.

Avoid creating dust. Never use compressed air for cleaning. Avoid brushing or grinding material containing asbestos. When servicing, wear an approved respirator. A special vacuum cleaner is recommended to clean asbestos. If not available, apply a mist of oil or water on the material containing asbestos. Keep bystanders away from the area.

- **SERVICE TIRES SAFELY**

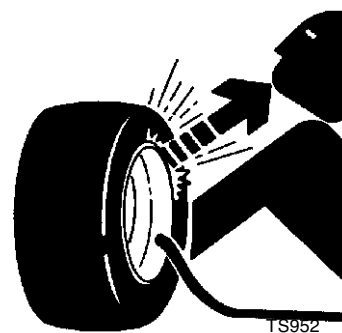

Explosive separation of a tire and rim parts can cause serious injury or death.

Do not attempt to mount a tire unless you have the proper equipment and experience to perform the job. Always maintain the correct tire pressure. Do not inflate the tires above the recommended pressure. Never weld or heat a wheel and tire assembly. The heat can cause an increase in air pressure resulting in a tire explosion. Welding can structurally weaken or deform the wheel.

When inflating tires, use a clip-on chuck and extension hose long enough to allow you to stand to one side and NOT in front of or over the tire assembly. Use a safety cage if available.

# SAFETY

---



- Check wheels for low pressure, cuts, bubbles, damaged rims or missing lug bolts and nuts.

## LIVE WITH SAFETY

TS231

### REPLACE SAFETY SIGNS

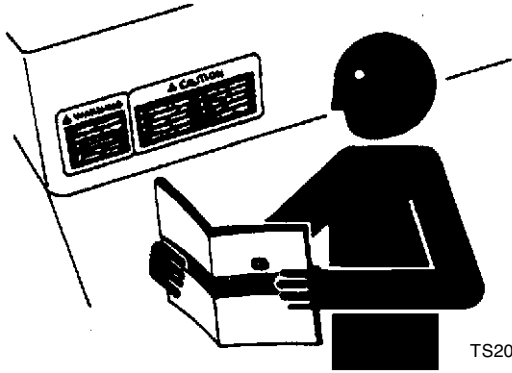

Replace missing or damaged safety signs. See the machine operator's manual for correct safety sign placement.



Before returning machine to customer, make sure machine is functioning properly, especially the safety systems. Install all guards and shields.

# CONTENTS

	Page
<b>GENERAL VEHICLE SPECIFICATIONS</b> .....	<b>2</b>
<b>UNIFIED INCH TORQUE VALUES</b> .....	<b>4</b>
<b>METRIC TORQUE VALUES</b> .....	<b>5</b>
<b>DIESEL FUEL SPECIFICATIONS</b> .....	<b>6</b>
DIESEL FUEL STORAGE .....	6
<b>LUBRICANT SPECIFICATIONS</b> .....	<b>7</b>
ENGINE OIL .....	7
GREASE .....	7
TRANSMISSION AND HYDRAULIC OIL .....	8
CHAIN CASE OIL .....	8
GEARBOX OIL .....	8
ALTERNATIVE LUBRICANTS .....	8
SYNTHETIC LUBRICANTS .....	8
OIL FILTERS .....	8
LUBRICANT STORAGE .....	8
ENGINE COOLANT .....	8
<b>SERIAL NUMBER LOCATION</b> .....	<b>10</b>
SKID STEER LOADER PRODUCT IDENTIFICATION NUMBER .....	10
ENGINE SERIAL NUMBER .....	10



**GENERAL VEHICLE SPECIFICATIONS**







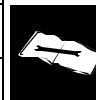





	<b>8875</b>
<b>ENGINE</b>	
Make	John Deere
Model	3029T
Type	Diesel
Cylinders	3
Bore	106.4 mm (4.19 in.)
Stroke	111.5 mm (4.39 in.)
Displacement	2.9 L (177 cu. in.)
Compression ratio	18:1
Net horsepower	45.5 kW (61)
RPM, slow (no load)	950
RPM, fast (no load)	2270
Lubrication	Force-feed; Pressurized with flow filter.
Crankcase capacity (with filter)	8.5 L (9 qt.)
Cooling system	Liquid
Coolant capacity	15.1 L (16 qt.)
Air filter type	2-Stage, replaceable paper element
<b>ELECTRICAL</b>	
Type of starter	Delco Remy 28MT
Battery voltage	12 V
Battery reserve capacity at 27°C (80° F)	160 minutes
Battery cold cranking amps at -18°C (0°F)	925 amps
Charging system	55 amp Magneton alternator
<b>FUEL SYSTEM</b>	
Fuel	Diesel # 1 or # 2
Capacity	71.2 L (18.8 gal)
Fuel delivery	Inline direct injection
Fuel shut-off	Internal Fuel shutoff solenoid in Injection Pump
<b>POWER TRAIN</b>	
Type	Hydrostatic
Charge pump	Internal gerotor type in R/H Hydrostatic pump
Hydrostatic pumps	Variable displacement axial piston

	8875
Hydrostatic pump relief pressure	34473 kPa (5000 psi)
Hydrostatic motor	Variable displacement axial piston
Charge relief pressure	2068 kPa (300 psi)
Chain case capacity (each side)	7.6 L (2 gal.)
Gearbox capacity (each gearbox)	2.8 L (3 qt.)
Brakes	Dual disks on hydrostatic motor shaft
<b>STEERING</b>	
Type	Power - hydrostatic
<b>PERFORMANCE</b>	
Manufacturers operating load	568 kg (1250 lb.)
Hydraulic lift capacity	998 kg (2200 lb.)
Ground speed (low range—high range)	12.2—19.6 km/h (7.5—12.0 mph)
Operating weight	3025 kg (6670 lb.)
<b>HYDRAULICS</b>	
Main system relief pressure	17927 kPa (2600 psi)
Circuit relief pressure	18961 kPa (2750 psi)
Hydraulic valve	3 spool open center
<b>DIMENSIONS</b>	
Length less bucket	2845 mm (112 in.)
Length with bucket	3607 mm (142 in.)
Width less bucket	1753 (69 in.)
Height to ROPS	1829 mm (72 in.)
Height to hinge pin	3099 mm (122 in.)
Dump height	2464 mm (97 in.)
Dump reach	762 mm (30 in.)
Dump angle	45°
Bucket rollback	37°
Wheelbase	1219 mm (48 in.)
Ground clearance	203 mm (8 in.)
Angle of departure	28°



UNIFIED INCH TORQUE VALUES



SAE Grade and Head Markings	1 or 2 <sup>b</sup> No Marks 	5  5.1  5.2 	8  8.2 
	2 No Marks 	5  	8  

SIZE	Grade 1				Grade 2 <sup>b</sup>				Grade 5, 5.1 or 5.2				Grade 8 or 8.2			
	Lubricated <sup>a</sup>		Dry <sup>a</sup>		Lubricated <sup>a</sup>		Dry <sup>a</sup>		Lubricated <sup>a</sup>		Dry <sup>a</sup>		Lubricated <sup>a</sup>		Dry <sup>a</sup>	
	Nm	lb-ft	Nm	lb-ft	Nm	lb-ft	Nm	lb-ft	Nm	lb-ft	Nm	lb-ft	Nm	lb-ft	Nm	lb-ft
1/4	3.7	2.8	4.7	3.5	6	4.5	7.5	5.5	9.5	7	12	9	13.5	10	17	12.5
5/16	7.7	5.5	10	7	12	9	15	11	20	15	25	18	28	21	35	26
3/8	14	10	17	13	22	16	27	20	35	26	44	33	50	36	63	46
7/16	22	16	28	20	35	26	44	32	55	41	70	52	80	58	100	75
1/2	33	25	42	31	53	39	67	50	85	63	110	80	120	90	150	115
9/16	48	36	60	45	75	56	95	70	125	90	155	115	175	130	225	160
5/8	67	50	85	62	105	78	135	100	170	125	215	160	215	160	300	225
3/4	120	87	150	110	190	140	240	175	300	225	375	280	425	310	550	400
7/8	190	140	240	175	190	140	240	175	490	360	625	450	700	500	875	650
1	290	210	360	270	290	210	360	270	725	540	925	675	1050	750	1300	975
1-1/8	470	300	510	375	470	300	510	375	900	675	1150	850	1450	1075	1850	1350
1-1/4	570	425	725	530	570	425	725	530	1300	950	1650	1200	2050	1500	2600	1950
1-3/8	750	550	950	700	750	550	950	700	1700	1250	2150	1550	2700	2000	3400	2550
1-1/2	1000	725	1250	925	990	725	1250	930	2250	1650	2850	2100	3600	2650	4550	3350

DO NOT use these values if a different torque value or tightening procedure is given for a specific application. Torque values listed are for general use only. Check tightness of fasteners periodically.

Shear bolts are designed to fail under predetermined loads. Always replace shear bolts with identical grade.

Fasteners should be replaced with the same or higher grade. If higher grade fasteners are used, these should only be tightened to the strength of the original. Make sure fasteners threads are clean and that you properly start thread engagement. This will prevent them from failing when tightening. Tighten plastic insert or crimped steel-type lock nuts to approximately 50 percent of the dry torque shown in the chart, applied to the nut, not to the bolt head.

Tighten toothed or serrated-type lock nuts to the full torque value.

<sup>a</sup> "Lubricated" means coated with a lubricant such as engine oil, or fasteners with phosphate and oil coatings. "Dry" means plain or zinc plated without any lubrication<sup>b</sup>

<sup>b</sup> Grade 2 applies for hex cap screws (not hex bolts) up to 152 mm (6-in.) long. Grade 1 applies for hex cap screws over 152 mm (6-in.) long, and for all other types of bolts and screws of any length.

METRIC TORQUE VALUES

Property Class and Head Markings	4.8		8.8		9.8		10.9		12.9	
Property Class and Nut Markings	5		10		10		10		12	



SIZE	Class 4.8		Class 8.8 or 9.8				Class 10.9				Class 12.9					
	Lubricated <sup>a</sup>		Dry <sup>a</sup>		Lubricated <sup>a</sup>		Dry <sup>a</sup>		Lubricated <sup>a</sup>		Dry <sup>a</sup>		Lubricated <sup>a</sup>		Dry <sup>a</sup>	
	Nm	lb-ft	Nm	lb-ft	Nm	lb-ft	Nm	lb-ft	Nm	lb-ft	Nm	lb-ft	Nm	lb-ft	Nm	lb-ft
M6	48	3.5	6	4.5	9	6.5	11	8.5	13	9.5	17	12	15	11.5	19	14.5
M8	12	8.5	15	11	22	16	28	20	32	24	40	30	37	28	47	35
M10	23	17	29	21	43	32	55	40	63	47	80	60	75	55	95	70
M12	40	29	50	37	75	55	95	70	110	80	140	105	130	95	165	120
M14	63	47	80	60	120	88	150	110	175	130	225	165	205	150	260	109
M16	100	73	125	92	190	140	240	175	275	200	350	225	320	240	400	300
M18	135	100	175	125	260	195	330	250	375	275	475	350	440	325	560	410
M20	190	140	240	180	375	275	475	350	530	400	675	500	625	460	800	580
M22	260	190	330	250	510	375	650	475	725	540	925	675	850	625	1075	800
M24	330	250	425	310	650	475	825	600	925	675	1150	850	1075	800	1350	1000
M27	490	360	625	450	950	700	1200	875	1350	1000	1700	1250	1600	1150	2000	1500
M30	675	490	850	625	1300	950	1650	1200	1850	1350	2300	1700	2150	1600	2700	2000
M33	900	675	1150	850	1750	1300	2200	1650	2500	1850	3150	2350	2900	2150	3700	2750
M36	1150	850	1450	1075	2250	1650	2850	2100	3200	2350	4050	3000	3750	2750	4750	3500

DO NOT use these values if a different torque value or tightening procedure is given for a specific application. Torque values listed are for general use only. Check tightness of fasteners periodically.

Shear bolts are designed to fail under predetermined loads. Always replace shear bolts with identical grade.

Fasteners should be replaced with the same or higher grade. If higher grade fasteners are used, these should only be tightened to the strength of the original. Make sure fasteners threads are clean and that you properly start thread engagement. This will prevent them from failing when tightening.

Tighten plastic insert or crimped steel-type lock nuts to approximately 50 percent of the dry torque shown in the chart, applied to the nut, not to the bolt head. Tighten toothed or serrated-type lock nuts to the full torque value.

<sup>a</sup> "Lubricated" means coated with a lubricant such as engine oil, or fasteners with phosphate and oil coatings. "Dry" means plain or zinc plated without any lubrication.

<sup>b</sup> Grade 2 applies for hex cap screws (not hex bolts) up to 152 mm (6-in.) long. Grade 1 applies for hex cap screws over 152 mm (6-in.) long, and for all other types of bolts and screws of any length.

**DIESEL FUEL SPECIFICATIONS**

Use only clean, high quality fuel.

Use Grade No. 2-D fuel at temperatures above 4°C (40°F).



Use Grade No. 1-D fuel at temperatures below 4°C (40°F).

Use Grade No. 1-D fuel for all air temperatures at altitudes above 1500 m (5000 ft).

**IMPORTANT: Use fuel with less than 1.0 per cent sulfur. If possible, use fuel with less than 0.5 per cent sulfur. If fuel sulfur is more than 0.5 per cent, change engine oil and filter every 100 hours.**

For maximum filter life, sediment and water should not be more than 0.10 per cent.

The octane number should be 40 minimum. If you operate your tractor where air temperatures are normally low or where altitudes are high, you may need fuel with a higher cetane number.

Cloud Point - For cold weather operation, cloud point should be 10°F (6°C) below lowest normal air temperature.

**Fuel Tank Capacity**

8875 . . . . . 71.2 L (18.8 gal)

**DIESEL FUEL STORAGE**

NOTE: Diesel fuels stored for a long time may form gum and plug filters.

Keep fuel in a clean container in a protected area. Water and sediment must be removed before fuel gets to the engine. Do not use de-icers to remove water from fuel. Do not depend on fuel filters to remove water. If possible, install a water separator at the storage tank outlet. (See your John Deere dealer for this part.)

**IMPORTANT: Keep all dirt, scale, water or other foreign material out of fuel.**

Store fuel drum on its side with plug up.

**DO NOT STORE DIESEL FUEL IN GALVANIZED CONTAINERS**

**IMPORTANT: Diesel fuel stored in galvanized containers reacts with the zinc coating of the container to form zinc flakes. If fuel contains any water, a zinc gel will also form. The gel and flakes will quickly plug fuel filters and may damage fuel injectors and fuel pumps.**

Store diesel fuel in:

- plastic containers
- aluminum containers
- specially coated steel containers made for diesel fuel.

**DO NOT USE BRASS-COATED CONTAINERS:** brass is an alloy of copper and zinc.

LUBRICANT SPECIFICATIONS

ENGINE OIL

Use oil viscosity based on the expected air temperature range during the period between oil changes.

The following oil is preferred:

- John Deere TORQ-GARD SUPREME PLUS-50™

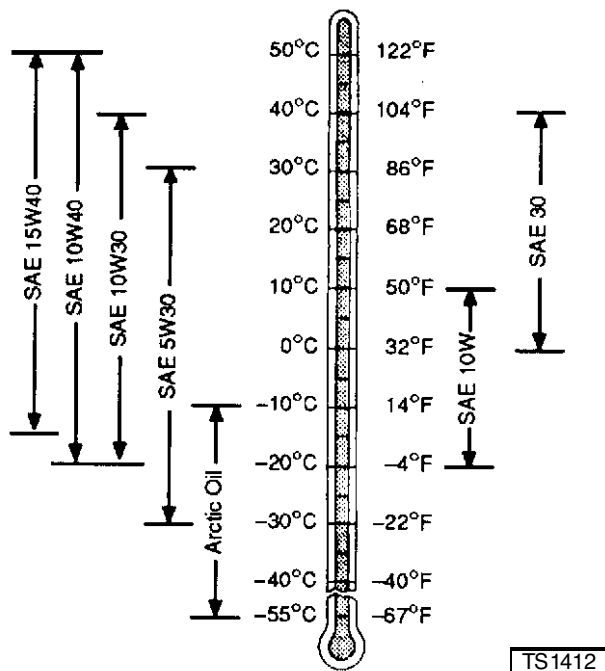

The following oils are also recommended:

- John Deere TORQ-GARD SUPREME®
- John Deere UNI-GARD™

Other oils may be used if they meet one of the following:

- API Service Classification CE
- API Service Classification CD
- CCMC Specification D5
- CCMC Specification D4
- Oils meeting Military Specification MIL-L-46167B may be used as arctic oils.

If John Deere TORQ-GARD SUPREME PLUS-50™ engine oil and a John Deere oil filter are used, the oil and filter service interval may be extended by 50 hours.

If diesel fuel exceeding 0.5% sulphur content is used, reduce the service interval for engine oil and filter by 50%.

GREASE

Use grease based on the expected air temperature range during the service interval.

The following greases are preferred:

- John Deere MOLY HIGH TEMPERATURE EP GREASE
- John Deere HIGH TEMPERATURE EP GREASE
- John Deere GREASE-GARD™

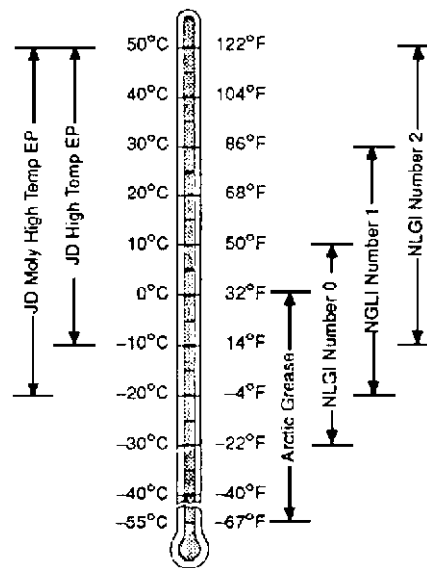

Other greases may be used if they meet one of the following:

- SAE Multipurpose EP Grease with a maximum of 5% molybdenum disulfide.
  - SAE Multipurpose EP Grease
- Greases meeting Military Specification MIL-G-10924F may be used as arctic grease.

## TRANSMISSION AND HYDRAULIC OIL

The following oil is preferred:

- John Deere PLUS-4 ® 10W-30

When adding small amounts of oil to top off the oil reservoir, the following oil in descending order is permissible:

- John Deere TURF-GARD ®
- 10W-30 oil equivalent to John Deere PLUS-4 ®
- John Deere HY-GARD ®

## CHAIN CASE OIL

The following oil is preferred:

- John Deere PLUS-4 ® 10W-30

When adding small amounts of oil to top off the oil reservoir, the following oil in descending order is permissible:

- John Deere TURF-GARD ®
- 10W-30 oil equivalent to John Deere PLUS-4 ®
- John Deere HY-GARD ®

## GEARBOX OIL

Use oil viscosity based on the expected air temperature range during the period between oil changes.

John Deere GL-5 Gear Lubricant is recommended.

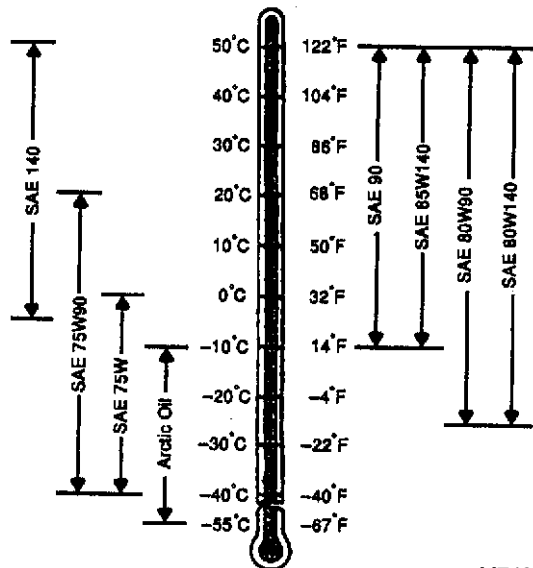

M74991

Other oils may be used if they meet one or more of the following:

- API Service Classification GL-5.
- Military Specification MIL-L-2105D.
- Military Specification MIL-L-2105C.

- Military Specification MIL-L-2105B.

Oils meeting Military Specification MIL-L-10324A may be used as arctic oils.

## ALTERNATIVE LUBRICANTS

Conditions in certain geographical areas outside the United States and Canada may require different lubricant recommendations than those printed in this manual or the operator's manual. Consult with your John Deere Dealer, or Sales Branch to obtain the alternative lubricant recommendations.

## SYNTHETIC LUBRICANTS

Synthetic lubricants may be used in John Deere equipment if they meet the applicable performance requirements (industry classification and/or military specification) as shown in this group.

The recommended temperature limits and service or oil change intervals should be maintained as shown in the operator's manual.

Avoid mixing different brands, grades, or types of oil. Oil manufacturers blend additive in their oils to meet certain specifications and performance requirements. Mixing different oils can interfere with the proper functioning of these additives and degrade lubricant performance.

## OIL FILTERS

Filtration of oils is critical to proper lubrication. Always change filters regularly.

Use filters meeting John Deere performance specification.

## LUBRICANT STORAGE

This machine can operate at top efficiency only if clean lubricants are used.

Use clean containers to handle all lubricants. Store them in an area protected from dust, moisture, and other contamination. Store drums on their sides.

## ENGINE COOLANT

To meet cooling system protection requirements, the coolant MUST consist of a 50/50 mixture of quality water and ethylene glycol concentrate (antifreeze). Add to the mixture 3% (by volume) supplemental coolant additives (SCA's). See ENGINE COOLANT SPECIFICATIONS, later in this group, for further definition.

Makeup of the coolant between changes MUST consist of the same requirements as during a complete change. Performing a COOLSCAN analysis is the recommended method for determining the amount of

quality water, ethylene glycol concentrate, and supplemental coolant additives that should be added.

**IMPORTANT: Supplemental coolant additives MUST be added to the coolant solution. Ethylene glycol concentrate (antifreeze) DOES NOT contain chemical inhibitors needed to control liner pitting or erosion, rust, scale, and acidity.**

Coolant solutions of ethylene glycol concentrate (antifreeze), quality water, and supplemental coolant additives (SCA's) MUST be used year-round to protect against freezing, boil-over, liner erosion or pitting, and to provide a stable, non-corrosive environment for seals, hoses, and metal engine parts.

Water pump impellers and cylinder liner walls which are in contact with engine coolant can be eroded or pitted unless the proper concentration and type of SCA's are present in the coolant solution.

Generally, the most critical erosion occurs in the cylinder liner area of wet-sleeve, heavy-duty diesel engines. If coolant is allowed to enter the combustion chamber, engine failure or other serious damage will result.

Use of SCA's will reduce the effects of erosion and pitting. The chemicals in the additives form a protective film on cylinder liner surface. This film acts as a barrier against harmful erosion and pitting.

#### WATER QUALITY:

Distilled, de-ionized, or soft water is preferred for use in cooling systems. Mineral (hard/tap) water should NEVER be put in a cooling system unless first tested.

#### ETHYLENE GLYCOL CONCENTRATE (ANTIFREEZE):

**IMPORTANT: DO NOT use methyl alcohol or methoxy propanol base concentrate. This concentrate is not compatible with additives used in supplemental coolant additives. Damage can occur to rubber seals on cylinder liners which are in contact with coolant.**

**DO NOT use ethylene glycol concentrate containing sealer or stop-leak additives.**

**DO NOT use concentrate containing less than 10% ethylene glycol.**

**DO NOT use concentrate containing more than 0.1% anhydrous metasilicate. This type of concentrate, which is intended for use in aluminum engines, may cause a gel-like deposit to form that reduces heat transfer and coolant flow. Check container label or consult with supplier before using.**

John Deere Low Silicate Antifreeze is the ethylene glycol concentrate recommended for all John Deere Diesel Engines. This product is concentrated and should be mixed 50/50 with quality water. Add to the mixture 3% (by volume) supplemental coolant additives (SCA's).

#### SUPPLEMENTAL COOLANT ADDITIVES (SCA's):

**IMPORTANT: Ethylene glycol concentrate DOES NOT contain sufficient additives to prevent liner erosion or pitting which could occur in wet sleeve diesel engines. ALWAYS mix the coolant solution with a supplemental coolant additive such as John Deere Liquid Coolant Conditioner or spin-on coolant filter conditioner element.**



## C CAUTION:

**John Deere Liquid coolant Conditioner contains alkali. Avoid contact with eyes. Avoid prolonged or repeated contact with skin. Do not take internally. In case of contact, immediately wash skin with soap and water. For eyes, flush with large amounts of water for at least 15 minutes. Call physician. KEEP OUT OF REACH OF CHILDREN.**

- John Deere Liquid Coolant Conditioner

**IMPORTANT: ALWAYS mix the 50/50 solution of ethylene glycol concentrate with quality water in a separate container BEFORE adding the SCA's. Then add solution to the radiator. NEVER pour cold water into a hot engine, as it may crack cylinder block or head.**

John Deere Liquid Coolant Conditioner MUST be added at a rate of 3% (by volume) to the coolant solution. When adding John Deere Liquid Coolant Conditioner, follow the supplier's recommendations printed on the container.

**IMPORTANT: John Deere Liquid Coolant Conditioner does NOT protect against freezing. DO NOT over-concentrate coolant solutions with supplemental coolant additives, as this can cause silicate-dropout. When this happens, a gel-type deposit is created which retards heat transfer and coolant flow. DO NOT use soluble oil.**

**DISPOSING OF COOLANT:**

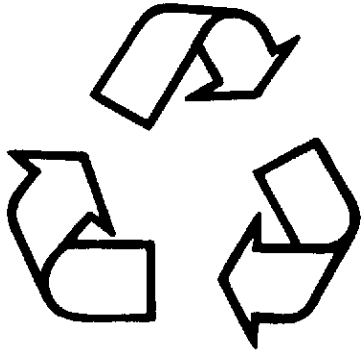

Improperly disposing of engine coolant can threaten the environment and ecology.

Use leakproof containers when draining fluids. Do not use food or beverage containers that may mislead someone into drinking from them.

Do not pour waste onto the ground, down a drain, or into any water source.

Inquire on the proper way to recycle or dispose of waste from your local environmental or recycling center, or from your John Deere dealer.

**SERIAL NUMBER LOCATION**

When ordering parts or submitting a warranty claim, it is **IMPORTANT** that you include the skid steer loader product identification number and the component serial numbers.

The location of skid steer loader product identification number and component serial numbers are shown.

**SKID STEER LOADER PRODUCT IDENTIFICATION NUMBER**



**ENGINE SERIAL NUMBER**

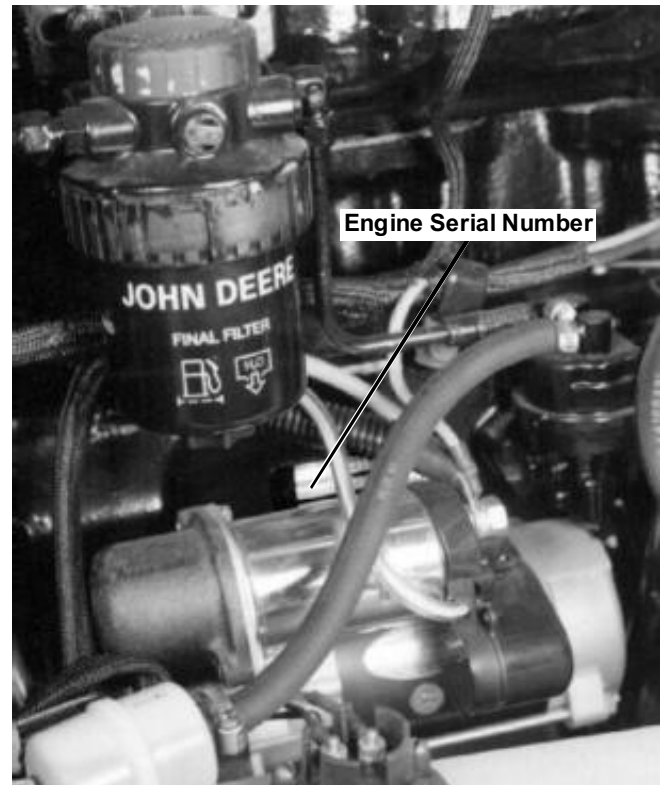

# CONTENTS

	Page
<b>SPECIFICATIONS</b> .....	<b>7</b>
GENERAL SPECIFICATIONS: .....	7
REPAIR SPECIFICATIONS: .....	7
SEALANT APPLICATION GUIDELINES .....	13
LUBRICATION SYSTEM OPERATION .....	14
<b>THEORY OF OPERATION</b> .....	<b>15</b>
FUEL SYSTEM OPERATION .....	15
<b>DIAGNOSIS</b> .....	<b>16</b>
DIAGNOSING ENGINE MALFUNCTIONS .....	16
CYLINDER LINER, PISTON, AND CONNECTING ROD DIAGNOSIS .....	18
CYLINDER HEAD AND VALVE DIAGNOSIS .....	19
CRANKSHAFT DIAGNOSIS .....	20
FUEL SYSTEM DIAGNOSIS .....	21
FUEL SUPPLY PUMP DIAGNOSIS .....	22
FUEL INJECTION NOZZLE DIAGNOSIS .....	23
FUEL INJECTION NOZZLE DIAGNOSIS .....	24
FUEL INJECTION PUMP DIAGNOSIS .....	25
AIR INTAKE SYSTEM DIAGNOSIS .....	25
<b>TESTS AND ADJUSTMENTS</b> .....	<b>26</b>
VALVE ADJUSTMENT .....	26
VALVE LIFT MEASUREMENT .....	26
PRELIMINARY ENGINE TESTING .....	27
ENGINE COMPRESSION PRESSURE TESTING .....	27
ENGINE OIL PRESSURE TEST .....	28
INTAKE MANIFOLD PRESSURE (TURBO BOOST) TEST .....	28
CRANKCASE VENTILATION SYSTEM INSPECTION .....	28
AIR INTAKE SYSTEM INSPECTION .....	29
CHECK EXHAUST SYSTEM .....	29
COOLING SYSTEM & RADIATOR CAP PRESSURE TEST .....	29
FUEL DRAIN BACK TEST .....	29
<b>REPAIR</b> .....	<b>29</b>
CLEAN ENGINE .....	29
ENGINE REMOVAL (CAB TILTED) .....	29
ENGINE LIFTING PROCEDURE .....	30
ENGINE REPAIR STAND .....	30
ENGINE DISASSEMBLY SEQUENCE .....	32
ENGINE ASSEMBLY SEQUENCE .....	32
<b>CYLINDER HEAD REPAIR</b> .....	<b>33</b>
CYLINDER HEAD REMOVAL .....	33
ROCKER ARM DISASSEMBLY & INSPECTION .....	34
ROCKER ARM ASSEMBLY .....	34
CAMSHAFT FOLLOWER REMOVAL & INSPECTION .....	35





	Page
VALVE RECESS CHECK .....	36
VALVE ASSEMBLY REMOVAL .....	36
VALVE SPRING INSPECTION .....	36
VALVE ROTATOR INSPECTION .....	37
VALVE CLEANING .....	37
VALVE INSPECTION .....	37
VALVE GRIND .....	38
CYLINDER HEAD INSPECTION .....	38
CYLINDER HEAD FLATNESS .....	38
CYLINDER HEAD THICKNESS .....	38
INJECTOR BORE CLEANING .....	39
VALVE GUIDE CLEANING .....	39
VALVE GUIDE MEASUREMENT .....	39
VALVE GUIDE KNURLING .....	40
VALVE SEAT CLEANING AND INSPECTION .....	40
VALVE SEAT GRINDING .....	40
VALVE SEAT REPAIR .....	41
VALVE INSTALLATION .....	42
CYLINDER HEAD BOLT INSPECTION .....	42
EXHAUST MANIFOLD INSPECTION & CLEANING .....	42
CYLINDER BLOCK TOP DECK CLEANING & INSPECTION .....	42
CYLINDER HEAD INSTALLATION .....	43
TORQUE-TURN METHOD FOR PROPER TORQUE .....	43
ROCKER ARM INSTALLATION .....	44
ROCKER ARM COVER VENT CLEANING AND INSPECTION .....	45
ROCKER ARM COVER INSTALLATION .....	45
COMPLETE FINAL ASSEMBLY .....	45
<b>CYLINDER BLOCK REPAIR .....</b>	<b>46</b>
PISTON AND CONNECTING ROD REMOVAL .....	46
CYLINDER LINER HEIGHT MEASUREMENT .....	47
CYLINDER LINER REMOVAL .....	48
PISTON ROD REMOVAL .....	49
PISTON CLEANING .....	49
PISTON INSPECTION .....	49
CYLINDER LINER CLEANING .....	50
CYLINDER LINER INSPECTION .....	50
PISTON AND CYLINDER LINER MEASUREMENT .....	51
CYLINDER LINER DEGAZING .....	53
PISTON AND LINER REPLACEMENT .....	53
CONNECTING ROD BEARING INSPECTION & MEASUREMENT .....	53
CONNECTING ROD AND CAP INSPECTION .....	54
PISTON PIN AND ROD BUSHING INSPECTION .....	54
PISTON PIN BUSHING REMOVAL .....	55
CONNECTING ROD PIN BORE CLEANING & INSPECTION .....	55

	Page
PISTON PIN BUSHING INSTALLATION . . . . .	55
CYLINDER BLOCK CLEANING & INSPECTION . . . . .	55
CYLINDER LINER O-RING BORE CLEANING . . . . .	56
CYLINDER BLOCK MAIN BEARING BORE MEASUREMENT . . . . .	56
CAMSHAFT FOLLOWER BORE MEASUREMENT . . . . .	56
CAMSHAFT BEARING BORE MEASUREMENT . . . . .	57
CYLINDER BLOCK FLATNESS MEASUREMENT . . . . .	57
PISTON COOLING ORIFICE INSPECTION . . . . .	58
CYLINDER LINER FLANGE THICKNESS MEASUREMENT . . . . .	58
CYLINDER LINER HEIGHT MEASUREMENT . . . . .	58
CYLINDER LINER O-RING & PACKING INSTALLATION . . . . .	59
CYLINDER LINER INSTALLATION . . . . .	60
PISTON & CONNECTING ROD ASSEMBLY . . . . .	60
PISTON RING INSTALLATION . . . . .	60
PISTON & CONNECTING ROD ASSEMBLY INSTALLATION . . . . .	61
CRANKSHAFT ROTATION TORQUE . . . . .	62
PISTON PROTRUSION MEASUREMENT . . . . .	62
COMPLETE FINAL ASSEMBLY . . . . .	63
ENGINE BREAK-IN PROCEDURE . . . . .	63
<b>CRANKSHAFT, MAIN BEARINGS, AND FLYWHEEL REPAIR . . . . .</b>	<b>63</b>
CRANKSHAFT PULLEY REMOVAL . . . . .	63
CRANKSHAFT PULLEY INSTALLATION . . . . .	64
FLYWHEEL HOUSING REMOVAL . . . . .	64
HYDROSTATIC PUMP DRIVE SHAFT SEAL REPAIR . . . . .	65
CRANKSHAFT END PLAY CHECK . . . . .	65
FLYWHEEL REMOVAL . . . . .	65
FLYWHEEL INSPECTION . . . . .	66
FLYWHEEL RING GEAR REPLACEMENT . . . . .	66
FLYWHEEL PILOT BEARING REPLACEMENT . . . . .	66
FLYWHEEL INSTALLATION . . . . .	67
CRANKSHAFT REAR OIL SEAL REMOVAL . . . . .	68
CRANKSHAFT REAR OIL SEAL INSTALLATION . . . . .	68
ENGINE REAR PLATE REMOVAL . . . . .	69
REMOVE MAIN BEARINGS . . . . .	70
CRANKSHAFT MAIN BEARING CLEARANCE CHECK (IN BLOCK) . . . . .	70
CRANKSHAFT REMOVAL . . . . .	71
CRANKSHAFT GEAR REMOVAL . . . . .	71
CRANKSHAFT INSPECTION . . . . .	71
CRANKSHAFT MAIN BEARING MEASUREMENT . . . . .	71
CRANKSHAFT THRUST BEARING & JOURNAL MEASUREMENT . . . . .	72
CRANKSHAFT GRINDING GUIDELINES . . . . .	73
CRANKSHAFT MAIN BEARING CAP MEASUREMENT . . . . .	73
CRANKSHAFT GEAR INSTALLATION . . . . .	74
PISTON COOLING ORIFICES INSPECTION . . . . .	74



	Page
MAIN BEARING AND CRANKSHAFT INSTALLATION . . . . .	75
ENGINE REAR PLATE INSTALLATION . . . . .	76
FLYWHEEL HOUSING INSTALLATION . . . . .	76
HYDROSTATIC PUMP DRIVE SHAFT INSTALLATION . . . . .	77
COMPLETE FINAL ASSEMBLY . . . . .	77
<b>CAMSHAFT AND TIMING GEAR REPAIR . . . . .</b>	<b>78</b>
VALVE LIFT MEASUREMENT . . . . .	78
TIMING GEAR COVER REMOVAL . . . . .	78
CAMSHAFT END PLAY MEASUREMENT . . . . .	79
IDLER GEAR END PLAY MEASUREMENT . . . . .	79
TIMING GEAR BACKLASH MEASUREMENT . . . . .	79
CAMSHAFT REMOVAL . . . . .	80
CAMSHAFT INSPECTION . . . . .	80
CAMSHAFT THRUST PLATE CLEARANCE . . . . .	81
CAMSHAFT BEARING MEASUREMENT . . . . .	81
CAMSHAFT LOBE MEASUREMENT . . . . .	81
CAMSHAFT GEAR REPLACEMENT . . . . .	82
CAMSHAFT FOLLOWER INSPECTION . . . . .	82
CAMSHAFT BUSHING REPLACEMENT . . . . .	82
FRONT PLATE REMOVAL . . . . .	83
MEASURE IDLER GEAR BUSHING AND SHAFT . . . . .	84
IDLER GEAR BUSHING REPLACEMENT . . . . .	85
IDLER GEAR SHAFT REMOVAL . . . . .	85
ENGINE FRONT PLATE REPLACEMENT . . . . .	85
IDLER SHAFT INSTALLATION . . . . .	86
INSTALL ENGINE FRONT PLATE . . . . .	86
FUEL INJECTION PUMP INSTALLATION . . . . .	87
CAMSHAFT INSTALLATION . . . . .	87
IDLER GEAR INSTALLATION . . . . .	88
TIMING GEAR COVER CLEANING AND INSPECTION . . . . .	88
TIMING GEAR COVER INSTALLATION . . . . .	88
CRANKSHAFT FRONT OIL SEAL INSTALLATION . . . . .	88
FINAL ASSEMBLY . . . . .	89
<b>LUBRICATION SYSTEM . . . . .</b>	<b>89</b>
OIL COOLER REPAIR . . . . .	89
OIL PRESSURE REGULATING VALVE & SEAT REPAIR . . . . .	90
OIL FILTER NIPPLE REPAIR . . . . .	90
DIPSTICK REPAIR . . . . .	91
OIL PUMP REPAIR . . . . .	91
OIL PAN INSTALLATION . . . . .	94
OIL PAN DRAIN PLUG . . . . .	95
<b>COOLING SYSTEM . . . . .</b>	<b>95</b>
COOLING SYSTEM TESTING . . . . .	95



	Page
THERMOSTAT REMOVAL & TESTING .....	95
WATER MANIFOLD REMOVAL & INSTALLATION .....	96
WATER PUMP REPAIR.....	96
WATER PUMP REMOVAL .....	97
WATER PUMP DISASSEMBLY.....	97
WATER PUMP CLEANING & INSPECTION .....	97
WATER PUMP ASSEMBLY.....	98
WATER PUMP INSTALLATION .....	99
FAN BLADE INSPECTION AND INSTALLATION .....	99
<b>TURBOCHARGER DIAGNOSIS.....</b>	<b>100</b>
TURBOCHARGER DIAGNOSIS (Cont.) .....	101
TURBOCHARGER DIAGNOSIS (Cont.) .....	102
TURBOCHARGER REMOVAL .....	103
TURBOCHARGER FAILURE ANALYSIS .....	103
TURBOCHARGER BEARING RADIAL CLEARANCE TEST .....	106
TURBOCHARGER BEARING AXIAL END PLAY TEST .....	107
<b>TURBOCHARGER REPAIR.....</b>	<b>107</b>
TURBOCHARGER DISASSEMBLY AND INSPECTION.....	107
TURBOCHARGER CENTER HOUSING & ROTATING ASSEMBLY REPLACEMENT.....	108
TURBOCHARGER PRE-LUBRICATION.....	108
INSTALL TURBOCHARGER.....	108
TURBOCHARGER BREAK-IN.....	109
<b>INTAKE MANIFOLD REPAIR.....</b>	<b>109</b>
<b>EXHAUST MANIFOLD REPAIR.....</b>	<b>110</b>
<b>FUEL SYSTEM .....</b>	<b>110</b>
RELIEVE FUEL SYSTEM PRESSURE .....	110
FUEL FILTER REPLACEMENT.....	110
FUEL PUMP REMOVAL .....	111
FUEL PUMP TESTING .....	111
FUEL PUMP INSTALLATION .....	112
FUEL INJECTION PUMP TIMING MARK .....	112
FUEL INJECTION PUMP TIMING .....	113
INJECTION PUMP REMOVAL .....	113
INJECTION PUMP DRIVE GEAR & SHAFT INSPECTION.....	114
FUEL INJECTION PUMP REPAIR .....	114
FUEL INJECTION PUMP INSTALLATION .....	114
FUEL INJECTION NOZZLE REMOVAL .....	116
FUEL INJECTION NOZZLE BORE CLEANING .....	117
INJECTION NOZZLE CLEANING .....	117
FUEL INJECTION NOZZLE TESTS .....	118
FUEL INJECTION NOZZLE DISASSEMBLY.....	119





	<b>Page</b>
FUEL INJECTION NOZZLE CLEANING & INSPECTION . . . . .	120
FUEL INJECTION NOZZLE VALVE SEAT INSPECTION & CLEANING . . . . .	120
FUEL INJECTION NOZZLE VALVE ADJUSTOR INSPECTION . . . . .	121
FUEL INJECTION NOZZLE ASSEMBLY . . . . .	121
FUEL INJECTION NOZZLE ADJUSTMENT . . . . .	121
FUEL INJECTION NOZZLE SEAL INSTALLATION . . . . .	123
FUEL INJECTION NOZZLE INSTALLATION . . . . .	123
ALTITUDE COMPENSATION GUIDELINES . . . . .	124

## SPECIFICATIONS

### GENERAL SPECIFICATIONS :

Make .....	John Deere Series 300 (Saran )
Model .....	CD 3029T
Number Of Cylinders .....	3
Cylinder Firing Order: .....	1-2-3
Bore.....	106.5 mm (4.19 in.)
Stroke .....	110 mm (4.33 in.)
Displacement .....	2.9 L (179 cu in.)
Compression Ratio .....	17.8:1
Firing Order .....	1-2-3
Piston Speed .....	549.8 m/min (1804 ft/min)
Rated Speed .....	2500 RPM
Idle Speed .....	800-850



#### Bearings:

Number Of Mains .....	4
Main Diameter .....	79.2 mm (3.12 in.)
Main Width .....	28.4 mm (1.12 in.)
Rod Journal Diameter .....	69.8 mm (2.75 in.)
Rod Journal Width.....	30.0 mm (1.18 in.)

#### Lubrication System:

Pump Capacity .....	0.88 L/s (14 gpm)
Normal Oil Pressure At Rated Speed, 30 W Oil At 105° C (220° F) . . .	380 kPa (55 psi)
Minimum Oil Pressure At Idle Speed .....	138 kPa (20 psi)
Bypass Pressure Relief In Oil Filter .....	155 kPa (22 psi)

### REPAIR SPECIFICATIONS :

#### Cylinder Head

Thickness of New Cylinder Head .....	104.87-105.13 mm (4.129-4.139 in.)
Wear Limit .....	104.25 mm (4.104 in.)
Maximum Material Removal for Resurfacing Head .....	0.76mm (0.030 in.)
Maximum Acceptable Head Out-of Flat :	
For Entire Length of Width .....	0.08 mm (0.003 in.)
For Every 150 mm (5.90 in.) Length or Width .....	0.03 mm (0.001 in.)
Combustion Face Surface Finish	
(Surface Grind Only) (AA) .....	0.0008-0.0032 mm (31-125 micro-in.)
Maximum Wave Depth .....	0.012 mm (0.0005 in.)

#### Valves

Standard Valve Stem OD :	
Intake Valve .....	7.864-7.884 mm (0.3096-0.3104 in.)
Exhaust Valve .....	7.848-7.874 mm (0.3090-0.3100 in.)
Oversize Valve Stems Available .....	0.38 mm (0.015 in.) and 0.76 mm (0.030 in.)
Valve Guide ID .....	7.912-7.938 mm (0.312-0.313 in.)
Valve Stem-to-Guide Clearance .....	0.05-0.10 mm (0.002-0.004 in.)
Wear Limit .....	0.15 mm (0.006 in.)
Valve Seat Angle (intake and exhaust) .....	30°
Valve Face Angle (intake and exhaust) .....	29.25° ± 0.25°



Maximum Valve Seat Runout .....	0.08 mm (0.003 in.)
Maximum Valve Face Runout (Intake and Exhaust) .....	0.038 mm (0.0015 in.)
Valve Recess in Cylinder Head:	
Intake Valve .....	0.61-1.11 mm (0.024-0.044 in.)
Wear Limit .....	1.63 mm (0.064 in.)
Exhaust Valve .....	1.22-1.72 mm (0.048-0.068 in.)
Wear Limit .....	2.26 mm (0.089 in.)
Valve Seat Width (Intake And Exhaust) .....	1.50-2.00 mm (0.059-0.079 in.)
Valve Head OD:	
Intake Valve .....	46.47-46.73 mm (1.830-1.840 in.)
Exhaust Valve .....	42.37-42.63 mm (1.668-1.678 in.)
Cylinder Firing Order: .....	
1-2-3	
Valve Clearance (Rocker Arm-To-Valve Tip) :	
Intake Valve .....	0.35 mm (0.014 in.)
Exhaust Valve .....	0.45 mm (0.018 in.)
Valve Lift At 0.00 mm (in.) Clearance :	
Intake Valve .....	11.56-12.37 mm (0.455-0.487 in.)
Wear Limit .....	11.13 mm (0.438 in.)
Exhaust Valve .....	11.28-12.12 mm (0.444-0.477 in.)
Wear Limit .....	10.85 mm (0.427 in.)
Rocker Arm Shaft OD .....	19.99-20.02 mm (0.787-0.788 in.)
Wear Limit .....	19.94 mm (0.785 in.)
Rocker Arm Bore ID .....	20.07-20.12 mm (0.790-0.792 in.)
Wear Limit .....	20.17 mm (0.794 in.)
Rocker Arm Shaft Spring	
Compressed Height .....	46 mm @ 18-27 N (1.81 in. @ 4-6 lb-force)
Valve Spring Compressed Height:	
Valve Closed .....	46 mm @ 240-280 N (1.81 in. @ 54-62 lb-force)
Valve Open .....	34.5 mm @ 590-680 N (1.36 in. @ 133-153 lb-force)
Liner Height Above Block .....	0.030-0.100 mm (0.0010-0.0040 in.)
Maximum Permissible Height Difference	
At Nearest Point Of Two Adjacent Liners .....	0.051 mm (0.0020 in.)
Cam Follower OD .....	31.61-31.64 mm (1.245-1.246 in.)

**Cylinder Block:**

Main Bearing Bore in Cylinder Block .....	84.46-84.48 mm (3.325-3.326 in.)
Main Bearing Centerline to Top Deck of Block ..	302.00-302.08 mm (11.890-11.893 in.)
Wear Limit .....	301.98 mm (11.889 in.)
Maximum Acceptable Top Deck Out-of Flat :	
For Entire Length of Width .....	0.08 mm (0.003 in.)
For Every 150 mm (5.90 in.) Length or Width .....	0.025 mm (0.001 in.)
Top Deck Surface Finish	
(Surface Grind Only) (AA) .....	0.0008-0.0032 mm (31-125 micro-in.)
Maximum Wave Depth .....	0.012 mm (0.0005 in.)
Cylinder Block Upper Counterbore Depth .....	5.95-5.99 mm (0.234-0.236 in.)
Camshaft Follower Bore ID .....	31.70-31.75 mm (1.248-1.250 in.)
Camshaft Follower Bore OD .....	31.61-31.64 mm (1.245-1.246 in.)
Camshaft Follower Clearance .....	0.06-0.13 mm (0.002-0.005 in.)
Camshaft Bore (Except No. 1) .....	55.986-56.012 mm (2.2042-2.2052 in.)
Camshaft Bore (No. 1 camshaft bore) .....	59.961-59.987 mm (2.3607-2.3617 in.)
No. 1 Camshaft Bushing ID .....	55.948-56.000 (2.2026-2.2047)
Camshaft Bearing Journal-to-Bearing Clearance :	

All except No. 1 Bearing	0.08-0.13-mm (0.003-0.005 in.)
Wear Limit	0.15 mm (0.006 in.)
No.1 Bearing	0.05-0.13 mm (0.002-0.005 in.)
Wear Limit	0.18 mm (0.007 in.)
Lower Block Bore for Seating Liner	115.75-115.80 mm (4.557-4.559 in.)
Upper Block Bore For Seating Liner	120.70-120.75 mm (4.752-4.754 in.)
OD of Liner at Upper Bore	120.61-120.69 mm (4.748-4.751 in.)
Clearance Between Liner and Cylinder Block :	
At Lower Bore	0.035-0.100 mm (0.001-0.004 in.)
At Upper Bore	0.10-0.14 mm (0.004-0.005 in.)
Liner Flange Thickness	6.022-6.058 mm (0.2371-0.2385 in.)
Liner Height Above Block	0.030-0.100 mm (0.0010-0.0040 in.)
Maximum Permissible Height Difference at Nearest Point of Two	
Adjacent Cylinders or Within a Single Cylinder	0.05 mm (0.002 in.)
Thickness of Liner Shim CD15466	0.05 mm (0.002 in.)
Minimum Liner Shim R65833	0.10 mm (0.004 in.)
Minimum Liner Packing Compression	0.13 mm (0.005 in.)
Desired Cylinder Finish (crosshatch pattern)	0.0006-0.0011 mm (25-45 micro-in.)
Cylinder Liner ID	106.48-106.52 mm (4.192-4.194 in.)
Maximum Permissible Wear	0.10 mm (0.004 in.)
Maximum Permissible Taper	0.05 mm (0.002 in.)
Maximum Permissible Out-of-Round	0.05 mm (0.002 in.)
Piston-to-Cylinder Liner Clearance	
(Measured at Bottom of Skirt):	0.08-0.15 mm (0.003-0.006 in.)
Piston OD at 19 mm (0.74 in.) From Bottom of Skirt and	
Measured 90° to Piston Pin	106.38-106.40 mm (4.188-4.189 in.)
Piston Protrusion Above Block	0.08-0.30 mm (0.003-0.012 in.)
Piston Height (Measured From Center of	
Piston Pin Bore to top of Piston):	66.27-66.33 mm (2.609-2.611 in.)
Maximum Allowable Clearance Between	
Second Piston Ring and Ring Groove	0.20 mm (0.008 in.)
Piston Ring End Gap:*	
No. 1 Compression Ring	0.33-0.58 mm (0.013-0.023 in.)
No. 2 Compression Ring	.75-1.00 mm (0.030-0.039 in.)
No. 3 Oil Control Ring	0.33-0.58 mm (0.013-0.023 in.)

*\*When measuring piston ring end gap, No. 2 compression ring gap should be greater than the No. 1 compression ring*

Piston Pin Bore ID	41.285-41.295 mm (1.6254-1.6258 in.)
Piston Pin OD	41.270-41.280 mm (1.6248-1.6252 in.)
Wear Limit	41.257 mm (1.6243 in.)
Connecting Rod Pin Bushing ID (assembled)	41.300-41.326 mm (1.6260-1.6270 in.)
Wear Limit	41.376 mm (1.6290 in.)
Connecting Rod Pin Bore ID (without bushing)	46.025-46.051 mm (1.8120-1.8130 in.)
Piston Pin-to-Bushing Oil Clearance	0.02-0.06 mm (0.0008-0.0024 in.)
Wear Limit	0.10 mm (0.004 in.)
Connecting Rod Bore ID (without bearings):	73.660-73.686 mm (2.9000-2.9010 in.)
Maximum Permissible Bore Out-of-Round:	0.038 mm (0.0015 in.)
Connecting Rod Bore-to-Pin Bushing Bore	
(Center-to-Center) Distance:	180.95-181.05 mm (7.124-7.128 in.)
Connecting Rod Bearing ID (assembled)	69.85-69.90 mm (2.750-2.752 in.)
Connecting Rod Bearing-to-Journal Clearance	0.03-0.10 mm (0.0012-0.0039 in.)
Wear Limit	0.16 mm (0.006 in.)



Crankshaft Rod Journal OD: . . . . .69.80-69.82 mm (2.748-2.749 in.)  
 Undersize Connecting Rod  
 Bearings Available . . . . .0.05, 0.25, 0.51, and 0.76 mm (0.002, 0.01, 0.02, and 0.03 in.)  
 Engine Compression Pressure :  
     Minimum . . . . . 2400 kPa (24 bar) (350 psi)  
     Maximum Difference between Cylinders . . . . . 350 kPa (3.5 bar) (50 psi)  
 Engine Oil Pressure @ 10 5° C (220° F) Sump Temperature \*  
     Minimum at 850 rpm . . . . . 140 kPa (1.4 bar) (20 psi)  
     Maximum at rated speed (2100 rpm) . . . . . 483 kPa (4.83 bar) (70 psi)  
 Maximum Engine Blow-By at Crankcase Vent Tube . . . . . 6.0 m<sup>3</sup>/h (225 cu ft/h)

\* Gauge fluctuations and tolerance extremes can result in readings as high as 586 kPa (5.86 bar) (85 ps)



**Camshaft and Timing Gear Train:**

Camshaft Journal OD . . . . . 55.872-55.898 mm (2.1997-2.2007 in.)  
     Wear Limit . . . . . 55.85 mm (2.199 in.)  
 Camshaft Bore ID (Except No. 1 camshaft bore) . . . . .  
     . . . . . 55.986-56.012 mm (2.2042-2.2052 in.)  
 Camshaft Bushing ID (No. 1 with bushing installed) . . . . .  
     . . . . . 55.948-56.000 mm (2.2026-2.2047 in.)  
 Camshaft Bore (No. 1 bore with bushing removed) . . . . .  
     . . . . . 59.961-59.987 mm (2.3607-2.3617 in.)  
 Camshaft Bore-to-Journal Clearance . . . . . 0.10-0.15 mm (0.004-0.006 in.)  
     Wear Limit . . . . . 0.18 mm (0.007 in.)  
 Camshaft Bushing-to-Journal Clearance (No. 1 bore) . . . . . 0.05-0.13 mm (0.002-0.005 in.)  
     Wear Limit . . . . . 0.18 mm (0.007 in.)  
 Camshaft End Play . . . . . 0.08-0.23 mm (0.003-0.009 in.)  
     Wear Limit . . . . . 0.38 mm (0.015 in.)  
 Camshaft Thrust Plate Thickness . . . . . 3.96-4.01 mm (0.156-0.158 in.)  
     Wear Limit . . . . . 3.83 mm (0.151 in.)  
 Camshaft Follower OD . . . . . 31.61-31.64 mm (1.245-1.246 in.)  
 Cam Follower Bore Diameter in Cylinder Block . . . . . 31.70-31.75 mm (1.248-1.250 in.)  
 Valve Lift at 0.00 mm (in.) Clearance:  
     Intake Valve . . . . . 11.56-12.37 mm (0.455-0.487 in.)  
         Wear Limit . . . . . 11.13 mm (0.438 in.)  
     Exhaust Valve . . . . . 11.28-12.12 mm (0.444-0.477 in.)  
         Wear Limit . . . . . 10.85 mm (0.427 in.)  
 Camshaft Lobe Height:  
     Intake Lobe . . . . . 6.93-7.42 mm (0.273-0.292 in.)  
         Wear Limit . . . . . 6.68 mm (0.263 in.)  
     Exhaust Lobe . . . . . 6.76-7.26 mm (0.266-0.286 in.)  
         Wear Limit . . . . . 6.50 mm (0.256 in.)  
 Upper Idler Gear Shaft OD . . . . . 44.43-44.46 mm (1.749-1.750 in.)  
     Wear Limit . . . . . 44.40 mm (1.748 in.)  
 Upper Idler Gear Bushing ID . . . . . 44.48-44.53 mm (1.751-1.753 in.)  
     Wear Limit . . . . . 44.56 mm (1.754 in.)  
 Lower Idler Gear Shaft OD . . . . . 44.43-44.46 mm (1.749-1.750 in.)  
     Wear Limit . . . . . 44.40 mm (1.748 in.)  
 Lower Idler Gear Bushing ID . . . . . 44.48-44.53 mm (1.751-1.753 in.)  
     Wear Limit . . . . . 44.56 mm (1.754 in.)  
 End Play of Idler Gear . . . . . 0.14-0.29 mm (0.006-0.012 in.)  
     Wear Limit . . . . . 0.40 mm (0.016 in.)

Hub Width of Idler Shaft .....	22.17-22.27 mm (0.873-0.877 in.)
Hub Width of Idler Gear .....	21.98-22.03 mm (0.865-0.867 in.)
Wear Limit .....	21.93mm (0.863 in.)

**Timing Gear Backlash:**

Upper Idler Gear-to-Camshaft Gear .....	0.07-0.35 mm (0.003-0.014 in.)
Wear Limit .....	0.51 mm (0.020 in.)
Upper Idler Gear-to-Injection Pump Gear .....	0.07-0.35 mm (0.003-0.014 in.)
Wear Limit .....	0.51 mm (0.020 in.)
Upper Idler Gear-to-Crankshaft Gear .....	0.07-0.30 mm (0.003-0.012 in.)
Wear Limit .....	0.40 mm (0.016 in.)
Lower Idler Gear-to-Crankshaft Gear .....	0.07-0.35 mm (0.003-0.014 in.)
Wear Limit .....	0.51 mm (0.020 in.)
Lower Idler Gear-to-Oil Pump Gear .....	0.04-0.36 mm (0.0016-0.015 in.)
Wear Limit .....	0.40 mm (0.016 in.)



**Lubrication:**

Oil Pressure Regulating Valve:	
Free Length of Spring (approx.) .....	120 mm (4.72 in.)
Spring Tension at length of 42 mm (1.68 in.) .....	60-75 N (13.5-16.5 lb force)
Oil By-Pass Valve Spring:	
Free Length of Spring .....	59 mm (2.32 in.)
Spring Tension at length of 34 mm (1.34 in.) .....	92-112 N (21-25 lb force)
Minimum Oil Pressure at 850 rpm and engine oil at 93° C (200° F)	
.....	140 kPa (1.4 bar) (20 psi)

**Cooling:**

Water Pump:	
Pump Mounting Flange-to-Impeller Clearance .....	0.0-0.25 mm (0.0-0.01 in.)
Front Face of Pulley-to-Pump Mounting Flange .....	137 mm (5.39 in.)
Impeller Bore .....	15.85-15.88 mm (0.6242-0.6252 in.)
Bearing Shaft OD:	
Impeller End .....	15.90-15.92 mm (0.6262-0.6267 in.)
Pulley End .....	18.95-18.96 mm (0.7460-0.7465 in.)
Pulley/Hub Bore .....	18.91-18.93 mm (0.7445-0.7455 in.)
Thermostat Opening .....	82° C (180° F)
Cooling System Leakage Test Pressure .....	120 kPa (1.2 bar) (17 psi)
Fan Belt Tension:	
Using JDG529 Gauge:	
New Belt .....	578-622 N (130-140 lb force)
Used Belt* .....	378-423 N (85-94 lb force)
Using JDST28 Gauge and Straightedge:	
19 mm (3/4 in.) deflection with 89 N (20 lb force) applied midway between pulley s	
* Belts are considered used after 10 minutes of operation	

**Fuel, Air Intake, and Exhaust:**

Intake Manifold Pressure (Turbo Boost) @ 2100 RPM .....	60 kPa (0.6 bar) (9 psi)
Turbocharger:	
Radial Bearing Clearance (Maximum) .....	0.06-0.13 mm (0.0024-0.005 in.)
Axial Bearing End Play (Maximum) .....	0.025-0.09 mm (0.001-0.0035 in.)

**Fuel Injector:**

Injector Size . . . . .	9.5 mm (0.374 in.)
Nozzle Orifice Diameter . . . . .	0.30 mm (0.012 in.)
Opening Pressure of new or rebuilt nozzle :	
For Setting . . . . .	25100-25800 kPa (251-258 bar)(3650-3750 psi)
For Checking (min.) . . . . .	25200 kPa (252 bar)(3660 psi)
Min. Acceptable Opening Pressure Of Used Nozzle . . . . .	22950 kPa (230 bar)(3330 psi)
Max. Opening Pressure Difference Between Cylinders . . . . .	700 kPa (7 bar)(100 psi)
Nozzle Valve/Seat Tightness Condition at Pressure Test of	
2800-3500 kPa (28-35 bar)(400-500 psi) . . . . .	Nozzle tip still dry after 5 seconds *
(*A slight dampness is permissible on used nozzles)	
Return leakage at pressure test of	
10300 kPa (103 bar)(1500 psi) . . . . .	3-10 Drops / 30 seconds
Nozzle Valve Lift (Based on Zero Lift) . . . . .	3/4 turn counterclockwise



**Fuel Supply Pump:**

Fuel Supply Pump Pressure . . . . .	40-50 kPa (0.40-0.50 bar)(5.75-7.25 psi)
Min. static pressure at 850 rpm engine speed . . . . .	15 kPa (0.15 bar) (2.0 psi)
Min. flow at 2400 rpm engine speed . . . . .	1.5 L/min (0.42 gpm)

**Torques:**

Piston Cooling Orifices Into Cylinder Block . . . . .	10 Nm (7.5 lb-ft) (84 lb-in.)
Connecting Rod Cap Screws	
Initial . . . . .	55 Nm (40 lb-ft)
Final (Do not reuse capscrews after being final torqued) . . . . .	Plus 90-100 Degrees
Crankshaft Main Bearing Cap Capscrews (Reusable after torqued) . . . . .	136 Nm (100 lb-ft)
Rocker Arm Shaft Clamp . . . . .	47 Nm (35 lb-ft)
Rocker Arm Adjusting Screw Jam Nut . . . . .	27 Nm (20 lb-ft)
Cylinder Head Cap Screws: (Reusable after being torqued )	
Step 1 . . . . .	100 Nm (75 lb-ft)
Step 2 . . . . .	150 Nm (110 lb-ft)
Step 3 . . . . .	Wait 5 Minutes and verify 150 Nm (110 lb-ft)
Step 4 . . . . .	Tighten Additional 60° ± 10 °
Fuel Injection Nozzles-To-Cylinder Head . . . . .	37 Nm (27 lb-ft)
Fuel Line Nuts (At Pump And Nozzles) . . . . .	27 Nm (20 lb-ft)
Intake Manifold-to-Cylinder Head . . . . .	47 Nm (35 lb-ft)
Exhaust Manifold-To-Cylinder Head . . . . .	47 Nm (35 lb-ft)
Rocker Arm Cover-to-Cylinder Head . . . . .	11 Nm (8 lb-ft) (96 lb-in.)
Camshaft Thrust Plate-to-Cylinder Block . . . . .	47 Nm (35 lb-ft.)
Oil Pump Drive Gear-to-Shaft, Retaining Nut (Staked) . . . . .	54 Nm (40 lb-ft.)
Upper Idler Gear Cap Screw . . . . .	100 Nm (75 lb-ft.)
Lower Idler Gear Hex Nut (Staked) . . . . .	100 Nm (75 lb-ft.)
Timing Gear Cover-to-Cylinder Block . . . . .	47 Nm (35 lb-ft.)
Fuel Injection Pump Drive Gear-to-Shaft, Retaining Nut . . . . .	200 Nm (150 lb-ft.)
Injection Pump-to-Front Plate Hex. Nuts . . . . .	27 Nm (20 lb-ft.)
Injection Pump Cover, Capscrews . . . . .	2 Nm (17 lb-ft.)
Injection Pump Timing Gear Access Plug . . . . .	30 Nm (22 lb-ft.)
Crankshaft Pulley . . . . .	150 Nm (110 lb-ft.)
Oil Pump-to-Front Plate . . . . .	47 Nm (35 lb-ft.)
Oil Pan-to-Cylinder Block . . . . .	37 Nm (27 lb-ft.)
Oil Pan-to-Timing Gear Cover . . . . .	37 Nm (27 lb-ft.)
Oil Pan-to-Rear Plate of Engine . . . . .	47 Nm (35 lb-ft.)
Oil Pan Drain Plug . . . . .	70 Nm (51 lb-ft.)
Oil Pressure Regulating Valve in Timing Gear Cover . . . . .	95 Nm (70 lb-ft.)
Oil Filter Adapter to Oil Cooler Housing . . . . .	37 Nm (27 lb-ft.)

## SEALANT APPLICATION GUIDELINES

Listed below are sealants which have been tested and are used by the John Deere factory to control leakage and assure hardware retention. ALWAYS use the following recommended sealants when assembling your John Deere Diesel Engine to assure quality performance .

LOCTITE® products are designed to perform to sealing standards with machine oil residue present. If excessive machine oil or poor cleanliness quality exists, clean with solvent. Refer to John Deere Merchandise and Parts Sales Manual for ordering information .

Number	Name	Use
TY9370 6 mL tube T43512 50 mL tube	LOCTITE® 242 Thread Lock & Sealer, Medium Strength (Blue)	Plugs and fittings: fuel filter base, fuel transfer pump, intake manifold, cylinder block Capscrews: crankshaft pulley, injection pump access cover, oil filler inlet, flywheel cover, fuel transfer pump, oil cooler housing-to-cylinder block (open holes only). Oil pressure sending unit
TY9371 6 mL tube T43513 50 mL bottle	LOCTITE® 271 Thread Lock & Sealer, High Strength (Clear)	Studs: water pump-to-cylinder block, injection pump-to-front plate, exhaust manifold-to-turbocharger. Mechanical tachometer drive gear
T43514 50 mL bottle	LOCTITE® 227 Plastic Gasket. High strength (Red)	Steel cap plugs: cylinder block, cylinder head, and water pump. O-ring adapter for oil pump outlet tube
TY6304 50 mL bottle	LOCTITE® 515 Flexible Sealant. General Purpose (Purple)	Flywheel housing-to-cylinder block
TY9374 6 mL tube TY9375 50 mL tube	LOCTITE® 592 Pipe Sealant with Teflon® (White)	Pipe plugs: cylinder block (water manifold), thermostat housing, air intake manifold, water pump, flywheel housing (drain). Dipstick tube threads Injection pump governor cover fitting Threaded nipples and elbows in water pump housing Temperature sending unit Oil pan (drain hose and drain valve) Fittings: turbo oil supply line-to-block, turbo oil return line-to-block.
T43515 50 mL bottle	LOCTITE® 609 Retaining Compound (Green)	Wear ring sleeve-to-crankshaft
TY6304 50 mL bottle	LOCTITE® 515 Flexible Sealant. General Purpose (Purple)	Water pump and thermostat cover gaskets
TY6299 8 oz. tube or DD14996 25 mL tube	PERMATEX® AVIATION (Form-A-Gasket No. 3) or LOCTITE® 518 Flexible Sealant (General Purpose) (red)	Front plate/timing gear cover-to-oil pan Flywheel housing-to-oil pan
PT569	Never-Seez® Compound	Capscrews: Exhaust manifold and turbine housing-to-center housing



LUBRICATION SYSTEM OPERATION

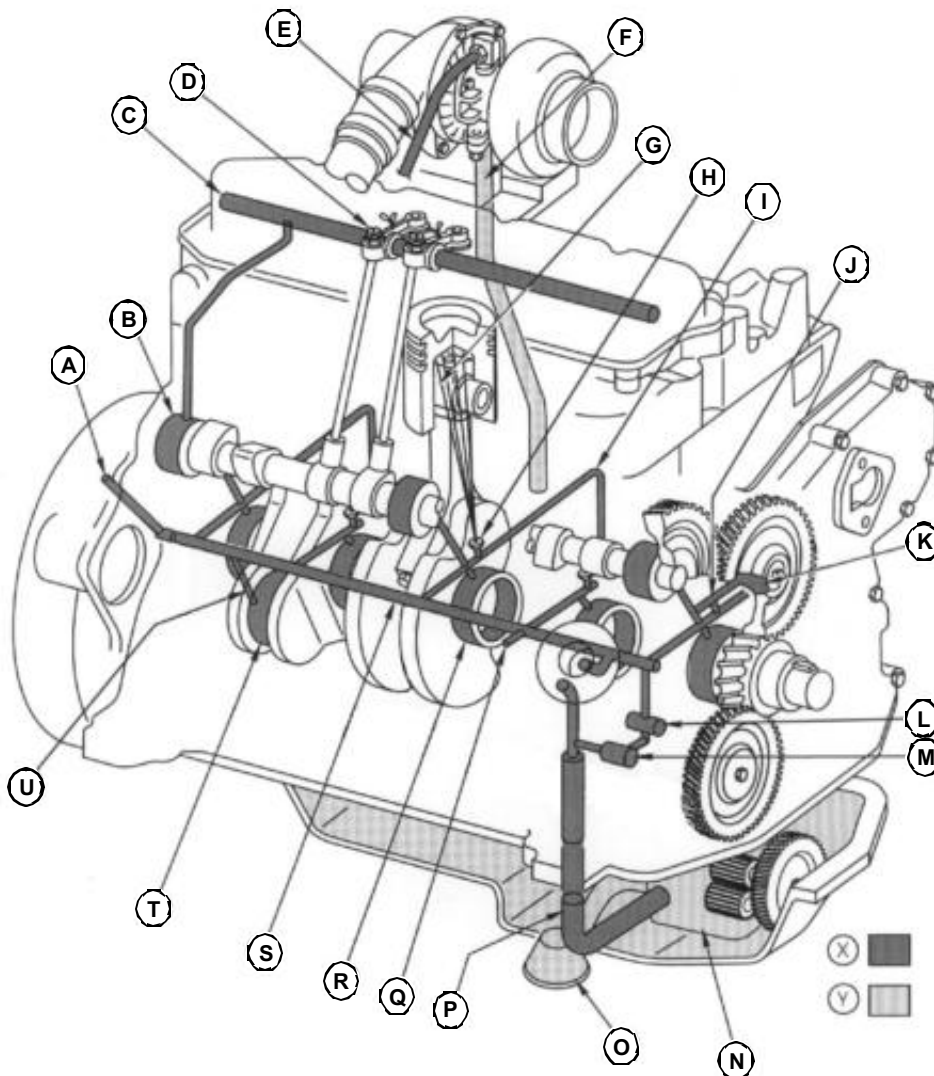

- |                                 |                                    |                               |
|---------------------------------|------------------------------------|-------------------------------|
| A. Turbo Oil Supply             | H. Piston Cooling Orifice          | O. Oil Pickup Tube            |
| B. Rear Camshaft Bearing        | I. Cross-drilling                  | P. Oil Outlet Line            |
| C. Rocker Arm Shaft             | J. Oil Passage-Upper Idler Bushing | Q. Turbo Oil Supply           |
| D. Rocker Arm                   | K. Upper Idler Gear Bushing        | R. Main Bearing               |
| E. Turbocharger Oil Supply Line | L. Oil Pressure Regulating Valve   | S. Main Oil Gallery           |
| F. Turbocharger Oil Drain Line  | M. Oil Pressure Bypass Valve       | T. Connecting Rod Bearing     |
| G. Piston Pin Bushing           | N. Oil Pump                        | U. Main-to-Rod Cross Drilling |

The engine lubrication system consists of a positive displacement gear driven oil pump (N), full flow oil filter, oil cooler, oil pressure regulating valve (L), and oil pressure bypass valve (M).

The oil pump pulls oil from the oil pan sump through a strainer and a pickup tube (O). The pump forces oil through the outlet line (P) into the oil cooler and filter, and on to the main oil gallery (S).

If oil pressure from pump exceeds pressure in main oil gallery (S) by more than  $340 \pm 34$  kPa ( $3.38 \pm 0.34$  bar) ( $49 \pm 5$  psi), oil pressure bypass valve (M) opens. This allows oil to bypass oil cooler and filter, and flow

directly from pump to main oil gallery to prevent oil starvation. Also, oil cooler and oil filter each have their own bypass valve that opens if oil flow becomes restricted.

If oil flow in main oil gallery exceeds a predetermined factory safety factor, the pressure regulating valve (L) opens and relieves excess pressure back to oil pan.

## THEORY OF OPERATION

## FUEL SYSTEM

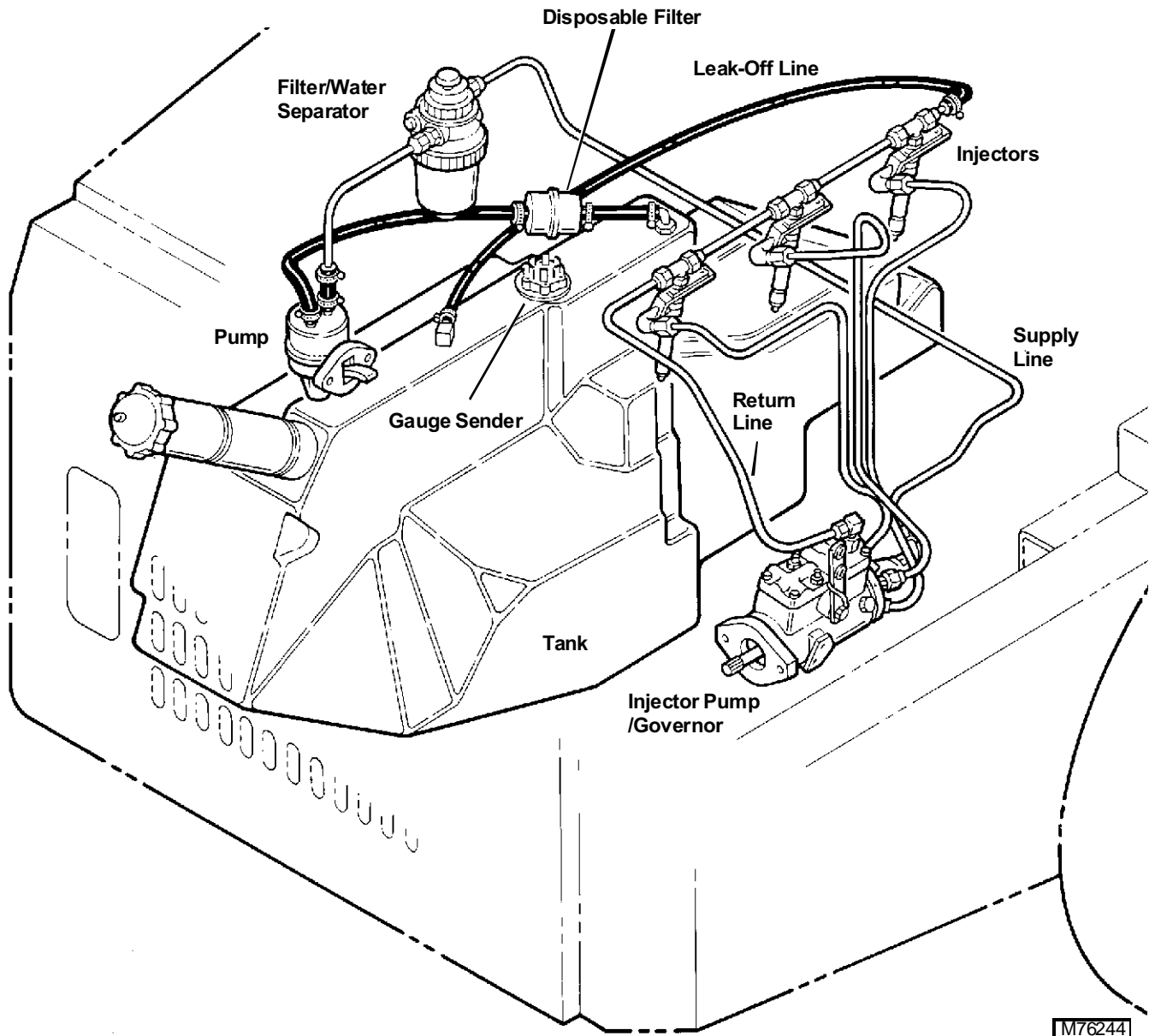
**Theory of Operation**

Fuel is drawn from the fuel tank through a disposable fuel filter, to a mechanical fuel pump driven by the engine camshaft. The fuel pump then delivers fuel under pressure to the water separator/filter, and on to the injector pump/governor. The injection pump meters fuel as determined by its internal governor and throttle position, and delivers high pressure fuel to the injection nozzles.

spraying finely atomized fuel into the combustion chamber. Pressure fuel lines have trapped fuel whenever injection is not taking place.

More fuel is routed through the system than is required for injection. Excess fuel serves to cool and lubricate the injection pump and nozzles. This excess is returned to the fuel tank by the fuel leakoff line. The returning fuel also warms the fuel in the tank.

Each injection nozzle prevents fuel flow until sufficient high pressure is reached, opening the nozzle valve and

**DIAGNOSIS****DIAGNOSING ENGINE MALFUNCTIONS**

- **Will Not Crank**

**Electrical System Malfunction**

Weak battery

Corroded or loose battery connections

Defective main switch or start safety switch

Starter solenoid defective

Starter defective

- **Hard to Start or Will Not Start**

**Electrical System Malfunction**

Loose or corroded battery connections

Weak battery

Excessive resistance in starter circuit

**Fuel System Malfunction**

Empty fuel tank

Improper fuel

Water, dirt or air in fuel system

Plugged fuel filter

Stuck throttle control

Dirty or faulty fuel injection nozzles

Defective fuel injection pump

Defective fuel transfer pump

Fuel injection pump incorrectly timed

**Service Problem**

Too high viscosity crankcase oil

- **Engine Runs Irregularly or Stalls Frequently**

**Basic Engine Problem**

Coolant temperature too low

Improper valve clearance

Cylinder head gasket leaking

Worn or broken compression rings

Valves sticking or burned

Exhaust system restricted

Engine compression too low

Engine overheating

Worn camshaft lobes

**Fuel System Malfunction**

Defective fuel injection pump

Low fuel supply

Fuel injection nozzles defective or leaking

Fuel filter or fuel lines restricted

Defective fuel transfer pump

Fuel injection pump incorrectly timed

- **Engine Misfiring**

**Service Problem**

Water in fuel

Mixture of gasoline and diesel fuel

**Fuel System Malfunction**

Air in fuel system

Defective fuel injection nozzles

Defective fuel injection pump

Fuel injection nozzles improperly installed

Leaking fuel injection nozzle seals

Worn or defective fuel transfer pump

Fuel injection pump incorrectly timed

**Basic Engine Problem**

Engine overheated

Lobes of camshaft worn

Weak valve springs

Preignition

Engine compression too low

Improper valve clearance

Burnt, damaged or stuck valves

- **Lack of Engine Power**

**Service Problem**

Air cleaner restricted or dirty

Excessive resistance in air intake system

Improper crankcase oil



**Fuel System Malfunction**

Fuel filter restricted  
 Defective fuel transfer pump  
 Defective fuel injection pump  
 Fuel injection pump incorrectly timed

**Basic Engine Problem**

Engine overheated  
 Defective cylinder head gasket  
 Lobes of camshaft worn  
 Improper valve clearance  
 Improper valve timing  
 Burnt, damaged or stuck valves  
 Weak valve springs  
 Piston rings and cylinder liners excessively worn  
 Engine compression too low  
 Improper coolant temperature

- **Engine Overheats**

**Service Problem**

Lack of coolant in cooling system  
 Radiator and/or oil cooler cores dirty  
 Cooling system limed up  
 Engine overloaded  
 Too low crankcase oil level

**Basic Engine Problem**

Loose or defective fan belt  
 Defective thermostat  
 Damaged cylinder head gasket  
 Defective water pump  
 Defective radiator cap

**Fuel System Malfunction**

Fuel injection pump delivers too much fuel  
 Fuel injection pump incorrectly timed

- **Excessive Oil Consumption**

**Basic Engine Problem**

Oil control rings worn or broken  
 Scored cylinder liners or pistons  
 Excessive resistance in air intake system

Oil flow through oil passages restricted  
 Worn valve guides or stems  
 Excessive oil pressure  
 Piston ring grooves excessively worn  
 Piston rings sticking in ring grooves  
 Insufficient piston ring tension  
 Piston ring gaps not staggered  
 Excessive main or connecting rod bearing clearance  
 Front and/or rear crankshaft oil seal faulty  
 Glazed cylinder liners (insufficient load during engine break-in)

**Service Problem**

Too low viscosity crankcase oil  
 Crankcase oil level too high  
 External oil leaks

- **Low Oil Pressure**

**Service Problem**

Low crankcase oil level  
 Improper crankcase oil  
 Defective oil pressure warning switch or engine oil pressure indicator light

**Basic Engine Problem**

Leakage at internal oil passages  
 Defective oil pump  
 Excessive main and connecting rod bearing clearance  
 Improper regulating valve adjustment  
 Piston cooling orifice missing

- **High Oil Pressure**

**Basic Engine Problem**

Oil pressure regulating valve bushing loose (wanders)  
 Improperly operating regulating valve  
 Stuck or damaged filter bypass valve

- **Excessive Fuel Consumption**

**Service Problem**

Engine overloaded  
 Air cleaner restricted or dirty

**Basic Engine Problem**

Compression too low

**Fuel System Malfunction**

Leaks in fuel system

Fuel injection nozzles dirty or faulty

Fuel injection pump defective (delivers too much fuel)

Fuel injection pump incorrectly timed



- **Black or Grey Exhaust Smoke**

**Service Problem**

Excess fuel

Engine overloaded

Air cleaner restricted or dirty

Defective muffler (causing back-pressure)

**Fuel System Malfunction**

Fuel injection nozzles dirty or faulty

Incorrect engine timing

- **White Exhaust Smoke**

**Basic Engine Problem**

Engine compression too low

Defective thermostat (does not close)

**Fuel System Malfunction**

Defective fuel injection nozzles

Fuel injection pump incorrectly timed

- **Coolant in Crankcase**

**Basic Engine Problem**

Cylinder head gasket defective

Cylinder head or block cracked

Cylinder liner seals leaking

- **Abnormal Engine Noise**

**Basic Engine Problem**

Worn main or connecting rod bearings

Excessive crankshaft end play

Loose main bearing caps

Foreign material in combustion chamber

Worn connecting rod bushings and piston pins

Scored pistons

Worn timing gears

Excessive valve clearance

Worn cam followers

Bent push rods

Worn camshaft

Worn rocker arm shaft

Insufficient engine lubrication

Worn turbocharger bearings

**Fuel System Malfunction**

Fuel injection pump incorrectly timed

- **Detonation or Pre-Ignition**

**Basic Engine Problem**

Oil picked up by intake air stream (intake manifold)

**Fuel System Malfunction**

Dirty or faulty fuel injection nozzle

Incorrect fuel injection pump timing

Fuel injection nozzle tip holes enlarged

Fuel injection nozzle tips broken

Carbon buildup in combustion chamber

- **Water Pump Leaking**

Seal ring or pump shaft worn

- **Coolant Temperature Below Normal**

Defective thermostat

Coolant temperature gauge defective

- **Engine Vibrating**

Fan blades bent or broken

Water pump shaft worn

## CYLINDER LINER, PISTON, AND CONNECTING ROD DIAGNOSIS

**Scuffed or Scored Pistons:**

Overheating.

Overfueling.

Insufficient lubrication.

Insufficient cooling.

Improper piston-to-liner clearance .  
 Coolant leakage into crankcase .  
 Misaligned or bent connecting rod .  
 Improperly installed piston .  
 Low oil level .  
 Improper operation .  
 Incorrect connecting rod bearing clearance .  
 Carbon buildup in ring groove .  
 Improper engine break-in .  
 Worn piston .  
 Contaminated oil .  
 Distorted cylinder liner .  
 Plugged piston cooling orifice .  
 Ingestion of dust through air intake .

#### **Worn or Broken Compression Rings:**

Insufficient lubrication .  
 Insufficient cooling .  
 Improper ring installation .  
 Improper combustion .  
 Improper timing .  
 Abrasives in combustion chamber .

#### **Clogged Oil Control Ring:**

Improper oil .  
 Excessive blowby .  
 Improper periodic service .  
 Low operating temperature .

#### **Stuck Rings:**

Improper oil classification .  
 Improper periodic service .  
 Poor operating conditions .  
 Coolant leakage into crankcase .  
 Excessive cylinder liner taper .

#### **Cylinder Liner Wear and Distortion:**

Incorrectly installed compression rings .  
 Insufficient lubrication .  
 Uneven cooling around liner .  
 Inadequate piston-to-liner clearance .  
 Liner bore damage .

#### **Warped Cylinder Block:**

Insufficient cooling .

#### **Broken Connecting Rod:**

Inadequate piston-to-liner clearance .  
 Worn connecting rod bearing .  
 Distorted cylinder liner .  
 Piston pin failure .

#### **Piston Pin and Snap Ring Failure:**

Misaligned connecting rod .  
 Excessive crankshaft end play .  
 Incorrect snap rings .

#### **Mottled, Grayish or Pitted Compression Rings:**

Internal coolant leaks .

#### **Dull Satin Finish and Fine Vertical Scratches on Rings:**

Dirt and abrasive in air intake system .



## **CYLINDER HEAD AND VALVE DIAGNOSIS**

#### **• Sticking Valves:**

Carbon deposits on valve stem .  
 Worn Valve guides .  
 Scored valve stems .  
 Warped valve stems .  
 Cocked or broken valve springs .  
 Worn or distorted valve springs .  
 Worn or distorted valve seats .  
 Insufficient lubrication .

#### **• Warped, Worn, or Distorted Valve Guides:**

Lack of lubrication .  
 Cylinder head distortion .  
 Excessive heat .  
 Unevenly tightened cylinder head cap screws .

#### **• Distorted Cylinder Head and Gasket Leakage:**

Loss of cylinder head cap screw torque .  
 Broken cylinder head cap screw .  
 Overheating from low coolant level operation .  
 Insufficient Liner standout .

Coolant leakage into cylinder causing hydraulic failure of gasket.

Crazed cylinder head.

Cracked cylinder liner.

Damaged or incorrect gasket.

Overpowering or Overfueling.

Damaged cylinder head or block surfaces.

Improper surface finish on cylinder head.

Improperly tighten cylinder head cap screws.

Faulty gasket installation (misaligned).



• **Worn or Broken Valve Seats:**

Misaligned valves.

Distorted cylinder head.

Carbon deposits on seats due to incomplete combustion.

Valve spring tension too weak.

Excessive heat.

Improper valve clearance.

Improper valve timing.

• **Burned, Pitted, Worn, or Broken Valves:**

Worn or distorted valve seats.

Loose Valve Seats.

Worn valve guides.

Insufficient cooling.

Cocked or broken valve springs.

Improper engine operation.

Improper valve train timing.

Faulty valve rotators.

Warped or distorted valve stems.

“Stretched” valves due to excessive spring tension.

Warped cylinder head.

Bent push rods.

Carbon buildup on valve seats.

Rocker arm failure.

• **Improper Valve Clearance:**

Inefficient use of fuel.

Engine starts harder.

Maximum engine power will not be achieved.

Shorter service life of valve train.

Greater chance for engine to overheat.

## CRANKSHAFT DIAGNOSIS

• **Scored Main Bearing:**

(Diagnosis also applies to connecting rod bearing.)

Oil starvation.

Contaminated oil.

Engine parts failure.

Excessive heat.

Poor periodic service.

• **Galled or “Wiped” Bearings:**

Fuel in lubricating oil (incomplete combustion).

Coolant in lubrication system (cracked block, liner seal failure, or leaking water pump seal with plugged hole).

Insufficient bearing oil clearance.

Parts not lubricated prior to engine operation.

Wrong bearing size.

• **Inconsistent Wear Pattern:**

Misaligned or bent connecting rod

Warped or bowed crankshaft.

Distorted cylinder block.

• **Broken Main Bearing Caps:**

Improper installation.

Dirt between bearing and crankshaft journal.

Low oil pressure.

Oil pump failure.

• **Cracked, Chipped or Broken Bearings:**

Overspeeding.

Excessive idling.

Lugging.

Excessive oil clearance.

Improper installation.

## FUEL SYSTEM DIAGNOSIS



Symptom	Problem	Solution
Engine Starts and Stops	Air in system	Correct problem & bleed fuel system.
	Fuel filter restricted	Replace fuel filter.
	Fuel lines restricted	Clean lines as required.
	Water in fuel	Drain water in separator. Replace filter.
	Injection pump return fuel line or fittings restricted	Clean lines as required.
Erratic Engine Operations	Fuel filter restricted	Replace fuel filter.
	Fuel too heavy at low temperatures	Replace with correct grade of fuel.
	Injection nozzles faulty or sticking	Clean, adjust, or replace nozzles.
	Fuel lines restricted	Clean as required.
	Incorrect timing	Adjust injection pump timing.
	Governor faulty	Replace injection pump
	Water in fuel	Drain water in separator. Replace filter.
	Injection pump return fuel line or fittings restricted	Clean lines as required.
	Low cetane fuel	Replace with correct grade of fuel.
	Injection nozzle return lines restricted	Clean lines as required.
Excessive Black Smoke	Injection nozzles faulty or sticking	Clean, adjust, or replace nozzles.
	Injection pump timing incorrect	Adjust injection pump timing.
	Low cetane fuel	Replace with correct grade of fuel.
	Overfueling	Repair injection pump.
Excessive Blue/White Smoke	Cranking speed too slow	Check batteries and electrical system.
	Injection pump timing incorrect	Adjust injection pump timing.
	Injection nozzles faulty or sticking	Clean, adjust, or replace nozzles.
	Excessive wear in liners and/or piston rings stuck	See Engine Repair Section.
	Incorrect cetane fuel for temperature	Replace with correct grade of fuel.
Engine Idles Poorly	Engine running too "cold"	Check Thermostat.
	Injection nozzles faulty or sticking	Clean, adjust, or replace nozzles.
	Incorrect timing	Adjust injection pump timing.
	Slow idle speed not correct.	Adjust slow idle speed.
	Fuel lines restricted	Clean as required.
	Water in fuel	Drain water in separator. Replace filter.
	Injection pump return lines or fittings restricted	Clean as required.
	Injection nozzle return lines clogged	Clean as required.
Low cetane fuel	Replace with correct grade of fuel.	



<b>Symptom</b>	<b>Problem</b>	<b>Solution</b>
Engine Does Not Develop Full Power	Low cetane fuel	Replace with correct grade of fuel.
	Incorrect timing	Adjust injection pump timing.
	Injection pump or governor faulty	Replace injection pump.
	Fuel filter clogged	Replace fuel filter.
	Injection nozzles faulty or sticking	Clean, adjust, or replace nozzles.
	Defective supply pump	Test fuel supply pump.
	Injection pump return fuel line or fittings restricted	Clean as required.
	Water or gasoline in diesel fuel	Drain water or replace with clean fuel. Install new filters.
	Incorrect pump return fuel line or fittings restricted	Clean as required.
	Water or gasoline in diesel fuel	Drain water or replace with clean fuel. Install new filters.
Incorrect fast idle speed	Adjust injector pump high speed stop.	
Throttle control linkage incorrectly adjusted	Adjust cable to allow full injector pump arm travel.	

**FUEL SUPPLY PUMP DIAGNOSIS**

<b>Symptom</b>	<b>Problem</b>	<b>Solution</b>
Low Supply Pump Pressure or Pump Not Functioning Correctly	Out of fuel	Add fuel to tank.
	Restricted fuel line	Clean as required.
	Air leak in fuel line between pump and tank	Repair as required.
	Hand primer lever left in upward position	Move lever toward engine block as far as it will go.
	Punctured or leaking diaphragm	Replace pump.
	Worn or damaged valve assemblies	Replace pump.
	Broken valve spring(s)	Replace pump.
	Foreign material under diaphragm (from vent holes)	Replace pump.
	Wear or damage to hand primer linkage	Replace pump.

### FUEL INJECTION NOZZLE DIAGNOSIS

Symptom	Problem	Solution
Engine has Low Horsepower	Nozzle orifices plugged	Repair.
	Incorrect nozzle valve opening pressure	Adjust.
	Broken, worn or damaged parts : -Broken nozzle valve spring -Cracked or split nozzle tip -Cracked or split nozzle body -Internal leak	Repair as required.
	Wrong nozzle assembly installed	Install correct nozzle assembly.
Engine Emits Too Much Smoke	Nozzle loose in cylinder head	Make sure nozzle assembly is installed to specified torque.
	Nozzle orifices plugged	Repair.
	Broken, worn or damaged parts : -Broken nozzle valve spring -Cracked or split nozzle tip -Cracked or split nozzle body -Internal leak	Repair as required.
	Wrong nozzle assembly installed	Install correct nozzle assembly.



## FUEL INJECTION NOZZLE DIAGNOSIS



Problem	Possible Cause	Suggested Remedy
Failed Carbon Stop Seal Washer	Nozzle replaced without using new seal or washer.	Install new seal or washer.
	Carbon stop seal groove not cleaned when new seal was installed .	Clean groove. Install new seal .
Incorrect Opening Pressure	Improper adjustment .	Adjust opening pressure.
	Broken spring .	Replace spring.
Nozzle Will Not Open	Plugged orifices .	Clean.
	Chipped orifices .	Replace nozzle.
	Bottomed lift screw .	Adjust lift screw .
Poor Spray Pattern	Plugged orifices .	Clean.
	Chipped orifices .	Replace nozzle.
	Cracked nozzle tip .	Replace nozzle.
Poor Atomization	Plugged orifice .	Clean.
	Chipped orifice .	Replace nozzle.
	Cracked nozzle tip .	Replace nozzle.
	Valve not free .	See "Inconsistent Chatter".
Inconsistent Chatter	Spring components misaligned .	Adjust opening pressure.
	Varnish on valve .	Clean guide area .
	Deposits in seat area .	Clean seat.
	Bent valve .	Replace nozzle.
	Distorted body .	Replace nozzle.
No Chatter	Spring components misaligned .	Adjust opening pressure.
	Varnish on valve .	Clean guide area .
	Deposits in seat area .	Clean seat.
	Bent valve .	Replace nozzle.
	Valve seat eroded or pitted .	Lap valve to seat. Replace nozzle as necessary.
	Seat interference angle worn .	Replace nozzle.
	Distorted body .	Replace nozzle.
Seat Leakage	Deposits in seat area .	Clean seat.
	Valve seat eroded or pitted .	Lap valve to seat. Replace nozzle as necessary.
	Tip seat pitted .	Lap tip to seat. Replace nozzle as necessary.
	Distorted body .	Replace nozzle.
	Cracked tip .	Replace nozzle.
High Leak-Off	Wear or Scratched at Guide .	Lap valve to guide. Replace nozzle .
Low Leak-Off	Varnish on valve .	Clean guide area .
	Insufficient clearance .	Clean nozzle. Lap valve to guide. Replace nozzle as necessary.

## FUEL INJECTION PUMP DIAGNOSIS

Symptom	Problem	Solution
Engine Starts Hard or Won't Start	Shut-off solenoid not functioning properly; or wiring lead loose or broken	Test for voltage at injector pump terminal. If present, test for fuel at injectors.
	Injection pump not correctly timed	Adjust injection pump timing.
	Defective injection pump	Remove pump from engine and repair.
Slow Idle Speed Irregular	Automatic advance faulty or not operating	Repair or replace injector pump.
	Nozzle faulty or sticking	Clean, adjust, or replace nozzles.
	Automatic advance faulty or not operating	Repair or replace injector pump.
Engine Horsepower Low	Injection pump not properly timed	Check pump timing.
	Defective injection pump	Remove pump and repair.
	Pump not properly timed	Check timing.
	Insufficient throttle arm travel	Inspect and adjust.
Engine Horsepower Low	Automatic advance faulty or not operating	Adjust or repair.
	Nozzle faulty or sticking	Repair.
	Defective injection pump	Remove pump and repair.



## AIR INTAKE SYSTEM DIAGNOSIS

Symptom	Problem	Solution
Engine Starts Hard or Won't Start	Air leak on suction side of system	Check hose and pipe connections for tightness; repair as required.
Erratic Engine Operation	Air leak on suction side of system	Check hose and pipe connections for tightness; repair as required.
Engine Emits Excessive Black Smoke	Air cleaner element restricted	Clean or replace elements (See operator's manual).
Engine Idles Poorly	Air leak on suction side of system	Check hose and pipe connections for tightness; repair as required.
Engine Does Not Develop Full Power	Air cleaner restricted	Clean or replace elements (See operator's manual).
	Air leak on suction side of system	Check hose and pipe connections for tightness; repair as required.
Turbocharger "Screams"	Turbocharger defective	Repair or replace.
	Air leak in manifold	Check intake manifold gasket and manifold; repair as required.

TESTS AND ADJUSTMENTS

VALVE ADJUSTMENT

NOTE: Valve clearance can be checked with engine cold or warm.

1. Remove rocker arm cover and ventilator tube .

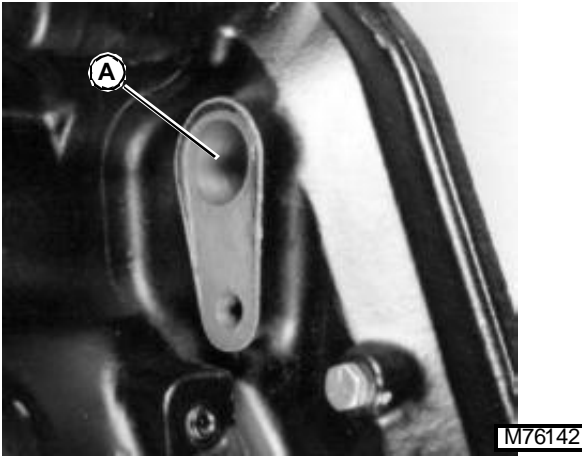

M76142

2. Remove cover plug from engine timing holes (A) .
3. Using engine rotation tool, rotate engine in running direction (clockwise viewed from front of engine, or rear of Skid-Steer Loader) until No. 1 cylinder is at top dead center of compression stroke .

NOTE: If No. 1 cylinder rocker arms are loose, the engine is at No. 1 "TDC-Compression". If No. 1 cylinder rocker arms are not loose, rotate engine one full revolution (360°)

4. Insert timing pin to lock flywheel at TDC for No. 1 cylinder

T81224

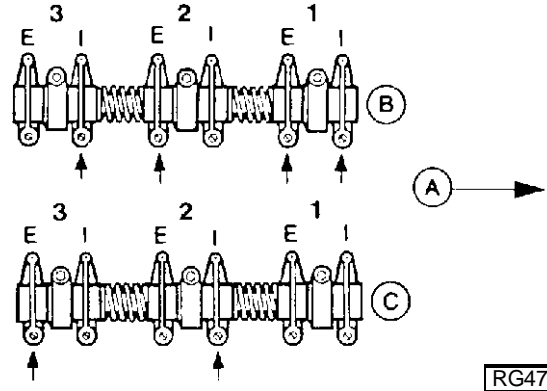

RG4775

- A. Front of Engine
- B. No. 1 TDC Compression Stroke
- C. No. 1 TDC Exhaust Stroke

4. Check valve clearance from rocker arm to valve tip with feeler gauge on No. 1 and 2 exhaust valves, and No. 1 and 3 intake valves. Adjust if necessary .

Intake Valve . . . . . 0.35 mm (0.014 in.)

Exhaust Valve . . . . . 0.45 mm (0.018 in.)

NOTE: Firing order is 1-2-3

5. Remove timing pin and turn crankshaft 36 0°. Lock No. 1 piston at TDC exhaust stroke .
6. Check valve clearance from rocker arm to valve tip with feeler gauge on No.3 exhaust valve, and No. 2 intake valve. Adjust if necessary .

VALVE LIFT MEASUREMENT

NOTE: For a more accurate measurement, measure valve lift at 0.00 mm (in.) rocker arm-to-valve tip clearance.

1. Remove rocker arm cover .
2. Lock No. 1 piston at TDC compression stroke .
3. Set rocker arm-to-valve tip clearance to 0.00 mm (in.) for No. 1 and 2 exhaust, and No. 1 and 3 intake valves.

(See Valve Adjustment section for valve location)

RG6308

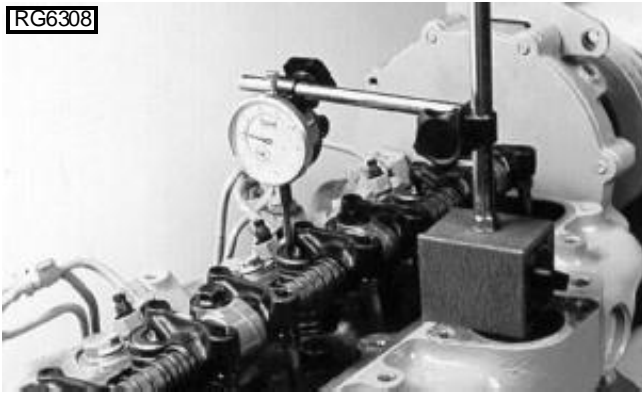

4. Place dial indicator tip on top of valve spring retainer or rotator. Preload indicator tip and set dial at 0.0 mm (in.)
5. Remove timing pin from flywheel and manually rotate engine one full revolution ( $360^\circ$ ) in running direction.
6. Observe dial indicator reading as valve is moved to full open. Record maximum reading and compare with specifications given below.

#### Valve Lift Specification

##### (At 0.00 mm (in.) Valve Clearance)

Intake Valves . . . . . 11.56-12.37 mm (0.455-0.487 in.)  
Wear Limit . . . . . 11.13 mm (0.438 in.)

Exhaust Valves . . . . . 11.28-12.12 mm (0.444-0.477 in.)  
Wear Limit . . . . . 10.85 mm (0.427 in.)

7. If valve lift is within specifications, adjust valve clearance as specified in Valve Clearance Adjustment Section.
8. If valve lift on one or more valves is not within specification, remove and inspect entire valve train and camshaft.
9. Rotate engine one full revolution ( $360^\circ$ ). Lock engine at TDC of No. 1 exhaust stroke.
10. Set rocker arm-to-valve tip clearance to 0.0 mm (in.) for No. 3 exhaust and No. 2 intake valves.
11. Repeat steps 4-7.

## PRELIMINARY ENGINE TESTING

The following preliminary tests will help determine if the engine can be tuned-up to restore operating efficiency, or if engine rebuilding is required.

1. After engine has stopped for several hours, loosen crankcase drain plug and watch for any water to seep out. A few drops due to condensation is normal, but more than this would indicate problems which require engine repair.

2. With engine stopped, inspect engine coolant for oil film. With engine running, inspect coolant for air bubbles. Either condition would indicate problems which require engine repairs rather than just a tune-up.
3. Perform a dynamometer test and record power output. Repeat dynamometer test after tune-up. Compare power output before and after tune-up.
4. Perform compression test.

## ENGINE COMPRESSION PRESSURE TESTING

*NOTE: Before beginning test, insure that batteries are fully charged and injection nozzle area is thoroughly cleaned. Adapters and test fittings are part*

1. Run engine to bring up to normal operating temperature. (From a cold start, operate engine 10-15 minutes at slow idle.)
2. Remove fuel injection nozzles. (See Fuel Repair Section.)



RG5646

3. Install JT01679 Adapter with O-ring in injection nozzle bore. Use JT02017 Holding Clamp to hold JT01679 Adapter in position. Install hold down screw in clamp and tighten screw to **37 Nm (27 lb ft)**. Attach JT016582 Test Gauge to adapter.
4. Remove wire from connector on top of fuel injection pump to prevent engine from starting. Turn crankshaft for 10-15 seconds with starting motor (minimum cranking speed—150 rpm cold/200 rpm hot).
5. Compare readings from all cylinders.

6. Compression pressure must be **2400 kPa (24 bar) (350 psi)** minimum. The difference between the highest and lowest cylinder must be less than **350 kPa (3.5 bar) (50 psi)**.
7. If pressure is much lower than shown, remove gauge and apply oil to ring area of piston through injection nozzle bore. Do not use too much oil. Do not get oil on the valves.
8. Test compression again. If pressure is high, worn or stuck rings are indicated. If pressure is still low, it is possible that valves are worn or sticking.



## ENGINE OIL PRESSURE TEST

1. Remove oil pressure sender and install pressure gauge capable of 0-100 psi from JTO5470 Pressure Test Kit.

**IMPORTANT:** Warm up engine to allow the lubricating oil to reach operating temperature, or high oil pressure readings will occur.

2. At 850 rpm engine speed and 93° C (200° F) oil temperature, gauge should show a minimum pressure of 140 kPa (1.4 bar) (210 psi).
3. At 2100 rpm and 105° C (220° F) oil temperature, gauge should show a pressure of 380 ± 103 kPa (3.80 ± 1.03 bar) (55 ± 15 psi) on all engines.

*NOTE: Tolerance extremes and gauge fluctuations can result in a gauge reading of up to 582 kPa (5.82 bar) (85 psi). This is not detrimental to the engine.*

## INTAKE MANIFOLD PRESSURE (TURBO BOOST) TEST



1. Remove manifold heater from intake manifold and install JT03470 fitting (A) from JDE147 Kit. Connect gauge and test line to fitting.
2. Before checking boost pressure, warm up engine to allow the lubricating oil to reach operating temperature.

**IMPORTANT:** Engine speed and load should be stabilized before taking readings on gauge. Be sure that gauge works properly.

Pressure checks are only a guide to determine if there is an engine problem (valve leakage, defective nozzles, etc.). Low readings are not a valid reason for increasing injection pump fuel delivery. Pump adjustment should be within specification as established by an authorized pump repair station.

3. Observe pressure reading on gauge. Reading should be at least **60 kPa (0.6 bar) 9 psi** when engine is developing rated power at full load rated speed.
  - If boost pressure is too high, remove and test fuel injection pump for high fuel delivery.
  - If boost pressure is too low, check for the following :
    - Restricted air filter elements.
    - Restricted fuel filter elements.
    - Incorrect fast idle adjustment.
    - Incorrect injection pump timing.
    - Exhaust manifold leaks.
    - Intake manifold leaks.
    - Faulty fuel transfer pump.
    - Low compression pressure.
    - Faulty fuel injection nozzles.
    - Carbon buildup in turbocharger.
    - Turbocharger compressor or turbine wheel rubbing housing.
    - Low fuel injection pump fuel delivery.
    - Restricted exhaust.
4. After testing, remove test gauge and fittings.
5. Install air manifold heater using thread sealant.
6. Install manifold heater electrical wire to terminal.

## CRANKCASE VENTILATION SYSTEM INSPECTION

1. Inspect crankcase ventilation system for restrictions. Lack of ventilation causes sludge to form in crankcase. This can lead to clogging of oil passages, filters and screens, resulting in serious engine damage.
2. Clean crankcase vent tube with solvent and compressed air if restricted. Install and tighten hose clamps securely.

## AIR INTAKE SYSTEM INSPECTION

1. Replace air cleaner primary and secondary filter elements.
2. Check condition of air intake hoses. Replace if cracked, split or otherwise in poor condition .
3. Check hose clamps for tightness. Replace clamps that cannot be properly tightened. This will prevent dust from entering the air intake system and causing serious engine damage .

## CHECK EXHAUST SYSTEM

1. Inspect exhaust system for leaks or restrictions. Check manifold for cracks. Repair or replace as necessary.
2. Inspect gasket seals at turbocharger and cylinder head for leakage.
3. Check torque of exhaust manifold capscrews .
4. Check clamp from to muffler to turbocharger to make sure it is tight and not leaking. Correct as necessary.

## COOLING SYSTEM & RADIATOR CAP PRESSURE TEST

1. Visually inspect radiator for leaks or damage .

### C CAUTION

Remove radiator filler cap only when coolant temperature is below operating temperature. Always loosen cap slowly to the stop to relieve pressure before removing cap.

2. Remove radiator cap.
3. Attach D05104ST Pressure Pump to radiator filler neck, following manufacturers instructions .
4. Pressurize cooling system to 120 kPa (1.2 bar) (17 psi).
5. Check engine, radiator, and hoses for coolant leaks.
6. Release pressure and repair system as necessary, if it does not hold pressure .
7. Install radiator cap onto D05104ST tester .
8. Pressurize to 100-120 kPa (1.0-1.2 bar) (14-17 psi). Replace cap if it does not hold pressure .

## FUEL DRAIN BACK TEST

Fuel draining back through the fuel system may cause hard starting. This procedure will determine if air is entering the system at connections and allowing fuel to siphon back to the fuel tank .

1. Disconnect fuel supply line and fuel return line at fuel tank .
2. Drain all fuel from the system, including the fuel transfer pump, fuel injection pump, fuel filters, and water separator .
3. Securely plug off the end of the fuel return pipe .
4. Using a low pressure air source, pressurize the fuel system at the fuel supply line to **100 kPa (1 bar) (15 psi)**.

### C CAUTION

Maximum air pressure should be **100 kPa (1 bar) (15 psi)** when performing this test.



5. Apply liquid soap and water solution to all joints and connections in the fuel system and inspect for leaks.

*NOTE: Connections may allow air to enter the system without allowing fuel to leak out*

6. If any leaks are found, take necessary steps to repair.
7. Reconnect supply and return lines and prime system .
8. Start engine and run for approximately 10 minutes .
9. Allow engine to sit overnight and try starting the following morning .

## REPAIR

### CLEAN ENGINE

1. Cap or plug all openings on engine. If electrical components (starter, alternator, etc.) are not removed prior to cleaning, cover with plastic and tape securely to prevent moisture from entering .
2. Steam-clean engine thoroughly .

**IMPORTANT: Never steam clean or pour cold water on an injection pump while it is still warm. To do so may cause seizure of pump parts.**

### ENGINE REMOVAL (CAB TILTED)

1. Park machine on level surface with bucket removed, lock park brake, roll bucket attachment plate back, lock boom in up position, stop engine .
2. Open engine cover and remove side panels .
3. Disconnect negative battery cable clamp from battery post .
4. Jack and block up frame. Follow procedure for cab and boom tilt using cab jack (see Cab Tilt section) .

5. Remove muffler .
6. Disconnect positive battery cable clamp and battery hold-down. Remove battery .
7. Remove muffler mounting capscrews and clamp to turbo charger. Remove muffler .
8. Tag, label and remove wires to starter, alternator, engine ground tie point, engine ground strap, coolant temperature sender, manifold heater, oil pressure switch, hydraulic reservoir temperature sender, fuel injection pump, hydraulic filter and fuel sender. Pull engine harness clear of engine .
9. Open rear access door and tip out radiator. Drain coolant and remove upper and lower radiator hoses from engine .
10. Loosen clamps on air inlet hose and disconnect hose from air filter. Remove air filter mounting bolt. Unlatch air filter mounting clamp and slide filter housing out of mounting bracket .
11. Remove bolt holding throttle cable to fuel injector pump .
12. Disconnect fuel hoses from fuel pump to tank .
13. Remove skid plate under engine. Drain hydraulic reservoir into a drain pan by loosening hydraulic line tee-fitting under battery .
14. Remove engine mounting bolts .
15. Remove access plate below hydrostatic transmission on bottom of machine. Remove transmission mounting bolt through access hole .
16. Disconnect pump control arm linkages where attached to drive control rods .
17. Disconnect all hydraulic hoses from hydrostatic transmission to chassis .
18. Attach suitable engine sling to engine lift brackets. (See Engine Lifting Procedure Section) Lift engine and hydrostatic transmission up keeping fan clear of fan shroud .



1. Attach JDG23 Engine Lift Sling or equivalent to engine lifting straps and overhead hoist or floor crane .

*NOTE: If engine does not have lifting straps, they can be procured through service parts*

2. Adjust center of balance to equalize load of engine, engine gearbox, and hydrostatic pumps .

**IMPORTANT: Use overhead crane or floor hoist rated to lift 907 kg (2000 lbs).**

## ENGINE REPAIR STAND

### C CAUTION

**Never mount engine on a repair stand not capable of supporting engine weight.**

#### Safety Precautions

- The engine repair stand should be used only by qualified service technicians familiar with this equipment .
- To maintain shear strength specifications, alloy steel SAE grade 8 or higher socket head cap screws must be used to mount adapters or engine .
- For full thread engagement, be certain that tapped holes in adapters and engine blocks are clean and not damaged. A thread length engagement equal to 1-1/2 screw diameters minimum is required to maintain strength requirements .
- To avoid structural or personal injury, do not exceed the maximum capacity rating of the engine stand .
- To avoid an unsafe off-balanced load condition, the center of balance of an engine must be located within 51 mm (2in.) of the engine stand rotating shaft. Engine center of balance is generally located a few millimeters above the crankshaft .
- To prevent possible personal injury due to engine slippage, recheck to make sure engine is solidly mounted before releasing support from engine lifting device .
- Never permit any part of the body to be positioned under a load being lifted or suspended. Accidental slippage may result in personal injury .
- The lifting jack is to be used when it is necessary to lift the engine for rotation. When working on the engine, the jack should be at its lowest position to keep the center of gravity low and the possibility of tipping low .
- To prevent possible personal injury due to sudden engine movement, lower engine by operating jack release valve slowly. Do not unscrew release valve knob more than two turns from its closed position .

## ENGINE LIFTING PROCEDURE

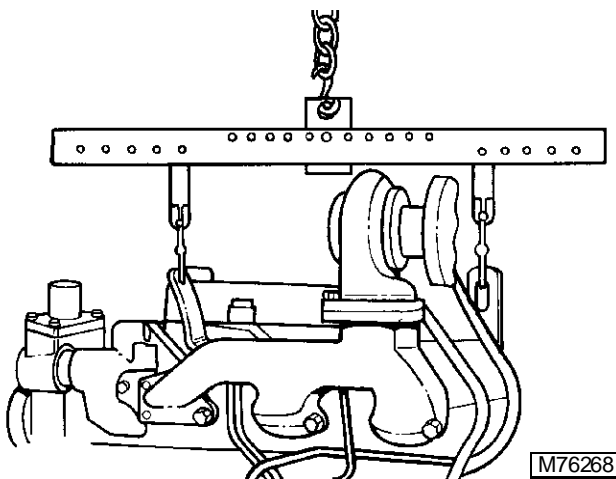

**Installing Adapter Plate To Engine Stand**

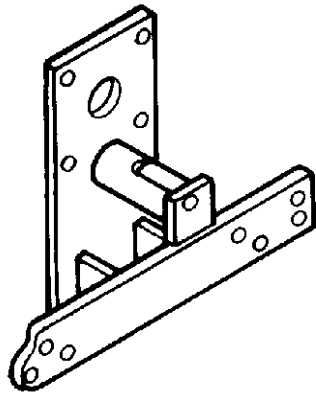

RG4737

1. Attach the D05225ST Engine Adapter Plate to mounting hub of the engine repair stand using four 5/8-11 x 2in. SAE Grade 8 cap screws. Tighten screws to 135 N•m (100 lb-ft).

**IMPORTANT:** When servicing turbocharged engine on rollover stand, disconnect turbocharger oil inlet line before rolling engine over. Failure to do so may cause severe engine damage from hydraulic lock upon starting engine. Hydraulic lock occurs when trapped oil in the oil filter housing drains through the turbocharger, into exhaust and intake manifolds, and cylinder head. After starting the engine, trapped oil in the manifold and head is released into the cylinder(s) filling them with oil - causing hydraulic lock and severe engine damage.

4. Disconnect turbocharger oil inlet line at turbocharger.



**Mounting Engine On Repair Stand**

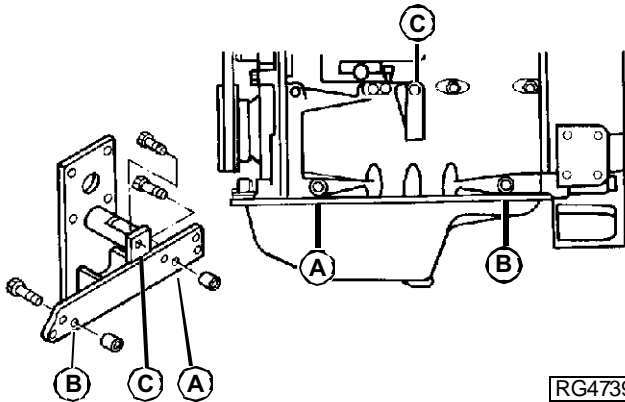

RG4739

1. Use No. 202557 Spacer (25mm O.D. x 73 mm long) at hole (A) and No. 202558 Spacer (25mm O.D. x 79 mm long) at hole (B).

*NOTE: Spacers are furnished with the D05225ST Engine Adapter.*

2. Mount engine to adapter using the cap screws listed below at the hole locations as shown :  
 Hole A ..... 9/16-12 x 4-1/2 in.  
 Hole B ..... 9/16-12 x 4-1/2 in.  
 Hole C ..... 9/16-12 x 1-1/2 in.

3. Drain all engine oil and coolant .

## ENGINE DISASSEMBLY SEQUENCE

The following sequence is suggested when complete disassembly for overhaul is required. Refer to the appropriate repair group when removing individual engine components.

1. Drain coolant and oil. Check engine oil for metal contaminates.
2. Remove fan belts, fan and alternator.
3. Remove turbocharger and exhaust manifold.
4. Remove rocker arm cover and vent tube.
5. Remove water manifold / thermostat housing.
6. Remove oil cooler piping, and water pump.
7. Remove dipstick, oil filter, oil cooler. Discard standard-flow oil cooler if oil is contaminated.
8. Remove oil pressure regulating valve assembly.
9. Remove fuel filter, fuel supply pump, and fuel line.
10. Remove injection lines, injection pump, and injection nozzles.
11. Remove starting motor.
12. Remove rocker arm assembly and push rods. Keep rods in order. Check for bent push rods and condition of wear pad contact surfaces on rockers.
13. Remove cylinder head. Check piston protrusion. Verify piston height selection.
14. Remove cam followers. Keep followers in order.
15. Remove flywheel and flywheel housing.
16. Remove oil pan.
17. Remove crankshaft pulley.
18. Remove timing gear cover.
19. Remove oil pump drive gear, outlet tube, and pump body.
20. Remove oil slinger, timing gears, and camshaft. Perform wear checks.
21. Remove balancer shafts.
22. Remove engine front plate.
23. Remove oil bypass valve.
24. Stamp cylinder number on connecting rod. Remove pistons and rods. Perform wear checks with PLASTIGAGE<sup>®</sup>.
25. Remove crankshaft and main bearings. Perform wear checks with PLASTIGAGE<sup>®</sup>.
26. Remove cylinder liners and mark each one with cylinder number and position in block.
27. Remove piston cooling orifices.
28. Remove camshaft bushing.
29. Remove cylinder block plugs and serial number plate when block is to hot tanked.
30. Clean upper and lower liner bores with nylon brush.
31. Measure cylinder block.



## ENGINE ASSEMBLY SEQUENCE

The following assembly sequence is suggested when engine has been completely disassembled. Be sure to check runout specifications, clearance tolerances, torques, etc. as engine is assembled. Refer to the appropriate repair group when assembling engine components.

1. Install all plugs and serial number plate in cylinder block (if removed).
2. Install piston cooling orifices.
3. Install new balancer shaft bushings and a new camshaft bushing (if equipped).
4. Install cylinder liners without O-rings. Measure liner height. Install liners with O-rings.
5. Install main bearing and crankshaft. Plastigage bearings.
6. Install flywheel housing, rear oil seal, and flywheel.
7. Install pistons and rods. Measure piston protrusion.
8. Install oil bypass valve.
9. Install front plate.
10. Install oil outlet tube, O-ring in block, and oil pump.
11. Install injection pump.
12. Install camshaft, timing gears, and oil slinger.
13. Time all gears with No. 1 cylinder at TDC compression stroke.
14. Install timing gear cover. Install new front seal.
15. Install oil pan.
16. Install oil pressure regulating valve.
17. Install cam followers in same order as removed.
18. Install cylinder head gasket, cylinder head, push rods, and rocker arm assembly.
19. Install starting motor.
20. Install injection nozzles (with new seals) and injection lines.
21. Install fuel filter, fuel supply pump, and fuel lines.
22. Install oil cooler, new oil filter, and dipstick. (Never clean or reuse a contaminated oil cooler.)
23. Install water manifold / thermostat housing, and thermostat.
24. Install exhaust manifold and turbocharger. Prelube the turbocharger.
25. Install water pump and hoses.
26. Install crankshaft pulley.
27. Install alternator, fan, and fan belts.
28. Adjust valves and install rocker arm cover.
29. Install vent tube.
30. Fill engine with clean oil and proper coolant.
31. Perform engine break-in and performance checks.



**Suggest:**

**If the above button click is invalid.**

**Please download this document**

**first, and then click the above link**

**to download the complete manual.**

**Thank you so much for reading**

## CYLINDER HEAD REPAIR

### CYLINDER HEAD REMOVAL

In some applications, it may be necessary to remove engine from machine to service cylinder head. Refer to Engine Removal Section for procedure .

## C CAUTION

Hot exhaust system components can cause serious burns. After operating engine, allow exhaust system to cool before working on engine.

Explosive release of fluids from pressurized cooling system can cause serious burns. Shut off engine. Remove radiator filler cap only when the cap is cool enough to touch with bare hands. Slowly loosen cap to first stop to relieve pressure before removing completely.

1. Drain all engine oil and coolant .
2. Remove air inlet adapter and intake manifold .
3. Disconnect turbocharger oil inlet and outlet lines .
4. Remove turbocharger and exhaust manifold as an assembly .
5. Remove thermostat housing/water manifold
6. Remove air cleaner, fuel filter, and air cleaner bracket assembly .

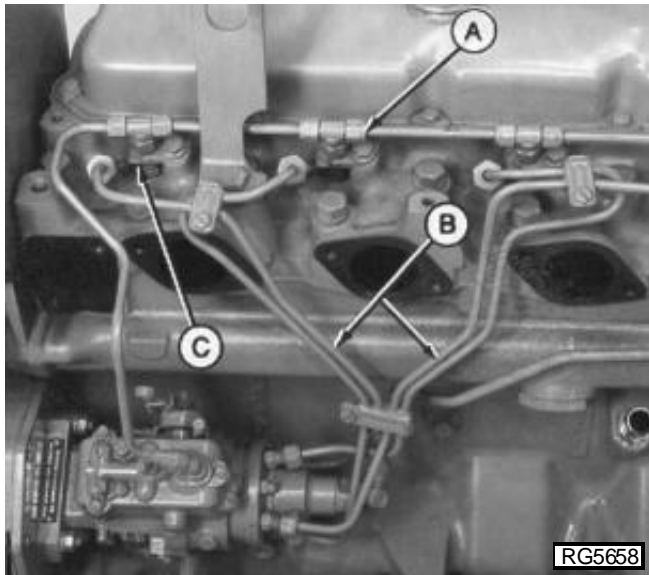

7. Remove fuel leakoff line (A) and fuel delivery lines (B) as an assembly. Remove fuel injection nozzles (C). (See *Fuel Repair* Section.)

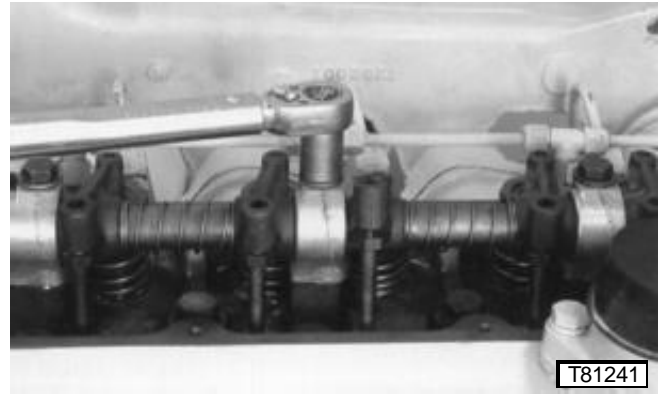

8. Remove rocker arm assembly .
9. Remove all push rods and identify for reassembly in the same location .

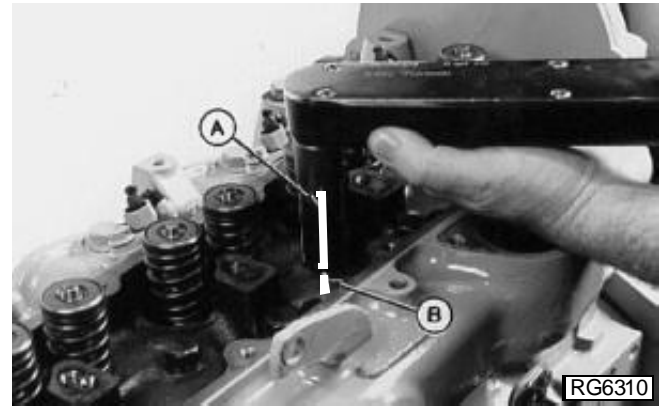

10. If a cylinder head gasket failure has occurred, check and record torque on each cylinder head cap screw before removing .
11. Make a reference mark (in-line) on socket (A) and cylinder head surface (B). Loosen cap screw at least 1/2 turn. Retighten cap screw (using a torque wrench) until reference marks align and record torque .
12. Remove all cylinder head cap screws .

**IMPORTANT: Screwdrivers or prybars can damage cylinder head and block gasket surfaces. DO NOT use screwdrivers or prybars between cylinder block and head to loosen head gasket seal.**

**<https://www.ebooklibonline.com>**

Hello dear friend!

Thank you very much for reading.

Enter the link into your browser.

The full manual is available for immediate download.

**<https://www.ebooklibonline.com>**