

# 8450, 8650 and 8850 Tractor



JOHN DEERE

## TECHNICAL MANUAL

8450, 8650 and  
8850 Tractor

TM1256 (01APR85) English

John Deere Tractor Work  
TM1256 (01APR85)

LITHO IN U.S.A.  
ENGLISH



# 8450,8650 AND 8850 TRACTORS TECHNICAL MANUAL TM-1256 (APR-85)

## CONTENTS—OPERATION AND TESTS

*This manual covers Tractor Operation and Tests (yellow tabs).  
Repair (green tabs) are covered in TM-1254 (8850) and TM-1255 (8450/8650).*

### SECTION 210—GENERAL

Introduction and Safety Information

### SECTION 220—8450/8650 ENGINE OPERATION AND TESTS

Group 00—Specification and Special Tools  
Group 05—System Operation  
Group 10—System Tests and Diagnosis

### SECTION 225—8850 ENGINE OPERATION AND TESTS

Group 00—Specifications and Special Tools  
Group 05—System Operation  
Group 10—System Tests and Diagnosis

### SECTION 230—FUEL/AIR OPERATION AND TESTS

Group 00—Specifications and Special Tools  
Group 05—Air Intake System  
Group 10—Diesel Fuel System  
Group 15—Control Linkage

### SECTION 240—ELECTRICAL OPERATION AND TESTS

Group 00—Specifications and Special Tools  
Group 05—Electrical System Information  
Group 06—Phase I Wiring Diagrams  
Group 07—Phase II Wiring Diagrams  
Group 08—Phase III Wiring Diagrams  
Group 10—Electrical System Diagnosis  
Group 15—Charging Circuit Operation  
Group 20—John Deere Starting Circuit  
Group 21—Delco-Remy Starting Circuit  
Group 25—Lighting Circuit  
Group 30—INVESTIGATOR™ II Warning System  
Group 35—Accessory Circuits  
Group 40—Remote Electrical Circuits

### SECTION 250—POWER TRAIN OPERATION AND TESTS

Group 00—Specifications and Special Tools  
Group 05—PERMA-CLUTCH™ Operation and  
Lubrication  
Group 10—QUAD-RANGE™ Planetary Operation  
Group 15—QUAD-RANGE™ Eight-Speed Opera-  
tion  
Group 20—Transmission Operation and Lubrica-  
tion Circuits  
Group 25—Independent PTO Operation  
Group 30—Torque Divider and Drive Shafts  
Group 35—Differential and Final Drive Operation  
Group 40—Power Train Tests

### SECTION 260—STEERING/BRAKES OPERATION AND TESTS

Group 00—Specifications and Special Tools  
Group 05—Power Steering System Operation  
Group 10—Steering Metering Pump Operation  
Group 15—Steering Valve Operation  
Group 20—Steering and Feedback Cylinders  
Operation  
Group 25—Steering System Tests and Diagnosis  
Group 30—Power Brake System Operation  
Group 35—Brake Valve and Break Accumulator  
Operation  
Group 40—Brake Pistons, Plates and Disks  
Operation  
Group 45—Brake System Tests and Diagnosis

*Continued on next page*

*All information, illustrations and specifications contained in this technical manual are based on the latest information available at the time of publication. The right is reserved to make changes at any time without notice.*

COPYRIGHT® 1985  
DEERE & COMPANY  
Moline, Illinois  
All rights reserved  
A JOHN DEERE ILLUSTRATION  
Previous Editions Copyright® 1982, 1983, 1984  
DEERE & COMPANY

20U;210GEN AX1 280585

## CONTENTS—OPERATION AND TESTS —CONTINUED

### SECTION 270—HYDRAULIC OPERATION AND TESTS

- Group 00—Specifications and Special Tools
- Group 05—Hydraulic System Operation
- Group 10—Triple Pump Assembly Operation and Tests
- Group 15—Charge Circuit Valves Operation and Tests
- Group 20—Main Hydraulic Pump Operation and Tests
- Group 25—HYDRACUSHIONED™ Seat Valve Operation and Tests
- Group 30—Pressure Control Valve Operation and Tests

- Group 35—Rockshaft System Operation and Tests
- Group 40—Selective Control Valve Operation and Tests
- Group 45—Remote Cylinder Operation and Tests
- Group 50—Hydraulic System Tests

### SECTION 290—OPERATOR STATION OPERATIONS AND TESTS

- Group 00—Specifications and Special Tools
- Group 05—Air Conditioning System Operation
- Group 10—Air Conditioning System Tests
- Group 15—Heating System Operation and Tests
- Group 20—HYDRACUSHIONED Seat

**<https://www.ebooklibonline.com>**

Hello dear friend!

Thank you very much for reading.

Enter the link into your browser.

The full manual is available for immediate download.

**<https://www.ebooklibonline.com>**

*Introduction and Safety Information*

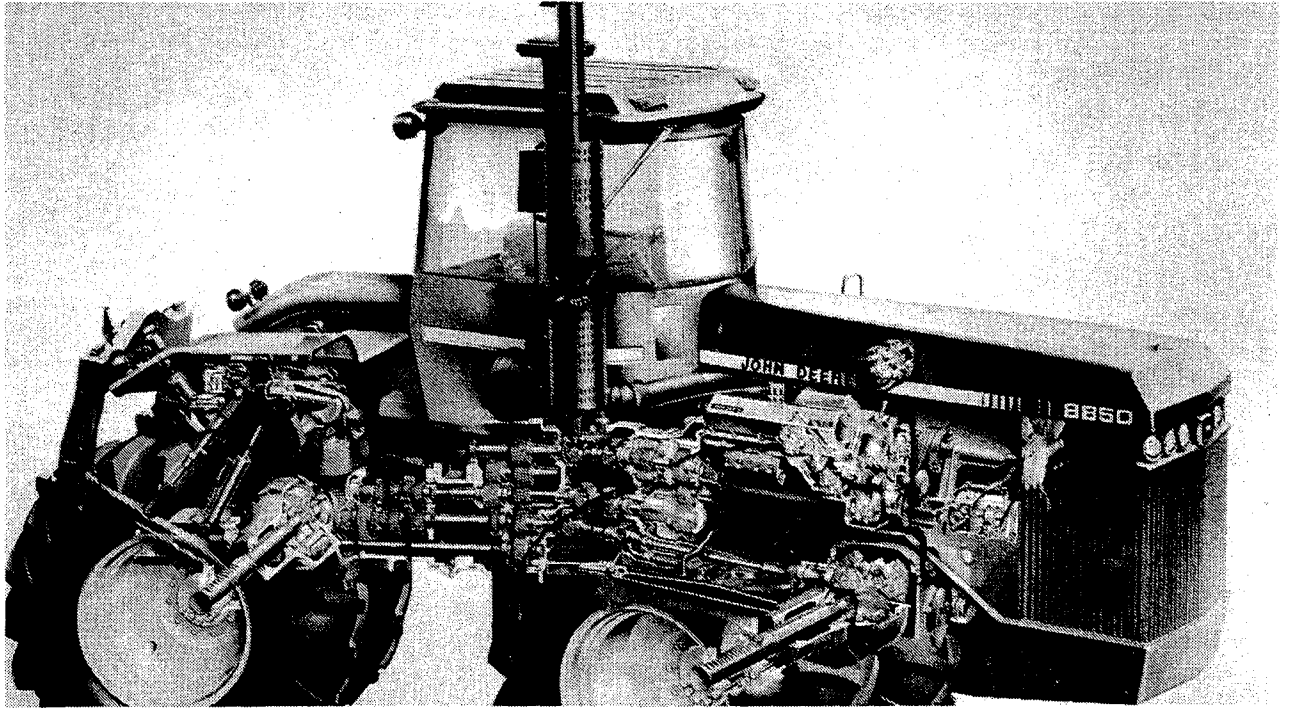

AC1R35385 20U210000 AX1 130182

## INTRODUCTION

This technical manual is part of a twin concept of service.

### FOS Manuals - for reference

### Technical Manuals - for actual service

The two kinds of manuals work as a team to give you both the general background and technical details of shop service.

*Fundamentals of Service (FOS) Manuals* cover basic theory of operation, fundamentals of troubleshooting, general maintenance, and basic types of failures and their causes. They are for training new personnel and for reference by experienced technicians.

*Technical Manuals* are concise service guides for specific machines. They are on-the-job guides containing the information needed by the service technician.

There are two technical manuals covering these machines:

- The repair manual, identified by green section tabs, and
- The operation and test manual, identified by yellow section tabs. These sections correspond respectively to the 2-digit repair sections.

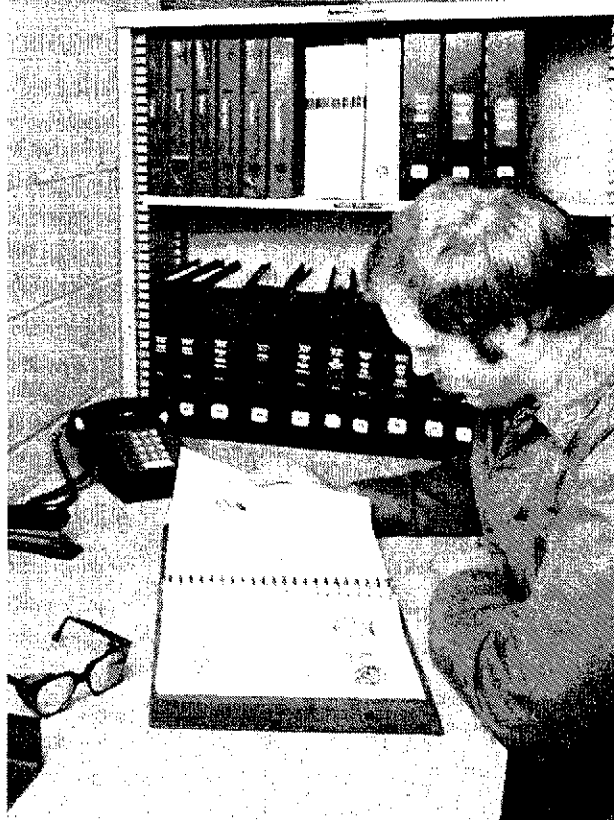

AC3:RW5559 U10;010INT A 301182

## FEATURES OF THIS TECHNICAL MANUAL

- John Deere ILLUSTRATION format emphasizing more detailed pictures and fewer words.
- Instructions and illustrations grouped together in easy-to-use modules.
- Testing and diagnosis groups in easy-to-follow step-by-step procedures.
- Operation stories and diagrams show how a system functions.

This technical manual was planned and written for you—an experienced service technician. Keep it in the shop where it is handy. Refer to it when you need to know correct service procedures or specifications.

Using the technical manual as a guide will reduce error and costly delay. It will also assure you the best in finished service work.



AC3:RW5560 U10;010INT V 090483

## SAFETY MESSAGES



This safety alert symbol and the word **CAUTION** identify important safety messages in this manual and on the tractor. When you see this symbol, be alert to the possibility of personal injury and carefully read the message that follows.

U10:0101NT C 101281

## IMPORTANT

The **IMPORTANT** message identifies potential problems which may cause consequential damage to the tractor. Following the recommended procedure will instruct the technician how to avoid the problem.

U10:0101NT D 101281

## NOTES

The word *NOTE* is followed by a statement that identifies a qualification or exception to a previous statement. A "NOTE" may also identify nice-to-know information pertinent to, but not directly related to the previous statement.

U10:0101NT E 101281

## KEEP RIDERS OFF MACHINE

Only allow the operator on the machine. Keep riders off.

Riders on a machine are subject to injury such as being struck by foreign objects and being thrown off of the machine. Riders also obstruct the operator's view resulting in the machine being operated in an unsafe manner.



AB6;TS173 053;RIDER 261184

## OPERATE TRACTOR SAFELY

Slow down for hillsides, rough ground, and sharp turns.

Always place transmission in PARK before dismounting. Leaving transmission in gear with engine stopped will NOT prevent the tractor from moving.

Keep all shields in place.

U01;SLOW DOWN 250285

## AVOID TIP-OVERS

Avoid holes, ditches, and obstructions which may cause the tractor to tip, especially on hillsides.

Never drive near the edge of a gully or steep embankment—it might cave in.

Be especially careful when using single wheels. Danger of an overturn increases greatly with narrow tread 80 in. (2.0 m) or less and high speed.

U01;TIP OVER 250285

## USE SEAT BELT PROPERLY

Use a seat belt when you operate with a roll-over protective structure (ROPS) to minimize chance of injury from an accident such as an overturn.

Do not use a seat belt if operating without a ROPS.

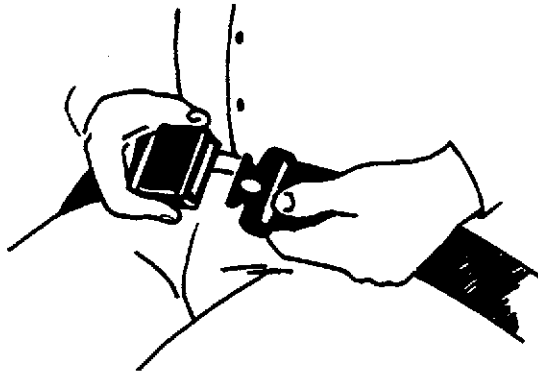

AB6;TS175 053;ROPS1 261184

### MAKE TRACTOR VISIBLE ON HIGHWAY

Turn light switch to "H" position. Never use white lights which are visible from the rear. Always dim head lamps before meeting another vehicle. Keep head lamps properly adjusted.

Add SMV emblem, reflectors, and auxiliary lighting to equipment as required for safety and by local regulations.

Before operating tractor on highway, be sure flashing warning lamps work properly. Adjust rear view mirror, and clean windows and SMV emblem.

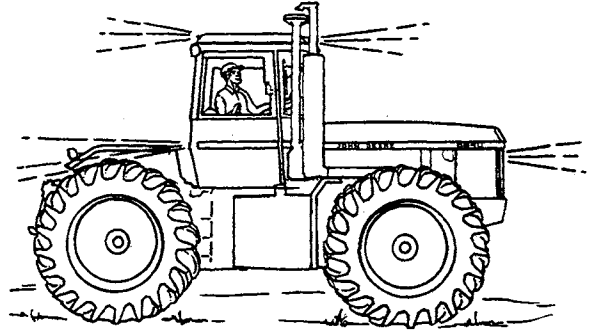

AJ7;RW4423 U01;SA06 X2 270284

### TRANSPORT TRACTOR SAFELY

Before descending a steep hill (A), shift to a low gear (B) to control the tractor with little or no braking. Never coast downhill.

When transporting on icy or graveled surfaces, be alert for skids which could result in loss of steering control. To decrease chance of skids, reduce speed and be sure tractor is properly ballasted.

Before towing tractor, see instruction in Transporting section. Never tow tractor faster than 5 mph (8 km/h) with all wheels on the ground. With rear wheels raised, never tow tractor faster than 10 mph (16 km/h).

Use of radial ply tires requires special precautions. (See Radial Ply Tires in Wheels, Tires and Treads section.)

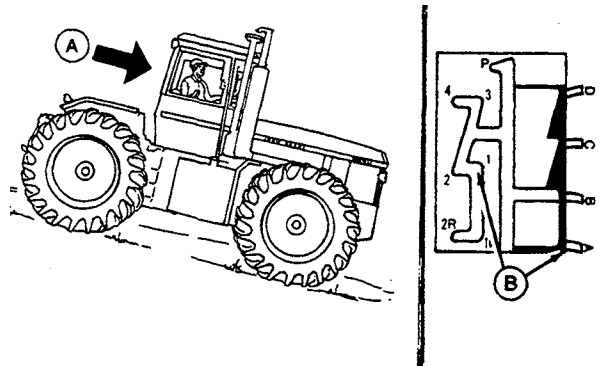

AJ7;RW4421 U01;SA04 X2 270284

### EMERGENCY EXIT

Make an emergency exit out the SOUND-GARD® body window by removing quick-lock pins (A) and headed pins (B) from window latches and pushing window wide open.

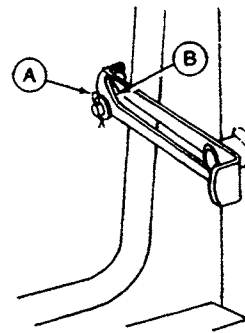

AJ7;RW4420 U01;EXIT 090585

## TOW EQUIPMENT PROPERLY

Use caution when towing loads at transport speeds. Reduce speed if towed load weighs more than the tractor and is not equipped with brakes. Avoid hard braking applications. (Consult implement operator's manual for recommended transport speeds.)

Use additional caution when transporting towed loads under adverse surface conditions, when turning, or on inclines.

U01:TOW 061284

## USE A SAFETY CHAIN

A safety chain will help control drawn equipment (B) should it accidentally separate from the drawbar (A) while transporting. Using the appropriate adapter parts, attach the chain to the tractor drawbar support or other specified anchor location. Provide only enough slack in the chain to permit turning. See your John Deere dealer for a chain with a strength rating equal to or greater than the gross weight of the towed machine.

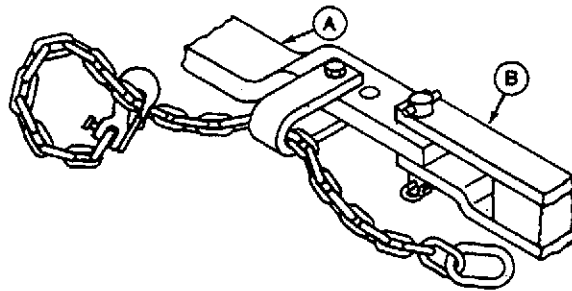

AB6:TS163 053:CHAIN 310684

## STAY CLEAR OF PTO

Stop the engine and be sure the PTO drive line has stopped before:

- Connecting or disconnecting implement drive line
- Making adjustments on the implement
- Cleaning out PTO driven equipment

PTO master shield (A) and drive line shields should be in place at all times except for special applications as directed in the implement operator's manual.

Install lock bars in tractor hinge before operating stationary PTO equipment. Be sure lock bars are removed before driving tractor.

Operate PTO at recommended speed.

Avoid loose-fitting or dangling clothing.

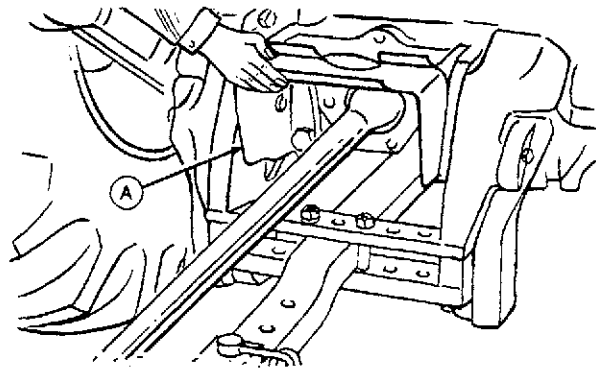

AJ7:RW4424 U01:PTO 1 250285

## OPERATE ON HILLSIDE SAFELY

Always operate tractor with dual wheels (A) except for width limitations when transporting. Avoid sharp uphill turns.

Keep transmission-hydraulic oil level at upper mark on dipstick (B) when operating on hillsides. Low oil level might result in loss of steering and clutch engagement. If this should happen, hold tractor with brakes, shift to PARK, stop engine, and add hydraulic oil to proper level.

Before operating on extremely steep slopes, overfill transmission-hydraulic system by 3.2 to 5.3 gal. (12 to 20 L). This is particularly important when using large hydraulic cylinders, due to the volume of oil used to extend them.

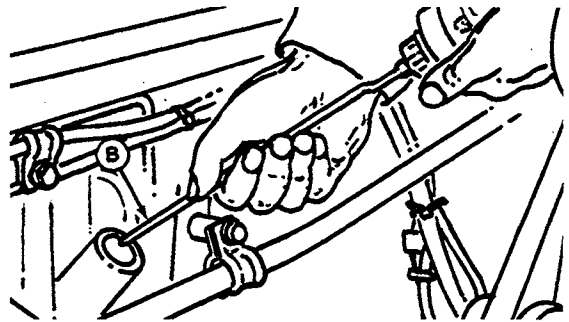
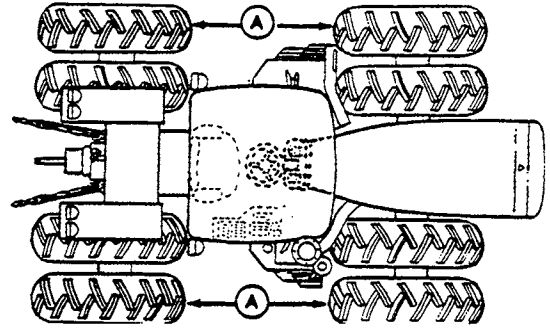

AJ7;RW8077,RW8071 U01:SA07 X2 270982

## STAY CLEAR OF MOVING TRACTOR

Be sure everyone is clear of tractor and attached equipment before starting engine or moving steering wheel. Tractor and equipment move (A), even with transmission in PARK. Some steering movement often occurs as engine starts.

Never try to get on or off a moving tractor.

Before dismounting, place the transmission in PARK and lower implements to the ground. If tractor is to be left unattended, stop the engine and remove the key.

Never attempt to start or operate tractor except from operator's station.

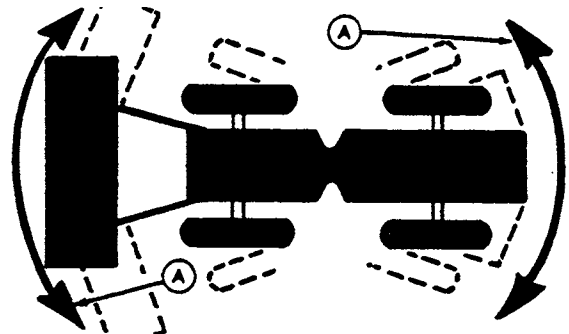

AJ7;RW8078 U01:SA10 X2 270982

## DO NOT MODIFY TRACTOR

Unauthorized modification to the machine may impair the function and/or safety and affect machine life.

Never modify structural members of SOUND-GARD body (A) by welding, bending, drilling or cutting as this might weaken the structure. If any structural member is damaged, replace the entire structure. Do not attempt repairs.

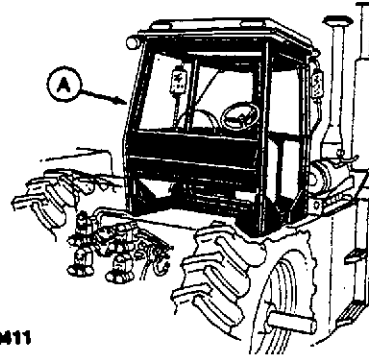

RW10411

AJ7;RW1041 1 U01;MODIFY 4WD 250585

## KEEP ROPS INSTALLED PROPERLY

Make certain all parts are reinstalled correctly if the roll-over protective structure (ROPS) is loosened or removed for any reason. Tighten mounting bolts to proper torque.

The protection offered by ROPS will be impaired if ROPS is subjected to structural damage, is involved in an overturn incident, or is in any way altered. A damaged ROPS should be replaced, not reused.

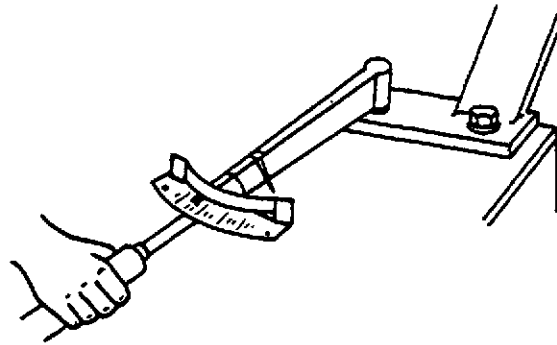

AB6;TS176 053;ROPS3 261184

## SERVICE TRACTOR SAFELY

Do not service the tractor while it is in motion or while the engine is running.

Stay clear of hinge area when engine is running. Stop engine and remove key before working near hinge.

Drive shaft does not turn at engine start-up until clutch pedal is depressed and released. Be aware of sudden rotation of drive shaft as clutch is actuated.

Install lock bars (A) on tractor hinge before performing service work in hinge area. Be sure lock bars are removed before operating tractor.

Disconnect the battery ground cable before working on the electrical system or working in any area when you might accidentally contact electrical components. A short circuit could cause burns as well as damaging the electrical system.

Reinstall all shields removed during service.

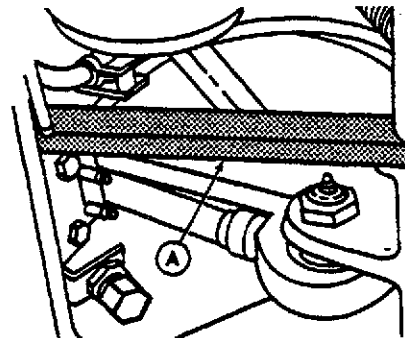

AC3;RW8506 U1C;0101NT AX2 210183

## PREVENT MACHINE RUNAWAY

Avoid possible injury or death from machinery runaway.

Do not start engine by shorting across starter terminals. Machine will start in gear if normal circuitry is bypassed.

NEVER start engine while standing on ground. Start engine only from operator's seat, with transmission in neutral or park.

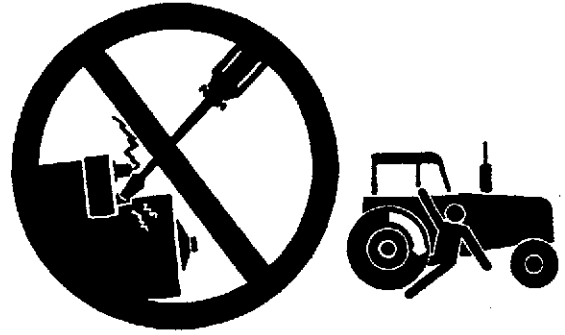

AB6;TS177 U01;BYPAS 1 250285

## AVOID HIGH-PRESSURE FLUIDS

Escaping fluid under pressure can penetrate the skin causing serious injury. Relieve pressure before disconnecting hydraulic or other lines. Tighten all connections before applying pressure. Keep hands and body away from pinholes and nozzles which eject fluids under high pressure. Use a piece of cardboard or paper to search for leaks.

If ANY fluid is injected into the skin, it must be surgically removed within a few hours by a doctor familiar with this type injury or gangrene may result.

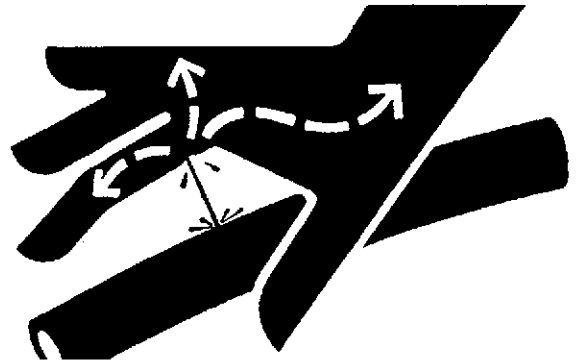

AB6;X9811 053;FLUID 100584

## AVOID EXPLOSIONS OR FIRE

Batteries produce explosive gas. Before using booster batteries, read instructions in operator's manual.

Before connecting or disconnecting battery charger, turn the charger off to avoid sparks. See instructions in operator's manual.

Be careful with starting fluid or any type fuel.

Never smoke while handling fuel.



AC3;RW5895 U10;AVOID FIRE 250285

## SERVICE BRAKE ACCUMULATOR SAFELY

Before disconnecting brake accumulator or brake valve, relieve all pressure from accumulator. To do so open bleed screws and pump brake pedal with engine stopped, until pedal easily goes all way down.

The accumulator is charged with dry nitrogen to a pressure of 500 psi (3450 kPa) (35 bar). If it needs recharging, have job done only by a qualified service person and only with dry nitrogen.

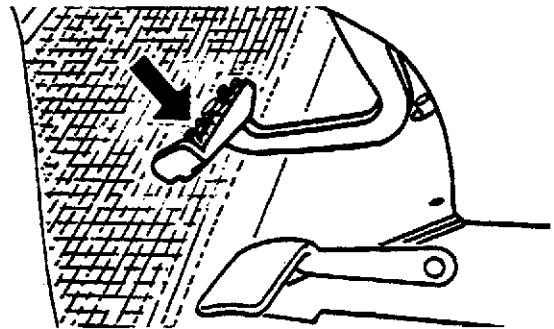

A;7;RW8103 U01;SA22 X2 161282

### OBSERVE ELECTRICAL SERVICE PRECAUTIONS

Keep all sparks and flames away from batteries, as gas given off by electrolyte is explosive. To avoid sparks, connect ground cable (A) last and disconnect it first. When using a booster battery, follow instructions in Operating the Engine section.

Disconnect battery ground cable before working in an area where you might accidentally contact electrical components causing shocks, burns, or damage to electrical system.

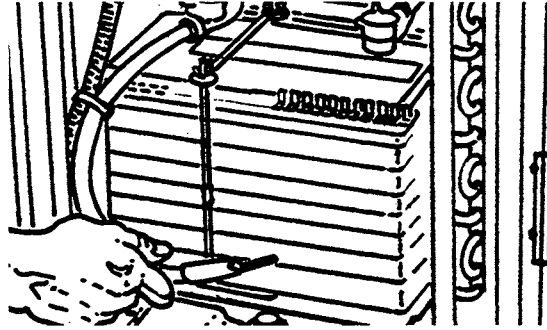

AJ7;RW8074 U01;SA19 X2 171282

### SERVICE COOLING SYSTEM SAFELY

Do not remove radiator cap (A) when engine is hot. Shut the engine off and wait until it cools. When removing cap, turn to the first stop to relieve pressure before removing it completely.

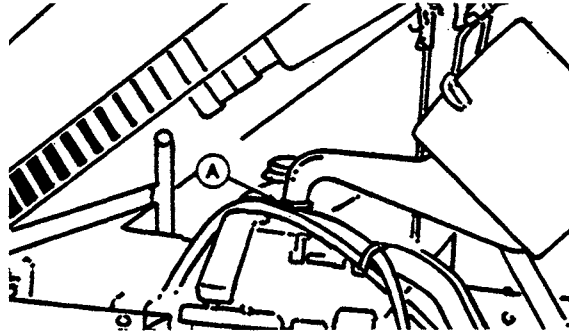

AJ7;RW8076 U01;SA21 X2 270982

### AVOID EXHAUST FUMES

Never run engine in a closed building. Make sure service area is adequately ventilated.

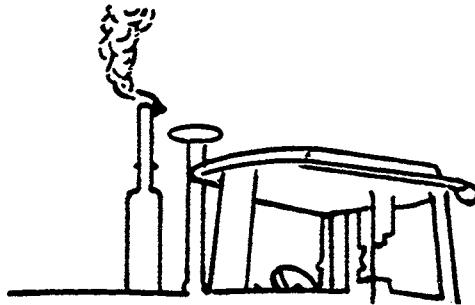

AJ7;RW8075 U01;FUMES 1 250285

### SERVICE TIRES SAFELY

Failure to follow proper procedures when mounting a tire on a wheel or rim can produce an explosion which may result in serious injury or death. Do not attempt to mount a tire unless you have the proper equipment and experience to perform the job.

When sealing tire beads on rims, never exceed 35 psi (241 kPa) (2.4 bar) or maximum inflation pressures specified by tire manufacturers for mounting tires. Inflation beyond this maximum pressure may break the bead, or even the rim, with dangerous explosive force. If both beads are not seated when the maximum recommended pressure is reached, deflate, reposition tire, relubricate bead and reinflate.

Detailed tire mounting instructions, including necessary safety precautions, are contained in John Deere Fundamentals of Service (FOS) Manual 55, Tires and Tracks. Such information is also available from the Rubber Manufacturers Association and from tire manufacturers.

- A—Use a Safety Cage if Available.
- B—Do Not Stand Over Tire. Use a Clip-on Chuck and Extension Hose.

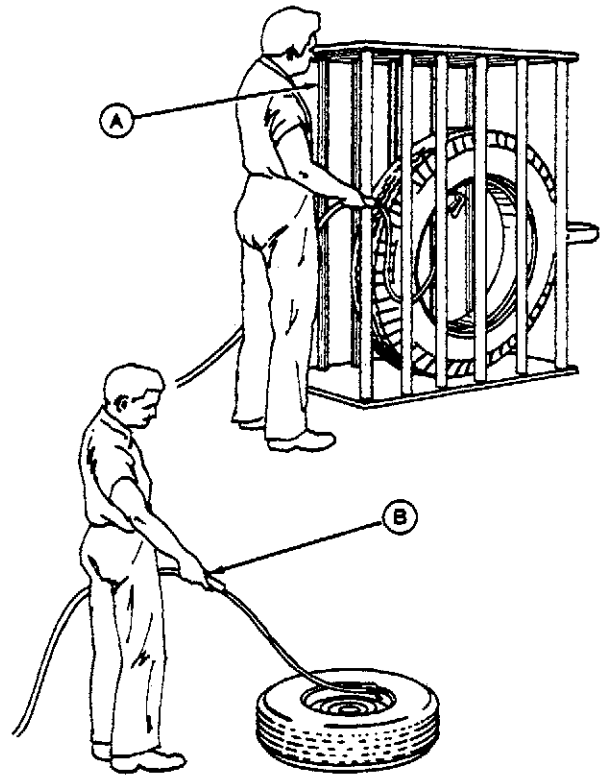

AB6;TS0123 U01;TIRE SAFE 250285

### HANDLE CHEMICALS PROPERLY

SOUND-GARD body air filters (A) are not designed to filter out harmful chemicals. Follow instructions given in the implement operator's manual and those given by the chemical manufacturer when using agricultural chemicals.

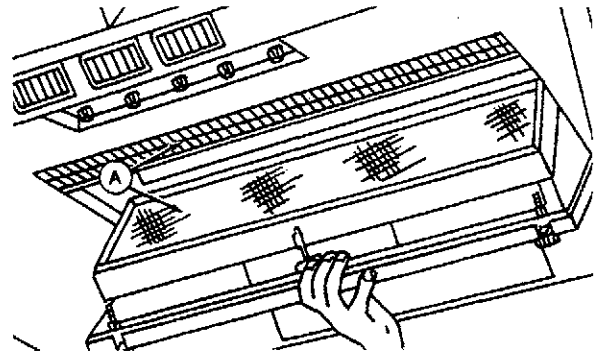

AJ7;RW5704L U01;HANDLE 2 311084

### PROTECT AGAINST NOISE

Prolonged exposure to loud noise can cause impairment or loss of hearing.

Wear a suitable hearing protective device such as earmuffs (A) or earplugs (B) to protect against objectionable or uncomfortable loud noises.

- A—Earmuffs
- B—Earplugs

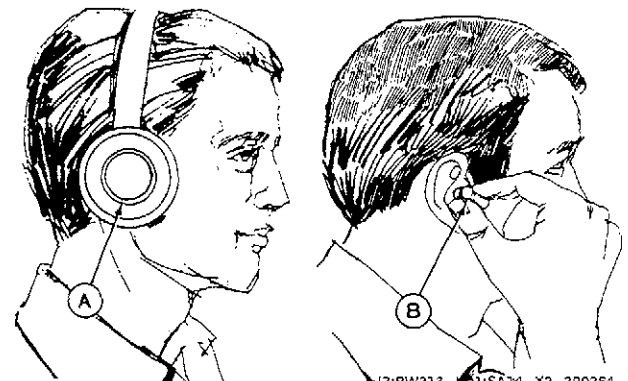

AJ7;RW213 U01;SA14 X2 290284



# Section 220 ENGINE OPERATION & TESTS

## CONTENTS

### GROUP 00 - SPECIFICATIONS AND SPECIAL TOOLS

Specifications .....	220-00-01
Special Tools .....	220-00-02

### GROUP 05 - SYSTEM OPERATION

Cooling System 6466A .....	220-05-01
Cooling System 6619A .....	220-05-02
How the 6466A Lubrication System Works .....	220-05-04
How the 6619A Lubrication System Works .....	220-05-05

### GROUP 10 - SYSTEM TESTS AND DIAGNOSIS

Dynamometer Test .....	220-10-01
Engine Break-In Instructions .....	220-10-01
Diagnosing Engine Malfunctions .....	220-10-02
Test 6466A and 6619A Compression Pressure .....	220-10-04
Check Valve Clearance (6466A and 6619A) .....	220-10-05
Check Valve Lift (6466A and 6619A) .....	220-10-07
Check Crankshaft End Play (6466A and 6619A) .....	220-10-07
Check Damper Run Out .....	220-10-08
Check Oil Pressure (6466A and 6619A) .....	220-10-08
Test Radiator and Cap .....	220-10-09



## SPECIFICATIONS AND SPECIAL TOOLS

## SPECIFICATIONS

ITEM	MEASUREMENT	SPECIFICATION
6466A Engine .....	Compression Pressure .....	2280-2550 kPa (22.8-25.5 bar) (330-370 psi)
6619A Engine .....	Compression Pressure .....	2280-2620 kPa (22.8-26.2 bar) (330-380 psi)
6466A and 6619A Engines @ 2100 rpm .....	Oil Pressure .....	280-350 kPa (2.8-3.8 bar) (40-55 psi)
Valves - 6466A .....	Lift (intake) .....	10.5-11.2 mm (0.412-0.442 in.)
	(exhaust) .....	10.5-11.3 mm (0.412-0.443 in.)
	Clearance (intake) .....	0.41-0.51 mm (0.016-0.020 in.)
	(exhaust) .....	0.66-0.76 mm (0.026-0.030 in.)
Valves - 6619A .....	Lift (intake) .....	12.83-13.59 mm (0.505-0.535 in.)
	(exhaust) .....	11.20-11.96 mm (0.441-0.471 in.)
	Clearance (intake) .....	0.33-0.43 mm (0.013-0.017 in.)
	(exhaust) .....	0.58-0.68 mm (0.023-0.027 in.)
Crankshaft - 6466A and 6619A Engines .....	End Play .....	0.0380-0.380 mm (0.00150-0.0150 in.)
	Maximum Serviceable End Play ..	0.380 mm (0.0150 in.)
Damper - 6466A and 6619A Engines .....	Radial Run Out (Max.) .....	1.0 mm (0.040 in.)

20U;220000 AX1 081282

Specifications and Special Tools

**SPECIAL TOOLS—6466A AND 6619A**

*NOTE: Order tools from your SERVICE-GARD Catalog, unless otherwise indicated.*

Motorite tester and adapter are used for testing compression.

A—D-14547BA Motorite Tester  
B—D-14557BA Adapter

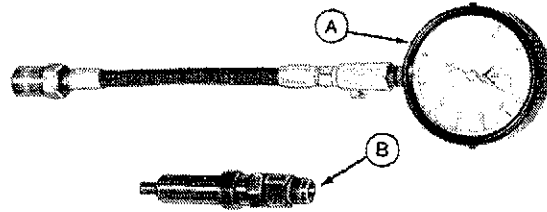

A87/R27489 S11:22000 F 290182

Used to remove and install KDEL nozzles.

JDE-92 Socket Wrench

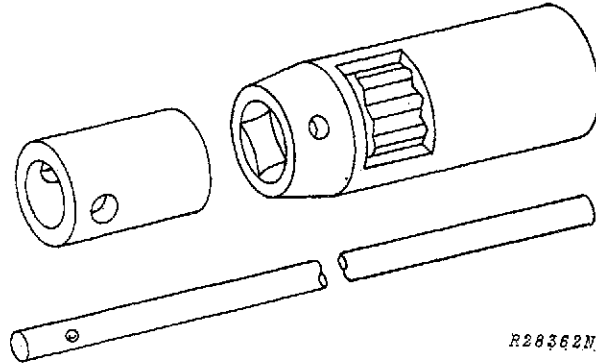

R28362N

A87/R28362 N S11:3000 O 220981

Used for testing oil pressure.



A—No. 0700 (D-1) Fitting  
B—No. 2106 (D-19HP) Hose and Fittings Assembly  
C—No. 2026 (D-20) Gauge

A87/R27490 S11:22000 C 081282

Turning tool is used to rotate flywheel when timing the engine.

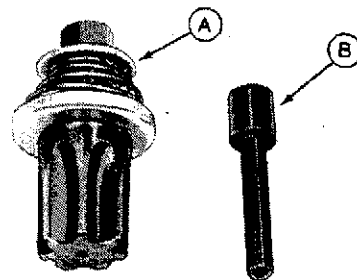

A—JDE-81-1 Flywheel Turning Tool  
B—JDE-81-4 Timing Pin

A87/R26134 S11:22000 D 041182

COOLING SYSTEM—6466A

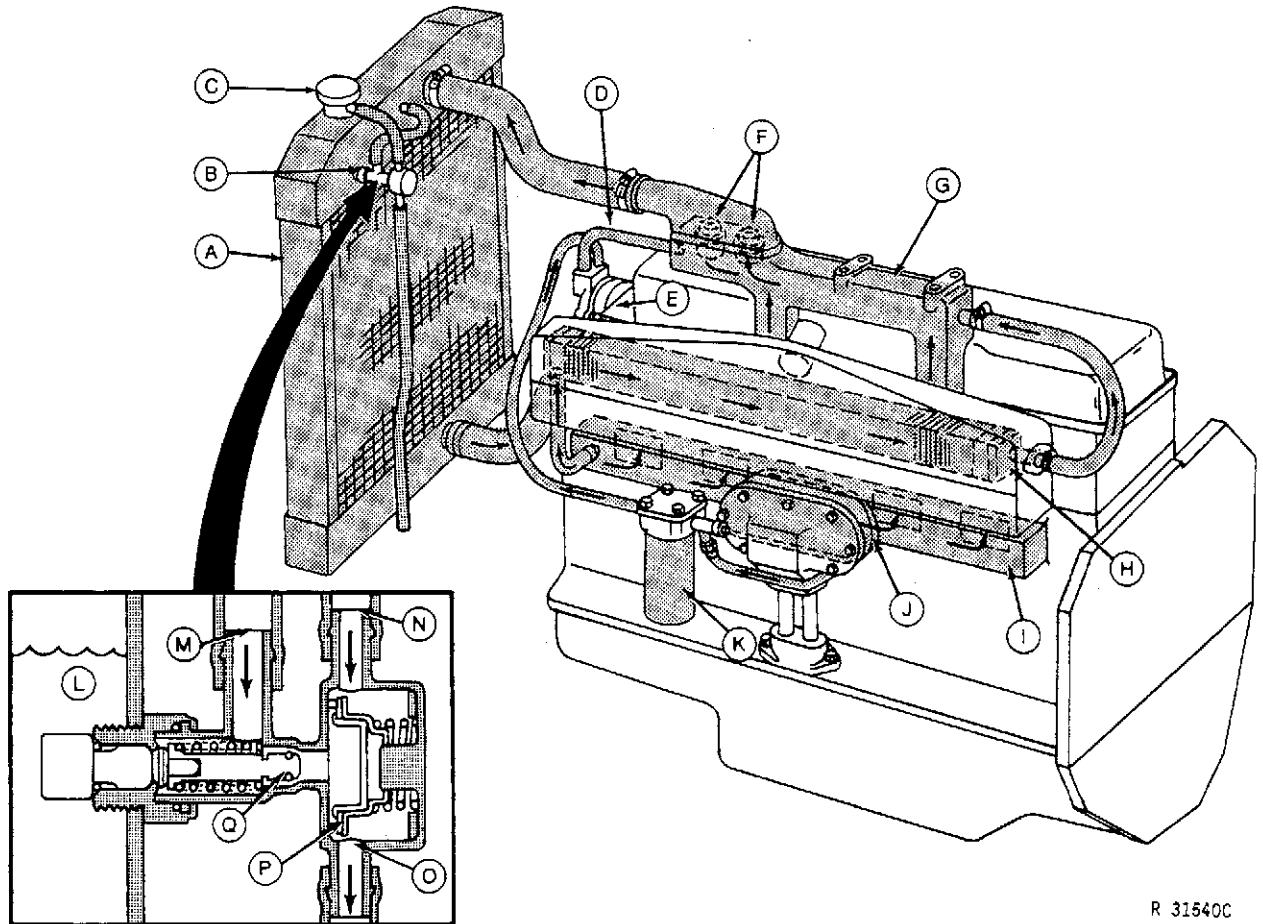

R 31540C

- A—Radiator
- B—Overflow Valve Housing
- C—Radiator Cap (15 psi) (1.03 bar)
- D—Coolant Bypass Pipe
- E—Water Pump
- F—Thermostats

- G—Water Manifold
- H—Intercooler
- I—Main Cooling Gallery
- J—Engine Oil Cooler
- K—Coolant Conditioner Filter
- L—Coolant

- M—Overflow from Top Tank
- N—Overflow from Radiator Cap
- O—Overflow to Ground
- P—Relief Valve
- Q—Overflow Valve

The dual pressure cooling system consists of a radiator (A), water pump (E), two thermostats (F), and water manifold (I).

*NOTE: Later model tractors use single pressure systems which do not have overflow valves. The 8650 Tractors use a 103 kPa (1 bar) (15 psi) pressurizing cap. The 8450 Tractors use a 48 kPa (.5 bar) (7 psi) pressurizing cap.*

A 103 kPa (1.03 bar) (15 psi) pressurizing cap (C) is connected by a hose to a coolant over flow valve (B) mounted at the rear of the radiator. A second hose connects the coolant overflow valve to the radiator top tank. Under normal conditions, relief valve (P) pres-

surizes extreme operating conditions (coolant temperatures of (105°C) 222°F and above) overflow valve (Q) closes stopping overflow from the radiator top tank (M). The 103 kPa (1.03 bar) (15 psi) cap (C) then pressurizes the system.

The pump draws coolant from the bottom of the radiator (A) and discharges it into the main coolant gallery (H) on the left-hand side of the engine. Coolant from the gallery circulates through the block to cool block and cylinder liners, then flows into the cylinder head. From the cylinder head, the coolant passes into the water manifold (G) and thermostat housing.

*Continued on next page*

AH3;R31540C 20U;220005 AX1 280585

### COOLING SYSTEM—6466A (Continued)

If the thermostats are closed (as during warm-up periods) coolant is directed back to the pump through the bypass pipe (D) to be recirculated. This provides a faster and more uniform warm-up.

If the thermostats are open (engine at normal operating temperature) coolant flows back through the thermostats to the top of the radiator.

Coolant is also taken from the main gallery into the intercooler (H) to cool intake air. It circulates through

the intercooler and out to the water manifold.

Additionally, coolant is drawn off the main gallery to the coolant conditioner filter (K). Here an anticorrosive chemical is added to the coolant while any debris that may be present in the cooling system is removed. The coolant returns to the system at the inlet side of the water pump.

The engine oil cooler (J), located in the main gallery, receives its cooling capacities from the coolant flow around it.

20U;220005 BX1 210182

### COOLING SYSTEM—6619A

The following refers to the illustration on the next page.

The dual pressure cooling system consists of a radiator (A), water pump (E), three thermostats (F), and water manifold (I).

*NOTE: Later tractors use a single pressure system which does not have an over flow valve. These tractors use a 103 kPa (1 bar) (15 psi) pressurizing cap.*

A 103 kPa (1.03 bar) (15 psi) pressurizing cap (C) is connected by a hose to a coolant overflow valve (B) mounted at the rear of the radiator. A second hose connects the coolant overflow valve to the radiator top tank. Under normal conditions, relief valve (P) pressurizes the system to 48 kPa (1.48 bar) (7 psi). Under extreme operating conditions (coolant temperatures of (105°C) 222°F and above), overflow valve (Q) closes stopping overflow from the radiator top tank (M). The 103 kPa (1.03 bar) (15 psi) cap (C) then pressurizes the system.

The pump draws coolant from the bottom of the radiator (A) and discharges it into the main coolant gallery (H) on the left-hand side of the engine. Coolant from the gallery circulates through the block to cool

block and cylinder liners, then flows into the cylinder head. From the cylinder head, the coolant passes into the water manifold (G) and thermostat housing.

If the thermostats are closed (as during warm-up periods) coolant is directed back to the pump through the bypass pipe (D) to be recirculated. This provides a faster and more uniform warm-up.

If the thermostats are open (engine at normal operating temperature) coolant flows back through the thermostats to the top of the radiator.

Coolant is also taken from the main gallery into the intercooler (H) to cool intake air. It circulates through the intercooler and out to the water manifold.

Additionally, coolant is drawn off the main gallery and routed through the coolant conditioner filter canister (K). Here an anticorrosive chemical is added to the coolant while any debris that may be present in the cooling system is removed. The coolant returns to the system at the inlet side of the water pump.

The engine oil cooler (J), mounted beneath the oil pressure regulating valve housing, receives coolant from the water pump and returns it to the cylinder block.

20U;220005 CX1 280585

**COOLING SYSTEM—6619A**

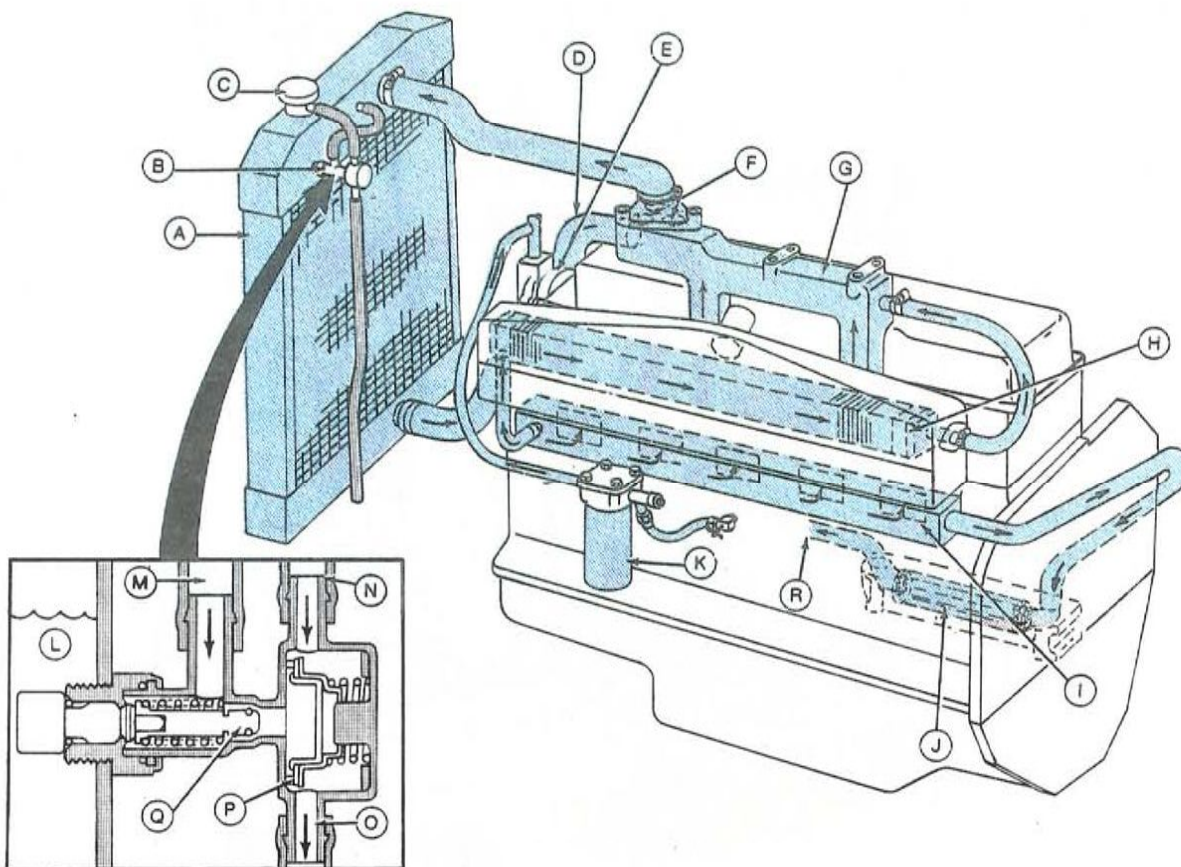

- A—Radiator
- B—Overflow Valve Housing
- C—Radiator Cap
- D—Coolant Bypass Pipe
- E—Water Pump
- F—Thermostats

- G—Water Manifold
- H—Intercooler
- I—Main Cooling Gallery
- J—Engine Oil Cooler
- K—Coolant Conditioner Filter
- L—Coolant

- M—Overflow from Top Tank
- N—Overflow from Radiator Cap
- O—Overflow to Ground
- P—Relief Valve
- Q—Overflow Valve
- R—To Water Pump

AH3:RG4366 20U:220005 DX1 081282

## HOW THE 6466A LUBRICATION SYSTEM WORKS

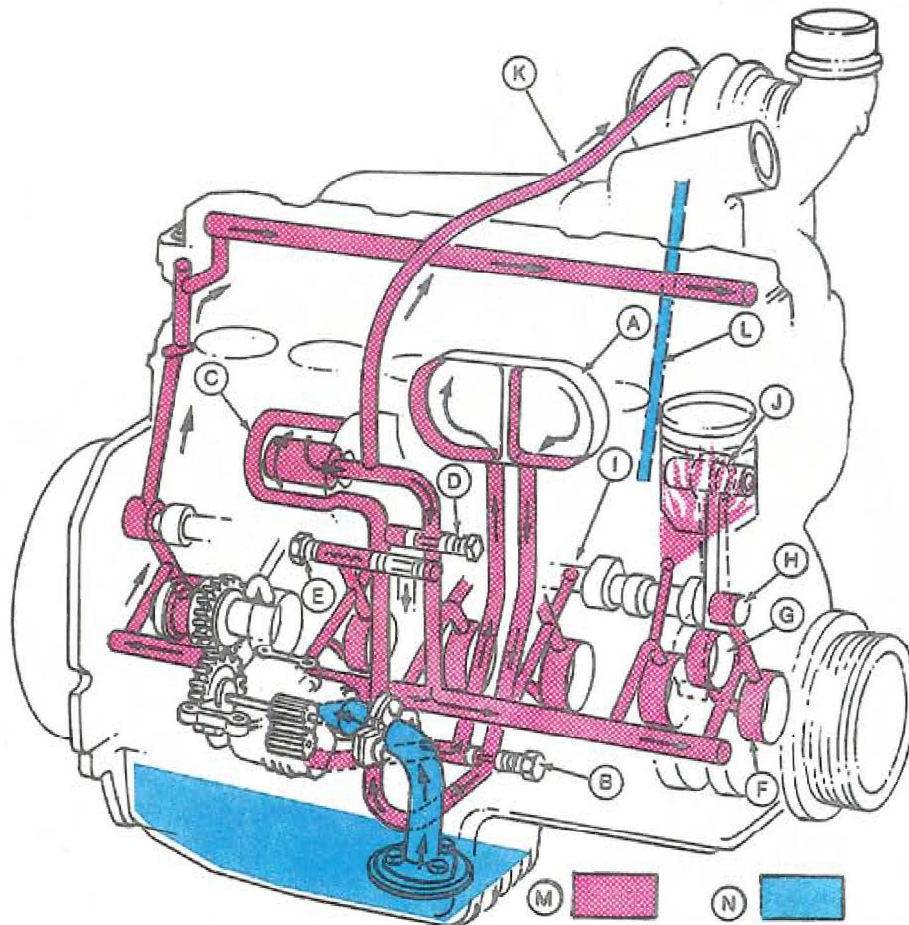

6466A Engine Lubrication System

- |                           |                                 |                               |                                |
|---------------------------|---------------------------------|-------------------------------|--------------------------------|
| A—Engine Oil Cooler       | E—Oil Pressure Regulating Valve | H—Camshaft Bushings           | L—Turbocharger Oil Return Tube |
| B—Oil Cooler Bypass Valve | F—Main Bearings                 | I—Piston Cooling Orifices     | M—Engine Oil Pressure          |
| C—Oil Filter              | G—Connecting Rod Bearings       | J—Piston Pin and Bushing      | N—Oil Pan Oil                  |
| D—Filter Bypass Valve     |                                 | K—Turbocharger Oil Inlet Line |                                |

The engine lubrication system consists of a gear-driven positive displacement pump, oil cooler, oil filter, cooler bypass valves, oil pressure regulating valve and filter bypass valve.

Oil is pumped from the oil pan by the engine oil pump through the engine oil cooler (A) around the oil cooler bypass valve (B) into the engine oil filter (C). Passing through the filter, the oil continues around the filter bypass valve (D) and in front of the engine oil pressure regulating valve (E) into the engine oil gallery in the cylinder block. Oil is then distributed, under pressure, to each main bearing (F) and piston cooling orifice (I).

Oil from the piston cooling orifices lubricates the piston pin and bushing (J) through a hole in the connecting rod.

Cross-drilled passages in the crankshaft distribute oil from the main bearing journals to the connecting rod journals to lubricate connecting rod bearings (G). Numbers 1, 3, 5, and 7 main bearing supports are also drilled to lubricate the four camshaft bushings (H). A drilled passage from the rear camshaft bushing through the cylinder block and cylinder head provides lubrication to the rocker arm shaft.



**Suggest:**

**If the above button click is invalid.**

**Please download this document**

**first, and then click the above link**

**to download the complete manual.**

**Thank you so much for reading**

## HOW THE 6619A LUBRICATION SYSTEM WORKS

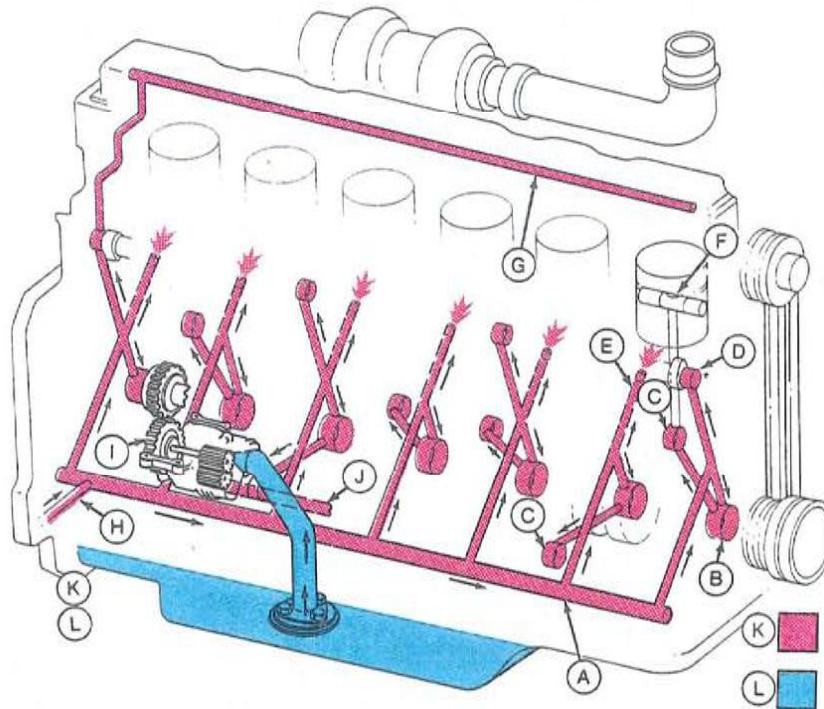

6619A Engine Lubrication System

- |                                    |                                    |  |   |
|------------------------------------|------------------------------------|--|---|
| A—Main Oil Gallery                 | E—Piston Cooling Orifices (6 used) | G—Rocker Arm Shaft                                 | J—Outlet to Oil Pressure Regulating Valve Housing |
| B—Main Bearings (7 used)           | F—Connecting Rod Bushings (6 used) | H—Inlet From Oil Pressure Regulating Valve Housing | K—Engine Oil Pressure                             |
| C—Connecting Rod Bearings (6 used) | D—Camshaft Bushings (4 used)       | I—Engine Oil Pump                                  | L—Oil Pan Oil                                     |

The engine lubrication system consists of a gear-driven positive displacement pump (I), an oil pressure regulating housing containing filter, filter relief valve, pressure regulating valve, oil cooler relief valve and an oil cooler.

Oil is pumped from the oil pan by the oil pump into the oil pressure regulating valve housing, the oil goes through the oil cooler and filter and into the main oil gallery (A) in the cylinder block. Oil is then distributed, under pressure, to each main bearing (B) and piston cooling orifice (E).

Drilled passages in the crankshaft distribute oil from the main bearing journals to the connecting rod journals to lubricate connecting rod bearings (C). Numbers 1, 3, 5, and 7 main bearing supports are also drilled to lubricate the four camshaft bushings (D). A drilled passage from the rear camshaft bushing through the cylinder block and cylinder head provides lubrication to the rocker arm shaft.

The piston cooling orifices (E) spray oil to cool pistons and liners and lubricate the connecting rod piston pin bushings through an oil cup in the top of the connecting rod.

**<https://www.ebooklibonline.com>**

Hello dear friend!

Thank you very much for reading.

Enter the link into your browser.

The full manual is available for immediate download.

**<https://www.ebooklibonline.com>**