

4475, 5575, 6675 & 7775 Skid Steer Loaders

Serial No. (010001 -)

TECHNICAL MANUAL

**John Deere
Lawn & Grounds Care Division
TM1553 (April 95)**

This technical manual is written for an experienced technician and contains sections that are specifically for this product. It is a part of a total product support program.

The manual is organized so that all the information on a particular system is kept together. The order of grouping is as follows:

- Table of Contents
- Specifications
- Theory of Operation
- Troubleshooting Diagram
- Diagnostics
- Tests & Adjustments
- Repair

Note: Depending on the particular section or system being covered, not all of the above groups may be used.

Each section will be identified with a symbol rather than a number. The groups and pages within a section will be consecutively numbered.

All information, illustrations and specifications in this manual are based on the latest information available at the time of publication. The right is reserved to make changes at any time without notice.

We appreciate your input on this manual. To help, there are postage paid post cards included at the back. If you find any errors or want to comment on the layout of the manual please fill out one of the cards and mail it back to us.

Safety



Specifications and Information



Engine (Diesel)



Electrical



Power Train



Power Train (Hydrostatic)



Steering



Brakes



Hydraulics



Backhoe



Miscellaneous

M

COPYRIGHT© 1995
JOHN DEERE HORICON WORKS
Horicon, Wisconsin
All rights reserved



HANDLE FLUIDS SAFELY-AVOID FIRES

- BE PREPARED FOR EMERGENCIES

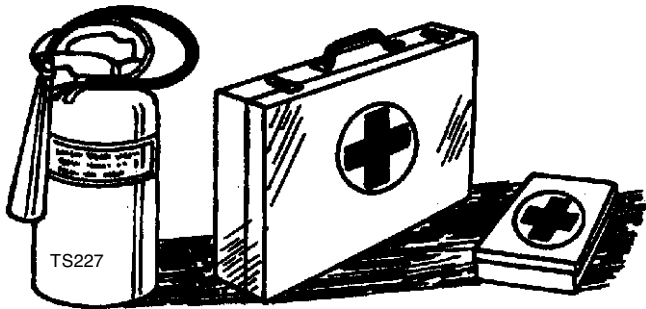

When you work around fuel, do not smoke or work near heaters or other fire hazards.

Store flammable fluids away from fire hazards. Do not incinerate or puncture pressurized containers.

Make sure machine is clean of trash, grease, and debris.

Do not store oily rags; they can ignite and burn spontaneously.

Be prepared if a fire starts.

Keep a first aid kit and fire extinguisher handy.

Keep emergency numbers for doctors, ambulance service, hospital, and fire department near your telephone.

HANDLE CHEMICAL PRODUCTS SAFELY

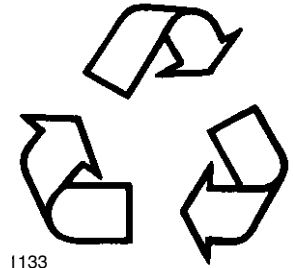

Direct exposure to hazardous chemicals can cause serious injury. Potentially hazardous chemicals used with John Deere equipment include such items as lubricants, coolants, paints, and adhesives.

A Material Safety Data Sheet (MSDS) provides specific details on chemical products: physical and health hazards, safety procedures, and emergency response techniques. Check the MSDS before you start any job using a hazardous chemical. That way you will know exactly what the risks are and how to do the job safely. Then follow procedures and recommended equipment.

- DISPOSE OF WASTE PROPERLY

Improperly disposing of waste can threaten the environment and ecology. Potentially harmful waste used with John Deere equipment include such items as oil, fuel, coolant, brake fluid, filters, and batteries. Use leakproof containers when draining fluids. Do not use food or beverage containers that may mislead someone into drinking from them. Do not pour waste onto the ground, down a drain, or into any water source. Inquire on the proper way to recycle or dispose of waste from your local environmental or recycling center, or from your John Deere dealer.

<https://www.ebooklibonline.com>

Hello dear friend!

Thank you very much for reading.

Enter the link into your browser.

The full manual is available for immediate download.

<https://www.ebooklibonline.com>

USE CARE AROUND HIGH-PRESSURE FLUID LINES

• AVOID HIGH-PRESSURE FLUIDS

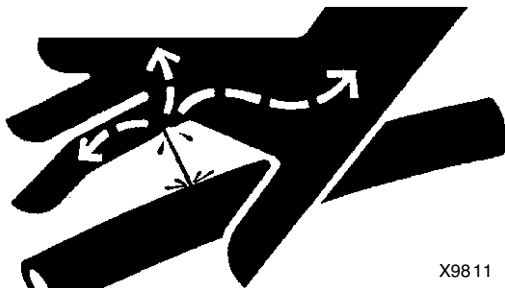

X9811

Escaping fluid under pressure can penetrate the skin causing serious injury.

Avoid the hazard by relieving pressure before disconnecting hydraulic or other lines. Tighten all connections before applying pressure.

Search for leaks with a piece of cardboard. Protect hands and body from high pressure fluids.

If an accident occurs, see a doctor immediately. Any fluid injected into the skin must be surgically removed within a few hours or gangrene may result. Doctors unfamiliar with this type of injury should reference a knowledgeable medical source. Such information is available from Deere & Company Medical Department in Moline, Illinois, U.S.A.

• AVOID HEATING NEAR PRESSURIZED FLUID LINES



TS953

Flammable spray can be generated by heating near pressurized fluid lines, resulting in severe burns to yourself and bystanders. Do not heat by welding, soldering, or using a torch near pressurized fluid lines or other flammable materials. Pressurized lines can be accidentally cut when heat goes beyond the immediate flame area.

USE CARE IN HANDLING AND SERVICING BATTERIES

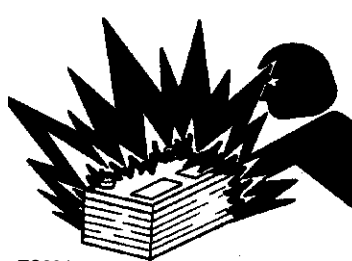

TS204

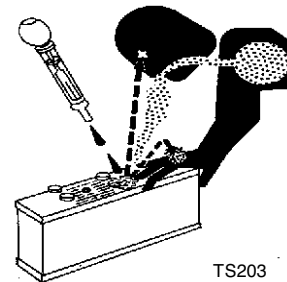

TS203

• PREVENT BATTERY EXPLOSIONS

- Keep sparks, lighted matches, and open flame away from the top of battery. Battery gas can explode.
- Never check battery charge by placing a metal object across the posts. Use a volt-meter or hydrometer.
- Do not charge a frozen battery; it may explode. Warm battery to 16°C (60°F).

• PREVENT ACID BURNS

- Sulfuric acid in battery electrolyte is poisonous. It is strong enough to burn skin, eat holes in clothing, and cause blindness if splashed into eyes.

• Avoid acid burns by:

1. Filling batteries in a well-ventilated area.
2. Wearing eye protection and rubber gloves.
3. Avoiding breathing fumes when electrolyte is added.
4. Avoiding spilling or dripping electrolyte.
5. Use proper jump start procedure.

• If you spill acid on yourself:

1. Flush your skin with water.
2. Apply baking soda or lime to help neutralize the acid.
3. Flush your eyes with water for 10_15 minutes.
4. Get medical attention immediately.

• If acid is swallowed:

1. Drink large amounts of water or milk.
2. Then drink milk of magnesia, beaten eggs, or vegetable oil.
3. Get medical attention immediately.



USE SAFE SERVICE PROCEDURES

• WEAR PROTECTIVE CLOTHING

Wear close fitting clothing and safety equipment appropriate to the job.

Prolonged exposure to loud noise can cause impairment or loss of hearing. Wear a suitable hearing protective device such as earmuffs or earplugs to protect against objectionable or uncomfortable loud noises.

Operating equipment safely requires the full attention of the operator. Do not wear radio or music headphones while operating machine.

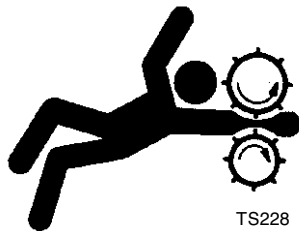
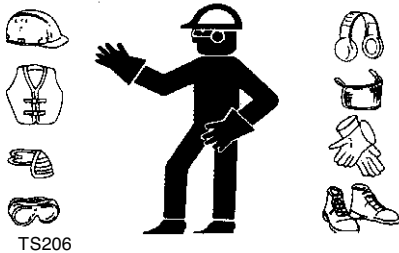

• SERVICE MACHINES SAFELY

Tie long hair behind your head. Do not wear a necktie, scarf, loose clothing, or necklace when you work near machine tools or moving parts. If these items were to get caught, severe injury could result.

Remove rings and other jewelry to prevent electrical shorts and entanglement in moving parts.

• USE PROPER TOOLS

Use tools appropriate to the work. Makeshift tools and procedures can create safety hazards. Use power tools only to loosen threaded parts and fasteners. For loosening and tightening hardware, use the correct size tools. **DO NOT** use U.S. measurement tools on metric fasteners. Avoid bodily injury caused by slipping wrenches. Use only service parts meeting John Deere specifications.

• PARK MACHINE SAFELY

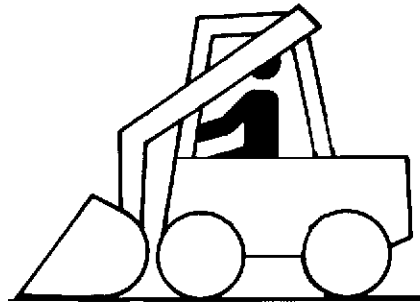

• Before working on the machine:

1. Lower all equipment to the ground.
2. Stop the engine and remove the key.
3. Disconnect the battery ground strap.
4. Hang a "DO NOT OPERATE" tag in operator station.

• SUPPORT MACHINE PROPERLY AND USE PROPER LIFTING EQUIPMENT

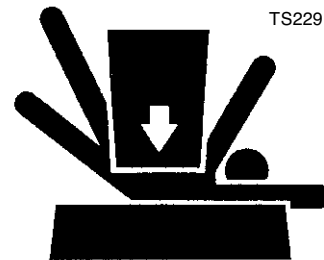

If you must work on a lifted machine or attachment, securely support the machine or attachment.

Do not support the machine on cinder blocks, hollow tiles, or props that may crumble under continuous load. Do not work under a machine that is supported solely by a jack. Follow recommended procedures in this manual.

Lifting heavy components incorrectly can cause severe injury or machine damage. Follow recommended procedure for removal and installation of components in the manual.

- **WORK IN CLEAN AREA**

- **Before starting a job**

1. Clean work area and machine:
2. Make sure you have all necessary tools to do your job.
3. Have the right parts on hand.
4. Read all instructions thoroughly; do not attempt shortcuts.

- **ILLUMINATE WORK AREA SAFELY**

Illuminate your work area adequately but safely. Use a portable safety light for working inside or under the machine. Make sure the bulb is enclosed by a wire cage. The hot filament of an accidentally broken bulb can ignite spilled fuel or oil.

- **WORK IN VENTILATED AREA**

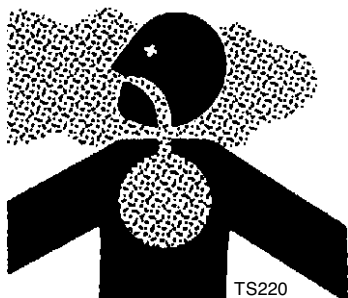

Engine exhaust fumes can cause sickness or death. If it is necessary to run an engine in an enclosed area, remove the exhaust fumes from the area with an exhaust pipe extension.

If you do not have an exhaust pipe extension, open the doors and get outside air into the area.

- **REMOVE PAINT BEFORE WELDING OR HEATING**

Avoid potentially toxic fumes and dust. Hazardous fumes can be generated when paint is heated by welding, soldering, or using a torch. Do all work outside or in a well ventilated area. Dispose of paint and solvent properly. Remove paint before welding or heating: If you sand or grind paint, avoid breathing the dust. Wear an approved respirator. If you use solvent or paint stripper, remove stripper with soap and water before welding. Remove solvent or paint stripper containers and other flammable material from area. Allow fumes to disperse at least 15 minutes before welding or heating.

- **AVOID HARMFUL ASBESTOS DUST**

:Avoid breathing dust that may be generated when handling components containing asbestos fibers. Inhaled asbestos fibers may cause lung cancer.

Components in products that may contain asbestos fibers are brake pads, brake band and lining assemblies, clutch plates, and some gaskets. The asbestos used in these components is usually found in a resin or sealed in some way. Normal handling is not hazardous as long as airborne dust containing asbestos is not generated.

Avoid creating dust. Never use compressed air for cleaning. Avoid brushing or grinding material containing asbestos. When servicing, wear an approved respirator. A special vacuum cleaner is recommended to clean asbestos. If not available, apply a mist of oil or water on the material containing asbestos. Keep bystanders away from the area.



- **SERVICE TIRES SAFELY**



Explosive separation of a tire and rim parts can cause serious injury or death.

Do not attempt to mount a tire unless you have the proper equipment and experience to perform the job. Always maintain the correct tire pressure. Do not inflate the tires above the recommended pressure. Never weld or heat a wheel and tire assembly. The heat can cause an increase in air pressure resulting in a tire explosion. Welding can structurally weaken or deform the wheel.

When inflating tires, use a clip-on chuck and extension hose long enough to allow you to stand to one side and NOT in front of or over the tire assembly. Use a safety cage if available.

- **Check wheels for low pressure, cuts, bubbles, damaged rims or missing lug bolts and nuts.**



REPLACE SAFETY SIGNS

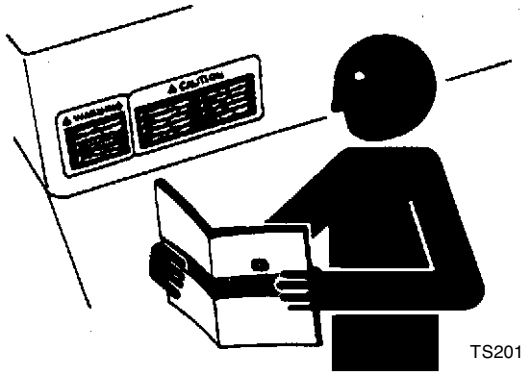

TS201

Replace missing or damaged safety signs. See the machine operator's manual for correct safety sign placement.

LIVE WITH SAFETY

TS231



Before returning machine to customer, make sure machine is functioning properly, especially the safety systems. Install all guards and shields.

CONTENTS

Page



SPECIFICATIONS & INFORMATION

GENERAL VEHICLE SPECIFICATIONS	2
UNIFIED INCH TORQUE VALUES	7
METRIC TORQUE VALUES	8
DIESEL FUEL SPECIFICATIONS	9
DIESEL FUEL STORAGE	9
LUBRICANT SPECIFICATIONS	10
ENGINE OIL	10
GREASE	10
TRANSMISSION AND HYDRAULIC OIL	11
CHAIN CASE OIL	11
GEARBOX OIL	11
ALTERNATIVE LUBRICANTS	11
SYNTHETIC LUBRICANTS	11
OIL FILTERS	11
LUBRICANT STORAGE	11
ENGINE COOLANT	12
SERIAL NUMBER LOCATION	12
SKID STEER LOADER PRODUCT IDENTIFICATION NUMBER	12
ENGINE SERIAL NUMBER	12

GENERAL VEHICLE SPECIFICATIONS



	4475	5575
ENGINE^a		
Make	John Deere Series 220	John Deere Series 220
Model	3015D001	3017D001
Type	Diesel	Diesel
Cylinders	3	3
Bore	84 mm (3.31 in.)	88 mm (3.46 in.)
Stroke	90 mm (3.54 in.)	90 mm (3.54 in.)
Displacement	1.5 L (91.3 cu. in.)	1.642 L (100.1 cu. in.)
Net horsepower	23 kW (31 hp) @ 3000 rpm	27.3 kW (36.6 hp) @ 3000 rpm
RPM, slow (no load)	900-1000	900-1000
RPM, fast (no load)	3125-3175	3125-3175
Lubrication	Full pressure	Full pressure
Crankcase capacity (with filter)	7.3 L (7.7 qt.)	7.3 L (7.7 qts.)
Cooling system	Liquid	Liquid
Coolant capacity radiator and block	10.3 L (10.8 qt.)	10.3 L (10.8 qt.)
Air filter type	Dry paper with primary and secondary elements	Dry paper with primary and secondary elements
ELECTRICAL		
Type of starter	Solenoid shift	Solenoid Shift
Battery voltage	12 Vdc	12 Vdc
Battery reserve capacity at 27°C (80° F)	160 minutes	160 minutes
Battery cold cranking amps at -18°C (0°F)	625	625
Charging system	40 amp alternator	40 amp alternator
FUEL SYSTEM		
Fuel	Diesel #1 or #2	Diesel #1 or #2
Capacity	37.8 L (10 gal)	37.8 L (10 gal)
Fuel delivery	Inline direct injection	Inline direct injection

	4475	5575
Fuel shut-off	Fuel shutoff solenoid	Fuel shutoff solenoid
POWER TRAIN		
Type	Hydrostatic	Hydrostatic
Charge pump	Gear	Gear
Hydrostatic pump	Variable displacement axial piston	Variable displacement axial piston
Hydrostatic pump relief pressure	23443-26201 kPa (3400-3800 psi)	23443-26201 kPa (3400-3800 psi)
Hydrostatic motor	Fixed displacement axial piston	Fixed displacement axial piston
Chain case capacity (each side)	5.7 L (1.5 gal.)	5.7 L (1.5 gal.)
Parking Brake	Dry disk on hydrostatic motor shaft	Dry disk on hydrostatic motor shaft
STEERING		
Type	Hydrostatic left and right drive motor s	Hydrostatic left and right drive motor s
PERFORMANCE		
SAE operating load	617 kg (1360 lb.)	640 kg (1410 lb.)
Hydraulic lift capacity	658 kg (1450 lb.)	658 kg. (1450 lb.)
Ground speed	0 - 10.5 km/h (0 - 6.5 mph)	0 - 10.5 km/h (0 - 6.5 mph)
Operating weight	1979 kg (4360 lb.)	2020 kg. (4450 lb.)
HYDRAULICS		
Main system relief pressure	17927 kPa (2600 psi)	17927 kPa (2600 psi)
Circuit relief pressure	18961 kPa (2750 psi)	18961 kPa (2750 psi)
Charge relief pressure	758 kPa (110 psi)	758 kPa (110 psi)
Charge pump flow	42 L/min. (11 gmp)	42 L/min. (11 gmp)
Hydraulic valve	3 spool open center	3 spool open center
DIMENSIONS		
Length less bucket	2446 mm (96.3 in.)	2446 mm (96.3 in.)
Length with bucket	3048 mm (120 in.)	3048 mm (120 in.)
Width less bucket	1524 (60 in.)	1524 (60 in.)
Height to ROPS	1839 mm (72.4 in.)	1839 mm (72.4 in.)
Height to hinge pin	2822 mm (111.1 in.)	2822 mm (111.1 in.)
Dump height	2233 mm (87.9 in.)	2233 mm (87.9 in.)
Dump reach	514 mm (20.25 in.)	514 mm (20.25 in.)
Dump angle	45°	45°



	4475	5575
Bucket rollback	36°	36°
Wheelbase	950 mm (37.4 in.)	950 mm (37.4 in.)
Ground clearance	210 mm (8.25 in.)	210 mm (8.25 in.)
Angle of departure	26°	26°

a. Specifications and design subject to change without notice.

	6675	7775
ENGINE^a		
Make	John Deere Series 220	John Deere Series 220
Model	4020D001	4022D001
Type	Diesel	Diesel
Cylinders	4	4
Bore	84 mm (3.31 in.)	88 mm (3.46 in.)
Stroke	90 mm (3.54 in.)	90 mm (3.54 in.)
Displacement	2.0 L (124 cu. in.)	2.2 L (137 cu. in.)
Net horsepower	31 kW (42) @ 3000 rpm	37 kW (49) @ 3000 rpm
RPM, slow (no load)	900 - 1000	900 - 1000
RPM, fast (no load)	3125 - 3175	3125 - 3175
Lubrication	Full pressure	Full pressure
Crankcase capacity (with filter)	8.4 L (8.9 qt.)	8.4 L (8.9 qt.)
Cooling system	Liquid	Liquid
Coolant system capacity radiator and block	10.3 L (10.8 qt.)	10.3 L (10.8 qt.)
Air filter type	Dry paper with primary and secondary elements	Dry paper with primary and secondary elements
ELECTRICAL		
Type of starter	Solenoid shift	Solenoid shift
Battery voltage	12 V	12V
Battery reserve capacity at 27°C (80° F)	160 minutes	160 minutes
Battery cold cranking amps at -18°C (0°F)	625	625
Charging system	40 amp alternator	40 amp alternator

	6675	7775
Headlights	37.5 Watt Halogen	37.5 Watt Halogen
FUEL SYSTEM		
Fuel	Diesel # 1 or # 2	Diesel # 1 or # 2
Capacity	54.1 L (14.3 gal)	54.1 L (14.3 gal)
Fuel delivery	Inline direct injection	Inline direct injection
Fuel shut-off	Fuel shutoff solenoid	Fuel shutoff solenoid
POWER TRAIN		
Type	Hydrostatic	Hydrostatic
Charge pump	Gear	Gear
Hydrostatic pump	Variable displacement axial piston	Variable displacement axial piston
Hydrostatic pump relief pressure	23443-26201 kPa (3400-3800 psi)	23443-26201 kPa (3400-3800 psi)
Hydrostatic motor	Fixed displacement axial piston	Fixed displacement axial piston
Chain case capacity (each side)	7.6 L (2 gal.)	7.6 L (2 gal.)
Gearbox capacity (each gearbox box)	0.95 L (1 qt.)	0.95 L (1 qt.)
Brakes	Dry disk on hydrostatic motor shaft	Dry disk on hydrostatic motor shaft
STEERING		
Type	Power - hydrostatic	Power - hydrostatic
PERFORMANCE		
SAE operating load	758 kg (1670 lb.)	774 kg (1705 lb.)
Hydraulic lift capacity	908 kg (2000 lb.)	908 kg (2000 lb.)
Ground speed	0 - 11.7 km/h (0 - 7.3 mph)	0 - 11.9 km/h (0 - 7.4 mph)
Operating weight	2443 kg (5385 lb.)	2452 kg (5405 lb.)
HYDRAULICS		
Main system relief pressure	17927 kPa (2600 psi)	17927 kPa (2600 psi)
Circuit relief pressure	18961 kPa (2750 psi)	18961 kPa (2750 psi)
Charge relief pressure	758 kPa (110 psi)	758 kPa (110 psi)
Charge pump flow	56 L/min. (15 gmp)	64 L/min. (17 gmp)
Hydraulic valve	3 spool open center	3 spool open center
Built-in boom locks	Yes	Yes













	6675	7775
DIMENSIONS		
Length less bucket	2585 mm (101.8 in.)	2585 mm (101.8 in.)
Length with bucket	3218 mm (126.7 in.)	3218 mm (126.7 in.)
Width less bucket	1666 (65.6 in.)	1666 (65.6 in.)
Height to ROPS	1897 mm (74.7 in.)	1897 mm (74.7 in.)
Height to hinge pin	2934 mm (115.5 in.)	2934 mm (115.5 in.)
Operating height	3556 mm (140 in.)	3556 mm (140 in.)
Dump height	2296 mm (90.4 in.)	2296 mm (90.4 in.)
Dump reach	711 mm (28 in.)	711 mm (28 in.)
Dump angle	45°	45°
Bucket rollback	36°	36°
Wheelbase	1080mm (42.5 in.)	1080mm (42.5 in.)
Ground clearance	196 mm (7.7 in.)	196 mm (7.7 in.)
Angle of departure	26°	26°
Circle clearance	3454 mm (136 in.)	3454 mm (136 in.)

a. Specifications and design subject to change without notice.

UNIFIED INCH TORQUE VALUES



SAE Grade and Head Markings	1 or 2 ^b No Marks 	5  5.1  5.2 	8  8.2 
	2 No Marks 	5  	8  

TS1162

SIZE	Grade 1		Grade 2 ^b		Grade 5, 5.1 or 5.2		Grade 8 or 8.2	
	Lubricated ^a	Dry ^a	Lubricated ^a	Dry ^a	Lubricated ^a	Dry ^a	Lubricated ^a	Dry ^a
	Nm	lb-ft	Nm	lb-ft	Nm	lb-ft	Nm	lb-ft
1/4	3.7	2.8	4.7	3.5	6	4.5	7.5	5.5
5/16	7.7	5.5	10	7	12	9	15	11
3/8	14	10	17	13	22	16	27	20
7/16	22	16	28	20	35	26	44	32
1/2	33	25	42	31	53	39	67	50
9/16	48	36	60	45	75	56	95	70
5/8	67	50	85	62	105	78	135	100
3/4	120	87	150	110	190	140	240	175
7/8	190	140	240	175	190	140	240	175
1	290	210	360	270	290	210	360	270
1-1/8	470	300	510	375	470	300	510	375
1-1/4	570	425	725	530	570	425	725	530
1-3/8	750	550	950	700	750	550	950	700
1-1/2	1000	725	1250	925	990	725	1250	930

DO NOT use these values if a different torque value or tightening procedure is given for a specific application. Torque values listed are for general use only. Check tightness of fasteners periodically.

Shear bolts are designed to fail under predetermined loads. Always replace shear bolts with identical grade.

Fasteners should be replaced with the same or higher grade. If higher grade fasteners are used, these should only be tightened to the strength of the original. Make sure fasteners threads are clean and that you properly start thread engagement. This will prevent them from failing when tightening. Tighten plastic insert or crimped steel-type lock nuts to approximately 50 percent of the dry torque shown in the chart, applied to the nut, not to the bolt head.

Tighten toothed or serrated-type lock nuts to the full torque value.

^a "Lubricated" means coated with a lubricant such as engine oil, or fasteners with phosphate and oil coatings. "Dry" means plain or zinc plated without any lubrication^b

^b Grade 2 applies for hex cap screws (not hex bolts) up to 152 mm (6-in.) long. Grade 1 applies for hex cap screws over 152 mm (6-in.) long, and for all other types of bolts and screws of any length.

METRIC TORQUE VALUES



Property Class and Head Markings	4.8	8.8	9.8	10.9	12.9
Property Class and Nut Markings	5	10	10	12	

Ts1163

SIZE	Class 4.8		Class 8.8 or 9.8				Class 10.9				Class 12.9					
	Lubricated ^a		Dry ^a		Lubricated ^a		Dry ^a		Lubricated ^a		Dry ^a		Lubricated ^a		Dry ^a	
	Nm	lb-ft	Nm	lb-ft	Nm	lb-ft	Nm	lb-ft	Nm	lb-ft	Nm	lb-ft	Nm	lb-ft	Nm	lb-ft
M6	48	3.5	6	4.5	9	6.5	11	8.5	13	9.5	17	12	15	11.5	19	14.5
M8	12	8.5	15	11	22	16	28	20	32	24	40	30	37	28	47	35
M10	23	17	29	21	43	32	55	40	63	47	80	60	75	55	95	70
M12	40	29	50	37	75	55	95	70	110	80	140	105	130	95	165	120
M14	63	47	80	60	120	88	150	110	175	130	225	165	205	150	260	109
M16	100	73	125	92	190	140	240	175	275	200	350	225	320	240	400	300
M18	135	100	175	125	260	195	330	250	375	275	475	350	440	325	560	410
M20	190	140	240	180	375	275	475	350	530	400	675	500	625	460	800	580
M22	260	190	330	250	510	375	650	475	725	540	925	675	850	625	1075	800
M24	330	250	425	310	650	475	825	600	925	675	1150	850	1075	800	1350	1000
M27	490	360	625	450	950	700	1200	875	1350	1000	1700	1250	1600	1150	2000	1500
M30	675	490	850	625	1300	950	1650	1200	1850	1350	2300	1700	2150	1600	2700	2000
M33	900	675	1150	850	1750	1300	2200	1650	2500	1850	3150	2350	2900	2150	3700	2750
M36	1150	850	1450	1075	2250	1650	2850	2100	3200	2350	4050	3000	3750	2750	4750	3500

DO NOT use these values if a different torque value or tightening procedure is given for a specific application. Torque values listed are for general use only. Check tightness of fasteners periodically.

Shear bolts are designed to fail under predetermined loads. Always replace shear bolts with identical grade.

Fasteners should be replaced with the same or higher grade. If higher grade fasteners are used, these should only be tightened to the strength of the original. Make sure fasteners threads are clean and that you properly start thread engagement. This will prevent them from failing when tightening.

Tighten plastic insert or crimped steel-type lock nuts to approximately 50 percent of the dry torque shown in the chart, applied to the nut, not to the bolt head. Tighten toothed or serrated-type lock nuts to the full torque value.

^a "Lubricated" means coated with a lubricant such as engine oil, or fasteners with phosphate and oil coatings. "Dry" means plain or zinc plated without any lubrication.

^b Grade 2 applies for hex cap screws (not hex bolts) up to 152 mm (6-in.) long. Grade 1 applies for hex cap screws over 152 mm (6-in.) long, and for all other types of bolts and screws of any length.

DIESEL FUEL SPECIFICATIONS

Use only clean, high quality fuel.

Use Grade No. 2-D fuel at temperatures above 4°C (40°F).

Use Grade No. 1-D fuel at temperatures below 4°C (40°F).

Use Grade No. 1-D fuel for all air temperatures at altitudes above 1500 m (5000 ft).

IMPORTANT: Use fuel with less than 1.0 per cent sulfur. If possible, use fuel with less than 0.5 per cent sulfur. If fuel sulfur is more than 0.5 per cent, change engine oil and filter every 100 hours.

For maximum filter life, sediment and water should not be more than 0.10 percent.

The cetane number should be 40 minimum. If you operate your tractor where air temperatures are normally low or where altitudes are high, you may need fuel with a higher cetane number.

Cloud Point - For cold weather operation, cloud point should be 10°F (6°C) below lowest normal air temperature.

Fuel Tank Capacity

4475 and 5575.....37.8 L (10 gal)

6675 and 7775..... 54.1 L (14.3 gal)

DIESEL FUEL STORAGE

NOTE: Diesel fuels stored for a long time may form gum and plug filters.

Keep fuel in a clean container in a protected area. Water and sediment must be removed before fuel gets to the engine. Do not use de-icers to remove water from fuel. Do not depend on fuel filters to remove water. If possible, install a water separator at the storage tank outlet. (See your John Deere dealer for this part.)

IMPORTANT: Keep all dirt, scale, water or other foreign material out of fuel.

Store fuel drum on its side with plug up.

DO NOT STORE DIESEL FUEL IN GALVANIZED CONTAINERS

IMPORTANT: Diesel fuel stored in galvanized containers reacts with the zinc coating of the container to form zinc flakes. If fuel contains any water, a zinc gel will also form. The gel and flakes will quickly plug fuel filters and may damage fuel injectors and fuel pumps.



Store diesel fuel in:

- plastic containers
- aluminum containers
- specially coated steel containers made for diesel fuel.

DO NOT USE BRASS-COATED CONTAINERS: brass is an alloy of copper and zinc.

LUBRICANT SPECIFICATIONS

ENGINE OIL



Use oil viscosity based on the expected air temperature range during the period between oil changes.

The following oil is preferred:

- John Deere TORQ-GARD SUPREME PLUS-50™

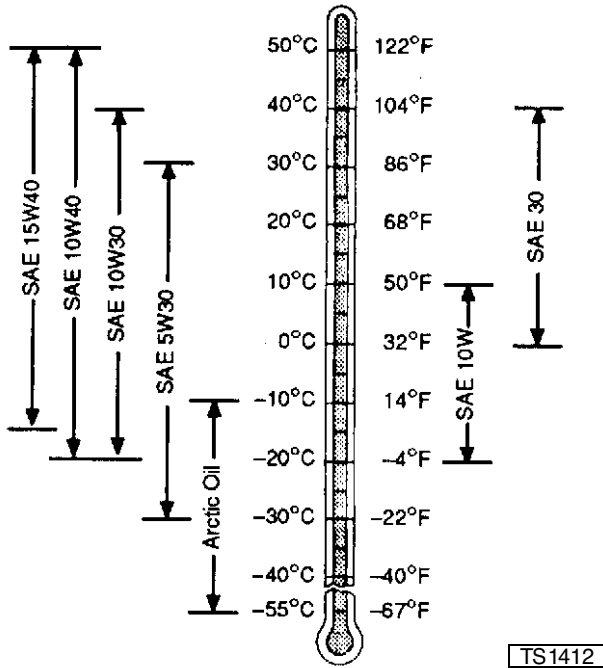

The following oils are also recommended:

- John Deere TORQ-GARD SUPREME®
- John Deere UNI-GARD™

Other oils may be used if they meet one of the following:

- API Service Classification CE
- API Service Classification CD
- CCMC Specification D5
- CCMC Specification D4
- Oils meeting Military Specification MIL-L-46167B may be used as arctic oils.

If John Deere TORQ-GARD SUPREME PLUS-50 engine oil and a John Deere oil filter are used, the oil and filter service interval may be extended by 50 hours.

If diesel fuel exceeding 0.5% sulphur content is used, reduce the service interval for engine oil and filter by 50%.

GREASE

Use grease based on the expected air temperature range during the service interval.

The following greases are preferred:

- John Deere MOLY HIGH TEMPERATURE EP GREASE
- John Deere HIGH TEMPERATURE EP GREASE
- John Deere GREASE-GARD™

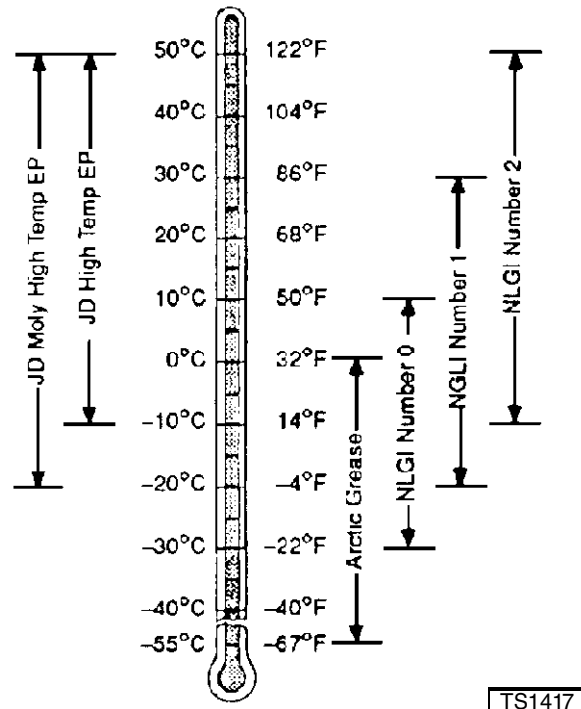

Other greases may be used if they meet one of the following:

- SAE Multipurpose EP Grease with a maximum of 5% molybdenum disulfide.
- SAE Multipurpose EP Grease
- Greases meeting Military Specification MIL-G-10924F may be used as arctic grease.

HYDROSTATIC TRANSMISSION & HYDRAULIC OIL

The following oil is preferred:

- John Deere PLUS-4® 10W-30

The following oil is acceptable for topping of hydraulic reservoir:

- John Deere TURF-GARD®
- 10W-30 oil equivalent to John Deere PLUS-4®
- John Deere HYGARD®

CHAIN CASE OIL

The following oil is preferred:

- John Deere PLUS-4® 10W-30

The following oil is acceptable for topping of chaincase reservoir:

- John Deere TURF-GARD®
- 10W-30 oil equivalent to John Deere PLUS-4®
- John Deere HYGARD®

GEARBOX OIL (6675, 7775)

Use oil viscosity based on the expected air temperature range during the period between oil changes.

John Deere GL-5 Gear Lubricant is recommended.

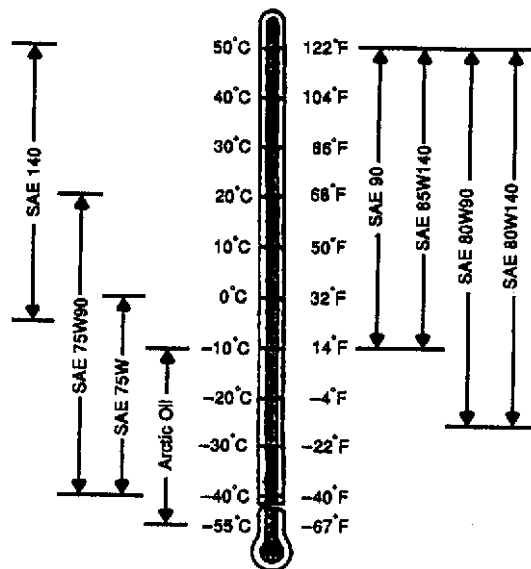

M74991

Other oils may be used if they meet one or more of the following:

- API Service Classification GL-5.
- Military Specification MIL-L-2105D.
- Military Specification MIL-L-2105C.
- Military Specification MIL-L-2105B.

Oils meeting Military Specification MIL-L-10324A may

be used as arctic oils.

ALTERNATIVE LUBRICANTS

Conditions in certain geographical areas outside the United States and Canada may require different lubricant recommendations than those printed in this manual or the operator's manual. Consult with your John Deere Dealer, or Sales Branch to obtain the alternative lubricant recommendations.



SYNTHETIC LUBRICANTS

Synthetic lubricants may be used in John Deere equipment if they meet the applicable performance requirements (industry classification and/or military specification) as shown in this group.

The recommended temperature limits and service or oil change intervals should be maintained as shown in the operator's manual.

Avoid mixing different brands, grades, or types of oil. Oil manufacturers blend additives in their oils to meet certain specifications and performance requirements. Mixing different oils can interfere with the proper functioning of these additives and degrade lubricant performance.

OIL FILTERS

Filtration of oils is critical to proper lubrication. Always change filters regularly.

Use filters meeting John Deere performance specification.

LUBRICANT STORAGE

This machine can operate at top efficiency only if clean lubricants are used.

Use clean containers to handle all lubricants. Store them in an area protected from dust, moisture, and other contamination. Store drums on their sides.

ENGINE COOLANT

Use ethylene glycol base coolant. These coolants usually have labels stating "For Automobile and Light Duty Service." These products are also often labeled for use in aluminum engines. Check container label before using.



IMPORTANT: To prevent engine damage, DO NOT use pure antifreeze or more than 50% antifreeze in the cooling system. DO NOT mix or add any other type additives to the cooling system.

Mix approximately 50 percent antifreeze with 50 percent distilled or deionized water. This mixture will provide freeze protection to -34⁰ F (-37⁰ C).

Certain geographical areas may require lower temperature protection. See the label on your antifreeze container or consult your John Deere dealer to obtain the latest information and recommendations.

The recommended antifreeze provides:

- Adequate heat transfer.
- Corrosion-resistant environment within the cooling system.
- Compatibility with cooling system hose and seal material.
- Protection during cold and hot weather operations.

SERIAL NUMBER LOCATION

When ordering parts or submitting a warranty claim, it is **IMPORTANT** that you include the skid steer loader product identification number and the component serial numbers.

The location of skid steer loader product identification number and component serial numbers are shown.

SKID STEER LOADER PRODUCT IDENTIFICATION NUMBER



ENGINE SERIAL NUMBER

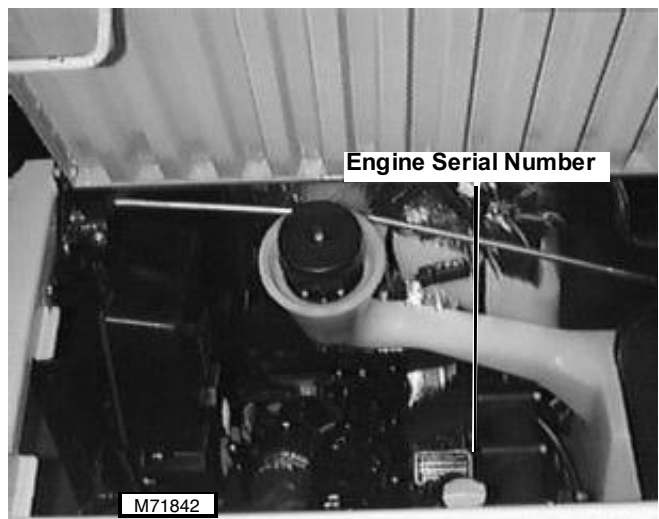

CONTENTS

Page

DIESEL ENGINE

SPECIFICATIONS — 3015D001 (3TNE84)	5
GENERAL SPECIFICATIONS	5
REPAIR SPECIFICATIONS	5
CHECKS, TESTS AND ADJUSTMENTS	11
OPERATIONAL TESTS	12
SPECIFICATIONS - 4020D001 (4TNE84)	13
GENERAL SPECIFICATIONS	13
REPAIR SPECIFICATIONS	13
CHECKS, TESTS AND ADJUSTMENTS	19
OPERATIONAL TESTS	20
SPECIFICATIONS - 3017D001 (3TNE88)	21
GENERAL SPECIFICATIONS	21
REPAIR SPECIFICATIONS	22
CHECKS, TESTS AND ADJUSTMENTS	28
OPERATIONAL TESTS	29
SPECIFICATIONS - 4022D001 (4TNE88)	30
GENERAL SPECIFICATIONS	30
REPAIR SPECIFICATIONS	30
CHECKS, TESTS AND ADJUSTMENTS	36
OPERATIONAL TESTS	37
ENGINE COMPONENT LOCATION	38
THEORY OF OPERATION	39
COOLING SYSTEM OPERATION	39
LUBRICATION SYSTEM OPERATION	40
FUEL AND AIR SYSTEM OPERATION	42
TROUBLESHOOTING	44
ENGINE SYSTEM DIAGNOSIS	46
CHECKS, TESTS AND ADJUSTMENTS	48
CYLINDER COMPRESSION PRESSURE TEST	48
THROTTLE CONTROL ADJUSTMENT	48
FUEL SHUTOFF SOLENOID ADJUSTMENT	49
SLOW IDLE ADJUSTMENT	49
FAST IDLE ADJUSTMENT	50
INJECTION PUMP TIMING ADJUSTMENT	50
VALVE CLEARANCE CHECK AND ADJUSTMENT	51
CONNECTING ROD SIDE PLAY CHECK	52
CONNECTING ROD BEARING CLEARANCE CHECK	52
CRANKSHAFT END PLAY CHECK	53
CRANKSHAFT MAIN BEARING CLEARANCE CHECK	54
VALVE LIFT CHECK	54
CAMSHAFT END PLAY CHECK	55
TIMING GEAR BACKLASH CHECK	55
FUEL INJECTION NOZZLE TEST (HOLE-TYPE)	56





	Page
THERMOSTAT OPENING TEST	58
INJECTION PUMP STATIC TIMING ADJUSTMENT	59
FAN/ALTERNATOR DRIVE BELT ADJUSTMENT	60
RADIATOR BUBBLE TEST	61
COOLING SYSTEM PRESSURE TEST	61
RADIATOR CAP PRESSURE TEST	62
ENGINE OIL PRESSURE TEST	62
AIR INTAKE SYSTEM LEAKAGE TEST	63
FUEL SUPPLY PUMP PRESSURE TEST	63
FUEL SYSTEM LEAKAGE TEST	64
BLEED FUEL SYSTEM	64
ENGINE REMOVAL	65
ENGINE REMOVAL WITH CAB TILTED	65
ENGINE REMOVAL WITHOUT CAB TILTED	66
CYLINDER HEAD, VALVES AND MANIFOLDS	67
SPECIAL OR ESSENTIAL TOOLS	67
SERVICE PARTS KITS	67
ROCKER ARM COVER	68
ROCKER ARM ASSEMBLY	69
INSPECTION	71
CYLINDER HEAD AND VALVES	72
REMOVAL/INSTALLATION	72
EXHAUST MANIFOLD	78
INTAKE MANIFOLD	79
GRIND VALVE SEATS	79
LAP VALVES	80
MEASURE PISTON-TO-CYLINDER HEAD CLEARANCE	80
PISTONS, RODS AND CYLINDER BLOCK	81
SERVICE PARTS KITS	81
PISTON AND CONNECTING ROD	81
ASSEMBLY	82
CYLINDER BORE	87
REBORING	88
CRANKSHAFT, MAIN BEARINGS AND FLYWHEEL	89
OTHER MATERIALS	89
SERVICE PARTS KITS	89
CRANKCASE EXTENSION HOUSING	89
CRANKSHAFT REAR OIL SEAL	90
CRANKSHAFT FRONT OIL SEAL	90
CRANKSHAFT AND MAIN BEARINGS	90
FLYWHEEL	96
FLYWHEEL HOUSING	96
CAMSHAFT AND TIMING GEAR TRAIN	97
SPECIAL OR ESSENTIAL TOOLS	97
OTHER MATERIALS	97

	Page
SERVICE PARTS KITS	97
CAMSHAFT	97
CAM FOLLOWERS	100
TIMING GEAR COVER	101
IDLER GEAR	103
TIMING GEAR COVER MOUNTING PLATE	104
LUBRICATION SYSTEM	105
OTHER MATERIALS	105
OIL PAN AND STRAINER	105
OIL PUMP	106
OIL PRESSURE REGULATING VALVE	108
COOLING SYSTEM	109
THERMOSTAT AND WATER PUMP	109
FUEL SYSTEM	110
SPECIAL OR ESSENTIAL TOOLS	110
SERVICE PARTS KITS	110
FUEL FILTER ASSEMBLY	111
FUEL INJECTION PUMP	112
FUEL INJECTION NOZZLES	114
STARTER - NIPPONDENSO	117
MOTOR ASSEMBLY	118
MOTOR INSPECTION/TEST	119
STARTER GEAR TRAIN	120
STARTER SOLENOID	122
VOLTAGE REGULATOR – HITACHI 40A	123
ALTERNATOR - HITACHI 40A	123
DISASSEMBLY	123
ASSEMBLY	125
INSPECTION/TEST	125





SPECIFICATIONS — 3015D001 (3TNE84)

GENERAL SPECIFICATIONS

Make	John Deere Series 220
Model	3015D001
Type	Vertical, 4-cycle Diesel
Output Power	31 HP (23 kW)
Cylinders	3
Bore	84 mm (3.31 in.)
Stroke	90 mm (3.54 in.)
Displacement	1.496 L (91.3 cu. in.)
Firing Order	1—3—2—1
Direction of Rotation	Counterclockwise (viewed from flywheel)
Combustion System	Direct Injection Type
Compression Ratio	18 to 1
Cooling	Liquid
Governor	Centrifugal
RPM at Idle	900—1000
RPM at High Idle (no-load)	3125—3175
Rated RPM	3000
Torque Rise	20% min



Startability

W/O Block Heater	-17.8° C
W/ Block Heater	-28.9° C

REPAIR SPECIFICATIONS

Rocker Arm Cover

Special Nut Torque	18 N•m (160 lb-in.)
--------------------	---------------------

Rocker Arm Assembly

Mounting Cap Screw Torque	26 N•m (226 lb-in.)
Rocker Arm Shaft O.D.	
Standard	15.97 - 15.98 mm (0.6286 - 0.6293 in.)
Wear Limit	15.95 mm (0.6280 in.)
Rocker Arm and Shaft Support I.D.'s	
Clearance	0.016 mm (0.0006 in.)
Standard	16.00 - 16.02 mm (0.630 - 0.631 in.)
Wear Limit	16.09 mm (0.633 in.)
Push Rod Length	
Standard	178.25 - 178.75 mm (7.018 - 7.037 in.)
Push Rod Bend	
Standard	0.03 mm (0.001 in.) or less
Wear Limit	0.30 mm (0.012 in.)

Cylinder Head and Valves

Mounting Cap Screw Torque

First	24 N•m (17 lb-ft.)
Second	48 N•m (36 lb-ft.)
Final	88 N•m (65 lb-ft.)

Cylinder Head Distortion

Standard	0.05 mm (0.002 in.) or less
Wear Limit	0.15 mm (0.006 in.)
Maximum Amount of Metal to be Removed	0.20 mm (0.008 in.)

Valve Seat Width

Intake Valve	
Standard	1.07 - 1.24 mm (0.042 - 0.049 in.)
Wear Limit	1.74 mm (0.069 in.)
Exhaust Valve	
Standard	1.24 - 1.45 mm (0.049 - 0.057 in.)
Wear Limit	1.94 mm (0.076 in.)



Intake and Exhaust Valves

Valve Faces

Minimum Margin	0.51 mm (0.020 in.)
Exhaust Angle	45°
Intake Angle	30°

Valve Stem O.D.

Distance A	30 mm (1.181 in.)
Distance B	60 mm (2.360 in.)
Standard	7.96 - 7.98 mm (0.3134 - 0.3142 in.)
Wear Limit	7.90 mm (0.3110 in.)

Valve Recession

Standard	0.30 - 0.50 mm (0.012 - 0.020 in.)
Wear Limit	1.00 mm (0.039 in.)

Valve Guides

Valve Guide I.D.

Oil Clearance	0.035 - 0.070 mm (0.001 - 0.003 in.)
Standard	8.01 - 8.03 (0.315 - 0.316 in.)
Wear Limit	8.10 mm (0.319 in.)
Valve Guide Height	15 mm (0.591 in.)

Valve Springs

Spring Free Length	
Standard	42 mm (1.655 in.)
Wear Limit	39.50 mm (1.550 in.)
Maximum Spring Inclination	1.10 mm (0.044 in.)

Exhaust Manifold

Mounting Cap Screw and Nut Torque	26 N•m (226 lb-in.)
---	---------------------

Intake Manifold

Mounting Cap Screw Torque 26 N•m (226 lb-in.)

Valve Seat Angles

Valve Seat Surface

Exhaust Valve 45°
 Intake Valve 30°
 Lower Seat Surface 70°
 Upper Seat Surface 15°

Piston-to-Cylinder Head Clearance

Standard 0.64 - 0.82 mm (0.025 - 0.032 in.)

Piston and Connecting Rod Cap Screw Torque 47 N•m (35 lb-ft.)

Connecting Rod Bearing I.D.

Standard 48 - 48.028 mm (1.888 - 1.891 in.)
 Wear Limit 48.07 mm (1.893 in.)
 Clearance 0.038 - 0.074 mm (0.0015 - 0.0029 in.)

Piston Ring Groove Clearance

First Compression Ring

Standard 0.075 - 0.110 mm (0.0030 - 0.0043 in.)
 Wear Limit 0.25 mm (0.0098 in.)

Second Compression Ring

Standard 0.045 - 0.080 mm (0.0018 - 0.0031 in.)
 Wear Limit 0.25 mm (0.0098 in.)

Oil Ring

Standard 0.025 - 0.060 mm (0.0010 - 0.0024 in.)
 Wear Limit 0.20 mm (0.0079 in.)

Piston Ring End Gap

Standard 0.20 - 0.40 mm (0.008 - 0.016 in.)
 Wear Limit 1.50 mm (0.0591 in.)

Piston Pin

Pin O.D.

Standard 25.987 - 26.00 mm (1.023 - 1.024 in.)
 Wear Limit 25.90 mm (1.020 in.)

Bore I.D.

Clearance 0.022 mm (0.0009 in.)
 Standard 26.00 - 26.009 mm (1.0236 - 1.0240 in.)
 Wear Limit 26.02 mm (1.024 in.)

Bushing I.D.

Clearance 0.025 - 0.051 mm (0.0009 - 0.002 in.)
 Standard 26.025 - 26.038 mm (1.0246 - 1.0251 in.)



Piston O.D.

Distance A	23 mm (0.905 in.)
Standard Size Piston	
Standard.	83.94 - 83.97 mm (3.305 - 3.306 in.)
Wear Limit	83.90 mm (3.303 in.)
0.25 mm (0.010 in.) Oversize Piston	
Standard.	84.19 - 84.22 mm (3.315 - 3.316 in.)
Wear Limit	84.15 mm (3.313 in.)

Cylinder Bore I.D.



Standard Size Bore	
Clearance.	0.040 - 0.070 mm (0.0016 - 0.0028 in.)
Standard.	84.00 - 84.03 mm (3.307 - 3.308 in.)
Wear Limit	84.20 mm (3.315 in.)
0.25 mm (0.010 in.) Oversize Bore	
Standard.	84.25 - 84.28 mm (3.317 - 3.318 in.)
Wear Limit	84.45 mm (3.325 in.)

Deglazing 30 - 40° cross-hatch pattern

Reboring 30 - 40° cross-hatch pattern

Crankcase Extension Housing

Mounting Cap Screw Torque	
Flywheel Housing/Plate-to-Extension	49 N•m (36 lb-ft.)
Seal Case-to-Extension	26 N•m (226 lb-in.)
Extension-to-Block	27 N•m (20 lb-ft.)
Extension-to-Timing Gear Cover	22 N•m (195 lb-in.)

Crankshaft Rear Oil Seal

Seal Case-to-Block Cap Screw Torque	26 N•m (226 lb-in.)
Seal Case-to-Extension Cap Screw Torque	21 N•m (180 lb-in.)

Crankshaft and Main Bearings

Main Bearing Cap Screw Torque	98 N•m (72 lb-ft.)
Crankshaft Maximum Bend	0.02 mm (0.0007 in.)
Connecting Rod Journal O.D.	
Standard.	47.952 - 47.962 mm (1.8879 - 1.8883 in.)
Wear Limit	47.91 mm (1.886 in.)
Main Bearing Journal O.D.	
Standard.	53.952 - 53.962 mm (2.124 - 2.125 in.)
Wear Limit	53.91 mm (2.122 in.)
Main Bearing I.D.	
Clearance.	0.038 - 0.068 mm (0.0015 - 0.0027 in.)
Standard.	53.995 - 54.025 (2.123 - 2.127)
Wear Limit	54.020 (2.127)

Flywheel

Maximum Distortion	0.02 mm (0.0008 in.)
Mounting Cap Screw Torque	83 N•m (61 lb-ft.)
Flywheel Housing/Plate Mounting Cap Screw Torque	49 N•m (36 lb-ft.)

Camshaft

Mounting Cap Screw Torque	26 N•m (226 lb-in.)
Camshaft Side Gap	
Standard	0.05 - 0.25 mm (0.0020 - 0.0098 in.)
Maximum Camshaft Bend	0.02 mm (0.001 in.)
Lobe Height	
Standard	38.635 - 38.765 mm (1.521 - 1.526 in.)
Wear Limit	38.40 mm (1.512 in.)
Bearing Journal O.D.	
Flywheel Side	44.925 - 44.950 mm (1.769 - 1.770 in.)
Intermediate Journal	44.910 - 44.935 mm (1.768 - 1.769 in.)
Gear Side	44.925 - 44.950 mm (1.769 - 1.770 in.)
Wear Limit	44.850 mm (1.766 in.)
Oil Clearance (Gear and Flywheel Ends)	0.040 - 0.130 mm (0.002 - 0.005 in.)
Oil Clearance (Intermediate)	0.065 - 0.115 mm (0.003 - 0.005 in.)
Bushing I.D.	
Clearance	0.20 mm (0.0078 in.)
Standard	44.990 - 45.055 mm (1.771 - 1.744 in.)
Wear Limit	45.10 mm (1.776 in.)
Bore I.D.	
Clearance	0.20 mm (0.008 in.)
Standard	45.00 - 45.025 mm (1.772 - 1.773 in.)
Wear Limit	45.10 mm (1.776 in.)



Cam Followers

Stem O.D.	
Standard	11.975 - 11.990 mm (0.471 - 0.472 in.)
Wear Limit	11.93 mm (0.470 in.)
Bore I.D.	
Clearance	0.10 mm (0.004 in.)
Standard	12.000 - 12.018 mm (0.472 - 0.473 in.)
Wear Limit	12.05 mm (0.474 in.)

Engine Torques, General

Cover Mounting Cap Screw Torque	26 N•m (226 lb-in.)
Crankcase Extension Housing-to-Cover Cap Screw Torque	22 N•m (195 lb-in.)
Crankshaft Pulley Cap Screw Torque	115 N•m (85 lb-ft.)
Fan Mounting Cap Screw Torque	11 N•m (226 lb-in.)
Oil Pan-to-Cover Cap Screw Torque	22 N•m (195 lb-in.)
Timing Gear Cover Mounting Plate Cap Screw Torque	25 N•m (220 lb-in.)
Oil Pan and Strainer Mounting Cap Screw Torque	26 N•m (226 lb-in.)

Idler Gear

Shaft O.D

Standard 45.950 - 45.975 mm (1.809 - 1.810 in.)
 Wear Limit 45.93 mm (1.808 in.)

Bushing I.D.

Clearance 0.15 mm (0.0059 in.)
 Standard 46.00 - 46.025 mm (1.811 - 1.812 in.)
 Wear Limit 46.03 mm (1.812 in.)

Oil Pump



Gear Backlash

Standard 0.04 - 0.12 mm (0.002 - 0.005 in.)

Mounting Cap Screw Torque 11 N•m (8 lb-ft.)

Rotor Shaft O.D.-to-Backing Plate I.D. Clearance

Standard 0.013 - 0.043 mm (0.0005 - 0.0017 in.)
 Wear Limit 0.20 mm (0.0078 in.)

Rotor Recess

Standard 0.03 - 0.09 mm (0.0011 - 0.0035 in.)
 Wear Limit 0.15 mm (0.0059 in.)

Outer Rotor-to-Pump Body Clearance

Standard 0.10 - 0.16 mm (0.0039 - 0.0063 in.)
 Wear Limit 0.25 mm (0.0098 in.)

Inner-to-Outer Rotor Clearance

Standard 0.05 - 0.105 mm (0.0019 - 0.0041 in.)
 Wear Limit 0.15 mm (0.0059 in.)

Oil Pressure Regulating Valve

Spring

Compressed Length 27.50 mm (1.080 in.) @ 20.5 N (4.6 lb-force)
 Free Length 46 mm (1.810 in.)
 Housing-to-Valve Body Retaining Nut Torque 30 N•m (22 lb-ft.)
 Housing-to-Engine Block Cap Screw Torque 27 N•m (20 lb-ft.)

Thermostat and Housing

Thermostat Cover Cap Screw Torque 20 N•m (180 lb-in.)
 Plate-to-Housing Cap Screw Torque 9 N•m (78 lb-in.)
 Housing Mounting Cap Screw Torque 26 N•m (226 lb-in.)

Water Pump

Fan Mounting Cap Screw 11 N•m (96 lb-in.)
 Mounting Cap Screw Torque 26 N•m (226 lb-in.)
 Plate-to-Housing Screw Torque 15 N•m (134 lb-in.)
 Plug-to-Housing Torque 15 N•m (130 lb-in.)

Fuel Injection Pump

Injection Pump Gear Nut Torque 90 N•m (66 lb-ft.)
 Mounting Nut Torque 26 N•m (19 lb-ft.)
 Lube Line-to-Block Bolt Torque 25 N•m (217 lb-in.)

Fuel Injection Nozzles

Mounting Nut Torque 5 N•m (39 lb-in.)
 Retaining Nut Torque 8 N•m (72 lb-ft.)
 Separator Plate Nozzle Contact Surface Maximum Wear . . . 0.10 mm (0.0039 in.)

Starter Motor - (Nippondenso 1.4 kW)

Rotation Clockwise
 No-load Amperage Draw (Max) 90
 No-load Rpm (Min) 3500
 Loaded Amperage Draw (Max) 350
 Minimum Brush Length 8.5 mm (0.335 in.)
 Through Bolt Torque 7 - 12 N•m (62 - 106 lb-in.)
 Lead Terminal Nut 6 - 10 N•m (53 - 88 lb-in.)



Alternator - Hitachi 40A

Attaching Screw Torque 4 N•m (31 lb-in.)
 Rotor Assembly
 Retainer-to-Front Frame Screw Torque 2 N•m (16 lb-in.)
 Sheave Nut Torque 49 N•m (36 lb-ft.)
 End Frame-to-Rectifier Nut Torque 4 N•m (31 lb-in.)
 Stator-to-Rectifier Lead Wire Distance 33.50 mm (1.300 in.)
 Minimum Brush Length 5.50 mm (0.220 in.)

Checks, Tests and Adjustments

Valve Clearance 0.15 - 0.25 mm (0.006 - 0.010 in.)

Connecting Rod Side Play

Standard Clearance 0.20 - 0.40 mm (0.0079 - 0.0157 in.)
 Wear Limit 0.55 mm (0.0217 in.)

Connecting Rod Bearing Clearance

Standard Clearance 0.038 - 0.074 mm (0.0015 - 0.0029 in.)

Crankshaft End Play

Standard Clearance 0.090 - 0.271 mm (0.004 - 0.011 in.)
 Wear Limit 0.33 mm (0.0129 in.)

Crankshaft Main Bearing Clearance

Main Bearing Cap Screw Torque 98 N•m (72 lb-ft.)
 Standard Clearance 0.038 - 0.068 mm (0.0015 - 0.0027 in.)

Valve Lift

Valve Lift (Intake and Exhaust) 8.8 mm (0.350 in.)

Camshaft End Play

Standard Clearance 0.05 - 0.25 mm (0.0020 - 0.0098 in.)

Timing Gear Backlash

Standard Backlash 0.04 - 0.12 mm (0.0016 - 0.0047 in.)

Fuel Injection Nozzle

Opening Pressure 21568 + 979 kPa (3128 + 142 psi)

Leakage at 19609 kPa (2844 psi) Minimum of 5 Seconds

Chatter and Spray Pattern at 21568 kPa (3128 psi)

Slow Hand Lever Movement Chatter Sound

Slow Hand Lever Movement Fine Stream Spray Pattern

Fast Hand Lever Movement Fine Atomized Spray Pattern



Thermostat

Begin Opening 71° C (160°F)

Fully Open 85° C (184° F)

Minimum Lift Height (@ 85°C and above) 8 mm (0.310 in.)

Coolant Temperature Switch Continuity 107 - 113° C (225 - 235° F)

Fuel Injection Pump Static Timing Adjustment

Injection Pump Timing

. 16 ± 1° BTDC

Engine Crankshaft Position No. 1 Cylinder on TDC Compression Stroke

Distance on Outer Surface of Flywheel Per 1° of Rotation 2.88 mm (0.110 in.)

Timing Lines on Pump Mounting Plate 2.5° Apart

Fan/Alternator Drive Belt Tension

Applied Force 98 N (22 lb-force)

Deflection 10 - 15 mm (0.400 - 0.600 in.)

Operational Tests

Radiator, Bubble Test

Maximum Air Pressure Into Cylinder 2158 kPa (313 psi)

Cooling System

Maximum Pressure 97 kPa (14 psi)

Minimum Pressure after 15 Seconds 88 kPa (12.8 psi)

Radiator Cap

Valve Opening Pressure 88 kPa (12.8 psi)

Cylinder, Compression Pressure

Minimum Compression Pressure 2448 kPa (355 psi)

Maximum Difference Between Cylinders 490 kPa (71 psi)

Idle Speed

Fast 3150 ± 25 rpm

Slow 950 ± 50 rpm

Oil Pressure

Fast Idle 365 ± 69 kPa (53 ± 10 psi)
 Slow Idle 147 kPa (21 psi)

Air Intake System Holding Pressure 34 - 69 kPa (5 - 10 psi)

Minimum Fuel Supply Pump Pressure 29 kPa (4.3 psi)

Fuel System Holding Pressure (Maximum) 103 kPa (15 psi)

SPECIFICATIONS - 4020D001 (4TNE84)



GENERAL SPECIFICATIONS

Make John Deere Series 220
 Model 4020D001
 Type Vertical, 4-cycle Diesel
 Output Power @2800 RPM 31 kW (42 HP)
 Cylinders 4
 Bore 84 mm (3.31 in.)
 Stroke 90 mm (3.54 in.)
 Displacement 1.496 L (91.3 cu. in.)
 Firing Order 1—3—4—2
 Direction of Rotation Counterclockwise (viewed from flywheel)
 Combustion System Direct Injection Type
 Compression Ratio 18 to 1
 Cooling Liquid
 Governor Centrifugal
 RPM at Idle 900—1000
 RPM at High Idle (no-load) 3125—3175
 Rated RPM 3000
 Torque Rise 20% min

Startability

W/O Block Heater -17.8° C
 W/ Block Heater -28.9° C

REPAIR SPECIFICATIONS

Rocker Arm Cover

Special Nut Torque 18 N•m (160 lb-in.)

Rocker Arm Assembly

Mounting Cap Screw Torque 26 N•m (226 lb-in.)
 Rocker Arm Shaft O.D.
 Standard 15.97 - 15.98 mm (0.6286 - 0.6293 in.)
 Wear Limit 15.95 mm (0.6280 in.)
 Rocker Arm and Shaft Support I.D.'s

Clearance	0.016 mm (0.0006 in.)
Standard	16.00 - 16.02 mm (0.630 - 0.631 in.)
Wear Limit	16.09 mm (0.633 in.)
Push Rod Length	
Standard	178.25 - 178.75 mm (7.018 - 7.037 in.)
Push Rod Bend	
Standard	0.03 mm (0.001 in.) or less
Wear Limit	0.30 mm (0.012 in.)

Cylinder Head and Valves



Mounting Cap Screw Torque

First	24 N•m (17 lb-ft.)
Second	48 N•m (36 lb-ft.)
Final	88 N•m (65 lb-ft.)

Cylinder Head Distortion

Standard	0.05 mm (0.002 in.) or less
Wear Limit	0.15 mm (0.006 in.)
Maximum Amount of Metal to be Removed	0.20 mm (0.008 in.)

Valve Seat Width

Intake Valve

Standard	1.07 - 1.24 mm (0.042 - 0.049 in.)
Wear Limit	1.74 mm (0.069 in.)

Exhaust Valve

Standard	1.24 - 1.45 mm (0.049 - 0.057 in.)
Wear Limit	1.94 mm (0.076 in.)

Intake and Exhaust Valves

Valve Faces

Minimum Margin	0.51 mm (0.020 in.)
Exhaust Angle	45°
Intake Angle	30°

Valve Stem O.D.

Distance A	30 mm (1.181 in.)
Distance B	60 mm (2.360 in.)

Head Size, Intake and Exhaust Valves

Standard	7.96 - 7.98 mm (0.3134 - 0.3142 in.)
Wear Limit	7.90 mm (0.3110 in.)

Valve Recession

Standard	0.30 - 0.50 mm (0.012 - 0.020 in.)
Wear Limit	1.00 mm (0.039 in.)

Valve Guides

Valve Guide I.D.

Oil Clearance	0.035 - 0.070 mm (0.001 - 0.003 in.)
Standard	8.01 - 8.03 (0.315 - 0.316 in.)
Wear Limit	8.10 mm (0.319 in.)

Valve Guide Height 15 mm (0.591 in.)

Valve Springs

Spring Free Length
 Standard 42 mm (1.655 in.)
 Wear Limit 39.50 mm (1.550 in.)
 Maximum Spring Inclination 1.10 mm (0.044 in.)

Exhaust Manifold

Mounting Cap Screw and Nut Torque 26 N•m (226 lb-in.)

Intake Manifold

Mounting Cap Screw Torque 26 N•m (226 lb-in.)

Valve Seat Angles

Valve Seat Surface
 Exhaust Valve 45°
 Intake Valve 30°
 Lower Seat Surface 70°
 Upper Seat Surface 15°

Piston-to-Cylinder Head Clearance

Standard 0.64 - 0.82 mm (0.025 - 0.032 in.)

Piston and Connecting Rod Cap Screw Torque 47 N•m (35 lb-ft.)

Connecting Rod Bearing I.D.

Standard 48 - 48.028 mm (1.888 - 1.891 in.)
 Wear Limit 48.07 mm (1.893 in.)
 Clearance 0.038 - 0.074 mm (0.0015 - 0.0029 in.)

Piston Ring Groove Clearance

First Compression Ring
 Standard 0.075 - 0.110 mm (0.0030 - 0.0043 in.)
 Wear Limit 0.25 mm (0.0098 in.)
 Second Compression Ring
 Standard 0.045 - 0.080 mm (0.0018 - 0.0031 in.)
 Wear Limit 0.25 mm (0.0098 in.)
 Oil Ring
 Standard 0.025 - 0.060 mm (0.0010 - 0.0024 in.)
 Wear Limit 0.20 mm (0.0079 in.)

Piston Ring End Gap

Standard 0.20 - 0.40 mm (0.008 - 0.016 in.)
 Wear Limit 1.50 mm (0.0591 in.)

Piston Pin



Pin O.D.

Standard 25.987 - 26.00 mm (1.023 - 1.024 in.)
 Wear Limit 25.90 mm (1.020 in.)

Bore I.D.

Clearance 0.022 mm (0.0009 in.)
 Standard 26.00 - 26.009 mm (1.0236 - 1.0240 in.)
 Wear Limit 26.02 mm (1.024 in.)

Bushing I.D.

Clearance 0.025 - 0.051 mm (0.0009 - 0.0020 in.)
 Standard 26.025 - 26.038 mm (1.0246 - 1.0251 in.)



Piston O.D.

Distance A 23 mm (0.905 in.)

Standard Size Piston

Standard 83.94 - 83.97 mm (3.305 - 3.306 in.)
 Wear Limit 83.90 mm (3.303 in.)

0.25 mm (0.010 in.) Oversize Piston

Standard 84.19 - 84.22 mm (3.315 - 3.316 in.)
 Wear Limit 84.15 mm (3.313 in.)

Cylinder Bore I.D.

Standard Size Bore

Clearance 0.040 - 0.070 mm (0.0016 - 0.0028 in.)
 Standard 84.00 - 84.03 mm (3.307 - 3.308 in.)
 Wear Limit 84.20 mm (3.315 in.)

0.25 mm (0.010 in.) Oversize Bore

Standard 84.25 - 84.28 mm (3.317 - 3.318 in.)
 Wear Limit 84.45 mm (3.325 in.)

Deglazing 30 - 40° cross-hatch pattern

Reboring 30 - 40° cross-hatch pattern

Crankcase Extension Housing

Mounting Cap Screw Torque

Flywheel Housing/Plate-to-Extension 49 N•m (36 lb-ft.)
 Seal Case-to-Extension 26 N•m (226 lb-in.)
 Extension-to-Block 27 N•m (20 lb-ft.)
 Extension-to-Timing Gear Cover 22 N•m (195 lb-in.)

Crankshaft Rear Oil Seal

Seal Case-to-Block Cap Screw Torque 26 N•m (226 lb-in.)
 Seal Case-to-Extension Cap Screw Torque 21 N•m (180 lb-in.)

Crankshaft and Main Bearings

Main Bearing Cap Screw Torque 98 N•m (72 lb-ft.)
 Crankshaft Maximum Bend 0.02 mm (0.0007 in.)
 Connecting Rod Journal O.D.
 Standard 47.952 - 47.962 mm (1.8879 - 1.8883 in.)
 Wear Limit 47.91 mm (1.886 in.)

Main Bearing Journal O.D.

Standard 53.952 - 53.962 mm (2.124 - 2.125 in.)
 Wear Limit 53.91 mm (2.122 in.)

Main Bearing I.D.

Clearance 0.038 - 0.068 mm (0.0015 - 0.0027 in.)
 Standard 53.995 - 54.025 (2.123 - 2.127)
 Wear Limit 54.020 (2.127)

Flywheel

Maximum Distortion 0.02 mm (0.0008 in.)
 Mounting Cap Screw Torque 83 N•m (61 lb-ft.)
 Flywheel Housing/Plate Mounting Cap Screw Torque 49 N•m (36 lb-ft.)



Camshaft

Mounting Cap Screw Torque 26 N•m (226 lb-in.)
 Camshaft Side Gap

Standard 0.05 - 0.25 mm (0.0020 - 0.0098 in.)
 Maximum Camshaft Bend 0.02 mm (0.001 in.)

Lobe Height

Standard 38.635 - 38.765 mm (1.521 - 1.526 in.)
 Wear Limit 38.40 mm (1.512 in.)

Bearing Journal O.D.

Flywheel Side 44.925 - 44.950 mm (1.769 - 1.770 in.)
 Intermediate Journal 44.910 - 44.935 mm (1.768 - 1.769 in.)
 Gear Side 44.925 - 44.950 mm (1.769 - 1.770 in.)
 Wear Limit 44.850 mm (1.766 in.)
 Oil Clearance (Gear and Flywheel Ends) 0.040 - 0.130 mm (0.002 - 0.005 in.)
 Oil Clearance (Intermediate) 0.065 - 0.115 mm (0.003 - 0.005 in.)

Bushing I.D.

Clearance 0.20 mm (0.0078 in.)
 Standard 44.990 - 45.055 mm (1.771 - 1.744 in.)
 Wear Limit 45.10 mm (1.776 in.)

Bore I.D.

Clearance 0.20 mm (0.008 in.)
 Standard 45.00 - 45.025 mm (1.772 - 1.773 in.)
 Wear Limit 45.10 mm (1.776 in.)

Cam Followers

Stem O.D.

Standard 11.975 - 11.990 mm (0.471 - 0.472 in.)
 Wear Limit 11.93 mm (0.470 in.)

Bore I.D.

Clearance 0.10 mm (0.004 in.)
 Standard 12.000 - 12.018 mm (0.472 - 0.473 in.)
 Wear Limit 12.05 mm (0.474 in.)

Engine Torques, General

Cover Mounting Cap Screw Torque	26 N•m (226 lb-in.)
Crankcase Extension Housing-to-Cover Cap Screw Torque	22 N•m (195 lb-in.)
Crankshaft Pulley Cap Screw Torque	115 N•m (85 lb-ft.)
Fan Mounting Cap Screw Torque	11 N•m (226 lb-in.)
Oil Pan-to-Cover Cap Screw Torque	22 N•m (195 lb-in.)
Timing Gear Cover Mounting Plate Cap Screw Torque	25 N•m (220 lb-in.)
Oil Pan and Strainer Mounting Cap Screw Torque	26 N•m (226 lb-in.)

Idler Gear



Shaft O.D

Standard	45.950 - 45.975 mm (1.809 - 1.810 in.)
Wear Limit	45.93 mm (1.808 in.)

Bushing I.D.

Clearance	0.15 mm (0.0059 in.)
Standard	46.00 - 46.025 mm (1.811 - 1.812 in.)
Wear Limit	46.03 mm (1.812 in.)

Oil Pump

Gear Backlash

Standard	0.04 - 0.12 mm (0.002 - 0.005 in.)
Mounting Cap Screw Torque	11 N•m (8 lb-ft.)

Rotor Shaft O.D.-to-Backing Plate I.D. Clearance

Standard	0.013 - 0.043 mm (0.0005 - 0.0017 in.)
Wear Limit	0.20 mm (0.0078 in.)

Rotor Recess

Standard	0.03 - 0.09 mm (0.0011 - 0.0035 in.)
Wear Limit	0.15 mm (0.0059 in.)

Outer Rotor-to-Pump Body Clearance

Standard	0.10 - 0.16 mm (0.0039 - 0.0063 in.)
Wear Limit	0.25 mm (0.0098 in.)

Inner-to-Outer Rotor Clearance

Standard	0.05 - 0.105 mm (0.0019 - 0.0041 in.)
Wear Limit	0.15 mm (0.0059 in.)

Oil Pressure Regulating Valve

Spring

Compressed Length	27.50 mm (1.080 in.) @ 20.5 N (4.6 lb-force)
Free Length	46 mm (1.810 in.)
Housing-to-Valve Body Retaining Nut Torque	30 N•m (22 lb-ft.)
Housing-to-Engine Block Cap Screw Torque	27 N•m (20 lb-ft.)

Thermostat and Housing

Thermostat Cover Cap Screw Torque	20 N•m (180 lb-in.)
Plate-to-Housing Cap Screw Torque	9 N•m (78 lb-in.)
Housing Mounting Cap Screw Torque	26 N•m (226 lb-in.)

Water Pump

Fan Mounting Cap Screw	11 N•m (96 lb-in.)
Mounting Cap Screw Torque.....	26 N•m (226 lb-in.)
Plate-to-Housing Screw Torque.....	15 N•m (134 lb-in.)
Plug-to-Housing Torque	15 N•m (130 lb-in.)

Fuel Injection Pump

Injection Pump Gear Nut Torque.....	90 N•m (66 lb-ft.)
Mounting Nut Torque.....	26 N•m (19 lb-ft.)
Lube Line-to-Block Bolt Torque.....	25 N•m (217 lb-in.)

Fuel Injection Nozzles

Mounting Nut Torque.....	5 N•m (39 lb-in.)
Retaining Nut Torque	8 N•m (72 lb-ft.)
Separator Plate Nozzle Contact Surface Maximum Wear.....	0.10 mm (0.0039 in.)



Starter Motor - (Nippondenso 2.0 kW)

Rotation	Clockwise
No-load Amperage Draw (Max)	120
No-load Rpm (Min).....	4000
Loaded Amperage Draw (Max)	500
Minimum Brush Length	8.5 mm (0.335 in.)
Through Bolt Torque	7 - 12 N•m (62 - 106 lb-in.)
Lead Terminal Nut	6 - 10 N•m (53 - 88 lb-in.)

Alternator - Hitachi 40A

Attaching Screw Torque	4 N•m (31 lb-in.)
Rotor Assembly	
Retainer-to-Front Frame Screw Torque.....	2 N•m (16 lb-in.)
Sheave Nut Torque	49 N•m (36 lb-ft.)
End Frame-to-Rectifier Nut Torque	4 N•m (31 lb-in.)
Stator-to-Rectifier Lead Wire Distance	33.50 mm (1.300 in.)
Minimum Brush Length	5.50 mm (0.220 in.)

Checks, Tests and Adjustments

Valve Clearance	0.15 - 0.25 mm (0.006 - 0.010 in.)
-----------------------	------------------------------------

Connecting Rod Side Play

Standard Clearance	0.20 - 0.40 mm (0.0079 - 0.0157 in.)
Wear Limit	0.55 mm (0.0217 in.)

Connecting Rod Bearing Clearance

Standard Clearance	0.038 - 0.074 mm (0.0015 - 0.0029 in.)
--------------------------	--

Crankshaft End Play

Standard Clearance	0.090 - 0.271 mm (0.004 - 0.011 in.)
Wear Limit	0.33 mm (0.0129 in.)

Crankshaft Main Bearing Clearance

Main Bearing Cap Screw Torque 98 N•m (72 lb-ft.)
 Standard Clearance 0.038 - 0.068 mm (0.0015 - 0.0027 in.)

Valve Lift

Valve Lift (Intake and Exhaust) 8.8 mm (0.350 in.)

Camshaft End Play

Standard Clearance 0.05 - 0.20 mm (0.0020 - 0.0079 in.)

Timing Gear Backlash

Standard Backlash 0.04 - 0.12 mm (0.0016 - 0.0047 in.)

Fuel Injection Nozzle

Opening Pressure 21568 + 979 kPa (3128 + 142 psi)
 Leakage at 19609 kPa (2844 psi) Minimum of 5 Seconds
 Chatter and Spray Pattern at 21568 kPa (3128 psi)
 Slow Hand Lever Movement Chatter Sound
 Slow Hand Lever Movement Fine Stream Spray Pattern
 Fast Hand Lever Movement Fine Atomized Spray Pattern

Thermostat

Begin Opening 71° C (160°F)
 Fully Open 85° C (184° F)
 Minimum Lift Height (@ 85°C and above) 8 mm (0.310 in.)
 Coolant Temperature Switch Continuity 107 - 113° C (225 - 235° F)

Fuel Injection Pump Static Timing Adjustment

Injection Pump Timing 16 ± 1° BTDC
 Engine Crankshaft Position No. 1 Cylinder on TDC Compression Stroke
 Distance on Outer Surface of Flywheel Per 1° of Rotation 2.88 mm (0.110 in.)
 Timing Lines on Pump Mounting Plate 2.5° Apart

Fan/Alternator Drive Belt Tension

Applied Force 98 N (22 lb-force)
 Deflection 10 - 15 mm (0.400 - 0.600 in.)

Operational Tests

Radiator, Bubble Test

Maximum Air Pressure Into Cylinder 2158 kPa (313 psi)
 Cooling System
 Maximum Pressure 97 kPa (14 psi)
 Minimum Pressure after 15 Seconds 88 kPa (12.8 psi)



Radiator Cap

Valve Opening Pressure 88 kPa (12.8 psi)

Cylinder, Compression Pressure

Minimum Compression Pressure 2448 kPa (355 psi)
 Maximum Difference Between Cylinders 490 kPa (71 psi)

Idle Speed

Fast 3150 ± 25 rpm
 Slow 950 ± 50 rpm

Oil Pressure

Fast Idle 365 ± 69 kPa (53 ± 10 psi)
 Slow Idle 147 kPa (21 psi)

Air Intake System

Holding Pressure 34 - 69 kPa (5 - 10 psi)

Fuel Supply Pump

Minimum Pressure 29 kPa (4.3 psi)

Fuel System

Maximum Holding Pressure 103 kPa (15 psi)



SPECIFICATIONS — 3017D001 (3TNE88)

GENERAL SPECIFICATIONS

Make John Deere Series 220
 Model 3017D001
 Type Vertical, 4-cycle Diesel
 Output Power 37 HP (27 kW)
 Cylinders 3
 Bore 88 mm (3.46 in.)
 Stroke 90 mm (3.54 in.)
 Displacement 1.642 L (100.1 cu. in.)
 Firing Order 1—3—2—1
 Direction of Rotation Counterclockwise (viewed from flywheel)
 Combustion System Direct Injection Type
 Compression Ratio 18 to 1
 Cooling Liquid
 Governor Centrifugal
 RPM at Idle 900—1000
 RPM at High Idle (no-load) 3125—3175
 Rated RPM 3000
 Torque Rise 20% min

Startability

W/O Block Heater	-17.8° C
W/ Block Heater	-28.9° C

REPAIR SPECIFICATIONS

Rocker Arm Cover

Special Nut Torque	18 N•m (160 lb-in.)
--------------------------	---------------------



Rocker Arm Assembly

Mounting Cap Screw Torque	26 N•m (226 lb-in.)
Rocker Arm Shaft O.D.	
Standard	15.97 - 15.98 mm (0.6286 - 0.6293 in.)
Wear Limit	15.95 mm (0.6280 in.)
Rocker Arm and Shaft Support I.D.'s	
Clearance	0.016 mm (0.0006 in.)
Standard	16.00 - 16.02 mm (0.630 - 0.631 in.)
Wear Limit	16.09 mm (0.633 in.)
Push Rod Length	
Standard	178.25 - 178.75 mm (7.018 - 7.037 in.)
Push Rod Bend	
Standard	0.03 mm (0.001 in.) or less
Wear Limit	0.30 mm (0.012 in.)

Cylinder Head and Valves

Mounting Cap Screw Torque	
First	24 N•m (17 lb-ft.)
Second	48 N•m (36 lb-ft.)
Final	88 N•m (65 lb-ft.)
Cylinder Head Distortion	
Standard	0.05 mm (0.002 in.) or less
Wear Limit	0.15 mm (0.006 in.)
Maximum Amount of Metal to be Removed	0.20 mm (0.008 in.)
Valve Seat Width	
Intake Valve	
Standard	1.07 - 1.24 mm (0.042 - 0.049 in.)
Wear Limit	1.74 mm (0.069 in.)
Exhaust Valve	
Standard	1.24 - 1.45 mm (0.049 - 0.057 in.)
Wear Limit	1.94 mm (0.076 in.)

Intake and Exhaust Valves

Valve Faces	
Minimum Margin	0.51 mm (0.020 in.)
Exhaust Angle	45°
Intake Angle	30°

Valve Stem O.D.

Distance A	30 mm (1.181 in.)
Distance B	60 mm (2.360 in.)
Standard	7.96 - 7.98 mm (0.3134 - 0.3142 in.)
Wear Limit	7.90 mm (0.3110 in.)

Valve Recession

Standard	0.30 - 0.50 mm (0.012 - 0.020 in.)
Wear Limit	1.00 mm (0.039 in.)

Valve Guides

Valve Guide I.D.

Oil Clearance	0.035 - 0.070 mm (0.001 - 0.003 in.)
Standard	8.01 - 8.03 (0.315 - 0.316 in.)
Wear Limit	8.10 mm (0.319 in.)
Valve Guide Height	15 mm (0.591 in.)



Valve Springs

Spring Free Length

Standard	42 mm (1.655 in.)
Wear Limit	39.50 mm (1.550 in.)
Maximum Spring Inclination	1.10 mm (0.044 in.)

Exhaust Manifold

Mounting Cap Screw and Nut Torque	26 N•m (226 lb-in.)
---	---------------------

Intake Manifold

Mounting Cap Screw Torque	26 N•m (226 lb-in.)
-------------------------------------	---------------------

Valve Seat Angles

Valve Seat Surface

Exhaust Valve	45°
Intake Valve	30°
Lower Seat Surface	70°
Upper Seat Surface	15°

Piston-to-Cylinder Head Clearance

Standard	0.64 - 0.82 mm (0.025 - 0.032 in.)
--------------------	------------------------------------

Piston and Connecting Rod Cap Screw Torque 47 N•m (35 lb-ft.)

Connecting Rod Bearing I.D.

Standard	48 - 48.028 mm (1.888 - 1.891 in.)
Wear Limit	48.07 mm (1.893 in.)
Clearance	0.038 - 0.074 mm (0.0015 - 0.0029 in.)

Piston Ring Groove Clearance

First Compression Ring

Standard 0.070 - 0.105 mm (0.0028 - 0.0041 in.)
 Wear Limit 0.25 mm (0.0098 in.)

Second Compression Ring

Standard 0.035 - 0.070 mm (0.0014 - 0.0028 in.)
 Wear Limit 0.25 mm (0.0098 in.)

Oil Ring

Standard 0.025 - 0.060 mm (0.0010 - 0.0024 in.)
 Wear Limit 0.20 mm (0.0079 in.)



Piston Ring End Gap

Standard 0.20 - 0.40 mm (0.008 - 0.016 in.)
 Wear Limit 1.50 mm (0.0591 in.)

Piston Pin

Pin O.D.

Standard 25.987 - 26.00 mm (1.023 - 1.024 in.)
 Wear Limit 25.90 mm (1.020 in.)

Bore I.D.

Clearance 0.022 mm (0.0009 in.)
 Standard 26.000 - 26.009 mm (1.0236 - 1.0240 in.)
 Wear Limit 26.02 mm (1.024 in.)

Bushing I.D.

Clearance 0.025 - 0.051 mm (0.0009 - 0.002 in.)
 Standard 26.025 - 26.038 mm (1.0246 - 1.0251 in.)

Piston O.D.

Distance A 23 mm (0.905 in.)

Standard Size Piston

Standard 87.945 - 87.975 mm (3.462 - 3.464 in.)
 Wear Limit 87.90 mm (3.461 in.)

0.25 mm (0.010 in.) Oversize Piston

Standard 88.195 - 88.225 mm (3.472 - 3.473 in.)
 Wear Limit 88.150 mm (3.470 in.)

Cylinder Bore I.D.

Standard Size Bore

Clearance 0.040 - 0.070 mm (0.0016 - 0.0028 in.)
 Standard 88.00 - 88.03 mm (3.465 - 3.466 in.)
 Wear Limit 88.20 mm (3.472 in.)

0.25 mm (0.010 in.) Oversize Bore

Standard 88.25 - 88.28 mm (3.474 - 3.476 in.)
 Wear Limit 88.20 mm (3.472 in.)

Deglazing 30 - 40° cross-hatch pattern

Reboring 30 - 40° cross-hatch pattern

Crankcase Extension Housing

Mounting Cap Screw Torque

Flywheel Housing/Plate-to-Extension 49 N•m (36 lb-ft.)
 Seal Case-to-Extension 26 N•m (226 lb-in.)
 Extension-to-Block 27 N•m (20 lb-ft.)
 Extension-to-Timing Gear Cover 22 N•m (195 lb-in.)

Crankshaft Rear Oil Seal

Seal Case-to-Block Cap Screw Torque 26 N•m (226 lb-in.)
 Seal Case-to-Extension Cap Screw Torque 21 N•m (180 lb-in.)



Crankshaft and Main Bearings

Main Bearing Cap Screw Torque 98 N•m (72 lb-ft.)
 Crankshaft Maximum Bend 0.02 mm (0.0007 in.)
 Connecting Rod Journal O.D.
 Standard. 47.952 - 47.962 mm (1.8879 - 1.8883 in.)
 Wear Limit 47.91 mm (1.886 in.)
 Main Bearing Journal O.D.
 Standard. 53.952 - 53.962 mm (2.124 - 2.125 in.)
 Wear Limit 53.91 mm (2.122 in.)
 Main Bearing I.D.
 Clearance 0.038 - 0.068 mm (0.0015 - 0.0027 in.)
 Standard. 53.995 - 54.025 (2.123 - 2.127)
 Wear Limit 54.020 (2.127)

Flywheel

Maximum Distortion 0.02 mm (0.0008 in.)
 Mounting Cap Screw Torque 83 N•m (61 lb-ft.)
 Flywheel Housing/Plate Mounting Cap Screw Torque 49 N•m (36 lb-ft.)

Camshaft

Mounting Cap Screw Torque 26 N•m (226 lb-in.)
 Camshaft Side Gap
 Standard. 0.05 - 0.25 mm (0.0020 - 0.0098 in.)
 Maximum Camshaft Bend 0.02 mm (0.001 in.)
 Lobe Height
 Standard. 38.635 - 38.765 mm (1.521 - 1.526 in.)
 Wear Limit 38.40 mm (1.512 in.)
 Bearing Journal O.D.
 Flywheel Side 44.925 - 44.950 mm (1.769 - 1.770 in.)
 Intermediate Journal 44.910 - 44.935 mm (1.768 - 1.769 in.)
 Gear Side 44.925 - 44.950 mm (1.769 - 1.770 in.)
 Wear Limit 44.850 mm (1.766 in.)
 Oil Clearance (Gear and Flywheel Ends) . . . 0.040 - 0.130 mm (0.002 - 0.005 in.)
 Oil Clearance (Intermediate) 0.065 - 0.115 mm (0.003 - 0.005 in.)
 Bushing I.D.

Clearance	0.20 mm (0.0078 in.)
Standard	44.990 - 45.055 mm (1.771 - 1.744 in.)
Wear Limit	45.10 mm (1.776 in.)
Bore I.D.	
Clearance	0.20 mm (0.008 in.)
Standard	45.00 - 45.025 mm (1.772 - 1.773 in.)
Wear Limit	45.10 mm (1.776 in.)

Cam Followers



Stem O.D.	
Standard	11.975 - 11.990 mm (0.471 - 0.472 in.)
Wear Limit	11.93 mm (0.470 in.)
Bore I.D.	
Clearance	0.10 mm (0.004 in.)
Standard	12.000 - 12.018 mm (0.472 - 0.473 in.)
Wear Limit	12.05 mm (0.474 in.)

Engine Torques, General

Cover Mounting Cap Screw Torque	26 N•m (226 lb-in.)
Crankcase Extension Housing-to-Cover Cap Screw Torque	22 N•m (195 lb-in.)
Crankshaft Pulley Cap Screw Torque	115 N•m (85 lb-ft.)
Fan Mounting Cap Screw Torque	11 N•m (226 lb-in.)
Oil Pan-to-Cover Cap Screw Torque	22 N•m (195 lb-in.)
Timing Gear Cover Mounting Plate Cap Screw Torque	25 N•m (220 lb-in.)
Oil Pan and Strainer Mounting Cap Screw Torque	26 N•m (226 lb-in.)

Idler Gear

Shaft O.D	
Standard	45.950 - 45.975 mm (1.809 - 1.810 in.)
Wear Limit	45.93 mm (1.808 in.)
Bushing I.D.	
Clearance	0.15 mm (0.0059 in.)
Standard	46.000 - 46.025 mm (1.811 - 1.812 in.)
Wear Limit	46.030 mm (1.812 in.)

Oil Pump

Gear Backlash	
Standard	0.04 - 0.12 mm (0.002 - 0.005 in.)
Mounting Cap Screw Torque	11 N•m (8 lb-ft.)
Rotor Shaft O.D.-to-Backing Plate I.D. Clearance	
Standard	0.013 - 0.043 mm (0.0005 - 0.0017 in.)
Wear Limit	0.20 mm (0.0078 in.)
Rotor Recess	
Standard	0.03 - 0.09 mm (0.0011 - 0.0035 in.)
Wear Limit	0.15 mm (0.0059 in.)
Outer Rotor-to-Pump Body Clearance	

Standard	0.10 - 0.16 mm (0.0039 - 0.0063 in.)
Wear Limit	0.25 mm (0.0098 in.)
Inner-to-Outer Rotor Clearance	
Standard	0.05 - 0.105 mm (0.0019 - 0.0041 in.)
Wear Limit	0.15 mm (0.0059 in.)

Oil Pressure Regulating Valve

Spring

Compressed Length	27.50 mm (1.080 in.) @ 20.5 N (4.6 lb-force)
Free Length	46 mm (1.810 in.)
Housing-to-Valve Body Retaining Nut Torque	30 N•m (22 lb-ft.)
Housing-to-Engine Block Cap Screw Torque	27 N•m (20 lb-ft.)



Thermostat and Housing

Thermostat Cover Cap Screw Torque	20 N•m (180 lb-in.)
Plate-to-Housing Cap Screw Torque	9 N•m (78 lb-in.)
Housing Mounting Cap Screw Torque	26 N•m (226 lb-in.)

Water Pump

Fan Mounting Cap Screw	11 N•m (96 lb-in.)
Mounting Cap Screw Torque	26 N•m (226 lb-in.)
Plate-to-Housing Screw Torque	15 N•m (134 lb-in.)
Plug-to-Housing Torque	15 N•m (130 lb-in.)

Fuel Injection Pump

Injection Pump Gear Nut Torque	90 N•m (66 lb-ft.)
Mounting Nut Torque	26 N•m (19 lb-ft.)
Lube Line-to-Block Bolt Torque	25 N•m (217 lb-in.)

Fuel Injection Nozzles

Mounting Nut Torque	5 N•m (39 lb-in.)
Retaining Nut Torque	8 N•m (72 lb-ft.)
Separator Plate Nozzle Contact Surface Maximum Wear	0.10 mm (0.0039 in.)

Starter Motor - (Nippondenso 1.4 kW)

Rotation	Clockwise
No-load Amperage Draw (Max)	90
No-load Rpm (Min)	3500
Loaded Amperage Draw (Max)	350
Minimum Brush Length	8.5 mm (0.335 in.)
Through Bolt Torque	7 - 12 N•m (62 - 106 lb-in.)
Lead Terminal Nut	6 - 10 N•m (53 - 88 lb-in.)

Alternator - Hitachi 40A

Attaching Screw Torque	4 N•m (31 lb-in.)
Rotor Assembly	
Retainer-to-Front Frame Screw Torque	2 N•m (16 lb-in.)
Sheave Nut Torque	49 N•m (36 lb-ft.)

End Frame-to-Rectifier Nut Torque 4 N•m (31 lb-in.)
 Stator-to-Rectifier Lead Wire Distance 33.50 mm (1.300 in.)
 Minimum Brush Length 5.50 mm (0.220 in.)

Checks, Tests and Adjustments

Valve Clearance 0.15 - 0.25 mm (0.006 - 0.010 in.)

Connecting Rod Side Play

Standard Clearance 0.20 - 0.40 mm (0.0079 - 0.0157 in.)
 Wear Limit 0.55 mm (0.0217 in.)



Connecting Rod Bearing Clearance

Standard Clearance 0.038 - 0.074 mm (0.0015 - 0.0029 in.)

Crankshaft End Play

Standard Clearance 0.090 - 0.271 mm (0.004 - 0.011 in.)
 Wear Limit 0.33 mm (0.0129 in.)

Crankshaft Main Bearing Clearance

Main Bearing Cap Screw Torque 98 N•m (72 lb-ft.)
 Standard Clearance 0.038 - 0.068 mm (0.0015 - 0.0027 in.)

Valve Lift

Valve Lift (Intake and Exhaust) 8.8 mm (0.350 in.)

Camshaft End Play

Standard Clearance 0.05 - 0.25 mm (0.0020 - 0.0098 in.)

Timing Gear Backlash

Standard Backlash 0.04 - 0.12 mm (0.0016 - 0.0047 in.)

Fuel Injection Nozzle

Opening Pressure 21568 + 979 kPa (3128 + 142 psi)
 Leakage at 19609 kPa (2844 psi) Minimum of 5 Seconds
 Chatter and Spray Pattern at 21568 kPa (3128 psi)
 Slow Hand Lever Movement Chatter Sound
 Slow Hand Lever Movement Fine Stream Spray Pattern
 Fast Hand Lever Movement Fine Atomized Spray Pattern

Thermostat

Begin Opening 71° C (160°F)
 Fully Open 85° C (184° F)
 Minimum Lift Height (@ 85°C and above) 8 mm (0.310 in.)

Coolant Temperature Switch Continuity 107 - 113° C (225 - 235° F)

Fuel Injection Pump Static Timing Adjustment

Injection Pump Timing

. 16 ± 1° BTDC
 Engine Crankshaft Position No. 1 Cylinder on TDC Compression Stroke
 Distance on Outer Surface of Flywheel Per 1° of Rotation . . . 2.88 mm (0.110 in.)
 Timing Lines on Pump Mounting Plate 2.5° Apart

Fan/Alternator Drive Belt Tension

Applied Force 98 N (22 lb-force)
 Deflection 10 - 15 mm (0.400 - 0.600 in.)



Operational Tests

Radiator, Bubble Test

Maximum Air Pressure Into Cylinder 2158 kPa (313 psi)
 Cooling System
 Maximum Pressure 97 kPa (14 psi)
 Minimum Pressure after 15 Seconds 88 kPa (12.8 psi)

Radiator Cap

Valve Opening Pressure 88 kPa (12.8 psi)

Cylinder, Compression Pressure

Minimum Compression Pressure 2448 kPa (355 psi)
 Maximum Difference Between Cylinders 490 kPa (71 psi)

Idle Speed

Fast 3150 ± 25 rpm
 Slow 950 ± 50 rpm

Oil Pressure

Fast Idle 365 ± 69 kPa (53 ± 10 psi)
 Slow Idle 147 kPa (21 psi)

Air Intake System Holding Pressure 34 - 69 kPa (5 - 10 psi)

Minimum Fuel Supply Pump Pressure 29 kPa (4.3 psi)

Fuel System Holding Pressure (Maximum) 103 kPa (15 psi)

SPECIFICATIONS - 4022D001 (4TNE88)

GENERAL SPECIFICATIONS



Make	John Deere Series 220
Model	4022D001
Type	Vertical, 4-cycle Diesel
Output Power @2800 RPM	34 kW 46 HP)
Cylinders	4
Bore	88 mm (3.46 in.)
Stroke	90 mm(3.54 in.)
Displacement	2.189 L(137 cu. in.)
Firing Order	1—3—4—2
Direction of Rotation	Counterclockwise (viewed from flywheel)
Combustion System	Direct Injection Type
Compression Ratio	18 to 1
Cooling	Liquid
Governor	Centrifugal
RPM at Idle	900—1000
RPM at High Idle (no-load)	3125—3175
Rated RPM	3000
Torque Rise	20% min

Startability

W/O Block Heater	-17.8° C
W/ Block Heater	-28.9° C

REPAIR SPECIFICATIONS

Rocker Arm Cover

Special Nut Torque	18 N•m (160 lb-in.)
--------------------------	---------------------

Rocker Arm Assembly

Mounting Cap Screw Torque	26 N•m (226 lb-in.)
Rocker Arm Shaft O.D.	
Standard	15.97 - 15.98 mm (0.6286 - 0.6293 in.)
Wear Limit	15.95 mm (0.6280 in.)
Rocker Arm and Shaft Support I.D.'s	
Clearance	0.016 mm (0.0006 in.)
Standard	16.00 - 16.02 mm (0.630 - 0.631 in.)
Wear Limit	16.09 mm (0.633 in.)
Push Rod Length	
Standard	178.25 - 178.75 mm (7.018 - 7.037 in.)
Push Rod Bend	
Standard	0.03 mm (0.001 in.) or less
Wear Limit	0.30 mm (0.012 in.)

Cylinder Head and Valves

Mounting Cap Screw Torque

First	24 N•m (17 lb-ft.)
Second	48 N•m (36 lb-ft.)
Final	88 N•m (65 lb-ft.)

Cylinder Head Distortion

Standard	0.05 mm (0.002 in.) or less
Wear Limit	0.15 mm (0.006 in.)
Maximum Amount of Metal to be Removed	0.20 mm (0.008 in.)

Valve Seat Width

Intake Valve	
Standard	1.07 - 1.24 mm (0.042 - 0.049 in.)
Wear Limit	1.74 mm (0.069 in.)
Exhaust Valve	
Standard	1.24 - 1.45 mm (0.049 - 0.057 in.)
Wear Limit	1.94 mm (0.076 in.)



Intake and Exhaust Valves

Valve Faces

Minimum Margin	0.51 mm (0.020 in.)
Exhaust Angle	45°
Intake Angle	30°

Valve Stem O.D.

Distance A	30 mm (1.181 in.)
Distance B	60 mm (2.360 in.)

Head Size, Intake and Exhaust Valves

Standard	7.96 - 7.98 mm (0.3134 - 0.3142 in.)
Wear Limit	7.90 mm (0.3110 in.)

Valve Recession

Standard	0.30 - 0.50 mm (0.012 - 0.020 in.)
Wear Limit	1.00 mm (0.039 in.)

Valve Guides

Valve Guide I.D.

Oil Clearance	0.035 - 0.070 mm (0.001 - 0.003 in.)
Standard	8.01 - 8.03 (0.315 - 0.316 in.)
Wear Limit	8.10 mm (0.319 in.)
Valve Guide Height	15 mm (0.591 in.)

Valve Springs

Spring Free Length

Standard	42 mm (1.655 in.)
Wear Limit	39.50 mm (1.550 in.)
Maximum Spring Inclination	1.10 mm (0.044 in.)

Exhaust Manifold

Mounting Cap Screw and Nut Torque	26 N•m (226 lb-in.)
---	---------------------

Intake Manifold

Mounting Cap Screw Torque 26 N•m (226 lb-in.)

Valve Seat Angles

Valve Seat Surface

Exhaust Valve 45°
 Intake Valve 30°
 Lower Seat Surface 70°
 Upper Seat Surface 15°



Piston-to-Cylinder Head Clearance

Standard 0.64 - 0.82 mm (0.025 - 0.032 in.)

Piston and Connecting Rod Cap Screw Torque 39 N•m (29 lb-ft.)

Connecting Rod Bearing I.D.

Standard 48 - 48.028 mm (1.888 - 1.891 in.)
 Wear Limit 48.07 mm (1.893 in.)
 Clearance 0.038 - 0.074 mm (0.0015 - 0.0029 in.)

Piston Ring Groove Clearance

First Compression Ring

Standard 0.070 - 0.105 mm (0.0028 - 0.0041 in.)
 Wear Limit 0.25 mm (0.0098 in.)

Second Compression Ring

Standard 0.035 - 0.070 mm (0.0014 - 0.0028 in.)
 Wear Limit 0.25 mm (0.0098 in.)

Oil Ring

Standard 0.030 - 0.060 mm (0.0012 - 0.0024 in.)
 Wear Limit 0.20 mm (0.0078 in.)

Piston Ring End Gap

Standard 0.20 - 0.40 mm (0.008 - 0.016 in.)
 Wear Limit 1.50 mm (0.0591 in.)

Piston Pin

Pin O.D.

Standard 25.987 - 26.00 mm (1.023 - 1.024 in.)
 Wear Limit 25.90 mm (1.020 in.)

Bore I.D.

Clearance 0.022 mm (0.0009 in.)
 Standard 26.00 - 26.009 mm (1.0236 - 1.0240 in.)
 Wear Limit 26.02 mm (1.024 in.)

Bushing I.D.

Clearance 0.025 - 0.051 mm (0.0009 - 0.0020 in.)
 Standard 26.025 - 26.038 mm (1.0246 - 1.0251 in.)

Piston O.D.

Distance A	23 mm (0.905 in.)
Standard Size Piston	
Standard	87.945 - 87.975 mm (3.462 - 3.464 in.)
Wear Limit	87.90 mm (3.461 in.)
0.25 mm (0.010 in.) Oversize Piston	
Standard	88.195- 88.225 mm (3.472 - 3.473 in.)
Wear Limit	88.15 mm (3.470 in.)

Cylinder Bore I.D.

Standard Size Bore

Clearance	0.040 - 0.070 mm (0.0016 - 0.0028 in.)
Standard	88.00 - 88.03 mm (3.464 - 3.467 in.)
Wear Limit	88.20 mm (3.472 in.)
0.25 mm (0.010 in.) Oversize Bore	
Standard	88.25 - 88.28 mm (3.474 - 3.476 in.)
Wear Limit	88.45 mm (3.482 in.)
Deglazing	30 - 40° cross-hatch pattern
Reboring	30 - 40° cross-hatch pattern



Crankcase Extension Housing

Mounting Cap Screw Torque

Flywheel Housing/Plate-to-Extension	49 N•m (36 lb-ft.)
Seal Case-to-Extension	26 N•m (226 lb-in.)
Extension-to-Block	27 N•m (20 lb-ft.)
Extension-to-Timing Gear Cover	22 N•m (195 lb-in.)

Crankshaft Rear Oil Seal

Seal Case-to-Block Cap Screw Torque	26 N•m (226 lb-in.)
Seal Case-to-Extension Cap Screw Torque	21 N•m (180 lb-in.)

Crankshaft and Main Bearings

Main Bearing Cap Screw Torque	98 N•m (72 lb-ft.)
Crankshaft Maximum Bend	0.02 mm (0.0007 in.)
Connecting Rod Journal O.D.	
Standard	47.952 - 47.962 mm (1.8879 - 1.8883 in.)
Wear Limit	47.91 mm (1.886 in.)
Main Bearing Journal O.D.	
Standard	53.952 - 53.962 mm (2.124 - 2.125 in.)
Wear Limit	53.91 mm (2.122 in.)
Main Bearing I.D.	
Clearance	0.038 - 0.068 mm (0.0015 - 0.0027 in.)
Standard	53.995 - 54.025 (2.123 - 2.127)
Wear Limit	54.020 (2.127)

Flywheel

Maximum Distortion	0.02 mm (0.0008 in.)
Mounting Cap Screw Torque	83 N•m (61 lb-ft.)
Flywheel Housing/Plate Mounting Cap Screw Torque	49 N•m (36 lb-ft.)

Camshaft

Mounting Cap Screw Torque	26 N•m (226 lb-in.)
Camshaft Side Gap	
Standard	0.05 - 0.25 mm (0.0020 - 0.0098 in.)
Maximum Camshaft Bend	0.02 mm (0.001 in.)
Lobe Height	
Standard	38.635 - 38.765 mm (1.521 - 1.526 in.)
Wear Limit	38.40 mm (1.512 in.)
Bearing Journal O.D.	
Flywheel Side	44.925 - 44.950 mm (1.769 - 1.770 in.)
Intermediate Journal	44.910 - 44.935 mm (1.768 - 1.769 in.)
Gear Side	44.925 - 44.950 mm (1.769 - 1.770 in.)
Wear Limit	44.850 mm (1.766 in.)
Oil Clearance (Gear and Flywheel Ends)	0.040 - 0.130 mm (0.002 - 0.005 in.)
Oil Clearance (Intermediate)	0.065 - 0.115 mm (0.003 - 0.005 in.)
Bushing I.D.	
Clearance	0.20 mm (0.0078 in.)
Standard	44.990 - 45.055 mm (1.771 - 1.744 in.)
Wear Limit	45.10 mm (1.776 in.)
Bore I.D.	
Clearance	0.20 mm (0.008 in.)
Standard	45.00 - 45.025 mm (1.772 - 1.773 in.)
Wear Limit	45.10 mm (1.776 in.)



Cam Followers

Stem O.D.	
Standard	11.975 - 11.990 mm (0.471 - 0.472 in.)
Wear Limit	11.93 mm (0.470 in.)
Bore I.D.	
Clearance	0.10 mm (0.004 in.)
Standard	12.000 - 12.018 mm (0.472 - 0.473 in.)
Wear Limit	12.05 mm (0.474 in.)

Engine Torques, General

Cover Mounting Cap Screw Torque	26 N•m (226 lb-in.)
Crankcase Extension Housing-to-Cover Cap Screw Torque	22 N•m (195 lb-in.)
Crankshaft Pulley Cap Screw Torque	115 N•m (85 lb-ft.)
Fan Mounting Cap Screw Torque	11 N•m (226 lb-in.)
Oil Pan-to-Cover Cap Screw Torque	22 N•m (195 lb-in.)
Timing Gear Cover Mounting Plate Cap Screw Torque	25 N•m (220 lb-in.)
Oil Pan and Strainer Mounting Cap Screw Torque	26 N•m (226 lb-in.)

Idler Gear

Shaft O.D.	
Standard	45.950 - 45.975 mm (1.809 - 1.810 in.)
Wear Limit	45.93 mm (1.808 in.)
Bushing I.D.	
Clearance	0.15 mm (0.0059 in.)
Standard	46.00 - 46.025 mm (1.811 - 1.812 in.)

Wear Limit 46.03 mm (1.812 in.)

Oil Pump

Gear Backlash

Standard 0.04 - 0.12 mm (0.002 - 0.005 in.)

Mounting Cap Screw Torque 11 N•m (8 lb-ft.)

Rotor Shaft O.D.-to-Backing Plate I.D. Clearance

Standard 0.013 - 0.043 mm (0.0005 - 0.0017 in.)

Wear Limit 0.20 mm (0.0078 in.)

Rotor Recess

Standard 0.03 - 0.09 mm (0.0011 - 0.0035 in.)

Wear Limit 0.15 mm (0.0059 in.)

Outer Rotor-to-Pump Body Clearance

Standard 0.10 - 0.16 mm (0.0039 - 0.0063 in.)

Wear Limit 0.25 mm (0.0098 in.)

Inner-to-Outer Rotor Clearance

Standard 0.05 - 0.105 mm (0.0019 - 0.0041 in.)

Wear Limit 0.15 mm (0.0059 in.)

Oil Pressure Regulating Valve

Spring

Compressed Length 27.50 mm (1.080 in.) @ 20.5 N (4.6 lb-force)

Free Length 46 mm (1.810 in.)

Housing-to-Valve Body Retaining Nut Torque 30 N•m (22 lb-ft.)

Housing-to-Engine Block Cap Screw Torque 27 N•m (20 lb-ft.)

Thermostat and Housing

Thermostat Cover Cap Screw Torque 20 N•m (180 lb-in.)

Plate-to-Housing Cap Screw Torque 9 N•m (78 lb-in.)

Housing Mounting Cap Screw Torque 26 N•m (226 lb-in.)

Water Pump

Fan Mounting Cap Screw 11 N•m (96 lb-in.)

Mounting Cap Screw Torque 26 N•m (226 lb-in.)

Plate-to-Housing Screw Torque 15 N•m (134 lb-in.)

Plug-to-Housing Torque 15 N•m (130 lb-in.)

Fuel Injection Pump

Injection Pump Gear Nut Torque 90 N•m (66 lb-ft.)

Mounting Nut Torque 26 N•m (19 lb-ft.)

Lube Line-to-Block Bolt Torque 25 N•m (217 lb-in.)

Fuel Injection Nozzles

Mounting Nut Torque 5 N•m (39 lb-in.)

Retaining Nut Torque 8 N•m (72 lb-ft.)

Separator Plate Nozzle Contact Surface Maximum Wear 0.10 mm (0.0039 in.)



Starter Motor - (Nippondenso 2.0 kW)

Rotation	Clockwise
No-load Amperage Draw (Max)	120
No-load Rpm (Min)	4000
Loaded Amperage Draw (Max)	500
Minimum Brush Length	8.5 mm (0.335 in.)
Through Bolt Torque	7 - 12 N•m (62 - 106 lb-in.)
Lead Terminal Nut	6 - 10 N•m (53 - 88 lb-in.)

Alternator - Hitachi 40A



Attaching Screw Torque	4 N•m (31 lb-in.)
Rotor Assembly	
Retainer-to-Front Frame Screw Torque	2 N•m (16 lb-in.)
Sheave Nut Torque	49 N•m (36 lb-ft.)
End Frame-to-Rectifier Nut Torque	4 N•m (31 lb-in.)
Stator-to-Rectifier Lead Wire Distance	33.50 mm (1.300 in.)
Minimum Brush Length	5.50 mm (0.220 in.)

Checks, Tests and Adjustments

Valve Clearance	0.15 - 0.25 mm (0.006 - 0.010 in.)
---------------------------	------------------------------------

Connecting Rod Side Play

Standard Clearance	0.20 - 0.40 mm (0.0079 - 0.0157 in.)
Wear Limit	0.55 mm (0.0217 in.)

Connecting Rod Bearing Clearance

Standard Clearance	0.038 - 0.074 mm (0.0015 - 0.0029 in.)
------------------------------	--

Crankshaft End Play

Standard Clearance	0.090 - 0.271 mm (0.004 - 0.011 in.)
Wear Limit	0.33 mm (0.0129 in.)

Crankshaft Main Bearing Clearance

Main Bearing Cap Screw Torque	98 N•m (72 lb-ft.)
Standard Clearance	0.038 - 0.068 mm (0.0015 - 0.0027 in.)

Valve Lift

Valve Lift (Intake and Exhaust)	8.8 mm (0.350 in.)
---	--------------------

Camshaft End Play

Standard Clearance	0.05 - 0.20 mm (0.0020 - 0.0079 in.)
Wear Limit	0.40 mm (0.016 in.)

Timing Gear Backlash

Standard Backlash	0.04 - 0.12 mm (0.0016 - 0.0047 in.)
-----------------------------	--------------------------------------

Fuel Injection Nozzle

Opening Pressure 21568 + 979 kPa (3128 + 142 psi)
 Leakage at 19609 kPa (2844 psi) Minimum of 5 Seconds
 Chatter and Spray Pattern at 21568 kPa (3128 psi)
 Slow Hand Lever Movement Chatter Sound
 Slow Hand Lever Movement Fine Stream Spray Pattern
 Fast Hand Lever Movement Fine Atomized Spray Pattern

Thermostat

Begin Opening 71° C (160°F)
 Fully Open 85° C (184° F)
 Minimum Lift Height (@ 85°C and above) 8 mm (0.310 in.)
 Coolant Temperature Switch Continuity 107 - 113° C (225 - 235° F)



Fuel Injection Pump Static Timing Adjustment

Injection Pump Timing 14° BTDC
 Engine Crankshaft Position No. 1 Cylinder on TDC Compression Stroke
 Distance on Outer Surface of Flywheel Per 1° of Rotation 2.88 mm (0.110 in.)
 Timing Lines on Pump Mounting Plate 2.5° Apart

Fan/Alternator Drive Belt Tension

Applied Force 98 N (22 lb-force)
 Deflection 10 - 15 mm (0.400 - 0.600 in.)

Operational Tests

Radiator, Bubble Test

Maximum Air Pressure Into Cylinder 2158 kPa (313 psi)
 Cooling System
 Maximum Pressure 97 kPa (14 psi)
 Minimum Pressure after 15 Seconds 88 kPa (12.8 psi)

Radiator Cap

Valve Opening Pressure 88 kPa (12.8 psi)

Cylinder, Compression Pressure

Minimum Compression Pressure 2448 kPa (355 psi)
 Maximum Difference Between Cylinders 490 kPa (71 psi)

Idle Speed

Fast 3150 ± 25 rpm
 Slow 950 ± 50 rpm

Oil Pressure

Fast Idle 365 ± 69 kPa (53 ± 10 psi)
 Slow Idle 147 kPa (21 psi)

Air Intake System

Holding Pressure 34 - 69 kPa (5 - 10 psi)

Fuel System

Minimum Fuel Pump Pressure 29 kPa (4.3 psi)

Maximum Fuel System Holding Pressure 103 kPa (15 psi)

ENGINE COMPONENT LOCATION

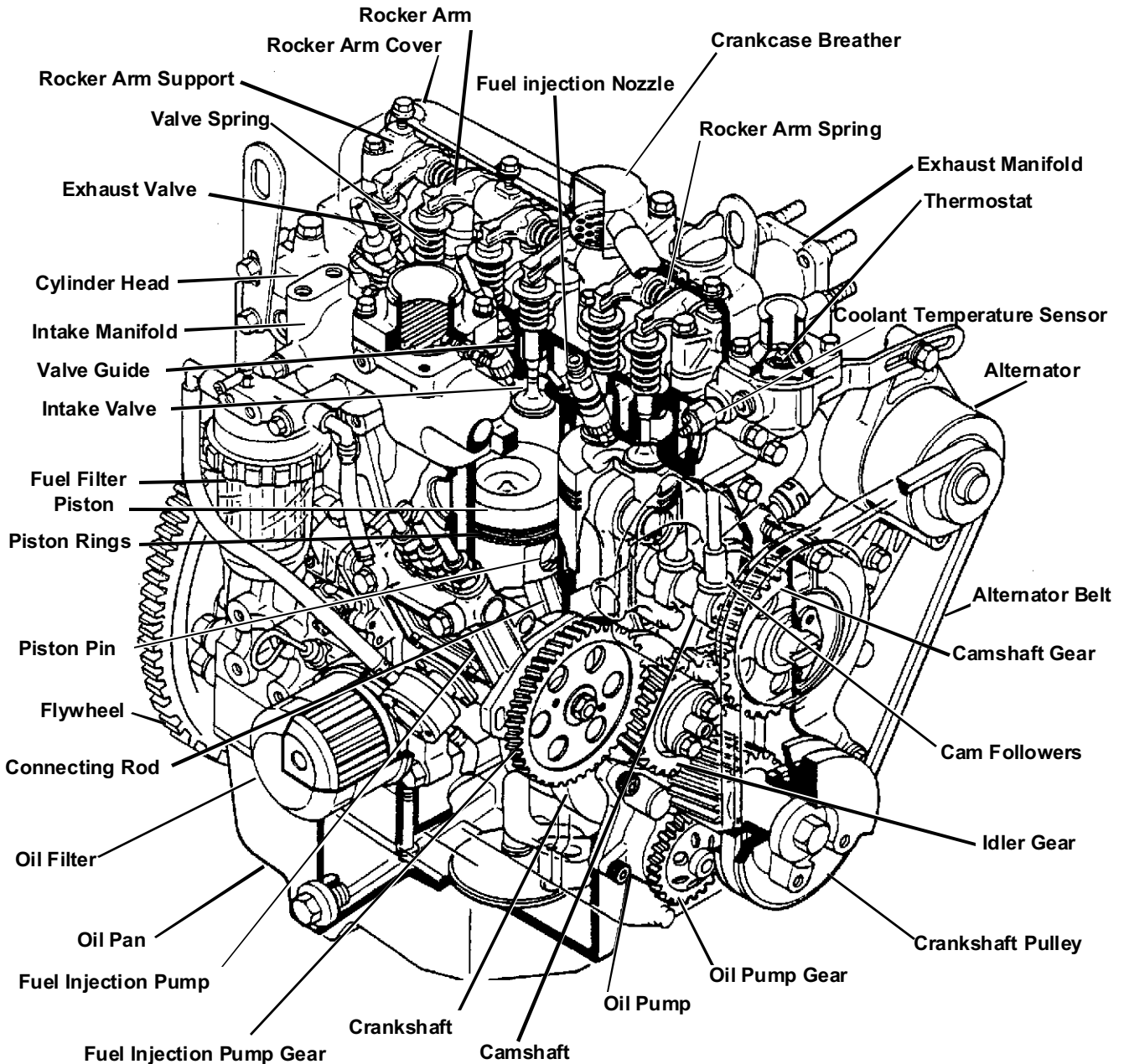

M56589

THEORY OF OPERATION

COOLING SYSTEM OPERATION

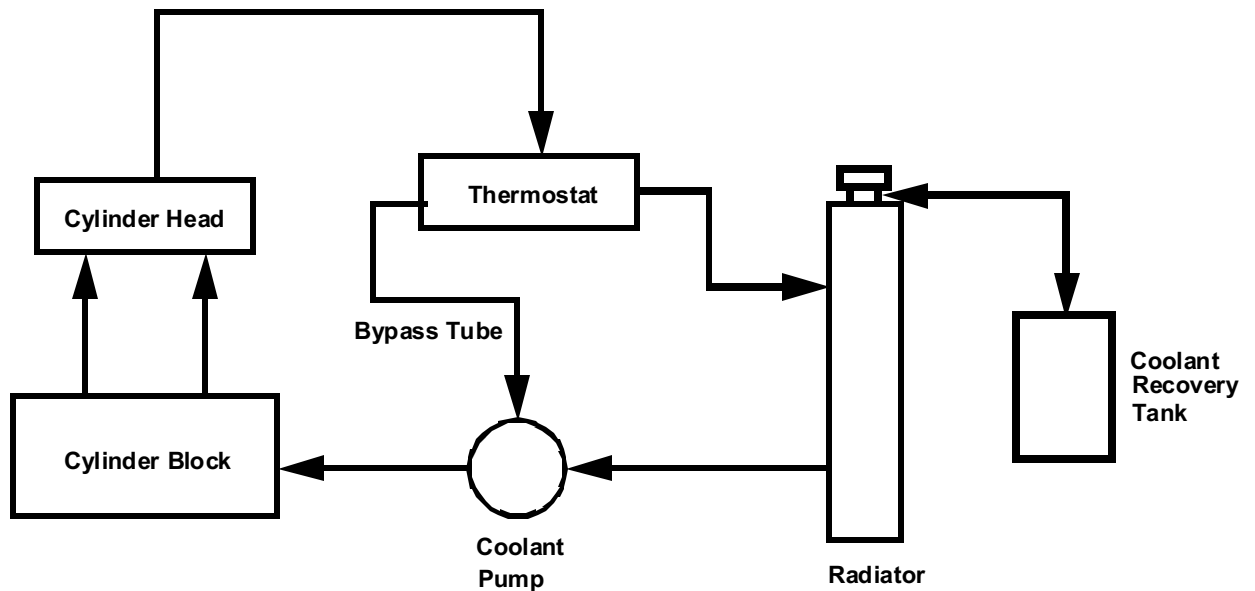
**Function:**

The coolant pump circulates coolant through the cooling system, drawing hot coolant from the engine block, circulating it through the radiator for cooling.

Theory of Operation:

The pressurized cooling system includes the radiator, water pump, fan and thermostat.

During the warm-up period, the thermostat remains closed and the impeller type coolant pump draws coolant from the bypass tube. Coolant from the pump flows to the cylinder block water jacket and up through the cylinder head providing a fast warm-up period.

Once the engine has reached operating temperature, the thermostat opens and coolant is pumped from the bottom of the radiator via the lower radiator hose into the cylinder block. Here it circulates through the block and around the cylinders.

From the block, coolant is then directed through the cylinder head, and into thermostat housing. With the thermostat open, **82° C (180° F)**, warm engine coolant passes through the housing into the top of the radiator where it is circulated to dissipate heat.

When coolant system pressure exceeds **48 kPa (7 psi)**, a valve in the radiator cap opens to allow coolant to discharge into the coolant recovery tank.

When temperature is reduced, a vacuum is produced in the radiator and coolant is drawn back out of the coolant recovery tank through a valve in the radiator cap.

A coolant temperature sensor informs the operator of the engine coolant temperature and warns of a high temperature condition by lighting a lamp.

LUBRICATION SYSTEM OPERATION

Function:

A full pressure system lubricates engine parts with clean oil.

Theory of Operation:

The pressure lubrication system consists of a positive displacement gear-driven pump, oil strainer, full flow oil filter, oil pressure regulating valve and an electrical pressure warning switch.



The pump draws lubrication oil from the oil pan through a strainer and a suction tube. The oil is then pumped through an oil passage to the oil filter and through the engine block main oil galley.

From the main oil galley, oil is forwarded under pressure to the crankshaft main bearing journals and idler gear shaft. Drilled cross-passages in the crankshaft distribute the oil from the main bearings to connecting rod bearings.

Lube oil holes in main bearing oil grooves are provided to direct oil to the camshaft bearings.

A drilled passage from the rear camshaft bearing through the cylinder block and cylinder head supplies lubricating oil to the rocker arm shaft. The hollow shaft distributes oil to the rocker arms, tappets and valves.

Oil passages direct from the main oil galley, through external oil lines, route lubricating oil to the fuel injection pump.

An oil pressure switch activates an indicator light to alert the operator to shut down the engine if oil pressure drops below a specification.

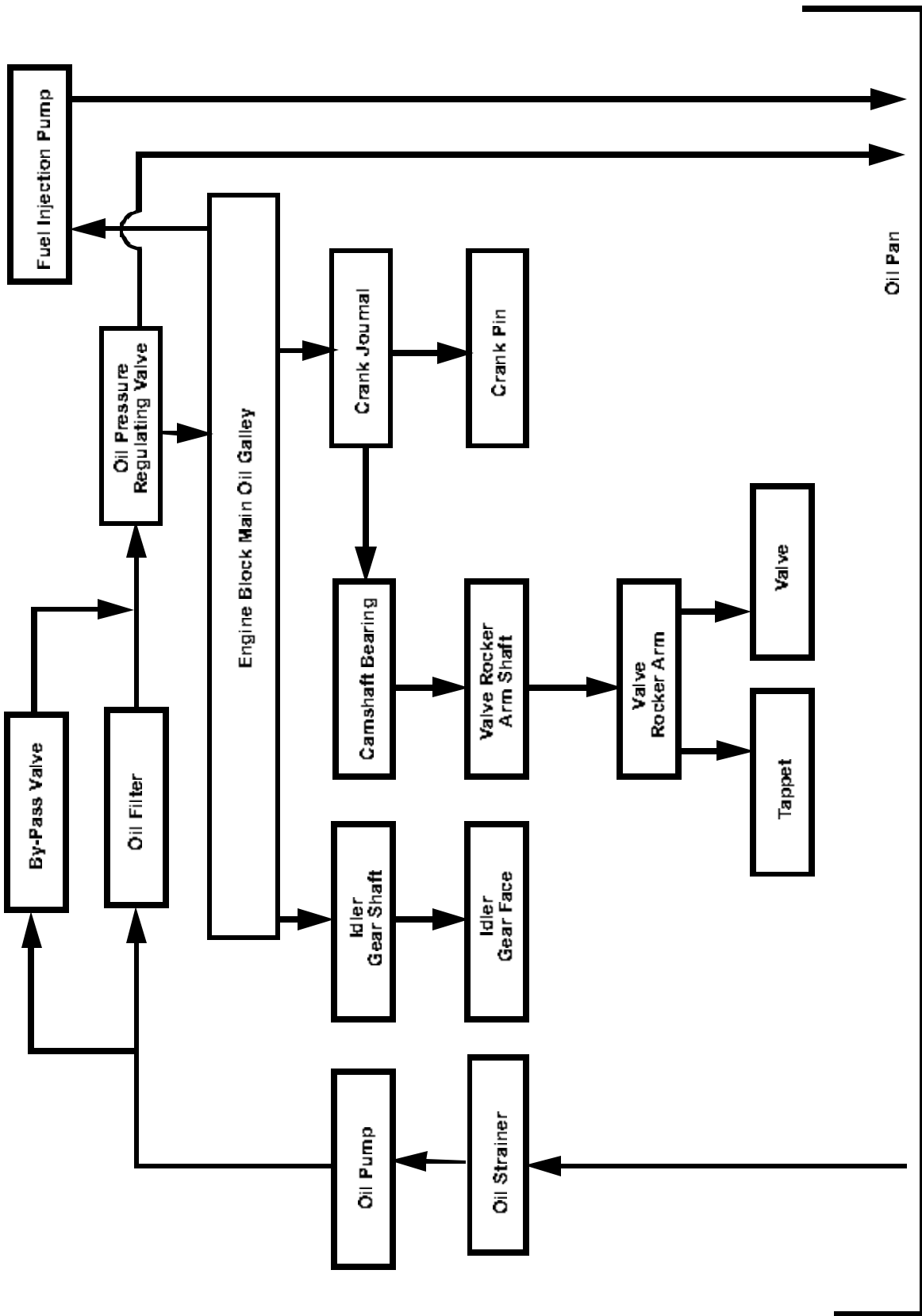

FUEL AND AIR SYSTEM OPERATION

Function:

Fuel system supplies fuel to injection nozzles.
The air intake system filters air needed for combustion.

Theory of Operation:



Fuel System:

An electric fuel transfer pump provides pressurized fuel to the injection pump. The fuel pump draws fuel from a vented fuel tank through an in-line filter. Low pressure fuel from the fuel pump flows through the fuel filter to the fuel gallery of an injection pump. After the injection pump gallery is full, excess fuel is returned, along with fuel from the injectors, through the return line to the fuel tank.

If the unit ever runs out of fuel, there are two air bleed lines that allow air to escape from the top of the filter and the injection pump. These two lines allow the system to be self bleeding.

The engine speed is controlled by the throttle lever and cable. The cable is connected to the injection pump governor control lever. The fuel shutoff solenoid controls the injection pump shutoff shaft. When the solenoid is retracted (key ON), the engine can be started. When the key is turned off, return springs on the shutoff shaft, extend the solenoid, moving the shutoff linkage to the shutoff position.

The injection pump meters fuel as determined by the governor and delivers it at high pressure to the injection nozzles.

The injection nozzle prevents flow until high pressure is reached, opening the valve and spraying atomized fuel into the combustion chamber. Injection lines have trapped fuel whenever injection is not taking place.

A small amount of fuel leaks past the nozzle valve to lubricate the fuel injection nozzle. This leakage combines with excess fuel from the injection pump and is returned to tank. Any air in the fuel system is bled out with return fuel to the fuel tank.

A fuel level sensor mounted in the fuel tank informs the operator of the fuel level.

Air System:

Air enters the air filter through the perforated side holes. The primary and secondary elements filter the air before entering the intake manifold.

An air filter restriction switch informs the operator when the air filter needs servicing. The air filter restriction switch closes when the vacuum reaches a specified level and lights a lamp. A small amount of vacuum is always present due to some restriction of air movement through the filter elements. The unloading valve is like a one way valve. It ejects heavy dirt particles from the air stream during engine operation, but does not let air into the air filter housing. The operator can squeeze the valve to let the large particles out.

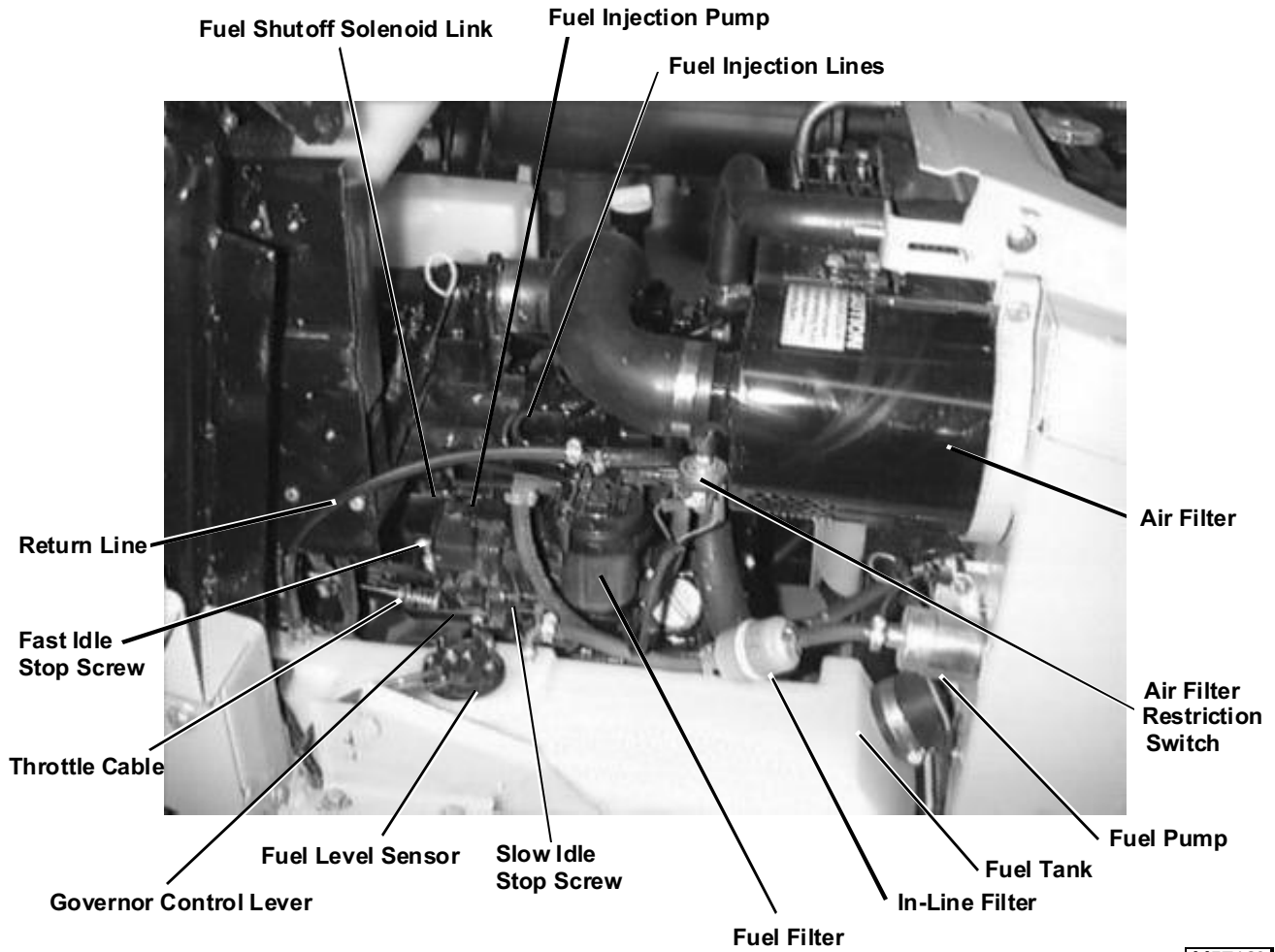

M57120

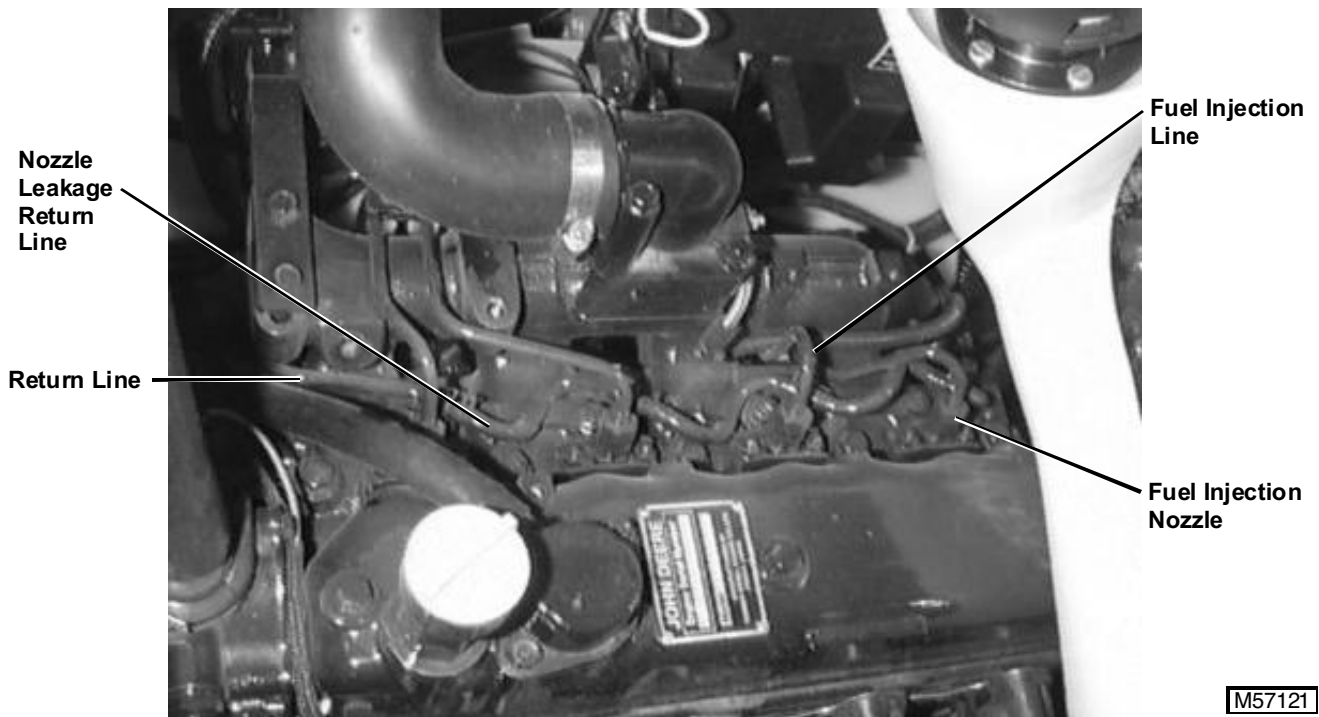



M57121

TROUBLESHOOTING



<div style="display: flex; justify-content: space-between;"> <div style="text-align: center;"> <p>Problem or Symptom</p> </div> <div style="text-align: center;"> <p>Check or Solution</p> </div> </div>	Engine will not start	Engine starts but does not continue to run	Low engine output	Exhaust smoke white when under load	Exhaust smoke black when under load	Engine surges at idle	Engine surges under load	High fuel consumption	High oil consumption	Coolant in oil/oil in coolant	Fuel in oil	Low oil pressure	Air intake pressure drop	Air intake pressure rise
Improper intake/exhaust valve clearance	●	●	●											●
Intake/exhaust valve leaking			●		●			●						●
Intake/exhaust valve seized	●	●	●		●		●				●			
Cylinder head gasket leaking			●							●				
Broken or seized piston ring	●	●		●		●			●		●			●
Piston ring, piston or cylinder worn	●	●		●					●		●			
Crankshaft pin or bearing seized	●	●				●	●							
Ring gaps not positioned properly		●	●						●					
Improper piston ring placement			●	●					●					
Crankshaft pin or bearing worn						●	●					●		
Connecting rod bolt loose												●		
Foreign matter trapped in combustion chamber	●								●					
Excessive timing gear backlash						●	●							
Intake/exhaust valve guide worn			●						●					
Governor not functioning properly		●				●	●							
Improper injection timing, intake/exhaust valves	●		●	●	●									
Engine running too cool				●				●						
Engine running too hot			●											
Coolant level low			●											
Cracked water jacket										●				
Fan belt loose			●											
Malfunctioning thermostat			●											

<div style="text-align: center;"> Problem or Symptom  </div> <div style="text-align: center;">  Check or Solution </div>	Engine will not start	Engine starts but does not continue to run	Low engine output	Exhaust smoke white when under load	Exhaust smoke black when under load	Engine surges at idle	Engine surges under load	High fuel consumption	High oil consumption	Coolant in oil/oil in coolant	Fuel in oil	Low oil pressure	Air intake pressure drop	Air intake pressure rise
Improper engine oil viscosity/type	●	●	●						●			●		
Engine oil leaking									●			●		
Oil pump worn												●		
Oil filter clogged												●		
Pressure control valve worn												●		
Oil quantity low												●		
Advanced injection pump timing				●	●									
Retarded injection pump timing			●	●	●			●						
Wrong type of fuel			●	●	●									
Water in fuel	●	●	●	●		●	●							
Fuel filter clogged	●	●	●											
Air entering fuel system	●	●	●											
Clogged or cracked fuel line	●	●	●											
No fuel	●	●												
Injection pump volume insufficient			●	●	●	●	●							
Injection pump volume excessive					●			●						●
Incorrect spray pattern at fuel injection nozzle			●	●	●	●	●	●						
Air filter clogged		●	●		●								●	
High altitude/temperature operation			●		●			●					●	
Exhaust system restricted			●		●									●
Defective starter motor	●													
Defective alternator	●													
Electrical System Troubleshooting	●													



ENGINE SYSTEM DIAGNOSIS

Conditions:

- Machine parked on level surface.
- Park brake engaged.
- Key switch off unless indicated otherwise.



Test Location

Normal

If Not Normal

1. Engine dipstick and exterior engine surface-engine oil check.

Oil level between “L” and “H” marks. Oil not burnt, or contaminated with metal particles, fuel, or coolant. No external leakage, filter clean.

Change oil and inspect for source of contamination. Check gaskets, seals, plugs, cylinder head, block, and intake manifold and breather. Change oil filter.

2. Coolant tank and radiator.

Coolant level between marks on tank when engine is warm.
Coolant in radiator full to top.
Coolant not contaminated with oil, fuel or discolored brown.
Radiator screen free of debris.
Water pump not leaking.

Add proper coolant mix.

—Cooling System Check

Hoses not cracked or leaking, clamps and radiator cap tight.

Drain and flush system. Check for source of contamination.

Fan belt tight, not glazed or cracked.

Clean or replace.

Inspect water pump. (See “Inspection” on page 109 in this section.)

Pressure test radiator and cap. (See “COOLING SYSTEM PRESSURE TEST” on page 61 in this section.)

Replace and adjust belt tension. (See “FAN/ALTERNATOR DRIVE BELT ADJUSTMENT” on page 60 in this section.)

Fan blades not damaged or warped.

Replace fan.

3. Fuel tank, pump, lines, filter, filter shutoff valve.

Fuel level correct, not contaminated, correct grade of fuel, no water.
Fuel pump in-line filter free of debris.
Fuel shutoff valve in “ON” position.

Drain and clean fuel tank. Add fresh fuel. Replace filters.

—Fuel System Check

Fuel hoses not cracked or leaking.

Move to “ON” position.

Fuel hose clamps tight.

Replace.

Replace or tighten.

4. Air filter and air intake.

Air filter hose not cracked, clamps tight. Element not plugged. Air filter housing sealed, no dirt tracking inside filter element.

Replace and tighten clamps.

—Air Intake System Check

Replace element or housing.

5. Fuel shutoff solenoid.(Key in RUN position.)

Fuel shutoff solenoid must pull in and stay in. Solenoid must bottom out. Shutoff shaft must still move slightly.

Check shutoff solenoid adjustment. (See “FUEL SHUTOFF SOLENOID ADJUSTMENT” on page 49 in this section.)

Clean any dirt from under solenoid boot. If solenoid will not pull in and hold in, See “Fuel Shutoff Solenoid Circuit Diagnosis” in ELECTRICAL section.

ENGINE SYSTEM DIAGNOSIS - Continued

Test Location	Normal	If Not Normal
6. Preheat indicator light. (Key in RUN position.)	Indicator light should come on up to 45 seconds depending on air temperature.	See "Glow Plug/Manifold Heater Light Circuit Diagnosis" in ELECTRICAL section.
7. Fuel filter, fuel pump. (Key switch in RUN position.)	Fuel level increases in filter. Fuel pump operating - listen for humming sound. Fuel present in return hose at fuel pump.	See "Fuel Pump Power Circuit Diagnosis" in ELECTRICAL section. Test fuel pump pressure. (See "FUEL SUPPLY PUMP PRESSURE TEST" on page 63 in this section.) Replace fuel filter.
8. Throttle lever and cable.	Linkage not binding and adjusted correctly.	Repair, replace or adjust cable. (See "THROTTLE CONTROL ADJUSTMENT" on page 48 in this section.)
9. Intake and exhaust valves.	Cold engine. Valve clearance within specification. Valves not sticking.	Check and adjust. (See "VALVE CLEARANCE CHECK AND ADJUSTMENT" on page 51 in this section.) Check valve guides and stems.
10. Fuel at injectors. (Key in START position - engine cranking.)	Crack fuel injection lines at injectors. Fuel shutoff solenoid pulled in. Engine must crank.	Check spray pattern and cranking pressure. (See "FUEL INJECTION NOZZLE TEST (HOLE-TYPE)" on page 56 in this section.) Replace injectors. See "Cranking Circuit Diagnosis" in ELECTRICAL section.
11. Injector ports. (Key in START position.)	Cylinder compression within specification. Pressure difference between cylinders within specification.	Perform cylinder compression test. (See "CYLINDER COMPRESSION PRESSURE TEST" on page 48 in this section.)
12. Flywheel and starter.	Minimum cranking rpm within specification.	See "Starter Amp Draw Test" in ELECTRICAL section.
13. Injection pump timing inspection. (Key OFF.)	Timing should be correct. Remove pump as the LAST possible solution.	Perform injection pump static timing adjustment. (See "INJECTION PUMP STATIC TIMING ADJUSTMENT" on page 59 in this section.) Have pump tested by a qualified Service Repair Shop.
14. Injection pump idle settings. (Engine running).	Engine runs smooth under load. Engine rpm to specification.	See "SLOW IDLE ADJUSTMENT" on page 49 and "FAST IDLE ADJUSTMENT" on page 50 in this section.
15. Oil pressure sender port.	Oil pressure in specification.	Test engine oil pressure. (See "ENGINE OIL PRESSURE TEST" on page 62 in this section.)
16. Thermostat. (Engine at operating temperature.)	Clean from corrosion, rust, or debris. Opening temperature within specification.	Replace thermostat. Perform thermostat opening test. (See "THERMOSTAT OPENING TEST" on page 58 in this section.)
17. Muffler.	Not restricted.	Replace muffler.







CHECKS, TESTS AND ADJUSTMENTS

CYLINDER COMPRESSION PRESSURE TEST

Reason:

To determine the condition of the pistons, rings, cylinder walls and valves.



Equipment:

- JT01682 Compression Gauge Assembly
- JDG560 Adapter

Procedure:

1. Remove injection nozzles.

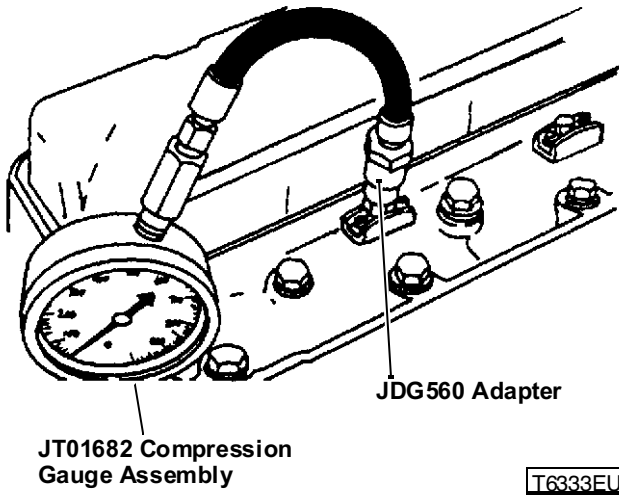

2. Install heat protector from end of injector and install on JDG560 adapter.
3. Install JT01682 Compression Gauge Assembly and JDG560 Adapter.
4. Disconnect fuel control solenoid connector.

IMPORTANT: DO NOT overheat starter motor during test.

5. Crank engine for five seconds with starter.
6. Record pressure reading for each cylinder.

Specifications:

Minimum Compression 2448 kPa (355 psi)
Maximum difference between cylinders 490 kPa (71 psi)
Minimum cranking speed 250 rpm

Results:

- If pressure reading is below specification, squirt clean engine oil into cylinders through injector ports and repeat test.
- If pressure increases significantly, check piston, rings, and cylinder walls for wear or damage.
- If pressure does not increase significantly after retest, check for leaking valves, valve seats or cylinder head gasket.

THROTTLE CONTROL ADJUSTMENT

Reason:

To achieve smooth throttle lever movement with enough tension to maintain throttle setting and to insure that the throttle control moves governor lever fully from idle to fast idle position.

Procedure:

1. Connect a spring scale near the end of the throttle lever.



2. Adjust friction by tightening or loosening lock nut until throttle lever movement in forward direction requires **35—53 N (8—12 lb force)**.

NOTE: Make sure throttle cable is not binding or stuck.

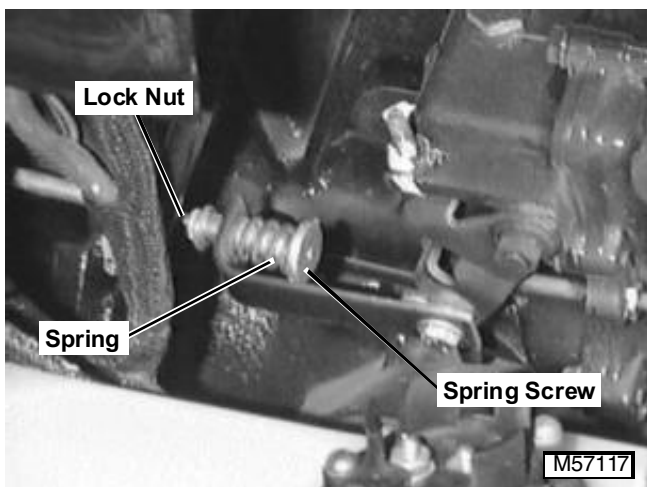

3. Move the throttle lever to the slow idle position. The control rod spring should not be compressed.
4. Move the throttle lever to the fast idle position. The spring should be compressed to 19 mm (0.75 in.).
5. If the spring length is not correct, loosen lock nut and adjust the spring screw. Tighten lock nut.

FUEL SHUTOFF SOLENOID ADJUSTMENT

Reason:

To ensure that fuel shutoff solenoid retracts fully, moving the injection pump shutoff control lever far enough to allow full rack travel.

Procedure:

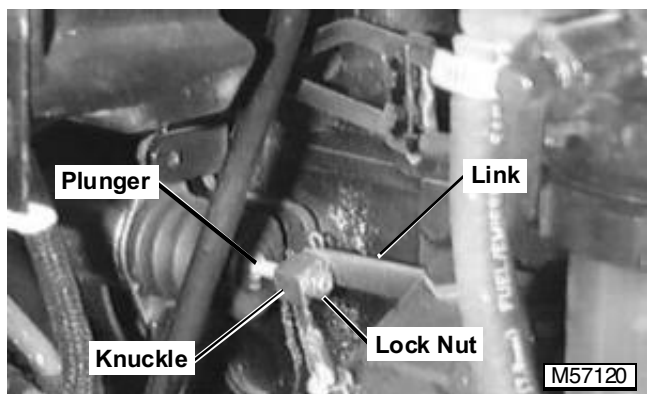

1. Loosen lock nut.
2. Disconnect link from solenoid.
3. Hold solenoid plunger bottomed in solenoid body.
4. Move link toward solenoid until it stops.
5. Turn plunger rod in or out of knuckle until knuckle and link holes line up. Turn out two additional turns.

NOTE: The additional turns insure that the solenoid bottoms out before the linkage.

6. Assemble and start engine. Check for free movement of the linkage while engine is running. Also check that linkage returns completely to the STOP position when key switch is turned OFF.

SLOW IDLE ADJUSTMENT

Reason:

To achieve proper slow idle rpm setting. Provides adequate rpm to keep engine running smoothly without stalling.



Equipment:

- JT05719 Hand Held Digital Tachometer

Procedure:

1. Start engine and run for 5 minutes to attain operating temperature.
2. Move throttle lever to slow idle position.
3. Place a small piece of reflective tape on crankshaft pulley.
4. Use JT05719 Hand Held Digital Tachometer to check engine speed at crankshaft pulley.
5. Visually check that injection pump throttle lever is against slow idle stop screw. Check slow idle speed.

Specifications:

Slow Idle Speed 950 ± 50 rpm

Results:

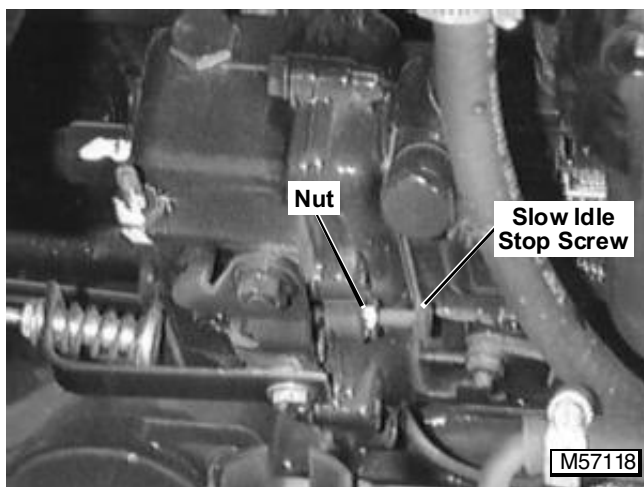

- If slow idle rpm is not according to specifications, loosen nut and turn slow idle stop screw. After adjustment, tighten nut.

FAST IDLE ADJUSTMENT

Reason:

To achieve proper fast idle speed setting. This insures that engine is running at proper rpm's for peak performance.

Equipment:

- JT05719 Hand Held Digital Tachometer



Procedure:

1. Start engine and run for 5 minutes to attain operating temperature.
2. Move throttle lever to fast idle position.
3. Place a small piece of reflective tape on crankshaft pulley.
4. Use JT05719 Hand Held Digital Tachometer to check engine speed at crankshaft pulley.
5. Visually check injection pump throttle lever is up against fast idle stop screw. Check fast idle speed.

Specifications:

Fast Idle Speed..... 3150 ± 25 rpm

Results:

NOTE: Some adjustment can be made without removing sealed wire. Attempt to make the adjustment before removing wire.

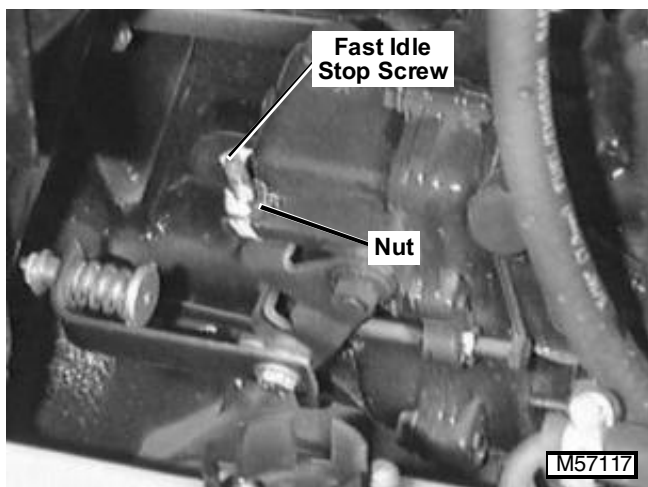

- If fast idle rpm is not according to specifications, loosen nut. Turn fast idle stop screw until fast idle speed is correct. After adjustment, tighten nut.

NOTE: Make sure air cleaner is clean and not restricted. Replace air cleaner element as necessary.

- If engine still does not meet fast idle speed specifications, have pump inspected by an diesel injection service.

INJECTION PUMP TIMING ADJUSTMENT

Reason:

To make sure that injection pump timing is set to manufactures specifications.

Procedure:

IMPORTANT: Injection pump timing should be correct. Once timing is set, it will not normally change during the life of the engine, unless it was altered. Check and adjust timing only as the last option. Check fuel, fuel supply system, injectors, air intake system and cylinder compression before continuing.

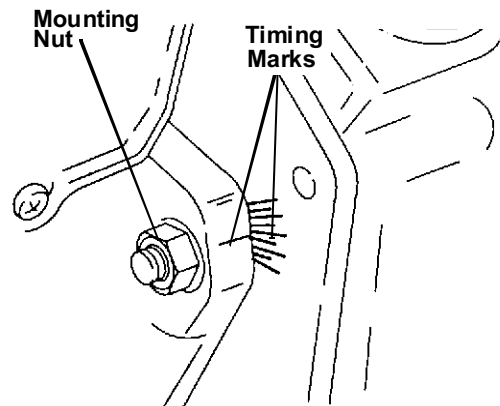

M57132

1. Clean around injection pump area.
2. Injection pump timing is set by aligning the arrow between the **5th and 6th** line from the top.
3. Loosen injection pump mount nuts and rotate to align marks.
4. Tight injection pump mount nuts to 27 N•m (20 lb-ft).

Results:

- If engine performance is poor, check air cleaners, fuel filter, fuel supply, injectors and cylinder compression before attempting to adjust timing. Then reset injection pump timing by aligning marks. Retest performance.
- If performance did not change, have pump tested by a diesel injection service.



Suggest:

If the above button click is invalid.

Please download this document

first, and then click the above link

to download the complete manual.

Thank you so much for reading

VALVE CLEARANCE CHECK AND ADJUSTMENT

Reason:

To achieve correct engine operation.

Equipment:

- Feeler Gauge

Procedure:

1. Remove rocker arm cover.
2. Remove plug from timing hole in flywheel housing at 9 O'clock position (viewed from rear), if equipped.

NOTE: "Top Dead Center (TDC)" is the piston at its highest point.

3. Turn crankshaft pulley clockwise until No.1 cylinder TDC mark on flywheel aligns with index mark on flywheel housing or plate.

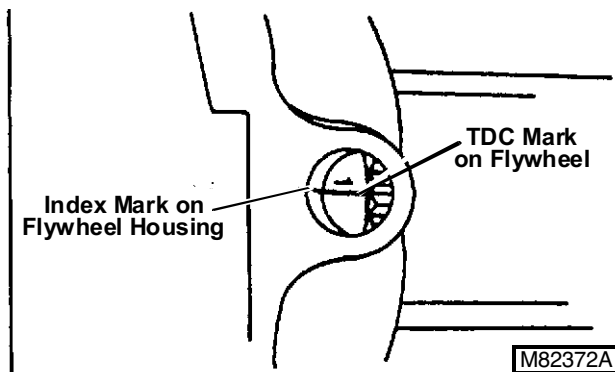

NOTE: No. 1 cylinder is the closest to the flywheel.

4. Try to move both No. 1 cylinder rocker arms or push rods.

NOTE: If rocker arm push rods are not loose, rotate flywheel one revolution (360°). If both rocker arm push rods are loose the piston is at TDC on compression stroke.

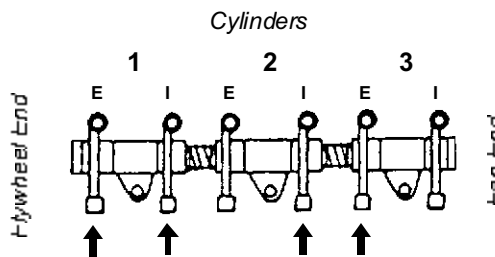

No. 1 Piston at TDC

3015D001 (3TNE84)
3017D001 (3TNE88)

M82327A

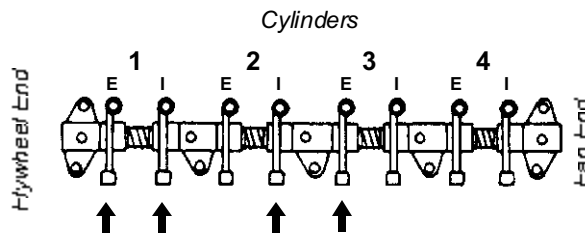

No. 1 Piston at TDC

4020D001 (4TNE84)
4022D001 (4TNE88)

T6479AB

5. Measure and adjust valve clearance on the valves (arrows) with No. 1 piston at TDC.

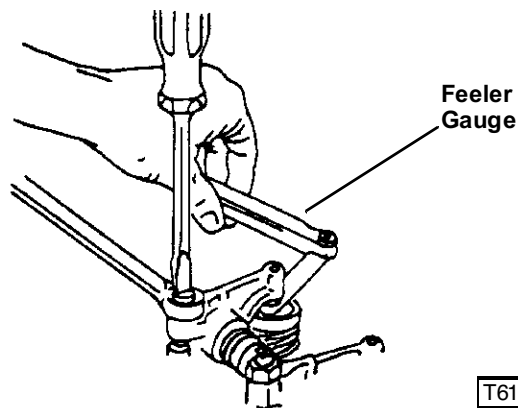

6. To adjust valves, loosen nut and turn adjusting screw until clearance is **0.20 mm (0.008 in.)**. Hold screw while tightening nut.

7. Turn crankshaft pulley one revolution (360°). This puts the piston in No. 2 cylinder for 3015D001 (3TNE84) and 3017D001 (3TNE88) engines or No. 4 cylinder for 4020D001 (4TNE84) and 4022D001 (4TNE88) engines at TDC compression stroke.

<https://www.ebooklibonline.com>

Hello dear friend!

Thank you very much for reading.

Enter the link into your browser.

The full manual is available for immediate download.

<https://www.ebooklibonline.com>