

tm4523 - 6200, 6200L, 6300, 6300L, 6400, 6400L, 6500, 6500L Tractors Assembling the Creeper Transmission

Assembling the Creeper Transmission

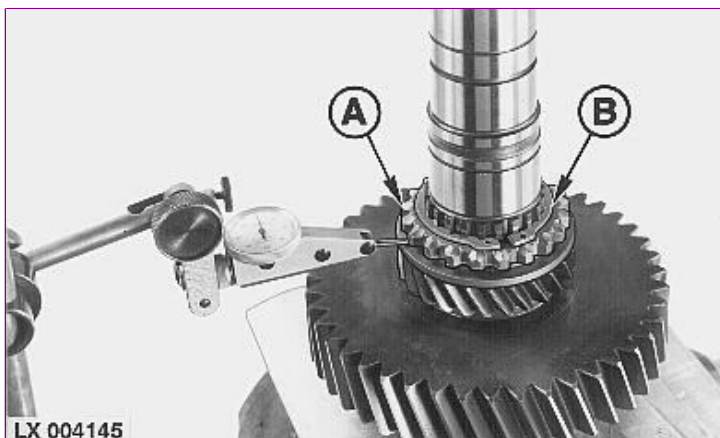

LX004145-UN: Creeper Transmission

Install connecting ring (A) on drive shaft.

Install snap ring (B).

NOTE:

Connecting ring axial play must be less than 0.1 mm (0.004 in.).

Item	Measurement	Specification
Connecting ring	Axial play	less than 0.1 mm (0.004 in.)

-: Snap Ring Thickness

Thickness of snap rings available

1.45 mm (0.057 in.) 1.65 mm (0.065 in.)

1.55 mm (0.061 in.) 1.75 mm (0.069 in.)

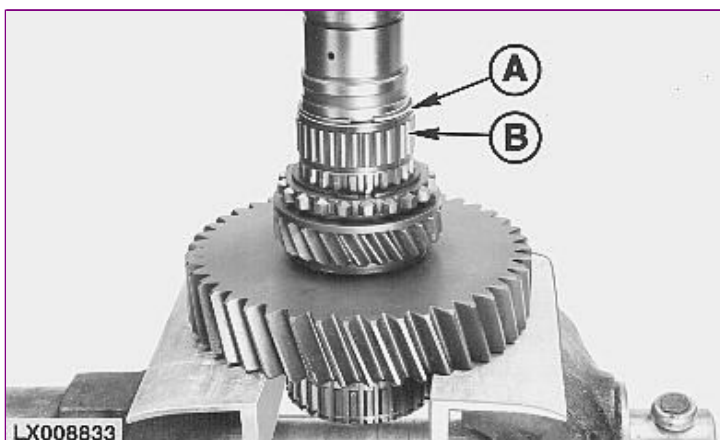

LX008833-UN: Needle Bearing & Thrust Washers

Install needle bearing (B) with thrust washers.

Install snap ring (A).



LX000220

LX000220-UN: Gears

Position gear (B) on gear (C).

Install thrust washer (A) and snap ring.

Older tractor series:

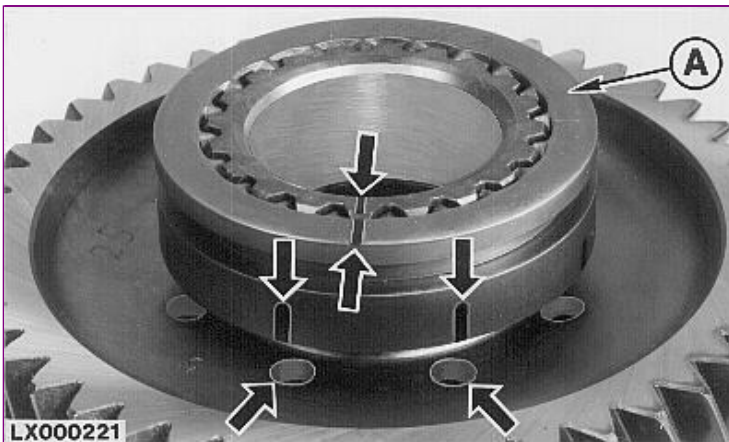

LX000221

LX000221-UN: Shift Collar



LX000222

LX000222-UN: Install Shift Collar W/Pins

Install shift collar (A).

Before installing shift collar, mark position of bores and splines (see arrows).

Grease pins and install on shift collar.

Install shift collar with pins.

Latest tractor series:

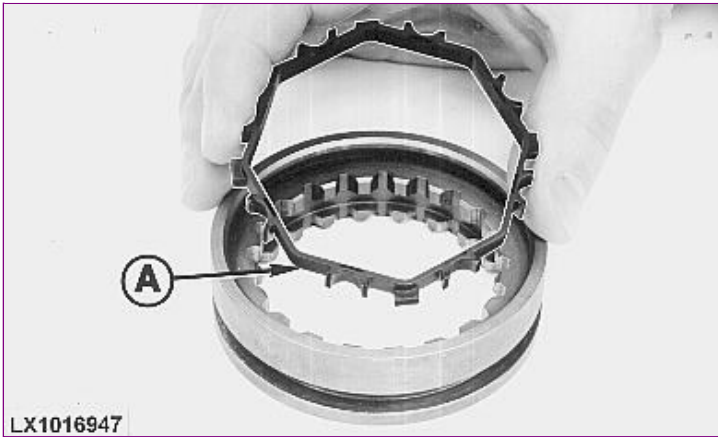

LX1016947

LX1016947-UN: Retaining Ring

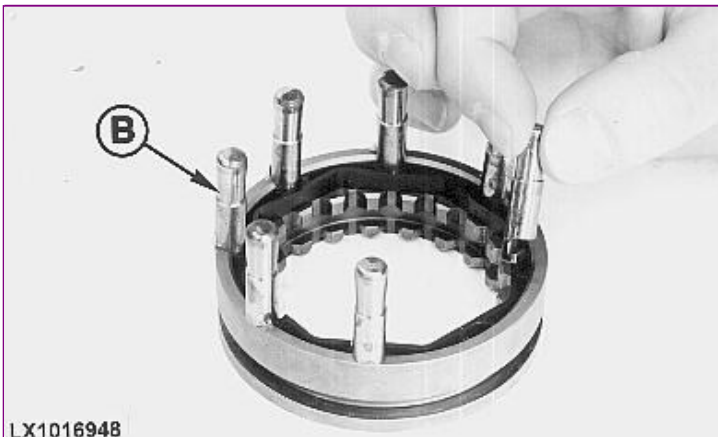

LX1016948

LX1016948-UN: Pin Installation

Install retaining ring (A) on the shift collar.

Install pins (B).

Install the shift collar and pins.

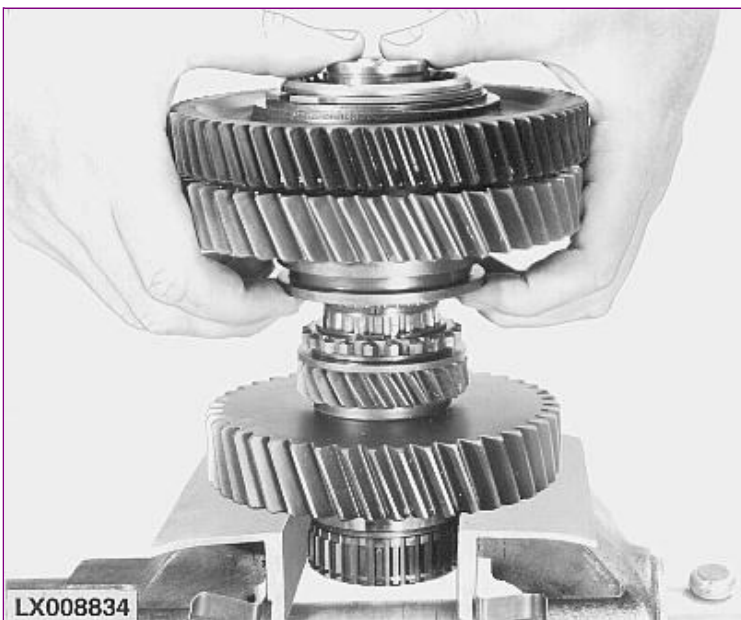

LX008834

LX008834-UN: Drive Shaft Gears

Install gears on drive shaft.

NOTE:

<https://www.ebooklibonline.com>

Hello dear friend!

Thank you very much for reading.

Enter the link into your browser.

The full manual is available for immediate download.

<https://www.ebooklibonline.com>

When installing gears, press shift collar against gears. This prevents the shift collar and pins from falling out.

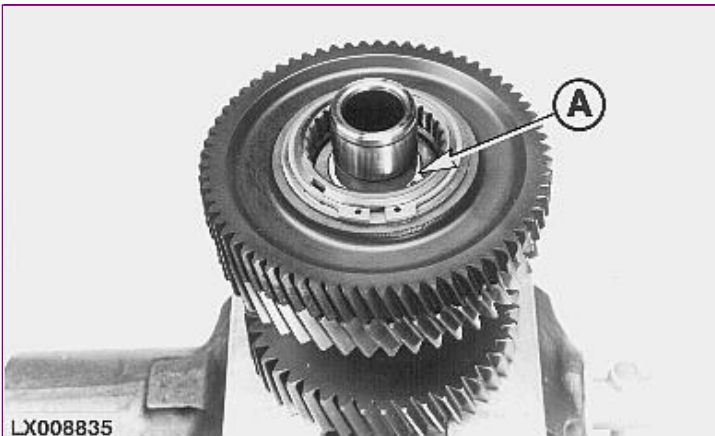

LX008835
LX008835-UN: Snap Ring Installation

Install the two axial bearings. Install snap ring (A).

Install lower snap ring of needle bearing.

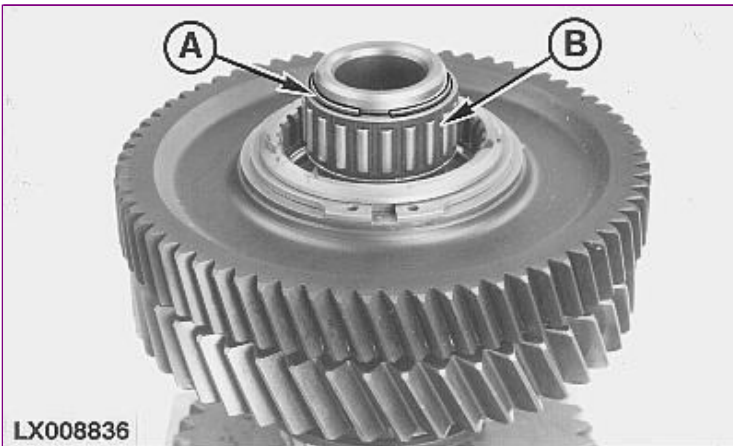

LX008836
LX008836-UN: Needle Bearing With Thrust Washers

Install needle bearing (B) with thrust washers.

Install upper snap ring (A).



LX008831
LX008831-UN: Drive Shaft & Double Gear Ball Bearings

Install ball bearing (B) of drive shaft and ball bearing (A) of double gear.

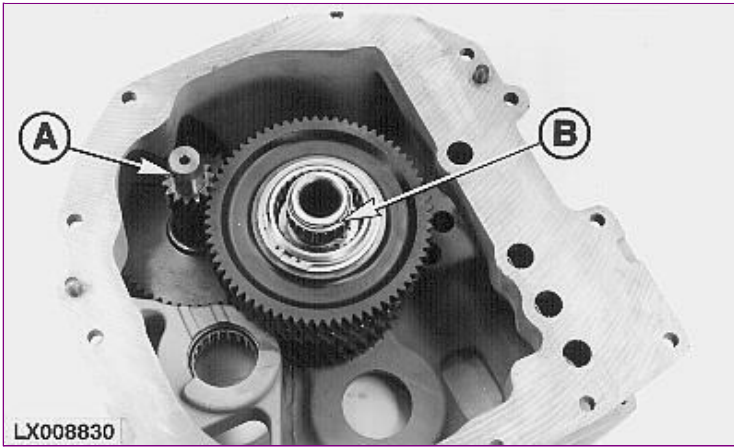

LX008830
LX008830-UN: Drive Shaft & Double Gear

Install drive shaft (B) and double gear (A).

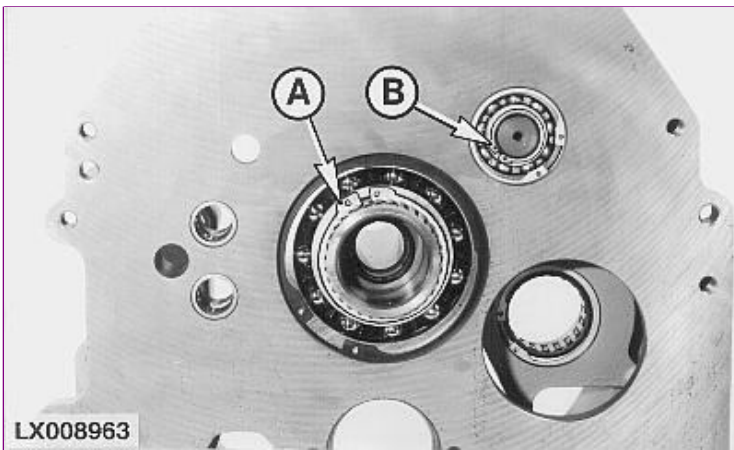

LX008963
LX008963-UN: Snap Rings

Install snap rings (A) and (B).

tm4523 - 6200, 6200L, 6300, 6300L, 6400, 6400L, 6500, 6500L Tractors
Sectional View of Shift Linkage

Sectional View of Shift Linkage

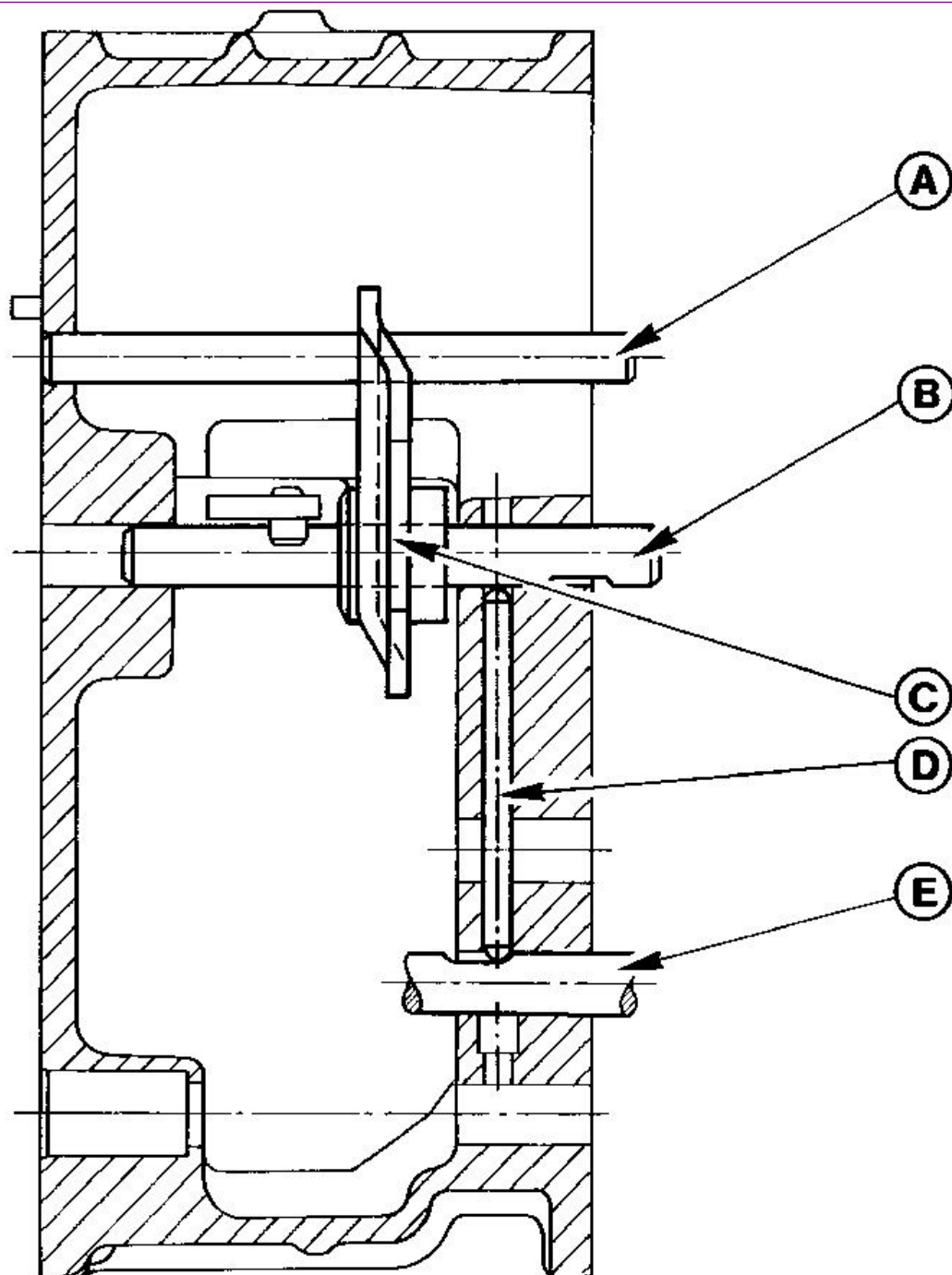

LX008837

LX008837-UN: Shift Linkage-Sectional View

LEGEND:

- A - Shaft
- B - Shifter shaft
- C - Shifter fork
- D - Locking pin
- E - Shifter shaft ranges C and D

Installation instructions

NOTE:

Shifter shaft (E) is a component of the range transmission and protrudes into the creeper transmission once the latter is installed.

If necessary, install locking pin (D).

Locking pin (D) must be raised when the creeper transmission is installed so that the housing can be pushed over shifter shaft (F).

tm4523 - 6200, 6200L, 6300, 6300L, 6400, 6400L, 6500, 6500L Tractors Installing the Shift Linkage

Installing the Shift Linkage

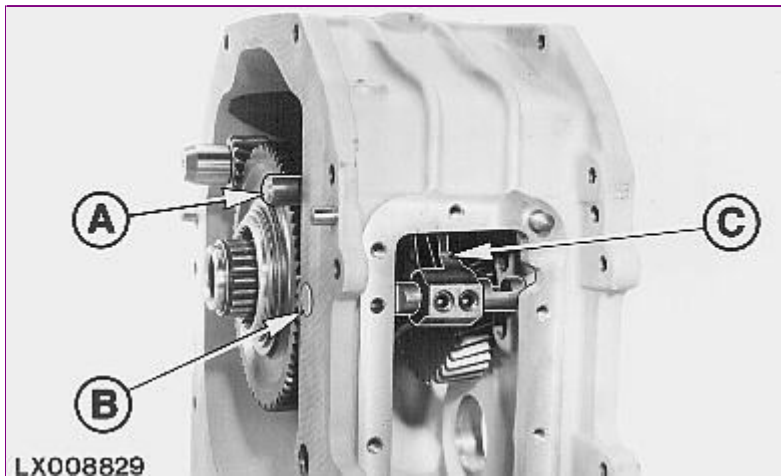

LX008829
LX008829-UN: Shift Linkage-Installation

Install shifter shaft (B) with shifter fork (C).

Install shaft (A).

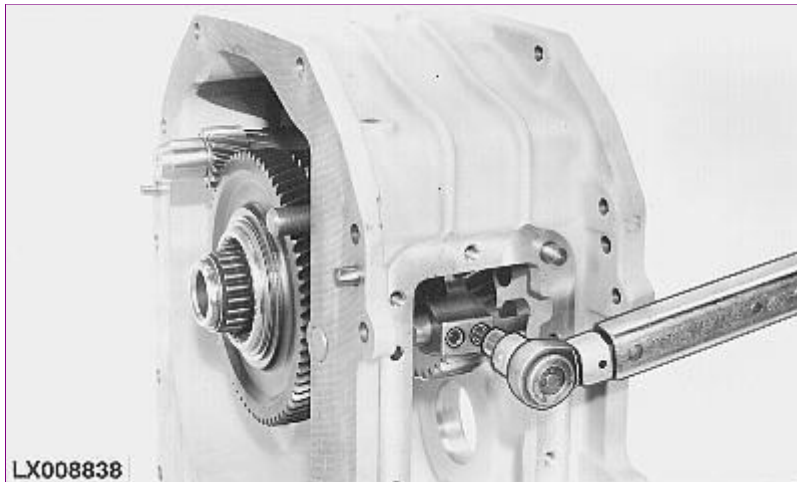

LX008838
LX008838-UN: Threaded Pins

Tighten threaded pins to 40 N·m (30 lb-ft).

Item	Measurement	Specification
Threaded Pins of Shifter Fork	Torque	40 N·m (30 lb-ft)

tm4523 - 6200, 6200L, 6300, 6300L, 6400, 6400L, 6500, 6500L Tractors Repairing the Shift Cover

Repairing the Shift Cover

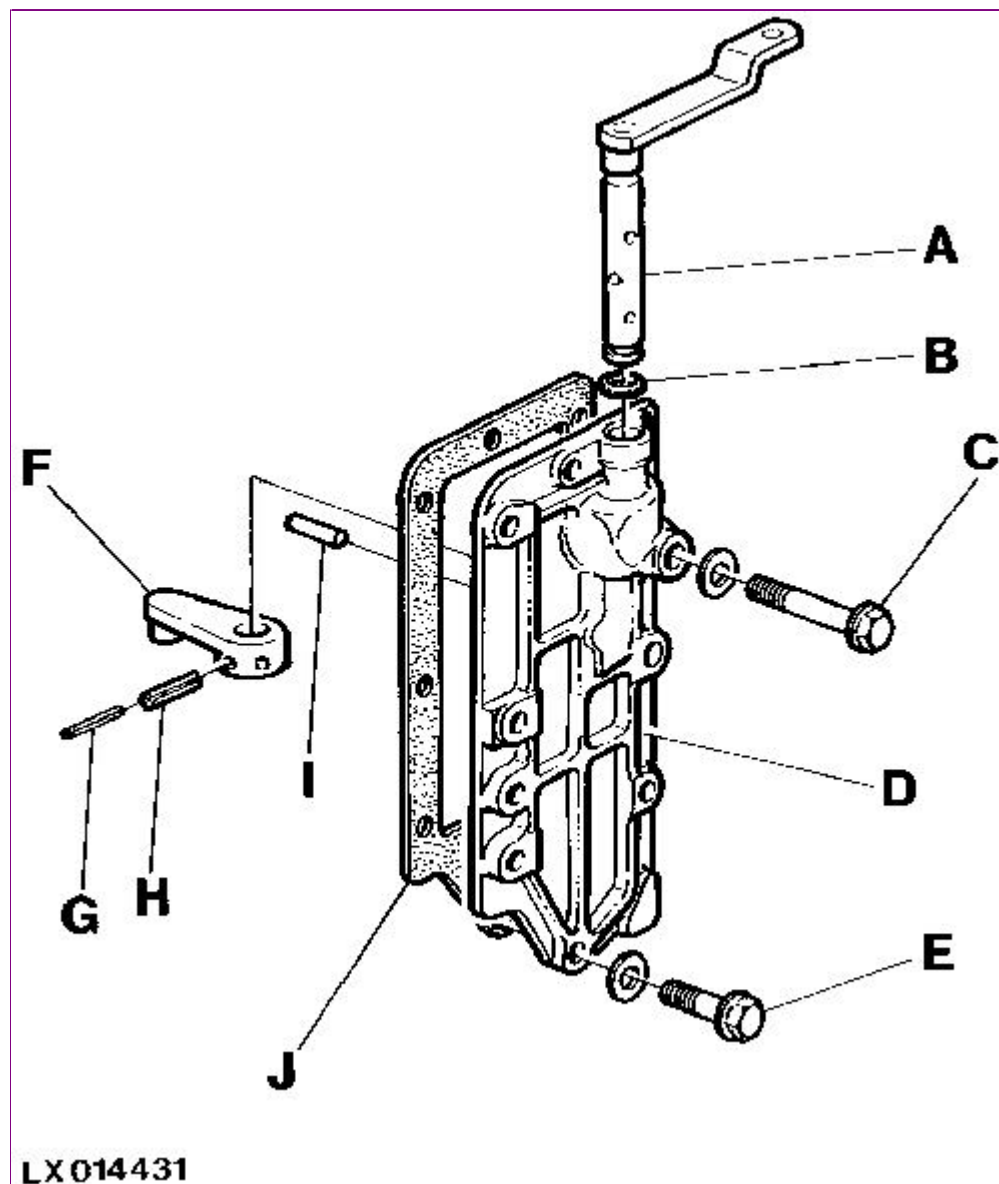

LX014431

LX014431-UN: Repairing the Shift Cover

LEGEND:

- A - Shaft
- B - O-ring
- C - Cap screw
- D - Shift cover
- E - Cap screw (7 used)
- F - Lever
- G - Spring pin (dia. 5 mm; 13/64 in.)
- H - Spring pin (dia. 8 mm; 5/16 in.)
- I - Dowel pin
- J - Gasket

NOTE:

Use an M6 screw to extract dowel pin (I).

Drive spring pins (G) into spring pins (H). They must be offset by 180 degrees.

NOTE:

Up to transm. serial no. 115624, lever (F) has only one 6 mm (15/64 in.) dia. spring pin. If necessary, replace this spring pin with spring pins (G) and (H). This also requires the replacement of shifter shaft (A) and lever (F).

tm4523 - 6200, 6200L, 6300, 6300L, 6400, 6400L, 6500, 6500L Tractors Final Assembly

Final Assembly

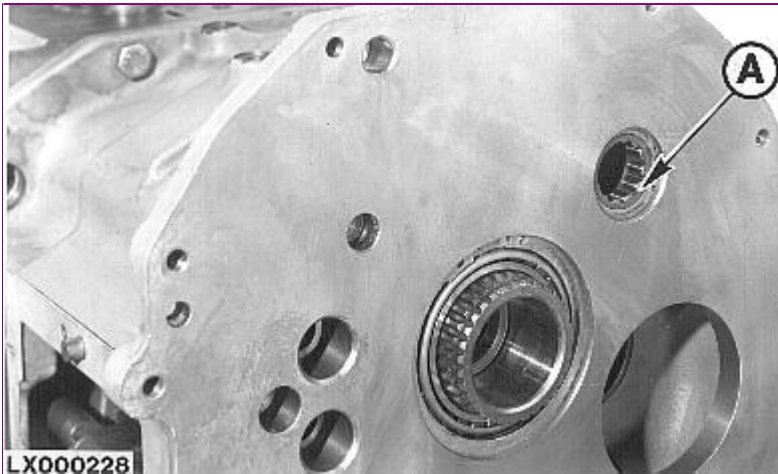

LX000228-UN: Needle Bearing

Install needle bearing (A) of double gear into the range transmission.

NOTE:

When installing the creeper transmission, raise the long locking pin (see “Sectional View of Shift Linkage”) so that the housing can be pushed over the shifter shaft that protrudes out of the range transmission.

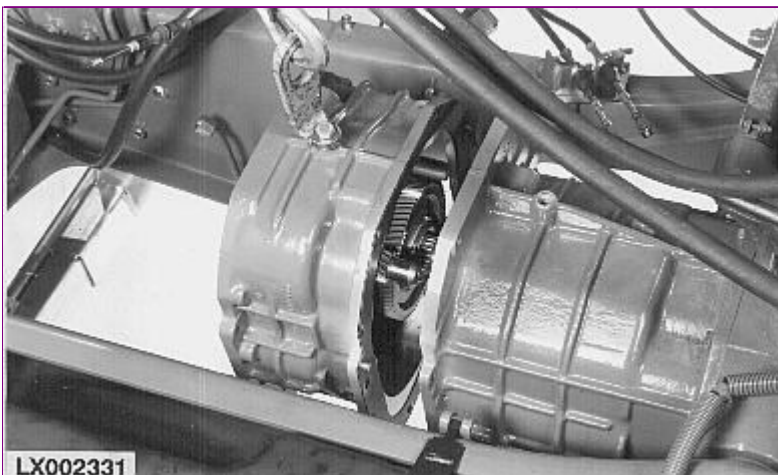

LX002331-UN: Transmission Housing

Install the transmission housing. [See Group 00](#) .

SyncroPlus transmission: Install the gear transmission and PERMA-CLUTCH 2™ . [See Group 00](#) .

PowrQuad transmission: Install the PowrQuad® module. [See Section 55, Group 00](#) .

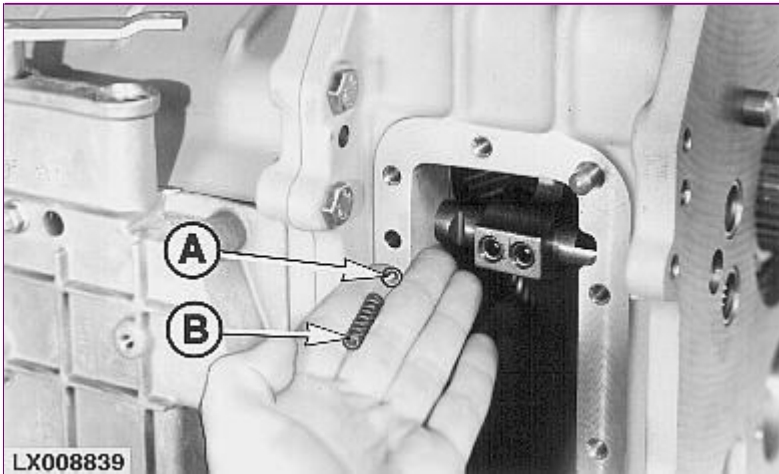

LX008839-UN: Shifter Shaft Lock

LEGEND:

- A - Ball
- B - Spring

Install shifter shaft lock.



LX008840-UN: Shift Cover

Install shift cover.

Tighten cap screws to 30 N·m (22 lb-ft).

Item

Measurement

Specification

Shift Cover to Transmission
Housing, Cap Screws

Torque

30 N·m (22 lb-ft)

PERMA-CLUTCH 2 is a trademark of Deere & Company.
PowrQuad is a trademark of Deere & Company.

LX,RDTH002001-19-1996/04/01

tm4523 - 6200, 6200L, 6300, 6300L, 6400, 6400L, 6500, 6500L Tractors Specifications

Specifications

Item	Measurement	Specification
Main shaft	Axial play	less than 0.1 mm (0.004 in.)
Main shaft and ring gear	Cone point distance	± 0.06 mm (0.0024 in.)
Front wheel drive gear	Axial play	less than 0.1 mm (0.004 in.)
Range gears	Axial play	0.15 to 0.60 mm (0.006 to 0.024 in.)
Synchronizer units	Axial play	less than 0.1 mm (0.004 in.)
Drive shaft	Axial play	less than 0.1 mm (0.004 in.)
Drive shaft bearing quill to differential housing, attaching screws and bolts	Torque	55 N·m (40 lb-ft)
Main shaft bearing quill to differential housing, cap screws	Torque	55 N·m (40 lb-ft)
Parking lock shifter shaft	Clearance	0.25 to 0.60 mm (0.010 to 0.024 in.)
Transmission housing to differential housing, cap screws		
Grade 8.8	Torque	90 N·m (65 lb-ft) 120 N·m (90 lb-ft)
Grade 10.9	Torque	120 N·m (90 lb-ft)
Needle bearings in transmission housing, cap screws	Torque	30 N·m (22 lb-ft)
Threaded pins of shifter forks	Torque	40 N·m (30 lb-ft)
Shift cover to transmission housing, cap screws	Torque	30 N·m (22 lb-ft)
Countersunk screw in differential drive shaft	Torque	25 N·m (18 lb-ft)

-: Adjusting Cone Point pf Diff. Drive Shaft

Adjusting Cone Point pf Diff. Drive Shaft

(Determining Spacer Washer Thickness):

	Example
(a) Dimension stamped on bevel gear face, read.....	172.0 mm (6.772 in.)
(b) Dimension from needle bearing to bearing quill, measured.....	+ 48.1 mm (1.894 in.)
(c) Cone point dimension of differential housing as specified.....	-219.5 mm (8.642 in.)
(d) Required shim thickness.....	= 0.6 mm (0.014 in.)

NOTE:

In most cases the dimension (a) stamped on bevel gear face is exactly 172,0 mm (6.772 in.).

tm4523 - 6200, 6200L, 6300, 6300L, 6400, 6400L, 6500, 6500L Tractors General Repair Procedures- Range Transmission

General Repair Procedures- Range Transmission

NOTE:

Before beginning the repair, review the following guidelines. These are provided to emphasize the need for attention to detail and care when servicing the range transmission.

Thoroughly clean the outside of the housing before commencing disassembly.

Handle parts carefully to prevent nicking or burring machined surfaces.

The repair area should be kept clean, well organized, and supplied with clean lint-free shop cloths.

Inspect before Disassembly

Inspect the range transmission shafts and countershafts before removal. Inspection may make it easier to decide what repairs are required.

Wipe lubricant off the internal components and examine them to determine if there is excessive wear or damage.

Disassembly and Assembly

Many parts and surfaces are precision machined. Careful handling during disassembly, cleaning, inspection and assembly can prevent unnecessary damage.

Lubricate each component part with clean hydraulic oil.

Needle bearings and thrust washers should be lightly coated with petroleum jelly during assembly.

Use new O-rings, seals and gaskets.

Comply with the prescribed specifications (torques, settings).

Cleaning and Inspection

Clean all parts with clean suitable solvent and use moisture-free air to dry parts.

Bearings

Never dry bearings with compressed air. Spinning a bearing without lubrication can damage the bearing.

Clean the bearings with clean solvent, dry thoroughly, and oil before inspection. Inspect bearings for signs of wear or damage.

Inspect thrust washers and thrust surfaces for signs of wear or damage.

Springs

Inspect all springs for wear, damage or distortion.

Shafts

Inspect the shaft bearing surfaces for wear or damage. If excessive wear or damage is detected, replace the shaft and bearings.

Inspect the shafts for wear or damage.

Gears

Inspect the gear teeth for signs of wear or damage.

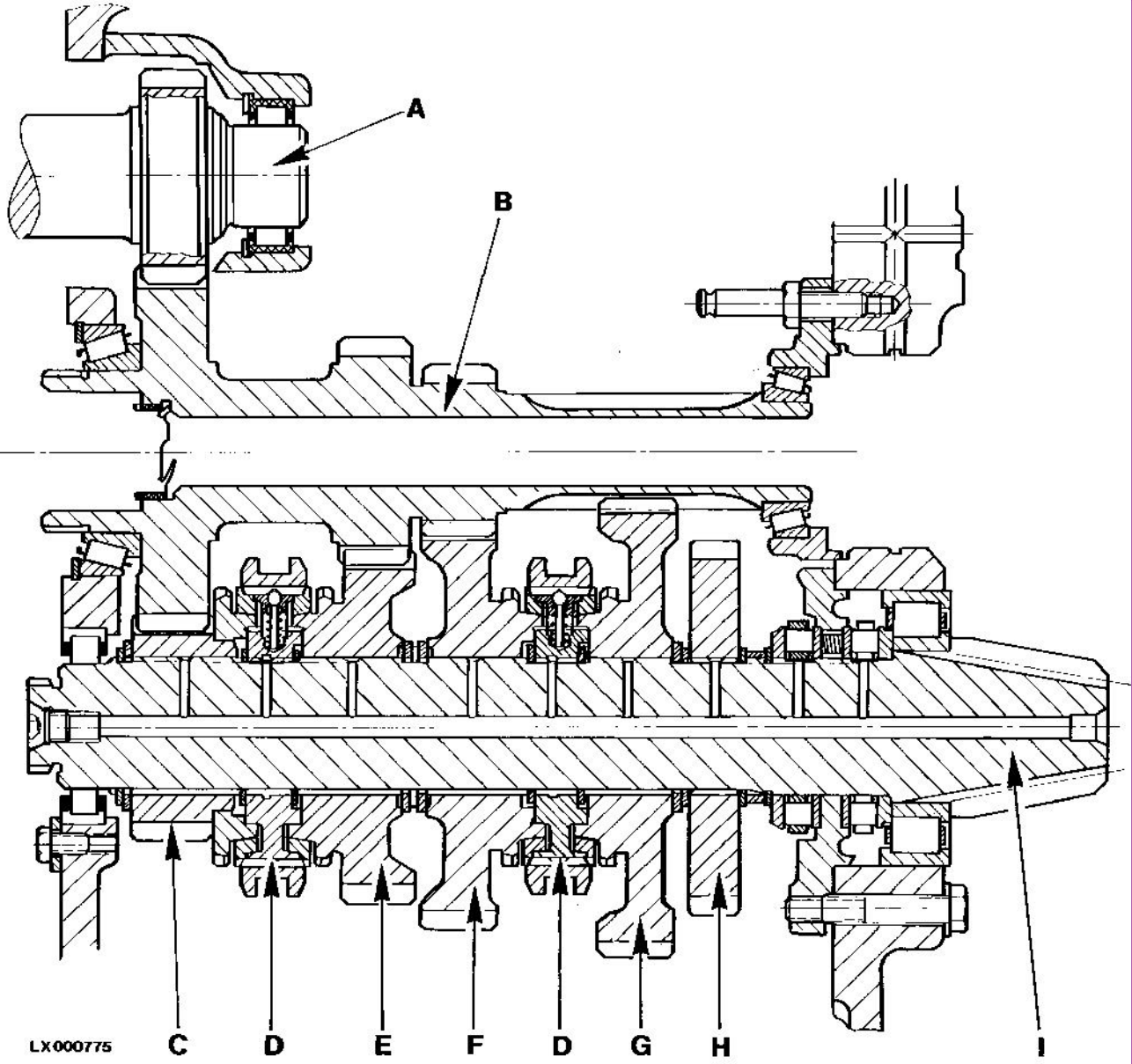

LX000775-UN: Range Transmission

LEGEND:

- A - Countershaft of gear transmission
- B - Drive shaft
- C - Gear of range D
- D - Synchronizer unit
- E - Gear of range C
- F - Gear of range B
- G - Gear of range A
- H - Front wheel drive gear
- I - Differential drive shaft

tm4523 - 6200, 6200L, 6300, 6300L, 6400, 6400L, 6500, 6500L Tractors Preliminary Work

Preliminary Work

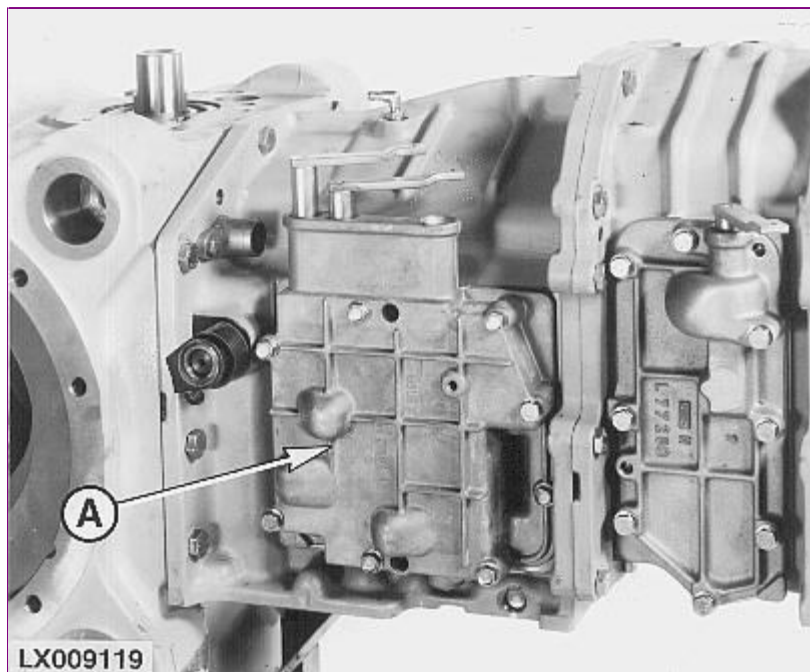

LX009119-UN: Preliminary Work

1. Remove shift cover (A).
2. *SyncroPlus* transmission: Remove hydraulic clutch and gear transmission, [see Group 00](#) .
PowrQuad transmission: Remove PowrQuad® module , [see Group 00](#) .
3. If equipped, remove creeper transmission, [see Group 00](#) .
4. Remove front wheel drive clutch, see Section 56, Group 10.
5. Remove PTO [Only necessary when differential drive shaft is to be removed.] , [see Section 56, Group 00](#) .
6. Remove final drives [Only necessary when differential drive shaft is to be removed.] , [see Section 56, Group 00](#) .
7. Remove differential [Only necessary when differential drive shaft is to be removed.] , [see Section 56, Group 15](#) .

tm4523 - 6200, 6200L, 6300, 6300L, 6400, 6400L, 6500, 6500L Tractors Disassembling Range Transmission

Disassembling Range Transmission

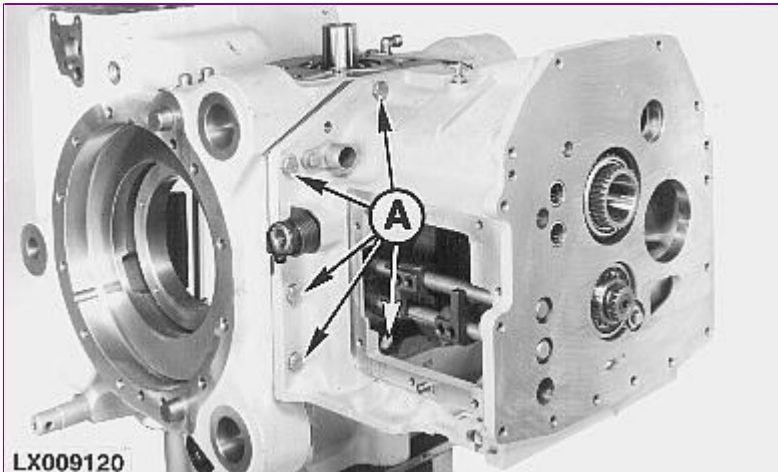

LX009120
LX009120-UN: Disassembling Range Transmission

Remove cap screws (A).

Remove transmission housing.

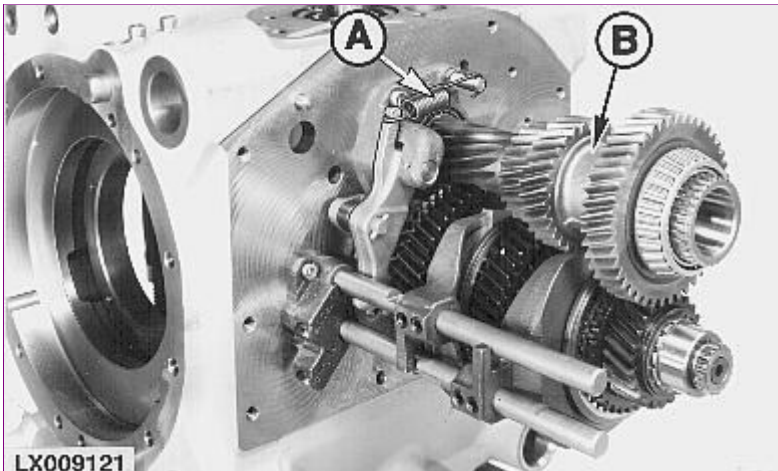

LX009121
LX009121-UN: Spring & Drive Shaft

Disconnect spring (A) and remove drive shaft (B).

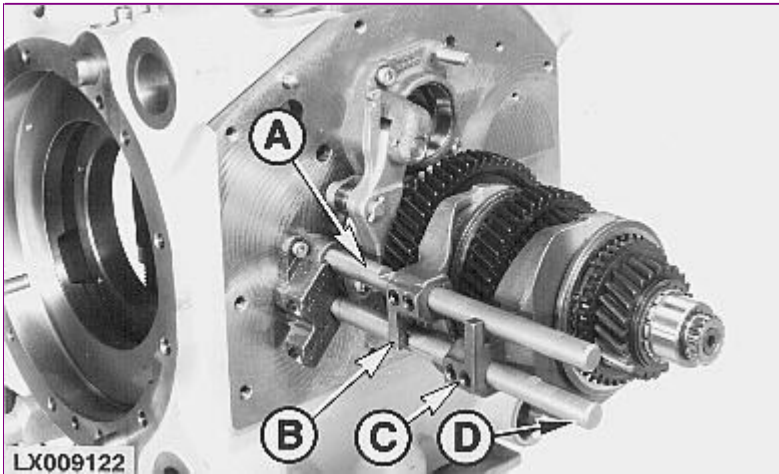

LX009122-UN: Shift Shafts & Forks

LEGEND:

- A - Shifter shaft (ranges A and B)
- B - Shifter fork (ranges A and B)
- C - Shifter fork (ranges C and D)
- D - Shifter shaft (ranges C and D)

Remove shifter shafts and shifter forks.

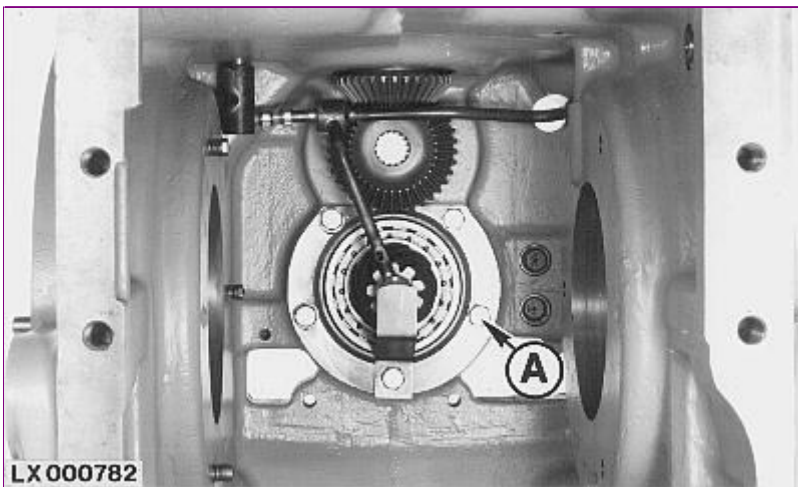

LX000782-UN: Diff. Drive Shaft Cap Screws

Turn out cap screws (A) and remove differential drive shaft.

tm4523 - 6200, 6200L, 6300, 6300L, 6400, 6400L, 6500, 6500L Tractors
 Exploded View of Differential Drive Shaft

Exploded View of Differential Drive Shaft

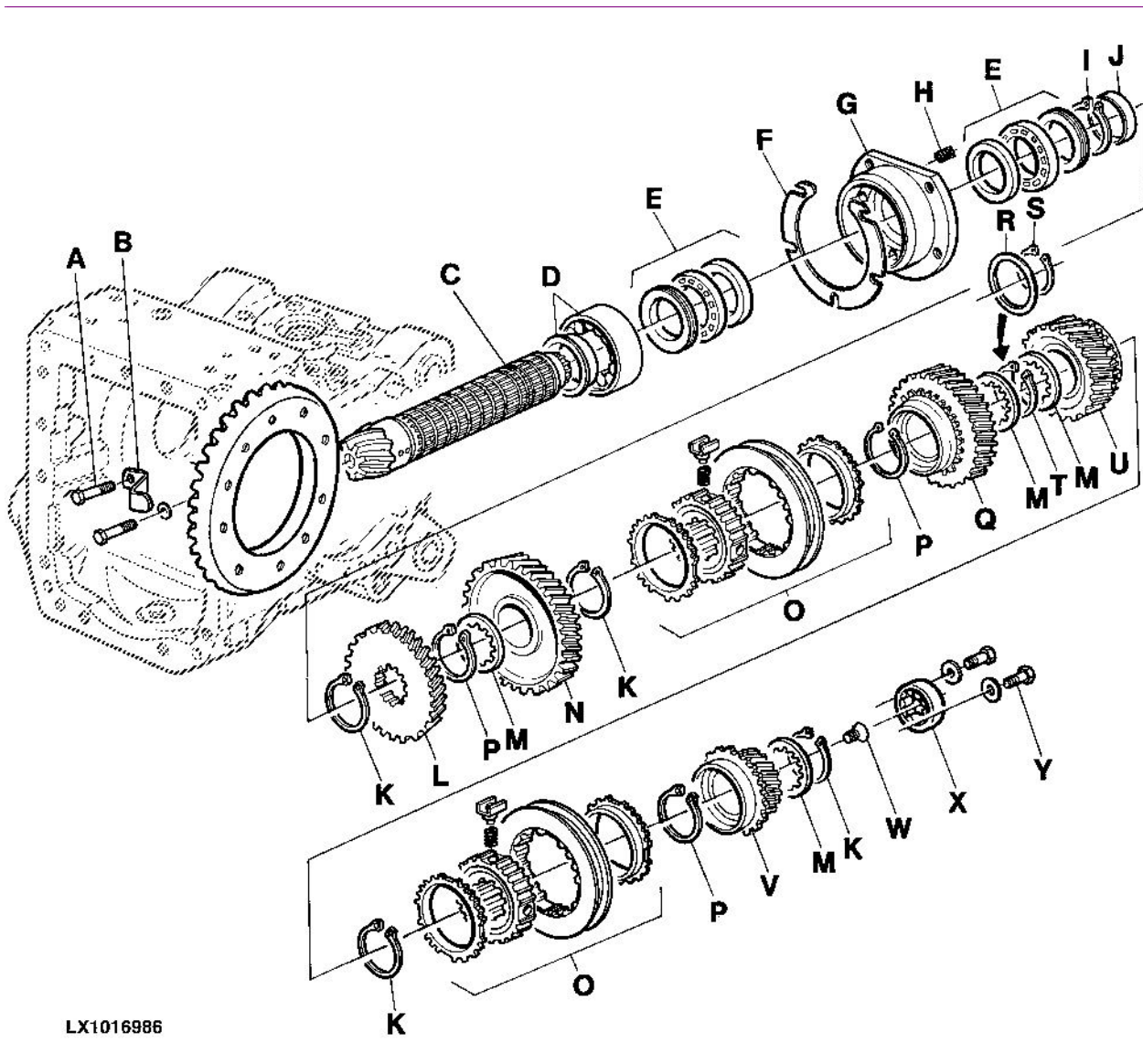

LX1016986

LX1016986-UN: Differential Drive Shaft

LEGEND:

- A - Cap screw (5 used)
- B - Bracket
- C - Differential drive shaft
- D - Needle bearing assy.
- E - Axial bearing assy.
- F - Shim (use as required)
- G - Bearing quill
- H - Spring (5 used)
- I - Snap ring (thickness as required)
- J - Spacer [Earlier tractor series]
- K - Snap ring
- L - Front wheel drive gear
- M - Thrust washer (thickness as required)
- N - Gear of range A
- O - Synchronizer assy.
- P - Snap ring (thickness as required)
- Q - Gear of range B
- R - Washer (up to transm. serial no. 157465)
- S - Snap ring (2.0 m; 0.079 in. thick; up to transm. serial no. 57465)
- T - Snap ring (3.0 m; 0.118 n. thick; from transm. serial no. 57466)
- U - Gear of range C
- V - Gear of range D
- W - Countersunk screw
- X - Needle bearing
- Y - Cap screw (1 [Later tractor series] [Earlier tractor series] used)

tm4523 - 6200, 6200L, 6300, 6300L, 6400, 6400L, 6500, 6500L Tractors
 Exploded View of Drive Shaft and Parking Lock

Exploded View of Drive Shaft and Parking Lock

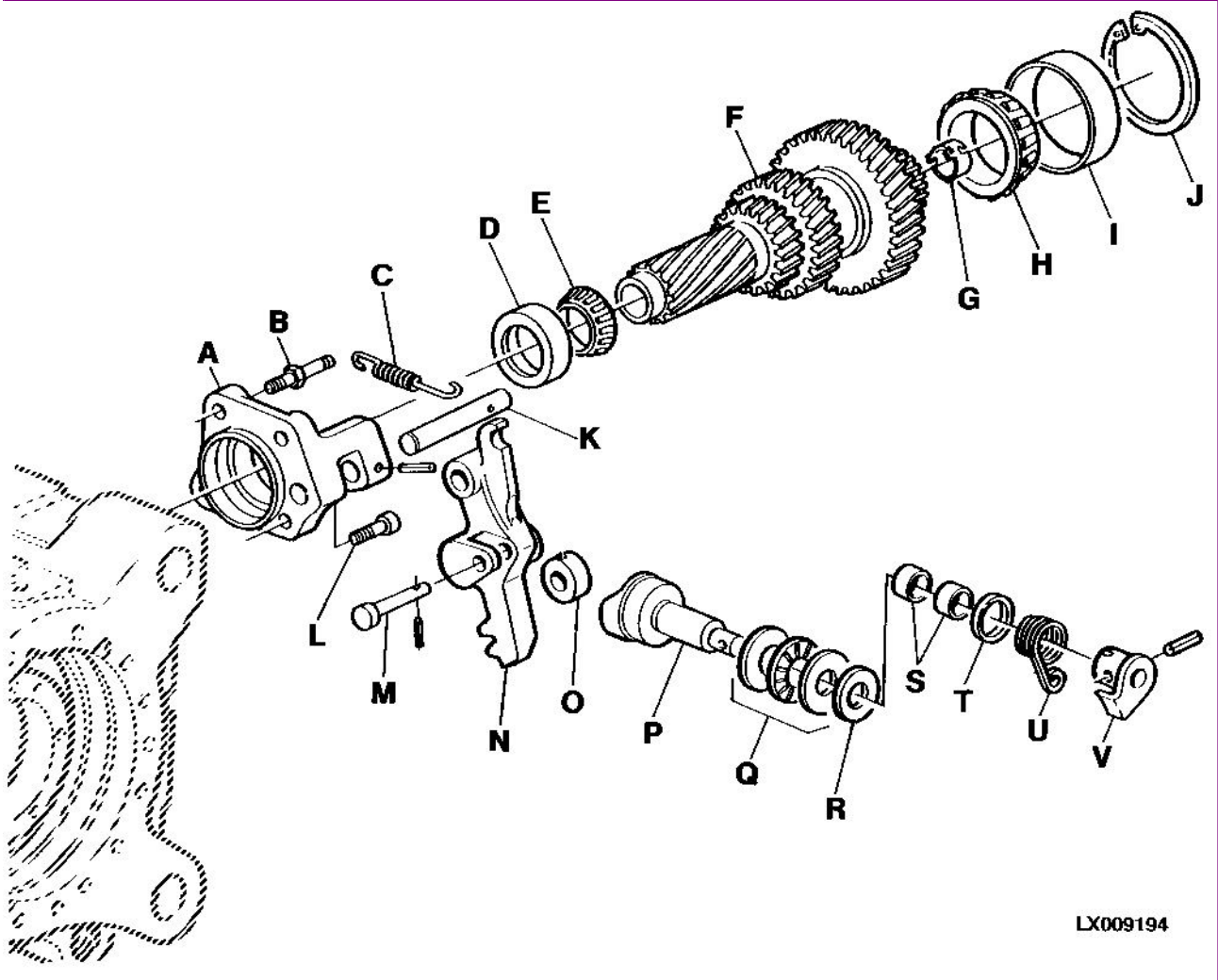

LX009194

LX009194-UN: Drive Shaft & Parking Lock

LEGEND:

- A - Bearing quill
- B - Pin
- C - Spring
- D - Taper roller bearing cup
- E - Taper roller bearing cone
- F - Drive shaft
- G - Sealing sleeve (older tractors only)
- H - Taper roller bearing cone
- I - Taper roller bearing cup
- J - Snap ring
- K - Shaft
- L - Hex. socket screw
- M - Pin
- N - Locking latch
- O - Roller
- P - Shifter cam
- Q - Axial bearing assy.
- R - Spacer washer (thickness as required)
- S - Bushing
- T - Seal ring
- U - Spring
- V - Lever

**tm4523 - 6200, 6200L, 6300, 6300L, 6400, 6400L, 6500, 6500L Tractors
Exploded View of Shift Mechanism**

Exploded View of Shift Mechanism

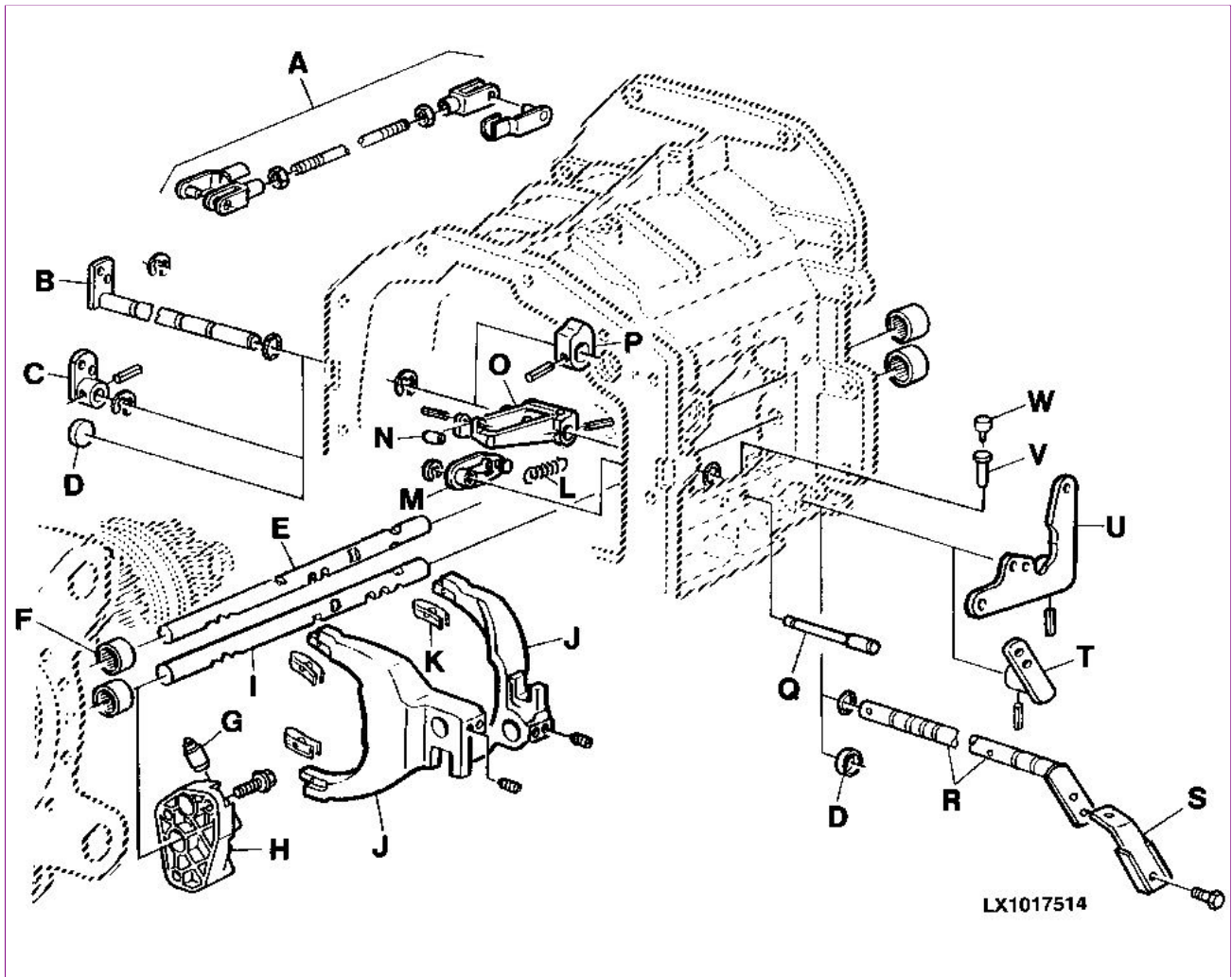

LX1017514-UN: Shift Mechanism

LEGEND:

- A - Forward/reverse linkage assembly [PowrQuad transmission]
- B - Fwd/rev. shifter shaft [PowrQuad transmission]
- C - Lever [PowrQuad transmission] [Up to transmission serial no. 156441]
- D - Cover [SyncroPlus or PowrQuad transm. with el. reverser control on steering column]
- E - Shifter shaft
- F - Ball bushing (4 used)
- G - Locking pin (2 used)
- H - Shifter shaft housing
- I - Shifter shaft
- J - Shift fork
- K - Plastic tips (4 used) (latest tractor series)
- L - Spring [If equipped]
- M - Lever [If equipped]
- N - Roller [If equipped]
- O - Lever [If equipped]
- P - Cam [PowrQuad transmission] [Up to transmission serial no. 173498]
- Q - Dowel pin [If equipped]
- R - Fwd/rev. shifter shaft [PowrQuad transmission] [Up to transmission serial no. 156441]
- S - Lever [PowrQuad transmission] [Up to transmission serial no. 156441]
- T - Lever [PowrQuad transmission]
- U - Lever [PowrQuad transmission]
- V - Pin [PowrQuad transmission] [Up to transmission serial no. 173498]
- W - Pin [PowrQuad transmission] [Up to transmission serial no. 173498]



Suggest:

If the above button click is invalid.

Please download this document

first, and then click the above link

to download the complete manual.

Thank you so much for reading

tm4523 - 6200, 6200L, 6300, 6300L, 6400, 6400L, 6500, 6500L Tractors Exploded View of Shift Cover

Exploded View of Shift Cover

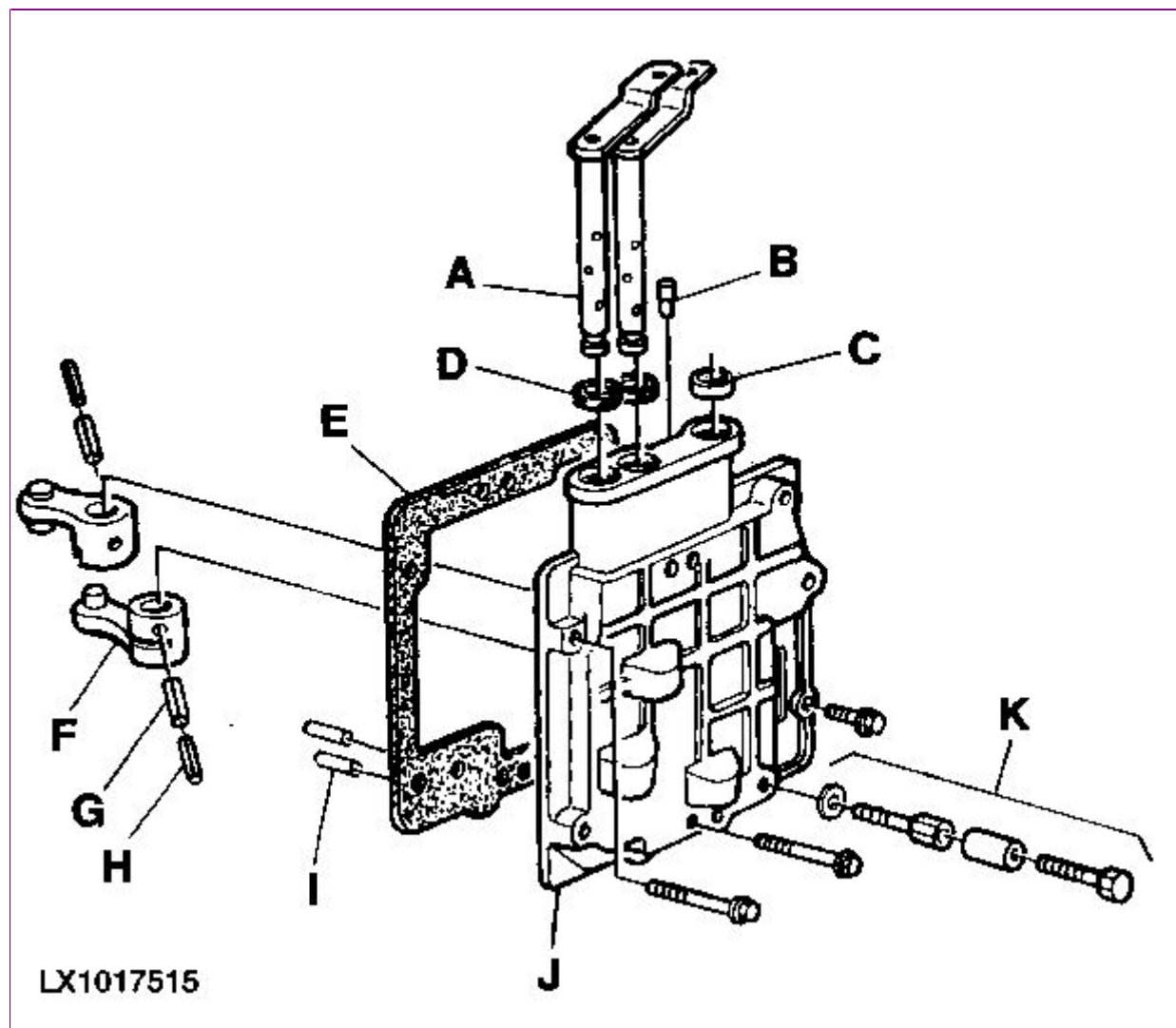

LX1017515-UN: Shift Cover

LEGEND:

- A - Shifter shaft (2 used)
- B - Pin
- C - Cover
- D - Seal
- E - Seal
- F - Lever (2 St.)
- G - 8 mm (5/16 in.) dia. spring pin (2 used)
- H - 5 mm (13/64 in.) dia. spring pin (2 used)
- I - Dowel Pin (2 used)
- J - Shift Cover
- K - Stop Assembly (prevents sticking; if equipped)

Repairing the shaft cover

NOTE:

Use an M6 screw to extract dowel pins (I).

<https://www.ebooklibonline.com>

Hello dear friend!

Thank you very much for reading.

Enter the link into your browser.

The full manual is available for immediate download.

<https://www.ebooklibonline.com>