

5220, 5320, 5420, and 5520 Tractor Repair

TECHNICAL MANUAL 5220, 5320, 5420, and 5520 Tractor Repair

TM2048 15MAR02 (ENGLISH)

For complete service information also see:

5220, 5320, 5420, and 5520 Tractor Operation and Test	TM2049
Component Technical Manual 4045 Engine	CTM104
Component Technical Manual 4045 Mechanical Fuel System	CTM207
Component Technical Manual 3029 Engine	CTM125
Alternators and Starting Motors.....	CTM77

John Deere Augusta Works
LITHO IN U.S.A.

Introduction

Foreword

This manual is written for an experienced technician. Essential tools required in performing certain service work are identified in this manual and are recommended for use.

Live with safety: Read the safety messages in the introduction of this manual and the cautions presented throughout the text of the manual.



This is the safety-alert symbol. When you see this symbol on the machine or in this manual, be alert to the potential for personal injury.

Technical manuals are divided in two parts: repair and operation and tests. Repair sections tell how to repair the components. Operation and tests sections help you identify the majority of routine failures quickly.

Information is organized in groups for the various components requiring service instruction. At the beginning of each group are summary listings of all applicable essential tools, service equipment and tools, other materials needed to do the job, service parts kits, specifications, wear tolerances, and torque values.

Technical Manuals are concise guides for specific machines. They are on-the-job guides containing only the vital information needed for diagnosis, analysis, testing, and repair.

Fundamental service information is available from other sources covering basic theory of operation, fundamentals of troubleshooting, general maintenance, and basic type of failures and their causes.

DX, TMIFC -19-29SEP98-1/1

Contents

SECTION 10—General Information

- Group 05—Safety
- Group 10—General Specifications
- Group 20—Fuel and Lubricants
- Group 25—Serial Number Locations
- Group 30—Features and Accessories

SECTION 20—Engine Repair

- Group 05—Engine
- Group 10—Cooling System

SECTION 30—Fuel and Air Repair

- Group 05—Fuel System
- Group 10—Air Intake System
- Group 15—Speed Control Linkage

SECTION 40—Electrical Repair

- Group 05—Battery, Starter and Alternator
- Group 10—Electrical System Components
- Group 15—Wiring Harness

SECTION 50—Power Train Repair

- Group 05—Clutch Housing
- Group 10—Clutch Assembly—
CollarShift/SyncShuttle™ Transmissions
- Group 11—Clutch Assembly—PowrReverser™
Transmission
- Group 12—PowrReverser™
- Group 15—CollarShift/SyncShuttle™ Transmission
- Group 16—PowrReverser™ Transmission
- Group 20—Rear PTO Drive Shaft
- Group 25—Differential
- Group 30—Final Drives
- Group 31—Hi-Crop Final Drives
- Group 35—Mechanical Front Wheel Drive
- Group 40—Creeper Assembly

SECTION 60—Steering and Brake Repair

- Group 05—Steering Repair
- Group 10—Brake Repair

SECTION 70—Hydraulic Repair

- Group 05—Hydraulic Pump and Filter
- Group 06—Hydraulic Oil Cooler

- Group 10—Rockshaft
- Group 15—Selective Control Valve
- Group 20—Hydraulic Mid Mount Control Valve

SECTION 80—Miscellaneous Repair

- Group 05—Front Axle—2WD
- Group 10—Wheels
- Group 15—3-Point Hitch
- Group 20—Fenders

SECTION 90—Operator Station Repair

- Group 05—Seat and Support
- Group 06—Control Console and Panel
- Group 10—ROLL-GARD
- Group 15—Cab Components
- Group 16—Isolated Open Operator Station
Components
- Group 20—Air Conditioning System
- Group 25—Heating System

All information, illustrations and specifications in this manual are based on the latest information available at the time of publication. The right is reserved to make changes at any time without notice.

COPYRIGHT © 2002
DEERE & COMPANY
Moline, Illinois
All rights reserved
A John Deere ILLUSTRATION® Manual

10

20

30

40

50

60

70

80

90

INDX

<https://www.ebooklibonline.com>

Hello dear friend!

Thank you very much for reading.

Enter the link into your browser.

The full manual is available for immediate download.

<https://www.ebooklibonline.com>

Contents

10

20

30

40

50

60

70

80

90

INDX

Section 10

General Information

Contents

Page	Page
Group 05—Safety	10-05-1
Group 10—General Specifications	
Machine Specifications 5220 and 5320	10-10-1
Machine Specifications 5420 and 5520	10-10-6
Collar Shift and SyncShuttle™	
Transmission Ground Speed Estimates	10-10-11
Collar Shift and SyncShuttle™ Creeper	
Transmissions Ground Speed Estimates	10-10-12
PowrReverser™ Transmission Ground Speed	
Estimates	10-10-13
PowrReverser Creeper Transmissions	
Ground Speed Estimates	10-10-14
Correction Factors for Other Tire Sizes	10-10-15
Machine Dimensions (Straddle Mount)	10-10-16
Machine Dimensions (5520 Series Hi-Crop	
Straddle Mount)	10-10-18
Machine Dimensions (Isolated Open Operator	
Station)	10-10-19
Machine Dimensions (Cab)	10-10-21
Repair Specifications	10-10-23
Service Recommendations for O-Ring	
Boss Fittings	10-10-35
Service Recommendations for Flat Face	
O-Ring Seal Fittings	10-10-37
Metric Cap Screw Torque Values—Grade	
7	10-10-38
Metric Bolt and Cap Screw Torque Values	10-10-39
Unified Inch Bolt and Cap Screw Torque	
Values	10-10-40
Abbreviations	10-10-41
Group 20—Fuel and Lubricants	
Diesel Fuel Specifications	10-20-1
Storing Fuel	10-20-1
Do Not Use Galvanized Containers	10-20-2
Fill Fuel Tank	10-20-3
Diesel Engine Oil	10-20-4
Diesel Engine Coolant	10-20-5
Liquid Coolant Conditioner	10-20-6
Transmission and Hydraulic Oil	10-20-7
MFWD Gear Oil	10-20-8
Grease (Specific Application)	10-20-8
Grease	10-20-9
Alternative and Synthetic Lubricants	10-20-10
Lubricant Storage	10-20-10
Group 25—Serial Number Locations	
Serial Numbers	10-25-1
Product Identification Number Location	10-25-1
Engine Serial Number Location	10-25-1
Fuel Injection Pump Serial Number Location	10-25-1
Alternator Serial Number Location	10-25-2
Power Steering Valve Serial Number	
Location	10-25-2
Starter Serial Number Location	10-25-2
Transmission Serial Number Location	10-25-2
Front Axle (2WD) Serial Number Location	10-25-3
Mechanical Front Wheel Drive (MFWD) Serial	
Number Location	10-25-3
Air Conditioning Compressor Serial Number	
Location	10-25-3
Group 30—Features and Accessories	
Features and Accessories	10-30-1
Standard Features—Straddle Mount and	
Isolated Open Operator Station Tractors	10-30-2
Standard Features—Cab Tractor	10-30-4
Standard Features—5520 Hi-Crop Straddle	
Mount Tractors	10-30-5
Standard Features—5220 through 5520	10-30-6
Factory Installed Optional Equipment	
(5220—5520)	10-30-7
Field Installed Optional Kits and	
Accessories—5220 through 5520	10-30-8

Recognize Safety Information

This is a safety-alert symbol. When you see this symbol on your machine or in this manual, be alert to the potential for personal injury.

Follow recommended precautions and safe operating practices.



DX,ALERT -19-29SEP98-1/1

TS1389 -UN-07DEC88

Understand Signal Words

A signal word—DANGER, WARNING, or CAUTION—is used with the safety-alert symbol. DANGER identifies the most serious hazards.

DANGER or WARNING safety signs are located near specific hazards. General precautions are listed on CAUTION safety signs. CAUTION also calls attention to safety messages in this manual.



▲ WARNING

▲ CAUTION

DX,SIGNAL -19-03MAR93-1/1

TS187 -19-30SEP88

Follow Safety Instructions

Carefully read all safety messages in this manual and on your machine safety signs. Keep safety signs in good condition. Replace missing or damaged safety signs. Be sure new equipment components and repair parts include the current safety signs. Replacement safety signs are available from your John Deere dealer.

Learn how to operate the machine and how to use controls properly. Do not let anyone operate without instruction.

Keep your machine in proper working condition. Unauthorized modifications to the machine may impair the function and/or safety and affect machine life.

If you do not understand any part of this manual and need assistance, contact your John Deere dealer.



DX,READ -19-03MAR93-1/1

TS201 -UN-23AUG88

Handle Fluids Safely—Avoid Fires

When you work around fuel, do not smoke or work near heaters or other fire hazards.

Store flammable fluids away from fire hazards. Do not incinerate or puncture pressurized containers.

Make sure machine is clean of trash, grease, and debris.

Do not store oily rags; they can ignite and burn spontaneously.



TS227 -UN-23AUG88

DX,FLAME -19-29SEP98-1/1

Prevent Battery Explosions

Keep sparks, lighted matches, and open flame away from the top of battery. Battery gas can explode.

Never check battery charge by placing a metal object across the posts. Use a volt-meter or hydrometer.

Do not charge a frozen battery; it may explode. Warm battery to 16°C (60°F).



TS204 -UN-23AUG88

DX,SPARKS -19-03MAR93-1/1

Prepare for Emergencies

Be prepared if a fire starts.

Keep a first aid kit and fire extinguisher handy.

Keep emergency numbers for doctors, ambulance service, hospital, and fire department near your telephone.

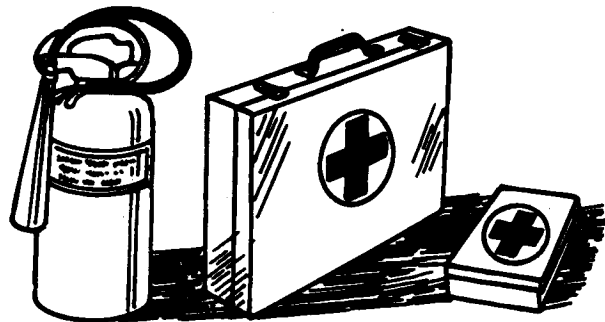

TS291 -UN-23AUG88

DX,FIRE2 -19-03MAR93-1/1

Prevent Acid Burns

Sulfuric acid in battery electrolyte is poisonous. It is strong enough to burn skin, eat holes in clothing, and cause blindness if splashed into eyes.

Avoid the hazard by:

1. Filling batteries in a well-ventilated area.
2. Wearing eye protection and rubber gloves.
3. Avoiding breathing fumes when electrolyte is added.
4. Avoiding spilling or dripping electrolyte.
5. Use proper jump start procedure.

If you spill acid on yourself:

1. Flush your skin with water.
2. Apply baking soda or lime to help neutralize the acid.
3. Flush your eyes with water for 15—30 minutes. Get medical attention immediately.

If acid is swallowed:

1. Do not induce vomiting.
2. Drink large amounts of water or milk, but do not exceed 2 L (2 quarts).
3. Get medical attention immediately.

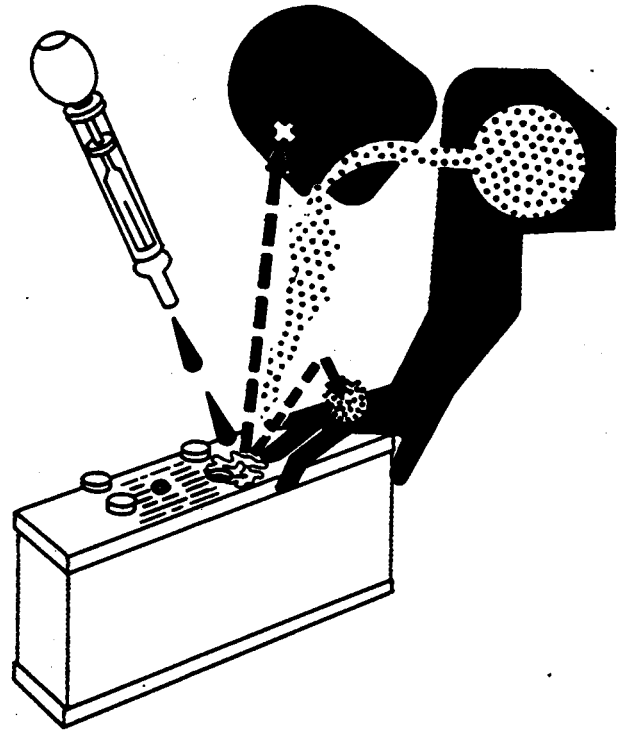

TS203 -UN-23AUG88

DX,POISON -19-21APR93-1/1

Service Cooling System Safely

Explosive release of fluids from pressurized cooling system can cause serious burns.

Shut off engine. Only remove filler cap when cool enough to touch with bare hands. Slowly loosen cap to first stop to relieve pressure before removing completely.



TS281 -UN-23AUG88

DX,RCAP -19-04JUN90-1/1

Handle Chemical Products Safely

Direct exposure to hazardous chemicals can cause serious injury. Potentially hazardous chemicals used with John Deere equipment include such items as lubricants, coolants, paints, and adhesives.

A Material Safety Data Sheet (MSDS) provides specific details on chemical products: physical and health hazards, safety procedures, and emergency response techniques.

Check the MSDS before you start any job using a hazardous chemical. That way you will know exactly what the risks are and how to do the job safely. Then follow procedures and recommended equipment.

(See your John Deere dealer for MSDS's on chemical products used with John Deere equipment.)



TS1132 -UN-26NOV90

DX,MSDS,NA -19-03MAR93-1/1

Avoid High-Pressure Fluids

Escaping fluid under pressure can penetrate the skin causing serious injury.

Avoid the hazard by relieving pressure before disconnecting hydraulic or other lines. Tighten all connections before applying pressure.

Search for leaks with a piece of cardboard. Protect hands and body from high pressure fluids.

If an accident occurs, see a doctor immediately. Any fluid injected into the skin must be surgically removed within a few hours or gangrene may result. Doctors unfamiliar with this type of injury should reference a knowledgeable medical source. Such information is available from Deere & Company Medical Department in Moline, Illinois, U.S.A.

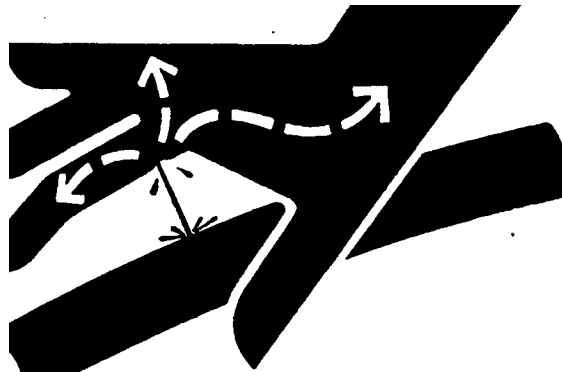

X9811 -UN-23AUG88

DX,FLUID -19-03MAR93-1/1

Park Machine Safely

Before working on the machine:

- Lower all equipment to the ground.
- Shift transmission to PARK.
- Engage park brake if equipped.
- Stop the engine and remove the key.
- Disconnect the battery ground strap.
- Hang a "DO NOT OPERATE" tag in operator station.

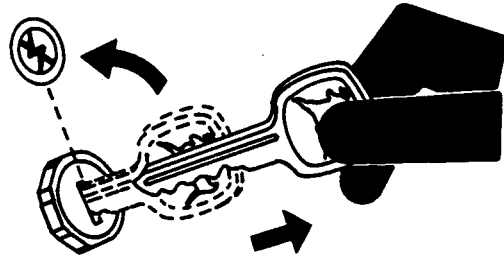

TS230 -UN-24MAY89

CED,OUO1085,7 -19-26JUL00-1/1

Support Machine Properly

Always lower the attachment or implement to the ground before you work on the machine. If you must work on a lifted machine or attachment, securely support the machine or attachment.

Do not support the machine on cinder blocks, hollow tiles, or props that may crumble under continuous load. Do not work under a machine that is supported solely by a jack. Follow recommended procedures in this manual.

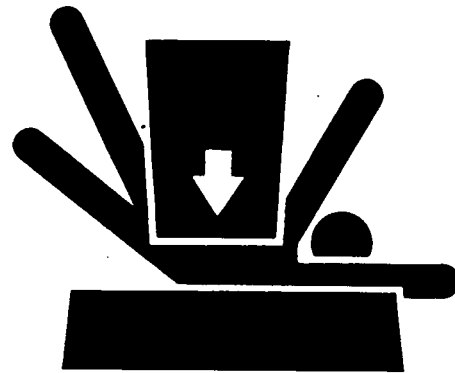

TS229 -UN-23AUG88

CED,OUO1085,8 -19-26JUL00-1/1

Wear Protective Clothing

Wear close fitting clothing and safety equipment appropriate to the job.

Prolonged exposure to loud noise can cause impairment or loss of hearing.

Wear a suitable hearing protective device such as earmuffs or earplugs to protect against objectionable or uncomfortable loud noises.

Operating equipment safely requires the full attention of the operator. Do not wear radio or music headphones while operating machine.

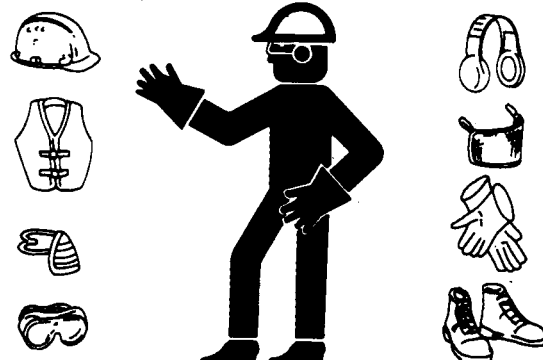

TS206 -UN-23AUG88

DX,WEAR -19-10SEP90-1/1

Work in Clean Area

Before starting a job:

- Clean work area and machine.
- Make sure you have all necessary tools to do your job.
- Have the right parts on hand.
- Read all instructions thoroughly; do not attempt shortcuts.

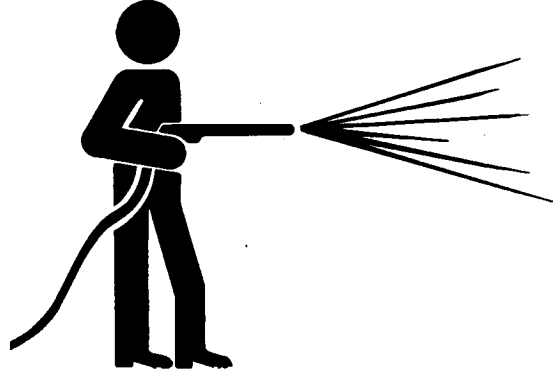

DX,CLEAN -19-04JUN90-1/1

T6642EJ -UN-18OCT88

Service Machines Safely

Tie long hair behind your head. Do not wear a necktie, scarf, loose clothing, or necklace when you work near machine tools or moving parts. If these items were to get caught, severe injury could result.

Remove rings and other jewelry to prevent electrical shorts and entanglement in moving parts.

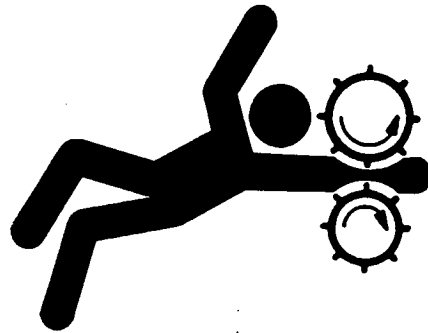

DX,LOOSE -19-04JUN90-1/1

TS228 -UN-23AUG88

Work in Ventilated Area

Engine exhaust fumes can cause sickness or death. If it is necessary to run an engine in an enclosed area, remove the exhaust fumes from the area with an exhaust pipe extension.

If you do not have an exhaust pipe extension, open the doors and get outside air into the area

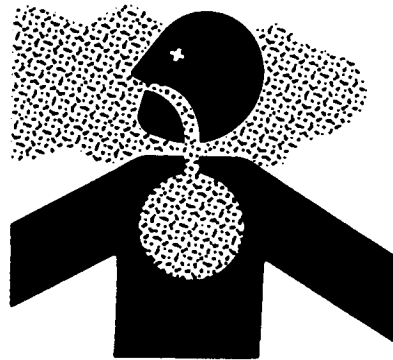

DX,AIR -19-17FEB99-1/1

TS220 -UN-23AUG88

Illuminate Work Area Safely

Illuminate your work area adequately but safely. Use a portable safety light for working inside or under the machine. Make sure the bulb is enclosed by a wire cage. The hot filament of an accidentally broken bulb can ignite spilled fuel or oil.

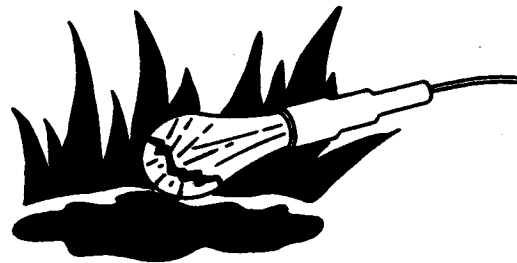

DX,LIGHT -19-04JUN90-1/1

TS223 -UN-23AUG88

Replace Safety Signs

Replace missing or damaged safety signs. See the machine operator's manual for correct safety sign placement.



DX,SIGNS1 -19-04JUN90-1/1

TS201 -UN-23AUG88

Use Proper Lifting Equipment

Lifting heavy components incorrectly can cause severe injury or machine damage.

Follow recommended procedure for removal and installation of components in the manual.

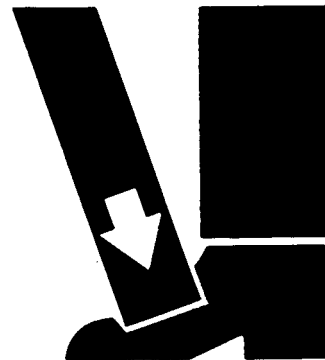

DX,LIFT -19-04JUN90-1/1

TS226 -UN-23AUG88

Keep ROPS Installed Properly

Make certain all parts are reinstalled correctly if the roll-over protective structure (ROPS) is loosened or removed for any reason. Tighten mounting bolts to proper torque.

The protection offered by ROPS will be impaired if ROPS is subjected to structural damage, is involved in an overturn incident, or is in any way altered by welding, bending, drilling, or cutting. A damaged ROPS should be replaced, not reused.

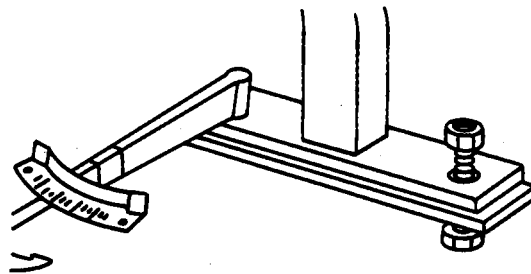

DX,ROPS3 -19-03MAR93-1/1

TS212 -UN-23AUG88

10
05
8

Service Tires Safely

Explosive separation of a tire and rim parts can cause serious injury or death.

Do not attempt to mount a tire unless you have the proper equipment and experience to perform the job.

Always maintain the correct tire pressure. Do not inflate the tires above the recommended pressure. Never weld or heat a wheel and tire assembly. The heat can cause an increase in air pressure resulting in a tire explosion. Welding can structurally weaken or deform the wheel.

When inflating tires, use a clip-on chuck and extension hose long enough to allow you to stand to one side and NOT in front of or over the tire assembly. Use a safety cage if available.

Check wheels for low pressure, cuts, bubbles, damaged rims or missing lug bolts and nuts.

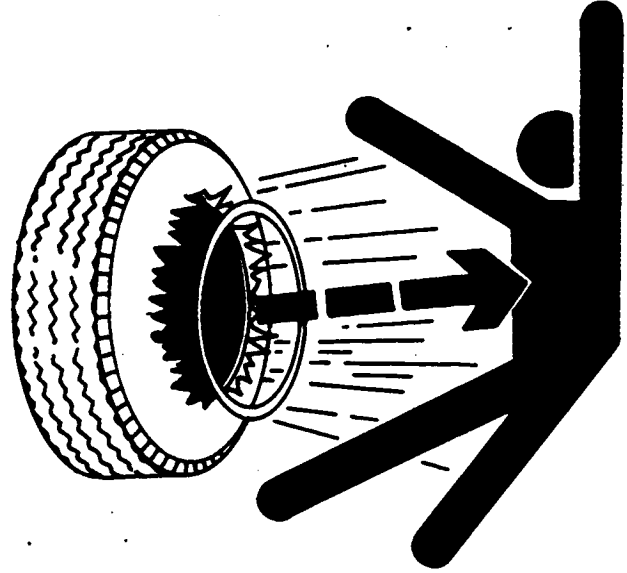

TS211 -UN-23AUG88

DX,RIM -19-24AUG90-1/1

Avoid Harmful Asbestos Dust

Avoid breathing dust that may be generated when handling components containing asbestos fibers. Inhaled asbestos fibers may cause lung cancer.

Components in products that may contain asbestos fibers are brake pads, brake band and lining assemblies, clutch plates, and some gaskets. The asbestos used in these components is usually found in a resin or sealed in some way. Normal handling is not hazardous as long as airborne dust containing asbestos is not generated.

Avoid creating dust. Never use compressed air for cleaning. Avoid brushing or grinding material containing asbestos. When servicing, wear an approved respirator. A special vacuum cleaner is recommended to clean asbestos. If not available, apply a mist of oil or water on the material containing asbestos.

Keep bystanders away from the area.

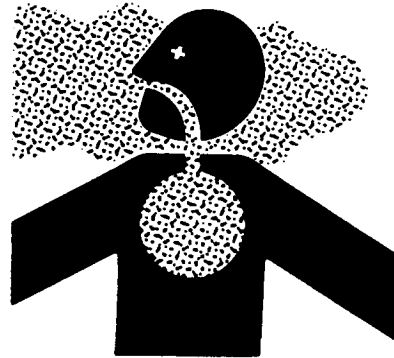

TS220 -UN-23AUG88

DX,DUST -19-15MAR91-1/1

Avoid Heating Near Pressurized Fluid Lines

Flammable spray can be generated by heating near pressurized fluid lines, resulting in severe burns to yourself and bystanders. Do not heat by welding, soldering, or using a torch near pressurized fluid lines or other flammable materials. Pressurized lines can be accidentally cut when heat goes beyond the immediate flame area.



TS953 -JUN-15MAY90

DX.TORCH -19-03MAR93-1/1

Remove Paint Before Welding or Heating

Avoid potentially toxic fumes and dust.

Hazardous fumes can be generated when paint is heated by welding, soldering, or using a torch.

Remove paint before heating:

- Remove paint a minimum of 76 mm (3 in.) from area to be affected by heating.
- If you sand or grind paint, avoid breathing the dust. Wear an approved respirator.
- If you use solvent or paint stripper, remove stripper with soap and water before welding. Remove solvent or paint stripper containers and other flammable material from area. Allow fumes to disperse at least 15 minutes before welding or heating.

Do all work in an area that is ventilated to carry toxic fumes and dust away.

Dispose of paint and solvent properly.

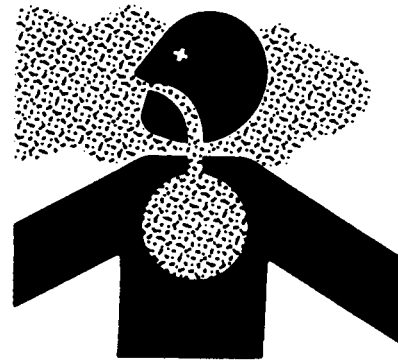

TS220 -JUN-23AUG88

DX.PAINT -19-03MAR93-1/1

10
05
10

Use Proper Tools

Use tools appropriate to the work. Makeshift tools and procedures can create safety hazards.

Use power tools only to loosen threaded parts and fasteners.

For loosening and tightening hardware, use the correct size tools. DO NOT use U.S. measurement tools on metric fasteners. Avoid bodily injury caused by slipping wrenches.

Use only service parts meeting John Deere specifications.



TS779 -UN-08NOV89

DX,REPAIR -19-17FEB99-1/1

Dispose of Waste Properly

Improperly disposing of waste can threaten the environment and ecology. Potentially harmful waste used with John Deere equipment include such items as oil, fuel, coolant, brake fluid, filters, and batteries.

Use leakproof containers when draining fluids. Do not use food or beverage containers that may mislead someone into drinking from them.

Do not pour waste onto the ground, down a drain, or into any water source.

Air conditioning refrigerants escaping into the air can damage the Earth's atmosphere. Government regulations may require a certified air conditioning service center to recover and recycle used air conditioning refrigerants.

Inquire on the proper way to recycle or dispose of waste from your local environmental or recycling center, or from your John Deere dealer.

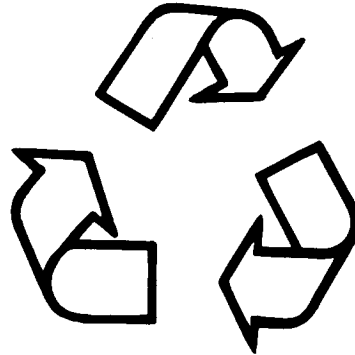

TS1133 -UN-26NOV90

DX,DRAIN -19-03MAR93-1/1

Live With Safety

Before returning machine to customer, make sure machine is functioning properly, especially the safety systems. Install all guards and shields.



10
05
11

TS231 -19-07OCT88

DX,LIVE -19-25SEP92-1/1

Machine Specifications 5220 and 5320

NOTE: Specifications and design subject to change without notice.

5220 Tractor

Item	Measurement	Specification
Engine	Make	John Deere
	Type	Diesel
	Model	PE3029DLV53
	Aspiration	Natural
	Horsepower	40 kW (53 hp)
	Rated Engine Speed	2400 rpm
	Operating Range	1600—2400 rpm
	Number of Cylinders	3
	Displacement	2.9 L (179 cu in.)
	Bore and Stroke	106 x 110 mm (4.19 x 4.33 in.)
	Compression Ratio	17.8:1
	Fast Idle	2625 ± 25 rpm
	Slow Idle	825 ± 25 rpm
	Start Aid	Air Intake Heater (Optional)
	Firing Order	1-2-3
	Timing	18° BTDC
	Lubrication	Pressurized
Cooling	Liquid Cooled	
Air Cleaner	Dry Type w/Safety Element	
Engine Shutoff	Key Switch	
Fuel System	Type	Direct Injection
	Injection Pump Type	Rotary w/Electric Shutoff
Electrical System	Type	12 Volt
	Battery Size	950 Cold Cranking Amps
	Alternator Without Cab	40 Amp
	Alternator With Cab	60 Amp

Continued on next page

OUO1023,0000316 -19-26FEB02-1/5

General Specifications

10
10
2

Item	Measurement	Specification
Drive Train	Transmission Type	CollarShift (Standard) SyncShuttle™ (Optional) SyncShuttle™ with Shiftable 540/540E PTO (Optional) PowrReverser™ (Optional)
	Number of Speeds	9 Forward, 3 Reverse (SyncShuttle™) 12 Forward, 12 Reverse (PowrReverser™)
	Final Drive Clutch	Planetary Dual, Dry Multi-Disk, Wet (PowrReverser™)
Steering/Brakes	Steering Brakes	Hydrostatic Power Wet Disk Self-Equalizing Self-Adjusting
Hydraulic System	Type	Open Center
	Working Pressure	18,995—19,695 kPa (190—197 bar) (2,755—2,855 psi)
	Pump Type	Tandem Gear
	Capacity	(68.8 L/min 18.2 gpm)
	Hitch Lift Capacity at 610 mm (24 in.) Behind Hitch Balls	1530 kg (3374 lb)
	Lift Control Type	Position and Depth

Continued on next page

OUC1023.0000316 -19-26FEB02-2/5

General Specifications

10
10
3

Item	Measurement	Specification	
Rear PTO ¹	Type	Fully Independent	
	Horsepower (Standard Mode)	34 kW (45 hp)	
	Speed (540 Standard Mode) @ 2400 rpm Engine Speed	540 rpm	
	Speed (540E Economy Mode) @ 1700 rpm Engine Speed	540 rpm	
Capacities	Fuel Tank (Straddle Mount)	68 L (18 gal)	
	Fuel Tank (Isolated Open Operator Station and Cab Tractors)	102.2 L (27 gal)	
	Cooling System	9.5 L (10 qt)	
	Engine Crankcase w/Filter	8.5 L (9 qt)	
	Hydraulic System	With CollarShift or SyncShuttle™	Transmission 38 L (10 gal)
		With PowrReverser™	Transmission 43.5 L (11.5 gal)
	MFWD Wheel Hubs	0.6 L (0.63 qt)	
MFWD Differential Housing	5 L (5.3 qt)		

¹540E Economy Mode available only on SyncSuttle™ Transmission.

Continued on next page

OOU1023,0000316 -19-26FEB02-3/5

General Specifications

10
10
4

5320 Tractor

Item	Measurement	Specification
Engine	Make	John Deere
	Type	Diesel
	Model	PE3029TLV52
	Aspiration	Turbocharged
	Horsepower	48 kW (64 hp)
	Rated Engine Speed	2400 rpm
	Operating Range	1600—2400 rpm
	Number of Cylinders	3
	Displacement	2.9 L (179 cu in.)
	Bore and Stroke	106 x 110 mm (4.19 x 4.33 in.)
	Compression Ratio	17.8:1
	Fast Idle	2625 ± 25 rpm
	Slow Idle	825 ± 25 rpm
	Start Aid	Air Heater (Optional)
	Firing Order	1-2-3
	Timing	7° BTDC
	Lubrication	Pressurized
Cooling	Liquid Cooled	
Air Cleaner	Dry Type w/Safety Element	
Engine Shutoff	Key Switch	
Fuel System	Type	Direct Injection
	Injection Pump Type	Rotary w/Electric Shutoff
Electrical System	Type	12 Volt
	Battery Size	950 Cold Cranking Amps
	Alternator Without Cab	40 Amp
	Alternator With Cab	60 Amp
Drive Train	Transmission Type	CollarShift (Standard)
		SyncShuttle™ (Optional)
		SyncShuttle™ with Shiftable
		540/540E PTO (Optional)
		PowrReverser™ (Optional)
Number of Speeds	9 Forward, 3 Reverse (SyncShuttle™)	
	12 Forward, 12 Reverse (PowrReverser™)	
Final Drive	Planetary	
Clutch	Dual, Dry Multi-Disk, Wet (PowrReverser™)	

Continued on next page

OUC1023.0000316 -19-26FEB02-4/5

General Specifications

10
10
5

Item	Measurement	Specification
Steering/Brakes	Steering Brakes	Hydrostatic Power Wet Disk Self-Equalizing Self-Adjusting
Hydraulic System	Type Working Pressure Pump Type Capacity Hitch Lift Capacity at 610 mm (24 in.) Behind Hitch Balls Lift Control Type	Open Center 18,995—19,685 kPa (190—197 bar) (2,755—2,855 psi) Tandem Gear 68.8 L/min (18.2 gpm) 1530 kg (3374 lb) Position and Depth
Rear PTO ²	Type Horsepower (Standard Mode) Speed (540 Standard Mode) @ 2400 rpm Engine Speed Speed (540E Economy Mode) @ 1700 rpm Engine Speed	Fully Independent 41 kW (55 hp) 540 rpm 540 rpm
Capacities	Fuel Tank (Straddle Mount) Fuel Tank (Isolated Open Operator Station and Cab Tractors) Cooling System Engine Crankcase w/Filter Hydraulic System MFWD Wheel Hubs MFWD Differential Housing	68 L (18 gal) 102.2 L (27 gal) 9.5 L (10 qt) 8.5 L (9 qt) With CollarShift or SyncShuttle™ Transmission 38 L (10 gal) With PowrReverser™ Transmission 43.5 L (11.5 gal) 0.6 L (0.63 qt) 5 L (5.3 qt)

²540E Economy Mode available only on SyncShuttle™ Transmission.

Machine Specifications 5420 and 5520

NOTE: Specifications and design subject to change without notice.

5420 Tractor

Item	Measurement	Specification
Engine	Make	John Deere
	Type	Diesel
	Model	PE4045DLV51
	Aspiration	Natural
	Horsepower	60 kW (81 hp)
	Rated Engine Speed	2400 rpm
	Number of Cylinders	4
	Displacement	4.5 L (274 cu in.)
	Bore and Stroke	106.5 x 127 mm (4.19 x 5.00 in.)
	Compression Ratio	17.6:1
	Fast Idle	2625 ± 25 rpm
	Slow Idle	825 ± 25 rpm
	Start Aid	Air Heater (Optional)
	Firing Order	1-3-4-2
	Timing	9° BTDC
	Lubrication	Pressurized
Cooling	Liquid Cooled	
Air Cleaner	Dry Type w/Safety Element	
Engine Shutoff	Key Switch	
Fuel System	Type	Direct Injection
	Injection Pump Type	Rotary w/Electric Shutoff
Electrical System	Type	12 Volt
	Battery Size	950 Cold Cranking Amps
	Alternator Without Cab	40 Amp
	Alternator With Cab	65 Amp

Continued on next page

OUC1089,0000223 -19-25FEB02-1/5

General Specifications

10
10
7

Item	Measurement	Specification
Drive Train	Transmission Type	CollarShift SyncShuttle™ (Optional) SyncShuttle™ with Shiftable 540/540E PTO (Optional) PowrReverser™ (Optional)
	Number of Speeds	9 Forward, 3 Reverse (SyncShuttle™) 12 Forward, 12 Reverse (PowrReverser™)
	Final Drive Clutch	Planetary Dual, Dry Multi-Disk, Wet (PowrReverser™)
Steering/Brakes	Steering	Hydrostatic Power
	Brakes	Wet Disk Self-Equalizing Self-Adjusting
Hydraulic System	Type Working Pressure	Open Center 18,995—19,685 kPa (190—197 bar) (2,755—2,855 psi)
	Pump Type	Tandem Gear
	Capacity	85 L/min (22.5 gpm)
	Hitch Lift Capacity at 610 mm (24 in.) Behind Hitch Balls	1530 kg (3374 lb)
	Lift Control Type	Position and Depth

Continued on next page

OOU1089,0000223 -19-25FEB02-2/5

General Specifications

10
10
8

Item	Measurement	Specification
Rear PTO ¹	Type	Fully Independent
	Horsepower	48 kW (65 hp)
	Speed (540 Standard Mode) @ 2400 rpm Engine Speed	540 rpm
	Speed (540E Economy Mode) @ 1700 rpm Engine Speed	540 rpm
Capacities	Fuel Tank (Straddle Mount)	68 L (18 gal)
	Fuel Tank (Isolated Open Operator Station and Cab Tractors)	102.2 L (27 gal)
	Cooling System	10.8 L (11.4 qt)
	Engine Crankcase w/Filter	8.5 L (9 qt)
	Hydraulic System	With CollarShift or SyncShuttle™ Transmission 38 L (10 gal) With PowrReverser™ Transmission 43.5 L (11.5 gal)
	MFWD Wheel Hubs	0.6 L (0.63 qt)
	MFWD Axle Housing	5 L (5.3 U.S. qt)

5520 Tractor

Item	Measurement	Specification
Engine	Make	John Deere
	Type	Diesel
	Model	PE4045TLV51
	Aspiration	Turbocharged
	Horsepower	66 kW (89 hp)
	Rated Engine Speed	2400 rpm
	Number of Cylinders	4
	Displacement	4.5 L (274 cu in.)
	Bore and Stroke	106 x 127 mm (4.19 x 5.00 in.)
	Compression Ratio	17.0:1
	Fast Idle	2625 ± 25 rpm
	Slow Idle	825 ± 25 rpm
	Start Aid	Air Heater (Optional)
	Firing Order	1-3-4-2
	Timing	8° BTDC
	Lubrication	Pressurized
Cooling	Liquid Cooled	
Air Cleaner	Dry Type w/Safety Element	
Engine Shutoff	Key Switch	

¹Economy Mode available only on SyncShuttle™ Transmission.

General Specifications

10
10
9

Item	Measurement	Specification
Fuel System	Type Injection Pump Type	Direct Injection Rotary w/Electric Shutoff
Electrical System	Type Battery Size Alternator Without Cab Alternator With Cab	12 Volt 950 Cold Cranking Amps 40 Amp 65 Amp
Drive Train	Transmission Type Number of Speeds Final Drive Final Drive (Hi-Crop Drop Axle) Clutch	CollarShift (Standard) SyncShuttle™ (Optional) SyncShuttle™ with Shiftable 540/540E PTO (Optional) PowrReverser™ (Optional) 9 Forward, 3 Reverse (SyncShuttle™) 12 Forward, 12 Reverse (PowrReverser™) Planetary Gear Case Dual, Dry Multi-Disk, Wet (PowrReverser™)
Steering/Brakes	Steering Brakes	Hydrostatic Power Wet Disk Self-Equalizing Self-Adjusting
Hydraulic System	Type Working Pressure Pump Type Capacity Hitch Lift Capacity at 610 mm (24 in.) Behind Hitch Balls Lift Control Type	Open Center 18,995—19,685 kPa (190—197 bar) (2,755—2,855 psi) Tandem Gear 85 L/min (22.5 gpm) 1530 kg (3374 lb) Position and Depth

Continued on next page

OOU1089,0000223 -19-25FEB02-4/5

General Specifications

10
10
10

Item	Measurement	Specification
Rear PTO ¹	Type	Fully Independent
	Horsepower	56 kW (75 hp)
	Speed (540 Standard Mode) @ 2400 rpm Engine Speed	540 rpm
	Speed (540E Economy Mode) @ 1700 rpm Engine Speed	540 rpm
Capacities	Fuel Tank (Straddle Mount)	83 L (22 gal)
	Fuel Tank (Isolated Open Operator Station and Cab Tractors)	102.2 L (27 gal)
	Cooling System	10.8 L (11.4 qt)
	Engine Crankcase w/Filter	8.5 L (9 qt)
	Hydraulic System (With Standard Rear Axle)	With CollarShift or SyncShuttle™ Transmission 38 L (10 gal) With PowrReverser™ Transmission 43.5 L (11.5 gal)
	Hydraulic System (With Hi-Crop Drop Axle)	CollarShift or SyncShuttle™ Transmission 64 L (17 gal) PowrReverser™ Transmission 70 L (18.5 gal)
	MFWD Wheel Hubs	0.6 L (0.63 qt)
MFWD Axle Housing	5 L (5.3 qt)	

¹Economy Mode available only on SyncShuttle™ Transmission.

OUO1089,0000223 -19-25FEB02-5/5

Collar Shift and SyncShuttle™ Transmission Ground Speed Estimates

Speeds are calculated using 16.9-30, R1 rear tires. To calculate ground speeds for tractors equipped with rear tires other than 16.9-30, R1 tires, see Correction Factors for Other Tire Sizes in this section.

Gear	Operating Range-Forward (1600 to 2400 Engine RPM)	
	mph	km/h
A—1	0.85—1.28	1.37—2.06
A—2	1.23—1.85	1.98—2.97
A—3	1.68—2.52	2.70—4.05
B—1	2.01—3.02	3.24—4.86
B—2	2.91—4.36	4.68—7.02
B—3	3.96—5.95	6.38—9.57
C—1	5.53—8.29	8.90—13.34
C—2	7.98—11.97	12.84—19.26
C—3	10.88—16.32	17.51—26.27
R—1	1.43—2.15	2.31—3.46
R—2	3.38—5.07	5.44—8.17
R—3	9.29—13.93	14.95—22.43

OUO1004.0000CC8 -19-26OCT01-1/1

10
10
12

**Collar Shift and SyncShuttle™ Creeper
Transmissions Ground Speed Estimates**

Speeds are calculated using 16.9-30, R1 rear tires. To calculate ground speeds for tractors equipped with rear tires other than 16.9-30, R1 tires, see Correction Factors for Other Tire Sizes in this section.

Gear	Higher Speed Creeper (1600 to 2400 Engine RPM)	Regular Speed Creeper (1600 to 2400 Engine RPM)
Creeper-1F	0.35—0.53 (mph) 0.56—0.84 (km/h)	0.15—0.22 (mph) 0.24—0.36 (km/h)
Creeper-2F	0.51—0.76 (mph) 0.81—1.22 (km/h)	0.21—0.32 (mph) 0.34—0.52 (km/h)
Creeper-3F	0.69—1.04 (mph) 1.11—1.66 (km/h)	0.29—0.43 (mph) 0.47—0.70 (km/h)
Creeper-1R	0.59—0.89 (mph) 0.95—1.43 (km/h)	0.25—0.37 (mph) 0.40—0.60 (km/h)

OUC1043.0000468 -19-07MAR01-1/1

PowrReverser™ Transmission Ground Speed Estimates

Speeds are calculated using 16.9-30, R1 rear tires. To calculate ground speeds for tractors equipped with rear tires other than 16.9-30, R1 tires, see Correction Factors for Other Tire Sizes in this section.

Gear	Operating Range-Forward (2400 Engine RPM)		Operating Range-Reverse (2400 Engine RPM)	
	mph	km/h	mph	km/h
A—1	0.92	1.49	1.07	1.72
A—2	1.15	1.86	1.33	2.15
A—3	1.49	2.20	1.73	2.78
A—4	1.78	2.86	2.21	3.32
B—1	2.68	4.31	3.10	4.98
B—2	3.35	5.39	3.87	6.23
B—3	4.33	6.97	5.01	8.06
B—4	5.91	9.50	6.83	10.99
C—1	7.57	12.18	8.75	14.08
C—2	9.46	15.22	10.94	17.60
C—3	12.24	19.69	14.15	22.77
C—4	16.69	26.85	19.30	31.05

OUO1043,0000465 -19-07MAR01-1/1

10
10
14

**PowrReverser Creeper Transmissions
Ground Speed Estimates**

Speeds are calculated using 16.9-30, R1 rear tires. To calculate ground speeds for tractors equipped with rear tires other than 16.9-30, R1 tires, see Correction Factors for Other Tire Sizes in this section.

Gear	Higher Speed Creeper (2400 Engine RPM)	Regular Speed Creeper (2400 Engine RPM)
Creeper-1F	0.37 (mph) 0.58 (km/h)	0.15 (mph) 0.24 (km/h)
Creeper-2F	0.45 (mph) 0.73 (km/h)	0.19 (mph) 0.30 (km/h)
Creeper-3F	0.58 (mph) 0.95 (km/h)	0.24 (mph) 0.39 (km/h)
Creeper-4F	0.81 (mph) 1.33 (km/h)	0.33 (mph) 0.54 (km/h)
Creeper-1R	0.42 (mph) 0.68 (km/h)	0.18 (mph) 0.28 (km/h)
Creeper-2R	0.53 (mph) 0.84 (km/h)	0.22 (mph) 0.35 (km/h)
Creeper-3R	0.68 (mph) 1.09 (km/h)	0.28 (mph) 0.45 (km/h)
Creeper-4R	0.95 (mph) 1.48 (km/h)	0.39 (mph) 0.62 (km/h)

OUC1043,0000466 -19-07MAR01-1/1

Correction Factors for Other Tire Sizes

To calculate ground speeds for tractors equipped with rear tires other than 16.9-30, R1, multiply the ground speeds shown for the 16.9-30, R1 tires in Transmission Ground Speed Estimates or Creeper Transmission Ground Speed Estimates for correct transmission in this section by the correction factor for the appropriate tire found in the table below.

Example: B-2 (SyncShuttle™ Transmission) at 2400 engine rpm with 16.9-24 R1 tires.

4.36 mph (7.02 km/h) x 0.90 = 3.92 mph (6.32 km/h)

Tire Size	Correction Factor
21.5L-16.1 R3	0.74
22.5LL-16.1 TS	0.70
16.9-24 R4	0.87
16.9-24 R3	0.88
19.5L-24 R4	0.88
16.9-24 R1	0.90
13.6-28 R1	0.90
14.9-28 R1	0.92
16.9-28 R1	0.97
18.4-30 R1	1.04
15.5-38 R1	1.07
9.5L-48 R1	1.17
13.6-38 R2	1.09

NOTE: Speed and correction factor information above is based on rolling circumference information from Firestone Farm Tire Data Book. Rolling circumference dimensions for "like" size tires vary by manufacturer.

OOU1043,0000467 -19-22FEB02-1/1

General Specifications

Machine Dimensions (Straddle Mount)

Dimension	Tractor							
	5220		5320		5420		5520	
Straddle Mount	2WD mm (in.)	MFWD mm (in.)	2WD mm (in.)	MFWD mm (in.)	2WD mm (in.)	MFWD mm (in.)	2WD mm (in.)	MFWD mm (in.)
Wheel Base	2049.8 (80.7)	2049.8 (80.7)	2049.8 (80.7)	2049.8 (80.7)	2176.8 (85.7)	2176.8 (85.7)	2176.8 (85.7)	2176.8 (85.7)
Overall Length Including Draft Links	3622.0 ^a (142.6)	3622.0 ^a (142.6)	3622.0 ^a (142.6)	3622.0 ^a (142.6)	3848.1 ^a (151.5 ^a)	3848.1 ^a (151.5 ^a)	3848.1 ^a (151.5 ^a)	3848.1 ^a (151.5 ^a)
Overall Width								
Outside Edge of Tires	1648.5 (64.9)	1648.5 (64.9)	1795.8 (70.7)	1795.8 (70.7)	1795.8 (70.7)	1795.8 (70.7)	1963.4 (77.3)	1963.4 (77.3)
Rear Axle Flange-to-Rear Axle Flange	1455.4 (57.3)	1455.4 (57.3)	1455.4 (57.3)	1455.4 (57.3)	1455.4 (57.3)	1455.4 (57.3)	1455.4 (57.3)	1455.4 (57.3)
Ground-to-ROPS Top	2395.2 (94.3)	2395.2 (94.3)	2418.1 (95.2)	2418.1 (95.2)	2468.9 (97.2)	2468.9 (97.2)	2468.9 (97.2)	2468.9 (97.2)
Ground-to-Canopy Top	—	—	—	—	—	—	2641.6 (104.0)	2641.6 (104.0)
Ground-to-Folded ROPS Top	1950.7 (76.8)	1950.7 (76.8)	1973.6 (77.7)	1973.6 (77.7)	2024.4 (79.7)	2024.4 (79.7)	2024.4 (79.7)	2024.4 (79.7)
Hood Top-to-ROPS Top	1346.2 (53.0)	1361.4 (53.6)	1366.5 (53.8)	1389.4 (54.7)	1366.5 (53.8)	1409.7 (55.5)	1366.5 (53.8)	1409.7 (55.5)
Steering Wheel Top-to-ROPS Top	1612.9 (63.5)	1623.1 (63.9)	1635.8 (64.4)	1648.5 (64.9)	1661.2 (65.4)	1684.0 (66.3)	1661.2 (65.4)	1684.0 (66.3)
Seat Cushion Top-to-ROPS Top								
Seat Raised	1186.2 (46.7)	1196.3 (47.1)	1209.0 (47.6)	1221.7 (48.1)	1234.4 (48.6)	1257.3 (49.5)	1234.4 (48.6)	1257.3 (49.5)
Seat Lowered	1186.2 (41.7)	1196.3 (42.1)	1209.0 (42.6)	1221.7 (43.1)	1234.4 (43.6)	1257.3 (44.5)	1234.4 (43.6)	1155.7 (45.5)
Rear Axle Centerline-to-ROPS Top	1795.8 (70.7)	1795.8 (70.7)	1795.8 (70.7)	1795.8 (70.7)	1795.8 (70.7)	1795.8 (70.7)	1795.8 (70.7)	1795.8 (70.7)
Rear Axle Centerline-to-Folded ROPS Top	1351.3 (53.2)	1351.3 (53.2)	1351.3 (53.2)	1351.3 (53.2)	1351.3 (53.2)	1351.3 (53.2)	1351.3 (53.2)	1351.3 (53.2)
Crop Clearance	457.2 (18.0)	401.3 (15.8)	477.5 (18.8)	429.3 (16.9)	477.5 (18.8)	449.6 (17.7)	477.5 (18.8)	449.6 (17.7)
Ground-to-Drawbar Top	381.0 (15.0)	373.4 (14.7)	406.4 (16.0)	396.2 (15.6)	474.4 (18.6)	457.2 (18.0)	474.4 (18.6)	457.2 (18.0)
Drawbar Thickness	33.0 (1.3)	33.0 (1.3)	33.0 (1.3)	33.0 (1.3)	33.0 (1.3)	33.0 (1.3)	33.0 (1.3)	33.0 (1.3)

^aIncludes front weight support.

Continued on next page

OOU1043,000046C -19-28FEB02-1/2

General Specifications

10
10
17

Dimension	Tractor							
	5220		5320		5420		5520	
Straddle Mount	2WD mm (in.)	MFWD mm (in.)	2WD mm (in.)	MFWD mm (in.)	2WD mm (in.)	MFWD mm (in.)	2WD mm (in.)	MFWD mm (in.)
Front Axle Centerline-to-Hood Top	1003.3 (39.5)	911.7 (35.5)	1003.3 (39.5)	901.7 (35.5)	1003.3 (39.5)	901.7 (35.5)	1003.3 (39.5)	901.7 (35.5)
Turning Radius with Brakes	2957 (116.4)	3109 (122.4) 3017.2 ^b (118.8) ^b	2957 (116.4)	3109 (122.4) 3017.2 ^b (118.8) ^b	2957 (116.4)	3109 (122.4) 3017.2 ^b (118.8) ^b	3414 (134.4)	3535 (139.2) 3017.2 ^b (118.8) ^b
Turning Radius without Brakes	3444 (135.6)	3810 (150.0) 3444 ^b (135.6) ^b	3444 (135.6)	3810 (150.0) 3444 ^b (135.6) ^b	3444 (135.6)	3810 (150.0) 3444 ^b (135.6) ^b	3901 (153.6)	4359 (171.6) 3444 ^b (135.6) ^b
Approximate Shipping Weight	1622 kg (3576 lb)	2094 kg (4616 lb)	1747 kg (3851 lb)	2218 kg (4891 lb)	1944 kg (4285 lb)	2414 kg (5323 lb)	2181 kg (4809 lb)	2653 kg (5849 lb)

^bMFWD disengaged.

OUO1043,000046C -19-28FEB02-2/2

General Specifications

10
10
18

**Machine Dimensions (5520 Series Hi-Crop
Straddle Mount)**

Dimension	Tractor
	5520 Hi-Crop
Straddle Mount	MFWD mm (in.)
Wheel Base	2177 (86)
Overall Length Including Draft Links	3848 (151.5)
Overall Width	
Outside Edge of Tires	2375 (93.5)
Rear Axle Flange-to-Rear Axle Flange	1638 (64.5)
Ground-to-ROPS Top	2807 (110.5)
Ground-to-Canopy Top	2972 (117)
Ground-to-Folded ROPS Top	2362 (93)
Rear Axle Centerline-to-ROPS Top	2807 (110.5)
Rear Axle Centerline-to-Folded ROPS Top	2362 (93)
Crop Clearance	749 (29.5)
Ground-to-Drawbar Top	790 (31)
Front Axle Centerline-to-Hood Top	902 (35.5)
Turning Radius with Brakes	4394 (173) 4000.5 ^a (157.5) ^a
Turning Radius without Brakes	4724.4 (186) 4222.75 ^a (166.25) ^a
Approximate Shipping Weight	3241 kg (7145 lb)
^a MFWD disengaged.	

OUO1023,0000366 -19-22FEB02-1/1

Machine Dimensions (Isolated Open Operator Station)

Dimension	Tractor							
	5220		5320		5420		5520	
Isolated Open Operator Station	2WD mm (in.)	MFWD mm (in.)	2WD mm (in.)	MFWD mm (in.)	2WD mm (in.)	MFWD mm (in.)	2WD mm (in.)	MFWD mm (in.)
Wheel Base	2049.8 (80.7)	2049.8 (80.7)	2049.8 (80.7)	2049.8 (80.7)	2176.8 (85.7)	2176.8 (85.7)	2176.8 (85.7)	2176.8 (85.7)
Overall Length Including Draft Links	3622.0 ^a (142.6)	3622.0 ^a (142.6)	3622.0 ^a (142.6)	3622.0 (142.6)	3848.1 ^a (151.5 ^a)	3848.1 ^a (151.5 ^a)	3848.1 ^a (151.5 ^a)	3848.1 ^a (151.5 ^a)
Overall Width								
Outside Edge of Tires	1648.5 (64.9)	1648.5 (64.9)	1795.8 (70.7)	1795.8 (70.7)	1795.8 (70.7)	1795.8 (70.7)	1963.4 (77.3)	1963.4 (77.3)
Rear Axle Flange-to-Rear Axle Flange	1455.4 (57.3)	1455.4 (57.3)	1455.4 (57.3)	1455.4 (57.3)	1455.4 (57.3)	1455.4 (57.3)	1455.4 (57.3)	1455.4 (57.3)
Ground-to-ROPS Top	NA	NA	NA	NA	2667.0 (105.0)	2667.0 (105.0)	2667.0 (105.0)	2667.0 (105.0)
Ground-to-Canopy Top	—	—	—	—	—	—	NA	NA
Ground-to-Folded ROPS Top	NA	NA	NA	NA	2184.4 (86.0)	2184.4 (86.0)	2184.4 (86.0)	2184.4 (86.0)
Hood Top-to-ROPS Top	1346.2 (53.0)	1361.4 (53.6)	1366.5 (53.8)	1389.4 (54.7)	1366.5 (53.8)	1409.7 (55.5)	1366.5 (53.8)	1409.7 (55.5)
Steering Wheel Top-to-ROPS Top	NA	NA	NA	NA	1816.1 (71.5)	1816.1 (71.5)	1816.1 (71.5)	1816.1 (71.5)
Seat Cushion Top-to-ROPS Top								
Seat Raised	NA	NA	NA	NA	1549.4 (61.0)	1549.4 (61.0)	1549.4 (61.0)	1549.4 (61.0)
Seat Lowered	NA	NA	NA	NA	1473.2 (58.0)	1473.2 (58.0)	1473.2 (58.0)	1473.2 (58.0)
Rear Axle Centerline-to-ROPS Top	NA	NA	NA	NA	1981.2 (78.0)	1981.2 (78.0)	1981.2 (78.0)	1981.2 (78.0)
Rear Axle Centerline-to-Folded ROPS Top	NA	NA	NA	NA	1498.6 (59.0)	1498.6 (59.0)	1498.6 (59.0)	1498.6 (59.0)
Crop Clearance	457.2 (18.0)	401.3 (15.8)	477.5 (18.8)	429.3 (16.9)	477.5 (18.8)	449.6 (17.7)	477.5 (18.8)	449.6 (17.7)
Ground-to-Drawbar Top	381.0 (15.0)	373.4 (14.7)	406.4 (16.0)	396.2 (15.6)	474.4 (18.6)	457.2 (18.0)	474.4 (18.6)	457.2 (18.0)
Drawbar Thickness	33.0 (1.3)	33.0 (1.3)	33.0 (1.3)	33.0 (1.3)	33.0 (1.3)	33.0 (1.3)	33.0 (1.3)	33.0 (1.3)

^aIncludes front weight support.

General Specifications

10
10
20

Dimension	Tractor							
	5220		5320		5420		5520	
Isolated Open Operator Station	2WD mm (in.)	MFWD mm (in.)	2WD mm (in.)	MFWD mm (in.)	2WD mm (in.)	MFWD mm (in.)	2WD mm (in.)	MFWD mm (in.)
Front Axle Centerline-to-Hood Top	1003.3 (39.5)	911.7 (35.5)	1003.3 (39.5)	901.7 (35.5)	1003.3 (39.5)	901.7 (35.5)	1003.3 (39.5)	901.7 (35.5)
Turning Radius with Brakes	2957 (116.4)	3109 (122.4) 3017.2 ^b (118.8) ^b	2957 (116.4)	3109 (122.4) 3017.2 ^b (118.8) ^b	2957 (116.4)	3109 (122.4) 3017.2 ^b (118.8) ^b	3414 (134.4)	3535 (139.2) 3017.2 ^b (118.8) ^b
Turning Radius without Brakes	3444 (135.6)	3810 (150.0) 3444 ^b (135.6) ^b	3444 (135.6)	3810 (150.0) 3444 ^b (135.6) ^b	3444 (135.6)	3810 (150.0) 3444 ^b (135.6) ^b	3901 (153.6)	4359 (171.6) 3444 ^b (135.6) ^b
Approximate Shipping Weight	NA	NA	2236 kg (4930 lb)	2799 kg (6170 lb)	NA	NA	NA	2744 kg (6050 lb)

^bMFWD disengaged.

OUO1043.000046E -19-26FEB02-2/2

General Specifications

10
10
21

Machine Dimensions (Cab)

Dimension	Tractor							
	5220		5320		5420		5520	
Cab	2WD mm (in.)	MFWD mm (in.)	2WD mm (in.)	MFWD mm (in.)	2WD mm (in.)	MFWD mm (in.)	2WD mm (in.)	MFWD mm (in.)
Wheel Base	2049.8 (80.7)	2049.8 (80.7)	2049.8 (80.7)	2049.8 (80.7)	2176.8 (85.7)	2176.8 (85.7)	2176.8 (85.7)	2176.8 (85.7)
Overall Length Including Draft Links	3622.0 ^a (142.6)	3622.0 ^a (142.6)	3622.0 ^a (142.6)	3622.0 ^a (142.6)	3848.1 ^a (151.5 ^a)	3848.1 ^a (151.5 ^a)	3848.1 ^a (151.5 ^a)	3848.1 ^a (151.5 ^a)
Overall Width								
(55.8 in.) Tread Setting	1762.8 (64.9 in.)	1762.8 (64.9 in.)	1762.8 (70.7 in.)	1762.8 (70.7 in.)				
(60.4 in.) Tread Setting							1963.4 (77.3 in.)	1963.4 (77.3 in.)
(61.5 in.) Tread Setting					1991.4 (78.4 in.)	1991.4 (78.4 in.)		
Axle Flange-to-Axle Flange	1455.4 (57.3 in)	1455.4 (57.3 in)	1455.4 (57.3 in)	1455.4 (57.3 in)	1455.4 (57.3 in)	1455.4 (57.3 in)	1455.4 (57.3 in)	1455.4 (57.3 in)
Cab Width								
Front Beltline	1193.8 (47.0 in.)	1193.8 (47.0 in.)	1193.8 (47.0 in.)	1193.8 (47.0 in.)	1193.8 (47.0 in.)	1193.8 (47.0 in.)	1193.8 (47.0 in.)	1193.8 (47.0 in.)
Rear Beltline	1562.1 (61.5 in.)	1562.1 (61.5 in.)	1562.1 (61.5 in.)	1562.1 (61.5 in.)	1562.1 (61.5 in.)	1562.1 (61.5 in.)	1562.1 (61.5 in.)	1562.1 (61.5 in.)
Across Fenders	1752.6 (69.0 in.)	1752.6 (69.0 in.)	1752.6 (69.0 in.)	1752.6 (69.0 in.)	1752.6 (69.0 in.)	1752.6 (69.0 in.)	1752.6 (69.0 in.)	1752.6 (69.0 in.)
Below Roof—Front	1186.2 (46.7 in.)	1186.2 (46.7 in.)	1186.2 (46.7 in.)	1186.2 (46.7 in.)	1186.2 (46.7 in.)	1186.2 (46.7 in.)	1186.2 (46.7 in.)	1186.2 (46.7 in.)
Below Roof—Rear	1473.2 (58.0 in.)	1473.2 (58.0 in.)	1473.2 (58.0 in.)	1473.2 (58.0 in.)	1473.2 (58.0 in.)	1473.2 (58.0 in.)	1473.2 (58.0 in.)	1473.2 (58.0 in.)
Cab Roof	1701.8 (67.0 in.)	1701.8 (67.0 in.)	1701.8 (67.0 in.)	1701.8 (67.0 in.)	1701.8 (67.0 in.)	1701.8 (67.0 in.)	1701.8 (67.0 in.)	1701.8 (67.0 in.)
Ground-to-Cab Top	2443.8 (96.2 in.)	2443.8 (96.2 in.)	2466.3 (97.1 in.)	2466.3 (97.1 in.)	2517.1 (99.1 in.)	2517.1 (99.1 in.)	2517.1 (99.1 in.)	2517.1 (99.1 in.)
Rear Axle Centerline-to-Cab Top	1884.0 (72.6 in.)	1884.0 (72.6 in.)	1884.0 (72.6 in.)	1884.0 (72.6 in.)	1884.0 (72.6 in.)	1884.0 (72.6 in.)	1884.0 (72.6 in.)	1884.0 (72.6 in.)
Crop Clearance	457.2 (18.0)	401.3 (15.8)	477.5 (18.8)	429.3 (16.9)	477.5 (18.8)	449.6 (17.7)	477.5 (18.8)	449.6 (17.7)
Ground-to-Drawbar Top	381.0 (15.0)	373.4 (14.7)	406.4 (16.0)	396.2 (15.6)	474.4 (18.6)	457.2 (18.0)	474.4 (18.6)	457.2 (18.0)
Drawbar Thickness	33.0 (1.3)	33.0 (1.3)	33.0 (1.3)	33.0 (1.3)	33.0 (1.3)	33.0 (1.3)	33.0 (1.3)	33.0 (1.3)

^aIncludes front weight support.

Continued on next page

OUO1043.000046D -19-14MAR01-1/2

General Specifications

10
10
22

Dimension	Tractor							
	5220		5320		5420		5520	
Cab	2WD mm (in.)	MFWD mm (in.)	2WD mm (in.)	MFWD mm (in.)	2WD mm (in.)	MFWD mm (in.)	2WD mm (in.)	MFWD mm (in.)
Front Axle Centerline-to-Hood Top	1003.3 (39.5)	911.7 (35.5)	1003.3 (39.5)	901.7 (35.5)	1003.3 (39.5)	901.7 (35.5)	1003.3 (39.5)	901.7 (35.5)
Turning Radius with Brakes	2957 (116.4)	3109 (122.4) 3017.2 ^b (118.8) ^b	2957 (116.4)	3109 (122.4) 3017.2 ^b (118.8) ^b	2957 (116.4)	3109 (122.4) 3017.2 ^b (118.8) ^b	3414 (134.4)	3535 (139.2) 3017.2 ^b (118.8) ^b
Turning Radius without Brakes	3444 (135.6)	3810 (150.0) 3444 ^b (135.6) ^b	3444 (135.6)	3810 (150.0) 3444 ^b (135.6) ^b	3444 (135.6)	3810 (150.0) 3444 ^b (135.6) ^b	3901 (153.6)	4359 (171.6) 3444 ^b (135.6) ^b
Shipping Weight	NA	NA	NA	NA	NA	NA	NA	3243 kg (7150 lb)
Approximate Shipping Weight	NA	NA	NA	NA	NA	2463 kg (5430 lb)	NA	2642 kg (5825 lb)

^bMFWD disengaged.

OUO1043,000046D -19-14MAR01-2/2

Repair Specifications**Section 20—Engine Repair**

NOTE: For all repair specifications use CTM125 for 2.9 L engines or CTM104 for 4.5 L engines.

Item	Measurement	Specification
Engine-to-Clutch Housing Cap Screw	Torque	260 N•m (192 lb-ft)
Engine-to-Clutch Housing Nut	Torque	260 N•m (192 lb-ft)
Engine-to-Front Support Top Cap Screw	Torque	318 N•m (235 lb-ft)
Engine-to-Front Support Lower Cap Screw	Torque	176 N•m (130 lb-ft)
Engine-to-Front Support Nut	Torque	318 N•m (235 lb-ft)
Cooler, Condenser and Receiver-Dryer Line Connection	Torque	17 N•m (150 lb-in.)
Belt Tensioner	Tension	18—22 N•m (13—16 lb-ft)

Section 30—Fuel and Air Repair

NOTE: For all fuel injection nozzle and turbocharger repair use CTM125 for 2.9 L engines or CTM104 for 4.5 L engines

Item	Measurement	Specification
Compressed Air	Pressure	690 kPa (6.9 bar) (100 psi)
Water	Pressure	280 kPa (2.80 bar) (40 psi)
Turbocharger Oil Drain Line	Torque	27 N•m (20 lb-ft)
Turbocharger Oil Inlet Line	Torque	27 N•m (20 lb-ft)
Turbocharger Mounting Cap Screws	Torque	47 N•m (35 lb-ft)

Section 40—Electrical System

For starter repair—Use CTM77

Section 50—Power Train Repair

Item	Measurement	Specification
Clutch Housing		
Engine-to-Clutch Housing Cap Screw	Torque	260 N•m (192 lb-ft)
Engine-to-Clutch Housing Nut	Torque	260 N•m (192 lb-ft)
Clutch Assembly—CollarShift and SyncShuttle™ Transmissions		
PTO Clutch Disk	Thickness	7.6—6.6 mm (0.300—0.260 in.)
Clutch Assembly Mounting Cap Screws	Torque	36 N•m (27 lb-ft)
Traction Clutch Disk	Thickness	10—6 mm (0.395—0.235 in.)
Pressure Plate Minimum Thickness		
PTO Clutch Pressure Plate	Thickness	16.2 mm (0.638 in.)
Traction Clutch Front Pressure Plate	Thickness	26.7 mm (1.051 in.)
Traction Clutch Rear Pressure Plate	Thickness	15.8 mm (0.622 in.)
Clutch Spring Washer	Height	13 mm (0.512 in.)
Clutch Yoke Cap Screw	Torque	65 N•m (48 lb-ft)
Clutch Assembly—PowrReverser™ Transmissions		
Clutch-to-Flywheel Cap Screw	Torque	36 N•m (27 lb-ft)
Single Stage Clutch Pressure Plate	Minimum Thickness	16.2 mm (0.638 in.)
Single Stage Clutch Disk	Minimum Thickness	6.6 mm (0.260 in.)

*SyncShuttle is a trademark of Deere & Company
PowrReverser is a trademark of Deere & Company*

Continued on next page

OUO1089,0000224 -19-26FEB02-2/12

General Specifications

10
10
25

Item	Measurement	Specification
Clutch Release Mechanism Cap Screw	Torque	26 N•m (20 lb-ft)
Traction Clutch Shaft Cap Screw	Torque	65 N•m (48 lb-ft)
Transmission Pump Cap Screw	Torque	26 N•m (20 lb-ft)
PowrReverser™		
Control Valve Cap Screw	Torque	26 N•m (20 lb-ft)
Plug	Torque	19 N•m (14 lb-ft)
Socket Head Screw	Torque	26 N•m (20 lb-ft)
Plug	Torque	29 N•m (21 lb-ft)
Socket Head Screw	Torque	10 N•m (7 lb-ft)
Control Valve Screw	Torque	10 N•m (7 lb-ft)
Cap Screw	Torque	26 N•m (20 lb-ft)
Plate (21)	Minimum Thickness	5.85 mm (0.230 in.)
Disk	Minimum Thickness	2.7 mm (0.106 in.)
Plate (23)	Minimum Thickness	3.85 mm (0.151 in.)
CollarShift and SyncShuttle™ Transmission		
Clutch Housing-to-Transmission Cap Screw	Torque	260 N•m (192 lb-ft)
Transmission Cap Screw	Torque	140 N•m (105 lb-ft)
Park Pawl Cap Screw	Torque	27 N•m (20 lb-ft)
Reverse Idler Shaft	Torque	132 N•m (97 lb-ft)

SyncShuttle is a trademark of Deere & Company
PowrReverser is a trademark of Deere & Company

Continued on next page

OUO1089,0000224 -19-26FEB02-3/12

General Specifications

10
10
26

Item	Measurement	Specification
PowrReverser™ Transmission		
Transmission Cap Screw	Torque	140 N•m (105 lb-ft)
Park Pawl Cap Screw	Torque	27 N•m (20 lb-ft)
Rear PTO Drive Shaft		
Steel Wheel Cap Screw	Torque	175 N•m (130 lb-ft)
Cast Wheel Cap Screw	Torque	225 N•m (166 lb-ft)
Drive Shaft Assembly Cap Screw	Torque	65 N•m (48 lb-ft)
Rear PTO Drive Shaft Assembly Cap Screw	Torque	65 N•m (48 lb-ft)
Differential		
Differential Cap Screw	Torque	58 N•m (43 lb-ft)
Case with Locking Pawl Cap Screw	Torque	95 N•m (70 lb-ft)
Housing Cap Screw	Torque	78 N•m (58 lb-ft)
Differential Drive Shaft Spacer and Shims	Thickness	0.25—0.75 mm (0.010—0.030 in.) nominal
Differential Drive Shaft Nut	Torque	269 N•m (198 lb-ft)
Differential Drive Shaft	Force	53—129 N (12—29 lb-force)
Differential Drive Shaft Quill Cap Screw	Torque	52 N•m (38 lb-ft)
Cone Point Adjustment	Clearance	17.5 ± 0.05 mm (0.688 ± 0.002 in.)
Differential Backlash	Clearance	0.18—0.25 mm (0.007—0.010 in.)
Differential Quill	Angle	30°

General Specifications

10
10
27

Item	Measurement	Specification
Final Drives		
Final Drive Assembly Cap Screw	Torque	100 N•m (74 lb-ft)
Final Drive Housing	Rolling Drag Torque	100 N•m (74 lb-ft) increase above baseline
Bearing Cone	Temperature	150°C (300°F)
Axle Assembly-to-Differential Housing Cap Screws	Torque	100 N•m (74 lb-ft)
HI-Crop Final Drive Housing Cap Screws	Torque	140 N•m (105 lb-ft)
HI-Crop Final Drive-to-Axle Housing Cap Screws	Torque	140 N•m (105 lb-ft)
Mechanical Front Wheel Drive		
MFWD Drop Gearbox Cap Screw	Torque	132 N•m (97 lb-ft)
MFWD Shift Lever Cap Screw	Torque	26 N•m (230 lb-in.)
MFWD Drop Gearbox Cover Cap Screw	Torque	26 N•m (230 lb-in.)
Bearing Cone	Temperature	149°C (300°F)
MFWD Drop Gearbox Nut	Torque	60 N•m (44 lb-ft)
MFWD Drive Shaft Guard Cap Screw	Torque	15 N•m (11 lb-ft)
MFWD Axle-to-Frame Cap Screw	Torque	650 N•m (479 lb-ft)
MFWD Front Wheel Nut	Torque	300 N•m (220 lb-ft)
MFWD Outer Drive Ring Gear Cap Screw	Torque	78 N•m (58 lb-ft)
MFWD Outer Drive Hub Stud	Torque	70 N•m (50 lb-ft)
Planet Pinion Carrier Screw	Torque	21 N•m (18.5 lb-ft)
Planet Pinion Carrier Plug	Torque	80 N•m (59 lb-ft)

Continued on next page

OUO1089,0000224 -19-26FEB02-5/12

General Specifications

10
10
28

Item	Measurement	Specification
MFWD Swivel Housing Cap Screw	Torque	120 N•m (89 lb-ft)
Tie Rod End Nut	Torque	165 N•m (122 lb-ft)
Differential Carrier-to-Axle Housing Cap Screw	Torque	169 N•m (125 lb-ft)
Axle Housing Fill Plug	Torque	70 N•m (50 lb-ft)
Friction Plate	Minimum Thickness	1.30 mm (0.051 in.)
	New Thickness	1.60 mm (0.063 in.)
Drive Plate	Minimum Thickness	1.47 mm (0.058 in.)
	New Thickness	1.53 mm (0.060 in.)
Inner Thrust Plate	Minimum Thickness	2.73 mm (0.107 in.)
	New Thickness	2.83 mm (0.110 in.)
Differential Carrier Assembly Cap Screw	Torque	266 N•m (196 lb-ft)
Circular Bar	Size	25 x 228 mm (0.984 x 8.976 in.)
Pinion Nut	Rotation	105—157 N (24—35 lb-force) pull
Bevel Gear Cap Screw	Torque	78 N•m (58 lb-ft)
Bevel Gear-to-Ring Gear	Distance	0.16—0.21 mm (0.006—0.008 in.)
Differential Ring Nut	Resistance	142—213 N (32—48 lb-force)
End Cap Screw	Torque	266 N•m (196 lb-ft)
Creeper Assembly		
Creeper Assembly Cap Screw	Torque	50 N•m (37 lb-ft)

Section 60—Steering and Brake Repair

Item	Measurement	Specification
Steering		
Steering Column Mounting Cap Screw—Non-Telescoping Column	Torque	71 N•m (52 lb-ft)

Continued on next page

OOU1089.0000224 -19-26FEB02-6/12

General Specifications

10
10
29

Item	Measurement	Specification
Steering Wheel Nut— Non-Telescoping Column	Torque	68 N•m (50 lb-ft)
Steering Column Mounting Cap Screw—Tilt/Telescoping Column	Torque	71 N•m (52 lb-ft)
Steering Wheel Nut— Tilt/Telescoping Column	Torque	68 N•m (50 lb-ft)
Steering Valve Mounting Cap Screw—Telescoping Column	Torque	30 N•m (22 lb-ft)
Steering Valve Cover Cap Screw	Torque	30 N•m (22 lb-ft)
Steering Cylinder Cap Screw— 2WD Axle	Torque	200 N•m (147 lb-ft)
Steering Cylinder Cap Screw— MFWD Axle	Torque	94 N•m (69 lb-ft)
Ball Joint—2WD Axle	Torque	300 N•m (221 lb-ft)
Tie Rod Sleeve Cap Screw—2WD Axle	Torque	90 N•m (66 lb-ft)
Tie Rod End Lock Nut—2WD Axle	Torque	165 N•m (122 lb-ft)
Ball Joint-to-Piston Rod—MFWD Axle	Torque	300 N•m (221 lb-ft)
Ball Joint Nut—MFWD Axle	Torque	120 N•m (89 lb-ft)
Tie Rod End Lock Nut—MFWD Axle	Torque	165 N•m (122 lb-ft)
Brakes		
Brake Valve Mounting Cap Screw	Torque	70 N•m (52 lb-ft)
Brake Valve Inlet Check Valve	Torque	73 N•m (54 lb-ft)
Pressure Equalizing Valve Plug	Torque	37 N•m (27 lb-ft)
Outlet Check Valve Spring Seat Fitting	Torque	92 N•m (68 lb-ft)

Continued on next page

OUO1089.0000224 -19-26FEB02-7/12

General Specifications

10
10
30

Item	Measurement	Specification
Outlet Fitting	Torque	11 N•m (97 lb-in.)
Retractor Spring-to-Piston	Torque	15 N•m (133 lb-in.)
Piston-to-Final Drive Housing Surface	Distance	12.40—12.80 mm (0.488—0.503 in.)

Section 70—Hydraulic Repair

Item	Measurement	Specification
Hydraulic Pump and Filter		
Pick-Up Screen Cover Cap Screw	Torque	23 N•m (17 lb-ft)
Hydraulic Pump Bracket-to-Engine Cap Screw	Torque	41 N•m (30 lb-ft)
Hydraulic Pump Mounting Cap Screw	Torque	50 N•m (37 lb-ft)
Hydraulic Pump Cap Screw and Bolt	Torque	50 N•m (37 lb-ft)
Hydraulic Pump Rear Outlet Fitting	Torque	28 N•m (21 lb-ft)
Hydraulic Pump Front Outlet Fitting	Torque	46 N•m (34 lb-ft)
Drive Gear Retaining Nut	Torque	55 N•m (41 lb-ft)
Pump Bracket Retaining Nut	Torque	50 N•m (37 lb-ft)
Hydraulic Pump Cap Screw	Torque	90 N•m (66 lb-ft)
Hydraulic Pump Body Cap Screw	Torque	68 N•m (50 lb-ft)
Hydraulic Pump Gear Nut	Torque	90 N•m (66 lb-ft)
Hydraulic Oil Filter/Manifold Cap Screw	Torque	70 N•m (52 lb-ft)
Rockshaft		
Draft-Sensing Support Mounting Socket Head Cap Screw	Torque	375 N•m 277 (lb-ft)

Continued on next page

OUO1089,0000224 -19-26FEB02-8/12

General Specifications

10
10
31

Item	Measurement	Specification
Main Relief Valve	Torque	51 N•m (38 lb-ft)
Main Relief Valve Cap	Torque	41 N•m (30 lb-ft)
Surge Relief Valve	Torque	34 N•m (25 lb-ft)
Rate-of-Drop Valve	Torque	50 N•m (37 lb-ft)
Rockshaft Valve-to-Inlet Housing Socket Head Cap Screw	Torque	13.6 N•m (120 lb-in.)
Inlet Housing Mounting Cap Screw	Torque	35 N•m (26 lb-ft)
Rockshaft Control Valve Socket Head Cap Screw	Torque	47 N•m (35 lb-ft)
Inlet Housing Cap Screw	Torque	40 N•m (30 lb-ft)
Hydraulic Line Fitting	Torque	69 N•m (51 lb-ft)
Rockshaft Case Cap Screw	Torque	125 N•m (92 lb-ft)
Hydraulic Pump Outlet Fitting	Torque	69 N•m (51 lb-ft)
Bushing Outer Edge to Edge of Bore	Distance	7 mm (0.283 in.)
Selective Control Valve		
Steel Wheel Cap Screw	Torque	175 N•m (130 lb-ft)
Cast Wheel Cap Screw	Torque	225 N•m (166 lb-ft)
SCV Cap Screw	Torque	12 N•m (106 lb-in.)
SCV Mounting Cap Screw	Torque	70 N•m (52 lb-ft)
Double-Acting Sleeve Coupler	Torque	69 N•m (51 lb-ft)
Cable Mount Cap Screw	Torque	15 N•m (133 lb-in.)
Main Relief Valve	Torque	51 N•m (38 lb-ft)
Spool Detent	Torque	4 N•m (35 lb-in.)
Spool End Cap Socket Head Cap Screw	Torque	7 N•m (62 lb-in.)

Continued on next page

OUO1089.0000224 -19-26FEB02-9/12

General Specifications

10
10
32

Item	Measurement	Specification
Detent Spring Retainer Cap Screw	Torque	27 N•m (239 lb-in.)
Spool Cap Socket Head Cap Screw	Torque	14 N•m (124 lb-in.)
Load Check Cap	Torque	24 N•m (212 lb-in.)
SCV Fitting	Torque	88 N•m (65 lb-ft)
Socket Head Cap Screw	Torque	7 N•m (62 lb-in.)
Hydraulic Mid Mount Control Valve		
Mid Mount Control Valve Cap Screw	Torque	70 N•m (52 lb-ft)
Hydraulic Line Fitting	Torque	69 N•m (51 lb-ft)
Cable Bracket Cap Screw	Torque	15 N•m (11 lb-ft)
Retainer Cap Screw	Torque	27 N•m (239 lb-ft)
Spool Cap Socket Head Cap Screw	Torque	14 N•m (124 lb-in.)
Load Check Cap	Torque	24 N•m (212 lb-in.)

Section 80—Miscellaneous Repair

Item	Measurement	Specification
Front Axle—2WD		
Axle	End Play	0.8 mm (0.030 in.)
2WD Axle Pivot Pin Retainer Cap Screw	Torque	135 N•m (100 lb-ft)
Front Wheel Cap Screw	Torque	175 N•m (129 lb-ft)
Spindle Nut	Torque	415 N•m (306 lb-ft)
Tie Rod End Nut	Torque	165 N•m (122 lb-ft)

Continued on next page

OUO1089,0000224 -19-26FEB02-10/12

General Specifications

10
10
33

Item	Measurement	Specification
Front Wheel—2WD		
Front Wheel Cap Screw	Torque	175 N•m (129 lb-ft)
3-Point Hitch		
Draft Link Support Cap Screw	Torque	200 N•m (148 lb-ft)
Fixed Draft Link Stabilizer Bracket Cap Screw	Torque	350 N•m (258 lb-ft)
Telescoping Draft Link Stabilizer Bracket Cap Screw	Torque	300 N•m (221 lb-ft)
Draw Bar Support Rear Cap Screw	Torque	200 N•m (148 lb-ft)
Draw Bar Support Bottom Cap Screw	Torque	310 N•m (229 lb-ft)
Fenders		
Steel Wheel Cap Screw	Torque	175 N•m (130 lb-ft)
Cast Wheel Cap Screw	Torque	225 N•m (166 lb-ft)

Section 90—Operator Station Repair

Item	Measurement	Specification
Seat and Support		
Seat Support Cap Screws (Straddle Mount)	Torque	125 N•m (92 lb-ft)
ROLL-GARD™		
ROLL-GARD™ Mounting Cap Screw	Torque	675 N•m (500 lb-ft)
Isolated Open Operator Station Rear Mount Cap Screw	Torque	600 N•m (443 lb-ft)

ROLL-GARD is a trademark of Deere & Company

Continued on next page

OUO1089,0000224 -19-26FEB02-11/12

General Specifications

10
10
34

Item	Measurement	Specification
Cab Components		
Window Mounting Hardware	Torque	1.5 N•m (13.5 lb-in.)
Front and Rear Cab Mount Cap Screws	Torque	600 N•m (443 lb-ft)
Control Valve Cap Screw	Torque	26 N•m (20 lb-ft)
Isolated Open Operator Station		
Isolated Open Operator Station Front Mount Cap Screws	Torque	80 N•m (59 lb-ft)
Air Conditioning System		
Receiver-Dryer Lines	Torque	14—20 N•m (10—15 lb-ft)
Condenser Outlet Line	Torque	14—20 N•m (10—15 lb-ft)
Condenser Inlet Line	Torque	33—39 N•m (24—29 lb-ft)
Compressor Suction Line	Torque	35—42 N•m (25—31 lb-ft)
Compressor Discharge Line	Torque	33—39 N•m (24—29 lb-ft)
Clutch Hub Retaining Cap Screw	Torque	14 N•m (10 lb-ft)
Compressor Through Bolt	Torque	26 N•m (19 lb-ft)
Hub-to-Pulley	Clearance	0.35—0.65 mm (0.014—0.026 in.)
Manifold Cap Screw	Torque	26 N•m (19 lb-ft)
Compressor Relief Valve	Torque	12—16 N•m (9—12 lb-ft)

OUO1089,0000224 -19-26FEB02-12/12

Service Recommendations for O-Ring Boss Fittings

Straight Fitting

1. Inspect O-ring boss seat for dirt or defects.
2. Lubricate O-ring with petroleum jelly. Place electrical tape over threads to protect O-ring. Slide O-ring over tape and into O-ring groove of fitting. Remove tape.
3. Tighten fitting to torque value shown on chart.

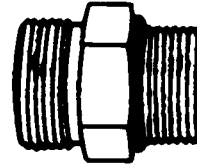

T6243AE -JUN-18OCT88

Continued on next page

04T,90,K66 -19-19MAR96-1/2

10
10
36

Angle Fitting

1. Back-off lock nut (A) and back-up washer (B) completely to head-end (C) of fitting.
2. Turn fitting into threaded boss until back-up washer contacts face of boss.
3. Turn fitting head-end counterclockwise to proper index (maximum of one turn).

NOTE: Do not allow hoses to twist when tightening fittings.

4. Hold fitting head-end with a wrench and tighten locknut and back-up washer to proper torque value.

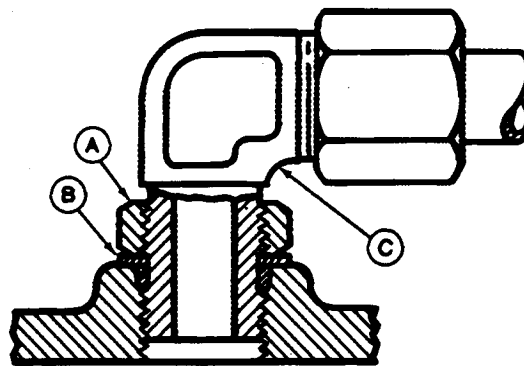

A—Lock Nut
B—Washer
C—Fitting

T6520AB -UN-18OCT88

STRAIGHT FITTING OR SPECIAL NUT TORQUE CHART

Thread Size	N•m	lb-ft
3/8-24 UNF	8	6
7/16-20 UNF	12	9
1/2-20 UNF	16	12
9/16-18 UNF	24	18
3/4-16 UNF	46	34
7/8-14 UNF	62	46
1-1/16-12 UN	102	75
1-3/16-12 UN	122	90
1-5/16-12 UN	142	105
1-5/8-12 UN	190	140
1-7/8-12 UN	217	160

NOTE: Torque tolerance is ± 10%.

04T,90,K66 -19-19MAR96-2/2

Service Recommendations for Flat Face O-Ring Seal Fittings

1. Inspect the fitting sealing surfaces. They must be free of dirt or defects.
2. Inspect the O-ring. It must be free of damage or defects.
3. Lubricate O-rings and install into groove using petroleum jelly to hold in place.
4. Push O-ring into the groove with plenty of petroleum jelly so O-ring is not displaced during assembly.
5. Index angle fittings and tighten by hand pressing joint together to insure O-ring remains in place.
6. Tighten fitting or nut to torque value shown on the chart per dash size stamped on the fitting. Do not allow hoses to twist when tightening fittings.

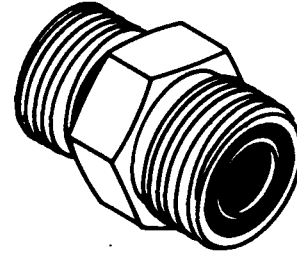

T6243AD -JUN-18OCT88

FLAT FACE O-RING SEAL FITTING TORQUE

Nominal Tube OD		Dash Size	Thread Size	Swivel Nut Torque		Bulkhead Nut Torque	
mm	in.			N•m	lb-ft	N•m	lb-ft
6.35	0.250	-4	9/16-18	16	12	5.0	3.5
9.52	0.375	-6	11/16-16	24	18	9.0	6.5
12.70	0.500	-8	13/16-16	50	37	17.0	12.5
15.88	0.625	-10	1-14	69	51	17.0	12.5
19.05	0.750	-12	1-3/16-12	102	75	17.0	12.5
22.22	0.875	-14	1-3/16-12	102	75	17.0	12.5
25.40	1.000	-16	1-7/16-12	142	105	17.0	12.5
31.75	1.250	-20	1-11/16-12	190	140	17.0	12.5
38.10	1.500	-24	2-12	217	160	17.0	12.5

NOTE: Torque tolerance is +15 -20%.

04T,90,K67 -19-01AUG94-1/1

General Specifications

10
10
38

Metric Cap Screw Torque Values—Grade 7

NOTE: When bolting aluminum parts, tighten to 80% of torque specified in table.

Size	N•m	(lb-ft)
M6	9.5—12.2	(7—9)
M8	20.3—27.1	(15—20)
M10	47.5—54.2	(35—40)
M12	81.4—94.9	(60—70)
M14	128.8—146.4	(95—108)
M16	210.2—240	(155—177)

CED,OUO1085,12 -19-31JUL00-1/1

Metric Bolt and Cap Screw Torque Values

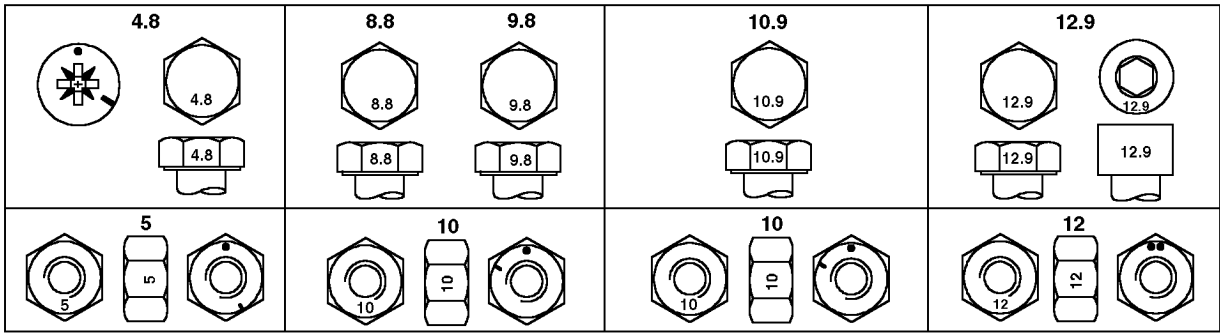

Top, Property Class and Head Markings; Bottom, Property Class and Nut Markings

Size	Class 4.8		Class 8.8 or 9.8		Class 10.9		Class 12.9	
	Lubricated ^a N•m(lb-ft)	Dry ^b N•m(lb-ft)	Lubricated ^a N•m(lb-ft)	Dry ^b N•m(lb-ft)	Lubricated ^a N•m(lb-ft)	Dry ^b N•m(lb-ft)	Lubricated ^a N•m(lb-ft)	Dry ^b N•m(lb-ft)
M6	4.7 (3.5)	6 (4.4)	9 (6.6)	11.5 (8.5)	13 (9.5)	16.5 (12.2)	15.5 (11.5)	19.5 (14.5)
M8	11.5 (8.5)	14.5 (10.7)	22 (16)	28 (20.5)	32 (23.5)	40 (29.5)	37 (27.5)	47 (35)
M10	23 (17)	29 (21)	43 (32)	55 (40)	63 (46)	80 (59)	75 (55)	95 (70)
M12	40 (29.5)	50 (37)	75 (55)	95 (70)	110 (80)	140 (105)	130 (95)	165 (120)
M14	63 (46)	80 (59)	120 (88)	150 (110)	175 (130)	220 (165)	205 (150)	260 (190)
M16	100 (74)	125 (92)	190 (140)	240 (175)	275 (200)	350 (255)	320 (235)	400 (300)
M18	135 (100)	170 (125)	265 (195)	330 (245)	375 (275)	475 (350)	440 (325)	560 (410)
M20	190 (140)	245 (180)	375 (275)	475 (350)	530 (390)	675 (500)	625 (460)	790 (580)
M22	265 (195)	330 (245)	510 (375)	650 (480)	725 (535)	920 (680)	850 (625)	1080 (800)
M24	330 (245)	425 (315)	650 (480)	820 (600)	920 (680)	1150 (850)	1080 (800)	1350 (1000)
M27	490 (360)	625 (460)	950 (700)	1200 (885)	1350 (1000)	1700 (1250)	1580 (1160)	2000 (1475)
M30	660 (490)	850 (625)	1290 (950)	1630 (1200)	1850 (1350)	2300 (1700)	2140 (1580)	2700 (2000)
M33	900 (665)	1150 (850)	1750 (1300)	2200 (1625)	2500 (1850)	3150 (2325)	2900 (2150)	3700 (2730)
M36	1150 (850)	1450 (1075)	2250 (1650)	2850 (2100)	3200 (2350)	4050 (3000)	3750 (2770)	4750 (3500)

^a "Lubricated" means coated with a lubricant such as engine oil, or fasteners with phosphate and oil coatings.

^b "Dry" means plain or zinc plated without any lubrication.

DO NOT use these values if a different torque value or tightening procedure is given for a specific application. Torque values listed are for general use only. Check tightness of fasteners periodically.

Shear bolts are designed to fail under predetermined loads. Always replace shear bolts with identical property class.

Fasteners should be replaced with the same or higher property class. If higher property class fasteners are used, these should only be tightened to the strength of the original.

Make sure fastener threads are clean and that you properly start thread engagement. This will prevent them from failing when tightening.

Tighten plastic insert or crimped steel-type lock nuts to approximately 50 percent of the dry torque shown in the chart, applied to the nut, not to the bolt head. Tighten toothed or serrated-type lock nuts to the full torque value.

TORQ2 -JUN-07SEP99

Unified Inch Bolt and Cap Screw Torque Values

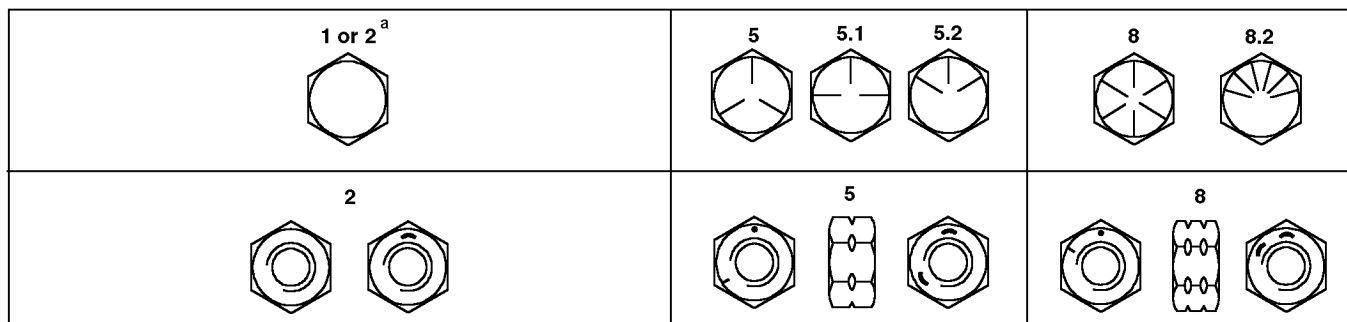

Top, SAE Grade and Head Markings; Bottom, SAE Grade and Nut Markings

TORQ1A -UN-27SEP99

Size	Grade 1 (No Mark)		Grade 2 ^a (No Mark)		Grade 5, 5.1 or 5.2		Grade 8 or 8.2	
	Lubricated ^b N•m(lb-ft)	Dry ^c N•m(lb-ft)	Lubricated ^b N•m(lb-ft)	Dry ^c N•m(lb-ft)	Lubricated ^b N•m(lb-ft)	Dry ^c N•m(lb-ft)	Lubricated ^b N•m(lb-ft)	Dry ^c N•m(lb-ft)
1/4	3.8 (2.8)	4.7 (3.5)	6 (4.4)	7.5 (5.5)	9.5 (7)	12 (9)	13.5 (10)	17 (12.5)
5/16	7.7 (5.7)	9.8 (7.2)	12 (9)	15.5 (11.5)	19.5 (14.5)	25 (18.5)	28 (20.5)	35 (26)
3/8	13.5 (10)	17.5 (13)	22 (16)	27.5 (20)	35 (26)	44 (32.5)	49 (36)	63 (46)
7/16	22 (16)	28 (20.5)	35 (26)	44 (32.5)	56 (41)	70 (52)	80 (59)	100 (74)
1/2	34 (25)	42 (31)	53 (39)	67 (49)	85 (63)	110 (80)	120 (88)	155 (115)
9/16	48 (35.5)	60 (45)	76 (56)	95 (70)	125 (92)	155 (115)	175 (130)	220 (165)
5/8	67 (49)	85 (63)	105 (77)	135 (100)	170 (125)	215 (160)	240 (175)	305 (225)
3/4	120 (88)	150 (110)	190 (140)	240 (175)	300 (220)	380 (280)	425 (315)	540 (400)
7/8	190 (140)	240 (175)	190 (140)	240 (175)	490 (360)	615 (455)	690 (510)	870 (640)
1	285 (210)	360 (265)	285 (210)	360 (265)	730 (540)	920 (680)	1030 (760)	1300 (960)
1-1/8	400 (300)	510 (375)	400 (300)	510 (375)	910 (670)	1150 (850)	1450 (1075)	1850 (1350)
1-1/4	570 (420)	725 (535)	570 (420)	725 (535)	1280 (945)	1630 (1200)	2050 (1500)	2600 (1920)
1-3/8	750 (550)	950 (700)	750 (550)	950 (700)	1700 (1250)	2140 (1580)	2700 (2000)	3400 (2500)
1-1/2	990 (730)	1250 (930)	990 (730)	1250 (930)	2250 (1650)	2850 (2100)	3600 (2650)	4550 (3350)

^a Grade 2 applies for hex cap screws (not hex bolts) up to 6 in. (152 mm) long. Grade 1 applies for hex cap screws over 6 in. (152 mm) long, and for all other types of bolts and screws of any length.

^b "Lubricated" means coated with a lubricant such as engine oil, or fasteners with phosphate and oil coatings.

^c "Dry" means plain or zinc plated without any lubrication.

DO NOT use these values if a different torque value or tightening procedure is given for a specific application. Torque values listed are for general use only. Check tightness of fasteners periodically.

Make sure fastener threads are clean and that you properly start thread engagement. This will prevent them from failing when tightening.

Shear bolts are designed to fail under predetermined loads. Always replace shear bolts with identical grade.

Tighten plastic insert or crimped steel-type lock nuts to approximately 50 percent of the dry torque shown in the chart, applied to the nut, not to the bolt head. Tighten toothed or serrated-type lock nuts to the full torque value.

Fasteners should be replaced with the same or higher grade. If higher grade fasteners are used, these should only be tightened to the strength of the original.

Abbreviations

NOTE: Abbreviations are used in place of some words.

- CTM—Component Technical Manual
- ID—Inside Diameter
- OD—Outside Diameter
- SCV—Selective Control Valve
- MFWD—Mechanical Front-Wheel Drive
- PTO—Power Take-Off
- SMV—Slow Moving Vehicle
- CS—CollarShift
- POW REV—PowrReverser™
- SS—SyncShuttle™
- RCV—Rockshaft Control Valve
- IOOS—Isolated Open Operator Station
- SM—Straddle Mount

AG,OUO1085,13 -19-26FEB02-1/1

Diesel Fuel Specifications

Use either Grade No. 1-D or Grade No. 2-D fuel as defined by ASTM Designation D975 for diesel fuels. Find expected air temperature at time of start on thermometer scale in chart. Correct diesel fuel grade is shown to the right of scale.

NOTE: At altitudes above 1500 m (5000 ft) use grade 1-D for all temperatures.

Fuel sulphur content should be less than 1.0 percent, preferably less than 0.5 percent. Diesel fuel having sulphur content higher than 1.0 percent may cause increased wear on metal engine parts because of acids produced by sulphur during combustion.

IMPORTANT: If fuel sulphur content exceeds 0.7 percent, the engine oil drain interval must be reduced by 50 percent to 125 hours.

Cetane number should be no less than 40 to assure satisfactory starting and overall performance.

Cloud point should be at least -12°C (10°F) below lowest expected air temperature at time of starting. Wax can separate from fuel when temperature decreases to cloud point and may plug filter.

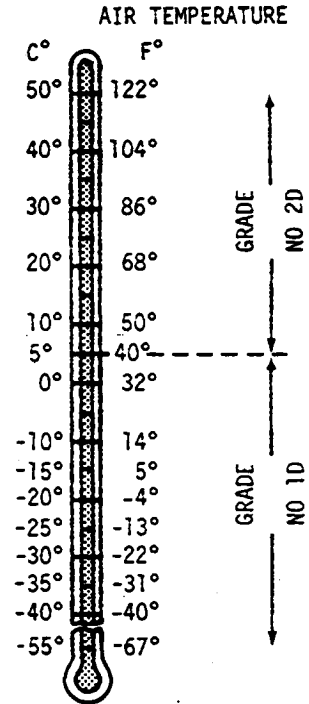

E20380 -19-13MAR89

AG,OUO1085,14 -19-05SEP01-1/1

Storing Fuel

If there is a very slow turnover of fuel in the fuel tank or supply tank, it may be necessary to add a fuel conditioner to prevent water condensation. Contact your John Deere dealer for proper service or maintenance recommendations.

DX,FUEL -19-03MAR93-1/1

Do Not Use Galvanized Containers

IMPORTANT: Diesel fuel stored in galvanized containers reacts with zinc coating on the container to form zinc flakes. If fuel contains water, a zinc gel will also form. The gel and flakes will quickly plug fuel filters and damage fuel injectors and fuel pumps.

DO NOT use a galvanized container to store diesel fuel.

Store fuel in:

- plastic containers.
- aluminum containers.
- specially coated steel containers made for diesel fuel.

DO NOT use brass-coated containers: brass is an alloy of copper and zinc.

M21,FLQ,B1 -19-02AUG85-1/1

Fill Fuel Tank

CAUTION: Handle fuel carefully. Do not refuel the machine while smoking or when near open flame or sparks.

Always stop engine before refueling machine.

Fill fuel tank at end of each day's operation. Fill fuel tank only to bottom of filler neck.

Specification

5220, 5320, and 5420 Fuel Tank (Straddle Mount)—Capacity	68 L (18.0 gal)
5520 (Straddle Mount)—Capacity	83 L (22.0 gal)
5220, 5320, 5420, and 5520 Fuel Tank (Isolated Open Operator Station and Cab Tractors)— Capacity	102 L (27.0 gal)

IMPORTANT: The fuel tank uses a sealed filler cap. If a new filler cap is required, always replace it with a sealed cap.



TSS202 -UN-23AUG88



LV7120 -UN-06JUN01

Straddle Mount



LV7121 -UN-06JUN01

Isolated Open Operator Station and Cab Tractors

AG,QUO1085,15 -19-26FEB02-1/1

Diesel Engine Oil

Use oil viscosity based on the expected air temperature range during the period between oil changes.

The following oil is preferred:

- John Deere PLUS-50®

The following oil is also recommended:

- John Deere TORQ-GARD SUPREME®

Other oils may be used if they meet one or more of the following:

- API Service Classification CH-4
- API Service Classification CG-4
- API Service Classification CF-4
- ACEA Specification E3
- ACEA Specification E2

Multi-viscosity diesel engine oils are preferred.

If diesel fuel with sulfur content greater than 0.5% is used, reduce the service interval by 50%.

Extended service intervals may apply when John Deere preferred engine oils are used. Consult your John Deere dealer for more information.

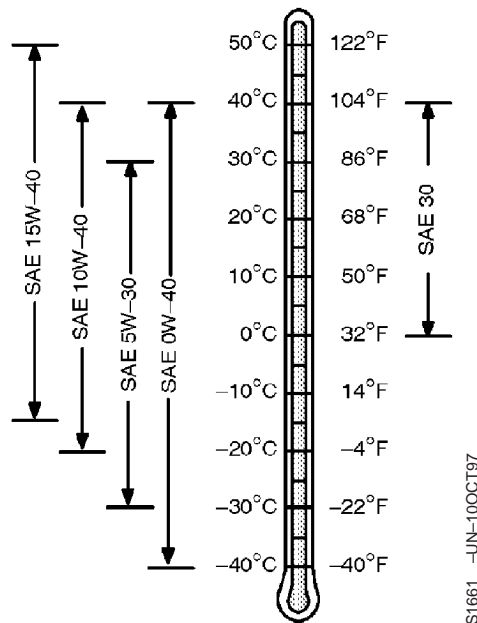

TS1661 -JUN-10OCT97

PLUS-50 is a registered trademark of Deere & Company.
TORQ-GARD SUPREME is a registered trademark of Deere & Company

Diesel Engine Coolant

The engine cooling system is filled to provide year-round protection against corrosion and cylinder liner pitting, and winter freeze protection to -37°C (-34°F).

The following engine coolant is preferred for service:

- John Deere COOL-GARD® Prediluted Coolant

The following engine coolant is also recommended:

- John Deere COOL-GARD® Coolant Concentrate in a 40 to 60% mixture of concentrate with quality water.

Other low silicate ethylene glycol base coolants for heavy-duty engines may be used if they meet one of the following specifications:

- ASTM D5345 (prediluted coolant)
- ASTM D4985 (coolant concentrate) in a 40 to 60% mixture of concentrate with quality water

Coolants meeting these specifications require use of supplemental coolant additives, formulated for heavy-duty diesel engines, for protection against corrosion and cylinder liner erosion and pitting.

A 50% mixture of ethylene glycol engine coolant in water provides freeze protection to -37°C (-34°F). If

protection at lower temperatures is required, consult your John Deere dealer for recommendations.

Water quality is important to the performance of the cooling system. Distilled, deionized, or demineralized water is recommended for mixing with ethylene glycol base engine coolant concentrate.

IMPORTANT: Do not use cooling system sealing additives or antifreeze that contains sealing additives.

Coolant Drain Intervals

Drain the factory fill engine coolant, flush the cooling system, and refill with new coolant after the first 3 years or 3000 hours of operation. Subsequent drain intervals are determined by the coolant used for service. At each interval, drain the coolant, flush the cooling system, and refill with new coolant.

When John Deere COOL-GARD is used, the drain interval may be extended to 5 years or 5000 hours of operation, provided that the coolant is tested annually AND additives are replenished, as needed, by adding a supplemental coolant additive.

If COOL-GARD is not used, the drain interval is reduced to 2 years or 2000 hours of operation.

COOL-GARD is a trademark of Deere & Company

DX.COOL3 -19-05FEB99-1/1

Liquid Coolant Conditioner

John Deere Liquid Coolant Conditioner (part number RE23182) is recommended for wet-sleeve diesel engines not having a coolant filter option. Other conditioners may be used if they contain non-chromate inhibitors.



CAUTION: Coolant conditioner contains alkali. AVOID contact with eyes. Avoid prolonged or repeated contact with skin. DO NOT take internally. In case of contact, immediately wash skin with soap and water. For eyes, flush with large amounts of water for at least 15 minutes. Call physician. Keep out of reach of children.

IMPORTANT: DO NOT use liquid conditioner if engine is equipped with a John Deere Coolant Filter Conditioner, since the correct inhibitors are already contained inside the filter. If both are used, a gel-type deposit is created which could inhibit heat transfer and block coolant flow. John Deere Liquid Coolant Conditioner does not protect against freezing.

Add 30 mL of John Deere Liquid Coolant Conditioner for every liter of coolant added (4 fluid ounces per gallon). When servicing cooling system at 750 hours, only 1/2 of the original charge is required.



RG-4690 -UN-14DEC88

OUC1089,0000356 -19-04JUN01-1/1

Transmission and Hydraulic Oil

Use oil viscosity based on the expected air temperature range during the period between oil changes.

The following oils are preferred:

- John Deere HY-GARDHY-GARD®
- John Deere Low Viscosity HY-GARDHY-GARD®

Other oils may be used if they meet one of the following:

- John Deere Standard JDM J20C
- John Deere Standard JDM J20D

Use the following oil when a biodegradable fluid is required:

- John Deere BIO-HY-GARD™¹

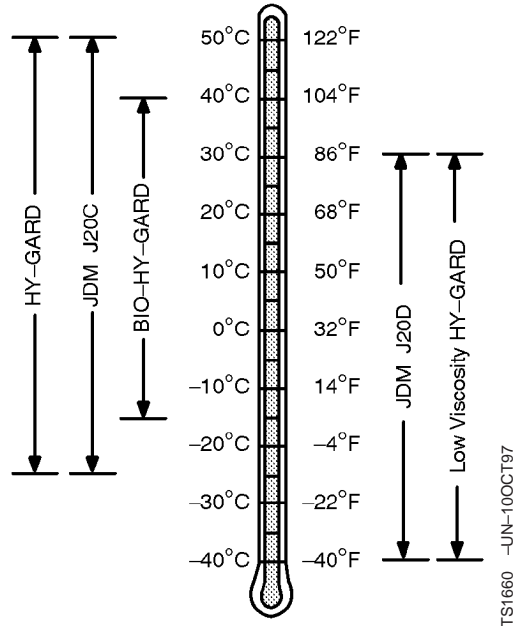

*HY-GARD is a registered trademark of Deere & Company.
BIO-HY-GARD is a trademark of Deere & Company.*

¹*BIO-HY-GARD meets or exceeds the minimum biodegradability of 80% within 21 days according to CEC-L-33-T-82 test method. BIO-HY-GARD should not be mixed with mineral oils because this reduces the biodegradability and makes proper oil recycling impossible.*

DX,ANTI -19-10OCT97-1/1

MFWD Gear Oil

Use oil viscosity based on the expected air temperature range during the period between oil changes.

John Deere GL-5 Gear Lubricant is recommended.

Other oils may be used if they meet one or more of the following:

- API Service Classification GL-5
- Military Specification MIL-L-2105D
- Military Specification MIL-L-2105C
- Military Specification MIL-L-2105B

Oils meeting Military Specification MIL-L-10324A may be used as arctic oils.

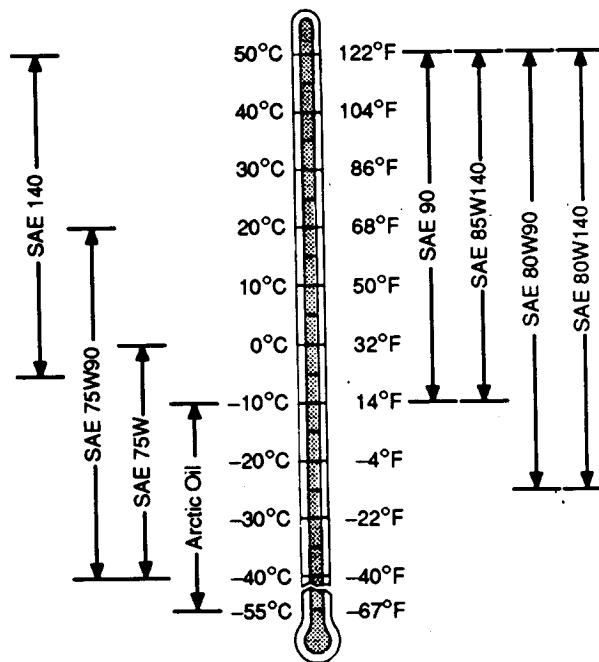

TS245 -19-28NOV90

LV,1020HA,A3 -19-19JAN95-1/1

Grease (Specific Application)

Lithium Grease with Molybdenum Disulphide is recommended for use on internal components of transmission.

TY6333 or TY6347 John Deere Moly High Temperature EP Grease is recommended for use on the traction clutch and PTO clutch splines.

LV,1020HA,A4 -19-27JUN94-1/1

Grease

Use grease based on NLGI consistency numbers and the expected air temperature range during the service interval.

The following greases are preferred:

- John Deere SD POLYUREA GREASE

The following greases are also recommended:

- John Deere HD MOLY GREASE
- John Deere HD LITHIUM COMPLEX GREASE
- John Deere HD WATER RESISTANT GREASE
- John Deere GREASE-GARD

Other greases may be used if they meet the following:

- NLGI Performance Classification GC-LB

IMPORTANT: Some types of grease thickener are not compatible with others. Consult your grease supplier before mixing different types of grease.

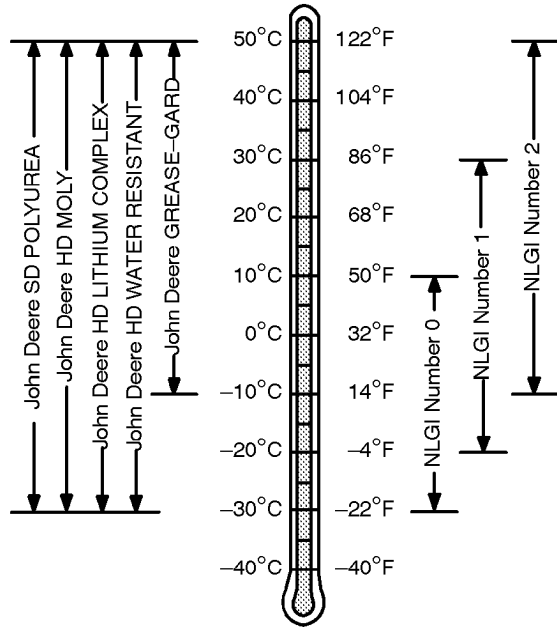

TS1667 -UN-30JUN99

DX.GRE1 -19-24JAN00-1/1

Alternative and Synthetic Lubricants

Conditions in certain geographical areas may require lubricant recommendations different from those printed in this manual.

Some John Deere brand coolants and lubricants may not be available in your location.

Consult your John Deere dealer to obtain information and recommendations.

Synthetic lubricants may be used if they meet the performance requirements as shown in this manual.

The temperature limits and service intervals shown in this manual apply to both conventional and synthetic oils.

Re-refined base stock products may be used if the finished lubricant meets the performance requirements.

DX,ALTER -19-18MAR96-1/1

Lubricant Storage

Your equipment can operate at top efficiency only when clean lubricants are used.

Use clean containers to handle all lubricants.

Whenever possible, store lubricants and containers in an area protected from dust, moisture, and other contamination. Store containers on their side to avoid water and dirt accumulation.

Make certain that all containers are properly marked to identify their contents.

Properly dispose of all old containers and any residual lubricant they may contain.

DX,LUBST -19-18MAR96-1/1

Serial Numbers

When working on machines or components that are covered by warranty, it is **IMPORTANT** that you include the machine's Product Identification Number and the component serial number on the warranty claim form.

The location of component serial number plates are shown below.

MX,1025FT,A4 -19-15JAN91-1/1

Product Identification Number Location

The machine's product identification number plate (A) is located on the right-hand side of the front support.

A—Product Identification Number Plate



LV093 -UN-21NOV91

AG,OUO1085,16 -19-31JUL00-1/1

Engine Serial Number Location

The engine serial number plate (A) is located on the right-hand side of the engine block, between the starter and the hydraulic pump.

A—Engine Serial Number Plate

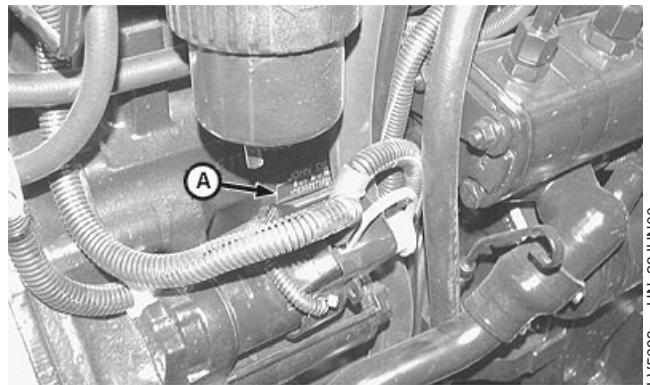

LV5093 -UN-23JUN00

AG,OUO1085,17 -19-31JUL00-1/1

Fuel Injection Pump Serial Number Location

The fuel injection pump serial number plate (A) is located on the side of the pump.

A—Fuel Injection Pump Serial Number Plate

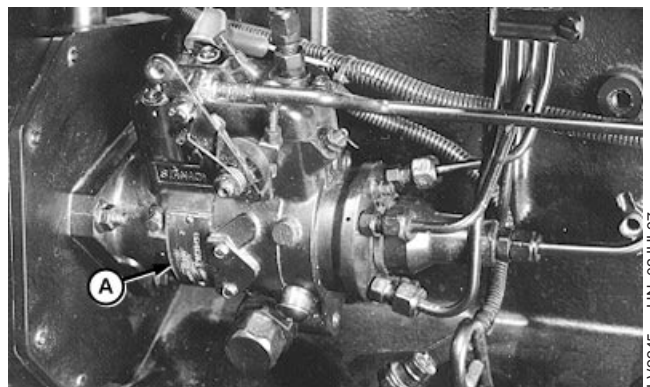

LV2245 -UN-02JUL97

AG,OUO1085,18 -19-31JUL00-1/1

10
25
2

Alternator Serial Number Location

The alternator serial number plate (A) is located on the side of the housing.

A—Alternator Serial Number Plate



LV097 -UN-21NOV91

AG.OUO1085,19 -19-31JUL00-1/1

Power Steering Valve Serial Number Location

The power steering valve serial number plate (A) is located on the bottom of the valve.

A—Power Steering Valve Serial Number Plate



LV098 -UN-21NOV91

AG.OUO1032,2849 -19-18JAN00-1/1

Starter Serial Number Location

The starter serial number plate (A) is located on the side of the starter housing.

A—Starter Serial Number Plate

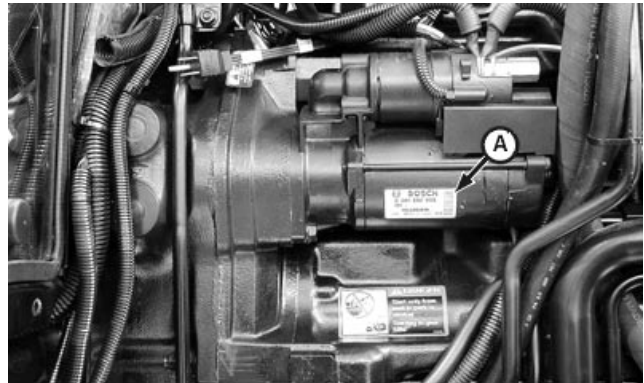

LV5286 -UN-13SEP00

AG.OUO1085,20 -19-31JUL00-1/1

Transmission Serial Number Location

The transmission (drive train) serial number (A) is located at the rear of the machine on the bottom left-hand corner of the differential housing.

A—Transmission Serial Number

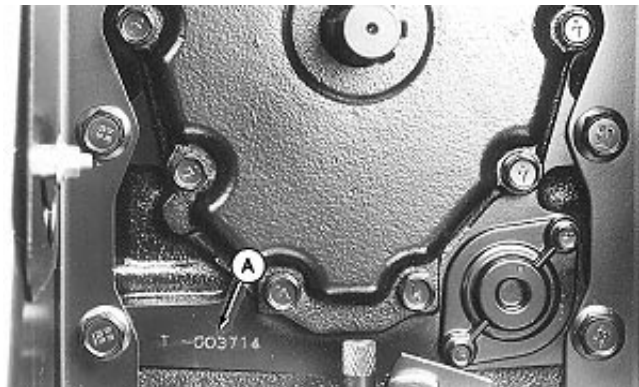

LV629 -UN-17JUN94

AG.OUO1085,21 -19-31JUL00-1/1

Front Axle (2WD) Serial Number Location

The 2WD front axle serial number plate (A) is located on the rear right-hand side of the axle.

A—Front Axle Serial Number Plate

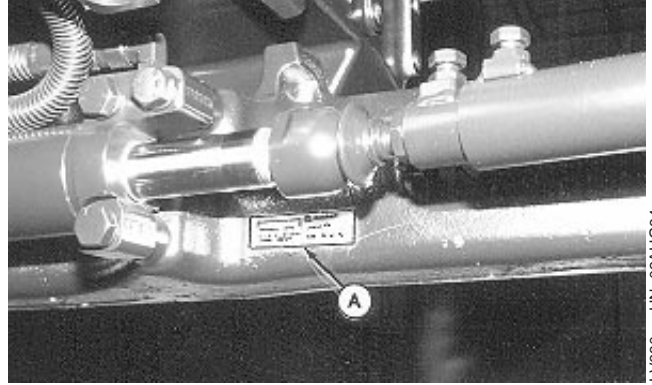

LV630 -UN-02AUG94

AG,OUO1085,22 -19-31JUL00-1/1

Mechanical Front Wheel Drive (MFWD) Serial Number Location

The MFWD serial number plate (A) is located on the rear side of the right-hand axle housing.

A—MFWD Serial Number Plate

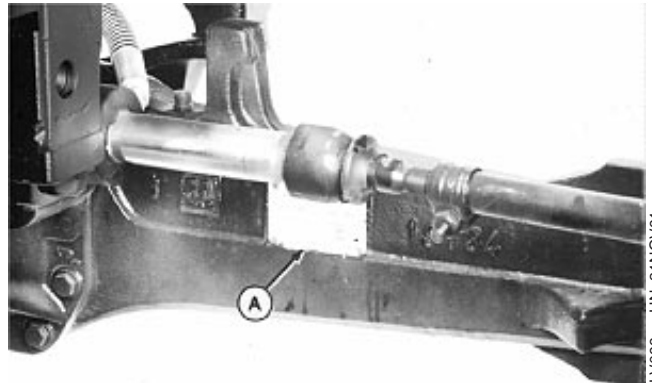

LV099 -UN-21NOV91

AG,OUO1085,23 -19-31JUL00-1/1

Air Conditioning Compressor Serial Number Location

The air conditioning compressor serial number plate (A) is located on the rear of the housing.

A—Air Conditioning Compressor Serial Number Plate

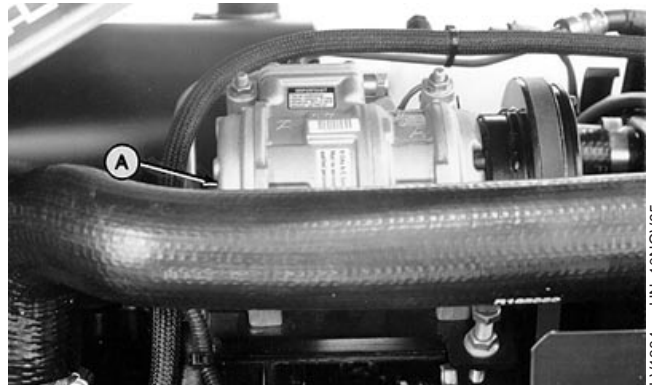

LV1384 -UN-10NOV95

AG,OUO1085,24 -19-31JUL00-1/1

Serial Number Locations

10
25
4

Features and Accessories

The information covered in this group pertains to the features of the machines covered in this Technical Manual. It can be used in addition to the normal advertising literature or may help in determining which specific feature requires service. A list of all the available accessories and kits is also included.

LV,1030HA,A2 -19-05SEP01-1/1

Standard Features—Straddle Mount and Isolated Open Operator Station Tractors

- John Deere 320 Series Engine
 - 5220 PE3029DLV53 39 kw (53 hp)
 - 5320 PE3029TLV52 46.9 kw (63 hp)
 - 3-cylinder diesel engine
 - Wet sleeved
 - Direct injection
 - Key switch controlled fuel shut-off
 - 5220 is naturally aspirated
 - 5320 is turbocharged
- John Deere 350 Series Engine
 - 5420 PE4045DLV51 57.4 kw (77 hp)
 - 5520 PE4045TLV51 66 kw (89 hp)
 - 4-cylinder diesel engine
 - Wet sleeved
 - Direct injection
 - Key switch controlled fuel shut-off
 - 5420 is naturally aspirated
 - 5520 is turbocharged
- CollarShift Transmission
 - Nine speeds forward, three reverse
 - Inboard planetary final drives
 - Differential lock
- Heavy-Duty 2WD Front Axle
- Dual Clutch
 - Provides independent PTO
 - Stops tractor without disengaging PTO
- PTO
 - Rear, 540 rpm
 - Fully independent clutch
- Hydrostatic Power Steering
 - Power is supplied by a tandem gear hydraulic pump mounted to the engine
- Hydraulic Brakes
 - Wet disc
 - Individually hydraulic controlled
 - Self-adjusting and Self-equalizing
- Open-Center Hydraulic System
 - Tandem gear hydraulic pumps
 - Pumps are driven directly off engine timing gears

The rear pump supplies oil to the power steering, brake valve and lubricates top shaft of the transmission.



Straddle Mount Tractor

LV6081 –UN–15JAN01



Isolated Open Operator Station

LV6079 –UN–15JAN01

Features and Accessories

The front pump supplies oil to the rockshaft and the selective control valves, if equipped.

10
30
3

OUO1023,0000319 -19-26FEB02-2/2

Standard Features—Cab Tractor

- John Deere 320 Series Engine
 - 5220 PE3029DLV53 39 kw (53 hp)
 - 5320 PE3029TLV52 46.9 kw (63 hp)
 - 3-cylinder diesel engine
 - Wet sleeved
 - Direct injection
 - Key switch controlled fuel shut-off
 - 5220 is naturally aspirated
 - 5320 is turbocharged
- John Deere 350 Series Engine
 - 5420 PE4045DLV51 57.4 kw (77 hp)
 - 5520 PE4045TLV51 66 kw (89 hp)
 - 4-cylinder diesel engine
 - Wet sleeved
 - Direct injection
 - Key switch controlled fuel shut-off
 - 5420 is naturally aspirated
 - 5520 is turbocharged
- Heavy-Duty 2WD Front Axle
- CollarShift Transmission
 - Nine speeds forward, three reverse
 - Inboard planetary final drives
 - Differential lock
- Dual Clutch
 - Provides independent PTO
 - Stops tractor without disengaging PTO
- PTO
 - Rear, 540 rpm
 - Fully independent clutch
- Hydrostatic Power Steering
 - Tilt and telescoping steering wheel
 - Power is supplied by a tandem gear hydraulic pump mounted to the engine
- Hydraulic Brakes
 - Wet disc
 - Individually hydraulic controlled
 - Self-adjusting and Self-equalizing
- Open-Center Hydraulic System
 - Tandem gear hydraulic pumps
 - Pumps are driven directly off engine timing gears

The rear pump supplies oil to the power steering, brake valve and lubricates top shaft of the transmission.



Cab Tractor

LV6080 –UN–15JAN01

The front pump supplies oil to the rockshaft and the selective control valves, if equipped.

OUO1089,00002BD -19-19SEP01-2/2

Standard Features—5520 Hi-Crop Straddle Mount Tractors

- John Deere 350 Series Engine
 - 5520 PE4045TLV51 66 kw (89 hp)
 - 4-cylinder turbocharged diesel engine
 - Wet sleeved
 - Direct injection
 - Key switch controlled fuel shut-off
- CollarShift Transmission
 - Nine speeds forward, three reverse
 - Drop axle final drive gear case
 - Differential lock
- Mechanical front wheel drive (MFWD)
- Dual Clutch
 - Provides independent PTO
 - Stops tractor without disengaging PTO
- PTO
 - Rear, 540 rpm
 - Fully independent clutch
- Hydrostatic Power Steering
 - Power is supplied by a tandem gear hydraulic pump mounted to the engine
- Hydraulic Brakes
 - Wet disc
 - Individually hydraulic controlled
 - Self-adjusting and Self-equalizing
- Open-Center Hydraulic System
 - Tandem gear hydraulic pumps
 - Pumps are driven directly off engine timing gears

The rear pump supplies oil to the power steering, brake valve and lubricates top shaft of the transmission.

The front pump supplies oil to the rockshaft and the selective control valves, if equipped.



5520 Hi-Crop Straddle Mount

LV7197 -UN-08MAR02

OUO1023,0000367 -19-22FEB02-1/1

Standard Features—5220 through 5520

- Heavy-Duty 2WD Adjustable Front Axle
- Three Point Hitch
 - Category II, convertible to category I
 - Position and draft control levers
- PTO Warning System
 - Warning horn sounds for 8—10 seconds when operator leaves seat with PTO engaged. Engine and PTO continue to run.
- Two-Post Foldable ROPS with Seat Belt
 - Protects operator in the event of a tip-over



LV6498 -UN-14MAR01

OJ01089,00002BE -19-09MAR01-1/1

Factory Installed Optional Equipment (5220—5520)

- Mechanical Front Wheel Drive (MFWD) Axle
 - Center line design
 - Limited slip differential
 - High pivot point for better ground clearance and axle oscillation
- SyncShuttle™ Transmission with Shifttable 540/540E PTO
- SyncShuttle™ Transmission
 - Nine speeds forward, three reverse
 - Synchronized forward to reverse shift
- PowrReverser™ Transmission
 - 12 speeds forward, 12 reverse
 - Hydraulic forward to reverse shift
- Mid-Mount Control Valve
 - One lever “joystick” control
 - Float and regenerative spool valves
- Single (third) selective control valve (Straddle mount tractors only)
- Dual selective control valve
- Triple selective control valve
 - lever operation for each valve
- Cold Weather Package
 - Engine coolant heater
 - Heavy duty air intake heater



LV1894 –UN–09JUN97



LV7380

LV7380 –UN–19JUL01



LV6080 –UN–15JAN01

Field Installed Optional Kits and Accessories—5220 through 5520

- Mid-mount control valve
 - One lever “joystick” control
 - Float and regenerative spool valves
- Single (third) selective control valve (Straddle mount tractors only)
- Dual selective control valve
- Triple selective control valve
 - lever operation for each valve
- Creeper gear kit
- Front drive shaft coupler
- Horizontal rear exhaust extension
- Single horn
- Front weight bracket and weights
- FOPS canopy
- Standard canopy
- Deluxe canopy
- Narrow front axle kit (2WD only)
- Interchangeable, category II-to-category I hitch balls
- Work lights for tractors without fender mounted lights
- Larger tool box
- Available for factory installed cab
 - Right-hand exterior mirror
 - Rear wiper and windshield washer
 - AM and FM radio with speakers and antenna
 - Rotating beacon light
- Cold Weather Package
 - Engine coolant heater
 - Heavy duty air intake heater

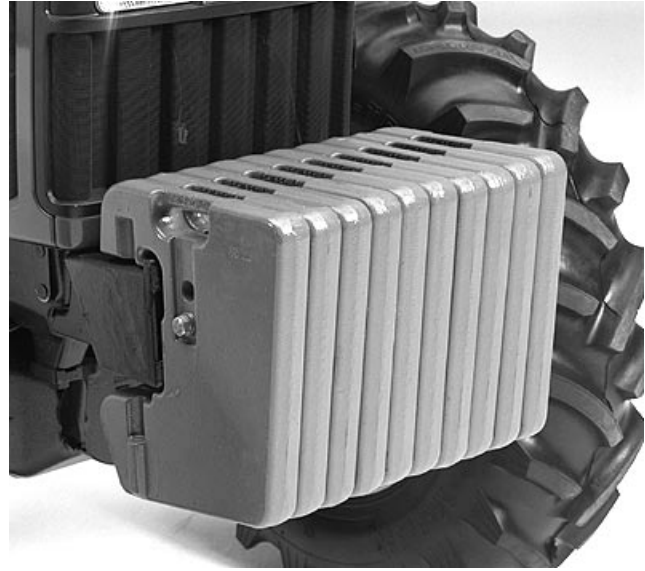

LV1896 –UN-09JUN97

OUC1089,0000225 –19-22FEB02-1/1

<https://www.ebooklibonline.com>

Hello dear friend!

Thank you very much for reading.

Enter the link into your browser.

The full manual is available for immediate download.

<https://www.ebooklibonline.com>

Section 20 Engine Repair

Contents

Page

Group 05—Engine

Service Equipment and Tools	20-05-1
Specifications	20-05-2
John Deere Engine Repair—Use CTM104 or CTM125.	20-05-2
Remove Engine—Tractors Without Cab	20-05-3
Install Engine—Tractors Without Cab	20-05-9
Remove Engine—Tractors With Cab.	20-05-15
Install Engine—Tractors With Cab.	20-05-26

Group 10—Cooling System

Specifications	20-10-1
Engine Water Pump Repair—Use CTM104 or CTM125.	20-10-1
Remove and Inspect Radiator.	20-10-2
Install Radiator	20-10-5
Replace Thermostat	20-10-8
Inspect and Replace Belt Tensioner— Models 5420 and 5520	20-10-10

Service Equipment and Tools

NOTE: Order tools according to information given in the U.S. SERVICEGARD™ Catalog or from the European Microfiche Tool Catalog (MTC). Some tools may be available from a local supplier.

SERVICEGARD is a trademark of Deere & Company

OUO1089,0000304 -19-16APR01-1/4

Lifting Bracket JDG19

Used to remove and install engine.

OUO1089,0000304 -19-16APR01-2/4

Lifting Bracket JT01748

Used to remove and install engine.

OUO1089,0000304 -19-16APR01-3/4

Flywheel Turning Tool JDE83

Used to align traction clutch and shaft.

OUO1089,0000304 -19-16APR01-4/4

Specifications

Item	Measurement	Specification
Engine-to-Clutch Housing Cap Screw	Torque	260 N•m (192 lb-ft)
Engine-to-Clutch Housing Nut	Torque	260 N•m (192 lb-ft)
Engine-to-Front Support Top Cap Screw	Torque	318 N•m (235 lb-ft)
Engine-to-Front Support Lower Cap Screw	Torque	176 N•m (130 lb-ft)
Engine-to-Front Support Nut	Torque	318 N•m (235 lb-ft)
Cooler, Condenser and Receiver-Dryer Line Connection	Torque	17 N•m (150 lb-in.)

OUO1089,0000312 -19-17APR01-1/1

John Deere Engine Repair—Use CTM104 or CTM125

For complete repair information the component technical manual (CTM) is also required. Use the component technical manual in conjunction with this machine manual.

- 3 cylinder 2.9 L engines—Use CTM125
- 4 cylinder 4.5 L engines—Use CTM104



TS225 -JUN-17JAN89

AG,OUO1085,30 -19-02AUG00-1/1

Remove Engine—Tractors Without Cab

NOTE: 4-cylinder engine shown. 3-cylinder engines are similar.

1. Remove hood and side grille panels from tractor.
2. Remove battery. (See Remove and Install Battery—Straddle Mount and Isolated Open Operator Station in Section 40, Group 05.)

⚠ CAUTION: Explosive release of fluids from pressurized cooling system can cause serious burns. Shut off engine. Remove filler cap only when cool enough to touch with bare hands. Slowly loosen cap to first stop to relieve pressure before removing completely.

3. Remove radiator. (See Remove and Inspect Radiator in Group 10.)
4. Straddle mount tractors: Remove fuel filter/primer pump. (See Remove and Install Fuel Filter/Primer Pump Assembly in Section 30, Group 05.)
5. Straddle mount tractors equipped with 4-cylinder engine: Remove four cap screws (A), oil filter and bracket (B) and oil tubes (C and D) from engine oil cooler manifold.
6. Remove MFWD drive shaft, if equipped. (See Remove, Inspect and Install MFWD Drive Shaft in Section 50, Group 35.)

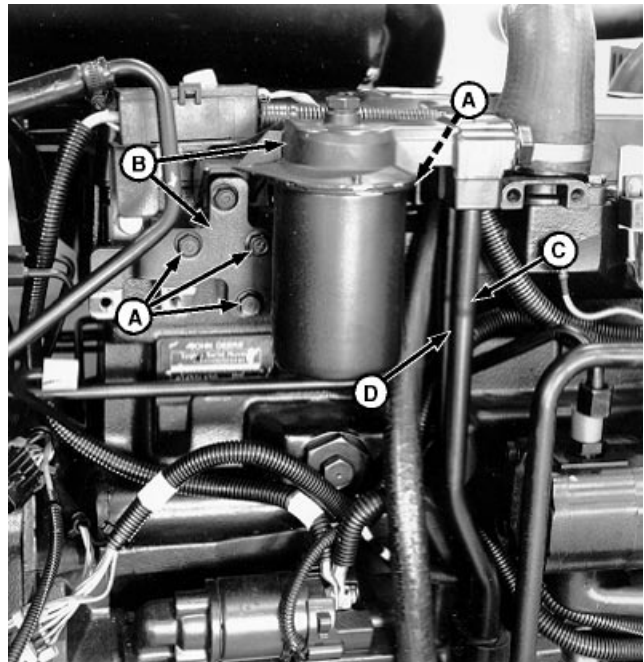

A—Cap Screws (4 used)
 B—Oil Filter and Bracket
 C—Oil Tube
 D—Oil Tube

TSS281 -JUN-23AUG88

LV2332 -JUN-16DEC97

20
05
3

Continued on next page

OUO1089,00002FD -19-28FEB02-1/8

7. Drain hydraulic fluid.

NOTE: Close all openings using caps and plugs.

Tag or label hydraulic steering and oil cooler lines before disconnecting to aid during installation.

8. Isolated open operator Station tractors: Disconnect hydraulic steering line (B) from behind fuel filter/primer pump. Move hydraulic hose leading to steering valve away from engine.

9. Straddle mount tractors: Remove dash panels, disconnect all hydraulic lines from steering valve and remove hydraulic steering line (B) from tractor. Close all openings using caps and plugs. Tag or label steering lines before disconnecting to aid during installation.

10. Disconnect hydraulic inlet line (A) and suction line (C) from pump. Close all openings using caps and plugs.

11. Loosen hydraulic line retaining clamp under right-side floor and step plate. Remove hydraulic inlet line (A) and suction line (C) from tractor.

12. Remove muffler and exhaust pipe from engine.

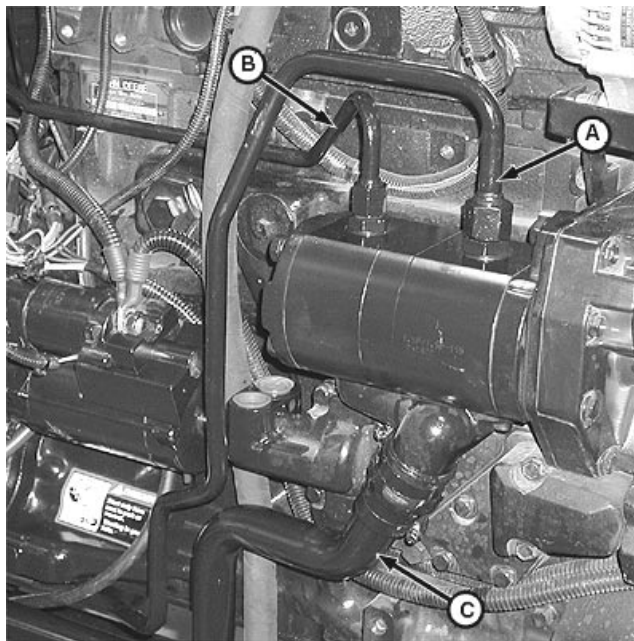

LV6741 -UN-18APR01

A—Hydraulic Inlet Line
B—Hydraulic Steering Line
C—Suction Line

Continued on next page

OOU1089,00002FD -19-28FEB02-2/8

NOTE: Cut all tie straps as necessary.

13. Disconnect two main harness wiring connectors (A and B).
14. Disconnect fuel return hose (C). Close all openings using caps and plugs.
15. Disconnect red wire leads from right-side post (D) of fuse link junction box.

- A—Wiring Connector
- B—Wiring Connector
- C—Fuel Return Hose
- D—Right-Side Post (at Fuse Link Junction Block)

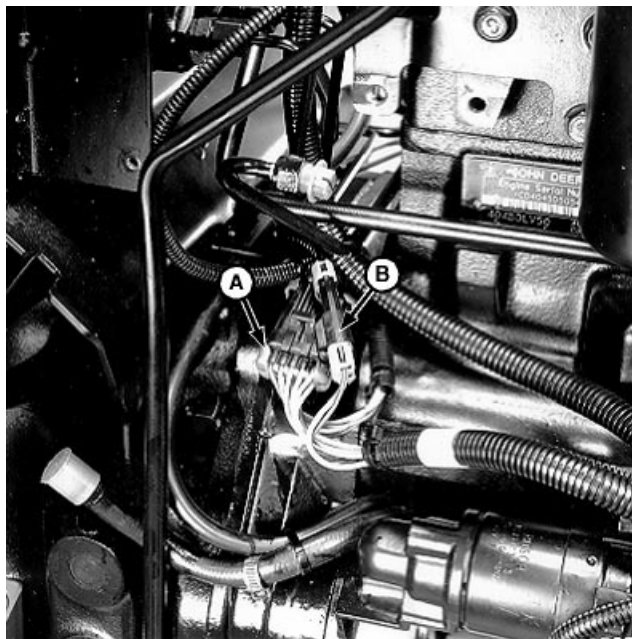

LV2290 -UN-16DEC97

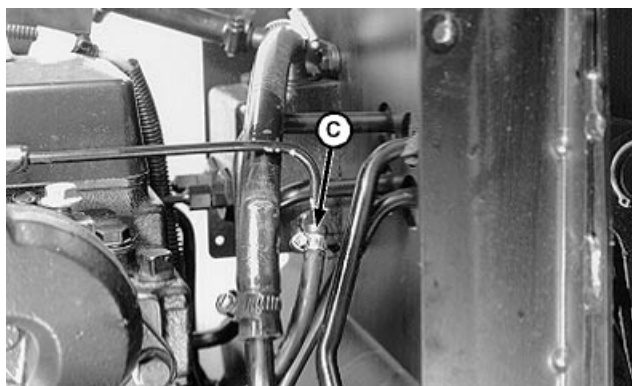

LV2291 -UN-18DEC97

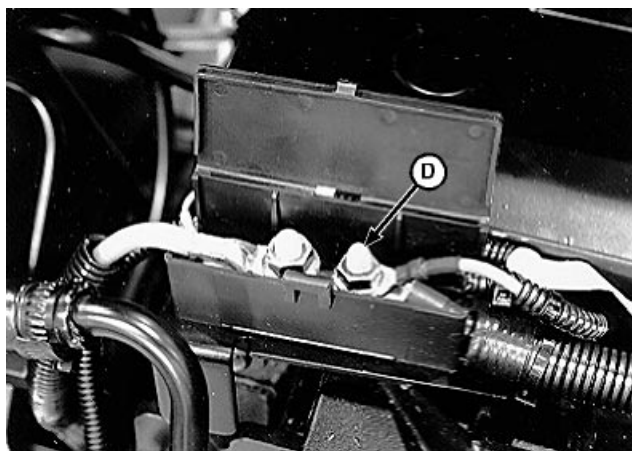

LV2293 -UN-16DEC97

Continued on next page

OOU1089,00002FD -19-28FEB02-3/8



Suggest:

If the above button click is invalid.

Please download this document first, and then click the above link to download the complete manual.

Thank you so much for reading

16. Remove throttle control rod (G).
17. Remove clamps (C and D) and loosen clamp (H).

NOTE: Close all openings using caps and plugs.

Tag or label hydraulic steering and oil cooler lines before disconnecting to aid during installation.

18. Disconnect and remove hydraulic steering lines (A and B). Close all openings using caps and plugs. Tag or label hydraulic steering lines before disconnecting to aid during installation.
19. Disconnect and remove hydraulic oil cooler line (E). Disconnect hydraulic oil cooler line (F). Close all openings using caps and plugs. Tag or label oil cooler lines before disconnecting to aid during installation.

- A—Hydraulic Steering Line
- B—Hydraulic Steering Line
- C—Clamp
- D—Clamp
- E—Hydraulic Oil Cooler Line
- F—Hydraulic Oil Cooler Line
- G—Throttle Control Rod
- H—Clamp

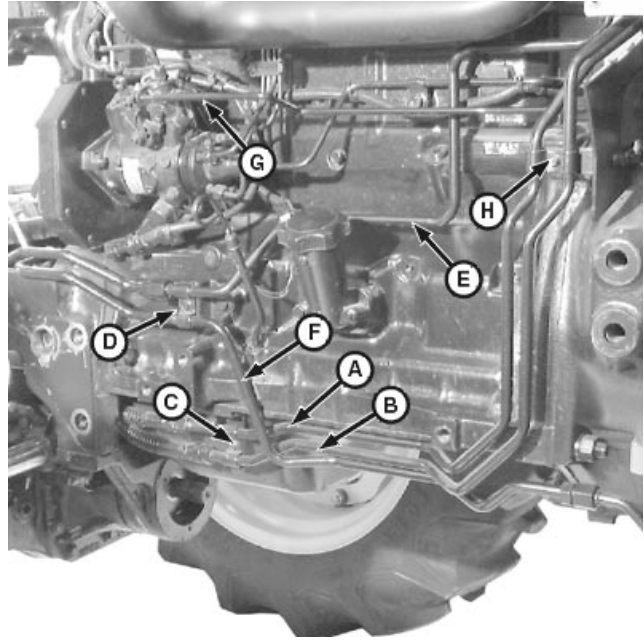

LV6646 -UN-17APR01

Continued on next page

OUC1089,00002FD -19-28FEB02-4/8