

JOHN DEERE
WORLDWIDE COMMERCIAL & CONSUMER
EQUIPMENT DIVISION

Compact Utility Tractors
4110 and 4115

TM1984 MAY 2002

TECHNICAL MANUAL



JOHN DEERE

North American Version
Litho in U.S.A.

INTRODUCTION

Manual Description

This technical manual is written for an experienced technician and contains sections that are specifically for this product. It is a part of a total product support program.

The manual is organized so that all the information on a particular system is kept together. The order of grouping is as follows:

- Table of Contents
- Specifications and Information
- Identification Numbers
- Tools and Materials
- Component Location
- Schematics and Harnesses
- Theory of Operation
- Operation and Diagnostics
- Diagnostics
- Tests and Adjustments
- Repair
- Other

NOTE: Depending on the particular section or system being covered, not all of the above groups may be used.

The bleed tabs for the pages of each section will align with the sections listed on this page. Page numbering is consecutive from the beginning of the Safety section through the last section.

We appreciate your input on this manual. If you find any errors or want to comment on the layout of the manual please contact us.

Safety

Specifications and Information

Engine (21 hp Diesel)

Engine (24 hp Diesel)

Electrical

Power Train (Gear)

Power Train (Hydro)

Hydraulics

Steering

Brakes

Miscellaneous

All information, illustrations and specifications in this manual are based on the latest information at the time of publication. The right is reserved to make changes at any time without notice.

COPYRIGHT© 2002
Deere & Co.
John Deere Worldwide Commercial and
Consumer Equipment Division
All rights reserved
Previous Editions
COPYRIGHT©

<https://www.ebooklibonline.com>

Hello dear friend!

Thank you very much for reading.

Enter the link into your browser.

The full manual is available for immediate download.

<https://www.ebooklibonline.com>

SAFETY

Recognize Safety Information



MIF

This is the safety-alert symbol. When you see this symbol on your machine or in this manual, be alert to the potential for personal injury.

Follow recommended precautions and safe servicing practices.

Understand Signal Words

A signal word - DANGER, WARNING, or CAUTION - is used with the safety-alert symbol. DANGER identifies the most serious hazards.

DANGER or WARNING safety signs are located near specific hazards. General precautions are listed on CAUTION safety signs. CAUTION also calls attention to safety messages in this manual.

Replace Safety Signs

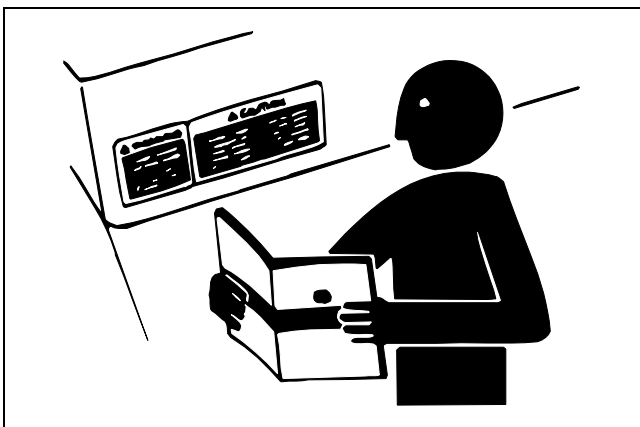

MIF

Replace missing or damaged safety signs. See the machine operator's manual for correct safety sign placement.

Handle Fluids Safely - Avoid Fires

Be Prepared For Emergencies

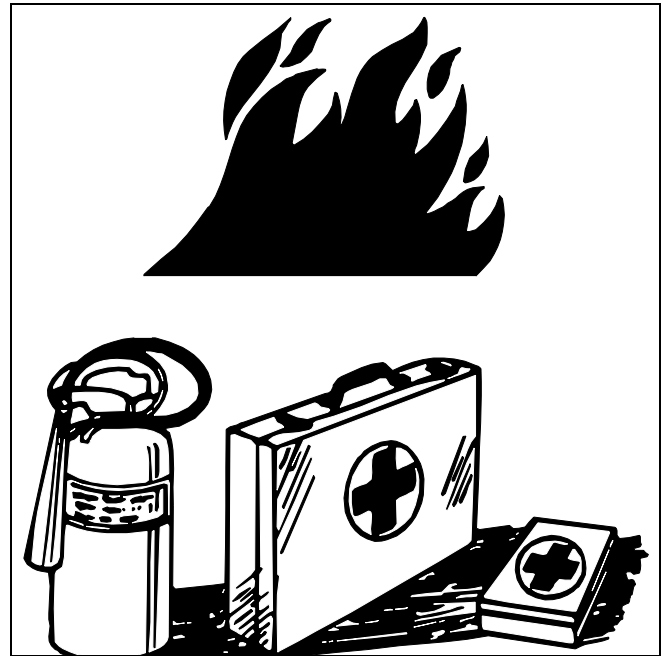

MIF

- When you work around fuel, do not smoke or work near heaters or other fire hazards.
- Store flammable fluids away from fire hazards. Do not incinerate or puncture pressurized containers.
- Make sure machine is clean of trash, grease, and debris.
- Do not store oily rags; they can ignite and burn spontaneously.
- Be prepared if a fire starts.
- Keep a first aid kit and fire extinguisher handy.
- Keep emergency numbers for doctors, ambulance service, hospital, and fire department near your telephone.

Use Care In Handling and Servicing Batteries

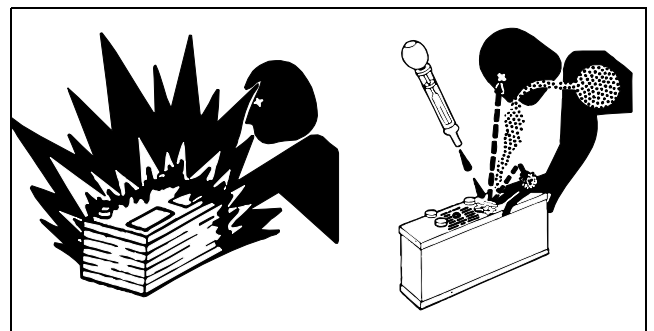

MIF

SAFETY

Prevent Battery Explosions

- Keep sparks, lighted matches, and open flame away from the top of battery. Battery gas can explode.
- Never check battery charge by placing a metal object across the posts. Use a volt-meter or hydrometer.
- Do not charge a frozen battery; it may explode. Warm battery to 16°C (60°F).

Prevent Acid Burns

- Sulfuric acid in battery electrolyte is poisonous. It is strong enough to burn skin, eat holes in clothing, and cause blindness if splashed into eyes.

Avoid acid burns by:

1. Filling batteries in a well-ventilated area.
2. Wearing eye protection and rubber gloves.
3. Avoiding breathing fumes when electrolyte is added.
4. Avoiding spilling or dripping electrolyte.
5. Use proper jump start procedure.

If you spill acid on yourself:

1. Flush your skin with water.
2. Apply baking soda or lime to help neutralize the acid.
3. Flush your eyes with water for 10 - 15 minutes.
4. Get medical attention immediately.

If acid is swallowed:

1. Drink large amounts of water or milk.
2. Then drink milk of magnesia, beaten eggs, or vegetable oil.
3. Get medical attention immediately.

Wear Protective Clothing

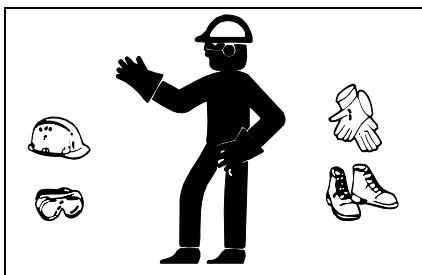

MIF

Wear close fitting clothing and safety equipment appropriate to the job.

Prolonged exposure to loud noise can cause impairment or loss of hearing. Wear a suitable hearing protective device

such as earmuffs or earplugs to protect against objectionable or uncomfortable loud noises.

Operating equipment safely requires the full attention of the operator. Do not wear radio or music headphones while operating machine.

Use Care Around High-pressure Fluid Lines

Avoid High-Pressure Fluids



MIF

Escaping fluid under pressure can penetrate the skin causing serious injury.

Avoid injury from escaping fluid under pressure by stopping the engine and relieving pressure in the system before disconnecting or connecting hydraulic or other lines. Tighten all connections before applying pressure.

Search for leaks with a piece of cardboard. Protect hands and body from high pressure fluids.

If an accident occurs, see a doctor immediately. Any fluid injected into the skin must be surgically removed within a few hours or gangrene may result. Doctors unfamiliar with this type of injury should reference a knowledgeable medical source. Such information is available from Deere & Company Medical Department in Moline, Illinois, U.S.A.

Avoid Heating Near Pressurized Fluid Lines



MIF

Flammable spray can be generated by heating near pressurized fluid lines, resulting in severe burns to yourself and bystanders. Do not heat by welding, soldering, or using a torch near pressurized fluid lines or other flammable materials. Pressurized lines can be accidentally cut when heat goes beyond the immediate flame area.

SAFETY

Service Machines Safely

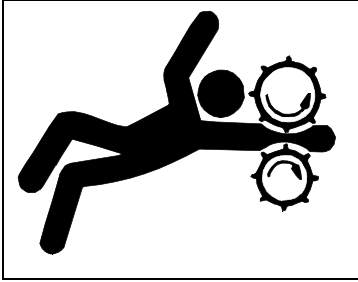

MIF

Tie long hair behind your head. Do not wear a necktie, scarf, loose clothing, or necklace when you work near machine tools or moving parts. If these items were to get caught, severe injury could result.

Remove rings and other jewelry to prevent electrical shorts and entanglement in moving parts.

Use Proper Tools

Use tools appropriate to the work. Makeshift tools and procedures can create safety hazards. Use power tools only to loosen threaded parts and fasteners. For loosening and tightening hardware, use the correct size tools. **DO NOT** use U.S. measurement tools on metric fasteners. Avoid bodily injury caused by slipping wrenches. Use only service parts meeting John Deere specifications.

Park Machine Safely

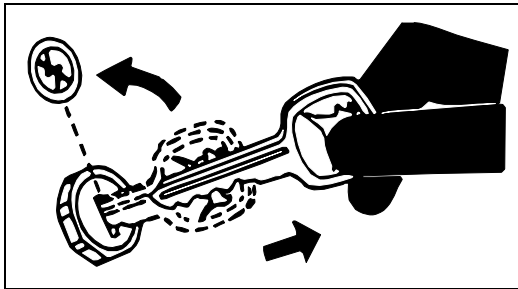

MIF

Before working on the machine:

1. Lower all equipment to the ground.
2. Stop the engine and remove the key.
3. Disconnect the battery ground strap.
4. Hang a "DO NOT OPERATE" tag in operator station.

Support Machine Properly and Use Proper Lifting Equipment

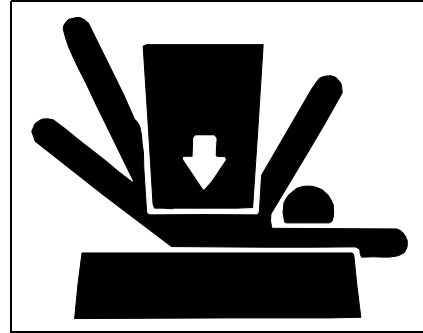

MIF

If you must work on a lifted machine or attachment, securely support the machine or attachment.

Do not support the machine on cinder blocks, hollow tiles, or props that may crumble under continuous load. Do not work under a machine that is supported solely by a jack. Follow recommended procedures in this manual.

Lifting heavy components incorrectly can cause severe injury or machine damage. Follow recommended procedure for removal and installation of components in the manual.

Work In Clean Area

Before starting a job:

1. Clean work area and machine.
2. Make sure you have all necessary tools to do your job.
3. Have the right parts on hand.
4. Read all instructions thoroughly; do not attempt shortcuts.

Using High Pressure Washers

Directing pressurized water at electronic/electrical components or connectors, bearings, hydraulic seals, fuel injection pumps or other sensitive parts and components may cause product malfunctions. Reduce pressure and spray at a 45 to 90 degree angle.

Illuminate Work Area Safely

Illuminate your work area adequately but safely. Use a portable safety light for working inside or under the machine. Make sure the bulb is enclosed by a wire cage. The hot filament of an accidentally broken bulb can ignite spilled fuel or oil.

SAFETY

Work In Ventilated Area

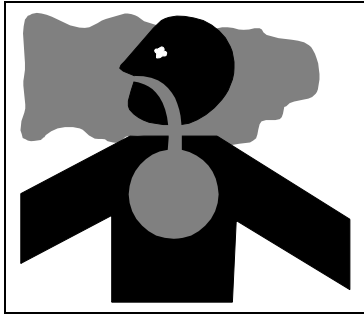

MIF

Engine exhaust fumes can cause sickness or death. If it is necessary to run an engine in an enclosed area, remove the exhaust fumes from the area with an exhaust pipe extension.

If you do not have an exhaust pipe extension, open the doors and get outside air into the area.

WARNING: California Proposition 65 Warning

Gasoline engine exhaust from this product contains chemicals known to the State of California to cause cancer, birth defects, or other reproductive harm.

Diesel engine exhaust and some of its constituents are known to the State of California to cause cancer, birth defects, and other reproductive harm.

Remove Paint Before Welding Or Heating

Avoid potentially toxic fumes and dust. Hazardous fumes can be generated when paint is heated by welding, soldering, or using a torch. Do all work outside or in a well ventilated area. Dispose of paint and solvent properly. Remove paint before welding or heating: If you sand or grind paint, avoid breathing the dust. Wear an approved respirator. If you use solvent or paint stripper, remove stripper with soap and water before welding. Remove solvent or paint stripper containers and other flammable material from area. Allow fumes to disperse at least 15 minutes before welding or heating.

Avoid Harmful Asbestos Dust

Avoid breathing dust that may be generated when handling components containing asbestos fibers. Inhaled asbestos fibers may cause lung cancer.

Components in products that may contain asbestos fibers are brake pads, brake band and lining assemblies, clutch plates, and some gaskets. The asbestos used in these components is usually found in a resin or sealed in some way. Normal handling is not hazardous as long as airborne dust containing asbestos is not generated.

Avoid creating dust. Never use compressed air for cleaning. Avoid brushing or grinding material containing asbestos. When servicing, wear an approved respirator. A special vacuum cleaner is recommended to clean asbestos. If not available, apply a mist of oil or water on the material containing asbestos. Keep bystanders away from the area.

Service Tires Safely

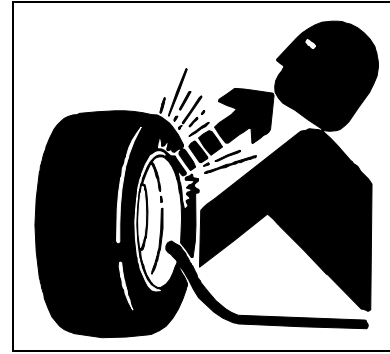

MIF

Explosive separation of a tire and rim parts can cause serious injury or death.

Do not attempt to mount a tire unless you have the proper equipment and experience to perform the job.

Always maintain the correct tire pressure. Do not inflate the tires above the recommended pressure. Never weld or heat a wheel and tire assembly. The heat can cause an increase in air pressure resulting in a tire explosion. Welding can structurally weaken or deform the wheel.

When inflating tires, use a clip-on chuck and extension hose long enough to allow you to stand to one side and NOT in front of or over the tire assembly. Use a safety cage if available.

Check wheels for low pressure, cuts, bubbles, damaged rims or missing lug bolts and nuts.

SAFETY

Avoid Injury From Rotating Blades, Augers and PTO Shafts

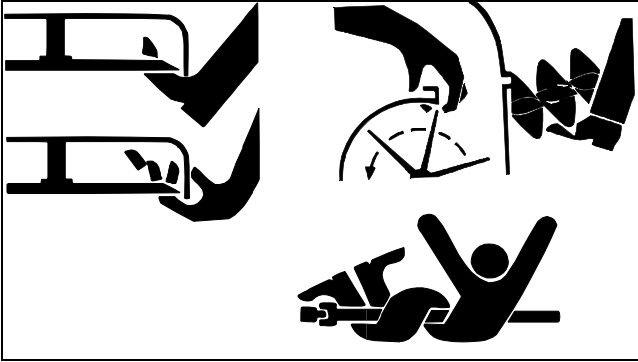

MIF

Keep hands and feet away while machine is running. Shut off power to service, lubricate or remove mower blades, augers or PTO shafts.

Service Cooling System Safely

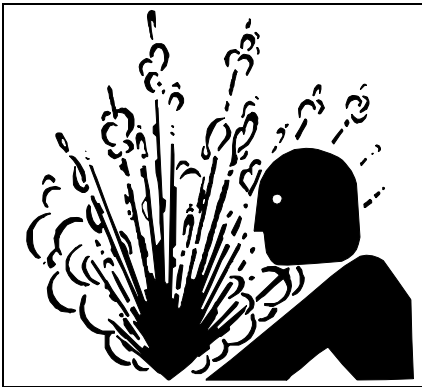

MIF

Explosive release of fluids from pressurized cooling system can cause serious burns.

Shut off machine. Only remove filler cap when cool enough to touch with bare hands. Slowly loosen cap to first stop to relieve pressure before removing completely.

Handle Chemical Products Safely

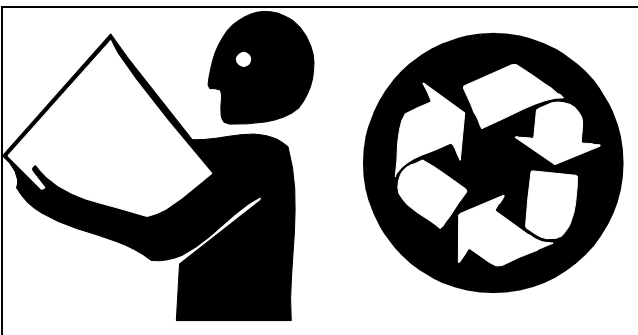

MIF

Direct exposure to hazardous chemicals can cause serious injury. Potentially hazardous chemicals used with John Deere equipment include such items as lubricants, coolants, paints, and adhesives.

A Material Safety Data Sheet (MSDS) provides specific details on chemical products: physical and health hazards, safety procedures, and emergency response techniques. Check the MSDS before you start any job using a hazardous chemical. That way you will know exactly what the risks are and how to do the job safely. Then follow procedures and recommended equipment.

Dispose Of Waste Properly

Improperly disposing of waste can threaten the environment and ecology. Potentially harmful waste used with John Deere equipment include such items as oil, fuel, coolant, brake fluid, filters, and batteries. Use leakproof containers when draining fluids. Do not use food or beverage containers that may mislead someone into drinking from them. Do not pour waste onto the ground, down a drain, or into any water source. Inquire on the proper way to recycle or dispose of waste from your local environmental or recycling center, or from your John Deere dealer.

Live With Safety



MIF

Before returning machine to customer, make sure machine is functioning properly, especially the safety systems. Install all guards and shields.

SAFETY



SPECIFICATIONS & INFORMATION TABLE OF CONTENTS

Table of Contents

Specifications	9
Engine	9
Electrical.....	10
Fuel System	10
Drive Train.....	10
PTO.....	10
3-Point Hitch.....	11
Clutch	11
Hydraulic System	11
Ground Speed (Forward)	11
Ground Speed (Reverse)	12
Capacities.....	12
Fastener Torques.....	14
Inch Fastener Torque Values	14
Metric Fastener Torque Values	15
O-Ring Seal Service Recommendations	16
Face Seal Fittings with Inch Stud Ends Torque.....	16
Face Seal Fittings with Metric Stud Ends Torque	17
O-Ring Face Seal Fittings	18
O-Ring Boss Fittings	18
General Information.....	19
Diesel Fuel Specifications	19
Diesel Fuel Lubricity	19
Diesel Fuel Storage.....	19
Engine Oil.....	19
Engine Break - in Oil	20
Alternative Lubricants.....	20
Synthetic Lubricants	21
Lubricant Storage	21
Mixing Of Lubricants.....	21
Chassis Grease	21
Transaxle Oil	22
Coolant Specifications	22
Engine Coolant.....	22
Engine Coolant Drain Interval	23
Serial Number Locations	23
Machine Product Identification Number	23
Engine Serial Number	23
Transaxle Serial Number.....	23

SPECIFICATIONS & INFORMATION TABLE OF CONTENTS



SPECIFICATIONS & INFORMATION SPECIFICATIONS

Specifications

Engine

4110 CST and 4110 HST

Make.....	John Deere/Yanmar
Model.....	3TNE74
Type.....	4-cycle Diesel
Bore.....	74 mm (2.91 in)
Stroke.....	78 mm (3.07 in)
Cylinders.....	3
Valves.....	Overhead
Displacement.....	1006 cm ³ (61.4 cu in.)
Gross Output Power (4110 CST).....	14.9 kW (20 hp)
Gross Output Power (4110 HST).....	15.7 kW (21 hp)
PTO Output.....	12.7 kW (17.0 hp)
Maximum Torque (4110 CST) (rpm).....	6.2 kg-m (45.3 lb-ft)(1600)
Maximum Torque (4110 HST) (rpm).....	6.4 kg-m (46.7 lb-ft)(1600)
Torque at Rated Speed.....	5.49 kg-m (39.7 lb-ft)
Engine Rated Speed.....	2650 rpm
Engine Slow Idle Speed.....	1000 rpm
Engine Fast Idle Speed.....	2850 ± 25 rpm
Lubrication.....	Full Pressure
Oil Filter.....	Spin On (Standard)
Cooling System.....	Liquid w/Pump and Radiator

4115 HST

Make.....	John Deere/Yanmar
Model.....	3TNE78A
Type.....	4-cycle Diesel
Bore.....	78 mm (3.07 in)
Stroke.....	84 mm (3.31 in)
Cylinders.....	3
Valves.....	Overhead
Displacement.....	1200 cm ³ (73.2 cu in.)
Gross Output Power.....	17.9 kW (24 hp)
Net Output Power.....	18.1 kW (24.3 hp)
PTO Output.....	14.9 kW (20.0 hp)
Maximum Torque (rpm).....	7.7 kg-m (55.8 lb-ft)(1600)
Torque at Rated Speed.....	6.57 kg-m (47.5 lb-ft)
Engine Rated Speed.....	2650 rpm
Engine Slow Idle speed.....	950 rpm
Engine Fast Idle Speed.....	2850 ± 25 rpm

SPECIFICATIONS & INFORMATION SPECIFICATIONS

Lubrication	Full Pressure
Oil Filter	Spin On (Standard)
Cooling System	Liquid w/Pump and Radiator

Electrical

All Models

Volts	12 VDC
Battery CCA @ -18°C (0°F)	435
Alternator (Standard)	20 amp
Alternator (Optional)	35 amps
Regulator Type	External, Current Limiting
Regulated Voltage @ 25°C (77°F)	14.2 - 14.8 VDC
Starting Motor	1.0 kW
Headlights	37.5 W Halogen Bulb
Tail Lights	5 W Bayonet Base
Hazard Lights	32 Cd/m ² , Single Element, Type 1156
Instrument Panel Lamps	1.7 W Bayonet Base

Fuel System

System Type (4110)	Indirect Fuel Injection
System Type (4115)	Direct Fuel Injection
Injection Pump	In-Line w/Electric Shutoff
Fuel Type	Diesel
Fuel Tank Capacity (4110)	22.0 L (5.81 gal)
Fuel Tank Capacity (4115)	27.0 L (7.13 gal)
Fuel Filter	Glass Bowl, Water Separator with Disposable Paper Element

Drive Train

Type (4110 CST)	Constant Mesh Gear Dual Range
Type	Hydrostatic Dual Range
Mechanical Front Wheel Drive (MFWD)	Sliding Gear Collar Shift
Differential Lock	Foot Operated
Number of Speeds (4110 CST)	8 Forward, 4 Reverse
Number of Speeds (4110 HST and 4115 HST)	Infinite, 2 Range
Final Drive	Spur Gear
Brakes	Wet Disk
Steering	Hydraulic Power Assist
Draw Bar Tongue Weight Capacity Rating	255 kg (562 lb)

SPECIFICATIONS & INFORMATION SPECIFICATIONS

PTO

Type (4110 CST)	Transmission Driven with Operator Released Clutch
Type (4110 HST and 4115 HST)	Independently Driven
Rotation Direction	Clockwise
Clutch (4110 CST)	None
Clutch (4110 HST and 4115 HST)	Wet Disk
Mid PTO Brake	Wet Disk
Rear Shaft Speed @2600 rpm (4110 CST)	546 rpm
Rear Shaft Speed @2600 rpm (4110 HST and 4115 HST)	541 rpm
Mid Shaft Speed @2650 rpm (4110 CST)	2100 rpm
Mid Shaft Speed @2650 rpm (4110 HST and 4115 HST)	2117 rpm
Shaft Diameter, Rear	34.82 mm (1.37 in.)
Shaft Diameter, Mid	25.4 mm (1.00 in.)
PTO Output Power (4110)	12.7 kW (17 hp)
PTO Output Power (4115)	14.9 kW (20 hp)

3-Point Hitch

All Models

Type	Category One
Lift Capacity at 610 mm (24 in.) Behind Link Arms	522 kg (1150 lb)
Total Lift Height	279 mm (10.98 in.)

Clutch

Type (4110 CST only)	Dry, Single Disc
Torque Capacity (4110 CST only)	147 Nm (108 lb-ft)

Hydraulic System

All Models

(Measurements Taken At Rated Engine rpm)

Type	Open Center / Dual Gear
Working Pressure	16685 kPa (2420 psi)
Steering Capacity	8.7 L/m (2.3 gpm)
Pump Capacity	19.3 L/m (5.1 gpm)
Total Pump Capacity	28.0 L/m (7.4 gpm)

SPECIFICATIONS & INFORMATION SPECIFICATIONS

Ground Speed (Forward)

4110 CST

(Measured At 2600 Engine rpm):

Rear Tires	8.0-16 R1 BS
1st (L1).....	1.19 km/h (0.74 mph)
2nd (L2).....	1.88 km/h (1.17 mph)
3rd (L3).....	2.38 km/h (1.48 mph)
4th (L4).....	3.76 km/h (2.34 mph)
5th (H1).....	5.00 km/h (3.11 mph)
6th (H2).....	7.92 km/h (4.92 mph)
7th (H3).....	11.38 km/h (7.07 mph)
8th (H4).....	18.02 km/h (11.20 mph)

4110 HST

(Measured At 2600 Engine rpm):

Rear Tires	9.5-16 R1 T1
Low Range	0-7.29 km/h (0-4.53 mph)
High Range	0-19.17 km/h (0-11.91 mph)

4115 HST

(Measured At 2650 Engine rpm):

Rear Tires	12.0-1.56 R1 T1
Low Range	0-7.40 km/h (0-4.60 mph)
High Range)	0-19.45 km/h (0-12.09 mph)

Ground Speed (Reverse)

4110 CST

(Measured At 2600 Engine rpm):

R1.....	0.98 km/h (0.61 mph)
R2.....	1.96 km/h (1.22 mph)
R3.....	4.12 km/h (2.56 mph)
R4.....	9.37 km/h (5.82 mph)

4110 HST

(Measured At 2600 Engine rpm):

Low Range	0-7.29 km/h (0-4.53 mph)
High Range	0-9.59 km/h (0-5.96 mph)

4115 HST

(Measured At 2650 Engine rpm):

Low Range	0-7.40 km/h (0-4.60 mph)
High Range	0-9.73 km/h (0-6.04 mph)

SPECIFICATIONS & INFORMATION SPECIFICATIONS

Capacities

4110 CST

Fuel Tank	22 L (5.81 gal)
Cooling System	2.4 L (0.63 gal)
Crankcase	2.2 L (0.58 gal)
Trans/Hyd System	13.5 L (3.57 gal)
MFWD Axle	3.4 L (0.9 gal)

4110 HST

Fuel Tank	22 L (5.81 gal)
Cooling System	2.4 L (0.63 gal)
Crankcase	2.2 L (0.58 gal)
Trans/Hyd System	13.3 L (3.51 gal)
MFWD Axle	3.4 L (0.9 gal)







4115 HST

Fuel Tank	27 L (7.13 gal)
Cooling System	2.4 L (0.63 gal)
Crankcase	2.0 L (0.53 gal)
Trans/Hyd System	14.6 L (3.86 gal)
MFWD Axle	3.4 L (0.9 gal)

SPECIFICATIONS & INFORMATION FASTENER TORQUES

Fastener Torques

Inch Fastener Torque Values

SAE Grade and Head Markings	1 or 2 ^b No Marks 	5 5.1 5.2 	8 8.2 
SAE Grade and Nut Markings	2 No Marks 	TS1162 	5 8 

SIZE	Grade 1		Grade 2b				Grade 5, 5.1 or 5.2				Grade 8 or 8.2					
	Lubricated a		Dry a		Lubricated a		Dry a		Lubricated a		Dry a		Lubricated a		Dry a	
	N•m	lb-ft	N•m	lb-ft	N•m	lb-ft	N•m	lb-ft	N•m	lb-ft	N•m	lb-ft	N•m	lb-ft	N•m	lb-ft
1/4	3.7	2.8	4.7	3.5	6	4.5	7.5	5.5	9.5	7	12	9	13.5	10	17	12.5
5/16	7.7	5.5	10	7	12	9	15	11	20	15	25	18	28	21	35	26
3/8	14	10	17	13	22	16	27	20	35	26	44	33	50	36	63	46
7/16	22	16	28	20	35	26	44	32	55	41	70	52	80	58	100	75
1/2	33	25	42	31	53	39	67	50	85	63	110	80	120	90	150	115
9/16	48	36	60	45	75	56	95	70	125	90	155	115	175	130	225	160
5/8	67	50	85	62	105	78	135	100	170	125	215	160	215	160	300	225
3/4	120	87	150	110	190	140	240	175	300	225	375	280	425	310	550	400
7/8	190	140	240	175	190	140	240	175	490	360	625	450	700	500	875	650
1	290	210	360	270	290	210	360	270	725	540	925	675	1050	750	1300	975
1-1/8	470	300	510	375	470	300	510	375	900	675	1150	850	1450	1075	1850	1350
1-1/4	570	425	725	530	570	425	725	530	1300	950	1650	1200	2050	1500	2600	1950
1-3/8	750	550	950	700	750	550	950	700	1700	1250	2150	1550	2700	2000	3400	2550
1-1/2	1000	725	1250	925	990	725	1250	930	2250	1650	2850	2100	3600	2650	4550	3350

DO NOT use these hand torque values if a different torque value or tightening procedure is given for a specific application. Torque values listed are for general use only and include a ±10% variance factor. Check tightness of fasteners periodically. DO NOT use air powered wrenches for assembly.

Shear bolts are designed to fail under predetermined loads. Always replace shear bolts with identical grade.

Fasteners should be replaced with the same grade. Make sure fastener threads are clean and that you properly start thread engagement. This will prevent them from failing when tightening.

When bolt and nut combination fasteners are used, torque values should be applied to the NUT instead of the bolt head. Tighten toothed or serrated-type lock nuts to the full torque value.

a "Lubricated" means coated with a lubricant such as engine oil, or fasteners with phosphate and oil coatings. "Dry" means plain or zinc plated (yellow dichromate - Specification JDS117) without any lubrication.

b "Grade 2" applies for hex cap screws (Not Hex Bolts) up to 152 mm (6 in.) long. "Grade 1" applies for hex cap screws over 152 mm (6 in.) long, and for all other types of bolts and screws of any length. Reference: JDS - G200

SPECIFICATIONS & INFORMATION FASTENER TORQUES

Metric Fastener Torque Values

Property Class and Head Markings				
Property Class and Nut Markings				

TS1163

SIZE	Class 4.8				Class 8.8 or 9.8				Class 10.9				Class 12.9			
	Lubricated a		Dry a		Lubricated a		Dry a		Lubricated a		Dry a		Lubricated a		Dry a	
	N•m	lb-ft	N•m	lb-ft	N•m	lb-ft	N•m	lb-ft	N•m	lb-ft	N•m	lb-ft	N•m	lb-ft	N•m	lb-ft
M6	4.8	3.5	6	4.5	9	6.5	11	8.5	13	9.5	17	12	15	11.5	19	14.5
M8	12	8.5	15	11	22	16	28	20	32	24	40	30	37	28	47	35
M10	23	17	29	21	43	32	55	40	63	47	80	60	75	55	95	70
M12	40	29	50	37	75	55	95	70	110	80	140	105	130	95	165	120
M14	63	47	80	60	120	88	150	110	175	130	225	165	205	150	260	109
M16	100	73	125	92	190	140	240	175	275	200	350	225	320	240	400	300
M18	135	100	175	125	260	195	330	250	375	275	475	350	440	325	560	410
M20	190	140	240	180	375	275	475	350	530	400	675	500	625	460	800	580
M22	260	190	330	250	510	375	650	475	725	540	925	675	850	625	1075	800
M24	330	250	425	310	650	475	825	600	925	675	1150	850	1075	800	1350	1000
M27	490	360	625	450	950	700	1200	875	1350	1000	1700	1250	1600	1150	2000	1500
M30	675	490	850	625	1300	950	1650	1200	1850	1350	2300	1700	2150	1600	2700	2000
M33	900	675	1150	850	1750	1300	2200	1650	2500	1850	3150	2350	2900	2150	3700	2750
M36	1150	850	1450	1075	2250	1650	2850	2100	3200	2350	4050	3000	3750	2750	4750	3500

DO NOT use these hand torque values if a different torque value or tightening procedure is given for a specific application. Torque values listed are for general use only and include a $\pm 10\%$ variance factor. Check tightness of fasteners periodically. DO NOT use air powered wrenches for assembly.

Shear bolts are designed to fail under predetermined loads. Always replace shear bolts with identical grade. Fasteners should be replaced with the same class. Make sure fastener threads are clean and that you properly start thread engagement. This will prevent them from failing

when tightening.

When bolt and nut combination fasteners are used, torque values should be applied to the NUT instead of the bolt head. Tighten toothed or serrated-type lock nuts to the full torque value.

a "Lubricated" means coated with a lubricant such as engine oil, or fasteners with phosphate and oil coatings. "Dry" means plain or zinc plated (Yellow Dichromate - Specification JDS117) without any lubrication. Reference: JDS - G200

SPECIFICATIONS & INFORMATION O-RING SEAL SERVICE

O-Ring Seal Service Recommendations

Face Seal Fittings with Inch Stud Ends Torque

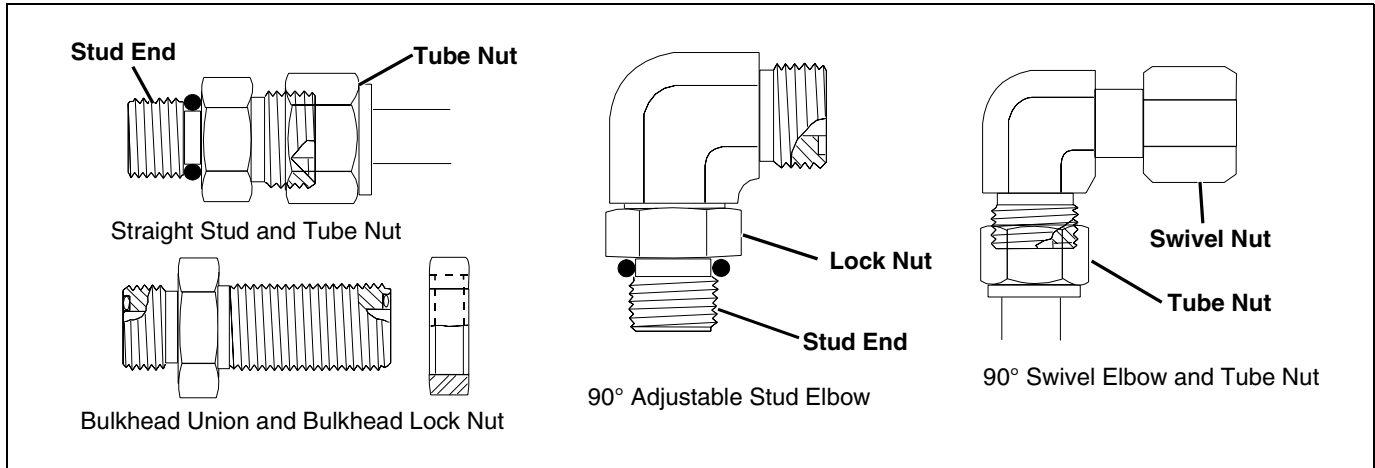

MIF

Nominal Tube OD/Hose ID				Face Seal Tube/Hose End					O-Ring Stud Ends		
Metric Tube OD	Inch Tube OD			Thread Size	Tube Nut/ Swivel Nut Torque		Bulkhead Lock Nut Torque		Thread Size	Straight Fitting or Lock Nut Torque	
	Dash Size	in.	mm		in.	N•m	lb-ft	N•m		lb-ft	in.
	-3	0.188	4.76						3/8-24	8	6
6	-4	0.250	6.35	9/16-18	16	12	12	9	7/16-20	12	9
8	-5	0.312	7.94						1/2-20	16	12
10	-6	0.375	9.52	11/16-16	24	18	24	18	9/16-18	24	18
12	-8	0.500	12.70	13/16-16	50	37	46	34	3/4-16	46	34
16	-10	0.625	15.88	1-14	69	51	62	46	7/8-14	62	46
	-12	0.750	19.05	1-3/16-12	102	75	102	75	1-1/16-12	102	75
22	-14	0.875	22.22	1-3/16-12	102	75	102	75	1-3/16-12	122	90
25	-16	1.000	25.40	1-7/16-12	142	105	142	105	1-5/16-12	142	105
32	-20	1.25	31.75	1-11/16-12	190	140	190	140	1-5/8-12	190	140
38	-24	1.50	38.10	2-12	217	160	217	160	1-7/8-12	217	160

NOTE: Torque tolerance is +15%, -20%

SPECIFICATIONS & INFORMATION O-RING SEAL SERVICE

Face Seal Fittings with Metric Stud Ends Torque

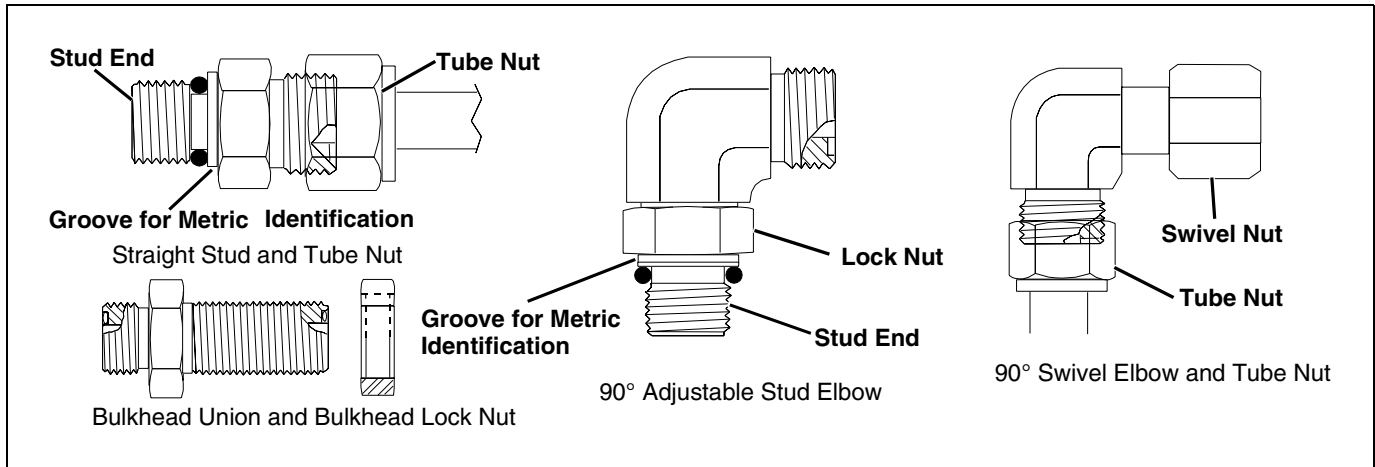

MIF

Nominal Tube OD/Hose ID				Face Seal Tube/Hose End						O-Ring Stud Ends, Straight Fitting or Lock Nut					
Metric Tube OD	Inch Tube OD			Thread Size	Hex Size	Tube Nut/ Swivel Nut Torque		Bulkhead Lock Nut Torque		Thread Size	Hex Size	Steel or Gray Iron Torque		Aluminum Torque	
	mm	Dash Size	in.			mm	in.	mm	N•m			lb-ft	N•m	lb-ft	mm
6	-4	0.250	6.35	9/16-18	17	16	12	12	9	M12X1.5	17	21	15.5	9	6.6
8	-5	0.312	7.94												
										M14X1.5	19	33	24	15	11
10	-6	0.375	9.52	11/16-16	22	24	18	24	18	M16X1.5	22	41	30	18	13
12	-8	0.500	12.70	13/16-16	24	50	37	46	34	M18X1.5	24	50	37	21	15
16	-10	0.625	15.88	1-14	30	69	51	62	46	M22X1.5	27	69	51	28	21
	-12	0.750	19.05	1-3/16-12	36	102	75	102	75	M27X2	32	102	75	46	34
22	-14	0.875	22.22	1-3/16-12	36	102	75	102	75	M30X2	36				
25	-16	1.000	25.40	1-7/16-12	41	142	105	142	105	M33X2	41	158	116	71	52
28										M38X2	46	176	130	79	58
32	-20	1.25	31.75	1-11/16-12	50	190	140	190	140	M42X2	50	190	140	85	63
38	-24	1.50	38.10	2-12	60	217	160	217	160	M48X2	55	217	160	98	72

NOTE: Torque tolerance is +15%, -20%

SPECIFICATIONS & INFORMATION O-RING SEAL SERVICE

O-Ring Face Seal Fittings

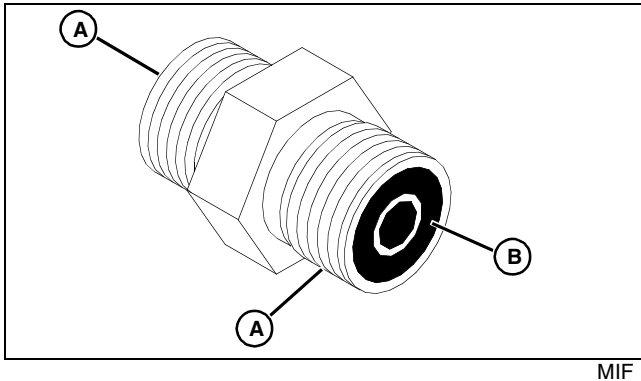

1. Inspect the fitting sealing surfaces (A). They must be free of dirt or defects.
2. Inspect the O-ring (B). It must be free of damage or defects.
3. Lubricate O-rings and install into groove using petroleum jelly to hold in place.
4. Push O-ring into the groove with plenty of petroleum jelly so O-ring is not displaced during assembly.
5. Index angle fittings and tighten by hand-pressing joint together to ensure O-ring remains in place.

IMPORTANT: Avoid damage! DO NOT allow hoses to twist when tightening fittings. Use two wrenches to tighten hose connections; one to hold the hose, and the other to tighten the swivel fitting.

6. Tighten fitting or nut to torque value shown on the chart per dash size stamped on the fitting.

O-Ring Boss Fittings

1. Inspect boss O-ring boss seat. It must be free of dirt and defects. If repeated leaks occur, inspect for defects with a magnifying glass. Some raised defects can be removed with a slip stone.

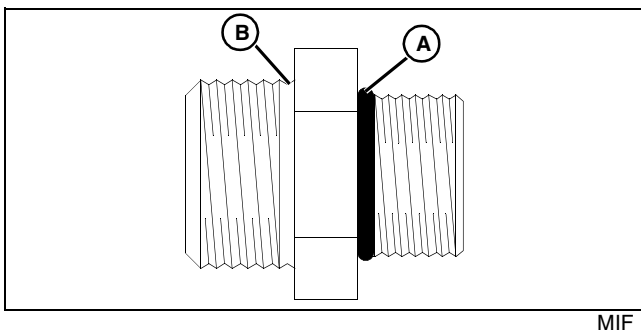

2. Put hydraulic oil or petroleum jelly on the O-ring (A). Place electrical tape over the threads to protect O-ring from nicks. Slide O-ring over the tape and into the groove (B) of fitting. Remove tape.

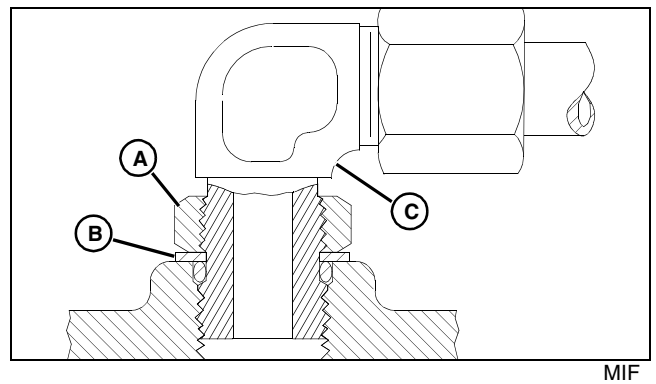

3. For angle fittings, loosen special nut (A) and push special washer (B) against threads so O-ring can be installed into the groove of fitting.
4. Turn fitting into the boss by hand until special washer or washer face (straight fitting) contacts boss face and O-ring is squeezed into its seat.
5. To position angle fittings (C), turn the fitting counter-clockwise a maximum of one turn.
6. Tighten straight fittings to torque value shown on chart. For angle fittings, tighten the special nut to value shown in the chart while holding body of fitting with a wrench.

Thread Size	Torque ^a		Number of Flats ^b
	N•m	lb-ft	
3/8-24 UNF	8	6	2
7/16-20 UNF	12	9	2
1/2-20 UNF	16	12	2
9/16-18 UNF	24	18	2
3/4-16 UNF	46	34	2
7/8-14 UNF	62	46	1-1/2
1-1/16-12 UN	102	75	1
1-3/16-12 UN	122	90	1
1-5/16-12 UN	142	105	3/4
1-5/8-12 UN	190	140	3/4
1-7/8-12 UN	217	160	1/2

^aTorque tolerance is ± 10 percent.

^bTo be used if a torque wrench cannot be used. After tightening fitting by hand, put a mark on nut or boss; then tighten special nut or straight fitting the number of flats shown.

SPECIFICATIONS & INFORMATION GENERAL INFORMATION

General Information

Diesel Fuel Specifications



CAUTION: Avoid injury! California Proposition 65 Warning: Diesel engine exhaust and some of its elements from this product are known to the State of California to cause cancer, birth defects, or other reproductive harm.

In general, diesel fuels are blended to satisfy the low air temperature requirements of the geographical area in which they are sold.

In North America, diesel fuel is usually specified to **ASTM D975** and sold as either **Grade 1** for cold air temperatures or **Grade 2** for warm air temperatures.

If diesel fuels being supplied in your area **DO NOT** meet any of the above specifications, use diesel fuels with the following equivalent properties:

- **Cetane Number 40 (minimum)**

A cetane number **greater than 50 is preferred**, especially for air temperatures below - 20°C (- 4°F) or elevations above 1500 m (5000 ft).

- **Cold Filter Plugging Point (CFPP)**

The air temperature at which diesel fuel **begins to cloud or jell** - at least 5°C (9°F) below the expected low air temperature range.

- **Sulfur Content of 0.05% (maximum)**

Diesel fuels for highway use in the United States now require sulfur content to be **less than 0.05%**.

If diesel fuel being used has a sulfur content **greater than 0.05%**, **reduce the service interval for engine oil and filter by 50%**.

Consult your local diesel fuel distributor for properties of the diesel fuel available in your area.

Diesel Fuel Lubricity

Diesel fuel must have adequate lubricity to ensure proper operation and durability of fuel injection system components. Fuel lubricity should pass a **minimum of 3300 gram load level** as measured by the **BOCLE** scuffing test.

Diesel Fuel Storage

IMPORTANT: Avoid damage! DO NOT USE GALVANIZED CONTAINERS - diesel fuel stored in galvanized containers reacts with zinc coating in the container to form zinc flakes. If fuel contains water, a zinc gel will also form. The gel and flakes will quickly plug fuel filters and damage fuel injectors and fuel pumps.

It is recommended that diesel fuel be stored **only** in a clean, approved **polyethylene plastic** container **without** any metal screen or filter. This will help prevent any accidental sparks from occurring. Store fuel in an area that is well ventilated to prevent possible igniting of fumes by an open flame or spark, this includes any appliance with a pilot light.

IMPORTANT: Avoid damage! Keep all dirt, scale, water or other foreign material out of fuel.

Keep fuel in a safe, protected area and in a clean, properly marked (“**DIESEL FUEL**”) container. **DO NOT** use de-icers to attempt to remove water from fuel. **DO NOT** depend on fuel filters to remove water from fuel. It is recommended that a water separator be installed in the storage tank outlet. **BE SURE** to properly discard unstable or contaminated diesel fuel and/or their containers when necessary.

Engine Oil

Use the appropriate oil viscosity based on the expected air temperature range during the period between recommended oil changes. Operating outside of these recommended oil air temperature ranges may cause premature engine failure.

The following John Deere oil is **PREFERRED**:

- TORQ - GARD SUPREME® - SAE 5W-30;
- PLUS - 50® - SAE 15W-40;

Other oils may be used if above John Deere oils are not available, provided they meet one of the following specifications:

- SAE 15W-40 - API Service Classification CH-4 or higher;
- SAE 10W-30 - API Service Classification CG-4 (4-cycle) or higher;

John Deere Dealers: You may want to cross-reference the following publications to recommend the proper oil for your customers:

- Module DX, ENOIL2 in JDS - G135;
- Section 530, Lubricants & Hydraulics, of the John Deere

SPECIFICATIONS & INFORMATION GENERAL INFORMATION

Merchandise Sales Guide;

- Lubrication Sales Manual PI7032.

Engine Break - in Oil

IMPORTANT: Avoid damage! ONLY use a quality break-in oil in rebuilt or remanufactured engines for the first 5 hours (maximum) of operation. DO NOT use oils with heavier viscosity weights than SAE 5W-30 or oils meeting specifications API SG or SH, these oils will not allow rebuilt or remanufactured engines to break-in properly.

The following John Deere oil is PREFERRED:

- **BREAK - IN ENGINE OIL.**

John Deere BREAK - IN ENGINE OIL is formulated with special additives for aluminum and cast iron type engines to allow the power cylinder components (pistons, rings, and liners as well) to “wear-in” while protecting other engine components, valve train and gears, from abnormal wear. Engine rebuild instructions should be followed closely to determine if special requirements are necessary.

John Deere BREAK - IN ENGINE OIL is also recommended for non-John Deere engines, both aluminum and cast iron types.

The following John Deere oil is **also recommended as a break-in engine oil:**

- TORQ - GARD SUPREME® - SAE 5W-30.

If the above recommended John Deere oils are not available, use a break-in engine oil meeting the following specification during the first 5 hours (maximum) of operation:

- SAE 5W-30 - API Service Classification SE or higher.

IMPORTANT: Avoid damage! After the break-in period, use the John Deere oil that is recommended for this engine.

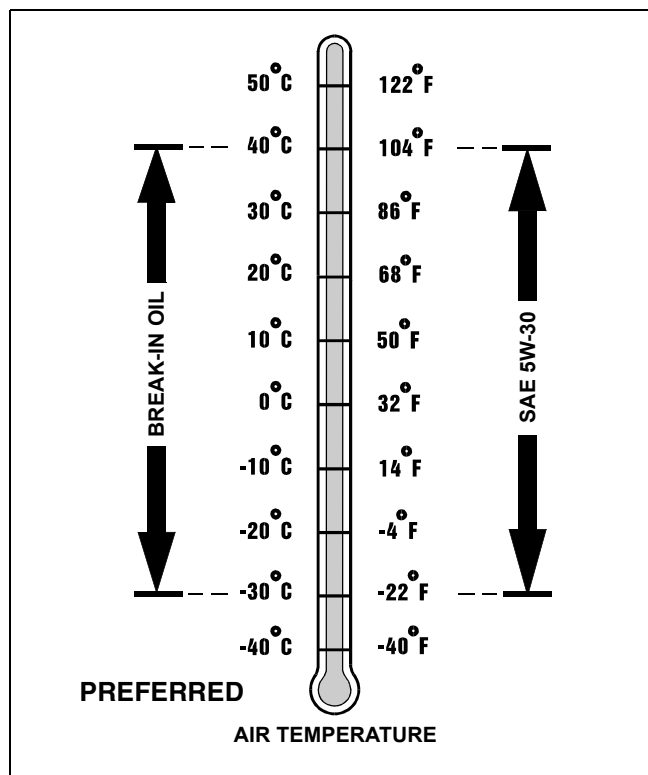

M58275

John Deere Dealers: You may want to cross-reference the following publications to recommend the proper oil for your customers:

- Module DX, ENOIL4 in JDS - G135;
- Section 530, Lubricants & Hydraulics, of the John Deere Merchandise Sales Guide;
- Lubrication Sales Manual PI7032.

Alternative Lubricants

Conditions in certain geographical areas outside the United States and Canada may require different lubricant recommendations than the ones printed in this technical manual or the operator's manual. Consult with your John Deere Dealer, or Sales Branch, to obtain the alternative lubricant recommendations.

IMPORTANT: Avoid damage! Use of alternative lubricants could cause reduced life of the component.

If alternative lubricants are to be used, it is recommended that the factory fill be thoroughly removed before switching to any alternative lubricant.

Synthetic Lubricants

Synthetic lubricants may be used in John Deere equipment if they meet the applicable performance requirements (industry classification and/or military specification) as shown in this manual.

The recommended air temperature limits and service or lubricant change intervals should be maintained as shown in the operator's manual.

Avoid mixing different brands, grades, or types of oil. Oil manufacturers blend additives in their oils to meet certain specifications and performance requirements. Mixing different oils can interfere with the proper functioning of these additives and degrade lubricant performance.

Lubricant Storage

All machines operate at top efficiency only when clean lubricants are used. Use clean storage containers to handle all lubricants. Store them in an area protected from dust, moisture, and other contamination. Store drums on their sides. Make sure all containers are properly marked as to their contents. Dispose of all old, used containers and their contents properly.

Mixing Of Lubricants

In general, avoid mixing different brands or types of lubricants. Manufacturers blend additives in their lubricants to meet certain specifications and performance requirements. Mixing different lubricants can interfere with the proper functioning of these additives and lubricant properties which will downgrade their intended specified performance.

Chassis Grease

Use the following grease based on the air temperature range. Operating outside of the recommended grease air temperature range may cause premature failures.

The following John Deere grease is **PREFERRED**:

- NON-CLAY HIGH-TEMPERATURE EP GREASE® - JDM J13E4, NLGI Grade 2.
- Multi-Purpose SD Polyurea Grease
- Multi-Purpose HD Lithium Complex Grease

Other greases may be used if above preferred John Deere grease is not available, provided they meet the following specification:

- John Deere Standard JDM J13E4, NLGI Grade 2.

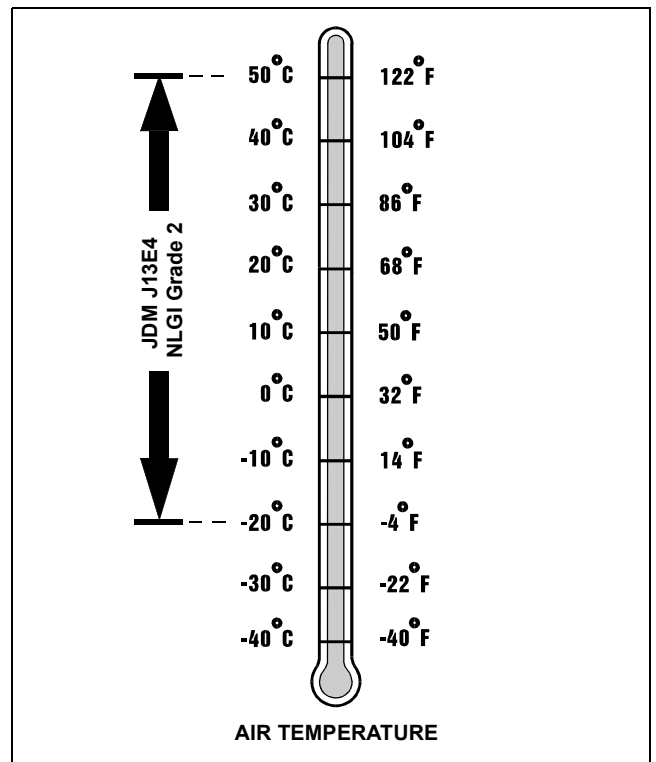

M58275

John Deere Dealers: You may want to cross-reference the following publications to recommend the proper grease for your customers:

- Module DX,GREA1 in JDS - G135;
- Section 530, Lubricants & Hydraulics, of the John Deere Merchandise Sales Guide;
- Lubrication Sales Manual P17032.

SPECIFICATIONS & INFORMATION COOLANT SPECIFICATIONS

Transaxle Oil

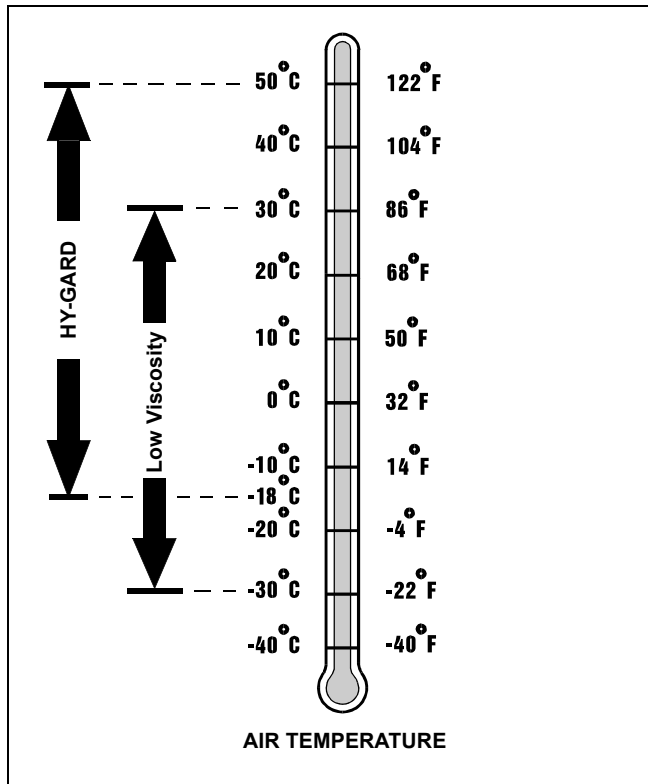

MIF

IMPORTANT: Avoid damage! Transaxle is filled with John Deere HY-Gard (J20C) transmission oil at the factory. DO NOT mix oils

Do not use type "F" automatic transmission fluid.

Use only Hy-Gard (J20C) or Low Viscosity Hy-Gard (J20D) transmission oil.

John Deere Hy-Gard transmission oil is specially formulated to provide maximum protection against mechanical wear, corrosion, and foaming.

The following John Deere oil is **PREFERRED**:

- **Hy-Gard J20C Oil**

The following oil is also recommended if above preferred oil is not available:

- **Low Viscosity Hy-Gard J20D Oil**

IMPORTANT: Avoid damage! If operating temperatures are below -18°C (0°F), you must use Low Viscosity HY-GARD® or transmission damage will occur.

Use the appropriate oil viscosity based on the air temperature ranges. Operating outside of these recommended oil air temperature ranges may cause premature gear case failure.

John Deere Dealers: You may want to cross-reference the following publications to recommend the proper oil for your customers:

- Module DX, ENOIL2 in JDS - G135;
- Section 530, Lubricants & Hydraulics, of the John Deere Merchandise Sales Guide;
- Lubrication Sales Manual PI7032.

Coolant Specifications

Engine Coolant

The engine cooling system, when filled with a proper dilution mixture of anti-freeze and deionized or distilled water, provides year-round protection against corrosion, cylinder or liner pitting, and winter freeze protection down to -37°C (-34°F).

The following John Deere coolant is **PREFERRED**:

- **PRE-DILUTED DIESEL ENGINE ANTI-FREEZE/SUMMER COOLANT™ (TY16036).**

This coolant satisfies specifications for "Automobile and Light Duty Engine Service" and is safe for use in John Deere Lawn and Grounds Care/Golf and Turf Division equipment, including aluminum block gasoline engines and cooling systems.

The above preferred pre-diluted anti-freeze provides:

- adequate heat transfer
- corrosion-resistant chemicals for the cooling system
- compatibility with cooling system hose and seal material
- protection during extreme cold and extreme hot weather operations
- chemically pure water for better service life
- compliance with ASTM D4656 (JDM H24C2) specifications

If above preferred pre-diluted coolant is not available, the following John Deere concentrate is **recommended**:

- **DIESEL ENGINE ANTI-FREEZE/SUMMER COOLANT CONCENTRATE™ (TY16034).**

If either of above recommended engine coolants are not available use any Automobile and Light Duty Engine Service **ethylene glycol base coolant**, meeting the following specification:

- ASTM D3306 (JDM H24C1).

Read container label completely before using and follow instructions as stated.

SPECIFICATIONS & INFORMATION SERIAL NUMBER LOCATIONS

IMPORTANT: Avoid damage! To prevent engine damage, DO NOT use pure anti-freeze or less than a 50% anti-freeze mixture in the cooling system. DO NOT mix or add any additives/conditioners to the cooling system in Lawn and Grounds Care/Golf and Turf Division equipment. Water used to dilute engine coolant concentrate must be of high quality - clean, clear, potable water (low in chloride and hardness - Table 1) is generally acceptable. DO NOT use salt water. Deionized or distilled water is ideal to use. Coolant that is not mixed to specified levels and water purity can cause excessive scale, sludge deposits, and increased corrosion potential.

Property	Requirements
Total Solids, Maximum	340 ppm (20 grns/gal)
Total Hardness, Maximum	170 ppm (10 grns/gal)
Chloride (as Cl), Maximum	40 ppm (2.5 grns/gal)
Sulfate (as SO ₄), Maximum	100 ppm (5.8 grns/gal)

Mix 50 percent anti-freeze concentrate with 50 percent distilled or deionized water. This mixture and the prediluted mixture (TY16036) will protect the cooling system down to -37°C (-34°F) and up to 108°C (226°F).

Certain geographical areas may require lower air temperature protection. See the label on your anti-freeze container or consult your John Deere dealer to obtain the latest information and recommendations.

Engine Coolant Drain Interval

When using **John Deere Pre-Diluted (TY16036)** Automobile and Light Duty Engine Service coolants, drain and flush the cooling system and refill with fresh coolant mixture every **36 months or 3,000 hours** of operation, whichever comes first.

When using **John Deere Concentrate (TY16034)** Automobile and Light Duty Engine Service coolants, drain and flush the cooling system and refill with fresh coolant mixture every **24 months or 2,000 hours** of operation, whichever comes first.

If above John Deere Automobile and Light Duty Engine Service coolants **are not** being used, drain, flush, and refill the cooling system according to instructions found on product container or in equipment operator's manual or technical manual.

Serial Number Locations

Machine Product Identification Number

When ordering parts or submitting a warranty claim, it is **IMPORTANT** that the machine product identification number (PIN) and component serial numbers are included. The location of the PIN and component serial numbers are shown.

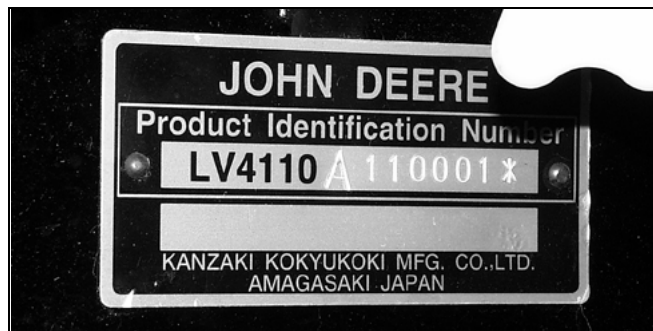

MX5200

Located on right-hand side of frame beneath the front of the engine.

Engine Serial Number

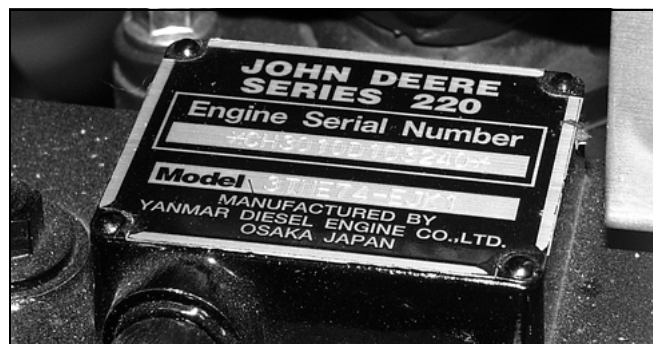

MX10704

Located on top of the engine rocker cover.

Transaxle Serial Number

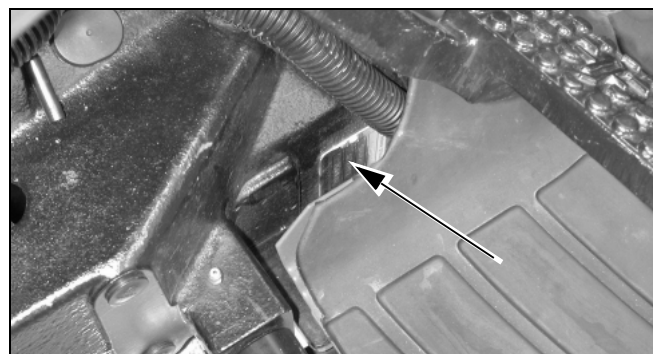

MX10703

Located on left-hand side of transmission housing.



ENGINE - 21 HP DIESEL TABLE OF CONTENTS

Table of Contents	Repair	61
	Muffler Removal and Installation	61
	Thermostat Removal and Installation	61
	Rocker Arm Cover Removal and Installation	62
	Rocker Arm and Push Rods	63
	Radiator Removal and Installation.....	65
	Cylinder Head Removal and Installation.....	66
	Intake Manifold Removal and Installation	67
	Exhaust Manifold Removal and Installation.	68
	Cylinder Head Recondition	68
	Engine Removal and Installation	72
	Front Sub-Frame Removal and Installation .	77
	Crankshaft Oil Seals	78
	Timing Gear Cover	79
	Camshaft End Play Check.....	81
	Timing Gear Backlash Check	81
	Idler Gear.....	82
	Camshaft Followers	83
	Camshaft	83
	Oil Pan and Strainer	87
	Connecting Rod Side Play Check.....	87
	Crankshaft End Play Check	87
	Connecting Rod Bearing Clearance Check.	88
	Crankshaft Main Bearing Clearance Check.	89
	Piston and Connecting Rod Repair	89
	Cylinder Bore	94
	Crankshaft and Main Bearings	96
	Flywheel Removal and Installation	98
	Engine Back Plate	99
	Clutch Removal and Installation	100
	Clutch Adjustment.....	102
	Timing Gear Housing.....	103
	Oil Pump	103
	Oil Pressure Regulating Valve.....	105
	Coolant Temperature Switch	105
	Thermostat.....	106
	Water Pump.....	106
	Fuel Transfer Pump.....	107
	Fuel Filter/Water Separator	107
	Fuel Injection Nozzle	108
	Fuel Injection Pump.....	110
	Fuel Shutoff Solenoid Removal and Installation	114
	Governor Assembly	115
Specifications		27
General.....		27
Repair Specifications.....		27
Tests and Adjustment Specifications		32
Operational Tests		32
Tightening Torques		33
Theory of Operation		34
Cooling System Theory of Operation		34
Lubrication System Theory of Operation.....		35
Fuel System Theory of Operation		36
Air System Theory of Operation		37
Component Location		38
Fuel System Component Location		38
Diagnostics		39
Engine Troubleshooting		39
Tests and Adjustments		49
Cylinder Compression Test		49
Throttle Adjustment		49
Slow Idle Adjustment.....		50
Valve Clearance Adjustment		50
Valve Lift Check		52
Fuel Injection System Tests		52
Fuel Injection Nozzle Test		53
Injection Pump Timing (EPA Engines)		54
Thermostat Test		55
Water Pump/alternator Drive Belt Adjustment		55
Radiator Bubble Test.....		56
Cooling System Pressure Test.....		56
Radiator Cap Pressure Test.....		57
Engine Oil Pressure Test		57
Fuel Transfer Pump Pressure Test		58
Fuel Transfer Pump Flow Test		58
Fuel System Air Bleeding		59
Air Restriction Indicator Test		60

ENGINE - 21 HP DIESEL TABLE OF CONTENTS



ENGINE - 21 HP DIESEL SPECIFICATIONS

Specifications

General

Make	Yanmar
Model 4110	3TNE74
Type	4-Cycle Diesel
Gross Power @2650 rpm	15.9 kW (21 HP)
Torque @2650 rpm	53.8 N•m (39.7 lb-ft)
Number of Cylinders	3
Bore	74 mm (2.91 in.)
Stroke	78 mm (3.07 in.)
Displacement	1.006 L (61.4 cu in.)
Firing Order	1 - 3 - 2
Direction of Rotation	Counterclockwise (viewed from flywheel)
Combustion System	Indirect Injection Type
Compression Ratio	23 to 1
Cooling	Liquid
Oil Capacity (w/filter)	Approximately 2.7 L (2.85 qt)
Governor	Centrifugal
Slow Idle (no-load)	1000 rpm
High Idle (no-load)	2850 rpm

Repair Specifications

Valve Train:

Rocker Arm Shaft OD	11.966 - 11.984 mm (0.471 - 0.472 in.)
Wear Limit	11.95 mm (0.470 in.)
Rocker Arm and Shaft Support Bushings ID	12.00 - 12.02 mm (0.472 - 0.473 in.)
Wear Limit	12.09 mm (0.476 in.)
Oil Clearance	0.016 - 0.054 mm (0.0006 - 0.0021 in.)
Wear Limit	0.14 mm (0.006 in.)
Push Rod Bend (maximum)	0.0 - 0.03 mm (0.0 - 0.001 in.)
Cylinder Head Distortion	0.000 - 0.05 mm (0.000 - 0.002 in.)
Wear Limit	0.15 mm (0.006 in.)

Valve Seat Width (Non-Removable):

Intake	1.44 mm (0.057 in.)
Wear Limit	1.98 mm (0.078 in.)
Exhaust	1.77 mm (0.070 in.)
Wear Limit	2.27 mm (0.089 in.)

Valve Seat Angles:

Exhaust Valve	45°
---------------	-----

ENGINE - 21 HP DIESEL SPECIFICATIONS

Intake Valve	30°
Lower Seat Surface	70°
Upper Seat Surface	15°
Intake Valve Head Margin	0.99 - 1.29 mm (0.004 - 0.005 in.)
Exhaust Valve Head Margin	0.95 - 1.25 mm (0.004 - 0.005 in.)
Wear Limit	0.50 mm (0.002 in.)

Valve Recession:

Intake	0.40 - 0.60 mm (0.016 - 0.024 in.)
Exhaust	0.75 - 0.95 mm (0.030 - 0.0374 in.)
Wear Limit (Intake and Exhaust)	1.0 mm (0.039 in.)

Valve Stem Diameter:

Intake	6.960 - 6.975 mm (0.274 - 0.274 in.)
Exhaust	6.945 - 6.960 mm (0.273 - 0.276 in.)
Wear Limit (Intake and Exhaust)	6.90 mm (0.272 in.)

Valve Guide:

ID	7.005 - 7.020 mm (0.275 - 0.276 in.)
Wear Limit	7.08 mm (0.279 in.)
Installed Height	9 mm (0.354 in.)

Valve Stem-To-Guide Oil Clearance:

Intake	0.030 - 0.060 mm (0.001 - 0.002 in.)
Exhaust	0.045 - 0.075 mm (0.002 - 0.003 in.)
Wear Limit	0.18 mm (0.007 in.)

Valve Springs:

Free Length	37.4 mm (1.472 in.)
Maximum Inclination	1.0 mm (0.032 in.)
Tension Measured With Spring Compressed 1.0 mm (0.039)	2.37 - 1.87 kg (5.22 - 4.12 lb)

Connecting Rod:

Large End Bearing ID	43.000 - 43.016 mm (1.693 - 1.694 in.)
Large End Bearing Thickness	1.487 - 1.500 mm (0.058 - 0.059 in.)
0.25 mm (0.010 in.) Oversize Bearing Thickness	1.625 mm (0.064 in.)
Large End Bearing Oil Clearance	0.033 - 0.059 mm (0.001 - 0.002 in.)
Large End Bearing Wear Limit	0.15 mm (0.006 in.)
Connecting Rod Side Play	0.20 - 0.40 mm (0.008 - 0.016 in.)
Twist and Parallelism	0.00 - 0.03 mm per 100 mm (0.00 - 0.001 in. per 6 in.)
Wear Limit	0.08 mm per 100 mm (0.005 in. per 6 in.)

(For Connecting Rod Small End Specifications, See "Piston Pin" Below)

Top Piston Ring Specifications:

Ring Groove Width	1.550 - 1.570 mm (0.061 - 0.062 in.)
Ring Width	1.470 - 1.490 mm (0.058 - 0.059 in.)
Minimum Side Clearance	0.060 - 0.100 mm (0.002 - 0.004 in.)

ENGINE - 21 HP DIESEL SPECIFICATIONS

Ring End Gap	0.200 - 0.400 mm (0.008 - 0.016 in.)
2nd Piston Ring Specifications:	
Piston Groove Width	1.520 - 1.535 mm (0.059 - 0.060 in.)
Ring Width	1.410 - 1.430 mm (0.055 - 0.056 in.)
Minimum Side Clearance	0.090 - 0.125 mm (0.004 - 0.005 in.)
Ring End Gap	0.200 - 0.400 mm (0.008 - 0.015 in.)
Oil Control Ring Specifications:	
Piston Groove Width	3.010 - 3.025 mm (0.118 - 0.119 in.)
Ring Width	2.970 - 2.990 mm (0.117 - 0.118 in.)
Minimum Side Clearance	0.020 - 0.055 mm (0.0008 - 0.002 in.)
Ring End Gap	0.150 - 0.350 mm (0.006 - 0.014 in.)
Ring End Gap Wear Limit (All Rings)	1.5 mm (0.059 in.)
Piston Pin Specifications:	
Piston Pin OD	20.99 - 21.00 mm (0.826 - 0.827 in.)
Wear Limit	20.90 mm (0.823 in.)
Connecting Rod Bushing ID	21.025 - 21.038 mm (0.828 - 0.828 in.)
Wear Limit	21.10 mm (0.831 in.)
Piston Pin-To-Rod Bushing:	
Oil Clearance	0.025 - 0.047 mm (0.001 - 0.002 in.)
Wear Limit	0.2 mm (0.008 in.)
Piston Pin Bore (In Piston) ID	21.000 - 21.008 mm (0.827 - 0.827 in.)
Wear Limit	21.02 mm (0.828 in.)
Piston Pin-To-Piston Oil Clearance	0.000 - 0.017 mm (0 - 0.0007 in.)
Wear Limit	0.12 mm (0.005 in.)
Piston (Measured 24 mm (0.945 in.) up from bottom of piston skirt, perpendicular to piston pin.):	
Standard Piston OD	73.955 - 73.980 mm (2.912 - 2.913 in.)
Wear Limit	73.90 mm (2.909 in.)
Oversize Piston - 0.25 mm (0.010 in.) OD	74.205 - 74.230 mm (2.921 - 2.922 in.)
Wear Limit	74.15 mm (2.919 in.)
Cylinder Bore:	
Standard ID	74.00 - 74.03 mm (2.913 - 2.915 in.)
Wear Limit	74.20 mm (2.921 in.)
Oversize Bore - 0.25 mm (0.010 in.) ID	74.25 - 74.28 mm (2.923 - 2.924 in.)
Clearance (Piston-To-Cylinder)	0.030 - 0.060 mm (0.001 - 0.002 in.)
Cylinder Roundness	0.00 - 0.01 mm (0 - 0.0004 in.)
Cylinder Roundness Wear Limit	0.03 mm (0.001 in.)
Cylinder Taper	0.00 - 0.01 mm (0 - 0.0004 in.)
Cylinder Taper Wear Limit	0.03 mm (0.001 in.)

ENGINE - 21 HP DIESEL SPECIFICATIONS

Deglazing	30 - 40° crosshatch pattern
Reboring	30 - 40° crosshatch pattern
Crankshaft:	
Connecting Rod Crankpin Journal:	
OD	39.97 - 39.98 mm (1.573 - 1.574 in.)
Wear Limit	39.91 mm (1.571 in.)
Connecting Rod Bearing:	
Inside Diameter	43.000 - 43.016 mm (1.693 - 1.694 in.)
Thickness	1.487 - 1.500 mm (0.058 - 0.059 in.)
0.25 mm (0.010 in.) Oversize Bearing Thickness	1.625 mm (0.064 in.)
Oil Clearance	0.033 - 0.059 mm (0.001 - 0.002 in.)
Wear Limit	0.15 mm (0.006 in.)
Main Bearing Journal:	
Outside Diameter	43.970 - 43.980 mm (1.728 - 1.732 in.)
Wear Limit	43.90 mm (1.728 in.)
Main Bearing:	
Insert Thickness	1.987 - 2.000 mm (0.078 - 0.079 in.)
0.25 mm (0.010 in.) Under Size Bearing Thickness	2.125 mm (0.084 in.)
Oil Clearance	0.033 - 0.059 mm (0.001 - 0.002 in.)
Wear Limit	0.15 mm (0.006 in.)
Thrust Bearing Insert Thickness	1.93 - 1.98 mm (0.076 - 0.078 in.)
0.25 mm (0.010 in.) Oversize Thrust Bearing Thickness	2.125 mm (0.084 in.)
Crankshaft Maximum Bend	0.02 mm (0.0008 in.)
Crankshaft End Play	0.090 - 0.271 mm (0.004 - 0.011 in.)
Camshaft:	
Camshaft End Play	0.05 - 0.25 mm (0.002 - 0.010 in.)
Maximum Camshaft Bend	0 - 0.02 mm (0 - 0.0008 in.)
Camshaft Wear Limit	0.05 mm (0.002 in.)
Front Journal:	
OD (Camshaft Gear Side)	35.940 - 35.960 mm (1.572 - 1.573 in.)
Wear Limit	39.85 mm (1.569 in.)
Oil Clearance	0.040 - 0.085 mm (0.002 - 0.003)
Intermediate Journals:	
OD	39.910 - 39.935 mm (1.571 - 1.572 in.)
Wear Limit	39.85 mm (1.569 in.)
Oil Clearance	0.065 - 0.115 mm (0.002 - 0.005 in.)
Rear Journal:	
OD (Flywheel Side)	39.940 - 39.960 mm (1.572 - 1.573 in.)

ENGINE - 21 HP DIESEL SPECIFICATIONS

Wear Limit	39.85 mm (1.569 in.)
Oil Clearance	0.040 - 0.125 mm (0.002 - 0.005 in.)
Bushing:	
ID	40.075 - 40.140 mm (1.578 - 1.580 in.)
Wear Limit	40.18 mm (1.582 in.)
Clearance	0.040 - 0.125 mm (0.002 - 0.005 in.)
Cam Lobes:	
Lobe Height (Intake and Exhaust Lobes)	33.950 - 34.050 mm (1.33 - 1.34 in.)
Wear Limit	33.75 mm (1.329 in.)
Tappets:	
OD	20.927 - 20.960 mm (0.824 - 0.825 in.)
Wear Limit	20.90 mm (0.823 in.)
Cylinder Block Guide Hole ID	21.000 - 21.021mm (0.827 - 0.828 in.)
Wear Limit	21.05 mm (0.829 in.)
Oil Clearance	0.040 - 0.094 mm (0.002 - 0.004 in.)
Wear Limit	0.15 mm (0.006 in.)
Timing Gear Backlash:	
All Except Crankshaft Gear-to-Oil Pump Gear	0.04 - 0.12 mm (0.0016 - 0.0047 in.)
Crankshaft Gear-to-Oil Pump Gear	0.11 - 0.19 mm (0.004 - 0.008 in.)
Idler Gear:	
Shaft Outside Diameter	19.959 - 19.980 mm (0.786 - 0.787 in.)
Shaft Wear Limit	19.93 mm (0.785 in.)
Bushing Inside Diameter	20.000 - 20.021 mm (0.787 - 0.788 in.)
Oil Clearance	0.020 - 0.062 mm (0.0008 - 0.002 in.)
Oil Clearance Wear Limit	0.15 mm (0.006 in.)
Flywheel:	
Maximum Distortion	0.02 mm (0.0008 in.)
Oil Pump:	
Rotor Shaft OD-to-Back Plate ID Clearance	0.013 - 0.043 mm (0.0005 - 0.002 in.)
Wear Limit	0.20 mm (0.008 in.)
Outer Rotor-to-Pump Body Clearance	0.10 - 0.16 mm (0.004 - 0.006 in.)
Wear Limit	0.25 mm (0.010 in.)
Inner Rotor-to-Outer Rotor Clearance Wear Limit	0.15 mm (0.006 in.)
Inner and Outer Rotor-to-Back Plate Side Clearance	0.03 - 0.09 mm (0.001 - 0.004 in.)
Inner and Outer Rotor-to-Back Plate Side Clearance Wear Limit	0.13 mm (0.005 in.)
Oil Pressure Regulating Valve:	
Spring Compressed Length	14.70 mm (0.580 in.) @12 N (2.7 lb)
Spring Free Length	21.90 - 24.50 mm (0.860 - 0.960 in.)

ENGINE - 21 HP DIESEL SPECIFICATIONS

Fuel Injection Pump:

Fuel Pump Pressure 29 kPa (4.3 psi)

Fuel Pump Flow Volume 118 cm³/min (4 ounces/min)

Fuel Injection Pump Camshaft:

Bearing Retaining Screw Torque 20 N•m (180 lb-in.)

Minimum Lobe Height 30.90 mm (1.217 in.)

Fuel Control and Governor Linkage:

Governor Shaft OD (Minimum) 7.90 mm (0.311 in.)

Sleeve ID (Maximum) 8.25 mm (0.325 in.)

Injection Pump Camshaft OD (Minimum) 7.90 mm (0.311 in.)

Fuel Injection Nozzles:

Separator Plate Nozzle Contact Surface Maximum Wear 0.10 mm (0.0039 in.)

Cooling System:

Coolant Temperature Switch Continuity (Closing) Temperature 107 - 113 °C (225 - 235 °F)

Radiator Bubble Test (Maximum Air Pressure Into Cylinder) 2448 kPa (355 psi)

Tests and Adjustment Specifications

Valve Clearance 0.15 - 0.25 mm (0.006 - 0.010 in.)

Connecting Rod Side Play 0.2 - 0.4 mm (0.008 - 0.016 in.)

Connecting Rod Bearing Clearance 0.03 - 0.06 mm (0.001 - 0.002 in.)

Crankshaft End Play 0.09 - 0.27 mm (0.004 - 0.011 in.)

Crankshaft Main Bearing Clearance 0.04 - 0.09 mm (0.002 - 0.004 in.)

Camshaft End Play 0.05 - 0.25 mm (0.002 - 0.010 in.)

Fuel Injection Nozzle:

Opening Pressure 19600 + 1000/ - 0 kPa (2844 + 145/ - 0 psi)

Leakage at 11032 kPa (1600 psi) None for a minimum of 10 seconds

Chatter and Spray Pattern at 19600 ± 1000 kPa (2843 ± 145 psi):

Slow Hand Lever Movement Chatter Sound

Slow Hand Lever Movement Fine Stream

Fast Hand Lever Movement Fine Atomized Spray; 150° Spray Pattern

Alternator Drive Belt Deflection @ 98 N (22 lb) Applied Force 10 - 15 mm (0.4 - 0.6 in.)

Operational Tests

Cylinder Compression Pressure @250 RPM Cranking Speed 3432 kPa (498 psi)

(Minimum) 2746 kPa (398 psi)

Difference Between Cylinders 245 kPa (36psi)

Radiator Cap Opening Pressure 0.9 ± 0.15 kg/cm², 88.3 ± 14.7 kPa, (12.8 ± 2.2 psi)

Cooling System Pressure Test 0.9 ± 0.15 kg/cm², 88.3 ± 14.7 kPa, (12.8 ± 2.2 psi)

Thermostat Opening Temperature 69.5 - 72.5 °C (157 - 163 °F)

Thermostat Minimum Lift Height above 85 °C (185 °F) 8 mm (0.315 in.)

ENGINE - 21 HP DIESEL SPECIFICATIONS

Oil Pressure:

Rated Speed	290 ± 50 kPa (42 ± 7 psi)
Slow Idle (Minimum).....	60 kPa (9 psi)
Oil Relief Valve Opening Pressure	294 - 392 kPa (43 - 57 psi)
Oil Pressure Switch Opening Pressure	3 - 4 kPa (6 - 9 psi)

Tightening Torques

Cylinder Head Bolts (Lubricating Oil Applied)	59 - 64 N•m (44 - 47 lb-ft)
Connecting Rod Bolts (Lubricating Oil Applied).....	23 - 28 N•m (17 - 20 lb-ft)
Flywheel Mounting Bolts (Lubricating Oil Applied)	78 - 88 N•m (58 - 65 lb-ft)
Main Bearing Bolts (Lubricating Oil Applied)	58 - 61 N•m (43 - 45 lb-ft)
Crankshaft Pulley Cap Screw (Lubricating Oil Applied).....	83 - 93 N•m (61 - 69 lb-ft)
Fuel Injector Nozzle Nut.....	36 - 39 N•m (27 - 29 lb-ft)
Glow Plugs	15 - 20 N•m (11 - 15 lb-ft)
Governor Weight Support Nut.....	69 - 74 N•m (51 - 55 lb-ft)
Fuel Injector Line Nuts.....	36 - 39 N•m (27 - 29 lb-ft)
Rocker Arm Cover Special Nut	18 N•m (159 lb-in.)
Shaft Nut	27 N•m (20 lb-ft)
Mounting Cap Screw	25 N•m (18 lb-ft)
Fan Mounting Cap Screw.....	11 N•m (97 lb-in.)
Timing Cover Mounting Cap Screw	9 N•m (78 lb-in.)
Injector Pump-to-Timing Cover Cap Screw	20 N•m (15 lb-ft)
Exhaust Manifold Mounting Cap Screw and Nut.....	25 N•m (221 lb-in.)
Intake Manifold Mounting Cap Screw.....	11 N•m (97 lb-in.)
Rear Crankcase Oil Seal Case-to-Block Cap Screw	11 N•m (97 lb-in.)
Oil Pan-to-Seal Case Cap Screw	9 N•m (78 lb-in.)
Fuel Injection Nozzle Fitting Torque.....	40 N•m (30 lb-ft)
Fuel Injection Nozzle Torque	50 N•m (37 lb-ft)
Oil Pump Housing-to-Valve Body Retaining Nut.....	30 N•m (22 lb-ft)
Flywheel Mounting Cap Screw	79 - 88 N•m (58 - 65 lb-ft)
Engine Back Plate Mounting Cap Screw	91 N•m (67 lb-ft)
Oil Pan-to-Block	11 N•m (97 lb-in.)
Oil Pan-to-Seal Case	9 N•m (80 lb-in.)
Oil Pan-to-Timing Gear Housing.....	9 N•m (80 lb-in.)
Oil Strainer-to-Block.....	11 N•m (97 lb-in.)

Other Material

Part No.	Part Name	Part Use
TY15130 LOCTITE® No. 395	John Deere Form-In-Place Gasket	Seals crankcase extension housing, rear oil seal case and flywheel housing to engine block. Seals oil pan to timing gear housing and engine block.

LOCTITE® is a registered trademark of the Loctite Corp

ENGINE - 21 HP DIESEL THEORY OF OPERATION

Theory of Operation

Cooling System Theory of Operation

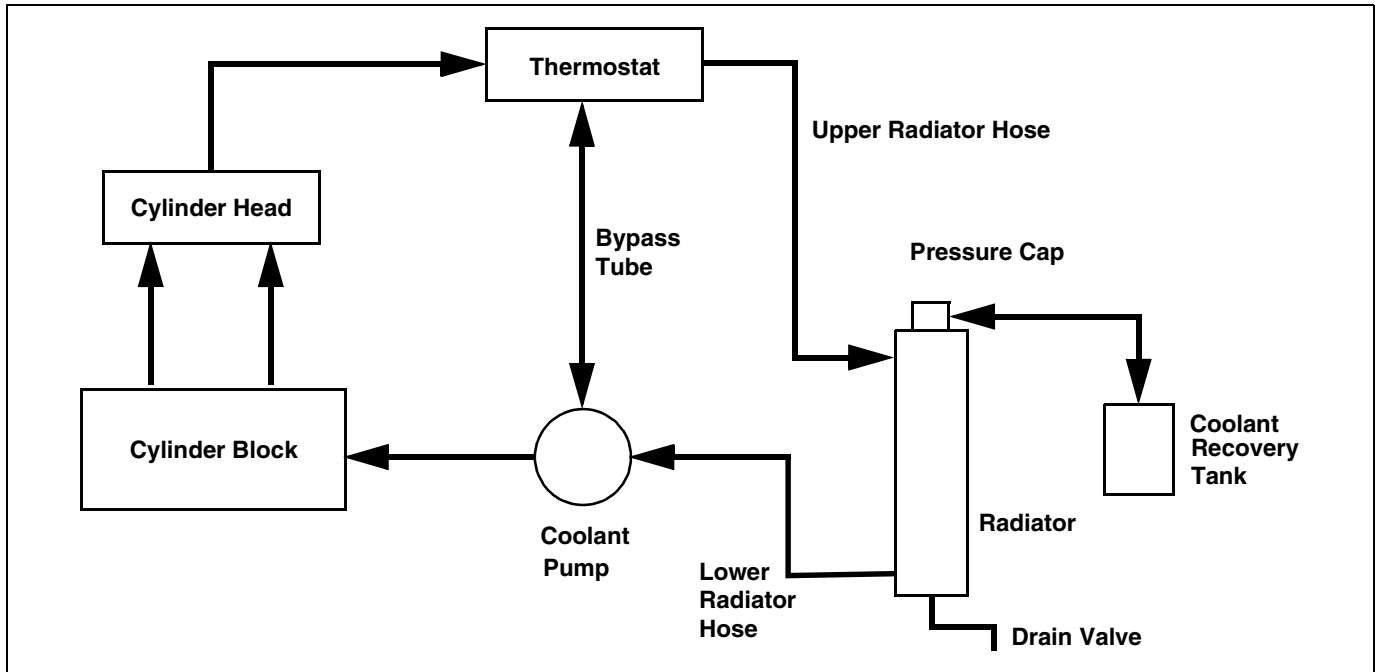

MIF

Function:

The cooling system allows the engine to rise to full operating temperature when engine is started cold, but keeps the engine from overheating once engine reaches operating temperature. The thermostat opens when operating temperature has been reached, circulating coolant from the hot engine to the radiator to prevent engine overheating. The cooling system is pressurized, which raises the boiling point of the coolant, and allows more heat to be carried away from the engine.

Theory of Operation:

The cooling system includes the following components: radiator, radiator cap, upper and lower radiator hoses, coolant pump, fan, thermostat, coolant recovery tank, drain hoses and drain valve.

When the engine is started cold, the thermostat is closed. The impeller type coolant pump pulls coolant from the cylinder head and through the bypass tube inside the water pump housing. The water pump then pushes the coolant into the cylinder block water jacket. The coolant absorbs heat from the cylinder walls, and is then pushed up into the cylinder head, and sucked back into the water pump. This provides a fast warm-up period, as engine heat is retained and evenly distributed throughout the engine.

As the engine has reached operating temperature, **69.5 - 72.5°C (157 - 163°F)**, the thermostat opens, and the hot coolant from the cylinder head passes through the thermostat and into the top tank of the radiator. As coolant

flows down through the tubes of the radiator core, heat is transferred from the coolant to the air stream being drawn through the core by the engine fan. When the coolant reaches the bottom radiator tank, it is sucked through the lower radiator hose and into the water pump, and pushed back into the cylinder block.

When coolant system pressure exceeds **88.3 ± 14.7 kPa (12.8 ± 2.2 psi)**, the spring in the radiator cap pushes open to allow coolant to discharge into the coolant recovery tank. As the engine cools after shutdown, a vacuum is produced in the cooling system, and coolant is drawn back out of the coolant recovery tank through a small valve in the bottom of the radiator cap.

Air is pulled by the engine fan through a removable debris guard on the front of the radiator, through the radiator and fan, and back over engine block. The engine fan belt drives both the water pump and the cooling fan.

An electrical coolant temperature switch is located in the thermostat housing. When the coolant temperature reaches **107 - 113°C (225 - 235°F)**, the coolant temperature switch closes, lighting the coolant warning lamp on the instrument panel. This informs the operator of the high temperature condition.

The radiator can be drained with a drain valve on the bottom right side of the engine. The coolant recovery tank can be drained from a removable rubber plug on the bottom of the recovery tank.

ENGINE - 21 HP DIESEL THEORY OF OPERATION

Lubrication System Theory of Operation

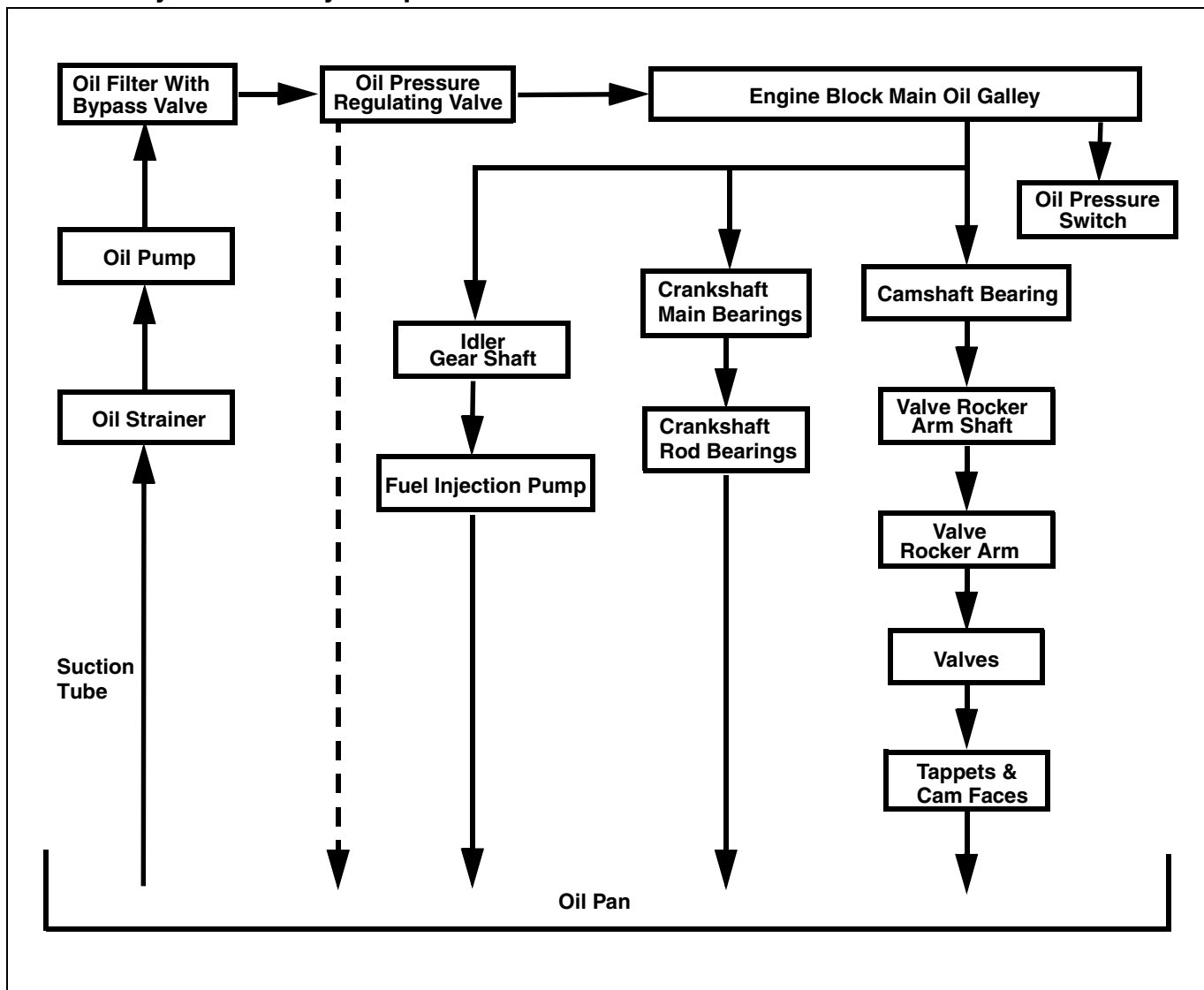

MIF

Function:

A full pressure system lubricates engine parts with clean oil.

Theory of Operation:

The pressure lubrication system consists of a positive displacement gear-driven pump, oil strainer, full flow oil filter, oil pressure regulating valve, and an electrical oil pressure warning switch.

The oil pump is mounted on the front plate of the engine, under the engine front cover, and is driven by the crankshaft. The oil pump draws oil from the oil pan through the strainer and suction tube. The oil is then pumped through an oil passage to the oil filter, oil pressure regulating valve, and through the engine block main oil galley.

From the main oil galley, oil is pushed to the crankshaft main bearing journals and idler gear shaft. Drilled cross-passages in the crankshaft distribute the oil from the main bearings to the connecting rod bearing journals.

Lube oil holes in the main bearing oil grooves send oil through drilled passages to the camshaft bearings.

A drilled passage from the rear camshaft bearing through the cylinder block and cylinder head supplies lubricating oil to the rocker arm shaft. The hollow rocker shaft distributes oil to the rocker arms, tappets and valves.

If oil pressure drops below specification, a pressure switch activates the engine oil pressure light to alert the operator to shut down the engine.

ENGINE - 21 HP DIESEL THEORY OF OPERATION

Fuel System Theory of Operation

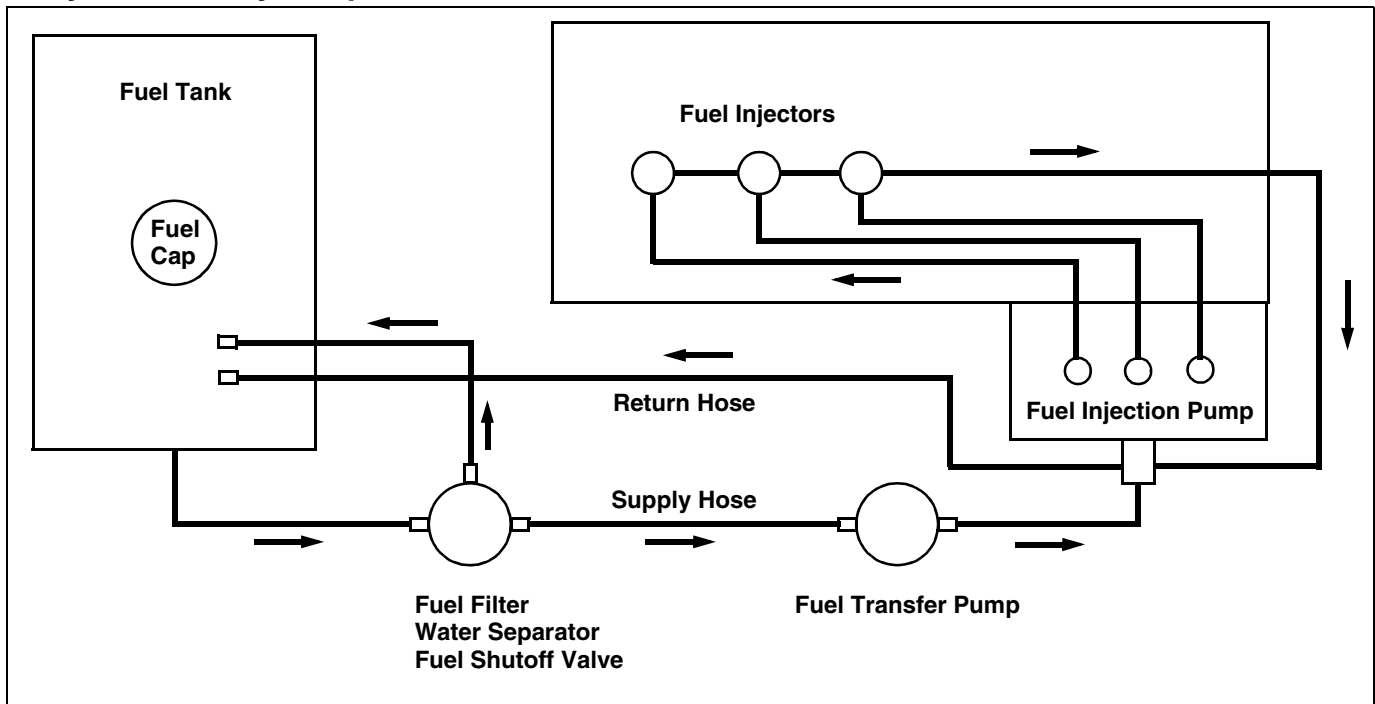

MIF

Function:

The fuel system supplies clean fuel to injection pump and nozzles, and circulates unused fuel back to the tank. An instrument panel mounted electric fuel gauge shows the operator amount of fuel remaining.

Theory of Operation:

Fuel flows from the outlet on the bottom of the tank to the combination glass bowl fuel filter/water separator/fuel shutoff valve. The filter is self priming and excess air is returned to the tank through a return hose. If the fuel valve is on, the engine driven mechanical fuel transfer pump draws fuel from the fuel filter bowl, to the fuel injection pump. After the injection pump housing is full, excess fuel is returned, along with excess leakoff fuel from the injectors, through the return line to the fuel tank.

The engine speed is controlled by the throttle pedal and/or hand throttle lever. The throttle linkage is connected to the injection pump/governor control lever.

The fuel shutoff solenoid controls the flow of fuel inside the injection pump. When the solenoid is energized (ignition key to START position), the solenoid pulls in and allows fuel to be pumped to the injectors. When the key is turned off, return springs on the shutoff shaft, extend the solenoid, moving the shutoff linkage to the shutoff position. The fuel shutoff solenoid stops the flow of fuel inside the fuel injector pump by forcing the governor rack linkage to the NO FUEL position, causing the fuel injector pump to stop supplying fuel to the injectors.

The injection pump meters fuel as determined by the governor and delivers it at high pressure to the injection nozzles. The injection nozzle prevents flow until high pressure is reached, opening the valve and spraying atomized fuel into the pre-combustion swirl chamber. Injection lines have trapped fuel inside whenever injection is not taking place.

A small amount of fuel leaks past the nozzle valve to lubricate the fuel injection nozzle. This leakage combines with excess fuel from the injection pump and is returned to tank. Any air in the fuel system is bled out with return fuel to the fuel tank.

A float-type fuel level sensor mounted on the top of the tank drives a instrument panel mounted gauge, informing the operator of the fuel level.

The fuel shutoff solenoid has two coils inside; one pull-in, and one hold-in coil. The hold-in coil is energized whenever the key switch is in the ON or START position. The pull-in coil is energized only when in the START position and the oil pressure switch closed.

ENGINE - 21 HP DIESEL THEORY OF OPERATION

Air System Theory of Operation

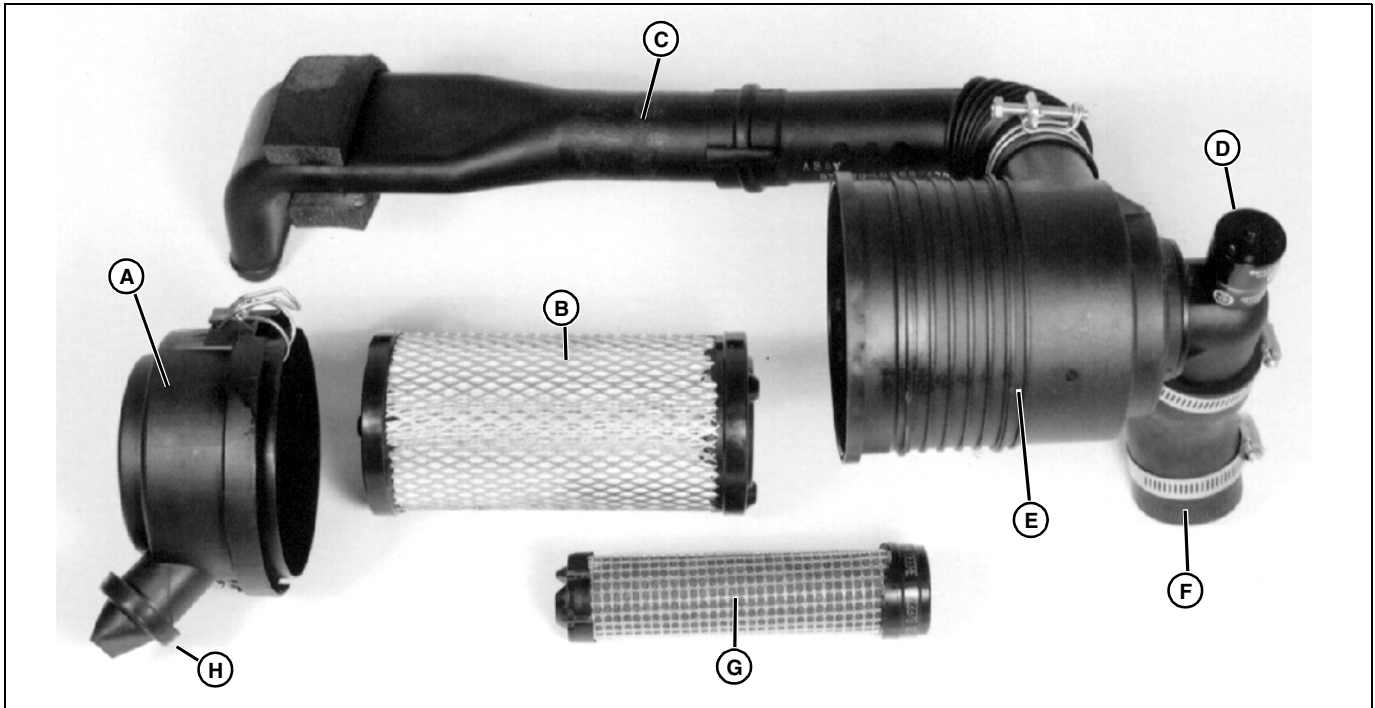

M76971

Function:

The air intake system filters air needed for combustion. The system components include: air inlet tube (C), air cleaner housing (E) and cover (A), unloader valve (H) (and rubber clean-out valve), primary air filter element (B), secondary (or safety) air cleaner element (G), air cleaner restriction indicator (D), outlet tube (F) and clamps.

Theory of Operation:

Air enters the air cleaner inlet tube and into the air cleaner housing, and is directed into the side of a shield. This starts a high-speed centrifugal motion of air which continues around the element until it reaches the far end of the air cleaner housing, to an unloader valve.

Most of the dust is separated from the air by centrifugal force that causes heavy dust particles to enter the opening at the top of the unloader valve. The remaining air enters the primary air filter element. The primary filter element filters the larger dirt particles before the air enters the secondary air filter element. The finer dirt particles are filtered in the secondary air filter before the air enters the intake manifold.

The dirt that is deposited in the unloader valve is removed by the rubber diaphragm at the base of the air cleaner. When the engine is running, a pulsing action is created in the intake system by each intake stroke of the engine. This pulsing action causes the rubber diaphragm to open and close, thus emptying the unloader valve. The operator can squeeze the valve to let the large particles out.

The difference in pressure between the intake manifold and air cleaner is monitored by the Air Cleaner Restriction Indicator. As the air cleaner becomes clogged, and intake manifold vacuum increases, the restriction indicator piston is pulled down against spring tension, and is calibrated to show when it's time to change air cleaner.

ENGINE - 21 HP DIESEL COMPONENT LOCATION

Component Location

Fuel System Component Location

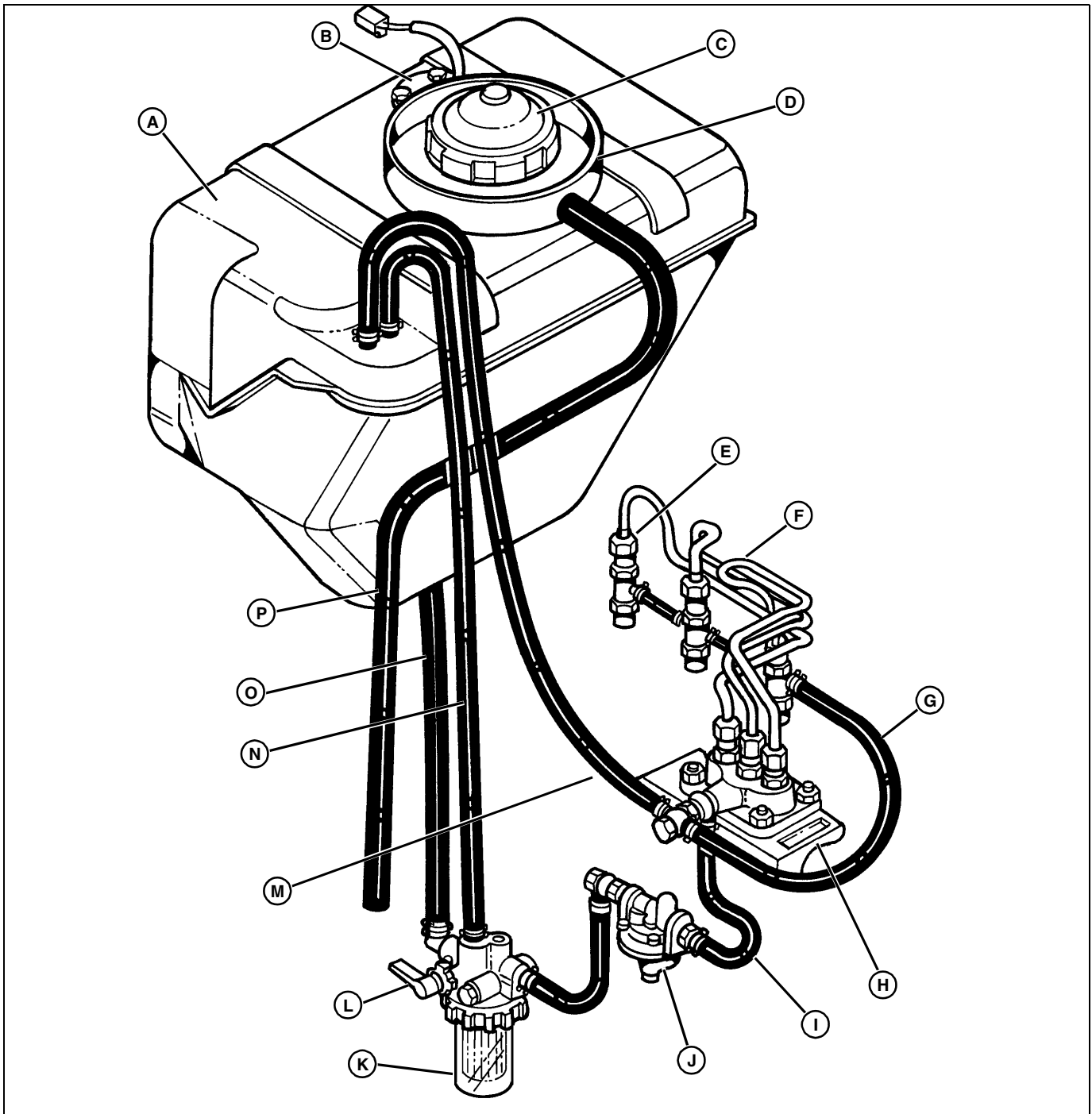

M89983

A - Fuel Tank
B - Fuel Lever Sensor

C - Fuel Filler Cap
D - Fuel Filler Overflow Collar

E - Fuel Injector
F - High Pressure Fuel Injector Lines

G - Fuel Injector Leak-Off Hose

H - Fuel Injector Pump

I - Injection Pump Fuel Supply Line

J - Fuel Transfer Pump

K - Fuel Filter/Water Separator

L - Fuel Shut-Off Valve

M - Fuel Injection Pump Return Hose

N - Fuel Return Hose

O - Fuel Supply Hose

P - Fuel Filler Overflow Hose

ENGINE - 21 HP DIESEL DIAGNOSTICS

Diagnostics

Engine Troubleshooting



CAUTION: Avoid Injury! The engine may start to rotate at any time. Keep hands away from all moving parts when testing.

Coolant in the radiator is extremely hot during operation.

Engine

Symptom: Engine Will Not Start

(1) Proper starting procedure being used is correct for conditions.

Yes - Go to step (2).

No - Use correct procedure for conditions See the Operator's Manual. Go to step (2) if problem continues.

(2) Battery 12.7 VDC or higher?

Yes - Go to step (3).

No - Charge and check battery. See "Battery Voltage and Specific Gravity Test" on page 303. Go to step (3) if problem continues.

(3) No open circuits in wiring?

Yes - Go to step (4).

No - Repair or replace as needed. See "Common Circuit Tests" on page 206. Go to step (4) if problem continues.

(4) Starting motor functioning properly?

Yes - Go to step (5).

No - Repair or replace starting motor. Go to step (5) if problem continues.

(5) Alternator output correct?

Yes - Go to step (6).

No - Repair or replace alternator. Go to step (6) if problem continues.

(6) Engine oil of correct viscosity and type?

Yes - Go to step (7).

No - Replace engine oil with oil of proper viscosity and type. Replace oil filter.

(7) No water in fuel?

Yes - Go to step (8).

Symptom: Engine Will Not Start

No - Drain and replace fuel. Go to step (8) if problem continues.

(8) Fuel filter not clogged?

Yes - Go to step (9).

No - Replace fuel filter. See "Fuel Filter/Water Separator" on page 107. Go to step (9) if problem continues.

(9) No air leak in fuel system?

Yes - Go to step (10).

No - Repair fuel system. Go to step (10) if problem continues.

(10) Fuel lines not plugged, pinched or cracked?

Yes - Go to step (11).

No - Repair or replace fuel lines as needed. Go to step (11) if problem continues.

(11) Correct volume of fuel supplied to injection pump?

Yes - Go to step (12).

No - Replace fuel transfer pump. See "Fuel Transfer Pump" on page 107. Go to step (12) if problem continues.

(12) Intake and/or exhaust valve clearance correct?

Yes - Go to step (13).

No - Adjust valve clearance. Go to step (13) if problem continues.

(13) Timing between injection pump, intake and exhaust valves proper?

Yes - Go to step (14).

No - Adjust valve clearance. Check valve timing. Go to step (14) if problem continues.

(14) Intake and/or exhaust valve not seized?

Yes - Go to step (15).

No - Replace valve and check valve guide. Go to step (15) if problem continues.

(15) Piston rings not broken or seized?

Yes - Go to step (16).

No - Replace rings. Check piston and cylinder. Go to step (16) if problem continues.

(16) Piston rings, piston or cylinder not worn?

Yes - Go to step (17).

ENGINE - 21 HP DIESEL DIAGNOSTICS

Symptom: Engine Will Not Start

No - Replace piston and/or rings, bore or hone cylinder. Go to step (17) if problem continues.

(17) Crankshaft pin or bearing not seized?

Yes - Go to step (1).

No - Regrind crankshaft and replace bearings. Go to step (1) if problem continues.

Symptom: Engine Starts But Does Not Continue Running - No Exhaust Smoke

(1) Engine oil of proper viscosity and type.

Yes - Go to step (2).

No - Replace engine oil filter and oil of proper viscosity and type. Go to step (2) if problem continues.

(2) Fuel filter not clogged?

Yes - Go to step (3).

No - Replace fuel filter. See "Fuel Filter/Water Separator" on page 107. Go to step (3) if problem continues.

(3) No air leak in fuel system?

Yes - Go to step (4).

No - Repair fuel system. Go to step (4) if problem continues.

(4) Fuel lines not plugged, pinched or cracked?

Yes - Go to step (5).

No - Repair or replace fuel lines as needed. Go to step (5) if problem continues.

(5) Correct volume of fuel supplied to injection pump?

Yes - Go to step (6).

No - Replace fuel transfer pump. See "Fuel Transfer Pump" on page 107. Go to step (6) if problem continues.

(6) Valve clearance proper?

Yes - Go to step (7).

No - Adjust valve clearance. Go to step (7) if problem continues.

(7) Crankshaft pin or bearing not seized?

Yes - Go to step (1).

No - Regrind crankshaft and replace bearings. Go to step (1) if problem continues.

Symptom: Engine Starts But Does Not Continue Running - Excess Exhaust Smoke

(1) No water in fuel?

Yes - Go to step (2).

No - Drain and replace fuel. Go to step (2) if problem continues.

(2) Fuel filter not clogged?

Yes - Go to step (3).

No - Replace fuel filter. See "Fuel Filter/Water Separator" on page 107. Go to step (3) if problem continues.

(3) Intake and/or exhaust valve not seized?

Yes - Go to step (4).

No - Replace valve and check valve guide. Go to step (4) if problem continues.

(4) Piston rings not broken or seized?

Yes - Go to step (5).

No - Replace rings. Check piston and cylinder. Go to step (5) if problem continues.

(5) Piston rings, piston or cylinder not worn?

Yes - Go to step (1).

No - Replace piston and/or rings, bore or hone cylinder. Go to step (1) if problem continues.

Symptom: Low Engine Output - Exhaust color NORMAL

(1) Correct type of fuel being used?

Yes - Go to step (2).

No - Drain and replace fuel. Go to step (2) if problem continues.

(2) Proper type and viscosity of oil being used?

Yes - Go to step (3).

No - Replace engine oil and filter. Go to step (3) if problem continues.

(3) Fuel filter not clogged?

Yes - Go to step (4).

No - Replace fuel filter. Go to step (4) if problem continues.

(4) Fuel lines not clogged, cracked or pinched?

Yes - Go to step (5).

ENGINE - 21 HP DIESEL DIAGNOSTICS

Symptom: Low Engine Output - Exhaust color NORMAL

No - Clean or replace fuel lines. Go to step (5) if problem continues.

(5) No air leakage into fuel system?

Yes - Go to step (6).

No - Repair fuel supply system. Go to step (6) if problem continues.

(6) Proper volume of fuel to injection pump?

Yes - Go to step (7).

No - Check or replace fuel transfer pump. Go to step (7) if problem continues.

(7) Intake and exhaust valve clearance correct?

Yes - Go to step (8).

No - Adjust valve clearance. Go to step (8) if problem continues.

(8) Intake or exhaust valves not leaking compression?

Yes - Go to step (9).

No - Grind valves and seats. Go to step (9) if problem continues.

(9) Intake or exhaust valves not seized?

Yes - Go to step (10).

No - Replace valve and check valve guide. Go to step (10) if problem continues.

(10) Cylinder head gasket not leaking compression?

Yes - Go to step (11).

No - Replace head gasket, Resurface head and block if necessary. Go to step (11) if problem continues.

(11) Crankshaft pin or bearing not worn?

Yes - Go to step (1).

No - Grind crankshaft and replace bearings. Go to step (1) if problem continues.

Symptom: Low Engine Output - Exhaust color WHITE

(1) Correct type of fuel?

Yes - Go to step (2).

No - Drain and replace fuel. Go to step (2) if problem continues.

(2) No water in fuel?

Symptom: Low Engine Output - Exhaust color WHITE

Yes - Go to step (3).

No - Drain and replace fuel. Go to step (3) if problem continues.

(3) Even volume of fuel being injected?

Yes - Go to step (4).

No - Repair or replace fuel injector pump or fuel injectors. Go to step (4) if problem continues.

(4) Proper spray pattern from injectors?

Yes - Go to step (5).

No - Clean or replace fuel injector nozzles. Go to step (5) if problem continues.

(5) Intake or exhaust valve stems not worn?

Yes - Go to step (6).

No - Replace valve guides and valves. Go to step (6) if problem continues.

(6) Timing proper between injection pump, intake and exhaust valves?

Yes - Go to step (7).

No - Adjust valve clearance. Go to step (7) if problem continues.

(7) Piston rings installed correctly?

Yes - Go to step (8).

No - Install piston rings correctly. Go to step (8) if problem continues.

(8) Piston ring ends staggered?

Yes - Go to step (9).

No - Stagger piston ring ends. Go to step (9) if problem continues.

(9) Piston, rings, or cylinder not worn?

Yes - Go to step (10).

No - Replace pistons and rings, bore or hone cylinders. Go to step (10) if problem continues.

(10) Piston rings not broken or seized?

Yes - Go to step (1).

No - Replace rings. Replace pistons if damaged. Bore cylinder if damaged. Go to step (1) if problem continues.

ENGINE - 21 HP DIESEL DIAGNOSTICS

Symptom: Low Engine Output - Exhaust color BLACK

(1) Correct type of fuel?

Yes - Go to step (2).

No - Drain and replace fuel. Go to step (2) if problem continues.

(2) Air filter elements not clogged?

Yes - Go to step (3).

No - Clean or replace air filter elements. Go to step (3) if problem continues.

(3) Exhaust pipe not clogged?

Yes - Go to step (4).

No - Clean exhaust pipe. Go to step (4) if problem continues.

(4) Engine running cool enough?

Yes - Go to step (5).

No - Check thermostat, replace if faulty. Adjust fan belt tension. Go to step (5) if problem continues.

(5) Cooling system filled to correct level?

Yes - Go to step (6).

No - Check for leaks and fill system to correct level. Go to step (6) if problem continues.

(6) Correct volume of fuel being injected?

Yes - Go to step (7).

No - Replace faulty fuel injector pump or fuel injectors. Go to step (7) if problem continues.

(7) Correct pattern from fuel injectors?

Yes - Go to step (8).

No - Clean or replace fuel injector nozzles. Go to step (8) if problem continues.

(8) Proper timing between injection pump, intake and exhaust valves?

Yes - Go to step (9).

No - Adjust valve clearance. Go to step (9) if problem continues.

(9) Intake or exhaust valves not leaking compression?

Yes - Go to step (10).

No - Grind valves and seats. Go to step (10) if problem continues.

(10) Intake or exhaust valve not seized?

Symptom: Low Engine Output - Exhaust color BLACK

Yes - Go to step (11).

No - Replace valve and check valve guide. Go to step (11) if problem continues.

(11) Engine being run under high altitude or high temperature conditions.

Symptom: Exhaust color WHITE under load

(1) Correct type of fuel?

Yes - Go to step (2).

No - Drain and replace fuel. Go to step (2) if problem continues.

(2) No water in fuel?

Yes - Go to step (3).

No - Drain and replace fuel. Go to step (3) if problem continues.

(3) Engine not running too cool?

Yes - Go to step (4).

No - Check thermostat, replace if faulty. Go to step (4) if problem continues.

(4) Correct volume of fuel being injected?

Yes - Go to step (5).

No - Replace faulty fuel injector pump or fuel injectors. Go to step (5) if problem continues.

(5) Correct pattern from fuel injectors?

Yes - Go to step (6).

No - Clean or replace fuel injector nozzles. Go to step (6) if problem continues.

(6) Proper timing between injection pump, intake and exhaust valves?

Yes - Go to step (7).

No - Adjust valve clearance. Go to step (7) if problem continues.

(7) Piston rings installed correctly?

Yes - Go to step (8).

No - Install piston rings correctly. Go to step (8) if problem continues.

(8) Piston, rings or cylinder not worn?

Yes - Go to step (9).

ENGINE - 21 HP DIESEL DIAGNOSTICS

Symptom: Exhaust color **WHITE** under load

No - Replace pistons and rings, bore or hone cylinders. Go to step (9) if problem continues.

(9) Piston rings not broken or seized?

Yes - Go to step (1).

No - Replace rings. Check pistons and cylinders. Go to step (1) if problem continues.

Symptom: Exhaust color **BLACK** under load

(1) Correct type of fuel?

Yes - Go to step (2).

No - Drain and replace fuel. Go to step (2) if problem continues.

(2) Air filter elements not clogged?

Yes - Go to step (3).

No - Clean or replace air filter elements. Go to step (3) if problem continues.

(3) Exhaust pipe not clogged?

Yes - Go to step (4).

No - Clean exhaust pipe. Go to step (4) if problem continues.

(4) Even volume of fuel being injected?

Yes - Go to step (5).

No - Repair or replace fuel injector pump or fuel injectors. Go to step (5) if problem continues.

(5) Correct volume of fuel being injected?

Yes - Go to step (6).

No - Replace faulty fuel injector pump or fuel injectors. Go to step (6) if problem continues.

(6) Proper spray pattern from injectors?

Yes - Go to step (7).

No - Clean or replace fuel injector nozzles. Go to step (7) if problem continues.

(7) Timing proper between injection pump, intake and exhaust valves?

Yes - Go to step (8).

No - Adjust valve clearance. Go to step (8) if problem continues.

(8) Intake or exhaust valves not leaking compression?

Yes - Go to step (9).

Symptom: Exhaust color **BLACK** under load

No - Grind valves and seats. Go to step (9) if problem continues.

(9) Intake or exhaust valves not seized?

Yes - Go to step (10).

No - Replace valve and check valve guide. Go to step (10) if problem continues.

(10) Engine being run under high altitude or high temperature conditions?

Symptom: Exhaust temperature too high

(1) Cooling system filled to correct level?

Yes - Go to step (2).

No - Check for leaks and fill system to correct level. Go to step (2) if problem continues.

(2) Engine running cool enough?

Yes - Go to step (3).

No - Check thermostat, replace if faulty. Adjust fan belt tension. Go to step (3) if problem continues.

(3) Exhaust pipe not clogged?

Yes - Go to step (4).

No - Clean exhaust pipe. Go to step (4) if problem continues.

(4) Even volume of fuel being injected?

Yes - Go to step (5).

No - Repair or replace fuel injector pump or fuel injectors. Go to step (5) if problem continues.

(5) Correct volume of fuel being injected?

Yes - Go to step (6).

No - Replace faulty fuel injector pump or fuel injectors. Go to step (6) if problem continues.

(6) Intake or exhaust valve clearance correct?

Yes - Go to step (7).

No - Adjust valve clearance. Go to step (7) if problem continues.

(7) Intake or exhaust valves not leaking compression?

Yes - Go to step (8).

No - Grind valves and seats. Go to step (8) if problem continues.

(8) Piston rings not broken or seized?

ENGINE - 21 HP DIESEL DIAGNOSTICS

Symptom: Exhaust temperature too high

Yes - Go to step (1).

No - Replace rings. Replace pistons if damaged. Bole cylinder if damaged. Go to step (1) if problem continues.

Symptom: Engine Runs Rough - Misfiring

(1) Intake or exhaust valve clearance correct?

Yes - Go to step (2).

No - Adjust valve clearance. Go to step (2) if problem continues.

(2) Timing between injection pump, intake and exhaust valves proper?

Yes - Go to step (3).

No - Adjust valve clearance. Check valve timing. Go to step (3) if problem continues.

(3) Backlash of timing gear not excessive?

Yes - Go to step (4).

No - Repair gears as needed. Go to step (4) if problem continues.

(4) Combustion chambers clean of foreign matter?

Yes - Go to step (5).

No - Clean combustion chambers. Go to step (5) if problem continues.

(5) Intake or exhaust valves not leaking compression?

Yes - Go to step (6).

No - Grind valves and seats. Go to step (6) if problem continues.

(6) Intake or exhaust valves not seized?

Yes - Go to step (7).

No - Replace valves and check valve guide. Go to step (7) if problem continues.

(7) Piston rings not broken or seized?

Yes - Go to step (8).

No - Replace rings, Check pistons and cylinders. Go to step (8) if problem continues.

(8) Crankshaft pin or bearing not worn or seized?

Yes - Go to step (9).

No - Grind crankshaft and replace bearings. Go to step (9) if problem continues.

(9) Connecting rod bolts torqued properly?

Symptom: Engine Runs Rough - Misfiring

Yes - Go to step (1).

No - Replace damaged components. Torque to correct specification. Go to step (1) if problem continues.

Symptom: Engine Runs Rough - Uneven combustion sound

(1) Correct type of fuel being used?

Yes - Go to step (2).

No - Drain and replace fuel. Go to step (2) if problem continues.

(2) No water in fuel?

Yes - Go to step (3).

No - Drain and replace fuel. Go to step (3) if problem continues.

(3) Even volume of fuel being injected?

Yes - Go to step (4).

No - Repair or replace fuel injector pump and fuel injectors. Go to step (4) if problem continues.

(4) Proper spray pattern from injectors?

Yes - Go to step (5).

No - Clean or replace fuel injector nozzles. Go to step (5) if problem continues.

(5) Air filter elements not clogged?

Yes - Go to step (6).

No - Clean or replace air filter elements. Go to step (6) if problem continues.

(6) Exhaust pipe not clogged?

Yes - Go to step (1).

No - Clean exhaust pipe. Go to step (1) if problem continues.

Symptom: Engine Runs Rough - Engine surges DURING IDLING

(1) No water in fuel?

Yes - Go to step (2).

No - Drain and replace fuel. Go to step (2) if problem continues.

(2) Even volume of fuel injected?

Yes - Go to step (3).

ENGINE - 21 HP DIESEL DIAGNOSTICS

Symptom: Engine Runs Rough - Engine surges DURING IDLING

No - Repair or replace fuel injector pump and fuel injectors. Go to step (3) if problem continues.

(3) Proper spray pattern from injectors?

Yes - Go to step (4).

No - Clean or replace fuel injector nozzles. Go to step (4) if problem continues.

(4) Piston rings not broken or seized?

Yes - Go to step (5).

No - Replace rings, Check pistons and cylinders. Go to step (5) if problem continues.

(5) Crankshaft pin or bearing not worn or seized?

Yes - Go to step (1).

No - Grind crankshaft and replace bearings. Go to step (1) if problem continues.

Symptom: Engine Runs Rough - Engine surges UNDER LOAD

(1) No water in fuel?

Yes - Go to step (2).

No - Drain and replace fuel. Go to step (2) if problem continues.

(2) Even volume of fuel injected?

Yes - Go to step (3).

No - Repair or replace fuel injector pump and fuel injectors. Go to step (3) if problem continues.

(3) Proper spray pattern from injectors?

Yes - Go to step (4).

No - Clean or replace fuel injector nozzles. Go to step (4) if problem continues.

(4) Piston rings not broken or seized?

Yes - Go to step (5).

No - Replace rings, Check pistons and cylinders. Go to step (5) if problem continues.

(5) Crankshaft pin or bearing not worn or seized?

Yes - Go to step (1).

No - Grind crankshaft and replace bearings. Go to step (1) if problem continues.

Symptom: Engine Runs Rough - Excessive Engine Vibration

(1) Even volume of fuel injected?

Yes - Go to step (2).

No - Repair or replace fuel injector pump and fuel injectors. Go to step (2) if problem continues.

(2) Proper spray pattern from injectors?

Yes - Go to step (3).

No - Clean or replace fuel injector nozzles. Go to step (3) if problem continues.

(3) Piston rings not broken or seized?

Yes - Go to step (4).

No - Replace rings, Check pistons and cylinders. Go to step (4) if problem continues.

(4) Crankshaft pin or bearing not worn or seized?

Yes - Go to step (5).

No - Grind crankshaft and replace bearings. Go to step (5) if problem continues.

(5) Connecting rod bolts torqued properly?

Yes - Go to step (1).

No - Replace damaged components. Torque to correct specification. Go to step (1) if problem continues.

Symptom: Engine Runs Rough - Poor return to low speed

(1) Go to steps procedures for "Engine Runs Rough".

Fuel Consumption

Symptom: Excessive Fuel Consumption

(1) Engine not running too cool?

Yes - Go to step (2).

No - Check thermostat, replace if faulty. Go to step (2) if problem continues.

(2) Correct volume of fuel being injected?

Yes - Go to step (3).

No - Replace faulty fuel injector pump or fuel injectors. Go to step (3) if problem continues.

(3) Correct pattern from fuel injectors?

Yes - Go to step (4).

ENGINE - 21 HP DIESEL DIAGNOSTICS

Symptom: Excessive Fuel Consumption

No - Clean or replace fuel injector nozzles. Go to step (4) if problem continues.

(4) Intake or exhaust valves not leaking compression?

Yes - Go to step (1).

No - Grind valves and seats. Go to step (1) if problem continues.

Lubrication

Symptom: Excessive oil consumption

(1) Engine oil of correct viscosity and type?

Yes - Go to step (2).

No - Replace engine oil with oil of proper viscosity and type. Replace oil filter. Go to step (2) if problem continues.

(2) No external or internal oil leak?

Yes - Go to step (3).

No - Repair as needed. Go to step (3) if problem continues.

(3) Intake or exhaust valve stems not worn?

Yes - Go to step (4).

No - Replace valve guides and valves. Go to step (4) if problem continues.

(4) Piston rings installed correctly?

Yes - Go to step (5).

No - Install piston rings correctly. Go to step (5) if problem continues.

(5) Piston ring ends staggered?

Yes - Go to step (6).

No - Stagger piston ring ends. Go to step (6) if problem continues.

(6) Piston, rings or cylinder not worn?

Yes - Go to step (7).

No - Replace pistons and rings, bore or hone cylinders. Go to step (7) if problem continues.

(7) Piston rings not broken or seized?

Yes - Go to step (8).

No - Replace rings. Check pistons and cylinders. Go to step (8) if problem continues.

(8) No foreign matter in combustion chamber?

Symptom: Excessive oil consumption

Yes - Go to step (1).

No - Clean head and top of piston. Check for damage. Go to step (1) if problem continues.

Symptom: Fuel oil in crankcase

(1) Correct volume of fuel being injected?

Yes - Go to step (2).

No - Replace faulty fuel injector pump or fuel injectors. Go to step (2) if problem continues.

(2) Intake or exhaust valve not seized or broken?

Yes - Go to step (3).

No - Replace valve and check valve guide. Go to step (3) if problem continues.

(3) Piston rings not broken or seized?

Yes - Go to step (4).

No - Replace rings and check pistons and cylinders. Go to step (4) if problem continues.

(4) Piston rings, piston or cylinder not worn?

Yes - Go to step (1).

No - Replace piston and or rings. Bore or hone cylinder. Go to step (1) if problem continues.

Symptom: Water in crankcase

(1) Cylinder head gasket not leaking?

Yes - Go to step (2).

No - Replace head gasket, Resurface head and block if necessary. Go to step (2) if problem continues.

(2) Water jacket not cracked?

Yes - Go to step (1).

No - Repair or replace water jacket. Go to step (1) if problem continues.

Symptom: Low oil pressure

(1) Oil at correct level?

Yes - Go to step (2).

No - Add oil. Go to step (2) if problem continues.

(2) Engine oil of correct viscosity and type?

Yes - Go to step (3).

No - Replace engine oil with oil of proper viscosity and type. Replace oil filter. Go to step (3) if problem continues.

ENGINE - 21 HP DIESEL DIAGNOSTICS

Symptom: Low oil pressure

(3) No external or internal oil leak?

Yes - Go to step (4).

No - Repair as needed. Go to step (4) if problem continues.

(4) Oil filter not clogged.

Yes - Go to step (5).

No - Replace oil filter and oil. Go to step (5) if problem continues.

(5) Oil pressure relief valve not worn or damaged?

Yes - Go to step (6).

No - Clean, adjust or replace relief valve. Go to step (6) if problem continues.

(6) Crankshaft pin or bearing not worn?

Yes - Go to step (7).

No - Grind crankshaft and replace bearings. Go to step (7) if problem continues.

(7) Connecting rod bolts torqued properly?

Yes - Go to step (8).

No - Replace damaged components. Torque to correct specification. Go to step (8) if problem continues.

(8) Water jacket not cracked?

Yes - Go to step (1).

No - Repair or replace water jacket. Go to step (1) if problem continues.

Coolant

Symptom: Overheating

(1) Cooling system filled to correct level?

Yes - Go to step (2).

No - Check for leaks and fill system to correct level. Go to step (2) if problem continues.

(2) Engine running cool enough?

Yes - Go to step (3).

No - Check thermostat, replace if faulty. Adjust fan belt tension. Go to step (3) if problem continues.

(3) Correct volume of fuel being injected?

Yes - Go to step (4).

No - Replace faulty fuel injector pump or fuel injectors. Go to step (4) if problem continues.

Symptom: Overheating

(4) Cylinder head gasket not leaking?

Yes - Go to step (5).

No - Replace head gasket, Resurface head and block if necessary. Go to step (5) if problem continues.

(5) Piston rings not broken or seized?

Yes - Go to step (6).

No - Replace rings. Check pistons and cylinders. Go to step (6) if problem continues.

(6) Water jacket not cracked?

Yes - Go to step (7).

No - Repair or replace water jacket. Go to step (7) if problem continues.

(7) Engine being run under high altitude or high temperature conditions.

Symptom: Low water temperature

(1) Thermostat is operating correctly?

No - Replace thermostat.

Compression

Symptom: Low compression

(1) Engine oil of correct viscosity and type?

Yes - Go to step (2).

No - Replace engine oil of correct viscosity and type. Replace oil filter. Go to step (2) if problem continues.

(2) Oil filter not clogged?

Yes - Go to step (3).

No - Replace oil filter. Go to step (3) if problem continues.

(3) Correct volume of fuel being injected?

Yes - Go to step (4).

No - Replace faulty fuel injector pump or fuel injectors. Go to step (4) if problem continues.

(4) Intake or exhaust valves not leaking compression?

Yes - Go to step (5).

No - Grind valves and seats. Go to step (5) if problem continues.

(5) Intake or exhaust valve stems not worn?

Yes - Go to step (6).

ENGINE - 21 HP DIESEL DIAGNOSTICS

Symptom: Low compression

No - Replace valve guides and valves. Go to step (6) if problem continues.

(6) No foreign matter in combustion chamber?

Yes - Go to step (7).

No - Clean head and top of piston. Check for damage. Go to step (7) if problem continues.

(7) Intake or exhaust valve not seized?

Yes - Go to step (8).

No - Replace valve and check valve guide. Go to step (8) if problem continues.

(8) Piston rings not broken or seized?

Yes - Go to step (9).

No - Replace rings. Check pistons and cylinders. Go to step (9) if problem continues.

(9) Piston, rings or cylinder not worn?

Yes - Go to step (10).

No - Replace pistons and rings, bore or hone cylinders. Go to step (10) if problem continues.

(10) Crankshaft pin or bearing not worn?

Yes - Go to step (11).

No - Grind crankshaft and replace bearings. Go to step (11) if problem continues.

(11) Piston rings installed correctly?

Yes - Go to step (12).

No - Install piston rings correctly. Go to step (12) if problem continues.

(12) Piston ring ends staggered?

Yes - Go to step (1).

No - Stagger piston ring ends. Go to step (1) if problem continues.

Symptom: Intake Manifold Pressure Low

(1) Air filter elements not clogged?

Yes - Go to step (2).

No - Clean or replace air filter elements. Go to step (2) if problem continues.

(2) Intake or exhaust valve clearance correct?

Yes - Go to step (3).

No - Adjust valve clearance. Go to step (3) if problem continues.

Symptom: Intake Manifold Pressure Low

(3) Intake or exhaust valve not seized?

Yes - Go to step (4).

No - Replace valve and check valve guide. Go to step (4) if problem continues.

(4) Engine being run under high altitude or high temperature conditions.

Symptom: Intake Manifold Pressure High pressure

(1) Correct volume of fuel being injected?

No - Replace faulty fuel injector pump or fuel injectors.

ENGINE - 21 HP DIESEL TESTS AND ADJUSTMENTS

Tests and Adjustments

Cylinder Compression Test

Reason:

To determine the condition of the pistons, rings, cylinder walls and valves.

Equipment:

- JT01682 Compression Gauge Assembly
- JDG472 Adapter

Procedure:

1. Run engine for 5 minutes to bring to operating temperature. Stop engine.
2. Remove injection nozzles.

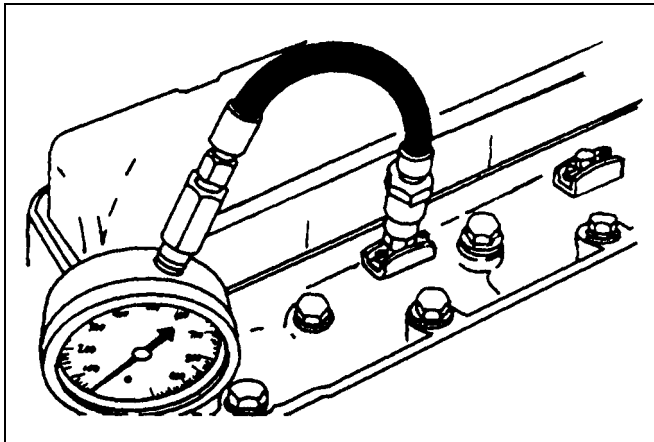

T6333EU

3. Remove heat protector from end of fuel injection nozzle, and install on JDG472 adapter.
4. Install JT01682 Compression Gauge Assembly and JDG472 Adapter in injection port.
5. Disconnect fuel shutoff solenoid electrical connector on rear of governor.

IMPORTANT: Avoid damage! DO NOT overheat starting motor during test.

6. Crank engine for three seconds with starting motor.
7. Record pressure reading for each cylinder.

Compression Pressure Specifications:

Standard	3432 kPa (498 psi)
Minimum Pressure	2746 kPa (398 psi)
Maximum Difference Between Cylinders	245 kPa (36 psi)
Minimum Cranking Speed	250 rpm

NOTE: Pressure listed is for 300 meters (1000 ft) above sea level. Reduce specification an additional 4% for each 300 meters (1000 ft) of altitude above this level.

Results:

- If pressure reading is below specification, squirt clean engine oil into cylinders through injector ports and repeat test.
- If pressure increases significantly, check piston, rings, and cylinder walls for wear or damage.
- If pressure does not increase significantly after retest, check for leaking valves, valve seats or cylinder head gasket.

Throttle Adjustment

Reason:

To ensure that throttle hand lever linkage, and foot pedal linkage (Gear Transmission Only), is adjusted correctly, and to allow to full high idle and slow idle position of governor throttle lever.

Equipment:

- (2) 12 mm Open End Wrenches

Procedure:

1. Park machine on level surface, turn key switch OFF, shift transmission to NEUTRAL, and LOCK park brake.
2. Open hood and remove right side engine cover.
3. Gear Transmission: Loosen lock nut and back-off throttle pedal stop screw under right side foot rest panel.
4. Pull throttle hand control lever fully back to slow idle position.

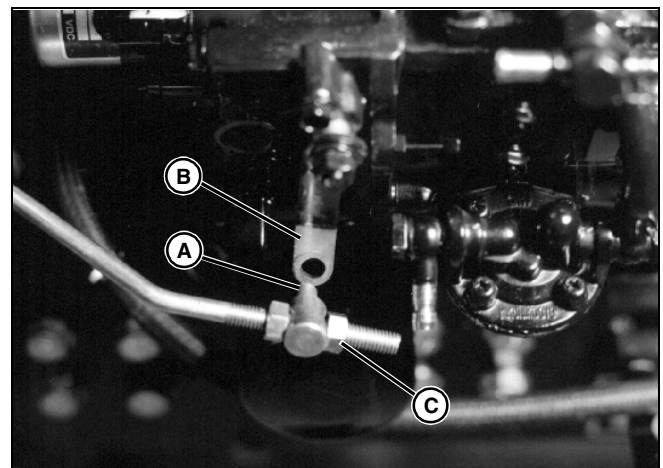

M76972

5. Remove spring pin and washer from back of throttle adjustment pin (A), and pull pin from governor lever (B).

ENGINE - 21 HP DIESEL TESTS AND ADJUSTMENTS

6. Check alignment of adjustment pin to hole in governor lever. Pin should slide into hole easily. If not, loosen locking nuts (C) on throttle rod, and thread adjustment pin forward or back until aligned with hole in governor throttle lever.
7. Tighten locking nuts on throttle shaft.
8. Push throttle hand control lever forward to fast idle position. Move governor throttle lever rearward by hand to full throttle stop position.
9. Check alignment of throttle adjustment pin with hole in governor throttle lever. Readjust pin if necessary to achieve full fast idle position.
10. Install washer and spring clip onto throttle rod adjusting pin shaft.
11. Move throttle hand control lever to full forward (fast idle) position.
12. Gear Transmission: Turn stop bolt on throttle pedal until it contacts frame. Tighten lock nut. Throttle foot pedal should reach stop at same time as governor throttle lever reaches fast idle stop, with no strain on governor internal components.
- Hydrostatic Transmission: Turn stop bolt on throttle hand control lever until it contacts lever. Tighten lock nut. Throttle hand control should reach stop at same time as governor throttle lever reaches fast idle stop, with no strain on governor internal components.
13. Install engine side cover and close hood.

Slow Idle Adjustment

IMPORTANT: Avoid damage! The slow idle adjustment is the only adjustment that can be made on this engine.

The fast idle and torque capsule adjustments are pre-set by the engine manufacturer to comply with strict EPA/ARB emissions requirements, and are adjustable ONLY by authorized diesel service facilities.

Reason:

To achieve proper slow idle rpm setting. Provides adequate rpm to keep engine running smoothly without stalling.

Equipment:

- JT05719 Digital Strobe Tachometer
- (2) 10 mm Box End Wrenches

Procedure:

1. Place a small piece of reflective tape on outside edge of crankshaft pulley.

2. Start engine and run for five minutes until thermostat opens.

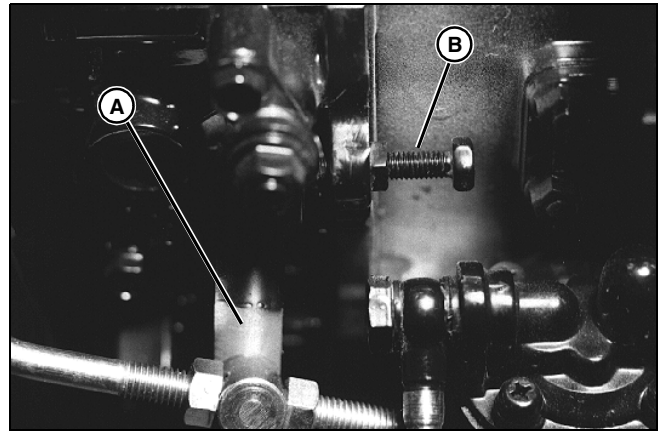

M76978

3. Move throttle hand lever fully back to low idle position. Check that governor throttle lever (A) is against slow idle stop screw (B). If not, adjust throttle linkage, see "Throttle Adjustment" in this section).
4. Use JT05719 Hand Held Digital Tachometer to check engine speed at front crankshaft pulley.

Specifications:

Slow Idle Speed 1000 ± 25 rpm

- If slow idle rpm is not according to specifications, loosen lock nut and adjust slow idle stop screw. After adjustment, tighten lock nut, and recheck engine slow idle speed.

Valve Clearance Adjustment

Reason:

To maintain proper clearance between valves and rocker arms for maximum compression and valve train life.

Equipment:

- Feeler Gauge
- 10 mm End Wrench
- Flat Blade Screwdriver
- 17 mm Wrench

Procedure:

1. Engine must be cool (room temperature) before valve clearance is checked.
2. Be sure ignition key is OFF before attempting to turn engine by hand.
3. Open hood and remove engine side covers. See "Side Panels, Removal and Installation" on page 679 of Miscellaneous section.

ENGINE - 21 HP DIESEL TESTS AND ADJUSTMENTS

4. Remove rocker arm cover. See "Rocker Arm Cover Removal and Installation" on page 62.

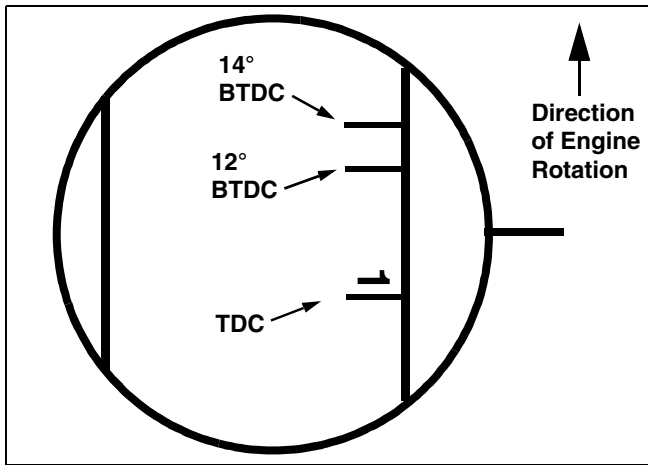

MIF

5. Locate the rubber dust plug on the right side of the transmission tunnel, under the right side operator's foot support. Pry the dust plug from the tunnel with a pry bar. The flywheel can be seen inside the inspection hole.

NOTE: "Top Dead Center (TDC)" is when the piston is at its highest point of travel in the cylinder on the compression stroke. Number one cylinder is located at rear of engine (flywheel side).

6. Using a 17 mm wrench, turn the crankshaft pulley while watching the flywheel inside the inspection hole. Align the number one TDC mark on the flywheel with the pointer on the tunnel.

NOTE: When top dead center is reached, the rocker arms for that cylinder will be motionless as the crankshaft is rotated. If rocker arms are still moving when TDC is approached, rotate crankshaft one full revolution and try again.

7. Try to move rocker arms and/or push rods for No. 1 cylinder:

- If rocker arm and push rod are loose, the piston is at TDC on the compression stroke and you may proceed to step 8.
- If rocker arms and/or push rods are not loose, rotate flywheel one revolution (360°), and recheck rocker arm and push rods.

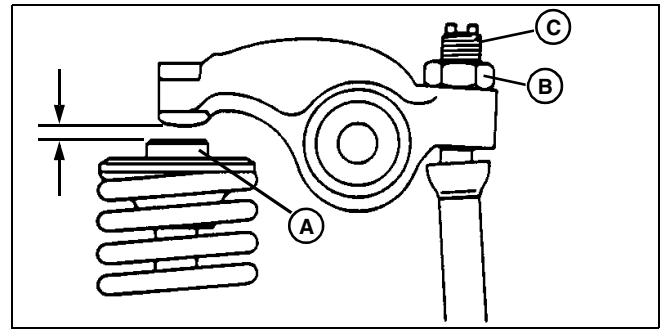

rocker

8. Slide feeler gauge between valve cap (A) and rocker arm to measure clearance.

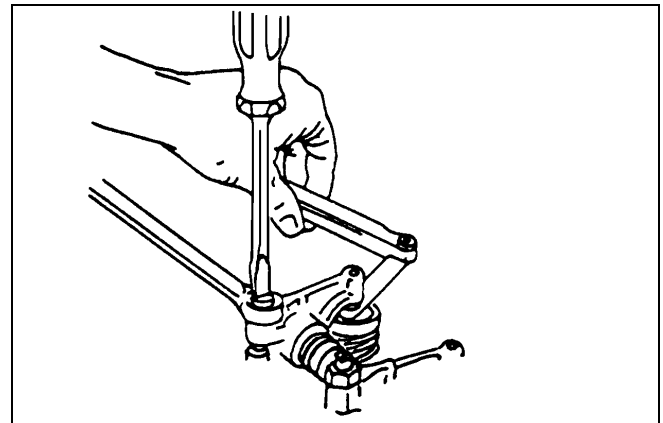

T6105BF

9. To adjust valves, loosen lock nut (B) and turn adjusting screw (C) until blade of feeler gauge can be inserted between rocker arm and valve cap. Hold adjusting screw while tightening lock nut.

10. Recheck valve clearance after tightening lock nut.

Specification:

Valve Clearance 0.15 - 0.25 mm (0.006 - 0.010 in.)



valve cap

11. Check that valve cap on end of valve stem remained seated on valve and inside valve spring retainer.

12. Turn crankshaft pulley counter clockwise (as viewed from operator's seat or flywheel end) approximately 2/3 of a revolution (240°) while watching observation hole for number three timing mark.

13. Check rocker arms and push rods for cylinder number three are loose.

14. Repeat steps 7 - 13 for number three cylinder.

15. Repeat steps 7 - 11 for number two cylinder.

ENGINE - 21 HP DIESEL TESTS AND ADJUSTMENTS

16. Replace rocker arm cover, air cleaner bracket and housing, muffler, and inspection hole dust cover.

17. Replace engine side covers and hood.

Valve Lift Check

Reason:

To test for excessive wear on camshaft lobes, cam followers, rocker arms, valve stems, valve caps, or bent push rods.

Equipment:

- Dial Indicator with magnetic base

Procedure:

1. Remove rocker arm cover.
2. Check that valve clearance is within specification. Adjust if necessary.

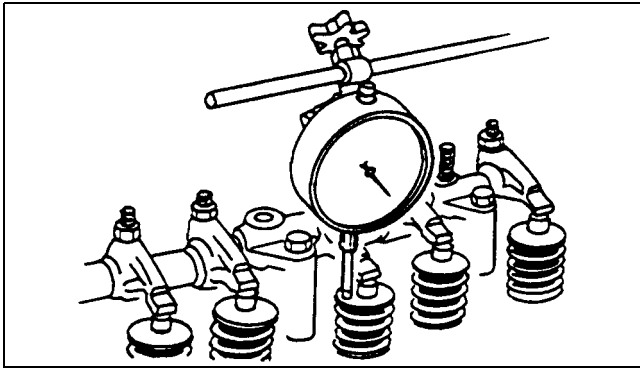

T6333DT

3. Fasten dial indicator to engine and position indicator tip on valve retainer. Valve must be fully closed and rocker arm must move freely.

4. Zero the dial indicator.

5. Rotate crankshaft while observing dial indicator as valve is moved to the full open (down) position.

Specification:

Valve Lift 7.5 mm (0.300 in.)

6. Repeat for each valve.

Results:

- If valve lift is less than specification, remove and inspect camshaft, camshaft followers, push rods, valve caps and stems, and/or rocker arms for wear or damage.

Fuel Injection System Tests



CAUTION: Avoid Injury! Escaping fluid under pressure can penetrate the skin causing serious injury. Avoid the hazard by relieving pressure before disconnecting high pressure lines. Tighten all connections before applying pressure. Search for leaks with a piece of cardboard. Protect hands and body from high pressure fluids.

If an accident occurs, see a doctor immediately. Any fluid injected into the skin must be surgically removed within a few hours or gangrene may result. Doctors unfamiliar with this type of injury should reference a knowledgeable source. Such information is available from the Deere & Company Medical Department in Moline, Illinois, U.S.A.

Reason:

To stop fuel flow to the cylinders (one at a time), while engine is running, to determine what effect that cylinder has on overall engine performance.

Equipment:

- (2) 17 mm Open End Wrenches

Procedure:

1. Park machine on level surface, park brake locked, transmission in NEUTRAL, power-take-off OFF.
2. Open hood and remove engine side covers, air cleaner, coolant overflow tank and mounting bracket



CAUTION: Avoid Injury! This test will cause diesel fuel to be released from fuel system. Injection pump is capable of producing extremely high pressure. Eye protection must be worn. Do not open fuel injector connectors more than 1/8 of a turn. Do not place hands near injectors during test. Do not allow any debris to enter intake manifold during test. Do not smoke.

3. Start engine and run at slow idle.

ENGINE - 24 HP DIESEL TABLE OF CONTENTS

Table of Contents	Repair	151
	Engine Removal and Installation	151
	Front Sub-Frame	
	Removal and Installation	156
	Rocker Cover Removal and Installation	157
	Rocker Arm Assembly	157
	Cylinder Head and Valves	
	Removal and Installation	159
	Cylinder Head and Valves	
	Disassembly and Assembly.....	160
	Valve Seats.....	161
	Valve Recession.....	162
	Valve Guides	163
	Valve Springs.....	163
	Exhaust Manifold	164
	Intake Manifold	164
	Grind Valve Seats.....	164
	Lap Valves.....	165
	Piston and Connecting Rod.....	165
	Piston Inspection	168
	Cylinder Bore.....	171
	Crankshaft Rear Oil Seal	173
	Crankshaft Front Oil Seal	173
	Crankshaft and Main Bearings	173
	Flywheel and Coupling	176
	Camshaft	177
	Camshaft Followers	180
	Timing Gear Cover	181
	Idler Gear.....	182
	Timing Gear Cover Mounting Plate	183
	Oil Pan and Strainer	183
	Oil Pump.....	183
	Thermostat and Water Pump.....	185
	Fuel Filter Assembly	186
	Component Location - Fuel Supply	187
	Fuel Injection Pump.....	188
	Fuel Injection Nozzles.....	190
	Starting Motor Removal and Installation....	192
	Starting Motor Disassembly and Assembly	193
	Starting Motor Inspection and Test.....	195
	Starting Motor Gear Train	196
	Starting Motor Solenoid	198
	20 Amp Alternator.....	199
Specifications	119	
General.....	119	
Repair Specifications.....	119	
Tests and Adjustment Specifications	123	
Operational Tests	123	
Torque Values, Non-Standard Fasteners...	124	
Special Tools.....	124	
Other Materials.....	124	
Theory of Operation	125	
Fuel and Air System Operation	125	
Cooling System Operation	126	
Lubrication System Operation.....	127	
Diagnostics	128	
Engine Troubleshooting	128	
Tests and Adjustments	138	
Cylinder Compression Test	138	
Slow Idle Adjustment.....	138	
Valve Clearance Adjustment.....	139	
Valve Lift Check	140	
Fuel Injection System Tests	141	
Fuel Injection Nozzle Test.....	142	
Injection Pump Timing (EPA Engines)	143	
Connecting Rod Side Play Check	143	
Connecting Rod Bearing		
Clearance Check.....	144	
Crankshaft End Play Check	145	
Crankshaft Main Bearing		
Clearance Check.....	145	
Camshaft End Play Check	146	
Timing Gear Backlash Check.....	146	
Thermostat Opening Test.....	147	
Fan/Alternator Drive Belt Adjustment	147	
Radiator Bubble Test.....	147	
Cooling System Pressure Test.....	148	
Radiator Pressure Cap Test.....	148	
Engine Oil Pressure Test	149	
Fuel Transfer Pump Tests.....	149	
Fuel System Leakage Test.....	150	
Bleed Fuel System	150	

ENGINE - 24 HP DIESEL TABLE OF CONTENTS



ENGINE - 24 HP DIESEL SPECIFICATIONS

Specifications

General

Make	Yanmar
Model 4115	3TNE78A
Type	4-Cycle Diesel
Gross Power @ 2650 rpm	17.9 kW (24.0 hp)
Torque (at rated speed) @ 2650 rpm	64.4 N•m (47.5 lb-ft)
Torque (maximum): @ 1600 rpm	75.7 N•m (55.8 lb-ft)
Number of Cylinders	3
Bore	78 mm (3.07 in.)
Stroke	84 mm (3.31 in.)
Displacement	1.204 L (73.5 cu in.)
Firing Order	1 - 3 - 2
Direction of Rotation	Counterclockwise (viewed from flywheel)
Combustion System	Direct Injection Type
Compression Ratio	18 to 1
Cooling	Liquid
Oil Capacity (w/filter)	Approximately 2 L (2.2 qt)
Governor	Centrifugal
Slow Idle (No Load)	950 ± 25 rpm
High Idle (No Load)	2850 ± 25 rpm

Repair Specifications

Valve Train:

Rocker Arm Shaft OD	15.97 - 15.98 mm (0.628 - 0.629 in.)
Wear Limit	15.95 mm (0.628 in.)
Rocker Arm and Shaft Support Bushing ID	16.00 - 16.02 mm (0.630 - 0.631 in.)
Wear Limit	16.09 mm (0.633 in.)
Oil Clearance	0.016 - 0.054 mm (0.0006 - 0.0021 in.)
Wear Limit	0.14 mm (0.006 in.)
Push Rod Bend (maximum)	0.0 - 0.03 mm (0.0 - 0.001 in.)

Cylinder Head and Valves:

Cylinder Head Distortion	0.0 - 0.05 mm (0.0 - 0.002 in.)
Wear Limit	0.15 mm (0.006 in.)
Valve Seat Width:	
Intake	1.36 - 1.53 mm (0.054 - 0.060 in.)
Wear Limit	1.98 mm (0.078 in.)
Exhaust	1.66 - 1.87 mm (0.066 - 0.074 in.)
Wear Limit	2.27 mm (0.089 in.)

ENGINE - 24 HP DIESEL SPECIFICATIONS

Valve Seat Angles:

Intake Valve	30°
Exhaust Valve	45°
Lower Seat Surface	70°
Upper Seat Surface	15°

Valve Stem Diameter:

Intake	6.95 - 6.96 mm (0.274 - 0.274 in.)
Exhaust	6.94 - 6.96 mm (0.273 - 0.274 in.)
Wear Limit (Intake and Exhaust)	6.90 mm (0.272 in.)

Valve Head Margin:

Intake	1.24 - 1.44 mm (0.049 - 0.057 in.)
Exhaust	1.35 - 1.55 mm (0.053 - 0.061 in.)
Wear Limit (Intake and Exhaust)	0.50 mm (0.020 in.)

Valve Recession:

Intake	0.30 - 0.50 mm (0.012 - 0.020 in.)
Exhaust	0.30 - 0.50 mm (0.012 - 0.020 in.)
Wear Limit (Intake and Exhaust)	1.00 mm (0.039 in.)

Valve Stem-To-Valve Guide Oil Clearance:

Intake	0.04 - 0.07 mm (0.001 - 0.003 in.)
Exhaust	0.05 - 0.08 mm (0.002 - 0.003 in.)
Wear Limit	0.18 mm (0.007 in.)

Valve Guide:

ID	7.00 - 7.02 mm (0.275 - 0.276 in.)
Wear Limit	7.08 mm (0.279 in.)
Installed Height	12 mm (0.472 in.)

Valve Spring:

Free Length	44.4 mm (1.748 in.)
Maximum Inclination (All)	1.10 mm (0.044 in.)
Tension (Measured With Spring Compressed 1.0 mm (0.039 in.))	3.61 - 2.71 kg (7.96 - 5.98 lb)

Valve Timing:

Intake Valve Opens	10° - 20° BTDC
Intake Valve Closes	40° - 50° ABDC
Exhaust Valve Opens	51° - 61° BBDC
Exhaust Valve Closes	13° - 23° ATDC
Piston-to-Cylinder Head Clearance	0.66 - 0.78 mm (0.026 - 0.031 in.)

Connecting Rod:

Large End Bearing ID	46.00 - 46.02 mm (1.811 - 1.812 in.)
Large End Bearing Thickness	1.49 - 1.50 mm (0.059 - 0.059 in.)
Oversize	1.625 mm (0.064 in.)
Large End Bearing Oil Clearance	0.04 - 0.09 mm (0.002 - 0.004 in.)
Wear Limit	0.16 mm (0.006 in.)
Connecting Rod Side Play	0.2 - 0.4 mm (0.008 - 0.016 in.)
Twist and Parallelism	0.00 - 0.03 mm per 100 mm (0.00 - 0.001 in. per 6 in.)

ENGINE - 24 HP DIESEL SPECIFICATIONS

Wear Limit 0.08 mm per 100 mm (0.005 in. per 6 in.)

Piston Rings:

First Compression Piston Ring Groove Width 2.065 - 2.08 mm (0.081 - 0.082 in.)

First Compression Piston Ring Width 1.97 - 1.99 mm (0.078 - 0.078 in.)

First Compression Ring Minimum Side Clearance 0.075 - 0.110 mm (0.003 - 0.004 in.)

Second Compression Piston Ring Groove Width 2.035 - 2.05 mm (0.080 - 0.081 in.)

Second Compression Piston Ring Width (All) 1.97 - 1.99 mm (0.078 - 0.078 in.)

Second Compression Piston Ring Minimum Side Clearance 0.045 - 0.08 mm (0.002 - 0.003 in.)

Oil Control Piston Ring Groove Width 4.015 - 4.03 mm (0.158 - 0.159 in.)

Oil Control Piston Ring Width 3.97 - 3.99 mm (0.156 - 0.157 in.)

Oil Control Piston Ring Minimum Side Clearance 0.025 - 0.06 mm (0.001 - 0.002 in.)

Piston Ring End Gap 0.20 - 0.40 mm (0.008 - 0.016 in.)

Wear Limit 1.50 mm (0.059 in.)

Piston Pin:

Piston Pin OD 22.99 - 23.00 mm (0.905 - 0.906 in.)

Wear Limit 22.90 mm (0.902 in.)

Piston Pin Bushing ID 23.025 - 23.038 mm (0.906 - 0.907 in.)

Wear Limit 23.10 mm (0.909 in.)

Piston Pin-To-Rod Bore Oil Clearance 0.025 - 0.047 mm (0.001 - 0.002 in.)

Wear Limit 0.2 mm (0.008 in.)

Piston Pin Bore (In Piston) ID 23.00 - 23.008 mm (0.9055 - 0.906 in.)

Wear Limit 23.02 mm (0.906 in.)

Piston Pin-To-Piston Oil Clearance 0.00 - 0.017 mm (0.0 - 0.0007 in.)

Wear Limit 0.12 mm (0.005 in.)

Piston (Measured 24 mm (0.945 in.) up from bottom of piston skirt, perpendicular to piston pin):

Standard Piston OD 77.95 - 77.98 mm (3.069 - 3.070 in.)

Wear Limit 77.90 mm (3.067 in.)

Oversize Piston OD 78.20 - 78.23 mm (3.079 - 3.080 in.)

Wear Limit 78.15 mm (3.077 in.)

Cylinder Bore:

Standard Bore ID 78.00 - 78.03 mm (3.071 - 3.072 in.)

Wear Limit 78.20 mm (3.067 in.)

Oversize Bore ID 78.25 - 78.28 mm (3.081 - 3.082 in.)

Piston-to-Cylinder Clearance 0.050 (0.014 - 0.002 in.)

Cylinder Roundness 0.01 - 0.03 mm (0 - 0.001 in.)

Wear Limit 0.03 mm (0.001 in.)

Cylinder Taper 0.00 - 0.01 mm (0 - 0.0004 in.)

Wear Limit 0.03 mm (0.001 in.)

Deglazing 30 - 40° crosshatch pattern

Reboring 30 - 40° crosshatch pattern

ENGINE - 24 HP DIESEL SPECIFICATIONS

Crankshaft and Main Bearings:

Connecting Rod Crankshaft Journal OD	42.95 - 42.96 mm (1.691 - 1.691 in.)
Wear Limit	42.91 mm (1.689 in.)
Main Bearing Journal OD	46.95 - 46.91 mm (1.848 - 1.849 in.)
Wear Limit	42.91 mm (1.689 in.)
Main Bearing Oil Clearance	0.04 - 0.09 mm (0.002 - 0.004 in.)
Wear Limit	0.25 mm (0.010 in.)
Crankshaft Bend (Maximum)	0.02 mm (0.001 in.)
Crankshaft End Play	0.09 - 0.27 mm (0.004 - 0.011 in.)

Camshaft:

Camshaft End Play	0.05 - 0.25 mm (0.002 - 0.010 in.)
Camshaft Bend	0 - 0.02 mm (0 - 0.001 in.)
Wear Limit	0.05 mm (0.002 in.)
Camshaft Side Gap	0.05 - 0.25 mm (0.002 - 0.010 in.)
Lobe Height (Intake and Exhaust)	38.64 - 38.77 mm (1.521 - 1.526 in.)
Wear Limit	38.40 mm (1.512 in.)

Bearing Journal OD:

Flywheel Side and Gear Side	44.93 - 44.95 mm (1.769 - 1.770 in.)
Intermediate Journal	44.91 - 44.94 mm (1.768 - 1.769 in.)
Wear Limit	44.85 mm (1.766 in.)
Oil Clearance (Gear and Flywheel Ends)	0.04 - 0.13 mm (0.002 - 0.005 in.)
Oil Clearance (Intermediate)	0.07 - 0.12 mm (0.003 - 0.005 in.)

Camshaft Followers:

Stem OD	11.98 - 11.99 mm (0.471 - 0.472 in.)
Wear Limit	11.93 mm (0.470 in.)
Bore ID	12.00 - 12.02 mm (0.472 - 0.473 in.)
Wear Limit	12.05 mm (0.474 in.)
Oil Clearance	0.01 - 0.04 mm (0.0004 - 0.0016 in.)
Wear Limit	0.12 mm (0.005 in.)

Idler Gear:

Shaft OD	45.95 - 45.98 mm (1.809 - 1.810 in.)
Wear Limit	45.93 mm (1.808 in.)
Bushing ID	46.00 - 46.03 mm (1.811 - 1.812 in.)
Wear Limit	46.08 mm (1.814 in.)
Clearance	0.25 mm (0.001 in.)

Oil Pump:

Rotor Shaft OD to Side Cover Hole ID Clearance	0.01 - 0.04 mm (0.001 - 0.002 in.)
Wear Limit	0.20 mm (0.08 in.)
Inner Rotor and Outer Rotor-to-Pump Body Side Clearance:	0.05 - 0.10 mm (0.002 - 0.004 in.)
Wear Limit	0.15 mm (0.006 in.)

ENGINE - 24 HP DIESEL SPECIFICATIONS

Outer Rotor to Pump Body Clearance	0.10 - 0.16 mm (0.004 - 0.006 in.)
Wear Limit	0.25 mm (0.010 in.)
Inner Rotor to Outer Rotor Clearance Wear Limit	0.15 mm (0.006 in.)

Tests and Adjustment Specifications

Valve Clearance	0.15 - 0.25 mm (0.006 - 0.010 in.)
Connecting Rod Side Play	0.2 - 0.4 mm (0.008 - 0.016 in.)
Connecting Rod Bearing Clearance	0.04 - 0.09 mm (0.002 - 0.004 in.)
Crankshaft End Play	0.09 - 0.27 mm (0.004 - 0.011 in.)
Crankshaft Main Bearing Clearance	0.04 - 0.09 mm (0.002 - 0.004 in.)
Camshaft End Play	0.05 - 0.25 mm (0.002 - 0.010 in.)
Timing Gear Backlash:	
All Except Oil Pump Gear	0.07 - 0.15 mm (0.003 - 0.005 in.)
Oil Pump Gear	0.11 - 0.19 mm (0.004 - 0.008 in.)
Fuel Injection Nozzle:	
Opening Pressure	19600 + 1000/ - 0 kPa (2844 + 145/ - 0 psi)
Leakage at 11032 kPa (1600 psi)	None for a minimum of 10 seconds
Chatter and Spray Pattern at 19600 ± 1000 kPa (2843 ± 145 psi):	
Slow Hand Lever Movement	Chatter Sound
Slow Hand Lever Movement	Fine Stream
Fast Hand Lever Movement	Fine Atomized Spray; 150° Spray Pattern
Alternator Drive Belt Deflection	10 - 15 mm (0.4 - 0.6 in.)

Operational Tests

Cooling System Test Pressure	88 ± 15 kPa (12.8 ± 2.2 psi)
Thermostat Opening Temperature	69.5 - 72.5° C (157 - 163° F)
Minimum Lift Height above 85° C (185° F)	8.0 mm (0.135 in.)
Radiator Cap Opening Pressure	88 ± 15 kPa (12.8 ± 2.2 psi)
Cylinder Compression Pressure @250 RPM Cranking Speed:	3138 kPa (455 psi)
(Minimum)	2450 kPa (360 psi)
Difference Between Cylinders (Maximum)	245 kPa (36 psi)
Oil Pressure:	
Rated Speed	0.29 ± 0.005 MPa (42 ± 7.2 psi)
Slow Idle (Minimum)	0.06 MPa (8.7 psi)
Oil Relief Valve Opening Pressure	294 - 392 kPa (43 - 57 psi)
Oil Pressure Switch Opening Pressure	41 - 62 kPa (6 - 9 psi)

ENGINE - 24 HP DIESEL SPECIFICATIONS

Torque Values, Non-Standard Fasteners

Cylinder Head Bolts (Lubricating Oil Applied)	67 - 71 N•m (49 - 52 lb-ft)
Connecting Rod Bolts (Lubricating Oil Applied).	37 - 41 N•m (27 - 30 lb-ft)
Flywheel Mounting Bolts (Lubricating Oil Applied)	83 - 88 N•m (62 - 65 lb-ft)
Main Bearing Bolts (Lubricating Oil Applied):.	76.5 - 80.4 N•m (56 - 59 lb-ft)
Crankshaft Pulley Cap Screw (Lubricating Oil Applied).	113 - 122 N•m (83 - 90 lb-ft)
Fuel Injector Nozzle Nut	6.9 - 8.8 N•m (5 - 6.5 lb-ft)
Governor Weight Support Nut.	44 - 49 N•m (33 - 36 lb-ft)
Rocker Arm Mounting Cap Screw and Nut	26 N•m (19 lb-ft)
Oil Pump Mounting Cap Screw	25 N•m (18 lb-ft)
Starting Motor Mounting Bolts	47 N•m (35 lb-ft)

Special Tools

NOTE: Order tools according to information given in the U.S. SERVICE-GARD™ Catalog or in the European Microfiche Tool Catalog (MTC).

Number	Name	Use
JDG991	Fast Idle Adjustment Tool	Use to set fast idle.
D15001NU	Magnetic Follower Holder Kit	Hold cam followers when removing and installing camshaft
JDF13	Nozzle Cleaning Kit	Use to clean fuel injection nozzles.
D-20019WI	Valve Guide Knurler	Use to knurl inside diameter of valve guides.
JDE118	Valve Guide Driver	Use to remove and install valve guides in cylinder head.
D-20021WI	Valve Guide Reamer	Use to ream out valve guides.

Other Materials

Number	Name	Use
TY15130 LOCTITE®	John Deere Form-In-Place Gasket	Seals rear oil seal case and flywheel housing to engine block. Seals oil pan to timing gear housing and engine block.
TY9370 LOCTITE® No. 242	Thread Lock and Sealer (Medium Strength)	Apply to threads of crankshaft pulley cap screw.

LOCTITE® is a registered trademark of the Loctite Corp.

ENGINE - 24 HP DIESEL THEORY OF OPERATION

Theory of Operation

Fuel and Air System Operation

Function:

Fuel system supplies fuel to injection nozzles.

The air intake system filters and supplies air needed for combustion.

Theory of Operation:

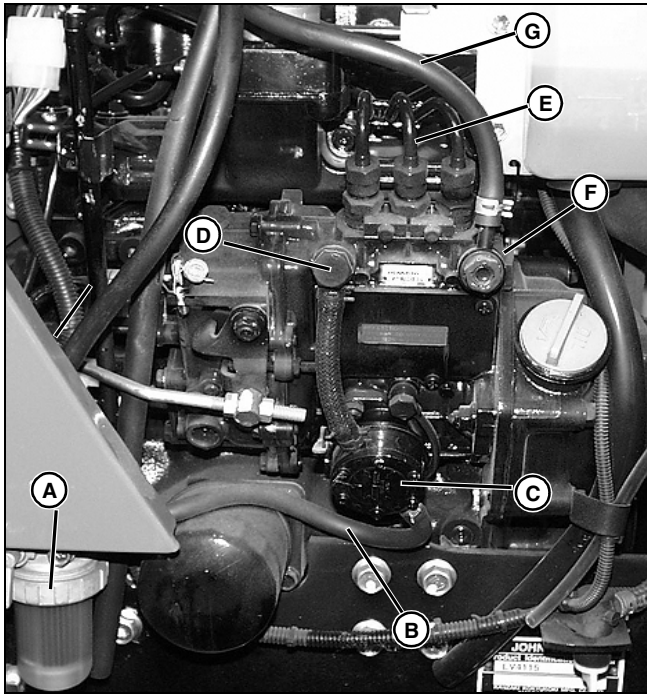

MX14414

Fuel System:

Fuel is gravity fed from the fuel tank outlet to fuel filter/water separator (A). The fuel is drawn from the fuel filter/water separator through fuel line (B) to the fuel transfer pump (C). The fuel is pressurized and fed to the injection pump inlet (D). The injection pump then directs high pressure fuel through the injector lines (E) to the injectors and then into the cylinder for combustion. Excess fuel from the injector pump along with excess fuel from the injectors, is teed together in fitting (F) and returned to the fuel tank through line (G).

If the machine runs out of fuel, there is an air bleed line that allows air to escape from the top of the filter. The air in the injection pump and injectors will be forced out of the return lines. These two lines allow the system to be self bleeding.

The engine speed is controlled by the throttle lever and rod. The rod is connected to the injection pump governor control lever. The fuel shutoff solenoid controls the injection pump shutoff shaft. When the solenoid is retracted (key in the START or ON position), the engine can be started. When the key is turned OFF, return springs on the shutoff shaft extend the solenoid, moving the shutoff linkage to the OFF position. The solenoid also closes if the machine is operated in an unsafe condition. (See "Engine Shutoff Circuit Operation" in the Electrical section.)

The injection pump meters fuel as determined by the governor and delivers it at high pressure to the injector nozzles.

The injector nozzle prevents flow until high pressure is reached, opening the valve and spraying atomized fuel into the combustion chamber. Injector lines contain trapped fuel whenever injection is not taking place.

A small amount of fuel leaks past the nozzle valve to lubricate the fuel injection nozzle. This leakage combines with excess fuel from the injection pump and is returned to tank. Any air in the fuel system is bled out with return fuel to the fuel tank.

A fuel level sensor mounted in the fuel tank informs the operator of the fuel level.

Air Intake System:

Engine intake air enters the inlet hose (A) behind the grille, and flows into the air filter body (B). The air cleaner also has a rubber, one way, unloading valve (C), that removes heavy dirt particles from the air stream during engine operation before they reach the filters. The operator can squeeze the valve to remove the large particles. The air cleaner elements filter the air, which then flows through hose (D) to the intake manifold.

An air filter restriction indicator (E) at the rear of the air cleaner informs the operator when the air filter needs servicing.

ENGINE - 24 HP DIESEL THEORY OF OPERATION

Cooling System Operation

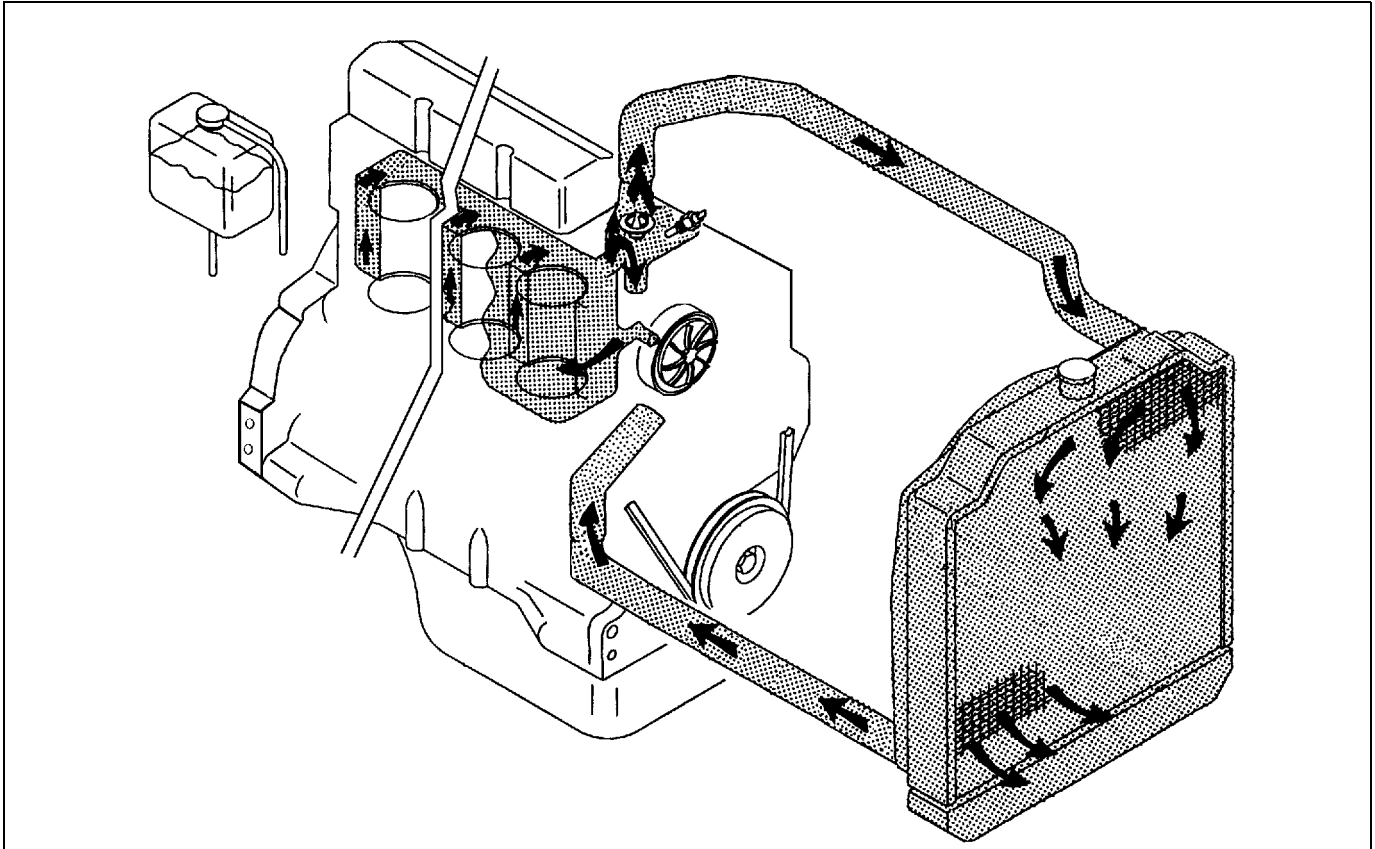

MX1026

Function:

The coolant pump circulates coolant through the cooling system, drawing hot coolant from the engine block, circulating it through the radiator for cooling.

Theory of Operation:

The pressurized cooling system includes the radiator, water pump, fan and thermostat.

During the warm-up period, the thermostat remains closed and the impeller type coolant pump draws coolant from the bypass tube. Coolant from the pump flows to the cylinder block water jacket and up through the cylinder head providing a fast warm-up.

Once the engine has reached operating temperature, the thermostat opens and coolant is pumped from the bottom of the radiator via the lower radiator hose into the cylinder block. Here it circulates through the block and around the cylinders.

From the block, coolant is then directed through the cylinder head, and into thermostat housing. With the thermostat open;

Start To Open **69.5 - 72.5° C (157 - 163° F)**

Fully Opened **85° C (185° F)**

warm engine coolant passes through the housing into the top of the radiator where it is circulated to dissipate heat.

When coolant system pressure exceeds **88.3 kPa (12.8 psi)**, a valve in the radiator cap opens, discharging coolant into the coolant recovery tank.

As the coolant temperature is reduced, a vacuum is produced in the radiator and coolant is drawn back out of the coolant recovery tank through a valve in the radiator cap.

A coolant temperature sensor inputs to a gauge, which informs the operator of the engine coolant temperature, and warns of a high temperature condition by activating a warning lamp.

ENGINE - 24 HP DIESEL THEORY OF OPERATION

Lubrication System Operation

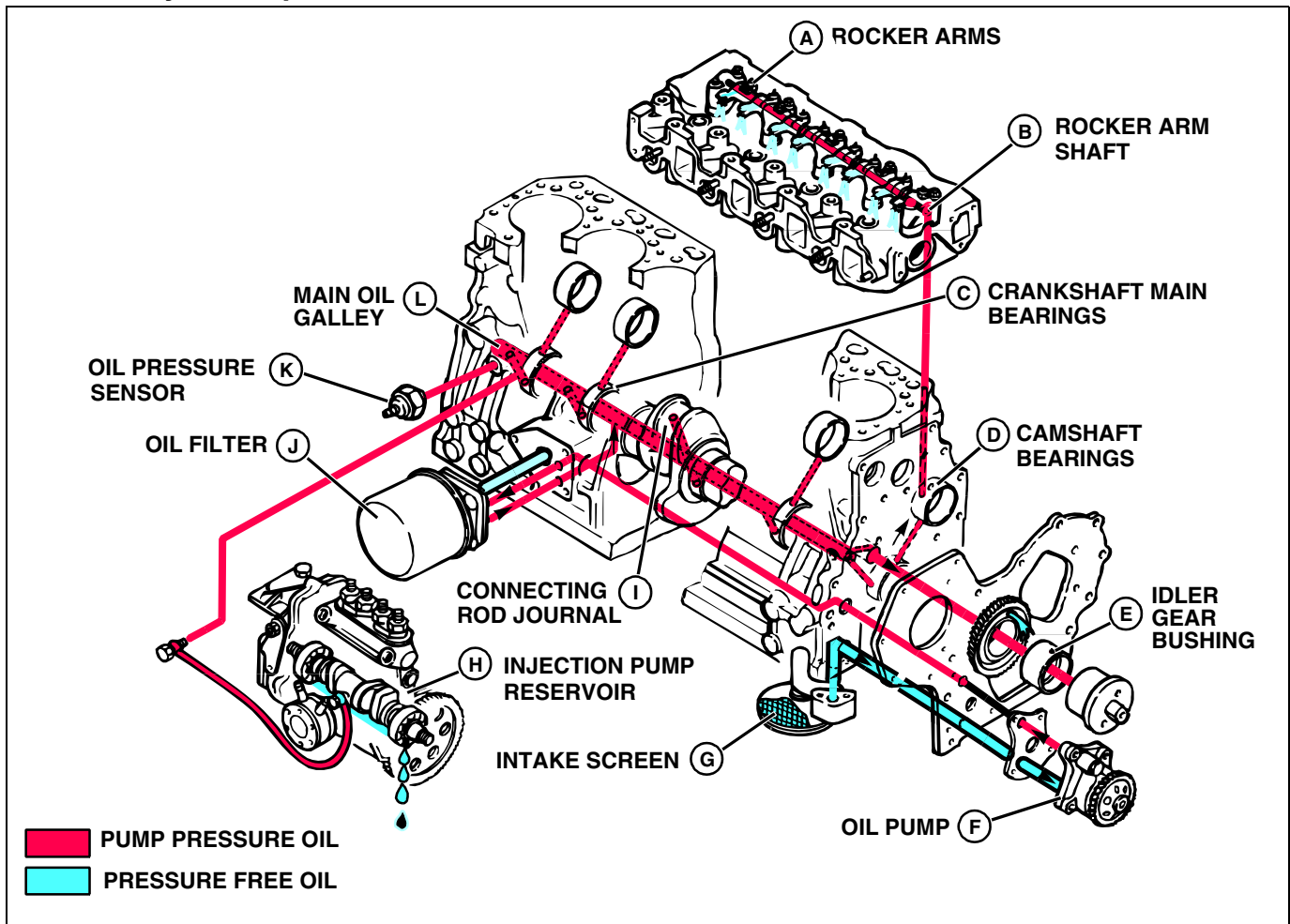

MIF

Function:

A full pressure system lubricates engine parts with filtered oil.

Theory of Operation:

The pressure lubrication system consists of a positive displacement gear-driven pump (F), oil strainer (G), full flow oil filter (J), oil pressure regulating valve and an electrical oil pressure warning switch. (K)

The pump draws lubrication oil from the oil pan through a strainer and a suction tube. The oil is then pumped through an oil passage to the oil filter and through the engine block main oil galley (L).

From the main oil galley, oil is forwarded under pressure to the crankshaft main bearing journals (C) and idler gear bushing (E). Drilled cross-passages in the crankshaft (I) distribute the oil from the main bearings to connecting rod bearings.

Lube oil holes in main bearing oil grooves direct oil to the camshaft bearings (D).

A drilled passage from the rear camshaft bearing through the cylinder block and cylinder head supplies lubricating oil to the rocker arm shaft (B). The hollow rocker arm shaft distributes oil to the rocker arms (A), cam followers and valves.

Lubrication oil is supplied to the fuel injection pump (H) from the main oil galley through external oil lines.

An oil pressure sensor (K) activates an indicator light to alert the operator to shut down the engine if oil pressure drops below specification.

ENGINE - 24 HP DIESEL DIAGNOSTICS

Diagnostics

Engine Troubleshooting



CAUTION: Avoid Injury! The engine may start to rotate at any time. Keep hands away from all moving parts when testing.

Coolant in the radiator is extremely hot during operation.

Engine

Symptom: Engine Will Not Start

(1) Proper starting procedure being used is correct for conditions.

Yes - Go to step (2).

No - Use correct procedure for conditions See the Operator's Manual. Go to step (2) if problem continues.

(2) Battery 12.7 VDC or higher?

Yes - Go to step (3).

No - Charge and check battery. See "Battery Voltage and Specific Gravity Test" on page 303. Go to step (3) if problem continues.

(3) No open circuits in wiring?

Yes - Go to step (4).

No - Repair or replace as needed. See "Common Circuit Tests" on page 206. Go to step (4) if problem continues.

(4) Starting motor functioning properly?

Yes - Go to step (5).

No - Repair or replace starting motor. Go to step (5) if problem continues.

(5) Alternator output correct?

Yes - Go to step (6).

No - Repair or replace alternator. Go to step (6) if problem continues.

(6) Engine oil of correct viscosity and type?

Yes - Go to step (7).

No - Replace engine oil with oil of proper viscosity and type. Replace oil filter.

(7) No water in fuel?

Yes - Go to step (8).

Symptom: Engine Will Not Start

No - Drain and replace fuel. Go to step (8) if problem continues.

(8) Fuel filter not clogged?

Yes - Go to step (9).

No - Replace fuel filter. See "Fuel Filter/Water Separator" on page 107. Go to step (9) if problem continues.

(9) No air leak in fuel system?

Yes - Go to step (10).

No - Repair fuel system. Go to step (10) if problem continues.

(10) Fuel lines not plugged, pinched or cracked?

Yes - Go to step (11).

No - Repair or replace fuel lines as needed. Go to step (11) if problem continues.

(11) Correct volume of fuel supplied to injection pump?

Yes - Go to step (12).

No - Replace fuel transfer pump. See "Fuel Transfer Pump Tests" on page 149. Go to step (12) if problem continues.

(12) Intake and/or exhaust valve clearance correct?

Yes - Go to step (13).

No - Adjust valve clearance. Go to step (13) if problem continues.

(13) Timing between injection pump, intake and exhaust valves proper?

Yes - Go to step (14).

No - Adjust valve clearance. Check valve timing. Go to step (14) if problem continues.

(14) Intake and/or exhaust valve not seized?

Yes - Go to step (15).

No - Replace valve and check valve guide. Go to step (15) if problem continues.

(15) Piston rings not broken or seized?

Yes - Go to step (16).

No - Replace rings. Check piston and cylinder. Go to step (16) if problem continues.

(16) Piston rings, piston or cylinder not worn?

Yes - Go to step (17).

ENGINE - 24 HP DIESEL DIAGNOSTICS

Symptom: Engine Will Not Start

No - Replace piston and/or rings, bore or hone cylinder. Go to step (17) if problem continues.

(17) Crankshaft pin or bearing not seized?

Yes - Go to step (1).

No - Regrind crankshaft and replace bearings. Go to step (1) if problem continues.

Symptom: Engine Starts But Does Not Continue Running - No Exhaust Smoke

(1) Engine oil of proper viscosity and type.

Yes - Go to step (2).

No - Replace engine oil filter and oil of proper viscosity and type. Go to step (2) if problem continues.

(2) Fuel filter not clogged?

Yes - Go to step (3).

No - Replace fuel filter. See "Fuel Filter/Water Separator" on page 107. Go to step (3) if problem continues.

(3) No air leak in fuel system?

Yes - Go to step (4).

No - Repair fuel system. Go to step (4) if problem continues.

(4) Fuel lines not plugged, pinched or cracked?

Yes - Go to step (5).

No - Repair or replace fuel lines as needed. Go to step (5) if problem continues.

(5) Correct volume of fuel supplied to injection pump?

Yes - Go to step (6).

No - Replace fuel transfer pump. See "Fuel Filter/Water Separator" on page 107. Go to step (6) if problem continues.

(6) Valve clearance proper?

Yes - Go to step (7).

No - Adjust valve clearance. Go to step (7) if problem continues.

(7) Crankshaft pin or bearing not seized?

Yes - Go to step (1).

No - Regrind crankshaft and replace bearings. Go to step (1) if problem continues.

Symptom: Engine Starts But Does Not Continue Running - Excess Exhaust Smoke

(1) No water in fuel?

Yes - Go to step (2).

No - Drain and replace fuel. Go to step (2) if problem continues.

(2) Fuel filter not clogged?

Yes - Go to step (3).

No - Replace fuel filter. See "Fuel Filter/Water Separator" on page 107. Go to step (3) if problem continues.

(3) Intake and/or exhaust valve not seized?

Yes - Go to step (4).

No - Replace valve and check valve guide. Go to step (4) if problem continues.

(4) Piston rings not broken or seized?

Yes - Go to step (5).

No - Replace rings. Check piston and cylinder. Go to step (5) if problem continues.

(5) Piston rings, piston or cylinder not worn?

Yes - Go to step (1).

No - Replace piston and/or rings, bore or hone cylinder. Go to step (1) if problem continues.

Symptom: Low Engine Output - Exhaust color NORMAL

(1) Correct type of fuel being used?

Yes - Go to step (2).

No - Drain and replace fuel. Go to step (2) if problem continues.

(2) Proper type and viscosity of oil being used?

Yes - Go to step (3).

No - Replace engine oil and filter. Go to step (3) if problem continues.

(3) Fuel filter not clogged?

Yes - Go to step (4).

No - Replace fuel filter. Go to step (4) if problem continues.

(4) Fuel lines not clogged, cracked or pinched?

Yes - Go to step (5).

ENGINE - 24 HP DIESEL DIAGNOSTICS

Symptom: Low Engine Output - Exhaust color NORMAL

No - Clean or replace fuel lines. Go to step (5) if problem continues.

(5) No air leakage into fuel system?

Yes - Go to step (6).

No - Repair fuel supply system. Go to step (6) if problem continues.

(6) Proper volume of fuel to injection pump?

Yes - Go to step (7).

No - Check or replace fuel transfer pump. Go to step (7) if problem continues.

(7) Intake and exhaust valve clearance correct?

Yes - Go to step (8).

No - Adjust valve clearance. Go to step (8) if problem continues.

(8) Intake or exhaust valves not leaking compression?

Yes - Go to step (9).

No - Grind valves and seats. Go to step (9) if problem continues.

(9) Intake or exhaust valves not seized?

Yes - Go to step (10).

No - Replace valve and check valve guide. Go to step (10) if problem continues.

(10) Cylinder head gasket not leaking compression?

Yes - Go to step (11).

No - Replace head gasket, Resurface head and block if necessary. Go to step (11) if problem continues.

(11) Crankshaft pin or bearing not worn?

Yes - Go to step (1).

No - Grind crankshaft and replace bearings. Go to step (1) if problem continues.

Symptom: Low Engine Output - Exhaust color WHITE**(1) Correct type of fuel?**

Yes - Go to step (2).

No - Drain and replace fuel. Go to step (2) if problem continues.

(2) No water in fuel?

Symptom: Low Engine Output - Exhaust color WHITE

Yes - Go to step (3).

No - Drain and replace fuel. Go to step (3) if problem continues.

(3) Even volume of fuel being injected?

Yes - Go to step (4).

No - Repair or replace fuel injector pump or fuel injectors. Go to step (4) if problem continues.

(4) Proper spray pattern from injectors?

Yes - Go to step (5).

No - Clean or replace fuel injector nozzles. Go to step (5) if problem continues.

(5) Intake or exhaust valve stems not worn?

Yes - Go to step (6).

No - Replace valve guides and valves. Go to step (6) if problem continues.

(6) Timing proper between injection pump, intake and exhaust valves?

Yes - Go to step (7).

No - Adjust valve clearance. Go to step (7) if problem continues.

(7) Piston rings installed correctly?

Yes - Go to step (8).

No - Install piston rings correctly. Go to step (8) if problem continues.

(8) Piston ring ends staggered?

Yes - Go to step (9).

No - Stagger piston ring ends. Go to step (9) if problem continues.

(9) Piston, rings, or cylinder not worn?

Yes - Go to step (10).

No - Replace pistons and rings, bore or hone cylinders. Go to step (10) if problem continues.

(10) Piston rings not broken or seized?

Yes - Go to step (1).

No - Replace rings. Replace pistons if damaged. Bore cylinder if damaged. Go to step (1) if problem continues.

ENGINE - 24 HP DIESEL DIAGNOSTICS

Symptom: Low Engine Output - Exhaust color BLACK

(1) Correct type of fuel?

Yes - Go to step (2).

No - Drain and replace fuel. Go to step (2) if problem continues.

(2) Air filter elements not clogged?

Yes - Go to step (3).

No - Clean or replace air filter elements. Go to step (3) if problem continues.

(3) Exhaust pipe not clogged?

Yes - Go to step (4).

No - Clean exhaust pipe. Go to step (4) if problem continues.

(4) Engine running cool enough?

Yes - Go to step (5).

No - Check thermostat, replace if faulty. Adjust fan belt tension. Go to step (5) if problem continues.

(5) Cooling system filled to correct level?

Yes - Go to step (6).

No - Check for leaks and fill system to correct level. Go to step (6) if problem continues.

(6) Correct volume of fuel being injected?

Yes - Go to step (7).

No - Replace faulty fuel injector pump or fuel injectors. Go to step (7) if problem continues.

(7) Correct pattern from fuel injectors?

Yes - Go to step (8).

No - Clean or replace fuel injector nozzles. Go to step (8) if problem continues.

(8) Proper timing between injection pump, intake and exhaust valves?

Yes - Go to step (9).

No - Adjust valve clearance. Go to step (9) if problem continues.

(9) Intake or exhaust valves not leaking compression?

Yes - Go to step (10).

No - Grind valves and seats. Go to step (10) if problem continues.

(10) Intake or exhaust valve not seized?

Symptom: Low Engine Output - Exhaust color BLACK

Yes - Go to step (11).

No - Replace valve and check valve guide. Go to step (11) if problem continues.

(11) Engine being run under high altitude or high temperature conditions.

Symptom: Exhaust color WHITE under load

(1) Correct type of fuel?

Yes - Go to step (2).

No - Drain and replace fuel. Go to step (2) if problem continues.

(2) No water in fuel?

Yes - Go to step (3).

No - Drain and replace fuel. Go to step (3) if problem continues.

(3) Engine not running too cool?

Yes - Go to step (4).

No - Check thermostat, replace if faulty. Go to step (4) if problem continues.

(4) Correct volume of fuel being injected?

Yes - Go to step (5).

No - Replace faulty fuel injector pump or fuel injectors. Go to step (5) if problem continues.

(5) Correct pattern from fuel injectors?

Yes - Go to step (6).

No - Clean or replace fuel injector nozzles. Go to step (6) if problem continues.

(6) Proper timing between injection pump, intake and exhaust valves?

Yes - Go to step (7).

No - Adjust valve clearance. Go to step (7) if problem continues.

(7) Piston rings installed correctly?

Yes - Go to step (8).

No - Install piston rings correctly. Go to step (8) if problem continues.

(8) Piston, rings or cylinder not worn?

Yes - Go to step (9).

ENGINE - 24 HP DIESEL DIAGNOSTICS

Symptom: Exhaust color **WHITE** under load

No - Replace pistons and rings, bore or hone cylinders. Go to step (9) if problem continues.

(9) Piston rings not broken or seized?

Yes - Go to step (1).

No - Replace rings. Check pistons and cylinders. Go to step (1) if problem continues.

Symptom: Exhaust color **BLACK** under load

(1) Correct type of fuel?

Yes - Go to step (2).

No - Drain and replace fuel. Go to step (2) if problem continues.

(2) Air filter elements not clogged?

Yes - Go to step (3).

No - Clean or replace air filter elements. Go to step (3) if problem continues.

(3) Exhaust pipe not clogged?

Yes - Go to step (4).

No - Clean exhaust pipe. Go to step (4) if problem continues.

(4) Even volume of fuel being injected?

Yes - Go to step (5).

No - Repair or replace fuel injector pump or fuel injectors. Go to step (5) if problem continues.

(5) Correct volume of fuel being injected?

Yes - Go to step (6).

No - Replace faulty fuel injector pump or fuel injectors. Go to step (6) if problem continues.

(6) Proper spray pattern from injectors?

Yes - Go to step (7).

No - Clean or replace fuel injector nozzles. Go to step (7) if problem continues.

(7) Timing proper between injection pump, intake and exhaust valves?

Yes - Go to step (8).

No - Adjust valve clearance. Go to step (8) if problem continues.

(8) Intake or exhaust valves not leaking compression?

Yes - Go to step (9).

Symptom: Exhaust color **BLACK** under load

No - Grind valves and seats. Go to step (9) if problem continues.

(9) Intake or exhaust valves not seized?

Yes - Go to step (10).

No - Replace valve and check valve guide. Go to step (10) if problem continues.

(10) Engine being run under high altitude or high temperature conditions?

Symptom: Exhaust temperature too high

(1) Cooling system filled to correct level?

Yes - Go to step (2).

No - Check for leaks and fill system to correct level. Go to step (2) if problem continues.

(2) Engine running cool enough?

Yes - Go to step (3).

No - Check thermostat, replace if faulty. Adjust fan belt tension. Go to step (3) if problem continues.

(3) Exhaust pipe not clogged?

Yes - Go to step (4).

No - Clean exhaust pipe. Go to step (4) if problem continues.

(4) Even volume of fuel being injected?

Yes - Go to step (5).

No - Repair or replace fuel injector pump or fuel injectors. Go to step (5) if problem continues.

(5) Correct volume of fuel being injected?

Yes - Go to step (6).

No - Replace faulty fuel injector pump or fuel injectors. Go to step (6) if problem continues.

(6) Intake or exhaust valve clearance correct?

Yes - Go to step (7).

No - Adjust valve clearance. Go to step (7) if problem continues.

(7) Intake or exhaust valves not leaking compression?

Yes - Go to step (8).

No - Grind valves and seats. Go to step (8) if problem continues.

(8) Piston rings not broken or seized?

ENGINE - 24 HP DIESEL DIAGNOSTICS

Symptom: Exhaust temperature too high

Yes - Go to step (1).

No - Replace rings. Replace pistons if damaged. Bole cylinder if damaged. Go to step (1) if problem continues.

Symptom: Engine Runs Rough - Misfiring

(1) Intake or exhaust valve clearance correct?

Yes - Go to step (2).

No - Adjust valve clearance. Go to step (2) if problem continues.

(2) Timing between injection pump, intake and exhaust valves proper?

Yes - Go to step (3).

No - Adjust valve clearance. Check valve timing. Go to step (3) if problem continues.

(3) Backlash of timing gear not excessive?

Yes - Go to step (4).

No - Repair gears as needed. Go to step (4) if problem continues.

(4) Combustion chambers clean of foreign matter?

Yes - Go to step (5).

No - Clean combustion chambers. Go to step (5) if problem continues.

(5) Intake or exhaust valves not leaking compression?

Yes - Go to step (6).

No - Grind valves and seats. Go to step (6) if problem continues.

(6) Intake or exhaust valves not seized?

Yes - Go to step (7).

No - Replace valves and check valve guide. Go to step (7) if problem continues.

(7) Piston rings not broken or seized?

Yes - Go to step (8).

No - Replace rings, Check pistons and cylinders. Go to step (8) if problem continues.

(8) Crankshaft pin or bearing not worn or seized?

Yes - Go to step (9).

No - Grind crankshaft and replace bearings. Go to step (9) if problem continues.

(9) Connecting rod bolts torqued properly?

Symptom: Engine Runs Rough - Misfiring

Yes - Go to step (1).

No - Replace damaged components. Torque to correct specification. Go to step (1) if problem continues.

Symptom: Engine Runs Rough - Uneven combustion sound

(1) Correct type of fuel being used?

Yes - Go to step (2).

No - Drain and replace fuel. Go to step (2) if problem continues.

(2) No water in fuel?

Yes - Go to step (3).

No - Drain and replace fuel. Go to step (3) if problem continues.

(3) Even volume of fuel being injected?

Yes - Go to step (4).

No - Repair or replace fuel injector pump and fuel injectors. Go to step (4) if problem continues.

(4) Proper spray pattern from injectors?

Yes - Go to step (5).

No - Clean or replace fuel injector nozzles. Go to step (5) if problem continues.

(5) Air filter elements not clogged?

Yes - Go to step (6).

No - Clean or replace air filter elements. Go to step (6) if problem continues.

(6) Exhaust pipe not clogged?

Yes - Go to step (1).

No - Clean exhaust pipe. Go to step (1) if problem continues.

Symptom: Engine Runs Rough - Engine surges DURING IDLING

(1) No water in fuel?

Yes - Go to step (2).

No - Drain and replace fuel. Go to step (2) if problem continues.

(2) Even volume of fuel injected?

Yes - Go to step (3).

ENGINE - 24 HP DIESEL DIAGNOSTICS

Symptom: Engine Runs Rough - Engine surges DURING IDLING

No - Repair or replace fuel injector pump and fuel injectors. Go to step (3) if problem continues.

(3) Proper spray pattern from injectors?

Yes - Go to step (4).

No - Clean or replace fuel injector nozzles. Go to step (4) if problem continues.

(4) Piston rings not broken or seized?

Yes - Go to step (5).

No - Replace rings, Check pistons and cylinders. Go to step (5) if problem continues.

(5) Crankshaft pin or bearing not worn or seized?

Yes - Go to step (1).

No - Grind crankshaft and replace bearings. Go to step (1) if problem continues.

Symptom: Engine Runs Rough - Engine surges UNDER LOAD

(1) No water in fuel?

Yes - Go to step (2).

No - Drain and replace fuel. Go to step (2) if problem continues.

(2) Even volume of fuel injected?

Yes - Go to step (3).

No - Repair or replace fuel injector pump and fuel injectors. Go to step (3) if problem continues.

(3) Proper spray pattern from injectors?

Yes - Go to step (4).

No - Clean or replace fuel injector nozzles. Go to step (4) if problem continues.

(4) Piston rings not broken or seized?

Yes - Go to step (5).

No - Replace rings, Check pistons and cylinders. Go to step (5) if problem continues.

(5) Crankshaft pin or bearing not worn or seized?

Yes - Go to step (1).

No - Grind crankshaft and replace bearings. Go to step (1) if problem continues.

Symptom: Engine Runs Rough - Excessive Engine Vibration

(1) Even volume of fuel injected?

Yes - Go to step (2).

No - Repair or replace fuel injector pump and fuel injectors. Go to step (2) if problem continues.

(2) Proper spray pattern from injectors?

Yes - Go to step (3).

No - Clean or replace fuel injector nozzles. Go to step (3) if problem continues.

(3) Piston rings not broken or seized?

Yes - Go to step (4).

No - Replace rings, Check pistons and cylinders. Go to step (4) if problem continues.

(4) Crankshaft pin or bearing not worn or seized?

Yes - Go to step (5).

No - Grind crankshaft and replace bearings. Go to step (5) if problem continues.

(5) Connecting rod bolts torqued properly?

Yes - Go to step (1).

No - Replace damaged components. Torque to correct specification. Go to step (1) if problem continues.

Symptom: Engine Runs Rough - Poor return to low speed

(1) Go to steps procedures for "Engine Runs Rough".

ENGINE - 24 HP DIESEL DIAGNOSTICS

Fuel Consumption

Symptom: Excessive Fuel Consumption

(1) Engine not running too cool?

Yes - Go to step (2).

No - Check thermostat, replace if faulty. Go to step (2) if problem continues.

(2) Correct volume of fuel being injected?

Yes - Go to step (3).

No - Replace faulty fuel injector pump or fuel injectors. Go to step (3) if problem continues.

(3) Correct pattern from fuel injectors?

Yes - Go to step (4).

No - Clean or replace fuel injector nozzles. Go to step (4) if problem continues.

(4) Intake or exhaust valves not leaking compression?

Yes - Go to step (1).

No - Grind valves and seats. Go to step (1) if problem continues.

Lubrication

Symptom: Excessive oil consumption

(1) Engine oil of correct viscosity and type?

Yes - Go to step (2).

No - Replace engine oil with oil of proper viscosity and type. Replace oil filter. Go to step (2) if problem continues.

(2) No external or internal oil leak?

Yes - Go to step (3).

No - Repair as needed. Go to step (3) if problem continues.

(3) Intake or exhaust valve stems not worn?

Yes - Go to step (4).

No - Replace valve guides and valves. Go to step (4) if problem continues.

(4) Piston rings installed correctly?

Yes - Go to step (5).

No - Install piston rings correctly. Go to step (5) if problem continues.

(5) Piston ring ends staggered?

Yes - Go to step (6).

Symptom: Excessive oil consumption

No - Stagger piston ring ends. Go to step (6) if problem continues.

(6) Piston, rings or cylinder not worn?

Yes - Go to step (7).

No - Replace pistons and rings, bore or hone cylinders. Go to step (7) if problem continues.

(7) Piston rings not broken or seized?

Yes - Go to step (8).

No - Replace rings. Check pistons and cylinders. Go to step (8) if problem continues.

(8) No foreign matter in combustion chamber?

Yes - Go to step (1).

No - Clean head and top of piston. Check for damage. Go to step (1) if problem continues.

Symptom: Fuel oil in crankcase

(1) Correct volume of fuel being injected?

Yes - Go to step (2).

No - Replace faulty fuel injector pump or fuel injectors. Go to step (2) if problem continues.

(2) Intake or exhaust valve not seized or broken?

Yes - Go to step (3).

No - Replace valve and check valve guide. Go to step (3) if problem continues.

(3) Piston rings not broken or seized?

Yes - Go to step (4).

No - Replace rings and check pistons and cylinders. Go to step (4) if problem continues.

(4) Piston rings, piston or cylinder not worn?

Yes - Go to step (1).

No - Replace piston and or rings. Bore or hone cylinder. Go to step (1) if problem continues.

Symptom: Water in crankcase

(1) Cylinder head gasket not leaking?

Yes - Go to step (2).

No - Replace head gasket, Resurface head and block if necessary. Go to step (2) if problem continues.

(2) Water jacket not cracked?

Yes - Go to step (1).

ENGINE - 24 HP DIESEL DIAGNOSTICS

Symptom: Water in crankcase

No - Repair or replace water jacket. Go to step (1) if problem continues.

Symptom: Low oil pressure

(1) Oil at correct level?

Yes - Go to step (2).

No - Add oil. Go to step (2) if problem continues.

(2) Engine oil of correct viscosity and type?

Yes - Go to step (3).

No - Replace engine oil with oil of proper viscosity and type. Replace oil filter. Go to step (3) if problem continues.

(3) No external or internal oil leak?

Yes - Go to step (4).

No - Repair as needed. Go to step (4) if problem continues.

(4) Oil filter not clogged.

Yes - Go to step (5).

No - Replace oil filter and oil. Go to step (5) if problem continues.

(5) Oil pressure relief valve not worn or damaged?

Yes - Go to step (6).

No - Clean, adjust or replace relief valve. Go to step (6) if problem continues.

(6) Crankshaft pin or bearing not worn?

Yes - Go to step (7).

No - Grind crankshaft and replace bearings. Go to step (7) if problem continues.

(7) Connecting rod bolts torqued properly?

Yes - Go to step (8).

No - Replace damaged components. Torque to correct specification. Go to step (8) if problem continues.

(8) Water jacket not cracked?

Yes - Go to step (1).

No - Repair or replace water jacket. Go to step (1) if problem continues.

Coolant

Symptom: Overheating

(1) Cooling system filled to correct level?

Yes - Go to step (2).

No - Check for leaks and fill system to correct level. Go to step (2) if problem continues.

(2) Engine running cool enough?

Yes - Go to step (3).

No - Check thermostat, replace if faulty. Adjust fan belt tension. Go to step (3) if problem continues.

(3) Correct volume of fuel being injected?

Yes - Go to step (4).

No - Replace faulty fuel injector pump or fuel injectors. Go to step (4) if problem continues.

(4) Cylinder head gasket not leaking?

Yes - Go to step (5).

No - Replace head gasket, Resurface head and block if necessary. Go to step (5) if problem continues.

(5) Piston rings not broken or seized?

Yes - Go to step (6).

No - Replace rings. Check pistons and cylinders. Go to step (6) if problem continues.

(6) Water jacket not cracked?

Yes - Go to step (7).

No - Repair or replace water jacket. Go to step (7) if problem continues.

(7) Engine being run under high altitude or high temperature conditions.

Symptom: Low water temperature

(1) Thermostat is operating correctly?

No - Replace thermostat.

ENGINE - 24 HP DIESEL DIAGNOSTICS

Compression

Symptom: Low compression

(1) Engine oil of correct viscosity and type?

Yes - Go to step (2).

No - Replace engine oil of correct viscosity and type. Replace oil filter. Go to step (2) if problem continues.

(2) Oil filter not clogged?

Yes - Go to step (3).

No - Replace oil filter. Go to step (3) if problem continues.

(3) Correct volume of fuel being injected?

Yes - Go to step (4).

No - Replace faulty fuel injector pump or fuel injectors. Go to step (4) if problem continues.

(4) Intake or exhaust valves not leaking compression?

Yes - Go to step (5).

No - Grind valves and seats. Go to step (5) if problem continues.

(5) Intake or exhaust valve stems not worn?

Yes - Go to step (6).

No - Replace valve guides and valves. Go to step (6) if problem continues.

(6) No foreign matter in combustion chamber?

Yes - Go to step (7).

No - Clean head and top of piston. Check for damage. Go to step (7) if problem continues.

(7) Intake or exhaust valve not seized?

Yes - Go to step (8).

No - Replace valve and check valve guide. Go to step (8) if problem continues.

(8) Piston rings not broken or seized?

Yes - Go to step (9).

No - Replace rings. Check pistons and cylinders. Go to step (9) if problem continues.

(9) Piston, rings or cylinder not worn?

Yes - Go to step (10).

No - Replace pistons and rings, bore or hone cylinders. Go to step (10) if problem continues.

(10) Crankshaft pin or bearing not worn?

Symptom: Low compression

Yes - Go to step (11).

No - Grind crankshaft and replace bearings. Go to step (11) if problem continues.

(11) Piston rings installed correctly?

Yes - Go to step (12).

No - Install piston rings correctly. Go to step (12) if problem continues.

(12) Piston ring ends staggered?

Yes - Go to step (1).

No - Stagger piston ring ends. Go to step (1) if problem continues.

Symptom: Intake Manifold Pressure Low

(1) Air filter elements not clogged?

Yes - Go to step (2).

No - Clean or replace air filter elements. Go to step (2) if problem continues.

(2) Intake or exhaust valve clearance correct?

Yes - Go to step (3).

No - Adjust valve clearance. Go to step (3) if problem continues.

(3) Intake or exhaust valve not seized?

Yes - Go to step (4).

No - Replace valve and check valve guide. Go to step (4) if problem continues.

(4) Engine being run under high altitude or high temperature conditions.

Symptom: Intake Manifold Pressure High pressure

(1) Correct volume of fuel being injected?

No - Replace faulty fuel injector pump or fuel injectors.

ENGINE - 24 HP DIESEL TESTS AND ADJUSTMENTS

Tests and Adjustments

Cylinder Compression Test

Reason:

To determine the condition of the pistons, rings, cylinder walls and valves.

Equipment:

- JT01682 Compression Gauge Assembly
- JDG560 Adapter

Procedure:

1. Remove the injection nozzles.

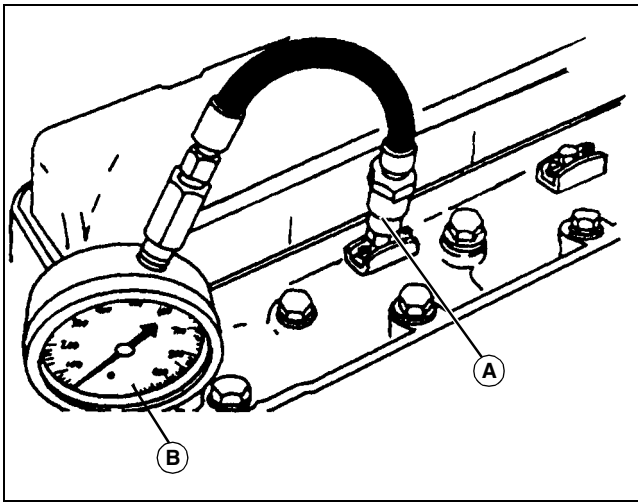

T6333EU

2. Install the heat protector from end of injector and install JDG560 adapter (A).
3. Install JT01682 Compression Gauge Assembly (B) and JDG560 Adapter.
4. Disconnect the fuel control solenoid connector.

IMPORTANT: Avoid damage! DO NOT overheat starting motor during test.

5. Crank the engine for five seconds with the starting motor. Minimum cranking speed is 250 rpm.
6. Record the pressure reading for each cylinder.

Specifications:

Cylinder Compression Pressure. . . . 3138 kPa (455 psi)
(Minimum) 2555 kPa (370 psi)
Difference Between Cylinders
(Maximum). 245 kPa (36 psi)

Results:

- If the pressure reading is below specification, perform "Radiator Bubble Test" to help determine the cause of compression loss.

Slow Idle Adjustment

IMPORTANT: Avoid damage! The slow idle adjustment is the only adjustment that can be made on this engine.

The fast idle and torque capsule adjustments are pre-set by the engine manufacturer to comply with strict EPA/ARB emissions requirements, and are adjustable ONLY by authorized diesel service facilities.

Reason:

To achieve proper slow idle rpm setting. Provides adequate rpm to keep the engine running smoothly without stalling.

Equipment:

- JT05719 Hand Held Digital Tachometer

NOTE: Make sure the air cleaner is clean and not restricted. Replace the air cleaner element as necessary.

Procedure:

1. Place a small piece of reflective tape on the crankshaft pulley.
2. Start the engine and run for 5 minutes to attain operating temperature.
3. Move the throttle lever to slow idle position.
4. Use JT05719 Hand Held Digital Tachometer to check engine speed at the crankshaft pulley.
5. Visually check that the injection pump throttle lever is against slow idle stop screw. Slow idle speed is set to specification.

Specifications:

HST Machines. 1000 ± 50 rpm

ENGINE - 24 HP DIESEL TESTS AND ADJUSTMENTS

Results:

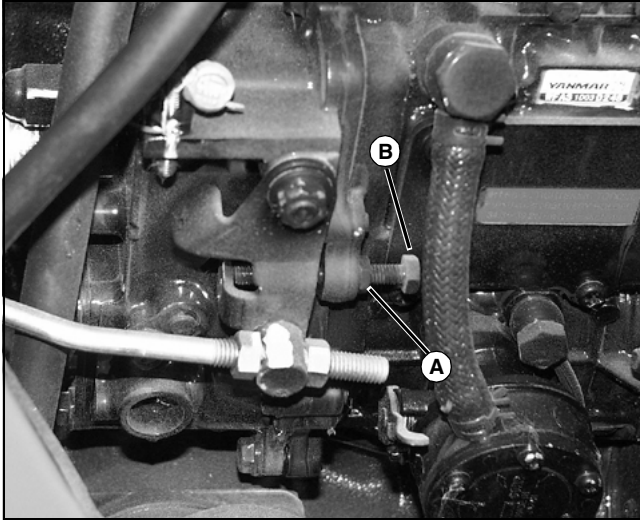

MX14415

- If the slow idle rpm is not according to specifications, loosen the jam nut (A) and turn the slow idle stop screw (B) clockwise to increase the engine speed, or counterclockwise to decrease the engine speed until the slow idle speed is correct. After adjustment, tighten the jam nut.

Valve Clearance Adjustment

Reason:

To be sure the valves are fully opening and closing at the correct time, and not wearing the valve train unnecessarily.

Equipment:

- Feeler Gauge
- 10 mm End Wrench
- Flat Blade Screwdriver
- 17 mm Wrench

Procedure:

1. The engine must be cool (room temperature) before the valve clearance is checked.
2. Be sure ignition key is OFF before attempting to turn engine by hand.
3. Open the hood and remove the engine side covers.
4. Remove the rocker arm cover. See "Rocker Cover Removal and Installation" on page 157.

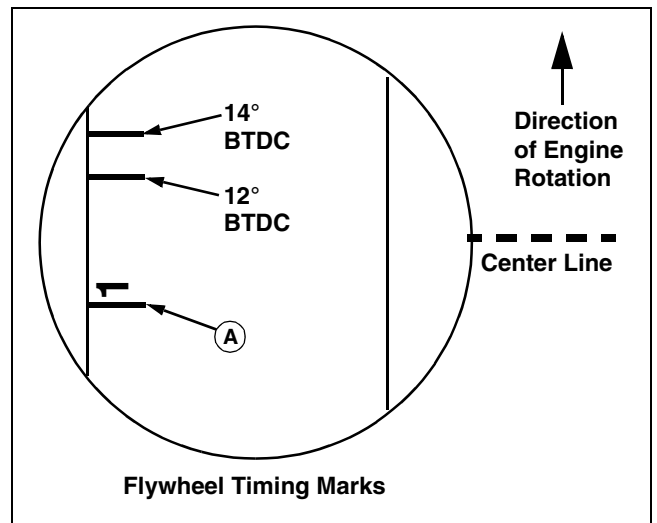

MIF

5. Locate the inspection hole in right side of the transmission tunnel. The flywheel can be seen inside the inspection hole.

NOTE: "Top dead center (TDC)" is when the piston is at its highest point of travel in the cylinder on the compression stroke. Number one cylinder is located at rear of engine (flywheel side).

6. Turn the crankshaft pulley while watching the flywheel inside the inspection hole. Align the number one TDC mark (A) on the flywheel with the pointer on the tunnel.

NOTE: When top dead center is reached, the rocker arms for that cylinder will be motionless as the crankshaft is rotated. If rocker arms are still moving when TDC is approached, rotate crankshaft one full revolution and try again.

7. Try to move rocker arms and/or push rods for No. 1 cylinder:

- If the rocker arms and push rods are loose, the piston is at TDC on the compression stroke. Go to step 8.
- If the rocker arms and/or push rods are not loose, rotate the flywheel one revolution (360°), and recheck the rocker arms and push rods.

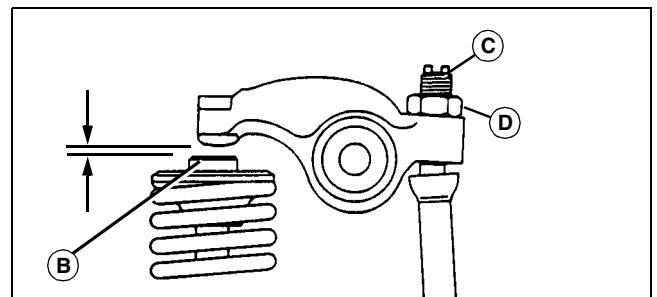

MX1194

8. Slide a feeler gauge between the valve cap (B) and rocker arm to measure the clearance.

ENGINE - 24 HP DIESEL TESTS AND ADJUSTMENTS

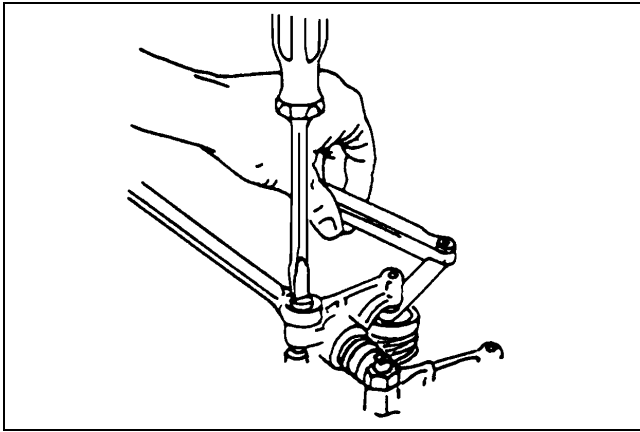

T6105BF

9. To adjust the valves, loosen the lock nut (D) and turn the adjusting screw (C) until the blade of the feeler gauge can be inserted between the rocker arm and valve cap. Hold the adjusting screw while tightening the lock nut.

10. Recheck the valve clearance after tightening the lock nut.

Specification:

Valve Clearance 0.15 - 0.25 mm (0.006 - 0.010 in.)

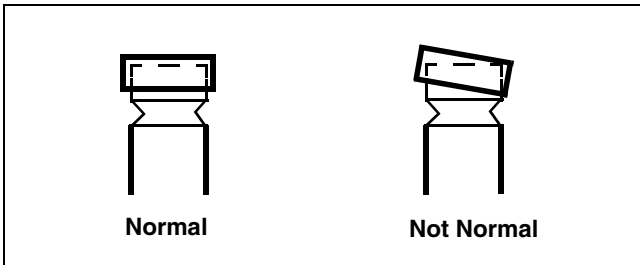

MIF

11. Check that the valve cap on the valve stem remained seated on the valve and inside the valve spring retainer.

12. Turn the crankshaft pulley counter clockwise (as viewed from operator's seat or flywheel end) approximately 2/3 of a revolution (240°) while watching the observation hole for the number three timing mark.

13. Check that the rocker arms and push rods for cylinder number three are loose.

14. Repeat steps 7 - 13 for number three cylinder.

15. Repeat steps 7 - 11 for number two cylinder.

16. Replace the rocker arm cover, air cleaner bracket and housing, and the muffler.

17. Replace the engine side covers and hood.

Valve Lift Check

Reason:

Check wear on cam lobes, followers, and/or push rods.

Equipment:

- Dial Indicator

Procedure:

1. Remove the rocker arm cover. See "Rocker Cover Removal and Installation" on page 157.
2. Adjust the valve clearance.

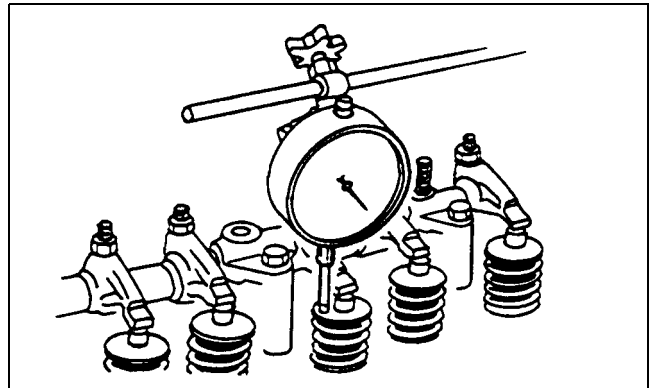

T6333DT

3. Fasten the dial indicator to the engine and position the indicator tip on the valve retainer. The valve must be fully closed and the rocker arm must move freely.
4. Zero the dial indicator.
5. Manually turn the crankshaft pulley clockwise (from the fan end).
6. Observe the dial indicator as the valve is moved to the full open position. Repeat for each valve.

Results:

- The valve lift should be the same for all valves. If one or more valves have less travel than the others, remove and inspect the camshaft, followers and push rods. See "Camshaft" on page 177. If the camshaft, followers and push rods are within specification remove and inspect the cylinder head. See "Cylinder Head and Valves Removal and Installation" on page 159.



Suggest:

If the above button click is invalid.

Please download this document first, and then click the above link to download the complete manual.

Thank you so much for reading

ENGINE - 24 HP DIESEL TESTS AND ADJUSTMENTS

Fuel Injection System Tests



CAUTION: Avoid Injury! Escaping fluid under pressure can penetrate the skin causing serious injury. Avoid the hazard by relieving pressure before disconnecting high pressure lines. Tighten all connections before applying pressure. Search for leaks with a piece of cardboard. Protect hands and body from high pressure fluids.

If an accident occurs, see a doctor immediately. Any fluid injected into the skin must be surgically removed within a few hours or gangrene may result. Doctors unfamiliar with this type of injury should reference a knowledgeable source. Such information is available from the Deere & Company Medical Department in Moline, Illinois, U.S.A.

Reason:

To stop fuel flow to the cylinders (one at a time), while engine is running, to determine what effect that cylinder has on overall engine performance.

Equipment:

- (2) 17 mm Open End Wrenches

Procedure:

1. Park machine on level surface, park brake locked, transmission in NEUTRAL, power-take-off OFF.
2. Open hood and remove engine side covers and air cleaner.



CAUTION: Avoid Injury! This test will cause diesel fuel to be released from fuel system. Injection pump is capable of producing extremely high pressure. Eye protection must be worn. Do not open fuel injector connectors more than 1/8 of a turn. Do not place hands near injectors during test. Do not allow any debris to enter intake manifold during test. Do not smoke.

3. Start engine and run at slow idle.

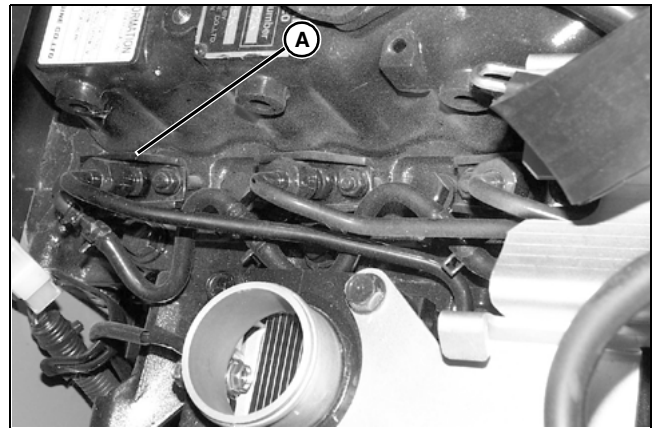

MX14416

4. Using a 17 mm open end wrench, loosen one of the injector line nuts (A) 1/8 of a turn (45°).
5. Listen for engine speed to drop and exhaust noise to change.
6. Tighten nut and allow engine to return to original speed before loosening next cylinder's injector line nut.
7. Compare sound and speed of each cylinder as it is disabled.
8. Tighten injector line nuts and stop engine.

Results:

- When fuel flow is stopped to a cylinder, engine rpm should drop, engine should begin to vibrate and run rough, and exhaust noise will be uneven until fuel flow is restored.

If test produces the results described above, but engine performance remains poor, test the following:

- Clogged air cleaner elements, leaking air filter outlet hoses or clamps.
- Restriction in exhaust system.
- Presence of coolant or diesel in crankcase oil.

If defeating a single cylinder has no effect on overall engine performance, test the following:

- Fuel injector nozzle opening pressure, spray pattern, and leakage and for that cylinder. See "Fuel Injection Nozzle Test" on page 142.
- Cylinder compression or cylinder leakage test.
- Fuel supply pump pressure.
- Fuel shutoff solenoid is opening fully.
- Fuel control and governor linkage flyweights allowing full fuel flow to injector pump.
- Injection pump timing correct.

If the above test results are within specifications, remove injection pump and have tested at an Authorized Diesel Service (ADS) Center.

<https://www.ebooklibonline.com>

Hello dear friend!

Thank you very much for reading.

Enter the link into your browser.

The full manual is available for immediate download.

<https://www.ebooklibonline.com>