

# **3210, 3310, 3410, 3210X, 3310X and 3410X Tractors**

## **TECHNICAL MANUAL Tractors 3210, 3310, 3410, 3210X, 3310X and 3410X Repair and Operation and Tests**

**TM4663 02FEB02 (ENGLISCH)**

**John Deere Werke Mannheim**

Printed in Germany

## Recognize Safety Information

This is a safety-alert symbol. When you see this symbol on your machine or in this manual, be alert to the potential for personal injury.

Follow recommended precautions and safe operating practices.

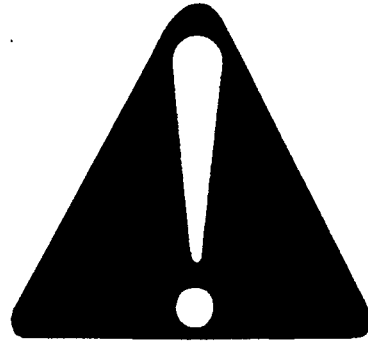

DX,ALERT -19-29SEP98-1/1

TS1389 -UN-07DEC88

## Understand Signal Words

A signal word—DANGER, WARNING, or CAUTION—is used with the safety-alert symbol. DANGER identifies the most serious hazards.

DANGER or WARNING safety signs are located near specific hazards. General precautions are listed on CAUTION safety signs. CAUTION also calls attention to safety messages in this manual.



DX,SIGNAL -19-03MAR93-1/1

TS187 -19-30SEP88

## Follow Safety Instructions

Carefully read all safety messages in this manual and on your machine safety signs. Keep safety signs in good condition. Replace missing or damaged safety signs. Be sure new equipment components and repair parts include the current safety signs. Replacement safety signs are available from your John Deere dealer.

Learn how to operate the machine and how to use controls properly. Do not let anyone operate without instruction.

Keep your machine in proper working condition. Unauthorized modifications to the machine may impair the function and/or safety and affect machine life.

If you do not understand any part of this manual and need assistance, contact your John Deere dealer.



DX,READ -19-03MAR93-1/1

TS201 -UN-23AUG88

10  
05  
2

### Mount and Dismount the Machine Safely

Always use the access steps and handrails when mounting and dismounting the tractor.

Ensure that the access steps and operator's station are kept clean at all times. This will help prevent accidents.



TS279 -UN-23AUG88

FD,HANDLE -19-01APR94-1/1

### Prevent Machine Runaway

Avoid possible injury or death from machinery runaway.

Do not start engine by shorting across starter terminals. Machine will start in gear if normal circuitry is bypassed.

NEVER start engine while standing on ground. Start engine only from operator's seat, with transmission in neutral or park.

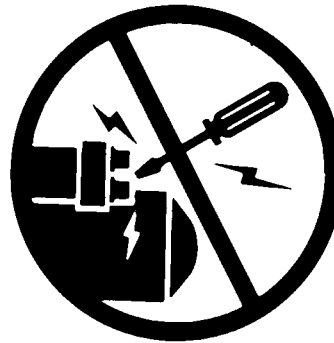

TS177 -UN-11JAN89

DX,BYPAS1 -19-29SEP98-1/1

### Use Seat Belt Properly

Use a seat belt when you operate with a roll-over protective structure (ROPS) or cab to minimize chance of injury from an accident such as an overturn.

Do not use a seat belt if operating without a ROPS or cab.

Replace entire seat belt if mounting hardware, buckle, belt, or retractor show signs of damage.

Inspect seat belt and mounting hardware at least once a year. Look for signs of loose hardware or belt damage, such as cuts, fraying, extreme or unusual wear, discoloration, or abrasion. Replace only with replacement parts approved for your machine. See your John Deere dealer.

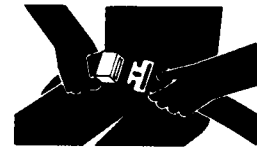

TS205 -UN-23AUG88

DX,ROPS1 -19-07JUL99-1/1

**<https://www.ebooklibonline.com>**

Hello dear friend!

Thank you very much for reading.

Enter the link into your browser.

The full manual is available for immediate download.

**<https://www.ebooklibonline.com>**

## Work In Ventilated Area

Engine exhaust fumes can cause sickness or death. If it is necessary to run an engine in an enclosed area, remove the exhaust fumes from the area with an exhaust pipe extension.

If you do not have an exhaust pipe extension, open the doors and get outside air into the area

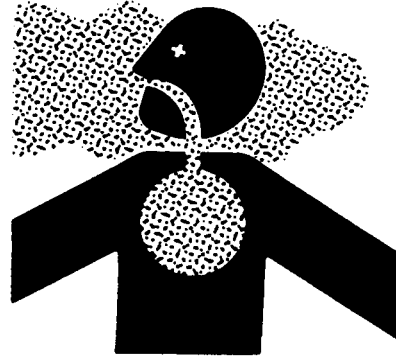

DX,AIR -19-17FEB99-1/1

TS220 -JN-23AUG88

10  
05  
3

## Driving the Tractor Safely

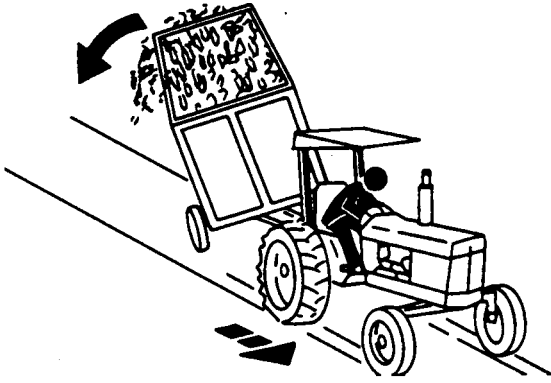

TS216 -JUN-23AUG88

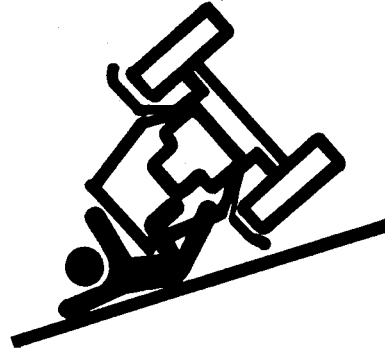

RW13093 -JUN-07DEC88

Always check the road and general operating safety of the machine before using.

Operate tractor only when all guards are fitted and in their correct position.

Before moving away, always check immediate vicinity of machine (e.g. for children). Ensure adequate visibility.

To limit the risks of overturning, set the tread width to the maximum suitable for the task. Comply with regulations restricting maximum width.

Make sure the tractor is ballasted properly for its intended task.

Always adapt your ground speed to meet the ground conditions. Avoid making sharp turns when driving up or down slopes or when driving across the slope. Do not attempt to turn the machine with the differential lock engaged. Reduce your ground speed when driving the tractor on slopes or over uneven ground and before making sharp turns. Before descending a steep hill, shift to a lower gear. When driving down slopes, never depress the clutch and change gear; use the same gear you would use to drive up the slope. Never coast downhill.

When making turns with towed or mounted implements, always take into consideration the width and inertia of the implement.

Avoid holes, ditches and obstructions which may cause the tractor to tip, particularly on hillsides. Never drive near the edge of a gully or steep embankment — it might cave in!

Front-wheel drive greatly increases traction. This means that the tractor can be driven on steeper slopes, increasing the possibility of a tip over. Driving forward out of a ditch or up a steep slope could cause tractor to tip over to the rear. Therefore reverse out of these situations whenever possible.

### Driving on Public Roads

It is vital to comply with road traffic regulations.

Before driving the tractor on a public road, make sure that the lights, turn signals and brake lights are functioning correctly. Never switch on the work lights while driving on public roads. The brake pedals must be coupled together. Never apply the differential lock when driving on a road.

When transporting mounted implement(s), raise the rockshaft. If the implement is equipped with road wheels, use them.

### Towing Implements or Trailers

Attach implements and trailers to the tractor only using the prescribed drawbars or hitches. Attach trailers and implements correctly. Always ensure that trailers and implements cannot roll away. If trailer brakes are equipped, use them!

Braking to stop towed loads from transport speeds can cause the towed load to swerve and upset. Reduce speed if towed load weighs more than the tractor and is not equipped with brakes.

FD\_DRIVE -19-02JUN94-2/2

### Operating the Tractor Safely



TS213 -UN-23AUG88



TS276 -UN-23AUG88

Careless use of the tractor can result in unnecessary accidents. Be alert to hazards of tractor operation. Understand causes of accidents and take every precaution to avoid them. Most common accidents are caused from:

- Tractor roll-over
- Improper starting procedures
- Crushing and pinching during hitching
- Collisions with other motor vehicles
- Entanglement in PTO shafts
- Falling from tractor

Avoid accidents by taking the following precautions:

Put transmission in PARK before dismounting. Leaving transmission in gear with engine stopped will NOT prevent the tractor from moving.

Be sure everyone is clear of tractor and attached equipment before starting engine.

Never try to get on or off a moving tractor.

When tractor is left unattended, place in PARK, lower implements to the ground, stop the engine, and remove the key.

Never go near an operating PTO or an operating implement.

Always fasten your seat belt in a ROPS equipped tractor.

RX\_HAZARD.S -19-20DEC95-1/1

10  
05  
6

## Keep Riders Off Machine

Only allow the operator on the machine. Keep riders off.

Riders on machine are subject to injury such as being struck by foreign objects and being thrown off the machine. Riders also obstruct the operator's view resulting in the machine being operated in an unsafe manner.

On machines equipped with a passenger seat, one rider is permitted.

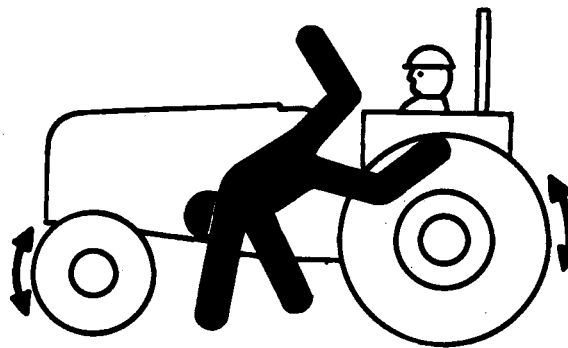

TS290 -UN-23AUG88

LX,OMITF 002146 -19-01FEB92-1/1

## Parking and Leaving the Tractor

Lower mounted implement(s) or equipment to the ground before leaving the tractor.

When leaving the tractor and/or implements, shut off engine, engage range and gear shift levers as well as handbrake and parking lock, remove main switch key and lock the operator's cab (if equipped). Put chock blocks in position.

Never leave tractor unattended while the engine is still running.

Never leave the operator's platform/cab when driving.

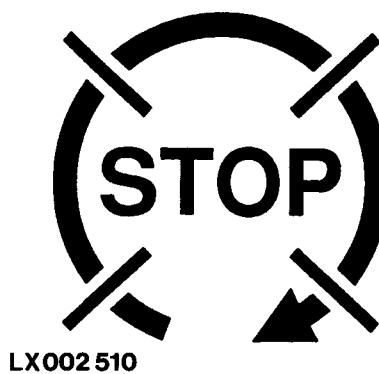

LX002510 -UN-17JAN95

LX,PARK -19-07DEC96-1/1

# Disassembly - Assembly

## Cylinder head

### • Removal

Remove the intake and exhaust manifolds.  
Remove the injectors using special tool No.5503 (1).

**Note:** The injectors must be removed in order to prevent from damaging them when removing the cylinder head.

**Mark all the parts before removing them, in order to help assembly in their initial location.**

Remove the rocker arm assembly.  
Remove the cylinder head fitting bolts, and remove the cylinder head.

**IMPORTANT:** After removing the cylinder head, turn the crankshaft only after blocking all the liners (C) using bolts (A) and washers(B).

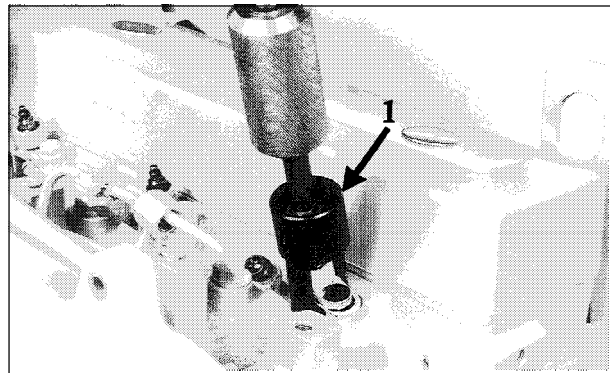

A2-023

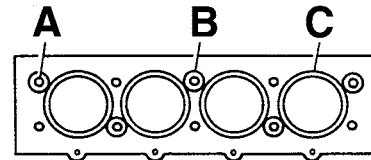

A2-025



A2-024

### • Cleaning the injector housings

Remove the carbon deposit in the injector housings using tool No.5519 (2).

**IMPORTANT:** Always turn the tool clockwise, even when removing it, in order to prevent from blunting it.

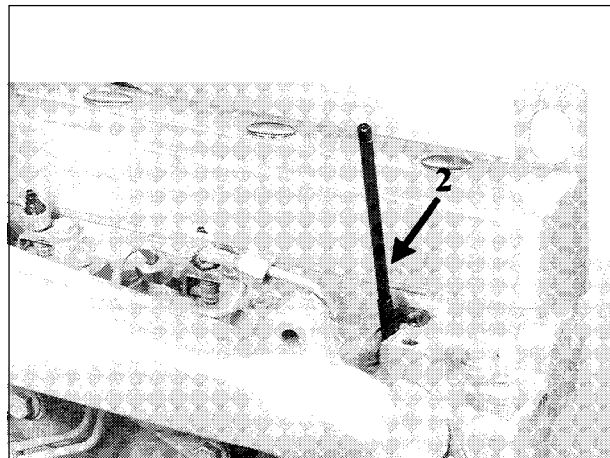

A2-026

## Disassembly - Assembly

### •Removing the valves and theirs springs

- 1 - Compress the valve springs with compressor tool No. 8131 (1) to remove the half-cones (A).

**Note:** on the local level, build the part (2) using a washer and a bolt with specifications identical to that of a rocker arm pump securing screw.

**Bolt reference:** 6005 021 506.

- 2 - Loosen the tension on the springs; remove the rotators (B) and the valve springs (C). Mark each element in order to reassemble it in its respective location.
- 3 - Remove the valves; mark them for reassembly.
- 4 - Remove the valve stem seals (D) from the valve guide shoulders.

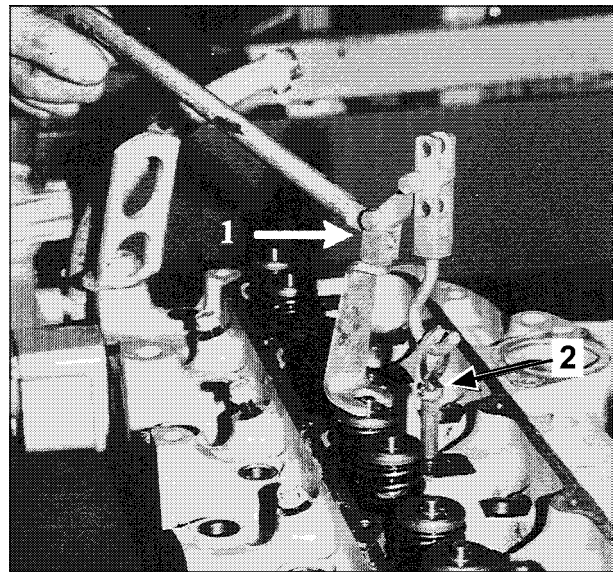

A2-027

### • Checking the cylinder head gasket plane

The maximum distortion defect is 0.08 mm.

In case of major distortion, rectify the cylinder head gasket face.

**Note:** The cylinder head gasket face can be rectified by 0.76 mm maximum.

**Always check valve withdrawal after rectifying the cylinder head.**

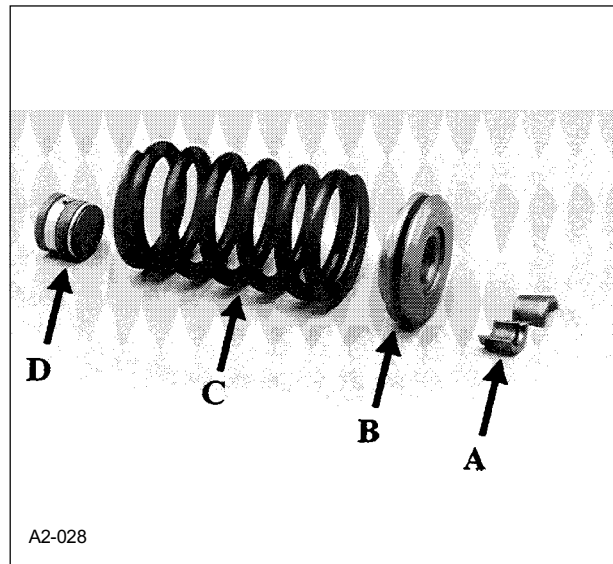

A2-028

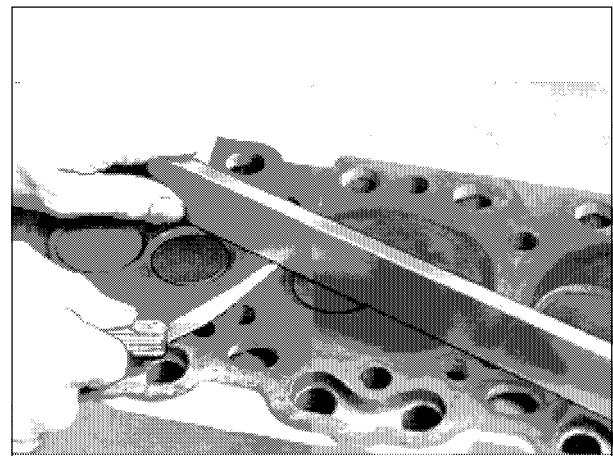

A2-029

## Disassembly - Assembly

### • Reassembly of the cylinder head

- 1 - Clean the threaded holes on the cylinder block using the special tap No.5517 (1). Remove any dust and liquid residue using compressed air.
- 2 - Lubricate the rockers (3) on the camshaft before reinstalling them in their housings.
- 3 - Fit a new dry cylinder head seal (no sealing compound).

**IMPORTANT:** Check that all rockers are in place before fitting the cylinder head.

- 4 - Insert two centring studs in the housings (A).

**Note:** On the local level, build 2 centering studs using 2 bolts ref. 6005 012 886.

**IMPORTANT:** If the centering studs are not fitted in place, the O-ring crimped in the cylinder head seal (passage of lubrication oil from the carburettor ramp) may be damaged when the cylinder head is moved onto the engine block to align the bolt bores.

- 5 - Fit the cylinder head correctly on the centring studs, and lower it onto the cylinder block.

### • Tightening method

- 1 - Before assembly, apply a SMALL amount of graphite grease onto the threads and under the heads of each bolt.
- 2 - Remove the centring studs and fit all the cylinder head bolts.
- 3 - Tighten the cylinder head bolts at the tightening torque specified, according to the sequence indicated, starting with bolt No.1.
  - 1<sup>st</sup> stage - Tighten all the bolts to 10 daN.m.
  - 2<sup>nd</sup> stage - Tighten all the bolts to 15 daN.m.
  - 3<sup>rd</sup> stage - Wait 5 minutes and check that all the bolts are tightened at 15 daN.m.
  - 4<sup>th</sup> stage - Apply to each bolt an additional angle of  $60^\circ \pm 10^\circ$ .

A - Centring stud housing  
B - Front of the engine

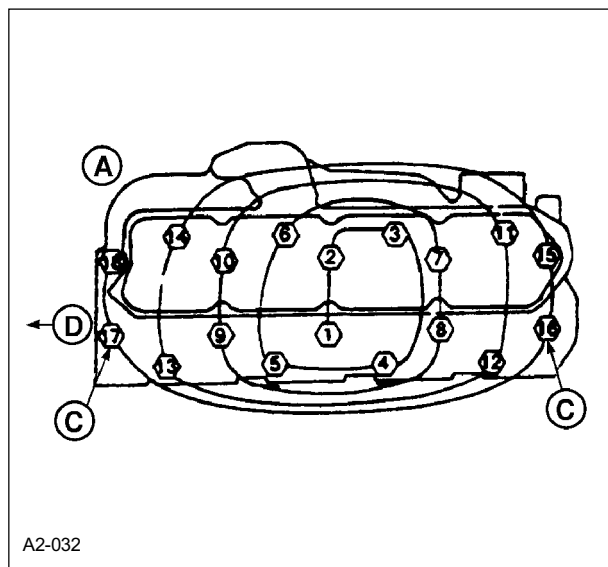
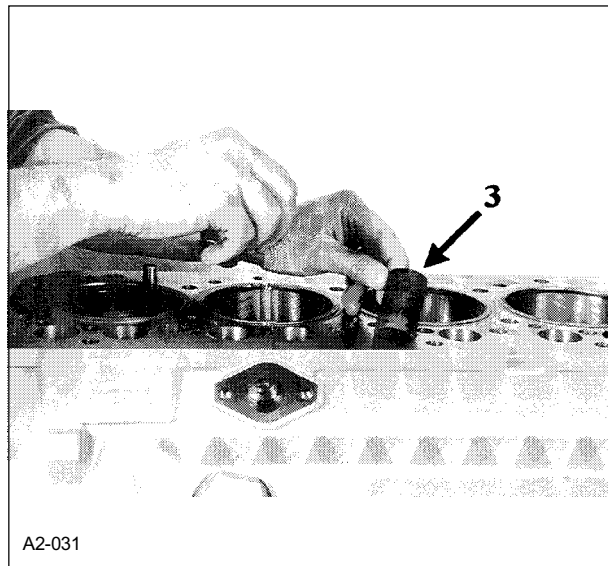
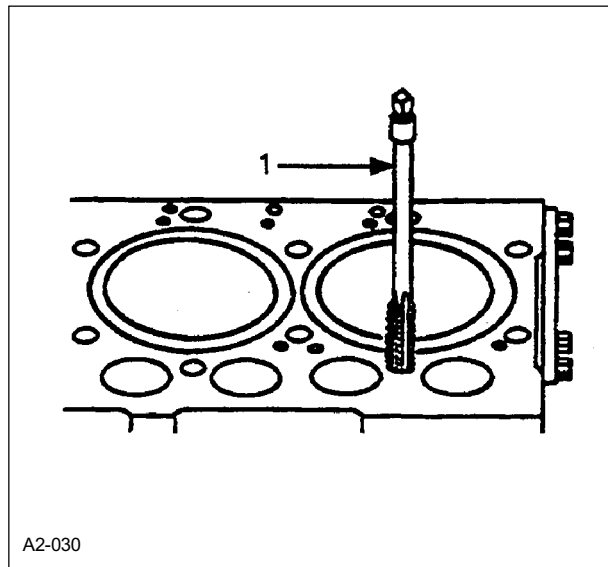

## Disassembly - Assembly

### • Angular tightening method

To ensure that the 60° angle is achieved (4<sup>th</sup> stage), proceed as follows:

#### • Step A

Scribe a first mark on the socket and a second at 60° from the first anti-clockwise.

#### • Step B

Scribe a mark on the cylinder head opposite each bolt.

#### • Step C

Fit the socket onto the bolt while ensuring that the first mark is aligned with the reference mark on the cylinder head.

#### • Step D

Tighten all the bolts (in sequence) until the second mark on the socket is aligned with the mark on the cylinder head.

**IMPORTANT: The angular tightening method eliminates the obligation to retighten the cylinder head bolts after the first hours of service.**

A - Reference mark

B - Mark at 60°

### • Reassembling the rocker arm (only after reassembling the cylinder head)

1 - Assemble the rocker stems in their original position.

**Note: The ends of the valve stems are hardened; therefore, fitting protection caps is unnecessary.**

2 - Assemble the rocker arm on the engine.

**IMPORTANT: Align the orifice (C) on the rocker arm with the lubrication orifice (D) on the cylinder head.**

3 - Lubricate all the rockers with engine oil.

4 - Tighten the securing studs at 6 daN.m.

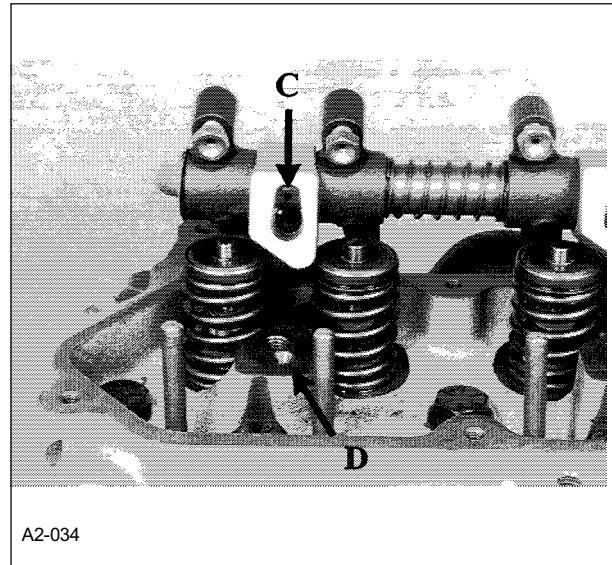
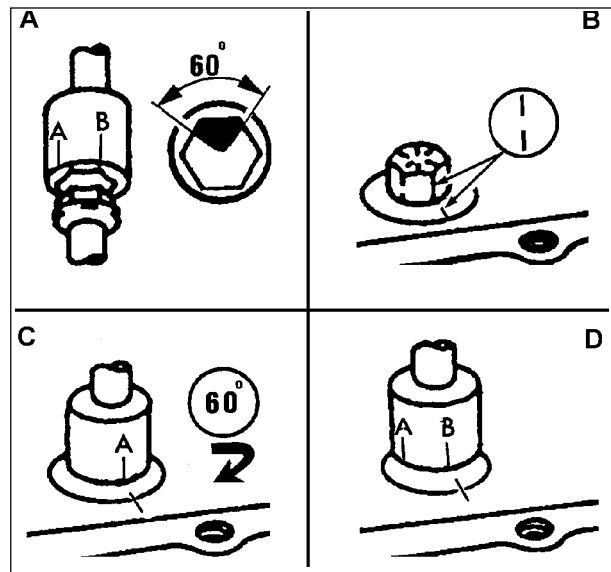

## Disassembly - Assembly

### Camshaft

#### • Removing the camshaft

**Note:** Removing the cylinder head from the engine is not required to remove the camshaft.

- 1 - Remove the rocker arm and stems.
- 2 - Remove the distributor casing.
- 3 - Turn the engine gear train until the bolts (A) can be removed.
- 4 - Using a wire (C) push the rockers through all the lubrication bores located on the rockers.

**IMPORTANT:** If the camshaft rockers fall into the engine casing, you must remove the cylinder head.

- 5 - Remove the support plate (D) from the slot located behind the camshaft pinion.
- 6 - Slowly extract the camshaft to extract it from the cylinder block.
- 7 - Clean the camshaft, then inspect the camshaft cams and bearings. If required, change the camshaft.

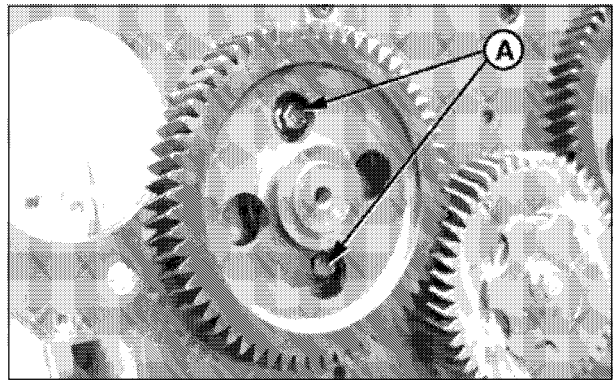

A2-195

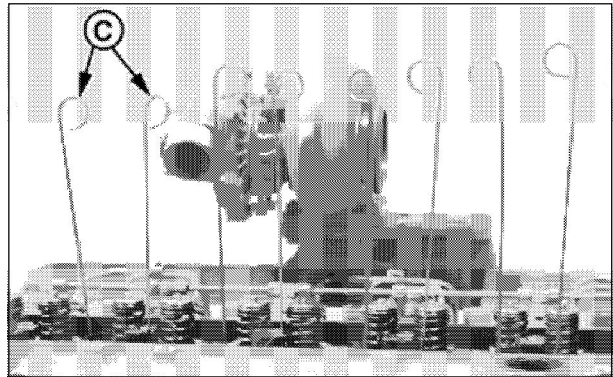

A2-197

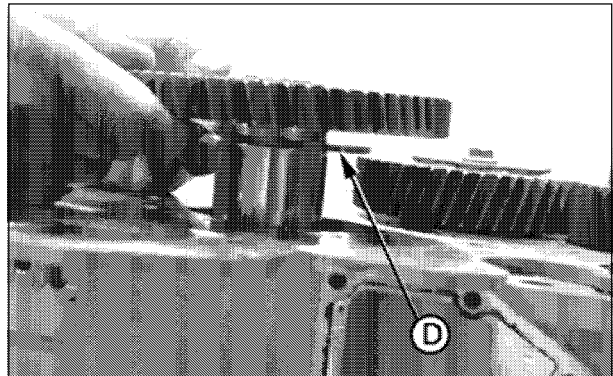

A2-198

# Disassembly - Assembly

## Cylinder block

### • Changing the camshaft bush

#### Disassembly

- 1 - Remove the camshaft.
- 2 - Remove the Torx bolt (A) and fit the taper end stud (B) of the tool No.5531.
- 3 - Install the 2 other flat end studs (C) from tool No. 5531 and the disassembly/assembly plate (D) of tool No.5520.
- 4 - Insert the bush extractor (E) from tool No.5520 into the camshaft bore as shown in the photo.
- 5 - Tighten the hex head nut (F) until the bush is released from the bore.
- 6 - Clean and inspect the bush bore. If the bore is damaged, change the cylinder block.

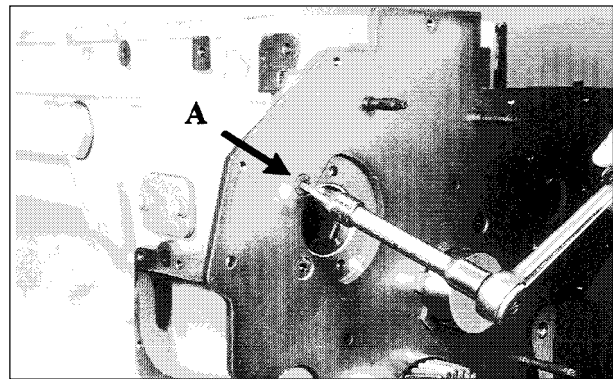

A2-036

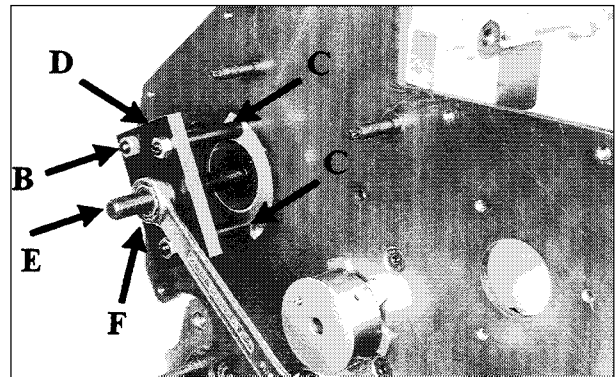

A2-037

#### Reassembly

**IMPORTANT:** Fit the bush while ensuring that all lubrication holes in the bush and the cylinder block are opposite each other.

- 1 - Mark the orientation of the lubrication holes (G) on the front face of the block and on the bush, in order to facilitate alignment of the bushes during installation.
- 2 - Apply high temperature grease on the inside/ outside diameters of the new bush, and on the inside diameter of the bore in the block.
- 3 - Fit the tool in place with the bush as shown in the picture. With the bush (J) engaged, tighten the screw (H) until the flange (K) contacts the cylinder block face.
- 4 - Remove the tool and check for proper alignment of the lubrication hole. If the holes are not aligned, remove and discard the bush. Fit a new bush.

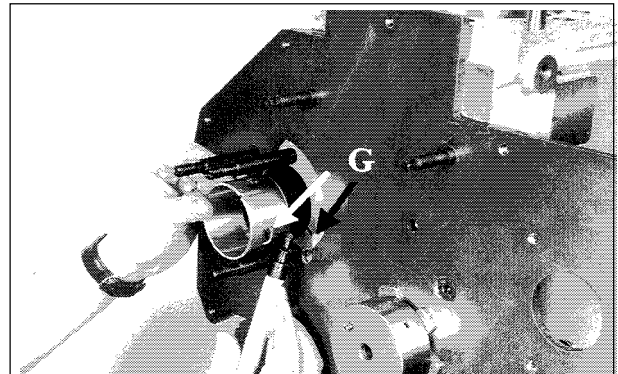

A2-038

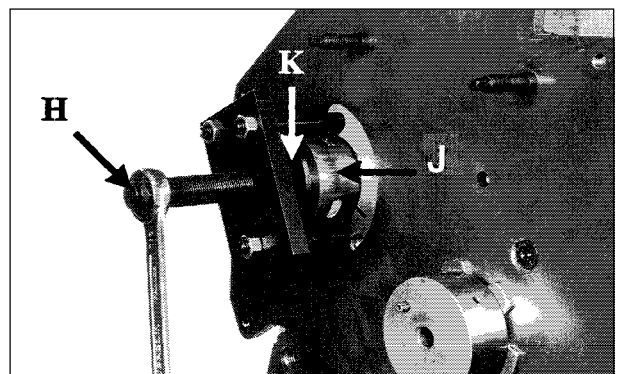

A2-039

# Disassembly - Assembly

## Liners

### • Disassembling the liners

**IMPORTANT:** Before disassembly, number the liners and the pistons. Mark the part **BEFORE** the liner is removed in order to ensure its proper reassembly position.

Extract the liners from the cylinder block using the tool No.5504 (1).

**IMPORTANT:** After removing the cylinder head, never turn the crankshaft unless all the liners are blocked (C) using bolts (A) and washers (B).

### • Checking the ovalization and tapering of the liners

Measure the liner bores at four different points in the piston ring stroke range.

- Liner bore: 106.48 - 106.52 mm.
- Piston/liner clearance, measured at the bottom of the rim: 0.09 - 0.14 mm.
- Maximum cylinder ovalization (top and bottom): 0.05 mm.
- Maximum cylinder taper: 0.05 mm.

If the geometry of the cylinder liner does not comply with specifications, change the piston and the liner.

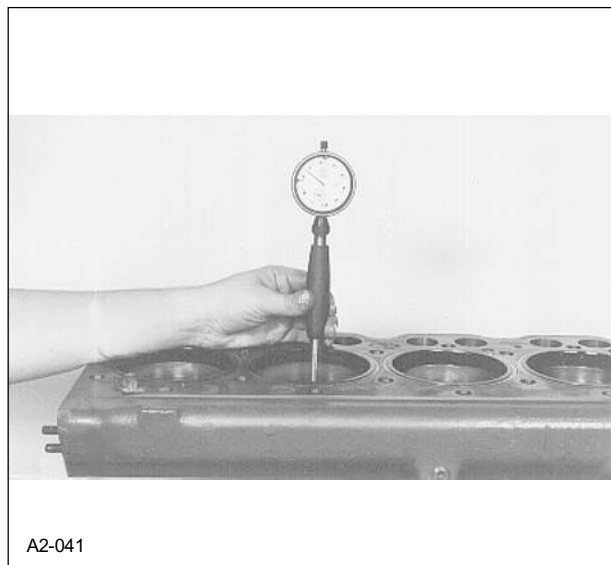
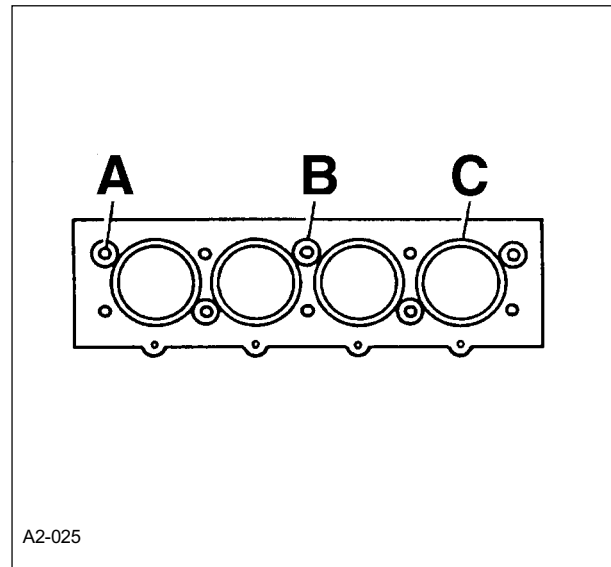
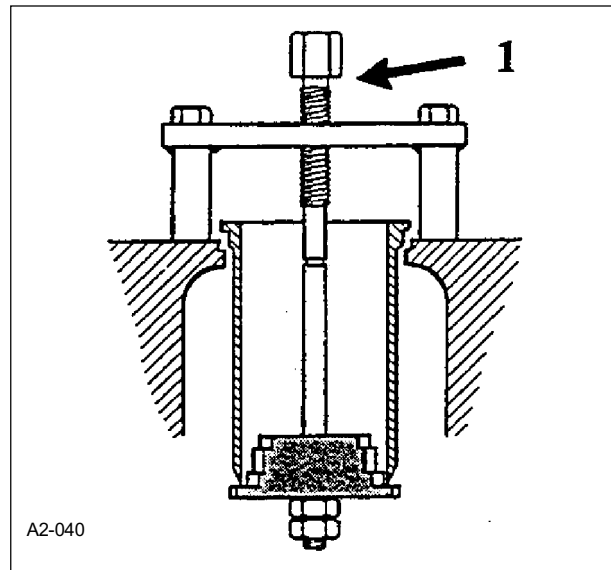

## Disassembly - Assembly

### • Measurement of the liner protrusion

**IMPORTANT:** First fit the liners without seals to check liner protrusion. When correctly installed, the liners can be rotated easily by hand. If not, remove the liners and polish the lower liner guide in order to achieve frictionless rotation of the liners.

- 1 - Fit the liners without seals and secure them in four points; tighten the bolts to 7 daN.m.
- 2 - Measure the protrusion of the liners, using the checking tool No.8120 (1).
  - Calibrate the control tool
    - Fit the calibrating rule under the base.
    - Calibrate the comparator to zero.
    - Remove the rule.
  - Fitting the control tool.
    - Position the control tool on the cylinder to check.
  - Measure the liner overlapping in 4 points.

### LINER PROTRUSION CHARACTERISTICS

Liner protrusion: 0.03 mm - 0.10 mm.

Maximum acceptable tolerance between two adjacent liners: 0.05 mm.

- 3 - If the overlap or the tolerance differ from the values indicated, smear abrasive paste on the cylinder block shoulder (2) supporting the liner flange (3), fit the liner, and turn to the right and left until achieving proper overlapping (to this effect, use the special tool No.5504).
- 4 - If the overlap is insufficient, fit a shim under the flange. Two thicknesses of shims are available: 0.05 and 0.10 mm.

**IMPORTANT:** USE ONLY ONE SHIM PER CYLINDER. If a liner requires more than one shim, fit a new liner or a new cylinder block.

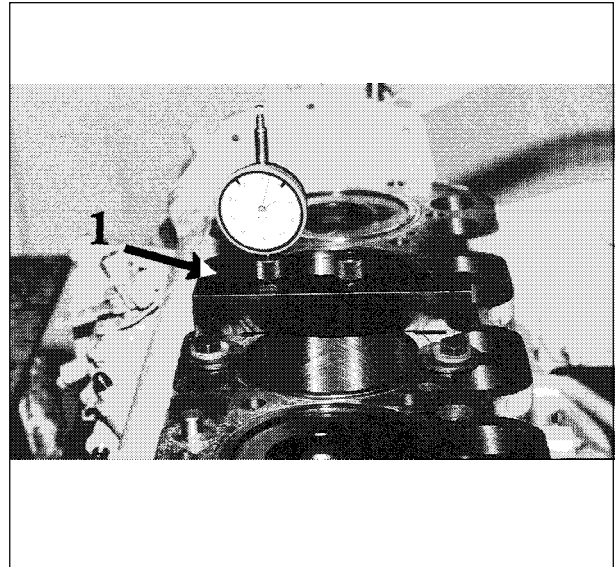

A2-042

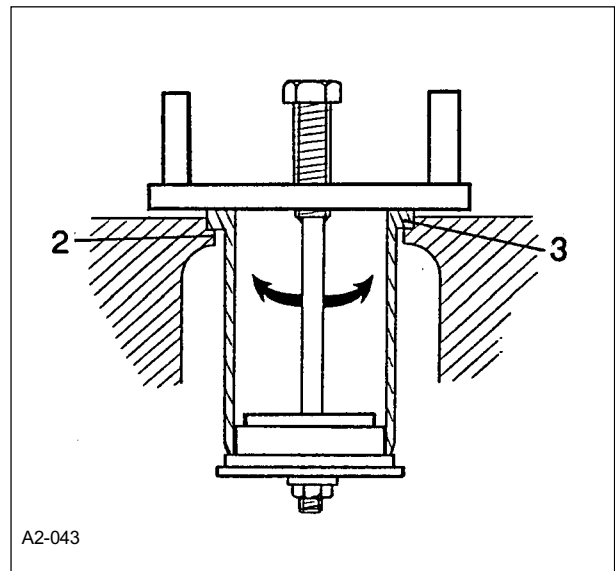

A2-043

## Disassembly - Assembly

### • Fitting the rectangular section seal

Smear the new seal with soap, slide it onto the liner until it is supported on its shoulder. The seal must be compressed at minimum 0.13 mm.

- 1 - Liner
- 2 - Rectangular section seal
- A - Incorrect fitting
- B - Correct fitting

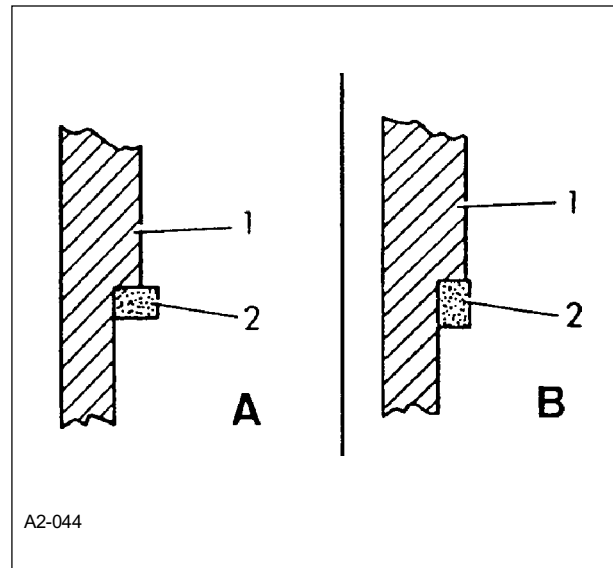

### • Fitting liner O-rings

Smear the new O-rings with soap and fit them in their respective grooves.

- A - Rectangular section seal
- B - Red and white O-ring
- C - Black O-ring
- D - Liner
- E - Cylinder block

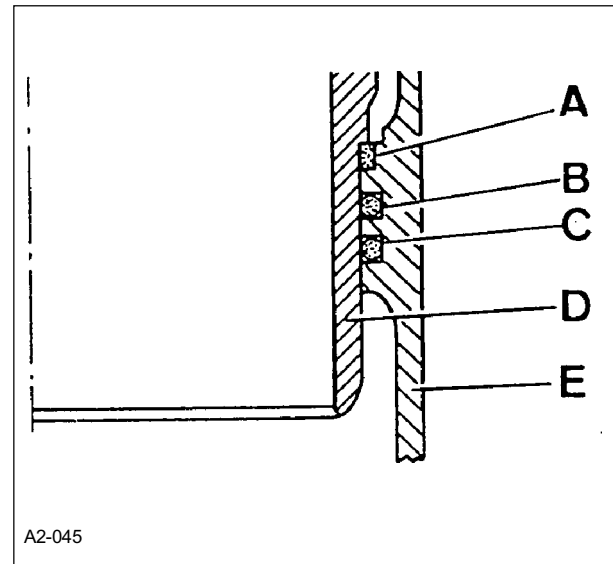

### • Reassembling the liners

Slide the liner with the shim and the rectangular section seal in its housing in the cylinder block. Seat the liners using the tool No.5504 (1). Block the liners with the large washers and the bolts.

**IMPORTANT:** When reassembling, match the marks scribed before removing the liners.

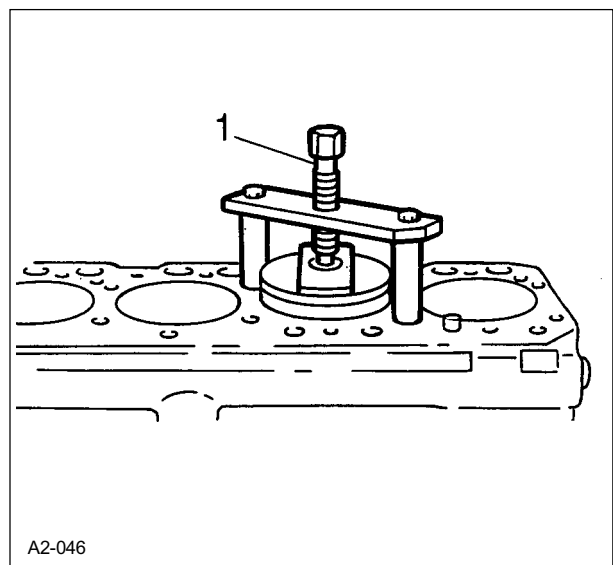

# Disassembly - Assembly

## Pistons and connecting rods

Before disassembling, mark the connecting rod and the cap with the cylinder the connecting rod is fitted to.

### •Changing connecting rod bushes

#### TRT 51 engines

Use the tool No. 5532 for a 41 mm pin.

#### Disassembly

- 1 - Fit on one of the ends of the connecting rod bush the extractor shaft (A). Turn the shaft (A) until the tapered parts of the shaft are parallel with the tapered parts of the bush (C).
- 2 - Opposite the extractor shaft (A), install the receiver plate (B).
- 3 - Using a hydraulic press, (c) press the bush from the connecting rod until the extractor shaft (A) falls into the receiving plate (B).

**IMPORTANT:** If the bush is badly worn out, the extractor shaft (A) can contact the inside diameter of the connecting rod bore. When extracting the bush, ensure you do not damage the connecting rod bore.

- 4 - Clean, inspect, and measure the inside diameter of the connecting rod pin bore.

#### Reassembly

- 1 - First slide the bush (C) on the shaft (A), then the part (D). Apply grease on the outside diameters of the bushes (C) and (D), as well as in the connecting rod bore.
- 2 - Insert the shaft (A) into the connecting rod pin bore, ensuring that the pilot bush (D) is guided in the connecting rod bore, and that the taper of the bush (C) is aligned with the taper of the shaft (A).
- 3 - Install the receiving plate (B) on the other end of the connecting rod.
- 4 - Using a hydraulic press, push the bush into the connecting rod bore, until the rim is flush or just under the connecting rod face.

#### TRT 50 - DRT 50 - DRT 51 engines

Use the tool No. 5505 for a 35 mm pin.

- 1 - Push the connecting rod bush out using the tool (1)
- 2 - Fit the new bush using the same tool.
- 3 - Bore the new bush in order to enable the insertion of the piston pin by pushing it with your thumb.

**IMPORTANT:** Check that the bush lubrication orifice (A) is aligned with the connecting rod's.

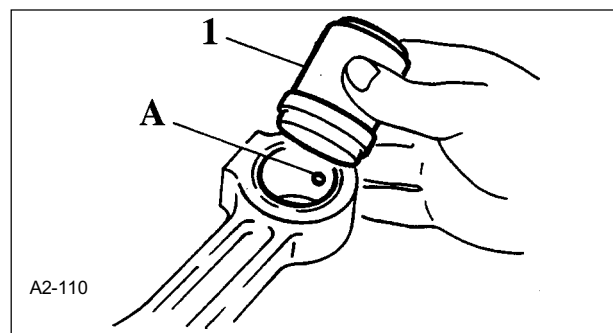
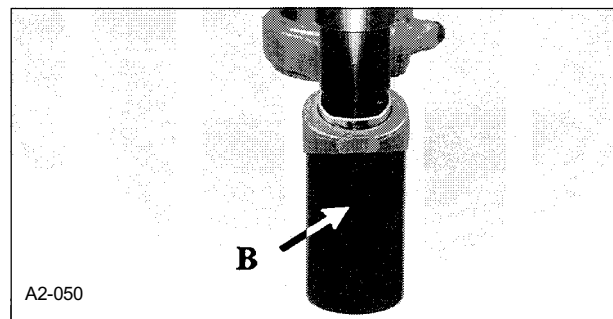
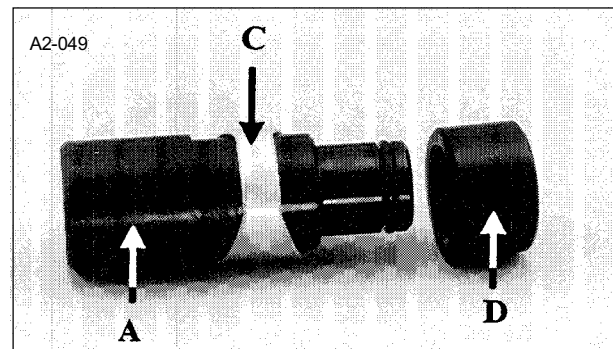
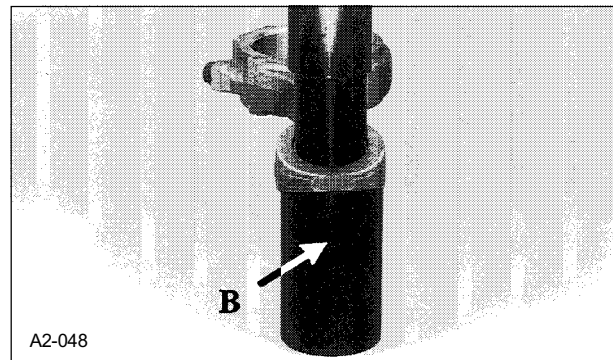
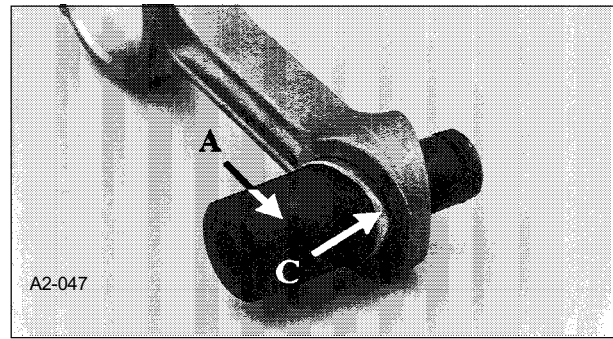

## Disassembly - Assembly

### • Checking the piston heads and skirts

Check that the pistons are not scratched and show no trace of seizing or overheating.

Measure the diameter of the piston at 19 mm from the bottom of the skirt, perpendicularly to the piston's pin. Compare the dimension measured with the initial dimension: 106.38 - 106.40 mm.

### • Compression ring groove

Use gauge No.5507 (TRT 51) or 5563 (- DRT 50/51 - TRT 50) to check the state of wear of the compression ring groove.

1 - Piston

a - Piston can be used

b - Piston to be changed

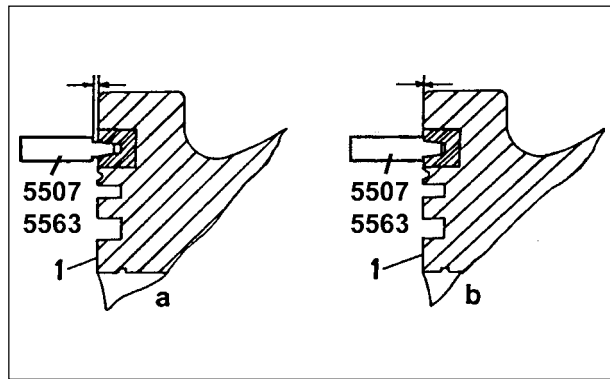

A2-051

### • Compression and oil ring grooves

Use a new ring and a set of shims to determine the clearance, which should not exceed 0.20 mm.

If the clearance exceeds this dimension, change the piston.

### • Fitting piston rings

Fit the piston rings using the ring extender No.8110. The "." stamped marks, one for the compression ring (No. 1) and two for the oil ring (No.2), must be directed towards the piston head.

**Note: The ring Nos.1 and 2 can also be identified using marks "Top", "T" or ".". During their installation, check that the rings are correctly positioned.**

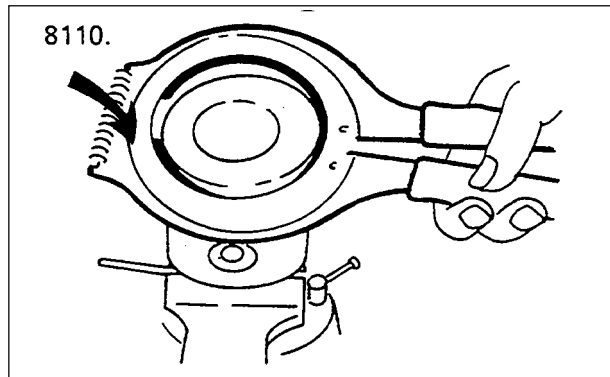

A2-052

### • Fitting the oil ring

Fit the oil ring (3) in the lower groove, on the expander. Check that the opening of the oil ring is opposite the opening on the expander.

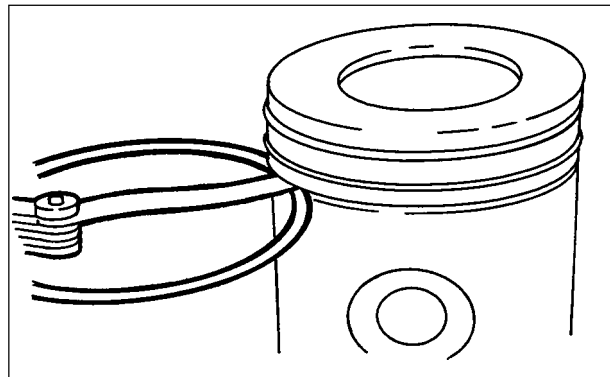

A2-053



A2-054

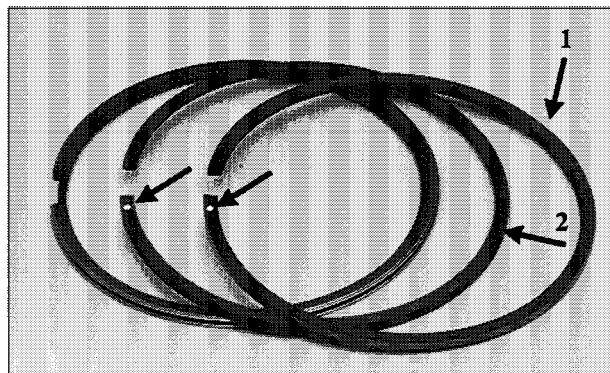

A2-055

## Disassembly - Assembly

### •Piston/connecting rods assembly

**Note: Reassemble the pistons on the connecting rods they were removed from.**

- 1 - Lubricate the piston pin and bush with clean engine oil.
- 2 - Assemble the pistons and connecting rods, while checking that the marks "FRONT" (front) (A) on the side or the upper face of the piston and on the same side of the connecting rod are located on the same side.

**IMPORTANT: If the mark "FRONT" is not visible on the side or the upper face of the piston, fit the piston on its connecting rod while ensuring that the combustion chamber offset on the piston is located on the side opposite the camshaft. The long side of the connecting rod must be fitted on the camshaft side.**

- 1 - Camshaft side
- 2 - Liner bore pin
- 3 - Combustion chamber offset

- 3 - Insert the piston pin (B) in the piston pin bore. Install new circlips (C) while directing the circlips cutting edge opposite the piston pin. Check that the circlips are properly pushed into the piston pin bore grooves.

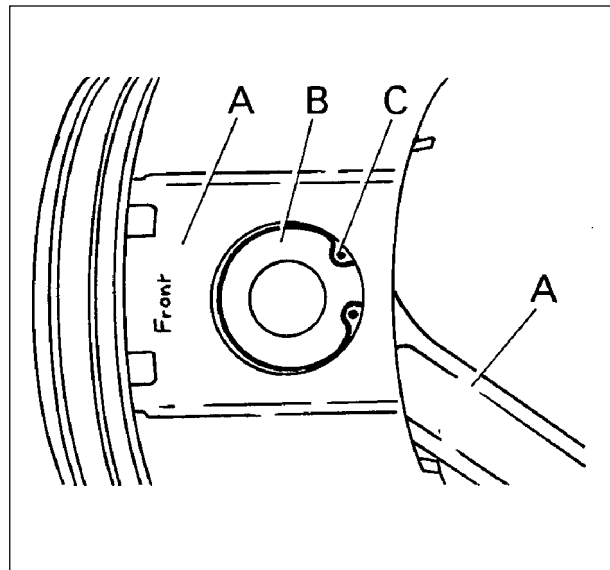

A2-056

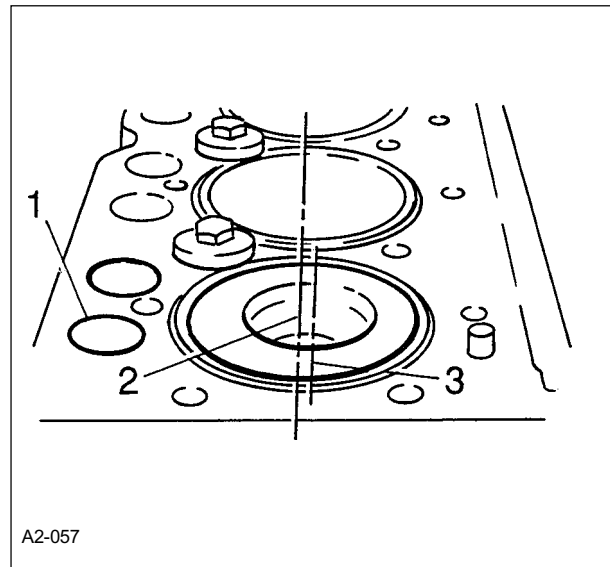

A2-057

### • Ring spacing

The figure here shows where the ring openings must be located.

- A - Piston head
- B - Compression ring opening
- C - Oil ring opening
- D - Expander opening
- E - Compression ring opening
- F - Slit in the expander
- G - Engine front

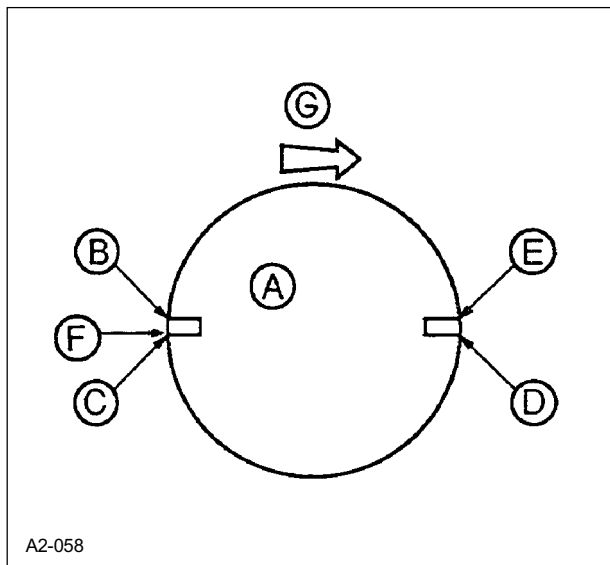

A2-058

## Disassembly - Assembly

### • Inspecting the connecting rod and the cap

- 1 - Inspect the connecting rods and the caps to ensure that they are neither worn, nor damaged; search for chips and scratches in the connecting zone (A).

**IMPORTANT:** Do not scratch the connecting surfaces of the connecting rod and cap. This is absolutely vital on Précision Joint™ connecting rods to guarantee correct coupling. Never rub these surfaces (C) with a metallic brush nor any other tool. The contact surfaces must be preserved.

- 2 - Inspect the cap bolt holes (B) and the adjacent surfaces. In the presence of any defect, change the connecting rod and the cap.

**IMPORTANT:** Never swap connecting rods and caps.

- A - Coupling zone
- B - Cap holes
- C - Précision Joint™ surfaces

### • Fitting the bearing in the cap

**Note:** Because of their manufacturing process, the Précision Joint™ connecting rod and caps both comprise a notch, whereas the carried over bearing has a single pin. Only one notch on the cap is used for the bearing's pin.

- 1 - Fit the carried over bearing in the connecting rod cap with the pin (A) in the notch (B).
- 2 - Apply clean engine oil to the carried over bearing. Fit the cap on the connecting rod with the pins on the same side.

- A - Pin
- B - Notch
- C - Additional notch (not used)

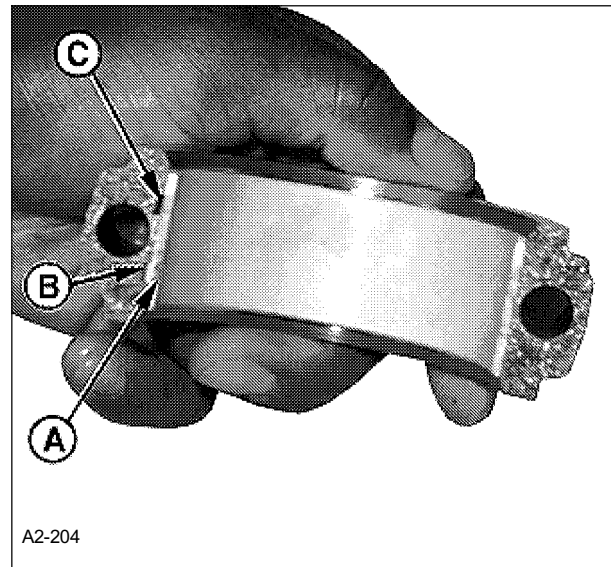
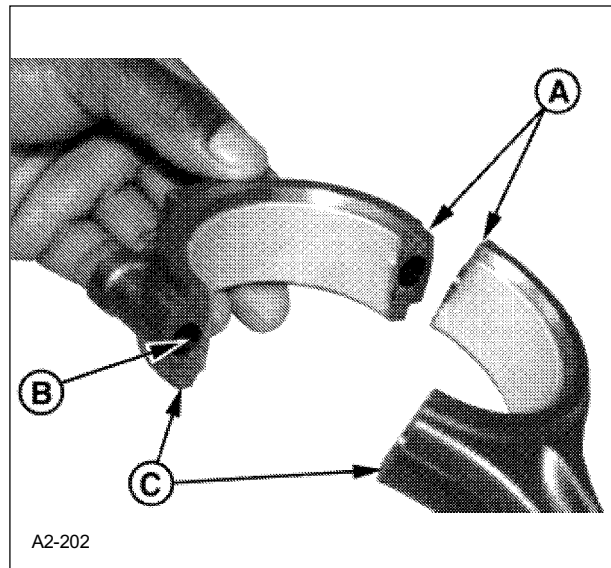

## Disassembly - Assembly

### • Reassembling pistons and connecting rods

**Note:** the pistons must be reassembled in the liners they were extracted from.

- 1 - Smear the pistons and rings with clean engine oil. Fit the pistons into the liners using the ring compressor No. 8111 (1).

**Note:** Check for each piston that the mark "FRONT" (A) on the upper face of the piston is turned towards the front of the cylinder block.

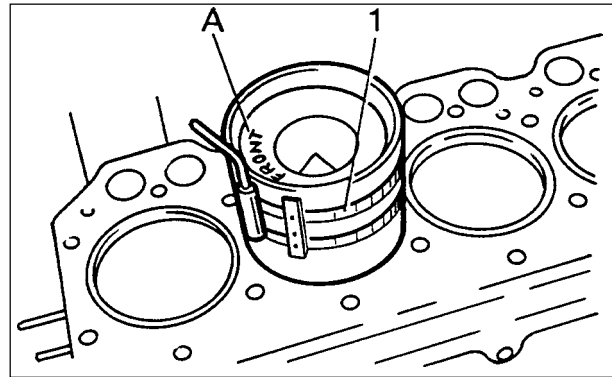

A2-059

- 2 - Push the piston into the liner until the upper ring is fully inside it.

### • Assembling the cap onto the connecting rod

- 1 - Smear the half-bearings with clean engine oil, then assemble the cap onto the connecting rod with the pins (A) on the same side. The notch (C) is not used.

**IMPORTANT:** Ensure that the cap is correctly aligned on the connecting rod with the junction surfaces perfectly coupled.



A2-204

- 2 - Dip the connecting rod bolts in clean engine oil and fit them.

**IMPORTANT:** Never use the connecting rod bolts more than once for the final assembly of the engine. When connecting rod bolts have been tightened at final torque, do not reuse them.

- 3 - Tighten the bolts alternatively at 5.8 daN.m, then turn each bolt at a 90-100 degree angle.

### • Tightening method

- 1 - Position the wrench in parallel the engine axis (A).
- 2 - Tighten the bolt until the wrench is perpendicular to the engine axis (B).

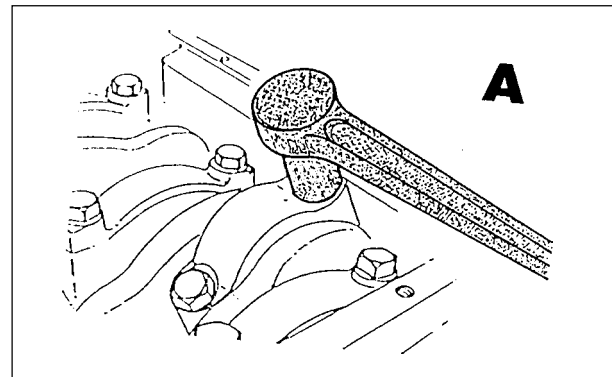

A2-061

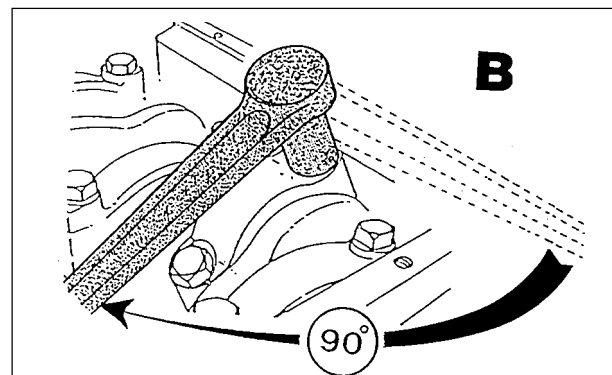

A2-062

## Disassembly - Assembly

### • Measuring piston overlap

Use the checking tool No.8180 (1).

- 1 - Calibrate the checking tool.
  - Fit the calibration rule on the base.
  - Calibrate the comparator to zero.
  - Remove the rule.
- 2 - Implementing the control tool
  - Position the checking tool on the cylinder to check.
- 3 - Measuring the piston overlap
  - Bring the piston to the top dead centre using the comparator and the engine displacement tool.
  - Read directly the piston overlap value in respect of the gasket face of the engine block.
  - Move the apparatus on the longitudinal axis of the engine, and record a second value.
  - Calculate the average over the 2 values.
- 4 - If the gauge No.8180 is used, the piston overlap must not exceed 0.20 mm.

**Note: If the gauge No.8180 is not available, use a comparator. In this case, the piston overlap must not exceed 0.35 mm.**

- 5 - If the overlap exceeds the dimensions specified, check all the parts involved to determine its cause.
  - 1 - Liner bore pin
  - 2 - Piston at TDC

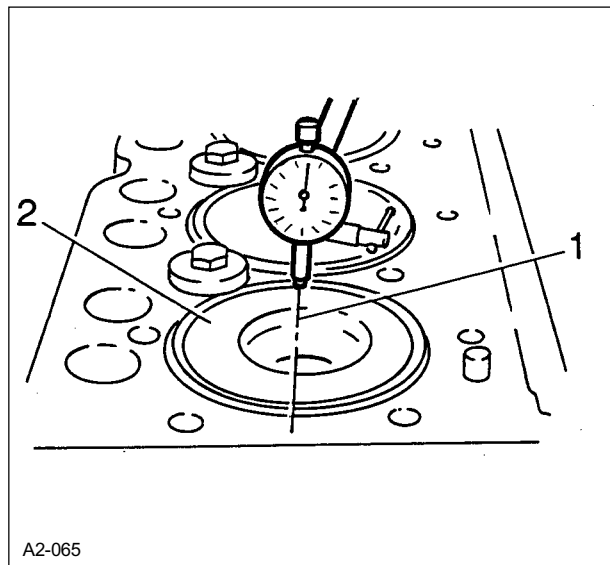
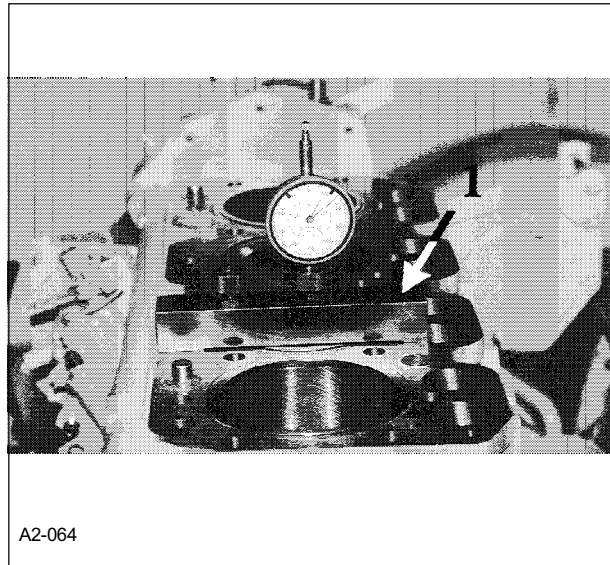
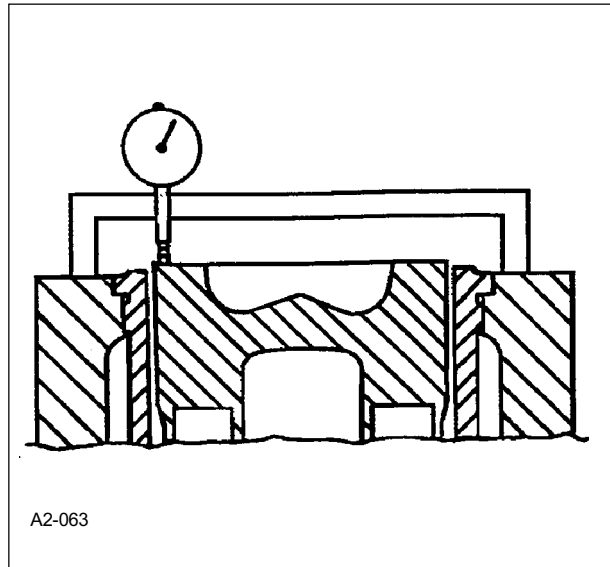



**Suggest:**

**If the above button click is invalid.**

**Please download this document**

**first, and then click the above link**

**to download the complete manual.**

**Thank you so much for reading**

## Disassembly - Assembly

### Crankshaft, bearings, and flywheel

#### • Fitting bearing bushes

1 - Install the bearing bushes. Check that the bearing bush tags (**A**) are engaged in the slots (**B**) in the cylinder block and the bearing seats. Also check that the bearing bush lubrication holes (**C**) are aligned with the oil passages in the block (**D**). During assembly, apply a thick layer of clean engine oil:

- on all cylinder block bearings,
- on both sides of the bearings,
- on the outside diameter of the journals.

2 - Fit the thrust bearing (**E**) in the rear bearing (**F**) of the cylinder block after dipping them in clean engine oil.

- A - Tags in the bearing bush
- B - Slot in the block
- C - Lubrication holes in the bearing bush
- D - Oil passages in the block
- E - Rear thrust bearing bush.

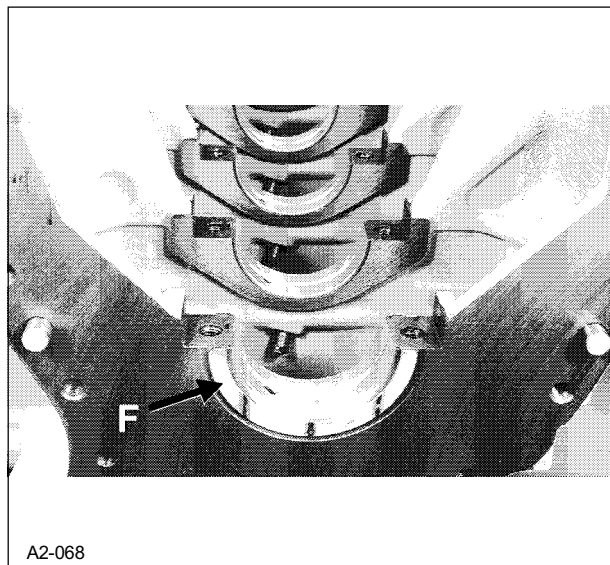
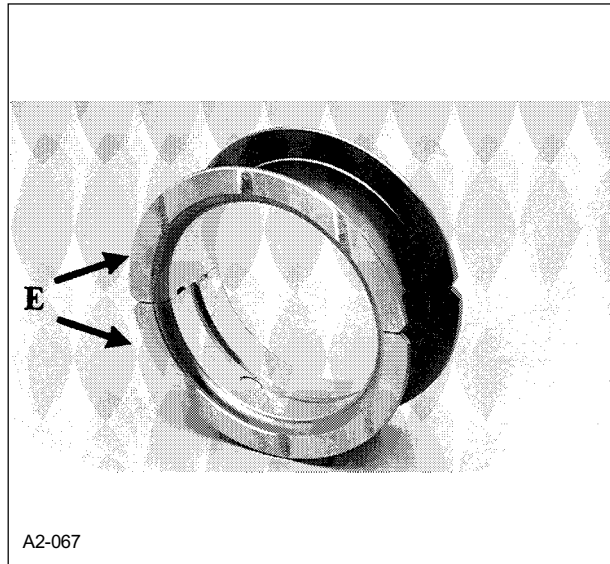
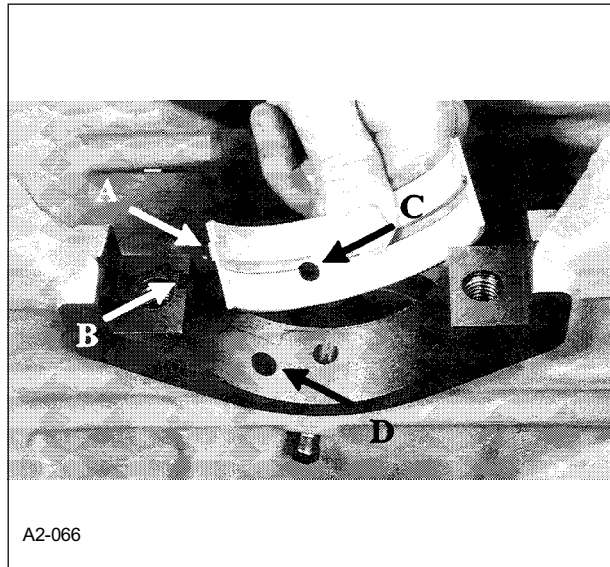

**<https://www.ebooklibonline.com>**

Hello dear friend!

Thank you very much for reading.

Enter the link into your browser.

The full manual is available for immediate download.

**<https://www.ebooklibonline.com>**