

**2355, 2555,
2755 and 2855N
Tractors**

**TECHNICAL
MANUAL**

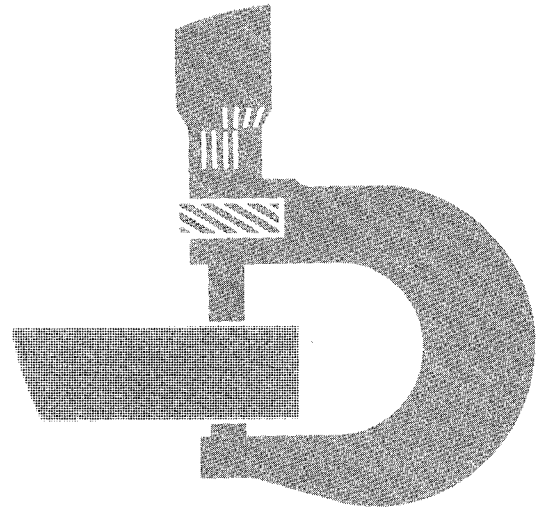

**John Deere Werke Mannheim
TM4434**

Litho in U.S.A. (Nov-89)

2355, 2555, 2755 AND 2855N TRACTORS TECHNICAL MANUAL TM4434 (NOV-89)

SECTION CONTENTS IN GROUPS – REPAIR

05 – SAFETY

10 – GENERAL

- 05 – Specifications
- 10 – Predelivery, delivery and after-sales inspections
- 15 – Lubrication and service
- 20 – Tune-up
- 25 – Tractor separation

20 – ENGINE

- 05 – Radiator, viscous fan drive and fan

30 – FUEL AND AIR INTAKE SYSTEM

- 05 – Fuel tank, auxiliary fuel tank and water trap
- 10 – Cold weather starting aids
- 15 – Speed control linkage
- 20 – Air cleaner

40 – ELECTRICAL SYSTEM

- 05 – Wiring harnesses
- 10 – Controls and instruments (without SOUND-GARD body)
- 15 – Controls and instruments (with SOUND-GARD body)
- 20 – Lighting system
- 25 – Starting motor
- 30 – Alternator

50 – POWER TRAIN

- 05 – Clutch operating systems
- 10 – Engine single-stage clutch (without Reverser)
- 15 – Engine single-stage clutch (with Reverser)
- 20 – Engine dual-stage clutch
- 25 – Hi-Lo shift unit
- 30 – Reverser
- 35 – Creeper transmission
- 40 – Transmission – console shift
- 45 – Transmission – center shift
- 50 – Synchronized transmission and transmission oil pump
- 55 – Collar-shift transmission and transmission oil pumps
- 60 – Differential
- 65 – Final drives
- 70 – Independent PTO shafts
- 75 – Continuous-running PTO's
- 80 – Front PTO
- 85 – Front wheel drive u.j. drive shaft and disk clutch

60 – STEERING SYSTEM AND BRAKES

- 05 – Hydrostatic steering
- 10 – Steering cylinder (without front wheel drive)
- 15 – Power steering
- 20 – Hydraulic brakes
- 25 – Handbrake

COPYRIGHT © 1989 DEERE & Co.
European Office Mannheim
All rights reserved
A John Deere ILLUSTRATION™ Manual
PREVIOUS EDITION
COPYRIGHT © 1987

INHALT-LB701AE-011088

SECTION CONTENTS IN GROUPS – REPAIR

70 – HYDRAULIC SYSTEM

- 05 – Valves
- 10 – Hydraulic pumps
- 15 – Rockshaft
- 25 – Selective control valves (spool type)
- 30 – Selective control valves (poppet valve type)
- 35 – ISO breakaway couplers
- 40 – ISO quick couplers
- 45 – Remote cylinder

80 – MISCELLANEOUS

- 05 – Front axle
- 10 – Front and rear wheels

90 – OPERATOR'S STATION

- 05 – Safe handling of refrigerants
- 06 – Servicing air conditioning system
- 07 – Compressor (up to tractor Serial No. 663 473L)
- 08 – Compressor (from tractor Serial No. 663 474L)
- 09 – Components of air conditioning system
- 10 – Cab ventilation and heating
- 15 – Operator's seats
- 20 – SOUND-GARD Body
- 25 – 2-post roll guard
- 30 – 2-post telescopic roll guard

INHALT-LB702AE-011088

<https://www.ebooklibonline.com>

Hello dear friend!

Thank you very much for reading.

Enter the link into your browser.

The full manual is available for immediate download.

<https://www.ebooklibonline.com>

SPECIFICATIONS

SERIAL NUMBER PLATES

The following illustrations show the serial number plates for tractor major components. The letters and figures on these plates are required for warranty claims and when ordering replacement parts.

TECHDA-LA71005AE-180385

PRODUCT IDENTIFICATION NUMBER PLATE

The product identification number plate is located on right-hand side of front axle carrier.
The chassis number is stamped in front axle carrier next to the identification number plate.

NOTE: When ordering tractor parts (excluding engine parts), quote all letters and figures of serial number stamped on this plate.

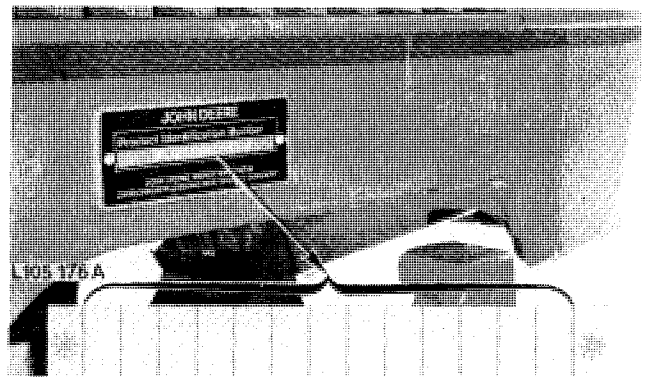

L105176A-LB71005AE-011088

ENGINE SERIAL NUMBER PLATE

The engine serial number plate is located on right-hand side of engine block.

NOTE: The engine serial number plate shows the engine type as well as the engine serial number. When ordering engine parts, quote all figures stamped on this plate.

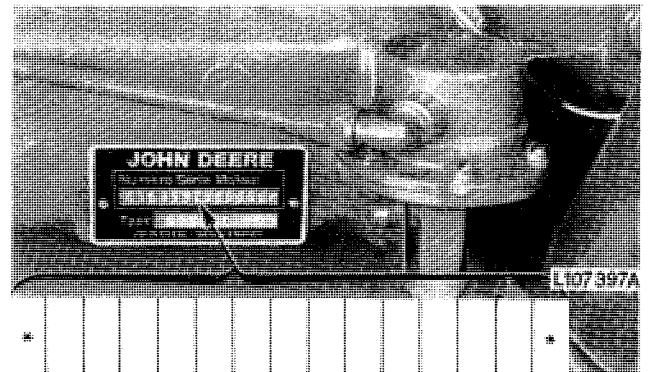

L107397A-LB41005AE-010687

**TRANSMISSION SERIAL NUMBER PLATE
(Tractors Without SOUND-GARD® Body)**

The transmission serial number plate is located on right-hand side of transmission case.

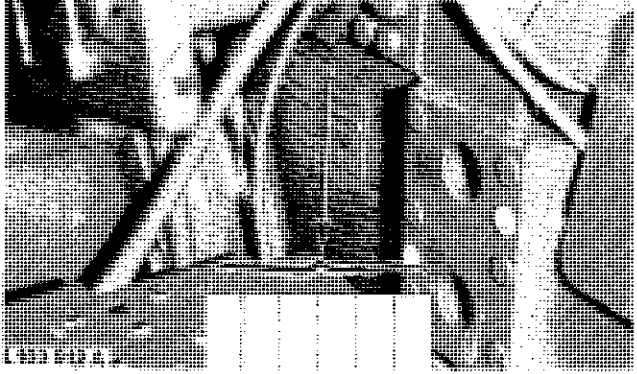

From Tractor Serial No. 617 678L, an additional serial number plate is attached to left-hand side of dash.

NOTE: In addition to the transmission serial number and transmission type, this serial number plate also specifies differential and front wheel drive gear ratios.

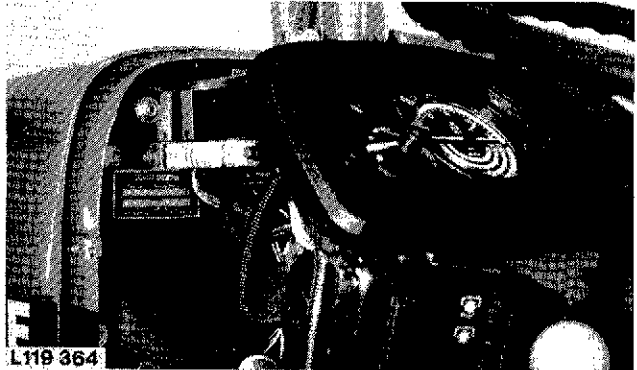

L103912A, L119364-LB71005AE-011088

**TRANSMISSION SERIAL NUMBER PLATE
(Tractors With SOUND-GARD Body)**

The transmission serial number plate is located on right-hand crossmember of SOUND-GARD body and on right-hand side of transmission case.

NOTE: In addition to serial number of transmission and transmission type, this serial number plate also specifies differential and front wheel drive gear ratios.

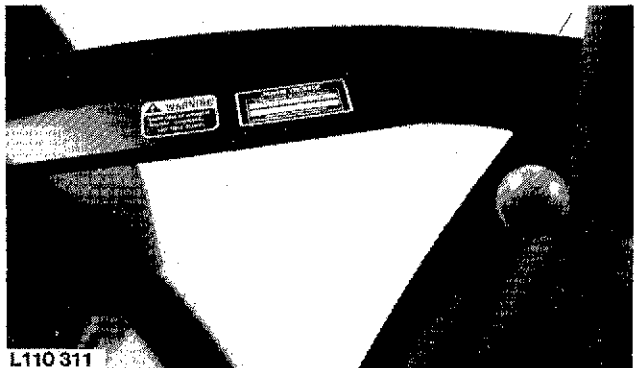

L110311-LA91005AE-000386

**FRONT WHEEL DRIVE AXLE SERIAL
NUMBER PLATE**

The front wheel drive axle serial number plate is located on rear of right-hand axle half.

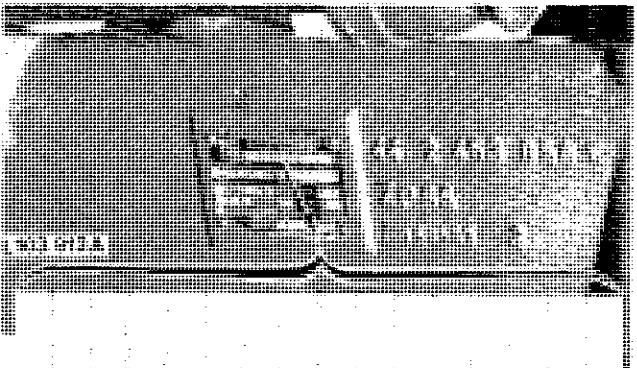

L103913A-LA71005AE-000385

Specifications

SOUND-GARD BODY SERIAL NUMBER

With operator's cab door open, cab serial number plate is visible in roof recess as you enter the cab.

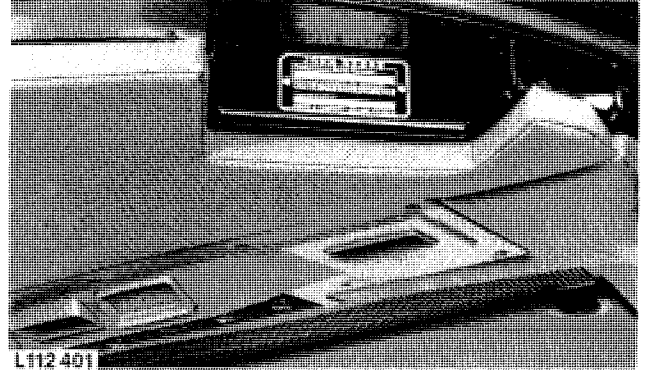

L112 401

L112401-LA91005AE-051185

MODEL SERIAL NUMBERS

Fuel injection pump, fuel injection nozzles, alternator, starting motor, hydrostatic steering valve, air conditioning system compressor (when equipped) and hydraulic pump have serial numbers to facilitate identification of different makes of a given unit.

TECHDA-LA71005BE-180385

Specifications

ENGINE

Number of cylinders	4
Cylinder liner bore	106.5 mm (4.19 in.)
Stroke	110 mm (4.33 in.)
Displacement	3920 cm ³ (239 cu.in.)
Compression ratio	17.8 : 1
Max. torque	
With synchronized transmission	
– 2355 at 1400 rpm	255 Nm (188 ft-lb)
– 2555 at 1500 rpm	285 Nm (210 ft-lb)
– 2755 at 1500 rpm	328 Nm (241 ft-lb)
– 2855N at 1500 rpm	340 Nm (250 ft-lb)
With collar shift transmission	
– 2355 at 1300 rpm	230 Nm (169 ft-lb)
– 2555 at 1300 rpm	248 Nm (183 ft-lb)
– 2755 at 1500 rpm	297 Nm (219 ft-lb)
Firing order	1–3–4–2
Valve clearance (engine hot or cold)	
– Intake valve	0.35 mm (0.014 in.)
– Exhaust valve	0.45 mm (0.018 in.)
Slow idle speed	750 to 850 rpm
Fast idle speed	
– Synchronized transmission	2410 to 2510 rpm
– Collar shift transmission	2610 to 2660 rpm
Rated engine speed	
– Synchronized transmission	2300 rpm
– Collar shift transmission	2500 rpm
Working speed range	
Synchronized transmission	
– 2355	1400 to 2300 rpm
– 2555, 2755 and 2855N	1500 to 2300 rpm
Collar shift transmission	
– 2355 and 2555	1300 to 2500 rpm
– 2755	1500 to 2500 rpm

TECHDA-LB71005AE-010487

Specifications

Engine speed for PTO operation

Synchronized transmission

- 540 rpm PTO 2070 rpm
- 1000 rpm PTO 2172 rpm

Collar shift transmission

- 540 rpm PTO 2075 rpm

PTO horsepower at engine rated speed

- According to SAE J 1349

	Tractors with:	
	Synchronized Transmission	Collar Shift Transmission
- 2355	41 kW (55 hp)	41 kW (55 hp)
- 2555	48 kW (65 hp)	48 kW (65 hp)
- 2755	56 kW (75 hp)	56 kW (75 hp)
- 2855N	60 kW (80 hp)	

Lubrication system Full internal force feed system with full flow filter

ENGINE CLUTCH

- Type Single dry disk clutch with torsion damper or dual dry disk clutch, foot-operated

COOLING SYSTEM

- Type Pressurized system with centrifugal pump
 - Temperature regulation Thermostat and, when equipped, viscous fan drive

FUEL SYSTEM

- Type Direct injection
 - Fuel injection pump timing to engine TDC
 - Fuel injection pump type Distributor type with two or four pistons
 - Air cleaner Dry-type air cleaner with secondary (safety) element

* With engine run in (over 100 hours of operation) and at operating temperature (engine and transmission), measured by means of a dynamometer. Permissible variation $\pm 5\%$

TECHDA-LB71005AE-011088

Specifications

ELECTRICAL SYSTEM

- Batteries 2 x 12 volts, 55 Ah or 66 Ah
- Alternator with external regulator 14 volts, 55 or 85 amps.
- Starting motor 12 volts, 2.7 kW (3.7 hp)
- Battery terminal grounded negative

SYNCHRONIZED TRANSMISSION

- Type Synchronized transmission
- Gear selections 8 forward and 4 reverse
- Gear shifting Two forward ranges and one reverse range;
Synchronized forward and reverse shifting
within range

COLLAR SHIFT TRANSMISSION

- Type Helical gears
- Gear selections 8 forward and 4 reverse
- Gear shifting Two forward ranges and one reverse range

HI-LO SHIFT UNIT

- Type Hydraulic gear reduction unit which can be
shifted under load with "wet" multiple disk
clutch and brake packs.
- Travel speed decreases in each gear by Approx. 20 %
- Shifting to normal (Hi) speed Hydraulic
- Shifting to reduced (Lo) speed Preloaded Belleville springs

REVERSER TRANSMISSION

- Type Hydraulic gear reduction unit which can be
shifted under load with "wet" multiple disk
clutch and brake packs, planetary reverser unit.
- Gear selections 1 to 4
- Increase in reverse gear speeds Approx. 16 %

CREEPER TRANSMISSION

- Type Synchronized reduction gear
- Travel speed decrease in low (l) and reverse
ranges by Approx. 79%
- Shifting in both ranges Mechanically, not under load

TECHDA-LB71005CE-010487

Specifications

FRONT PTO

- Type	Independent of transmission, can be engaged and disengaged under load
- Control	Electric/hydraulic solenoid switch
- PTO speed at an engine speed of: 2172 rpm (counterclockwise)	1000 rpm
- PTO clutch	Hydraulically operated "wet" disk clutch
- PTO brake	Hydraulically operated "wet" disk brake

FRONT WHEEL DRIVE

- Type	Engaged hydraulically under load with "wet" disk clutch
- Control	Electric/hydraulic solenoid switch
- Drive engagement	Preloaded Belleville springs
- Drive disengagement	Hydraulic

HYDROSTATIC STEERING

- Type	Without mechanical linkage between steering valve and front wheels
--------------	--

POWER STEERING

- Type	Hydraulically operated steering linkage
--------------	---

FOOT BRAKES

- Rear wheel brakes	Self-adjusting, hydraulically operated "wet" disk brakes
---------------------------	--

HANDBRAKE

- Type	Mechanically operated band-type locking brake acting on the differential
--------------	--

HYDRAULIC SYSTEM

- Type	Closed, constant pressure system
- System pressure when pump pistons idle	16000 kPa (160 bar; 2320 psi)
- Operating pressure	14000 kPa (140 bar; 2050 psi)
- Hydraulic pump	8-piston pump with variable displacement

TECHDA-LB71005EE-010487

Specifications

ROCKSHAFT

- Type	With three-point hitch
- Regulation	Load control, depth control, load-and-depth control, float position
- Control	Via draft links

GROUND TRAVEL SPEEDS See Operator's Manual

FRONT AND REAR WHEELS

- Tires, tread widths, tire pressures and ballast weights	See Operator's Manual
--	-----------------------

DIMENSIONS AND WEIGHTS See Operator's Manual

CAPACITIES

Fuel tank	84.0 liters (22.2 U.S. gal.)
Auxiliary tank	52.0 liters (13.7 U.S. gal.)

Cooling system

- Without SOUND-GARD Body	13.0 liters (3.4 U.S. gal.)
- With SOUND-GARD Body	15.0 liters (4.0 U.S. gal.)

Engine crankcase

- Initial filling	10.5 liters (2.8 U.S. gal.)
- Crankcase with filter replacement	10.0 liters (2.6 U.S. gal.)

Transmission/hydraulic system (including oil reservoir and oil cooler)

- Initial filling (synchronized transmission)	
- Without front wheel drive	50.0 liters (13.2 U.S. gal.)
- With front wheel drive	53.0 liters (14.0 U.S. gal.)
- With front PTO	55.0 liters (14.5 U.S. gal.)

- Oil change with filter replacement

- Without front wheel drive	47.5 liters (12.5 U.S. gal.)
- With front wheel drive	50.5 liters (13.3 U.S. gal.)
- With front PTO	52.5 liters (13.9 U.S. gal.)

TECHDA-LB7:005BE-011088

Specifications

CAPACITIES (Contd.)

– Initial filling (collar shift transmission)	
with Reverser	36.0 liters (9.5 U.S.gal.)
without Reverser	
– 2355 and 2555*	41.0 liters (10.8 U.S. gal.)
– 2755	46.0 liters (12.2 U.S. gal.)
– Oil change with filter replacement	
with Reverser	28.0 liters (7.4 U.S.gal.)
without Reverser	
– 2355 and 2555*	33.0 liters (8.7 U.S. gal.)
– 2755	38.0 liters (10.0 U.S. gal.)
*With heavy-duty final drives, an additional	5.0 liters (1.3 U.S. gal.)
 Front wheel drive	
– Front axle housing	
– 2355 to 2755	5.3 liters (1.4 U.S. gal.)
– 2855N	3.25 liters (0.86 U.S. gal.)
– Wheel hub housing, each	0.75 liters (0.2 U.S. gal.)
 Hydraulically operated clutch system	250 cm ³ (8.75 fl.oz.)
 Air conditioning system	1.8 kg (4 lb)

TECHDA-LB71005CE-011088

PREDELIVERY INSPECTION

NOTE: Should a malfunction occur when carrying out the predelivery inspection, then see relevant T.M. "Engines" or "Operation and Tests".

INSPEK-LB21010JE-010488

CHECKING FUEL LINES FOR LEAKS

A—Tractors with auxiliary fuel tank
B—Tractors without auxiliary fuel tank

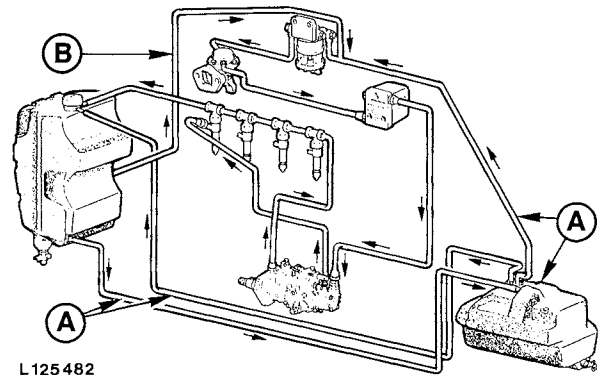

L125482

L125482-LB31010AE-010888

EXAMINING ENGINE FOR LEAKS

INSPEK-LB21010EE-010886

CHECKING OIL LEVEL IN ENGINE CRANKCASE

If necessary, add oil to bring oil level to top mark on dipstick. Use JOHN DEERE Torq-Gard Supreme engine oil SAE 10W-20 or an equivalent oil (see Group 15).

A—Oil dipstick
B—Oil filler neck

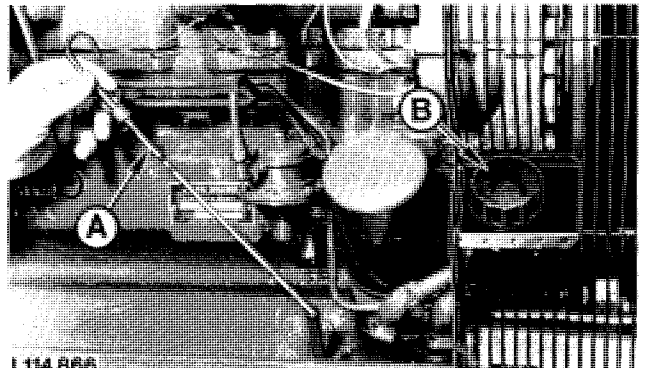

L114866

L114866-LB21010AE-010886

CHECKING COOLANT LEVEL

Tractors Without Expansion Tank

Coolant must reach up to marker plate in radiator.

On All Tractors

The cooling system is filled with JOHN DEERE engine coolant at the factory. It protects the engine against corrosion and against frost down to -36°C (-35°F).

IMPORTANT: Use only JOHN DEERE engine coolant in the cooling system, independent of the season.

If JOHN DEERE engine coolant is not available, use a mixture of 50% ethylene-glycol antifreeze/corrosion inhibitor and 50% clear, soft water. This guarantees engine protection against corrosion and frost down to -36°C (-35°F).

Never use any cooling system sealing additives.

Tractors With Expansion Tank

Coolant level should never drop below "MIN" mark.

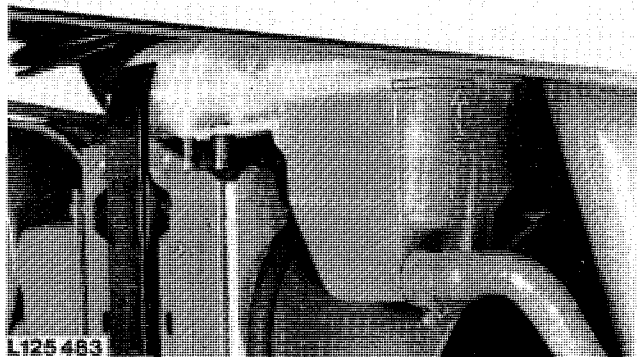
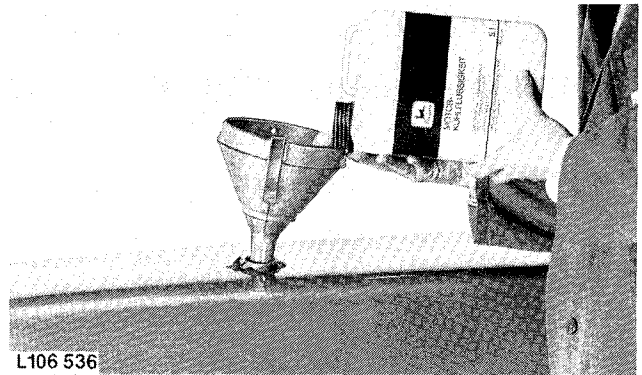
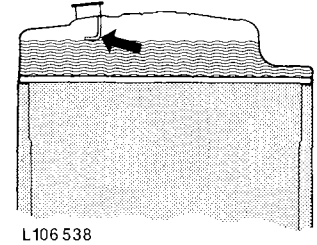
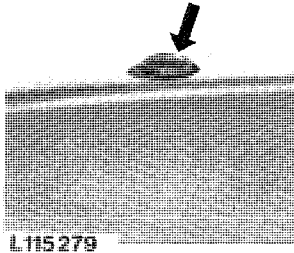

L115279,L106538,L106536,L125483-LB31010AE-010888

CHECKING ENGINE IDLE SPEEDS

Tractors with Synchronized Transmission

Warm up engine to operating temperature and check speeds.

Slow idle speed: 750 to 850 rpm

Fast idle speed: 2410 to 2510 rpm

See Section 30, Group 15, for adjustment.

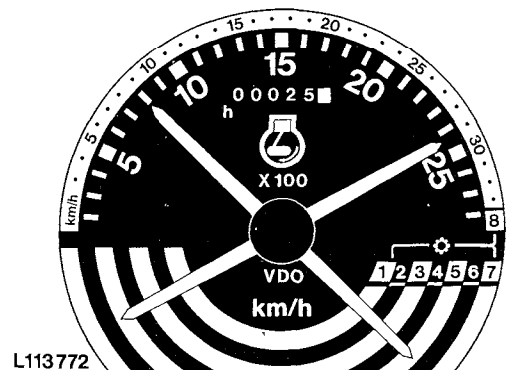

L113772-LB31010AE-010287

Tractors with Collar Shift Transmission

Warm up engine to operating temperature and check speeds.

Slow idle speed: 750 to 850 rpm
Fast idle speed: 2610 to 2660 rpm

See Section 30, Group 15, for adjustment.

L113 444

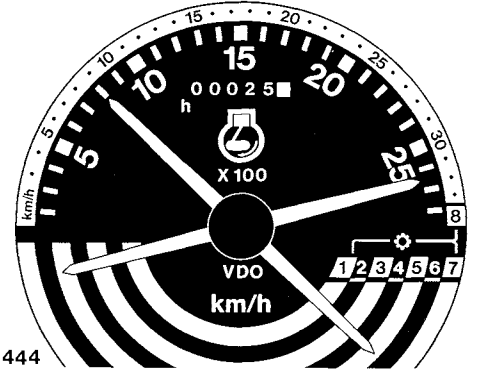

L113444-LB31010AE-010287

CHECKING FUNCTION OF ENGINE SHUT-OFF CABLE

Move hand throttle lever to idle position and run engine for 1 to 2 minutes at slow idle speed.

Completely pull out shut-off knob (A), making sure that engine stops immediately. Switch off main switch (B).

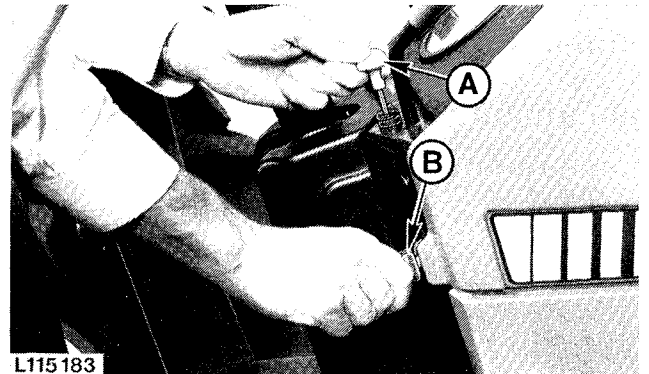

L115 183

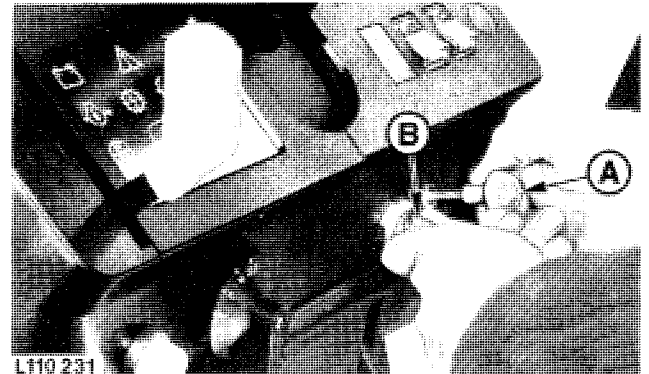

L110 231

L115183,L110231-LB71010AE-010487

CHECKING AIR CLEANER AND SAFETY ELEMENTS FOR CORRECT INSTALLATION

Make sure that dust unloading valve (C) (rubber cap) is installed on air cleaner.

- A-Air cleaner element
- B-Safety element
- C-Dust unloading valve

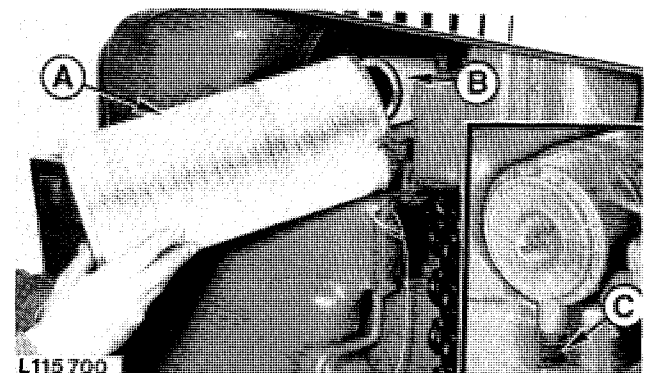

L115 700

L115700-LB61010AE-011086

CHECKING HOSE CLAMPS OF AIR INTAKE SYSTEM FOR TIGHTNESS

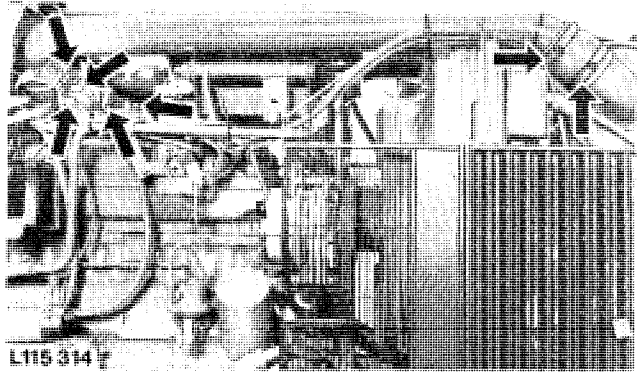

L115 314

L115314-LB71010AE-010487

INSTALLING EXHAUST STACK

Up To Tractor Serial No. 629 372L

Install weather flap with flap hinge at the rear (as seen in direction of forward travel).

Distance (A) between cap and stack end must be 2 mm (5/64 in.).

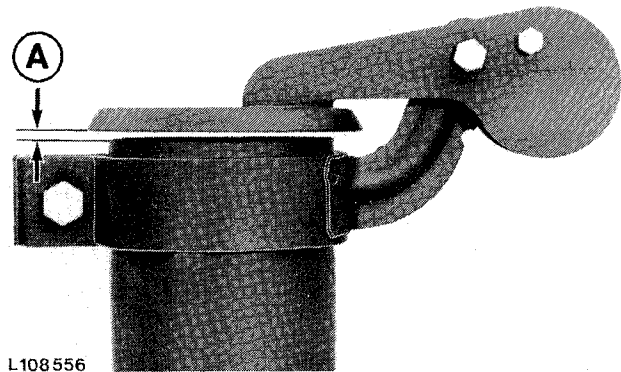

L108 556

L108556-LB21010AE-010488

From Tractor Serial No. 629 373L

Tractors with SOUND-GARD Body: Install exhaust stack with opening facing to the rear.

Tractors without SOUND-GARD Body: Install exhaust stack with opening facing to the left.

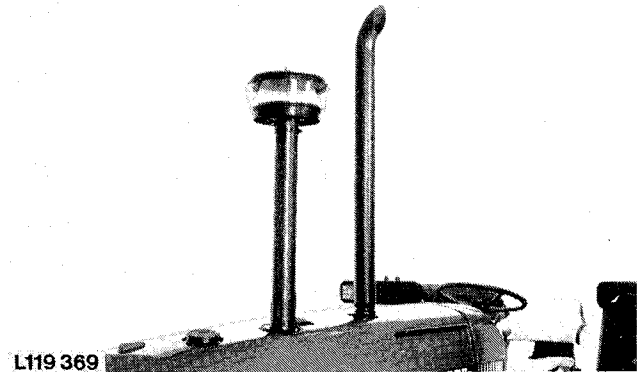

L119 369

L119369-LB61010AE-010688

CHECKING FAN BELT TENSION

Using belt tension gauge JDST-28 (C) check tension of fan belt.

Fan belt should have 19 mm (3/4 in.) flex with 90 N (20 lb) pull midway between crankshaft and alternator or water pump.

A-Fan belt
B-Attaching nut
C-Belt tension gauge (JDST-28)

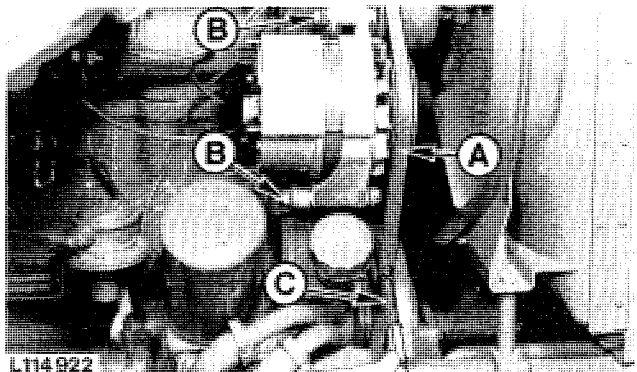

L114 922

L114922-LB21010AE-010886

CHECKING COMPRESSOR BELT TENSION (Tractors With Air Conditioning System)

Using belt tension gauge JDST-28 (A) check compressor belt tension.

Compressor belt should have 19 mm (3/4 in.) flex with 60 N (13 lb) pull midway between both pulleys.

A—Belt tension gauge
(JDST-28)

B—Adjusting screw
C—Compressor belt

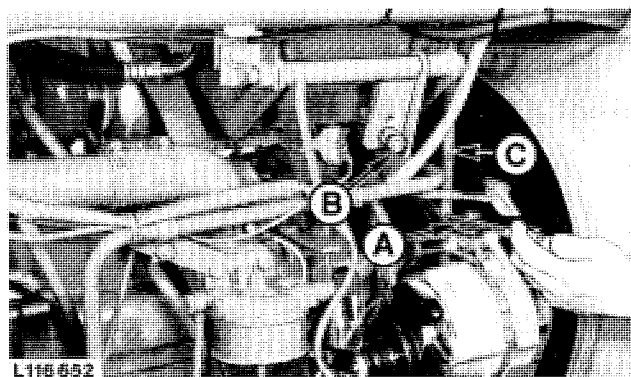

L116652-LB71020AE-010487

IMPORTANT NOTES

If a booster battery is to be used for charging and the tractor run for a short time without battery, do not, under any circumstances, interrupt the circuit by switching off the main switch before stopping the engine by means of the fuel pump shut-off cable. It is further recommended that additional loads (lights) be switched on while the engine is running. Do not run engine at speeds above 1000 rpm. Insulate battery end of disconnected starter cable properly to avoid damage to alternator and regulator.

Do not connect ground strap of booster battery to the SOUND-GARD Body.

Connect batteries or battery charger with the proper polarity (“+” and “-“). Incorrectly connected batteries will result in the immediate destruction of the rectifier diodes.

A—Positive terminals
B—Negative terminals

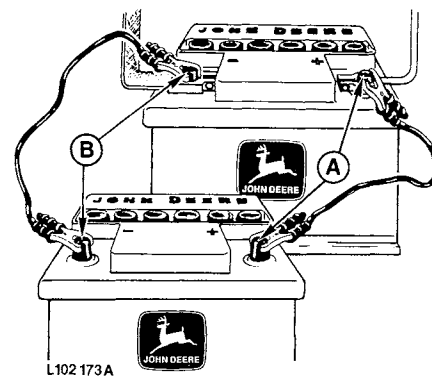

L102173A-LB71010AE-010487

CHECKING BATTERIES

Check battery terminals and cable ends and, if necessary, clean and coat them with petroleum jelly.

Check electrolyte level in each battery cell. If necessary, add distilled water to bring level above cell plates.

A-Filler caps

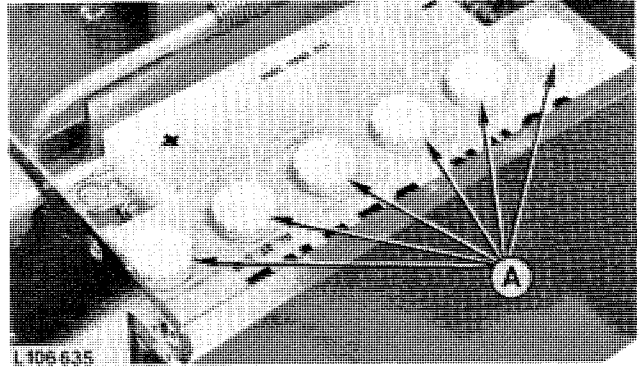

L106635

L106635-LA71010AE-091184

CHECKING NEUTRAL START SYSTEM

Depress clutch pedal (A).
 Move gear shift lever (B) to neutral position.
 Move range shift lever (C) to any range position.
 Pull out engine shut-off knob (D).
 Turn main switch (E) to start position.
 Starter should NOT crank.

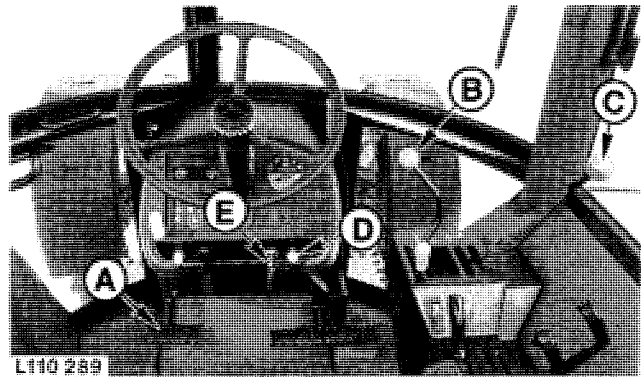

L110 289

A-Clutch pedal
 B-Gear shift lever
 C-Range shift lever
 D-Engine shut-off knob
 E-Main switch

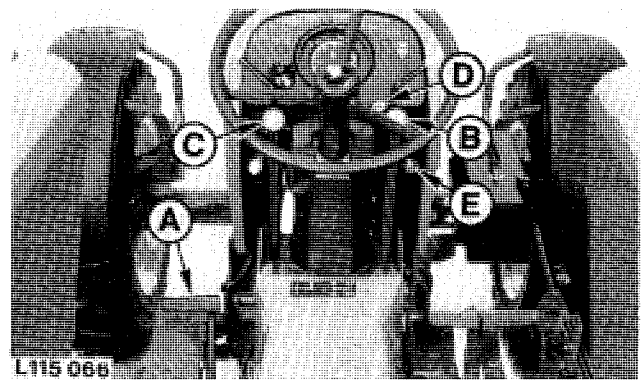

L115 066

L110289,L115066-LB71010AE-010487

CHECKING LIGHTING SYSTEM

See Operator's Manual.

Check adjustment of headlights and adjust, when necessary.

A-Light switch
 B-Dimmer switch

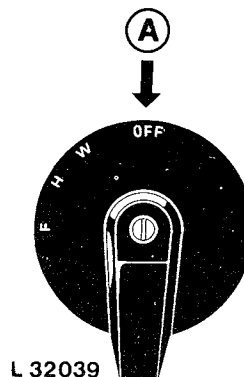

L 32039

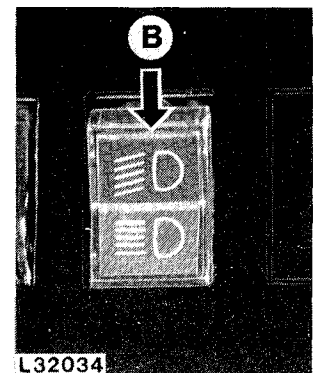

L32034

L32039,L32034-LB61010AE-011086

CHECKING FAN SWITCH (With SOUND-GARD Body)

Open air louvers (B).

Check function of three-stage cab ventilation and heater fan switch (A).

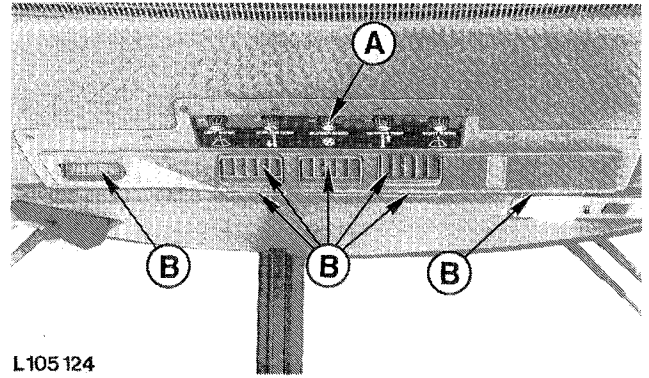

L105 124

L105124-LB61010AE-011086

CHECKING HEATER CONTROL SWITCH (With SOUND-GARD Body)

With engine running at operating temperature, turn control switch to the right and wait until warm air enters cab through the air louvers.

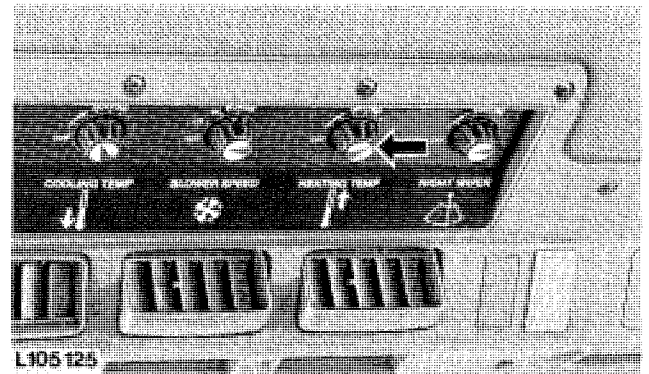

L105 125

L105125-LB61010AE-011086

CHECKING THERMOSTAT SWITCH (Tractors With Air Conditioning System)

With fan switched on, turn infinitely adjustable switch to the right and wait until cool air enters cab through the air louvers.

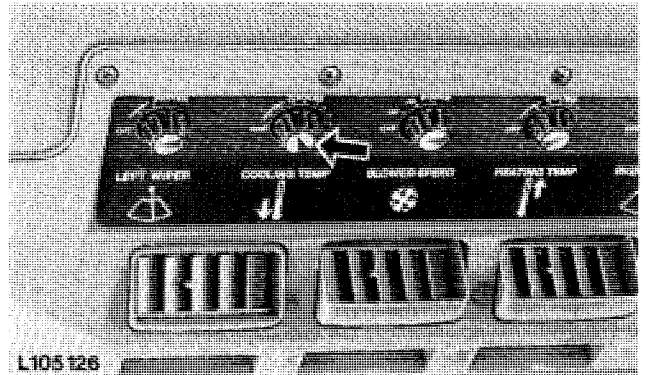

L105 126

L105126-LB61010AE-011086

CHECKING WINDSHIELD WASHER SYSTEM (With SOUND-GARD Body)

Operate tumbler switch (A) of washer system.

Add a suitable commercially available anti-freeze solution to reservoir (B) if temperature is likely to drop below freezing point.

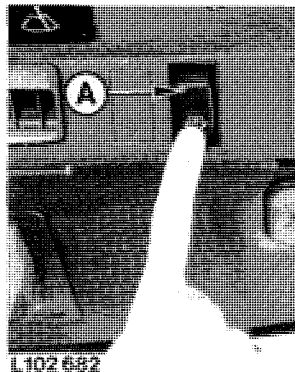

L102 682

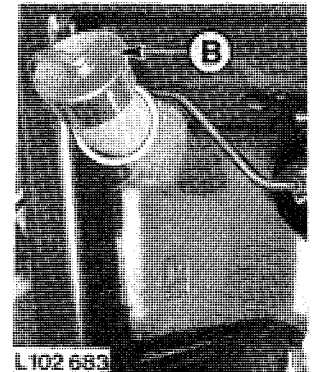

L102 683

L102682,L102683-LB61010AE-011086

CHECKING FUNCTION OF WINDSHIELD WIPERS (With SOUND-GARD Body)

Check both windshield wiper speeds by turning both two-speed switches.



L102684-LB61010AE-011086

CHECKING CAB INTERIOR LIGHTS (With SOUND-GARD Body)

Turn switch (B) to position 1, lamp (A) glows continuously and, in position 2, it glows as long as cab door is open.

Lamp (C) illuminates transmission shift lever as soon as headlights are switched on.

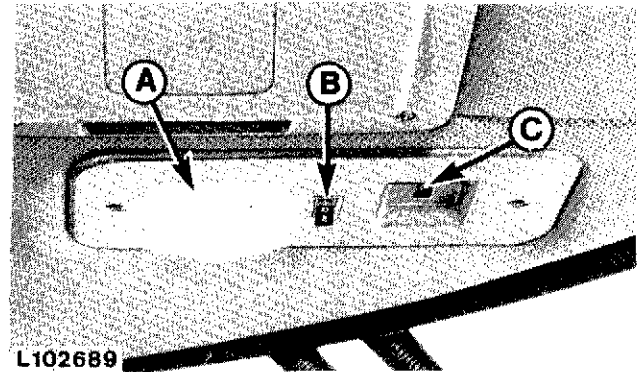

L102689-LB61010AE-011086

CHECKING INSTRUMENTS AND INDICATOR LIGHTS

See Operator's Manual.

INSPEK-LB21010FE-010886



Suggest:

If the above button click is invalid.

Please download this document

first, and then click the above link

to download the complete manual.

Thank you so much for reading

CHECKING TRANSMISSION/HYDRAULIC SYSTEM OIL LEVEL

IMPORTANT: Check oil level. Check prior to starting engine after long shut-down period when oil is cold.

Park tractor on level ground. Completely lower rock-shaft. Remove dipstick (A) and wipe clean. Reinsert dipstick, again remove and check oil level.

NOTE: If oil level is below top mark, top up with oil to bring level up to top mark on dipstick through filler neck (B).

IMPORTANT: After having topped up transmission with oil, wait for a period of five minutes before rechecking oil level with dipstick.

If necessary, add JOHN DEERE HY-GARD® Transmission and Hydraulic Oil or equivalent (see Group 15) to bring oil level to top mark on dipstick.

NOTE: Types of oil not meeting JOHN DEERE specifications will not give satisfactory service and may result in eventual damage.

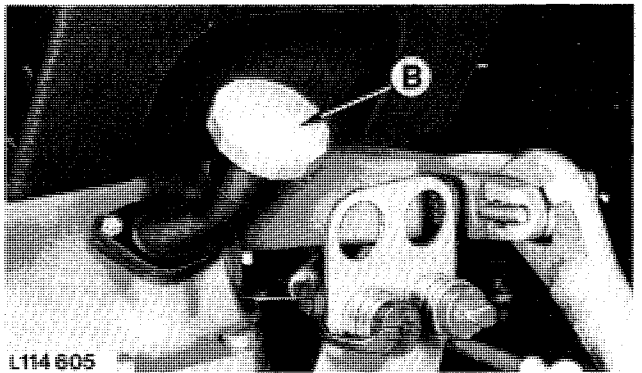
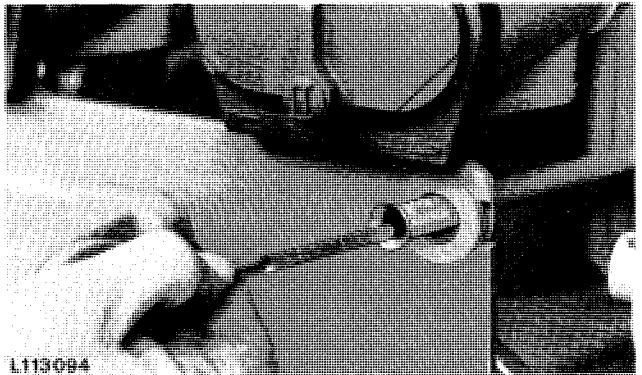
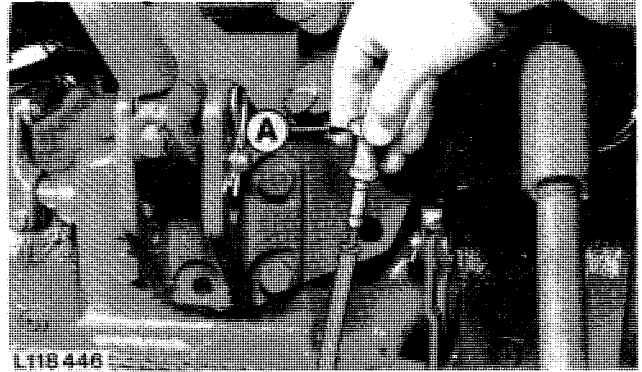

L118446,L113094,L114605-LB71010AE-011088

CHECKING LEVEL OF BRAKE FLUID (With Hydraulically Operated Clutch)

Level of fluid should be between the marks "MIN" and "MAX". When necessary add brake fluid type FMVSS 116 DOT 4.

A-Reservoir

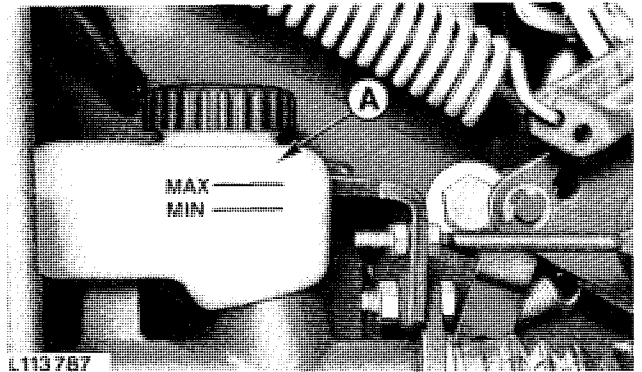

L113787-LB61010AE-000688

<https://www.ebooklibonline.com>

Hello dear friend!

Thank you very much for reading.

Enter the link into your browser.

The full manual is available for immediate download.

<https://www.ebooklibonline.com>