



2040 and 2240 Tractor



JOHN DEERE

TECHNICAL MANUAL 2040 and 2240 Tractor

TM1221 (01NOV80) English

John Deere Tractor Works
TM1221 (01NOV80)

LITHO IN U.S.A.
ENGLISH



2040 and 2240 Tractors (Serial No. 350,000L-)

Technical Manual
TM-1221 (Nov-80)

CONTENTS

SECTION 10 — GENERAL

- Group 00 — Specifications and Special Tools
- Group 05 — Pre-delivery, Delivery and After-Sales Inspections
- Group 10 — Lubrication and Periodic Service
- Group 15 — Engine and Tractor Tune-Up
- Group 20 — Tractor Separation

SECTION 20 — ENGINE

- Group 00 — Specifications and Special Tools
- Group 05 — General Information, Diagnosing Malfunctions
- Group 10 — Cylinder Head and Camshaft
- Group 15 — Cylinder Block, Liners, Pistons and Connecting Rods
- Group 20 — Crankshaft, Main Bearings and Flywheel
- Group 25 — Timing Gear Train
- Group 30 — Engine Lubrication System
- Group 35 — Engine Cooling System

SECTION 30 — FUEL SYSTEM

- Group 00 — Specifications and Special Tools
- Group 05 — Diagnosing Malfunctions
- Group 10 — Fuel Tank, Fuel Transfer Pump and Fuel Filter
- Group 15 — Roto Diesel Fuel Injection Pump
- Group 20 — Fuel Injection Nozzles
- Group 25 — Ether Starting Aid
- Group 30 — Speed Control Linkage
- Group 35 — Air Intake System

SECTION 40 — ELECTRICAL SYSTEM

- Group 00 — Specifications and Special Tools
- Group 05 — Description and Diagnosing Malfunctions
- Group 10 — Wiring Harnesses
- Group 15 — Controls and Instruments
- Group 20 — Lighting Systems
- Group 25 — Wiring Diagram
- Group 30 — Starting Motor
- Group 35 — Alternator

000

Copyright © 1980
DEERE & COMPANY
Moline, Illinois

All rights reserved

CONTENTS — Continued**SECTION 50 — POWER TRAIN**

- Group 00 — Specifications and Special Tools
- Group 05 — Engine Clutches and Clutch Linkages
- Group 10 — Hi-Lo Shift Unit
- Group 15 — Reverser Transmission
- Group 20 — Synchronized Transmission and Transmission Oil Pump
- Group 25 — Collar Shift Transmission and Transmission Oil Pump
- Group 30 — Differential
- Group 35 — Final Drives
- Group 40 — Independent PTO Shaft
- Group 45 — Continuous-Running PTO
- Group 50 — Mechanical Front Wheel Drive

SECTION 60 — STEERING SYSTEM AND BRAKES

- Group 00 — Specifications and Special Tools
- Group 05 — Power Steering
- Group 10 — Brakes

SECTION 70 — HYDRAULIC SYSTEM

- Group 00 — Specifications and Special Tools
- Group 05 — Hydraulic System Operation
- Group 06 — Hydraulic System Tests
- Group 10 — Oil Reservoir, Filter, Valves and Oil Cooler
- Group 15 — Hydraulic Pump
- Group 20 — Rockshaft
- Group 25 — Selective Control Valves and Breakaway Coupler
- Group 30 — Remote Cylinder

SECTION 80 — MISCELLANEOUS

- Group 00 — Specifications
- Group 05 — Front Axle
- Group 10 — Belt Pulley
- Group 15 — Front and Rear Wheels
- Group 20 — ROLL-GARD® Protective Structure
- Group 25 — Operator's Station

<https://www.ebooklibonline.com>

Hello dear friend!

Thank you very much for reading.

Enter the link into your browser.

The full manual is available for immediate download.

<https://www.ebooklibonline.com>

Section 10

GENERAL

CONTENTS OF THIS SECTION

	Page		Page
GROUP 00 — SPECIFICATIONS AND SPECIAL TOOLS		GROUP 05 — PREDELIVERY, DELIVERY AND AFTER-SALES INSPECTIONS	
Specifications	10-00-3	Tractor Storage	10-05-1
Serial Numbers	10-00-3	Predelivery Inspection	10-05-2
Model Numbers	10-00-3	Delivery Inspection	10-05-8
Engine	10-00-3	After-Sales Inspection	10-05-8
Engine Clutch	10-00-4		
Cooling System	10-00-4	GROUP 10 — LUBRICATION AND SERVICE	
Fuel System	10-00-4	Lubrication and Service	10-10-1
Electrical System	10-00-5		
Synchronized Transmission	10-00-5	GROUP 15 — TUNE-UP	
Collar Shift Transmission	10-00-5	Preliminary Engine Testing	10-15-1
Hi-Lo Shift Unit	10-00-5	Dynamometer Test	10-15-1
Reverser Transmission	10-00-5	Testing Compression Pressure	10-15-2
Differential and Final Drives	10-00-6	Tune-up	10-15-3
Differential Lock	10-00-6	Checking Tractor Operation	10-15-8
PTO	10-00-6	Standard Torques	10-15-9
Mechanical Front Wheel Drive	10-00-7		
Power Steering	10-00-7	GROUP 20 — TRACTOR SEPARATION	
Foot Brakes	10-00-7	Separating Between Engine and	
Handbrake	10-00-7	Tractor Front End	10-20-1
Hydraulic System	10-00-7	Removal and Installation of	
Capacities	10-00-7	Engine	10-20-5
Travel Speeds	10-00-8	Removal and Installation of	
Front and Rear Wheels	10-00-8	Clutch Housing	10-20-7
Dimensions and Weights	10-00-8	Removal and Installation of	
Predelivery, Delivery and		Final Drives	10-20-9
After-Sales Inspections	10-00-10	Removal and Installation of	
Lubrication and Service	10-00-11	Rockshaft	10-20-10
Tune-up	10-00-12		
Tractor Separation	10-00-13		
Standard Torques	10-00-14		
Special Tools	10-00-16		

Group 05

PREDELIVERY, DELIVERY AND AFTER-SALES INSPECTIONS

The John Deere Delivery Receipt, when properly filled out and signed by the dealer and customer, verifies that the predelivery and delivery services were satisfactorily performed. When delivering this machine, give the customer his copy of the delivery receipt and the operator's manual. Explain their purpose to him.

An inspection tag (Predelivery Information) is attached to each carefully tested new tractor before it leaves the factory.

According to this inspection tag the dealer will carry out a predelivery inspection including the repair of any possible shipping damage and giving the finishing touches to the tractor.

After the first 50 to 100 operating hours it is very important that the dealer carries out a further inspection. This is to ensure complete customer satisfaction and to make sure that the tractor is in good operating condition.

After completing the factory-recommended dealer checks and services listed on the predelivery inspection tag, send a copy to the factory and file the original with the shop order for the job. This will certify that the tractor has received proper delivery service.

TRACTOR STORAGE

When storing a new tractor, proceed as follows:

SHORT-TERM (UNDER 30 DAYS)

1. Fill full tank. This prevents condensation of moisture in tank.

2. Check engine oil level, transmission-hydraulic oil level, and coolant level. Add oil or coolant if necessary. During cold weather, be sure coolant contains sufficient anti-freeze.

3. Check electrolyte level in batteries. If electrolyte does not cover plates, add distilled water. Make sure batteries are fully charged.

4. Store tractor in a dry, protected place. If necessary to store tractor outside, cover it with a protective material. Protect tires from heat, sunlight, and petroleum products.

LONG TERM (OVER 30 DAYS)

To protect engine, fuel system, transmission and hydraulic system, use AR 41785 Rust Inhibitor. The above part no. includes one can of rust inhibitor, masking tape and protective caps to cover all engine openings.

Protect the engine as follows:

1. Add 300 c.c. (9 oz.) of rust inhibitor to the engine oil.

2. Add 225 c.c. (7.5 oz.) of rust inhibitor to the oil in the transmission/hydraulic system.

3. Drain fuel tank, pour 150 c.c. (5 oz.) of rust inhibitor into the empty tank and add approx. 10 liters (2.6 U.S. gals.) of fuel. Start engine and operate it at fast idle for 15 to 20 minutes to distribute the mixture through the whole fuel system. While the engine is running, operate the complete hydraulic system several times. Shut off engine in time to leave some fuel in the tank. Then allow the engine to cool down for 15 to 20 minutes.

4. Prepare 15 c.c. (0.5 oz.) of rust inhibitor for each cylinder. Remove plug of intake manifold or connecting pipe of starting fluid adapter at the

intake manifold, whichever applies, inject rust inhibitor into the intake manifold. Pull out shut-off knob and crank engine with starter several times.

However, do not allow the engine to start. Otherwise the whole procedure must be repeated.

After the rust inhibitor has been added, the engine may not be started again.

IMPORTANT! Rust inhibitor agents evaporate very easily. For this reason, seal all openings after the inhibitor has been added. Also, always keep the inhibitor container closed.

5. Fill the fuel tank.
6. Remove batteries. Add distilled water, if necessary. Charge the batteries and store in a cool, dry place where they will not freeze.
7. Seal all openings such as the vent tube and exhaust outlet.
8. Slacken fan belt and air conditioning compressor belt (if equipped).
9. Replace or repair damaged parts. Touch up any painted surfaces which are scratched or chipped.
10. Coat exposed metal surfaces, such as axles and piston rods of hydraulic cylinders, with grease or corrosion preventative.
11. Store the tractor in a dry, protected place. If the tractor is stored outside, cover it with a waterproof tarpaulin.
12. Block up the tractor so that tires do not touch the ground. Protect tires from heat and sunlight.

REMOVING TRACTOR FROM STORAGE

1. Remove all protective coverings.
2. Check crankcase and transmission/hydraulic system oil levels.
3. Check coolant level.
4. Check tire inflation pressure.
5. Install batteries and connect cable and ground strap.
6. Adjust fan belt and compressor belt (if equipped) tension.
7. Carry out 500-hour check.
8. Run engine at approx. 1500 rpm for some minutes. Check all systems before placing tractor under load.

PREDELIVERY INSPECTION

Before delivering the tractor to the customer, the following checks and services should be performed by the dealer:

ENGINE

Leaks

1. Check engine and fuel lines for leaks. Repair as necessary.

Checking Crankcase Oil Level

NOTE: Tractor should be on a level surface when oil level is checked. If it is not, check only to make sure the crankcase is not dry. Recheck oil level later, when tractor is on level ground.



1—Dipstick
2—Filler Cap

Fig. 1 — Engine Oil Dipstick and Filler Cap

1. Pull out dipstick (1, Fig. 1) and check oil level.

2. If necessary, add oil to bring oil level to top mark on dipstick. Use John Deere TORQ-GARD SUPREME® engine oil SAE 10W-20 or an equivalent oil.

Checking Coolant Level

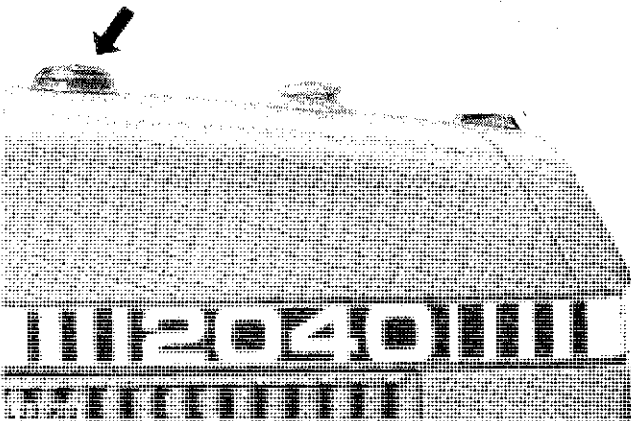

Fig. 2 — Radiator Filler Cap

1. Remove radiator filler cap and check coolant level. Coolant level must be midway between the filler neck and top of radiator core.

2. If necessary, add coolant to obtain this level. Use permanent type, ethylene glycol antifreeze which contains a rust inhibitor but does not contain a stop leak-additive.

Idle Speeds

1. Warm up engine to operating temperature and check slow and fast idle speeds. Adjust, if necessary (see Section 30, Group 30).

2. Slow idle speed: 800 rpm

3. Fast idle speed: 2660 rpm

Engine Shut-Off Cable

1. Check operation of shut-off cable. Move hand throttle lever completely forward and idle engine for 1 to 2 minutes.

2. Completely pull out shut-off knob, making sure engine stops immediately.

3. If necessary, adjust shut-off cable (see Section 30, Group 30).

Air Cleaner and Safety Element

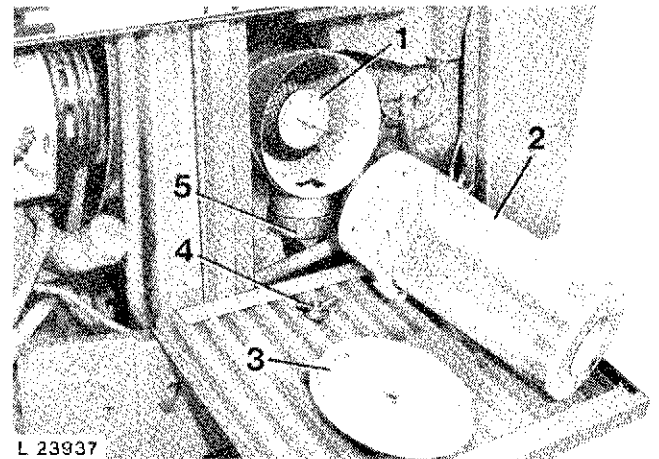

1—Safety Element
2—Air Cleaner Element
3—Cover
4—Wing Nut
5—Dust Unloading Valve

Fig. 3 — Air Cleaner and Safety Element

1. Check air cleaner and safety elements for proper installation.

2. Make sure that dust unloading valve (5, Fig. 3) (rubber cap) is installed on air cleaner.

Air Intake Connections

1. Check air intake connections for tightness. Tighten any loose clamps.

Exhaust Stack

1. Install exhaust stack, making sure it is in vertical position.

2. Install exhaust stack flap. When closed, flap should not contact exhaust stack end. If necessary, clamp flap to exhaust stack to obtain a clearance of 2 mm (0.08 in.) between flap and stack end.

Checking V-Belt Tension

Fan Belt

1. The fan belt should have 19 mm (3/4 in.) flex with 90 N (20 lbs) pull midway between crankshaft and alternator or water pump (use a spring scale).

ELECTRICAL SYSTEM

Batteries

1. Check battery terminals and battery cable ends. If they are corroded, clean and coat them with petroleum jelly.

2. Check electrolyte level in each battery cell. Add distilled water if necessary to bring level above cell plates.

3. If batteries are not fully charged, charge them. Remove battery caps when changing the battery.

Important Notes

1. If the engine is to be run for a short time without battery (using a slave battery for starting), do not, under any circumstances, interrupt the circuit by switching off the main switch before stopping the engine by means of the fuel pump shut-off cable. Further it is recommended to use additional current (lights) while engine is running. Do not run engine at a speed above 1000 rpm. Insulate battery end of disconnected starter cable properly to avoid damage to alternator and regulator.

2. Connect batteries or battery charger in the proper polarity. If they are improperly connected, the rectifier diodes will be immediately destroyed.

Start Safety Switch

1. Check operation of start safety switch.

2. If the starting motor does not work although the main switch is in starting position and the range shift lever is in neutral position, check the start safety switch by installing a new switch and check circuit (see Section 40, Group 15).

IMPORTANT! Do not overtighten switch when installing it in the rockshaft housing. Tighten switch to maximum torque of 50 N·m (5 mkp; 35 ft-lbs).

Lighting System

1. Check lighting system and repair as necessary. Replace any defective bulbs (see Section 40, Group 20).

2. Check headlight adjustment and correct, if necessary (see Section 40, Group 20).

Controls and Instruments

1. Check controls and instruments for proper operation.

NOTE: On tractors with collar shift transmission, transmission oil pressure indicator light glows only when there is a malfunction.

POWER TRAIN

Checking Transmission/Hydraulic System Oil Level

1. With the tractor on level ground, run the engine 2 to 3 minutes.
2. Place range and gear shift lever in neutral position.
3. Apply handbrake.
4. Lower draft links.
5. Run engine at slow idle (800 rpm).

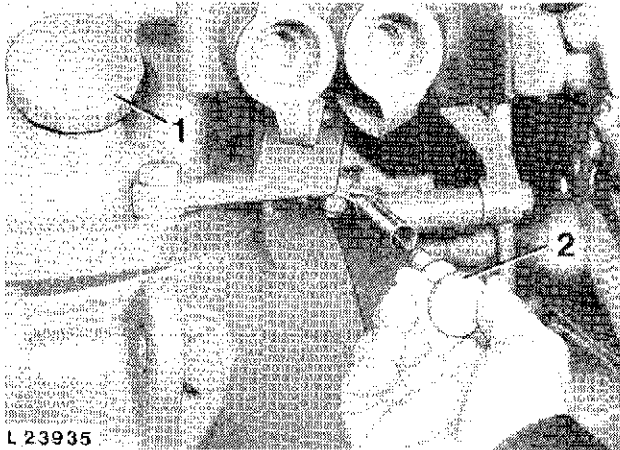

1—Filler Cap
2—Dipstick

Fig. 4 — Transmission/Hydraulic System Dipstick and Filler Cap on Tractors with Synchronized Transmission

6. Pull out dipstick and wipe clean.
7. Insert dipstick. Remove dipstick and check oil level.
8. If necessary, add John DEERE HY-GARD® Transmission and Hydraulic Oil or equivalent oil to bring oil level to top mark on dipstick.

NOTE: Types of oil not meeting our specifications will not give satisfactory service and may result in eventual damage.

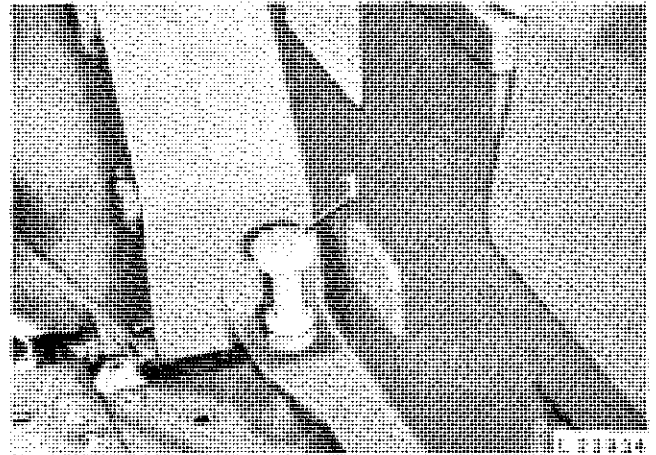

1—Dipstick

Fig. 5 — Transmission/Hydraulic System Dipstick on Tractors with Collar Shift Transmission

Transmission

1. Check transmission for proper operation.
2. While driving tractor, shift transmission through all gears. If transmission does not function properly, refer to Section 50, Group 20 or 25.

Differential Lock

1. Check differential lock for proper operation. If you find any problem, refer to Section 50, Group 30.

PTO

1. Check PTO operation. For this purpose, run engine and move PTO control lever to engaged and disengaged position. If PTO does not operate properly, refer to Section 50, Group 40 or 45.

Hi-Lo Shift Unit

Check Hi-Lo Shift Unit as Follows:

1. Operate tractor in both high and low ranges, carefully observing both operations.
2. Use the brakes to simulate a load condition on the tractor.
3. Low oil pressure will be indicated by disk pack slippage, which causes the clutch pack to become noisy.
4. A mechanical failure in the Hi-Lo shift unit will also be indicated by unusual noise.
5. If you find any problems, refer to Section 50, Group 10.

Clutch Pedal

1. Check clutch pedal free travel. It should be 25 mm (1 in.).
2. Make sure that clutch is fully disengaged before pedal contacts stop bracket. Adjust clutch pedal free travel, if necessary (see Section 50, Group 05).

Mechanical Front Wheel Drive

Checking Axle Housing Oil Level

1. Remove level plug (1, Fig. 6). Oil should be level with plug bore.
2. If necessary, top up with oil, using EP transmission oil (SAE 90) according to specification MIL-L-2105 B.

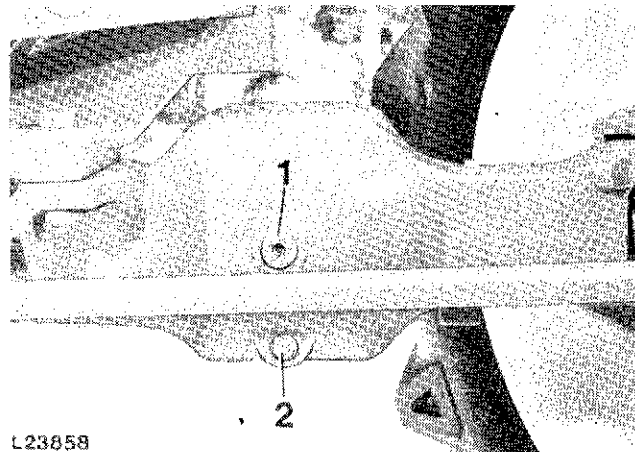

L23858

- 1—Level Plug
2—Drain Plug

Fig. 6 — Checking Axle Housing Oil Level

Checking Final Drives Oil Level

1. Turn wheel until mark (3, Fig. 7) is in level position.
2. Remove level plug (2). Oil should be level with plug bore.

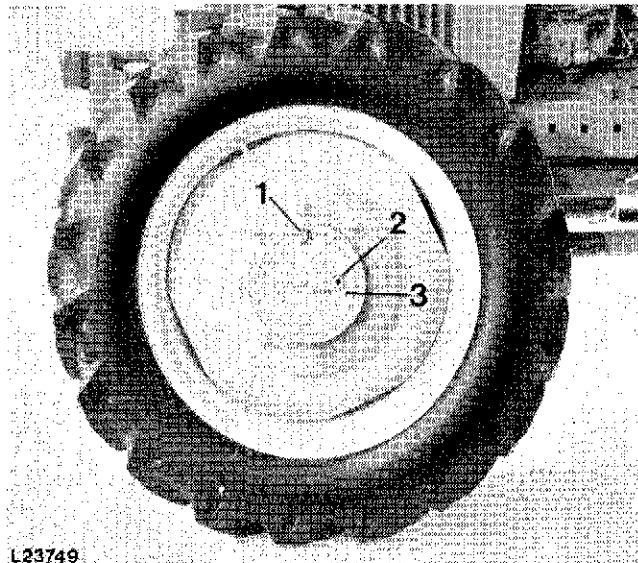

L23749

- 1—Drain Plug
2—Level Plug
3—Oil Level Mark

Fig. 7 — Checking Final Drives Oil Level

3. Add oil, if necessary, using EP transmission oil (SAE 90) according to specification MIL-L-2105 B.

MFWD Operation

1. Check MFWD for proper operation. If you find any problems, refer to section 50, Group 50.

STEERING AND BRAKES**Steering**

1. Check steering system for proper operation. In case of a malfunction, refer to Section 60, Group 05.

Brakes

1. Check footbrakes and handbrake for proper operation. Adjust brakes, if necessary. Refer to Section 60, Group 10 if a malfunction occurs.

HYDRAULIC SYSTEM**Three-Point Hitch**

1. Free lift arms.
2. Install and/or adjust draft links and center link (see operator's manual).

Rockshaft

1. Check rockshaft operation. In case of a malfunction, refer to Section 70, Group 20.

Selective Control Valves

1. Check operation of selective control valves.

Leaks

1. Check entire hydraulic system for leaks. Repair or replace components as necessary.

MISCELLANEOUS**Wheel Bolts**

1. Tighten all wheel bolts to the specified torque. See Section 80, Group 05.

Tire Pressures

1. Check tire pressures (see operator's manual).

Tread Width

1. Adjust tread width to customer's needs (see operator's manual).

Toe-In

1. Check toe-in and adjust, if necessary (see Section 80, Group 05).

Lubricating Points

1. Lubricate all lubricating points on tractor.

ROLL-GARD

1. Check ROLL-GARD for proper installation.
2. Tighten cap screws to specified torque (see Section 80, Group 20).

Guards

1. Check all guards for proper installation.

Operator's Seat

1. Check whether operator's seat can be adjusted properly.
2. Check seat belt for proper condition and correct installation.
3. Remove plastic cover from SMV (Slow Moving Vehicle) emblem and install emblem on back of operator's seat.

Decals and Paint

1. Check decals and paint for proper condition.

DELIVERY INSPECTION

A thorough discussion of the operation and service of the tractor at the time of its delivery helps to assure complete customer satisfaction.

Proper delivery should be an important phase of the dealer's program.

It is a well-known act that many complaints have arisen simply because the owner was not shown how to operate and service his new tractor properly. Therefore, enough time should be devoted, at the customer's convenience, to introducing him to his new tractor and explaining to him how to operate and service it.

Using the tractor operator's manual as a guide, be sure that the owner understands the following points properly:

1. Operation of control levers and instruments
2. Starting and shutting off the engine
3. The importance of the tractor break-in period
4. Use of counterweights and proper tire inflation pressure as well as filling of tires with water and calcium chloride, if required
5. All functions of the hydraulic system
6. Operating the PTO and belt pulley (if equipped)
7. The importance of the safety rules
8. The importance of lubrication and periodic service

Give particular emphasis to sway blocks, rockshaft speed-of-drop, rockshaft selector lever (load and depth control), transmission oil pressure indicator light, engine oil pressure indicator light (whether temperature or pressure and what to do if lights go on) and alternator indicator light (indicating whether alternator is charging). These areas are very often misunderstood.

AFTER-SALES INSPECTION

In the interest of the purchaser and the dealer an after-sales inspection should be carried out by the dealer after the first 100 hours of using a new John Deere tractor.

The purpose of this inspection is to make sure that the customer is receiving satisfactory performance from his tractor. At the same time, the inspection should reveal whether or not the tractor is being operated, lubricated and serviced properly.

Through this inspection a needless volume of service work can be eliminated by preventing minor difficulties from developing into serious problems later on. It also will promote stronger dealer-customer relations and give the customer an opportunity to ask questions that may have arisen during the first few days of use.

Thereby the dealer has the further opportunity of promoting the possible sale of other new equipment.

The following inspection program is recommended:

ENGINE

Leaks

1. Check engine and fuel lines for leaks. Repair as necessary.

Checking Crankcase Oil Level

NOTE: Tractor should be on a level surface when oil level is checked. If it is not, check only to make sure the crankcase is not dry. Recheck oil level later, when tractor is on level ground.

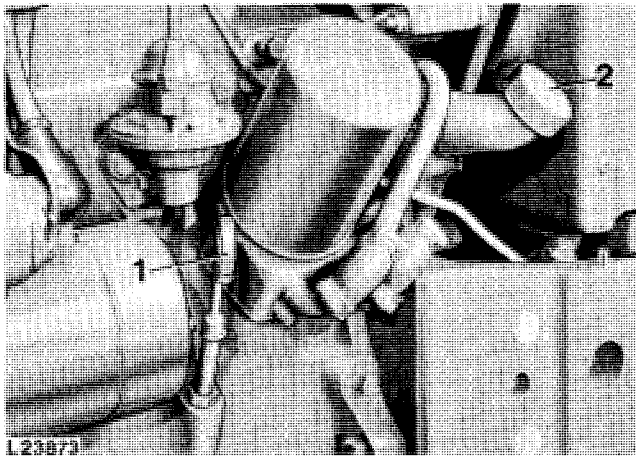

1—Dipstick
2—Filler Cap

Fig. 8 — Engine Oil Dipstick and Filler Cap

1. Pull out dipstick (1, Fig. 8) and check oil level.

2. If necessary, add oil to bring oil level to top mark on dipstick. Use John Deere TORQ-GARD SUPREME engine oil SAE 10W-20 or an equivalent oil.

Checking Valve Clearance

1. Using a feeler gauge, check valve clearance (see Section 20, Group 10).

Valve clearance (with the engine cold or warm)
Intake valve0.35 mm (0.014 in.)
Exhaust valve0.45 mm (0.018 in.)

Checking Coolant Level

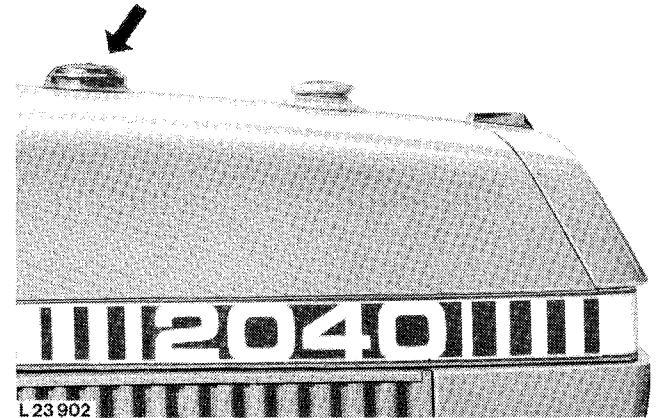

Fig. 9 — Radiator Filler Cap

1. Remove radiator filler cap and check coolant level. Coolant level must be midway between the filler neck and top of radiator core.

2. If necessary, add coolant to obtain this level. Use permanent type, ethylene glycol antifreeze which contains a rust inhibitor but does not contain a stop leak-additive.

Idle Speeds

1. Warm up engine to operating temperature and check slow and fast idle speeds. Adjust, if necessary (see Section 30, Group 30).

2. Slow idle speed: 800 rpm

3. Fast idle speed: 2660 rpm

Hand Throttle Lever

1. Check whether hand throttle lever can be moved properly. Adjust, if necessary.

Engine Shut-Off Cable

1. Check operation of shut-off cable. Move hand throttle lever completely forward and idle engine for 1 to 2 minutes.
2. Completely pull out shut-off knob, making sure engine stops immediately.
3. If necessary, adjust shut-off cable (see Section 30, Group 30).

Air Cleaner and Safety Element

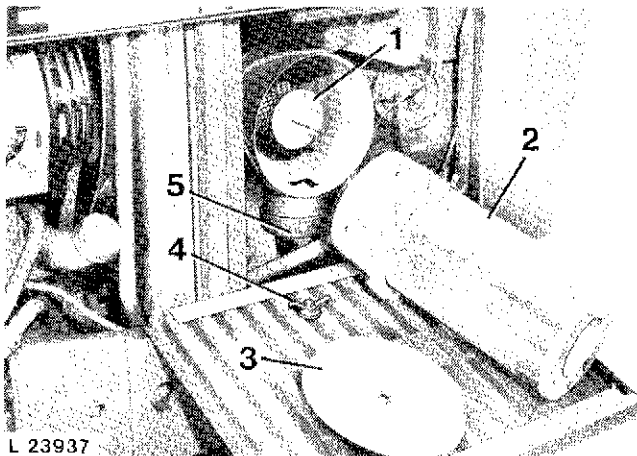

L 23937

- | | |
|-----------------------|------------------------|
| 1—Safety Element | 4—Wing Nut |
| 2—Air Cleaner Element | 5—Dust Unloading Valve |
| 3—Cover | |

Fig. 10 — Air Cleaner and Safety Element

1. Check air cleaner and safety elements for proper installation.
2. Make sure that dust unloading valve (5, Fig. 10) (rubber cap) is installed on air cleaner.

Air Intake Connections

1. Check air intake connections for tightness. Tighten any loose clamps.

Checking V-Belt Tension

Fan Belt

1. The fan belt should have 19 mm (3/4 in.) flex with 90 N (20 lbs) pull midway between crankshaft and alternator or water pump (use a spring scale).

ELECTRICAL SYSTEM

Batteries

1. Check battery terminals and battery cable ends. If they are corroded, clean and coat them with petroleum jelly.
2. Check specific gravity of battery cells. At an electrolyte temperature of 20°C (68°F), a fully charged battery should have a specific gravity of 1.28 under normal and arctic conditions and 1.23 in tropical areas.
3. Check electrolyte level in each battery cell. Add distilled water if necessary to bring level above cell plates.
4. If batteries are not fully charged, charge them. Remove battery caps when charging the battery.

Important Notes

1. If the engine is to be run for a short time without battery (using a slave battery for starting), do not, under any circumstances, interrupt the circuit by switching off the main switch before stopping the engine by means of the fuel pump shut-off cable. Further, it is recommended to use additional current (lights) while engine is running. Do not run engine at a speed above 1000 rpm. Insulate battery end of disconnected starter cable properly to avoid damage to alternator and regulator.
2. Connect batteries or battery charger in the proper polarity. If they are improperly connected, the rectifier diodes will be immediately destroyed.

Start Safety Switch

1. Check operation of start safety switch.
2. If the starting motor does not work although the main switch is in starting position and the range shift lever is in neutral position, check the start safety switch by installing a new switch and check circuit (see Section 40, Group 15).

IMPORTANT! Do not overtighten switch when installing it in the rockshaft housing. Tighten switch to maximum torque of 50 N•m (35 ft-lbs).

Lighting System

1. Check lighting system and repair as necessary. Replace any defective bulbs (see Section 40, Group 20).
2. Check headlight adjustment and correct, if necessary (see Section 40, Group 20).

Controls and Instruments

1. Check controls and instruments for proper operation.

POWER TRAIN

Checking Transmission/Hydraulic System Oil Level

1. With the tractor on level ground, run the engine 2 to 3 minutes.
2. Place range and gear shift lever in neutral position.
3. Apply handbrake.
4. Lower draft links.
5. Run engine at slow idle (800 rpm).

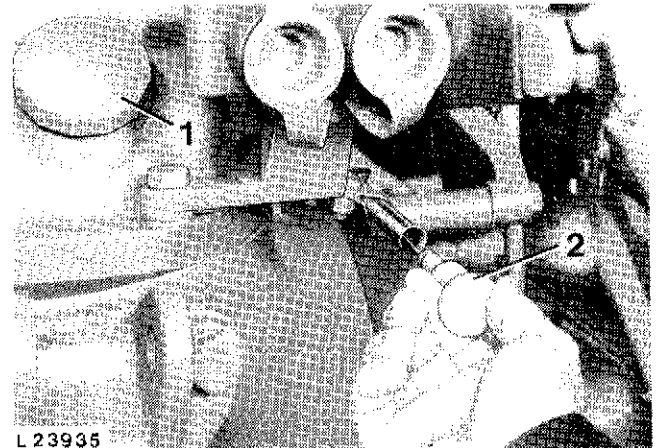

1—Filler Cap
2—Dipstick

Fig. 11 — Transmission/Hydraulic System Dipstick and Filler Cap on Tractor with Synchronized Transmission

6. Pull out dipstick and wipe clean.
7. Insert dipstick. Remove dipstick and check oil level.
8. If necessary, add John Deere HY-GARD Transmission and Hydraulic Oil or equivalent oil to bring oil level to top mark on dipstick.

NOTE: Types of oil not meeting our specifications will not give satisfactory service and may result in eventual damage.

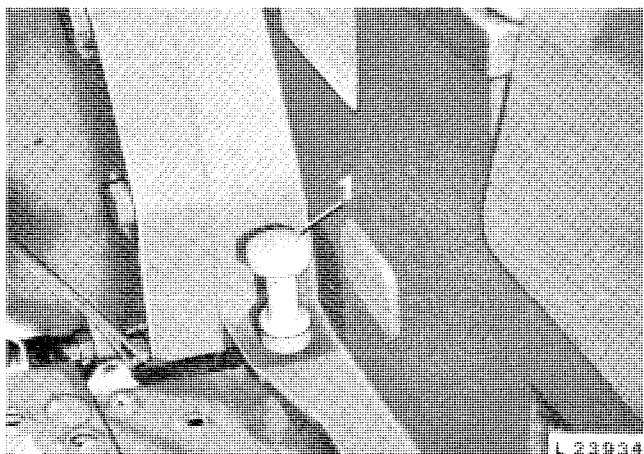

1—Dipstick

Fig. 12 — Transmission/Hydraulic System Dipstick
on Tractors with Collar Shift Transmission

Transmission

1. Check transmission for proper operation.
2. While driving tractor, shift transmission through all gears. If transmission does not function properly, refer to Section 50, Group 20 or 25.

Differential Lock

1. Check differential lock for proper operation. If you find any problem, refer to Section 50, Group 30.

PTO

1. Check PTO operation. For this purpose, run engine and move PTO control lever to engaged and disengaged position. If PTO does not operate properly, refer to Section 50, Group 40 or 45.

Hi-Lo Shift Unit

Check Hi-Lo Shift Unit as Follows:

1. Operate tractor in both high and low range, carefully observing both operations.
2. Use the brakes to simulate a load condition on the tractor.
3. Low oil pressure will be indicated by disk pack slippage, which causes the clutch pack to become noisy.
4. A mechanical failure in the Hi-Lo shift unit will also be indicated by unusual noise.
5. If you find any problems, refer to Section 50, Group 10.

Clutch Pedal

1. Check clutch pedal free travel. It should be approx. 25 mm (1 in.).
2. Make sure that clutch is fully disengaged before pedal contacts stop bracket. Adjust clutch pedal free travel, if necessary (see Section 50, Group 05).

Mechanical Front Wheel Drive

Checking Axle Housing Oil Level

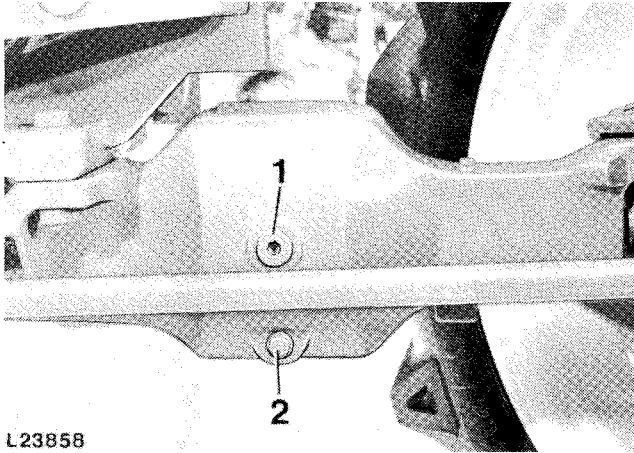

L23858

- 1—Level Plug
- 2—Drain Plug

Fig. 13 — Checking Axle Housing Oil Level

1. Remove level plug (1, Fig. 13). Oil should be level with plug bore.

2. If necessary, top up with oil, using EP transmission oil (SAE 90) according to specification MIL-L-2105 B.

Checking Final Drives Oil Level

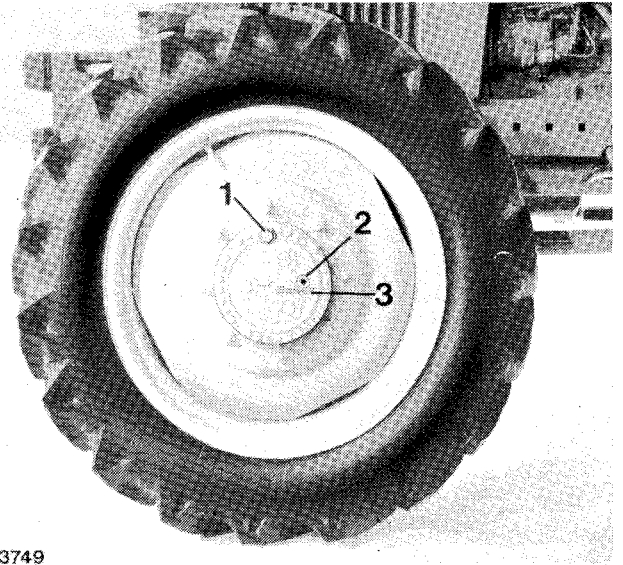

L23749

- 1—Drain Plug
- 2—Level Plug
- 3—Oil Level Mark

Fig. 14 — Checking Final Drives Oil Level

1. Turn wheel until mark (3, Fig. 14) is in level position.

2. Remove level plug (2). Oil should be level with plug bore.

3. Add oil, if necessary, using EP transmission oil (SAE 90) according to specification MIL-L-2105 B.

MFWD Operation

1. Check MFWD for proper operation. If you find any problems, refer to Section 50, Group 50.

STEERING AND BRAKES**Steering**

1. Check steering system for proper operation. In case of a malfunction, refer to Section 60, Group 05.

Brakes

1. Check footbrakes and handbrake for proper operation. Adjust brakes, if necessary. Refer to Section 60, Group 10 if a malfunction occurs.

HYDRAULIC SYSTEM**Rockshaft**

1. Check rockshaft operation. In case of a malfunction, refer to Section 70, Group 20.

Selective Control Valves

1. Check operation of selective control valves.

Leaks

1. Check entire hydraulic system for leaks. Repair or replace components as necessary.

MISCELLANEOUS**Guards**

1. Check all guards for proper installation.

ROLL-GARD

1. Check ROLL-GARD for proper installation.
2. Tighten cap screws to specified torque (see Section 80, Group 15).

Operator's Seat

1. Check whether operator's seat can be adjusted properly.
2. Check seat belt for proper condition and correct installation.

Group 10 LUBRICATION AND SERVICE

Effective use of lubricating oils and greases is perhaps the most important step toward low upkeep cost, long tractor life, and satisfactory service. Use only lubricants specified in this section. Apply them at intervals and according to the instructions in the operator's manual.

ENGINE LUBRICATING OIL

Choice of oil is first determined by the operating conditions (see chart below).

OIL SPECIFICATIONS

Operating Conditions	API Specification SAE J 183 a	MIL Specification
For light and medium operating conditions and when using fuel with less than 0.5% sulphur content	CC	MIL-L-46152 MIL-L-2104 B
For heavy operating conditions and when using fuel with more than 0.5% sulphur content	CD	MIL-L-2104 C

NOTE: Use of SAE 5 W or SAE 5 W-20 may cause some increase in oil consumption. Check oil level more frequently when using these oils.

Depending on the lowest expected atmospheric temperature at start for the fill period, use oil of viscosity as shown in Fig. 1.



L12122

John Deere TORQ-GARD SUPREME engine oil or other noted brands of oil that meet the specifications are recommended for use in the engine crankcase.

OIL VISCOSITY

Single Viscosity

Multi Viscosity

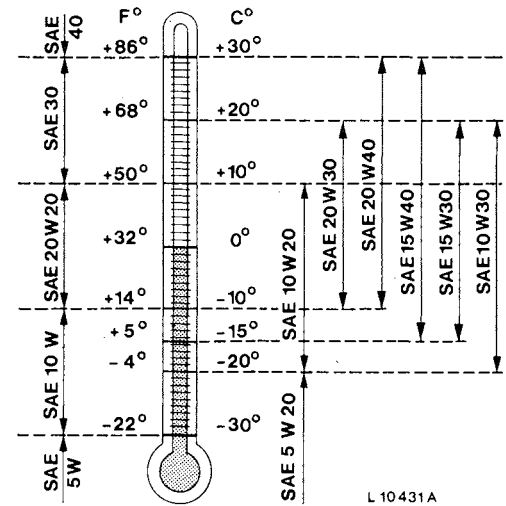

Fig. 1 — Oil Viscosity at Temperature Expected

TRANSMISSION-HYDRAULIC OIL

Use John Deere HY-GARD Transmission and Hydraulic Oil (JDM J 20 A) or equivalent oil in the transmission and hydraulic system.

Other types of oil will not give satisfactory service and may result in eventual damage.

OIL FOR MECHANICAL FRONT WHEEL DRIVE

Use an EP-transmission oil (SAE 90) according to specification MIL-L-2105 B.

GREASE

Lithium saponified multipurpose grease (JDM J13 C3) or its equivalent is recommended for all grease fittings. Grease must be free of dust and other contamination.

Grease the tractor only when the engine is not running!

Clean grease fittings prior to greasing!

STORING LUBRICANTS

The tractor can operate at top efficiency only if clean lubricants are used. Use clean containers to handle all lubricants. Store them in an area protected from dust, moisture, and other contamination.

GENERAL INFORMATION

Carefully written and illustrated instructions are included in the tractor operator's manual. Remind your customer to follow the recommendations in these instructions.

For your convenience when servicing the tractor, the following chart shows capacities for the various components.

Component	Capacity	Service Interval
Engine crankcase	Without filter change: 6.5 liters (1.70 U.S. gal.) With filter change: 7.0 liters (1.80 U.S. gal.)	Every 10 operating hours: check oil level Every 100 operating hours: oil change Every 200 operating hours: filter change*
Transmission/hydraulic system (including oil reservoir and oil cooler)		
Synchronized Transmission	Dry system: 57.0 liters 15.10 U.S. gal. Oil change: 49.0 liters 12.90 U.S. gal.	Every 50 operating hours: check oil level Every 500 operating hours: filter change** Every 1000 operating hours: oil change
Collar Shift Transmission (without reverser)	Dry system: 41 liters 10.80 U.S. gal. Oil change: 33.0 liters 8.70 U.S. gal.	Every 1000 operating hours: Clean hydraulic pump stroke control valve filter
Collar Shift Transmission (with reverser)	Dry system: 36.0 liters 9.5 U.S. gal. Oil change: 28.0 liters 7.4 U.S. gal.	
Oil Reservoir	4.0 liters (1.10 U.S. gal.)	
Oil Cooler	2.0 liters (0.50 U.S. gal.)	

*Replace crankcase filter element after the first 100 hours of operation. Thereafter replace filter element after every 200 hours of operation.

**Replace transmission/hydraulic filter element after the first 50 hours of operation, after the first 500 and thereafter every 500 hours of operation.

Component	Capacity	Service Interval
Mechanical front wheel drive	Axle housing: 5.3 liters (1.4 U.S. gal.) Final drives: 0.75 liters (0.2 U.S. gal.) each	Every 50 operating hours: check oil level Every 1000 operating hours: oil change

Component	Lubricant	Service Interval
Front wheel bearings	Wheel bearing grease	Every 1000 operating hours: clean and pack with grease
Grease fittings	Lithium saponified multipurpose grease (JDM J13 C3)	
Front axle and front wheels.....		Every 10 operating hours: lubricate
Rear axle bearings.....		In extremely wet and muddy conditions: lubricate every 10 operating hours. Under normal conditions: lubricate every 500 operating hours
Three-point hitch.....		Every 200 operating hours: lubricate

ENGINE CRANKCASE

Checking Oil Level

With the tractor on level ground and the engine stopped for 10 minutes or more, check crankcase oil level. If the oil level is down to the lower mark on the dipstick, add sufficient John Deere TORQ-GARD SUPREME Engine Oil or its equivalent of the proper viscosity to bring the level to the upper mark.

Service Interval: At predelivery and after every 10 hours.

Oil and Filter Change

NOTE: Drain oil with engine shut off, however with engine oil warm.

1. Remove drain plug.
2. While oil is draining, replace filter element (every 200 hours).

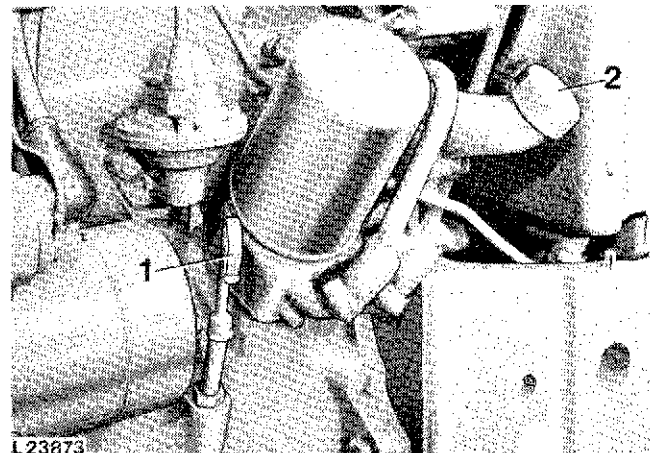

1—Dipstick
2—Filler Cap

Fig. 2 — Engine Oil Dipstick and Filler Cap

3. Remove filter element (turn counterclockwise) and clean mounting surface.



Suggest:

If the above button click is invalid.

Please download this document

first, and then click the above link

to download the complete manual.

Thank you so much for reading

4. Apply a thin film of oil to sealing ring of new filter. Tighten filter element until sealing ring touches mounting surface, then turn an additional 3/4 to 1-1/4 turns. Do not overtighten.

5. Reinstall drain plug.

6. Fill crankcase with fresh oil of the proper viscosity.

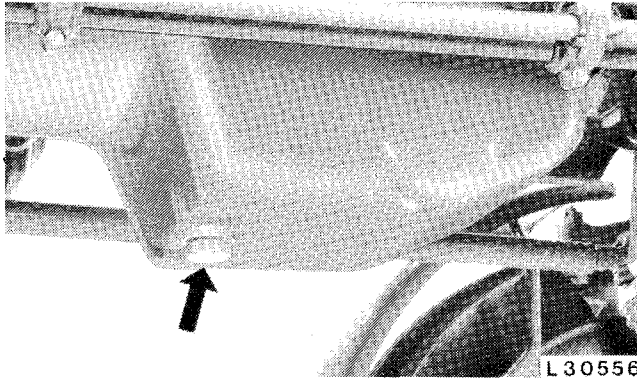

Fig. 3 — Crankcase Drain Plug

7. Crankcase capacity without filter change 6.5 liters (1.7 U.S. gal.), with filter change 7.0 liters (1.8 U.S. gal.).

8. Run engine for a short time and check for leaks at filter base and drain plug.

9. Stop engine.

10. Check oil level.

IMPORTANT! During cold weather operation with temperature below freezing point, change oil every 100 hours or every six weeks, whichever occurs first. Also change oil at any seasonal change in temperature when oil of a new viscosity is required.

Service Interval: Every 100 hours.

TRANSMISSION/HYDRAULIC SYSTEM

Checking Oil Level

1. With the tractor on level ground, run the engine 2 to 3 minutes.

2. Place range and gear shift lever in neutral position.

3. Apply handbrake.

4. Lower draft links.

5. Run engine at slow idle (800 rpm).

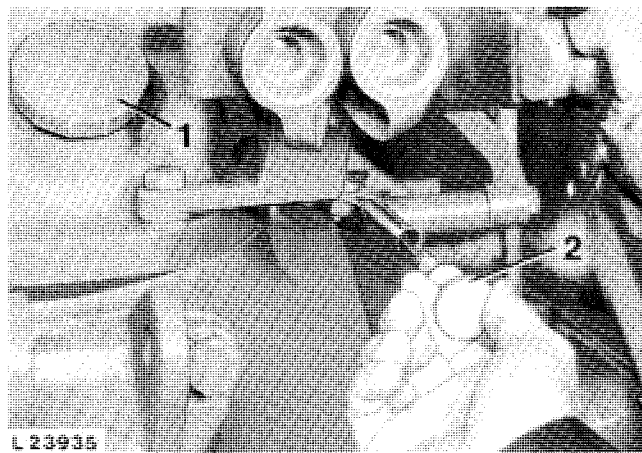

1—Filler Cap
2—Dipstick

Fig. 4 — Transmission/Hydraulic System Dipstick and Filler Cap

6. Pull out dipstick and wipe clean.

7. Insert dipstick. Remove dipstick and check oil level.

8. If necessary, add John Deere HY-GARD Transmission and Hydraulic Oil or equivalent oil to bring oil level to top mark on dipstick.

<https://www.ebooklibonline.com>

Hello dear friend!

Thank you very much for reading.

Enter the link into your browser.

The full manual is available for immediate download.

<https://www.ebooklibonline.com>