

848G Skidder

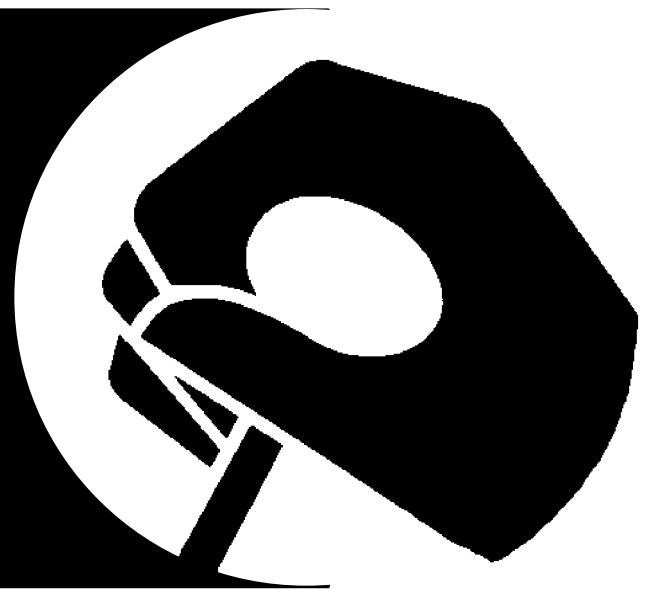

Technical Manual



John Deere Dubuque Works
TM1898 (Dec00)

ENGLISH

0. General Information

0010 How To Use This Book	0010 - 1
1. Serial Numbers	0010 - 1
2. Component Numbers	0010 - 1
3. Page Layout	0010 - 2
4. Abbreviations	0010 - 4
0020 Chapters and Sections Contents	0020 - 2
0030 Foreword and Warranty	0030 - 1
1. Foreword	0030 - 1
2. Customer Feedback	0030 - 4
3. Modifications or Repairs to Roll-over Protective Structures (ROPS)	0030 - 5
4. Non-approved Field Product Changes	0030 - 6
5. Sound Information	0030 - 7
6. Registered Trade Marks	0030 - 7
7. Warranty	0030 - 7
0040 Safety Information	0040 - 2
1. General	0040 - 2
2. Safety Symbol	0040 - 2
3. Understanding Signal Words	0040 - 2
4. Skidder Safety Features	0040 - 3
5. General Safety Precautions	0040 - 4
6. Operating Safety Precautions	0040 - 8
7. Servicing Safety Precautions	0040 - 16
8. Transporting on Public Roads	0040 - 27
9. Fire Prevention	0040 - 29
10. What to Do if the Machine Catches Fire	0040 - 30
11. Safety Signs	0040 - 31

11.1 848G Skidder Safety Decals	0040 - 31
0060 General - Component Locators	0060 - 1
1. General	0060 - 1
2. Component Locators	0060 - 2
2.1 Engine Compartment Locator	0060 - 2
2.2 Hydraulic Component Locator	0060 - 4
2.3 Electrical Component Locator	0060 - 5
2.4 Power Train Component Locator	0060 - 6
2.5 Cab Component Locator	0060 - 7
2.6 Frames Component Locator	0060 - 8
2.7 Tree Handling Component Locator	0060 - 9
0070 Towing / Transporting the Skidder	0070 - 1
1. Towing Over a Short Distance	0070 - 1
2. Releasing the Brakes	0070 - 2
3. Towing Procedure	0070 - 4
4. Transporting the Skidder	0070 - 5
5. Driving the Skidder on the Road	0070 - 6
0080 Repairs	0080- 1
1. Troubleshooting Techniques	0080- 1
2. Welding	0080- 2
3. Hydraulics	0080- 3
4. Storage	0080- 4
4.1 Preparing Machine for Storage	0080- 4
4.2 Monthly Storage Procedure	0080- 6
5. Periodic Maintenance Checklist	0080- 7

<https://www.ebooklibonline.com>

Hello dear friend!

Thank you very much for reading.

Enter the link into your browser.

The full manual is available for immediate download.

<https://www.ebooklibonline.com>

0010 How To Use This Book

1. Serial Numbers

This Manual covers the following range of 848G Skidder serial numbers:

2. Component Numbers

The manual is divided into Chapters. Chapter 1, for example, details the engine system and includes the engine mounting, cooling system, coupling, exhaust and air intake systems. Each chapter starts with a Table of Contents giving details and page references.

Each Chapter is further divided into smaller sections. Each section is identified with a unique number that relates to the warranty system. For example, all parts used in the engine air intake system are found under section 1700.

3. Page Layout

At the top of each page are two sets of numbers.

The 'page' number (A), at the outside corner, consists of the four digit section number followed by the page number in that section. Each section is numbered sequentially from one. For example, 1800 - 3, would be the third page of Section 1800, Exhaust System.

The 'Issue' number (B) also comprises two sets of numbers separated by a hyphen. The first numbers identify the issue date of that section of the manual. The numbers following the hyphen are the issue number of the section and are used to control updating in the field. For example, 06/2000 - 02, would indicate Revision 2, released June, 2000.

At the bottom of each page is a model identification and the type of manual (C). The model identification may identify a unique product or a range of products (848G Service Manual for example).

3. Page Layout

Issue
12/2000-01

Page
1100 - 1

1100 Engine

1. Description and Operation

1.1 General

The primary source of power for the skidder is a turbocharged, aftercooled, six cylinder John Deere engine.

Model	John Deere 6081AF
Cylinders	6
Displacement	8.1 Liters (496 cu. in.)
Rated Power (HP)	149 Kw (200 HP) @ 2200 RPM

The engine is mounted in front of the operator cab and provides power directly to the transmission via a flex-plate connector and hydrostatic torque converter system.

Power to the hydraulic pump and the transmission charge pump is mechanically transmitted around the torque converter. The air conditioning compressor is belt driven from the cooling fan hub.

848G Skidder Service Manual

4. Abbreviations

The abbreviations in the following list are common. While we have endeavored to use 'industry standard' abbreviations wherever possible, common practice mandates that historical usage be maintained.

ADJ	adjust; adjuster	F	Fahrenheit
ADPTR	adapter	FD	front drive
ALT	alternator	FH	flat head
ANG	angle	FLT	flat foot
ASSY	assembly	FT	feet
AUX	auxiliary	FTG	fitting
AWG	American Wire Gage	FWD	forward
BATT	battery	GP	group
BLK	black; block	GR	grapple
BLU	blue	GRN	green
BRG	bearing	HARN	harness
BRK	brake	HD	heavy duty
BS	bar saw	HDLNR	headliner
BU	backup	HH	hex head
BUSH	bushing	HP	high pressure
C	Celsius; Centigrade	HSG	housing
CARR	carrier	HYD	hydraulic
CBL	cable	ID	inside diameter
CF	carrier frame	IN	inch; inches
CHK	check	INCL	includes
CM	centimeter	INSTR	instrument
CMPRSR	compressor	INT	internal
CONV	converter	JS	joystick
CRDL	cradle	LF	left front
CS	capscrew	LG	long
CTR	circle saw center	LH	left hand
CUM	Cummins	LK	lock
CYL	cylinder	LP	low pressure
D	diameter	LR	left rear
DEG	degree(s)	LWR	lower
DL	delimber		
EL	elbow		
EMGCY	emergency		
ENG	engine		
EXT	extension		

4. Abbreviations

MACH	machine	SEC	section
MECH	mechanism	SH	socket head
MM	millimeter	SHT	sheet
MT	mount	SKT	socket
MTG	mounting; mating	SLTD	slotted
MTR	motor	SN	serial number
		SPCL	special
OBS	obsolete	SPD	speed
OD	outside diameter	SPI	single pump isolated
OPR	operator	SPRSN	suppression
OPT	optional	SQ	square
ORN	orange	STD	standard
PC	piece	TEMP	temperature
PF	power frame	TJ	Timberjack
PHIL	Phillips	TS	topping saw
PIN	pinion	TYP	typical
PKG	package		
PLCS	places	UPR	upper
PNL	panel		
PO	part of...	VIO	violet
PRESS	pressure	VLV	valve
PSI	pounds/square inch		
		W/	with
REF	reference	W/G	with guard
REINF	reinforce; reinforcing	W/O	without
REINFMT	reinforcement	WHT	white
REV	reverse	WLDMT	weldment
RF	right front	WS	windshield
RH	right hand	WSHR	washer
RLF	relief		
RND	round	5P	five port
RR	right rear	8P	eight port
		9P	nine port
		10P	ten port

1. Description and Operation

1.2 Primary Filter (Fuel/water Separator)

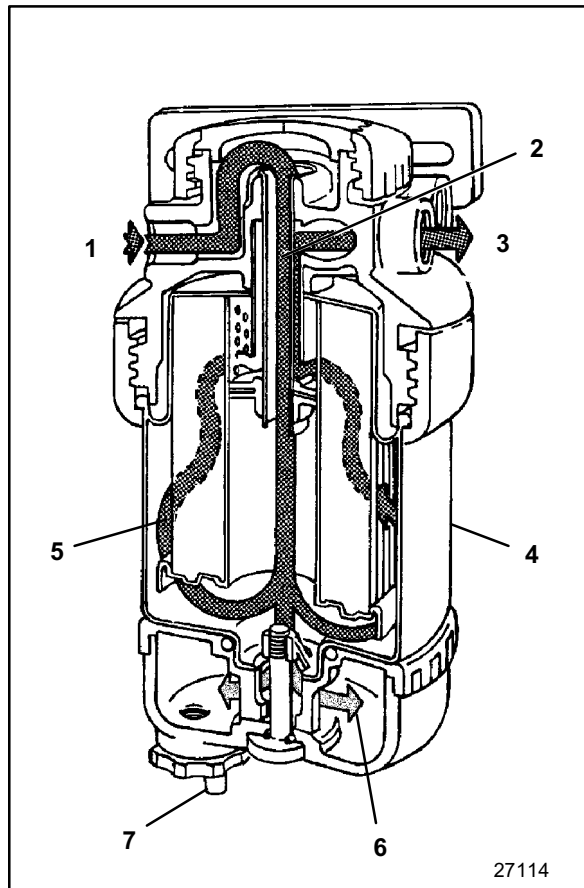

The primary fuel filter/water separator is a single-stage filter. Fuel enters the filter at the inlet, then flows to the center port, travels to the bottom of the filter element, onward to the outboard side of the filter, up the sides and back inward through the media before exiting filter through outlet to the fuel supply pump. The filter element is attached to the base with a threaded (detent) ring.

Water and contaminants settle at the bottom of the water separator (clear sediment bowl). A drain plug is provided to drain these contaminants from system.

1. Fuel Inlet
2. Center Port
3. Fuel Outlet
4. Filter Element
5. Fuel
6. Water and Contaminants
7. Drain Plug

1. Description and Operation

1.2 Primary Filter (Fuel/water Separator)

1. Primer Assembly
2. Retaining Ring
3. Cap
4. O-Ring
5. Stem
6. Plug
7. Filter Head
8. Filter Mounting Hardware
Cap Screw
Washer
9. Bleed Screw and O-Ring
10. Fitting and O-ring
11. Seal
12. Retaining Ring
13. Seal Kit
14. Filter Element
15. Water Separator Bowl

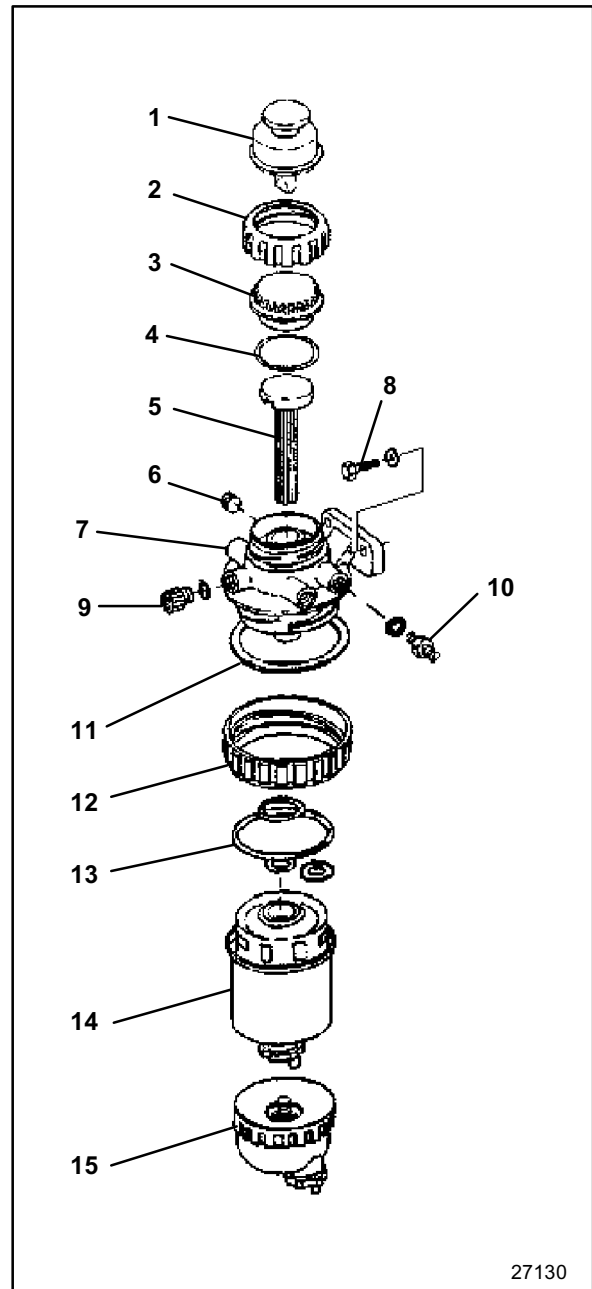

1. Description and Operation

1.3 Final Fuel Filter

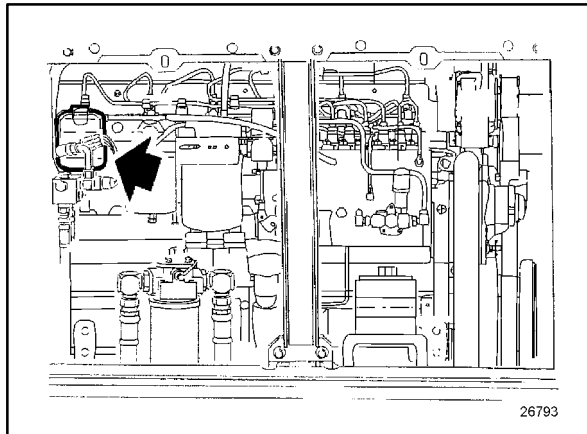

Fuel enters the filter through the inlet port and flows through a first and second stage filtering medias before flowing through outlet port to the injection pump.

The filtering media is housed in the metal sediment bowl and epoxied to the bowl as one assembly.

Since water and other contaminants may settle to the bottom of the sediment bowl, a drain plug is provided to permit their removal.

An air vent enables air in the fuel system to be expelled to the outside through the filters when bleed plug is loosened while pumping hand primer on fuel supply pump or primary fuel filter.

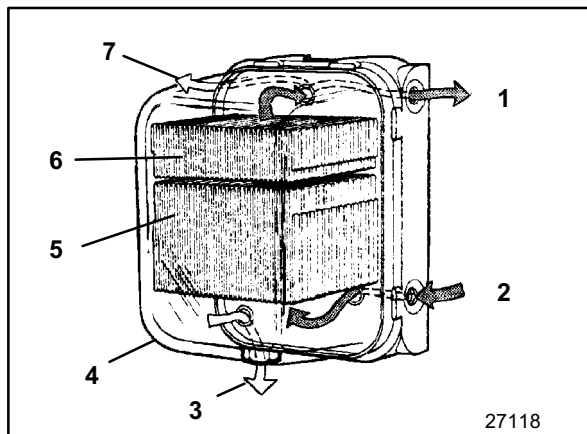

1. Outlet Port
2. Inlet Port
3. Drain Plug
4. Sediment Bowl
5. First Stage Filtering Media
6. Second Stage Filtering Media
7. Air Vent

1. Description and Operation

1.4 Fuel Supply Pump

The supply pump is mounted on the side of the injection pump housing and is driven by the injection pump camshaft. Fuel enters the supply pump through the inlet port, is pressurized by a plunger, and discharged through outlet port. The hand primer provides manual pump operation for bleeding air from the fuel system.

1. Outlet Port
2. Supply Pump
3. Inlet Port
4. Hand Primer

Robert Bosch and Denso plunger-type fuel supply pumps are used for 6081 engine applications.

Fuel supply pumps are furnished as complete assemblies for repair. Only the primer, washers, and fittings are available as separate parts.

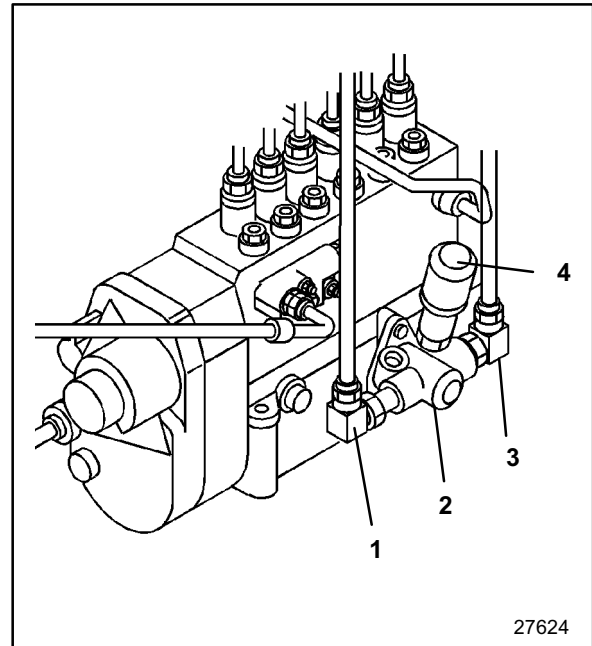

Note:

See the John Deere Operation and Maintenance Manual for Powertech 8.1 L 6081 OEM Diesel Engines (OMRG24828) and the John Deere Operation and Diagnostics Manual for Powertech 8.1 L 6081 OEM Diesel Engines (CTM 134) for more information on servicing the supply pump.

1. Description and Operation

1.5 Fuel Injection System

See the John Deere Operation and Diagnostics Manual for Powertech 8.1 L 6081 OEM Diesel Engines (CTM 134) for information on fuel injection system theory of operation and diagnostic testing procedures.

See the John Deere Repair Manual for Powertech 8.1 L 6081 OEM Diesel Engines (CTM 86) for information on servicing the fuel injection system.

Have an authorized diesel repair station perform any internal service or test stand calibration required on injection pumps.

See Section 1100, Engine, for more information.

1. Description and Operation

1.6 Fuel Shutoff Solenoid

The fuel shut-off solenoid is mounted on a bracket on the oil filter assembly on the right hand side of the engine.

The solenoid will shut off fuel to the injection pump when the ignition switch is turned off.

The connector can be disconnected during servicing procedures to prevent accidental starting of the engine.

See Section 3000, Electrical, and Section 3312, Monitor, for more information.

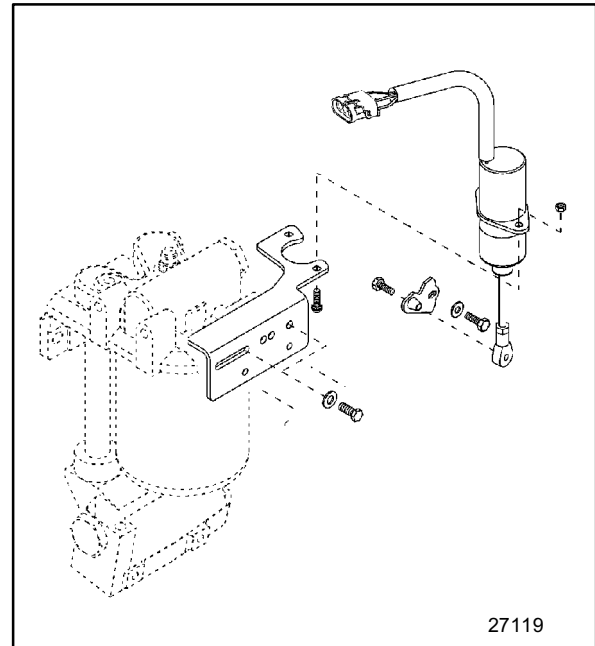

2. Checking the Fuel Level

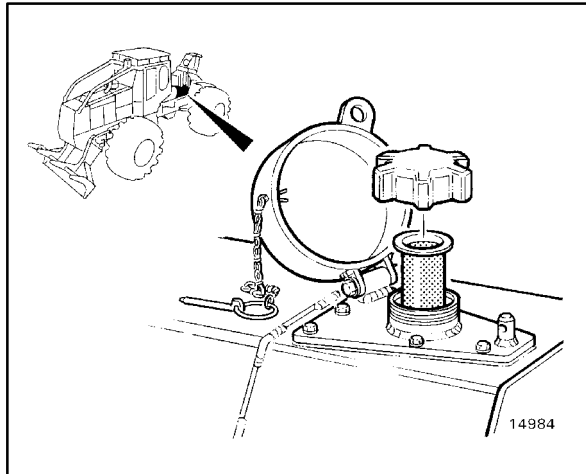

CAUTION

Never fill the fuel tank with the engine running, while you, or anyone nearby is smoking or when near an open flame.

Always stop engine before refueling machine.
Fill fuel tank outdoors.

Avoid overfilling the tank or spilling fuel. If fuel is spilled, clean it up immediately.

Fill the tank at the end of each day. This helps prevent condensation forming in an empty tank overnight.

See Section 9800, General Machine Specifications, Fluids and Lubricants, for recommended fuel.

The fuel level is displayed on the instrument panel.

Before filling, check the inlet screen for debris or dirt. Remove and clean the inlet screen if necessary.

3. Draining Water from Fuel Tank

Remove the access plug in the rear frame and pull the drain hose through.

Open the drain cock and drain approximately one pint (1/2 liter) of fuel from the tank into a suitable container to remove any water or sediment .

Close the drain cock, install the drain hose and replace the access plug.

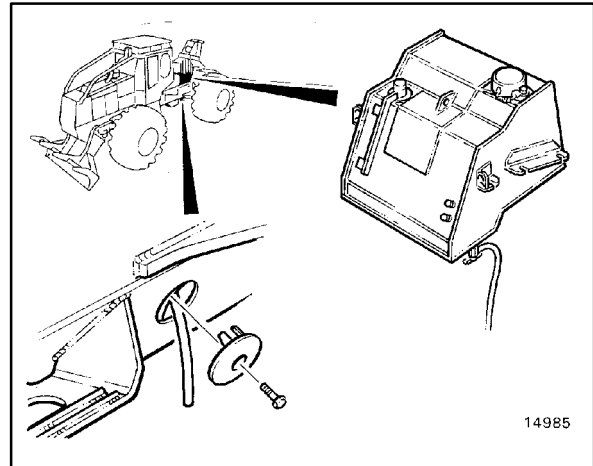

4. Filters

4.1 Checking the Primary Filter (Fuel/Water Separator)

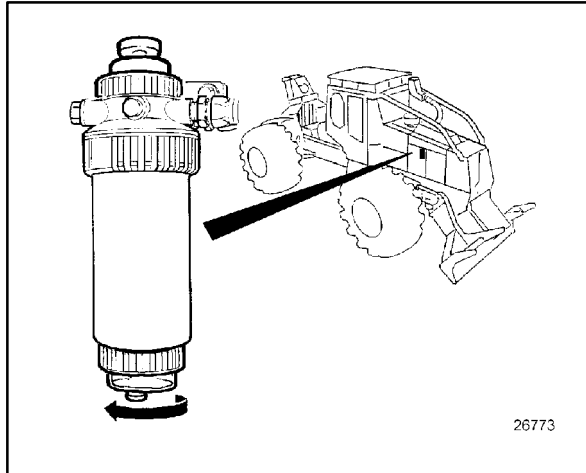

Check the glass sediment bowl of the primary fuel filter / water separator for water or debris.

Loosen the thumb screw and drain water and sediment into a suitable container.

Tighten the drain screw.

4. Filters

4.2 Replacing the Primary Filter (Fuel/water Separator)

Thoroughly clean fuel filter / water separator assembly and surrounding area.

Place container under filter drain.

Drain all fuel from filter. Dispose of waste properly.

Turn retaining ring 1/4 turn counterclockwise.
Remove ring with filter element.

Turn sediment bowl counterclockwise to remove
from filter assemble. Drain and clean separator
bowl. Dry with compressed air.

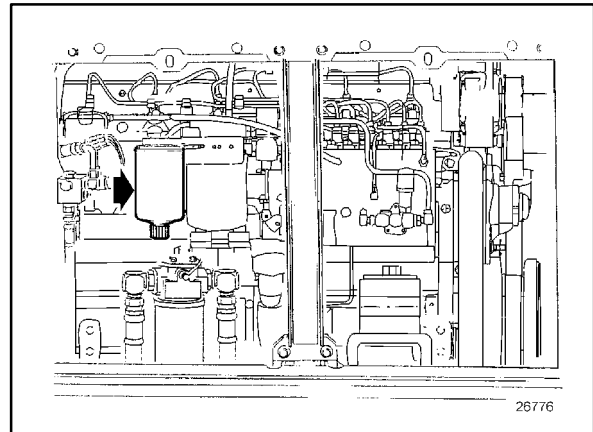

- A. Mounting Base
- B. Hand Primer
- C. Dust Seal
- D. Vertical Locators
- E. Filter Element
- F. Retaining Ring
- G. Water Separator Bowl

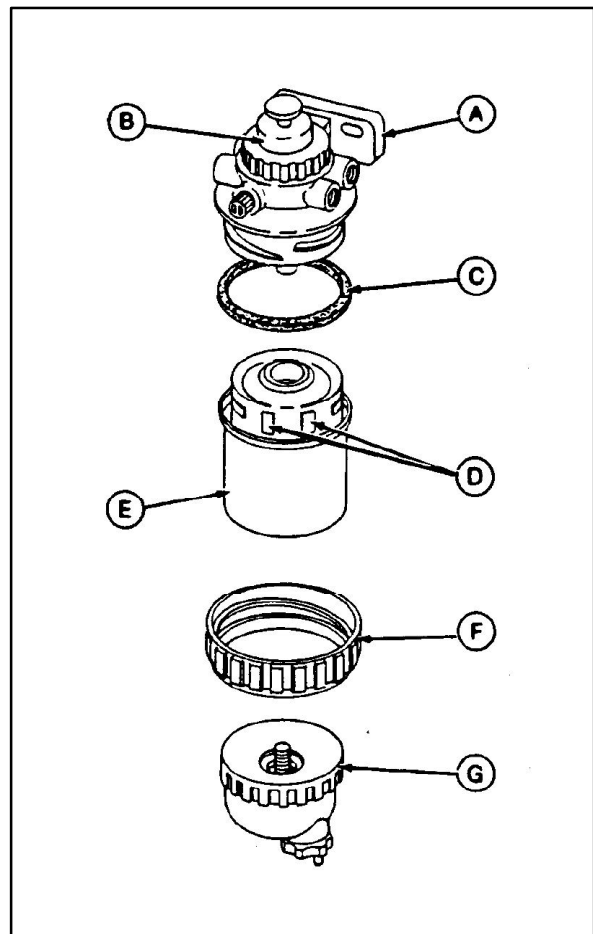

4. Filters

4.2 Replacing the Primary Filter (Fuel/water Separator)

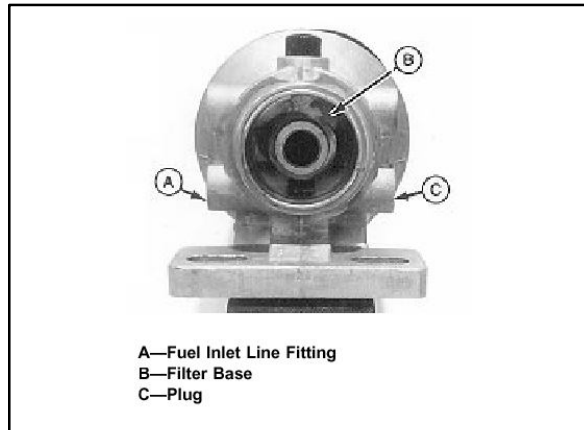

Remove hand primer from fuel filter base.
Disassemble hand primer assembly (D - I) and clean.

- A. Fuel Inlet Line Fitting
- B. Filter Base
- C. Plug
- D. Retaining Ring
- E. Pump Knob
- F. Spring Cover
- G. Spring Seat
- H. Spring
- I. Diaphragm

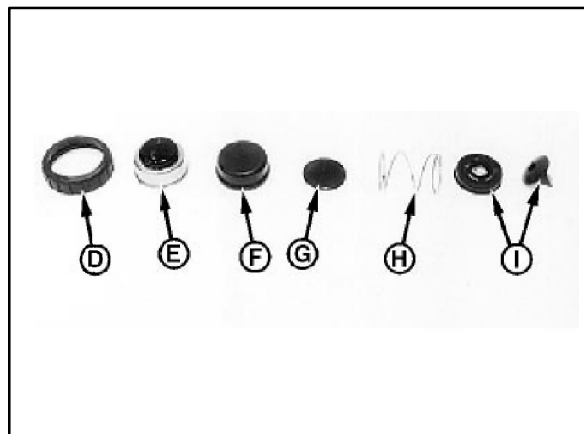

Remove fuel inlet line from fitting (A) and remove plug (C). Flush any debris from filter base (B).

Install fuel inlet plug and fuel inlet line.

Assemble fuel primer assembly and install onto fuel filter base.

Install water separator bowl onto new filter element. Tighten securely.

Install new filter element onto mounting base. It may be necessary to rotate filter for correct alignment.

NOTE: Notice raised vertical locators on the filter element. These locators ensure proper alignment of filter to filter base.

Install retaining ring to filter base, making certain that dust seal is in place on filter base. Tighten retaining ring until it locks into detent position and a 'click' sound is heard.

Bleed the fuel system.

4. Filters

4.3 Replacing Final Fuel Filter

Keep a small container under the filter drain plug to catch draining fuel.

Loosen bleed plug (C) on side of filter base. Remove drain plug (B) to drain fuel from fuel filter. Dispose of waste properly.

With fuel filter firm against base, lift up on top retaining spring and pull down on bottom retaining spring. Pull fuel filter off guide pins (A) of fuel filter base and discard.

Install new fuel filter onto guide pins of fuel filter base. Hold filter firmly against the base.

Secure bottom filter retaining spring (D) first, then secure top retaining spring.

Install new drain plug (B). Tighten drain plug and bleed plug securely. Do not overtighten.

Bleed the fuel system.

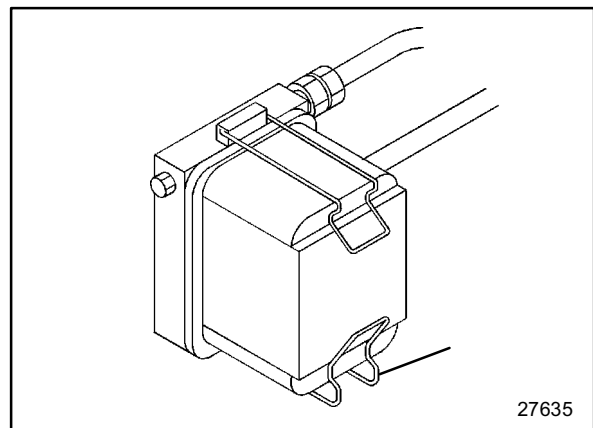
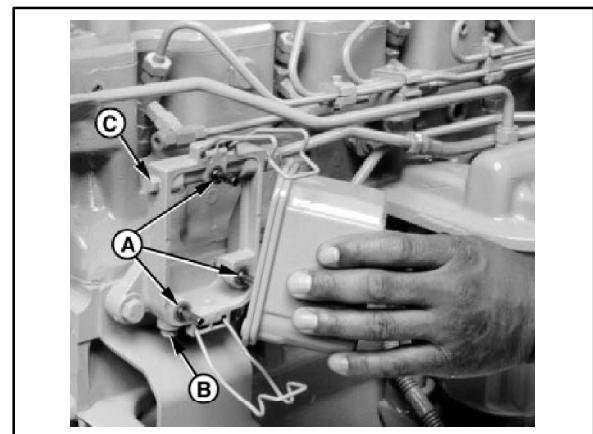
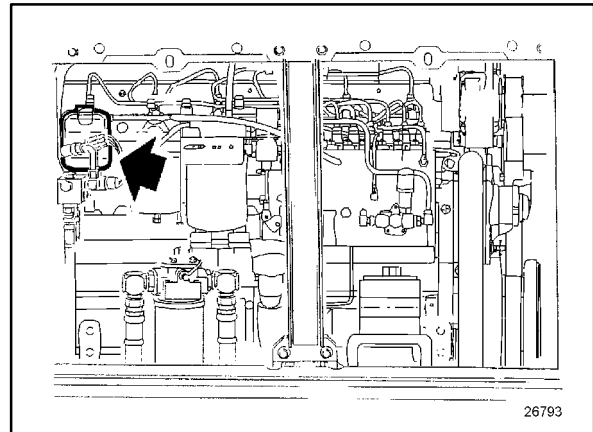

4. Filters

4.4 Replace Final Fuel Filter Check Valve

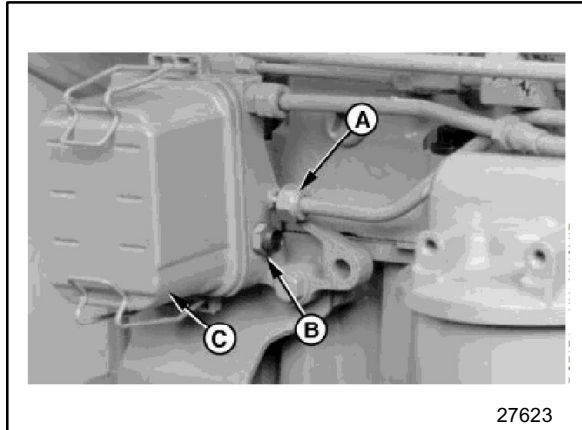

Drain and remove fuel filter (C).

Remove fuel filter inlet line (A).

Inspect and clean fuel filter base (if needed).

Remove check valve assembly (B) from fuel filter base and discard.

Install new check valve assembly and tighten securely.

Install fuel inlet line and tighten connection to 17 Nm (12 lb-ft) maximum. DO NOT overtighten.

Install fuel filter and bleed fuel system.



Suggest:

If the above button click is invalid.

Please download this document

first, and then click the above link

to download the complete manual.

Thank you so much for reading

5. Bleeding the Fuel System



CAUTION

Escaping fluid under pressure can penetrate the skin causing serious injury. Avoid the hazard by relieving pressure before disconnecting hydraulic or other lines. Tighten all connections before applying pressure. Search for leaks with a piece of cardboard. Protect hands and body from high pressure fluids.

If an accident occurs, see a doctor immediately. Any fluid injected into the skin must be surgically removed within a few hours or gangrene may result. Doctors unfamiliar with this type of injury should reference a knowledgeable medical source.

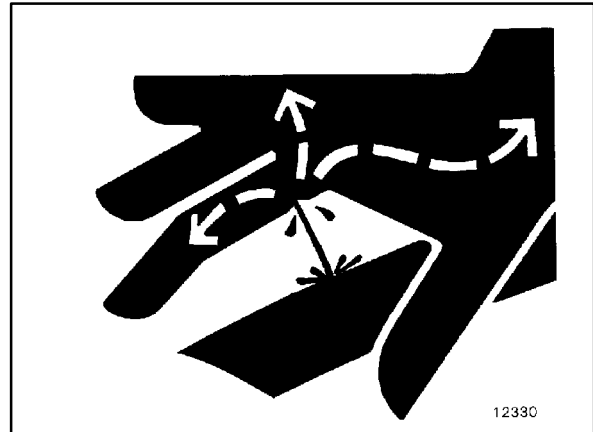

Whenever the fuel system has been opened up for service, it will be necessary to bleed air from the system.

5. Bleeding the Fuel System

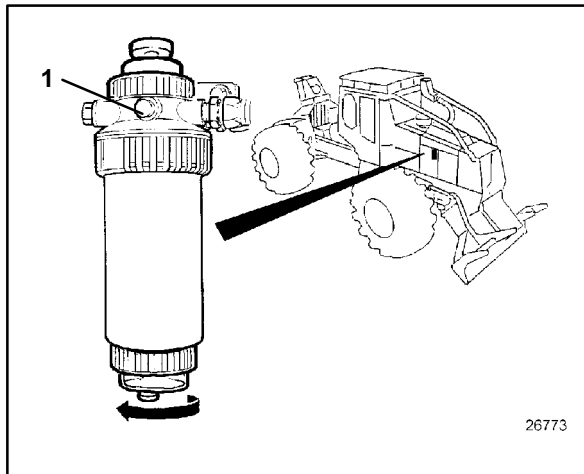

At Primary Fuel Filter (Fuel/water Separator):

Drain water and sediments from clear sediment bowl.

Loosen air bleed vent screw (1) on fuel filter base.

Operate hand primer (2) until fuel free from air bubbles flows from air bleed vent hole.

Tighten vent screw as hand primer is held down.

To continue, bleed air at final filter.

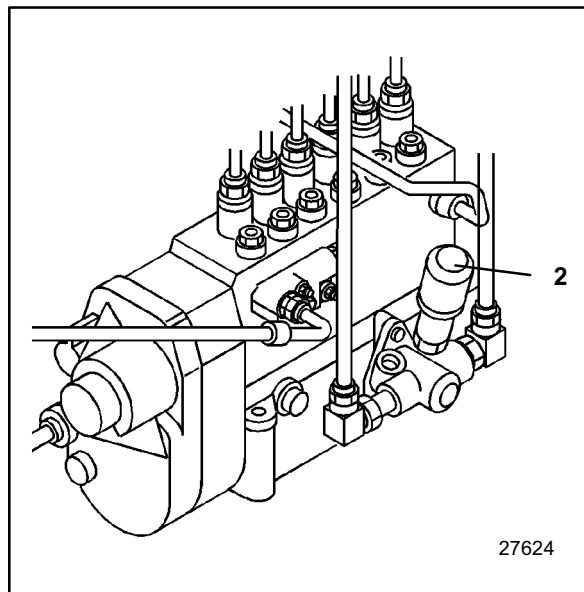

5. Bleeding the Fuel System

At rectangular Final Fuel Filter:

Check filter drain screw to be sure it is tight.

Turn key switch to ON position.

Loosen bleed screw (1).

Operate hand primer (2) until fuel free from air bubbles flows from air bleed vent hole.

Tighten vent screw as hand primer is held down.
DO NOT overtighten.

Start engine and check for leaks.

If engine will not start, it may be necessary to bleed air from fuel system at fuel injection nozzles.

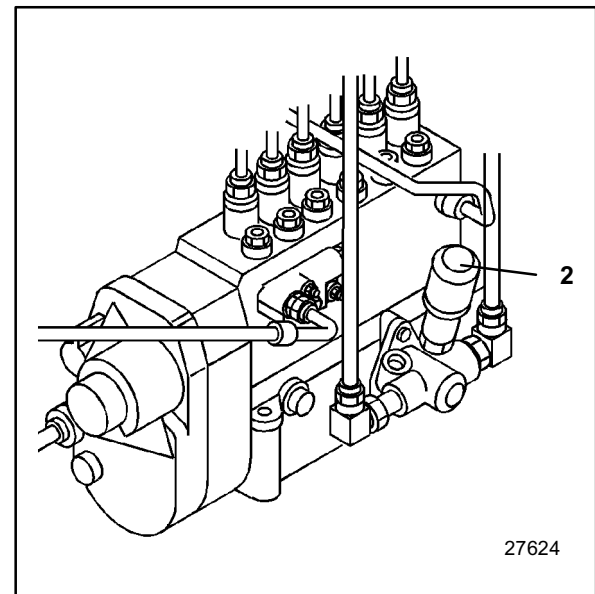
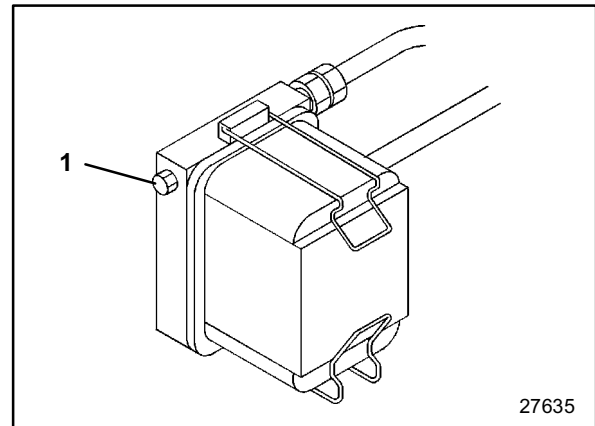

<https://www.ebooklibonline.com>

Hello dear friend!

Thank you very much for reading.

Enter the link into your browser.

The full manual is available for immediate download.

<https://www.ebooklibonline.com>