

# 720 Series Diesel Tractor



## SERVICE MANUAL 720 Series Diesel Tractor

SM2020 01DEC57 English

**John Deere Waterloo Works**  
**SM2020 01DEC57**

LITHO IN U.S.A.  
ENGLISH



**SERVICE MANUAL FOR  
JOHN DEERE DEALERS**

**720<sup>0</sup>  
SERIES DIESEL TRACTOR**

**TABLE OF CONTENTS**

	<b>Section</b>
Description, Operation and Specifications .....	10
Predelivery, Delivery, After-Delivery and 150-Hour Services .....	20
Tune-Up and Adjustment .....	40
Diesel Engine .....	60
Cranking Engine and Accessories .....	65
Governor and Speed-Control Linkage .....	70
Electrical System .....	80
Cooling System .....	90
Diesel Engine Lubrication System .....	100
Fuel System .....	110
Pulley, Clutch and Pulley Brake .....	120
Transmission .....	130
Powershaft .....	135
Differential and Final Drive .....	140
Float-Ride Seat .....	145
Brakes .....	150
Wheels and Tires .....	160
Steering Mechanism and Front Axle .....	170
Custom Powr-Trol .....	180



## TO THE JOHN DEERE SERVICEMAN

This Service Manual contains maintenance instructions for the John Deere "720" Series Diesel Tractor. Included are complete instructions for removal, disassembly, inspection, repair, assembly and installation of the major parts and assemblies of the tractor. In addition, the manual contains brief descriptions of the more complicated systems of the tractor, and tells how they operate. Dimensions of many new wearing parts are given as an aid in determining when parts replacement is necessary. Tests and adjustments, required to keep the tractor operating efficiently, are explained in detail.

The manual also contains complete instructions for performing the predelivery, delivery, after-delivery and 150-hour services outlined in the Service Policy which accompanies each tractor. By using this information, you will be sure that the tractor is ready to perform efficiently and economically when it is delivered to its new owner and that it will be restored to peak efficiency when it is brought into your shop for after-delivery services. A section on "Tune-Up and Adjustment" contains instructions for performing the services necessary to help the tractor perform efficiently and economically after it has been in the field for some time.

The sections in this manual concerning the power steering mechanism, fuel injection pumps and nozzles, electrical equipment and Powr-Trol

are limited mainly to removal and installation instructions. Full maintenance instructions for the power steering mechanism are given in *Service Manual SM-2016, "Power Steering for John Deere Tractors."* When additional information, concerning the fuel injection pumps and nozzles, is required, see *Service Manual SM-2018, "Testing and Servicing Fuel Injection Pumps and Nozzles."* Instructions for testing, repairing and adjusting the generator and electric cranking motor are given in *Service Manual SM-2000, "Tractors and Engines (General)."* For additional information concerning the Custom Powr-Trol mechanism, consult *Service Manual SM-2022, "Custom Powr-Trol."*

This manual is written specifically for "720" Series Diesel Tractors with Serial Numbers above 7214900. However, most of the information it contains applies equally to tractors with Serial Numbers below 7214900. Where procedures are completely different, the exceptions are noted and described. When variations are minor, the serviceman will be able to apply the information without difficulty.

This manual was planned and written for the Service Department; its place is in the shop. Use the manual whenever in doubt about correct maintenance procedures. Use it as a text book for training new Service Department personnel who are unfamiliar with John Deere Tractors.

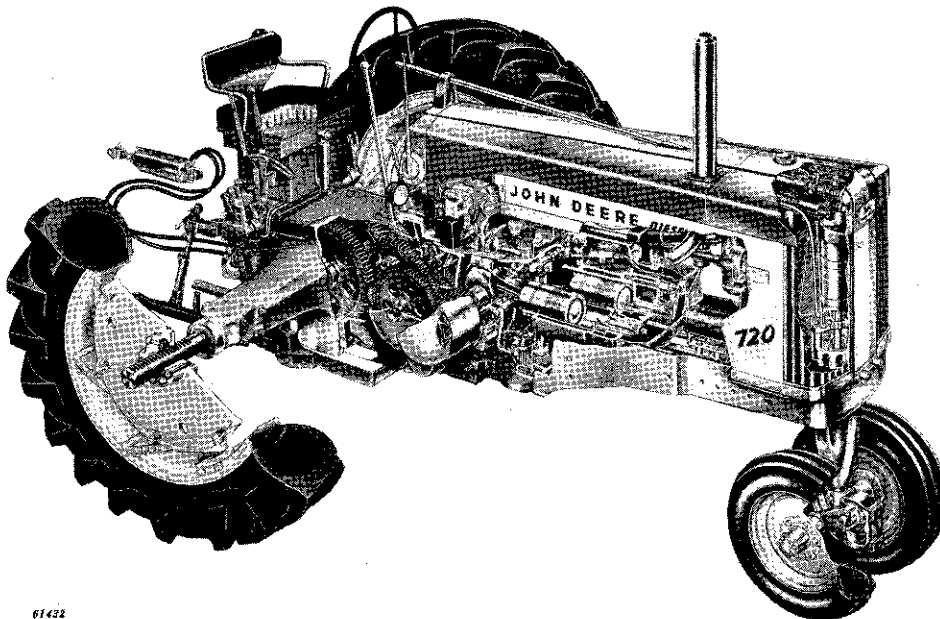

61422

*Cutaway View of John Deere "720" Series Diesel Tractor with Gasoline Cranking Engine*

**<https://www.ebooklibonline.com>**

Hello dear friend!

Thank you very much for reading.

Enter the link into your browser.

The full manual is available for immediate download.

**<https://www.ebooklibonline.com>**

# INDEX

A	Page	Page	
Accessories—Cranking Engine.....	65-5-1	Brush Tension, Generator.....	80-5-1
Adjustable-Tread Front Axle.....	170-15-1	Bushing and Bearing, Pulley.....	120-5-3
Adjustable-Tread Front End, Wide— Specifications.....	170-25-1	Bushings, Crankshaft—Cranking En- gine.....	65-5-12
Adjustment, Pressure—Fuel Transfer Pump.....	110-15-1	<b>C</b>	
Adjustment and Tune-Up.....	40-5-1	Cam Followers—Diesel Engine.....	60-25-1
After-Delivery Services.....	20-5-1	Camshaft—Cranking Engine.....	65-5-8
After-Delivery Service.....	20-15-4	Camshaft—Diesel Engine.....	60-25-1
Air, Bleeding from Fuel System.....	20-10-6, 40-10-4, 110-20-1	Camshaft—Specifications—Diesel En- gine.....	60-30-2
Air Cleaner—Cranking Engine... 40-20-4, 65-25-3		Capacities—Engine.....	10-15-1
Air Cleaner—Diesel Engine... 20-10-5, 110-35-1		Cap Screws and Nuts.....	20-15-4
Air Cleaner Oil Level—Cranking Engine 20-10-4		Cap Screw Tensions—Specifications— Diesel Engine.....	60-30-2
Air Cleaner—Temperature-Oil Weight Chart.....	20-10-6, 40-10-2	Carburetor.....	40-20-4, 65-25-3
Air Intake System—Diesel Engine.....	40-10-1	Cetane Number, Diesel Fuel.....	110-5-2
Air Pressure, Tires.....	20-10-3, 160-15-1	Changing Fuel Filter Elements.....	110-20-1
Axle, Front—Wide Adjustable-Tread... 170-15-1		Cleaner, Air—Cranking Engine... 40-20-4, 65-25-3	
Axle, Front—Specifications.....	170-25-1	Cleaner, Air—Diesel Engine... 20-10-5, 110-35-1	
Axle Housing, Rear.....	140-5-2, 140-5-6	Cleaning Fuel Tanks—Diesel Engine... 110-10-1	
<b>B</b>		Clutch.....	20-15-3, 40-15-1, 120-5-1
Backlash—Steering Gear.....	20-10-9, 40-15-4	Clutch—Cranking Engine.....	20-10-8, 40-20-1, 40-20-6, 65-20-1
Ballast.....	20-10-7, 160-15-3	Clutch—Diesel Engine.....	10-5-3, 20-10-8, 120-5-1, 120-5-6
Battery.....	20-10-4, 20-10-6, 80-10-1	Clutch Facing Replacement.....	120-5-2
Battery Registration.....	20-15-3	Clutch and Pulley Brake.....	20-10-15
Bearings, Connecting Rod—Diesel En- gine.....	60-15-1	Clutch and Pulley—Specifications.....	120-15-1
Bearings, Differential.....	140-5-3	Clutch, Powershaft.....	20-10-8, 40-15-3, 135-10-1, 135-15-1
Bearings, Final Drive.....	140-10-3	Clutch—Specifications.....	10-15-1
Bearing, Lower—Steering Spindle.....	170-5-4	Coil, Ignition—Cranking Engine.....	65-25-6
Bearings, Main—Diesel Engine.....	60-20-1	Coil Tester—Cranking Engine.....	65-25-6
Bearings, Main—Specifications—Diesel Engine.....	60-30-2	Compression Test.....	40-10-3, 40-20-1
Belt, Generator Drive.....	20-10-6	Condenser—Cranking Engine.....	65-25-6
Belt Pulley—Specifications.....	10-15-1	Connecting Rods—Cranking Engine... 65-5-10	
Bevel Gear Assembly and Drive Shaft —Powershaft.....	135-5-3	Connecting Rods—Diesel Engine.....	60-15-1
Bevel Gear and Spur Pinions, Differen- tial.....	140-5-3	Connecting Rods—Diesel Engine— Specifications.....	60-30-2
Bevel Pinions, Differential.....	140-5-4	Controls.....	20-15-2
Bleeding Air from Fuel System.....	20-10-6, 40-10-4, 110-20-1	Control Rod, Speed.....	40-10-10
Body, Oil Filter.....	100-10-2	Coolant Level in Radiator.....	20-10-3
Bowl, Sediment—Diesel Engine Fuel System.....	110-10-1	Cooling System... 10-5-3, 20-10-5, 20-15-2, 40-5-2, 40-15-6, 65-10-1, 90-5-1	
Brakes.....	10-5-3, 20-10-15, 20-15-3, 40-5-2, 40-15-5, 150-5-1	Cooling System—Specifications.....	10-15-1
Brake Adjustment.....	20-10-8, 135-10-10	Countershaft, Transmission... 130-5-1, 130-15-1	
Brake, Pulley.....	20-10-8, 20-10-15, 40-15-2, 120-5-1, 120-5-6, 120-10-1, 120-10-3	Countershaft—Specifications.....	130-20-1
Brake Shoe Assembly.....	150-5-2	Counterweights, Crankshaft.....	60-10-3
Brakes—Specifications.....	10-15-1, 150-5-3	Cover, First Reduction Gear... 60-20-8, 120-10-1	
Breaking-In Period.....	20-15-2	Cover, Rockshaft Housing.....	180-10-2
		Crankcases, Oil Level.....	20-10-3
		Crankcase, Oil Type—Cranking Engine 65-15-4	
		Crankcase Ventilation.....	20-15-2, 60-5-2
		Cranking Engine.....	10-5-2, 20-10-5, 65-5-1

**Tractor, "720" Series Diesel—  
Index**

	Page
Cranking Engine Clutch Adjustment . . . . .	20-10-8, 40-20-6
Cranking Engine— Specifications . . . . .	10-15-1, 65-30-1
Cranking Engine, Starting . . . . .	10-10-1
Cranking Engine, Stopping . . . . .	10-10-3
Cranking Engine Trouble Shooting . . . . .	65-35-1
Cranking Engine Tune-Up . . . . .	40-20-1
Cranking Motor, Electric . . . . .	65-25-1
Cranking Motor and Ignition-Light Switch . . . . .	20-10-6, 20-15-3
Crankshaft—Diesel Engine . . . . .	60-20-1
Crankshaft—Diesel Engine—Specifica- tions . . . . .	60-30-2
Crankshaft and Bushings—Cranking Engine . . . . .	65-5-12
Crankshaft Counterweights . . . . .	60-10-3
Crankshaft End Play—Diesel Engine . . . . .	60-20-6
Crankshaft End Play Adjustment . . . . .	40-10-3
Cushions, Seat . . . . .	145-5-1
Custom Powr-Trol . . . . .	20-10-16, 20-15-3, 40-5-2, 40-15-5, 180-5-1
Cylinder Block—Diesel Engine . . . . .	60-15-1
Cylinder Block—Diesel Engine—Speci- fications . . . . .	60-30-2
Cylinder Head—Diesel Engine . . . . .	60-10-1
Cylinder Sleeves—Cranking Engine . . . . .	65-5-11
Cylinder Valve Housings, Remote . . . . .	180-10-1
<b>D</b>	
Decompression Linkage Adjustment . . . . .	40-10-3
Decompression Shaft—Diesel Engine . . . . .	60-25-1
Delivery Services . . . . .	20-5-1, 20-15-1
Description, Tractor . . . . .	10-5-1
Diesel Engine . . . . .	10-5-2, 20-10-15, 60-5-1
Diesel Engine Clutch and Pulley Brake . . . . .	20-10-8
Diesel Engine, Components . . . . .	60-5-1
Diesel Engine Fuel System . . . . .	10-5-3, 110-5-1
Diesel Engine Lubrication System . . . . .	100-5-1
Diesel Engine Oil Pressure . . . . .	40-10-11
Diesel Engine Specifications . . . . .	10-15-1, 60-30-1
Diesel Engine Speeds . . . . .	40-10-10
Diesel Engine, Starting . . . . .	10-5-3, 10-10-2
Diesel Engine, Stopping . . . . .	10-10-3, 40-10-10
Diesel Engine Tune-Up . . . . .	40-10-1
Diesel Engine Water Pump . . . . .	90-15-1
Differential . . . . .	10-5-3, 140-5-1
Differential—Specifications . . . . .	140-15-1
Disks, Clutch . . . . .	120-5-5
Distributor—Cranking Engine . . . . .	40-20-2, 65-25-5
Double Wheel Front Wheels . . . . .	160-5-1
Draft Links . . . . .	180-10-3
Drawbar . . . . .	20-15-3
Drawbar Position . . . . .	20-10-9
Drive, Fan (Power Steering Tractor) . . . . .	70-15-1
Drive, Fan—Specifications . . . . .	70-20-1
Drive, Final . . . . .	140-10-1
Drive Gear and Shaft, Transmission . . . . .	130-5-1, 130-15-1
Drive Gear, Powershaft—Diesel Engine . . . . .	60-20-5
Driving Mechanism, Powershaft . . . . .	135-5-1
Drum, Brake . . . . .	150-5-2
Drum and Oil Pump, Powershaft Clutch . . . . .	135-15-1

	Page
<b>E</b>	
Electric Cranking Motor—Cranking En- gine . . . . .	65-25-1
Electrical System . . . . .	20-10-6, 40-5-2, 80-5-1
Electrical System—Specifications . . . . .	10-15-1
Electrolyte—Battery . . . . .	80-10-1
Elements, Changing Filter . . . . .	110-20-1
End Play—Crankshaft . . . . .	40-10-3
End Play—Steering Gear . . . . .	40-15-4
Engine, Cranking . . . . .	10-5-2, 20-10-5, 65-5-1
Engine, Cranking—Clutch Adjustment . . . . .	20-10-8, 40-20-6
Engine, Cranking— Specifications . . . . .	10-15-1, 65-30-1
Engine, Cranking—Starting . . . . .	10-10-1
Engine, Cranking—Stopping . . . . .	10-10-3
Engine, Cranking—Trouble Shooting . . . . .	65-35-1
Engine, Cranking—Tune-Up . . . . .	40-20-1
Engine, Diesel . . . . .	10-5-2, 20-10-15, 60-5-1
Engine, Diesel—Clutch and Pulley Brake . . . . .	20-10-8, 120-5-1
Engine, Diesel, Engine Components . . . . .	60-5-1
Engine, Diesel—Fuel System . . . . .	10-5-3, 110-5-1
Engine, Diesel—Lubrication System . . . . .	100-5-1
Engine, Diesel—Oil Pressure . . . . .	40-10-11
Engine, Diesel—Specifications . . . . .	10-15-1, 60-30-1
Engine, Diesel—Speeds . . . . .	40-10-10
Engine, Diesel—Starting . . . . .	10-5-3, 10-10-2
Engine, Diesel—Stopping . . . . .	10-10-3, 40-10-10
Engine, Diesel—Tune-Up . . . . .	40-10-1
Engine, Diesel—Water Pump . . . . .	90-15-1
Engine Knocks—Diesel Engine . . . . .	60-35-5
Engine Misses—Diesel Engine . . . . .	60-35-5
Engine Overheats—Diesel Engine . . . . .	60-35-3
Engine Runs Irregularly—Diesel Engine . . . . .	60-35-6
Engine Speeds—Cranking Engine . . . . .	40-20-5
Engines, Starting and Stopping . . . . .	20-15-2
Engine Tune-Up, Diesel . . . . .	40-10-1
Engine Uses Too Much Oil—Cranking Engine . . . . .	65-35-2
Engine Uses Too Much Oil—Diesel En- gine . . . . .	60-35-3

	Page
<b>F</b>	
Facing, Clutch—Replacement . . . . .	120-5-2
Fan Drive (Power Steering Tractor) . . . . .	70-15-1
Fan Drive—Specifications . . . . .	70-20-1
Fan Shaft (Manual Steering Tractors Only) . . . . .	40-15-2
Fan Shaft Assembly . . . . .	70-10-1
Fan Shaft—Specifications . . . . .	70-20-1
Fast Idle Speed—Diesel Engine . . . . .	40-10-10
Field Current, Generator . . . . .	80-5-1
Filters, Fuel . . . . .	110-20-1
Filter, Oil . . . . .	100-10-1
Final Drive . . . . .	140-10-1
Final Drive—Specifications . . . . .	140-15-1
First Reduction Gear Cover . . . . .	60-20-8, 120-10-1
Float Level, Carburetor . . . . .	40-20-4
Float-Ride Seat . . . . .	145-5-1
Flow Control Valve, Power Steering . . . . .	170-5-12
Flywheel—Cranking Engine . . . . .	65-20-1
Flywheel—Diesel Engine . . . . .	60-20-1
Flywheel Timing Marks . . . . .	40-10-6



Page	Page
Front Axle—Specifications . . . . .	170-25-1
Front Axle, Wide Adjustable-Tread . . . . .	170-15-1
Front End Weights . . . . .	160-15-3
Front End, Wide Adjustable-Tread— Specifications . . . . .	170-25-1
Front Wheels . . . . .	10-5-3, 20-15-3, 160-5-1
Front Wheel Bearings . . . . .	40-15-3
Front Wheels and Tires—Specifications . . . . .	10-15-2
Fuels . . . . .	20-10-4
Fuel, Engine Uses Too Much—Diesel Engine . . . . .	60-35-6
Fuel Filters . . . . .	110-20-1
Fuel Injection Nozzles . . . . .	20-10-6, 40-10-5, 60-10-2, 60-10-5, 110-30-1
Fuel Injection Pumps . . . . .	40-10-4, 110-25-1
Fuel Injection System . . . . .	20-10-6
Fuel Leaks—Diesel Engine . . . . .	60-35-2
Fuel Recommended—Diesel Engine . . . . .	110-5-1
Fuel Specifications . . . . .	110-5-1
Fuel System . . . . .	20-15-2, 40-5-2, 40-10-4, 110-5-1
Fuel System—Cranking Engine . . . . .	20-10-5, 65-25-3
Fuel System—Diesel Engine . . . . .	10-5-3, 20-10-5, 110-5-1
Fuel System—Specifications . . . . .	10-15-1
Fuel Tank, Diesel Engine . . . . .	110-10-1
Fuel Transfer Pump . . . . .	40-10-4, 110-15-1
<b>G</b>	
Gasoline Tank—Cranking Engine . . . . .	65-25-3
Gear Backlash, Steering . . . . .	20-10-9
Gear Cover, Reduction . . . . .	60-20-8, 120-10-1
Gears, Final Drive . . . . .	140-10-4
Gear Housing, Timing . . . . .	60-20-1
Gear, Powershaft Drive . . . . .	60-20-5
Gear, Pulley . . . . .	120-5-3
Gear and Shaft, Transmission Drive . . . . .	130-5-1, 130-15-1
Gear Shaft Gears, Sliding—Specifica- tions . . . . .	130-20-1
Gear Shaft, Sliding . . . . .	130-5-1, 130-15-1
Gear, Spider and Ring—Differential . . . . .	140-5-4
Gear, Steering . . . . .	40-15-4, 170-5-1
General-Purpose Tractor Lubrication Chart . . . . .	20-10-12
Generator . . . . .	20-10-15, 80-5-1
Generator Drive Belt . . . . .	20-10-6
Generator Specifications . . . . .	80-5-1
Governor Case . . . . .	70-10-1
Governor, Cranking Engine . . . . .	65-5-8
Governor Lever Adjustment . . . . .	40-10-9
Governor Shaft Assembly . . . . .	70-5-1
Governor, Specifications . . . . .	70-20-1
Guides, Valve—Diesel Engine . . . . .	60-10-2
<b>H</b>	
Head, Oil Filter . . . . .	100-10-2
Heat Exchanger . . . . .	10-5-3, 110-35-1
Hitch, 3-Point . . . . .	20-10-4, 40-5-2, 180-5-1
Housing Cover, Rockshaft . . . . .	180-10-2
Housing and Pivot Bracket Assembly, Front Axle . . . . .	170-15-2
Housing, Rockshaft . . . . .	180-10-3
Hydraulic System . . . . .	10-5-4, 20-10-16, 180-5-1
<b>I</b>	
Idle Adjustment—Cranking Engine . . . . .	40-20-5
Ignition-Light and Cranking Motor Switch . . . . .	20-10-6, 20-15-3
Ignition System . . . . .	20-10-7, 20-15-3
Ignition System—Cranking Engine— Specifications . . . . .	10-15-1
Inflation Chart, Tires . . . . .	20-10-3, 160-15-1
Injection Nozzles, Fuel . . . . .	40-10-5, 60-10-5, 110-30-1
Injection Nozzle Sleeves . . . . .	60-10-2
Injection Pumps, Fuel . . . . .	40-10-4, 110-25-1
Injection Pump Timing . . . . .	40-10-5
Injection Pump Timing Marks . . . . .	40-10-7
Injection System . . . . .	20-10-6
<b>K</b>	
Knee Assemblies . . . . .	170-15-2, 170-15-5
Knuckle and Spindle Assemblies . . . . .	170-15-4
<b>L</b>	
Lack of Power—Cranking Engine . . . . .	65-35-1
Leakage, Oil and Water . . . . .	40-5-1
Leaks, Fuel Tank—Diesel Engine Fuel System . . . . .	110-10-1
Leaks, Testing for—Radiator . . . . .	90-10-1
Lever Adjustment, Governor . . . . .	40-10-9
Lift Link . . . . .	180-10-3
Light-Ignition and Cranking Motor Switch . . . . .	20-15-3
Lights . . . . .	80-10-1
Light Switch . . . . .	20-10-6
Lines, Oil—Diesel Engine . . . . .	100-10-1
Links, Draft . . . . .	180-10-3
Link, Lift . . . . .	180-10-3
Link, Upper . . . . .	180-10-3
Linkage Adjustment, Decompression . . . . .	40-10-3
Linkage, Throttle—Cranking Engine . . . . .	40-20-4
Liquid Weight, Tires . . . . .	160-15-2, 160-15-3
Load Adjustment—Cranking Engine . . . . .	40-20-5
Load-and-Depth Control . . . . .	20-10-16, 180-5-1
Lubrication . . . . .	20-10-9, 20-15-2
Lubrication Chart (General-Purpose Tractor) . . . . .	20-10-12
Lubrication Chart (Standard Tractor) . . . . .	20-10-13
Lubrication Chart (3-Point Hitch) . . . . .	20-10-14
Lubrication—Diesel Engine . . . . .	60-5-2
Lubrication—Manual Steering . . . . .	170-5-9
Lubrication—Power Steering . . . . .	170-5-9
Lubrication System—Cranking Engine . . . . .	65-15-1
Lubrication System—Diesel Engine . . . . .	100-5-1
Lubrication System—Specifications . . . . .	10-15-1
Lubrication, Transmission . . . . .	130-5-5
<b>M</b>	
Main Bearings—Diesel Engine . . . . .	60-20-1
Manual Steering . . . . .	170-5-1
Manual Steering—Lubrication . . . . .	170-5-9
Mechanism, Shifter . . . . .	130-10-1, 180-5-3
Mechanism, Shifter—Specifications . . . . .	130-20-1



	Page		Page
<b>N</b>			
Nozzles, Fuel Injection.....	20-10-6, 40-10-5, 60-10-2, 60-10-5, 110-30-1		
<b>O</b>			
Oil, Engine Uses Too Much—Cranking Engine.....	65-35-2	Power, Lack of—Diesel Engine.....	60-35-1
Oil, Engine Uses Too Much—Diesel Engine.....	60-35-3	Power Steering.....	170-5-2
Oil Filter.....	100-10-1	Powershaft.....	130-5-5, 135-5-1
Oil Filter Body and Head.....	100-10-2	Powershaft Brake Adjustment.....	135-10-10
Oil Level, Air Cleaner—Cranking Engine.....	20-10-5	Powershaft Clutch.....	40-15-3, 135-10-1, 135-15-1
Oil Level in Crankcases.....	20-10-3	Powershaft Drive Gear.....	60-20-5
Oil Lines—Diesel Engine.....	100-10-1	Powershaft Driving Mechanism.....	135-5-1
Oil Pressure.....	20-10-15	Powershaft End Play Adjustment.....	135-10-9
Oil Pressure—Cranking Engine.....	40-20-5, 65-15-3	Powershaft Shifting Mechanism.....	135-5-1
Oil Pressure, Diesel Engine.....	40-10-11, 60-35-4	Power Steering—Lubrication.....	170-5-9
Oil Pressure Regulator—Diesel Engine.....	100-10-1	Power Steering Operating Adjustments.....	170-5-10
Oil Pressure Relief Valve—Diesel Engine.....	100-10-3	Power Take-Off Clutch Adjustment.....	20-10-8
Oil Pump—Cranking Engine.....	65-15-1	Power Take-Off Shaft.....	10-5-4, 20-10-19
Oil Pump—Diesel Engine.....	100-5-1	Power Take-Off Shaft—Specifications.....	10-15-2
Oil Pump Specifications—Diesel Engine.....	100-15-1	Powr-Trol Hydraulic System.....	20-10-16, 20-15-3, 180-5-1
Oil Pump and Drum, Powershaft Clutch.....	135-15-1	Powr-Trol Mechanism.....	40-5-2, 40-15-5
Oil and Water Leakage.....	40-5-1	Powr-Trol Pump.....	180-5-2
Oil Weight-Temperature Chart.....	20-10-4, 20-10-11	Powr-Trol Pump Engagement.....	20-10-8
Oil Weight-Temperature Chart—Cranking Engine.....	65-15-4	Powr-Trol Rockshaft.....	180-10-1
Oil Weight-Temperature Chart—Diesel Engine Air Cleaner.....	20-10-6, 40-10-2, 110-35-2	Powr-Trol Temperature-Oil Weight Chart.....	180-5-4
Oil Weight-Temperature Chart—Powr-Trol.....	180-5-4	Predelivery Services.....	20-5-1, 20-10-1
Oil Weight-Temperature Chart—Transmission.....	130-5-6	Pressure Adjustment, Fuel Transfer Pump.....	110-15-1
150-Hour Services.....	20-5-1, 20-10-2	Pressure, Oil—Cranking Engine.....	40-20-5, 65-15-3
Operating Pin, Brake Pulley.....	120-10-2	Pressure, Oil—Diesel Engine.....	40-10-11, 60-35-4
Operating Sleeve, Pulley.....	120-5-3	Pressure, Tires.....	20-10-3, 160-15-1
Operating Temperature, Low—Diesel Engine.....	60-35-2	Pulley, Belt.....	120-5-1
Operation—Diesel Engine.....	60-5-2	Pulley, Belt—Specifications.....	10-15-1
Operation, Tractor.....	20-15-4	Pulley Brake.....	20-10-8, 40-15-2, 120-5-1, 120-5-6, 120-10-1, 120-10-3
Operation, Transmission.....	135-5-2	Pulley Brake and Clutch.....	20-10-15
Operator's Manual.....	20-15-4	Pulley Brake—Specifications.....	120-15-1
Output—Generator.....	80-5-1	Pulley Bushing and Bearing.....	120-5-3
Overheated Engine—Diesel Engine.....	60-35-3	Pulley Casting.....	120-5-3
Overinflation of Tires, Effects of.....	160-15-2	Pulley and Clutch—Specifications.....	120-15-1
<b>P</b>			
Pedestal—Steering Spindle.....	170-5-4, 170-5-6	Pulley Gear.....	120-5-3
Performance—Specifications.....	10-15-1	Pump—Cranking Engine Cooling System.....	65-10-1
Pinion and Rack Adjustment—Rear Wheels.....	160-10-2	Pump Engagement, Powr-Trol.....	20-10-8
Pipes, Air Cleaner—Diesel Engine.....	110-35-1	Pumps, Fuel Injection.....	40-10-4, 110-25-1
Pistons—Cranking Engine.....	65-5-10	Pump, Oil—Diesel Engine.....	100-5-1
Pistons—Diesel Engine.....	60-15-1, 60-15-3	Pump, Powr-Trol.....	180-5-2
Pistons—Diesel Engine—Specifications.....	60-30-1, 60-30-2	Pump Timing, Injection.....	40-10-5
Pivot Bracket Assembly, Front Axle.....	170-15-2	Pump Timing Marks, Injection.....	40-10-7
Plugs, Spark—Cranking Engine.....	65-25-5	Pump Timing and Rack Setting, Injection.....	20-10-6
Position-Responsive Rockshaft.....	180-5-1	Pump, Transfer.....	40-10-4, 110-15-1
Power Adjusted Rear Wheels.....	160-10-3	Pump, Oil—Cranking Engine.....	65-5-1
Power, Lack of—Cranking Engine.....	65-35-1	Pump, Water—Cranking Engine.....	65-10-1
		Pump, Water—Diesel Engine.....	90-15-1
<b>Q</b>			
		Quadrant, Transmission.....	130-10-1
<b>R</b>			
		Rack Adjustment—Rear Wheels.....	160-10-2
		Rack Setting, Fuel Pump.....	20-10-6
		Radiator.....	90-10-1
		Radiator, Check Coolant Level in.....	20-10-3
		Rear Axle Housing.....	140-5-2, 140-5-6
		Rear Axles—Specifications.....	10-15-2

	Page		Page
Rear Wheels	10-5-4, 160-10-1	Specifications—Final Drive	140-15-1
Rear Wheel Bearings	40-15-4	Specifications—Front Axle	170-25-1
Rear Wheels and Tires—Specifications	10-15-2	Specifications, Fuel	110-5-1
Reduction Gear Cover	60-20-8, 120-10-1	Specifications—Fuel System	10-15-1
Regulator, Oil Pressure—Diesel Engine	100-10-1	Specifications—Generator	80-5-1
Regulator, Voltage	80-5-1	Specifications—Governor	70-20-1
Relief Valve—Cranking Engine Lubrication System	65-15-3	Specifications—Ignition System (Cranking Engine)	10-15-1
Relief Valve, Oil Pressure—Diesel Engine	100-10-3	Specifications—Lubrication System	10-15-1
Relief Valve, Power Steering	170-5-12	Specifications—Oil Pump	100-15-1
Remote Cylinders	20-10-17	Specifications—Pulley and Clutch	120-15-1
Remote Cylinder Valve Housings	180-10-1	Specifications—Roll-O-Matic	170-25-1
Rim Clamp Nuts, Rear Wheels	20-10-7	Specifications—Steering Mechanism	170-25-1
Rings, Piston—Diesel Engine	60-15-1	Specifications—Transmission	130-20-1
Rockshaft	20-10-16	Specifications—Voltage Regulator	80-5-1
Rockshaft Housing	180-10-3	Specifications, Wheel Spindles	170-10-3
Rockshaft Housing Cover	180-10-2	Specific Gravity—Battery	80-10-1
Rockshaft, Position-Responsive	180-5-1	Speed Control Rod, Adjustment of	40-10-10
Rockshaft, Powr-Trol	180-10-1	Speeds, Cranking Engine	40-20-5
Rods, Connecting—Cranking Engine	65-5-10	Speeds, Diesel Engine	40-10-10
Roll-O-Matic Front Wheels	160-5-1, 170-10-1	Speeds, Engine	10-15-1
Roll-O-Matic—Specifications	170-25-1	Spider and Ring Gear, Differential	140-5-4
Rubber Tire Inflation Chart	20-10-3, 160-15-1	Spindle and Knuckle Assemblies	170-15-4
<b>S</b>			
Safety in Operation	20-15-4	Spindle, Steering	170-5-4, 170-5-6, 170-5-8
Seals, Final Drive	140-10-3	Spindles, Wheel—Specifications	170-10-3
Seat	20-10-9	Spur Pinions, Differential	140-5-3
Seat Cushions	145-5-1	Standard Tractor Lubrication Chart	20-10-13
Seat, Float-Ride	145-5-1	Starting the Engines	10-10-1, 20-15-2
Sediment Bowl, Diesel Engine Fuel System	110-10-1	Starting Difficulties—Cranking Engine	65-35-1
Service Policy	20-5-1, 20-10-1, 20-15-1, 20-15-4	Starting Difficulties—Diesel Engine	60-35-3
Servicing Valves—Cranking Engine	65-5-6	Starting Mechanism—Diesel Engine	10-5-3
Shaft Assembly, Fan	70-10-1	Starting Motor—Cranking Engine	65-25-1
Shaft Assembly, Governor	70-5-1	Steering Gear	40-15-4
Shaft, Drive Gear, Transmission	130-5-1, 130-15-1	Steering Gear Backlash	20-10-9
Shaft, Fan—Specifications	70-20-1	Steering, Manual	170-5-1
Shaft Gears, Sliding Gear—Specifications	130-20-1	Steering Mechanism	10-5-3, 20-10-15, 40-5-2, 170-5-1
Shaft, Sliding Gear	130-5-1, 130-15-1	Steering Mechanism—Specifications	170-25-1
Shifter Mechanism	130-10-1, 180-5-3	Steering, Power	170-5-2, 170-5-10
Shifter Mechanism—Specifications	130-20-1	Steering, Power—Operating Adjustments	170-5-10
Shifter Shafts, Transmission	130-10-1, 130-10-6	Steering Valve	170-5-11
Shifters, Transmission	130-10-1	Stopping the Cranking Engine	10-10-3
Shifting Mechanism, Powershaft	135-5-1	Stopping the Diesel Engine	10-10-3, 40-10-10
Signatures	20-15-4	Stopping the Engines	10-10-1, 20-15-2
Single Front Wheel	160-5-3	Stud Nut Tensions—Diesel Engine	60-30-2
Sleeve, Clutch Operating	120-5-3	<b>T</b>	
Sleeves, Injection Nozzle	60-10-2	Tank, Fuel—Cranking Engine	65-25-3
Sliding Gear Shaft	130-5-1, 130-15-1	Tank, Fuel—Diesel Engine	110-10-1
Sliding Gear Shaft Gears—Specifications	130-20-1	Tappet Adjustment—Cranking Engine	40-20-3
Slow Idle Speed—Diesel Engine	40-10-10	Tappet Adjustment—Diesel Engine	60-10-5
Spark Plugs—Cranking Engine	40-20-2, 65-25-5	Tappet Lever Assembly—Diesel Engine	60-10-4
Specifications—Brakes	150-5-3	Tappet Lever Clearance Adjustment—Diesel Engine	40-10-2
Specifications—Clutch and Pulley	120-15-1	Tappet Levers and Shaft—Specifications—Diesel Engine	60-30-1
Specifications—Cooling System	10-15-1	Temperature Chart—Thermostat	90-10-4
Specifications—Cranking Engine	65-30-1	Temperature, Low Operating—Diesel Engine	60-35-2
Specifications—Differential	140-15-1	Temperature-Oil Weight Chart	20-10-4, 20-10-11
Specifications—Electrical System	10-15-1	Temperature-Oil Weight Chart—Cranking Engine	65-15-4



**Tractor, "720" Series Diesel—  
Index**

	Page
Temperature-Oil Weight Chart—Diesel Engine Air Cleaner . . . . .	20-10-6, 40-10-2, 110-35-2
Temperature-Oil Weight Chart—Powr-Trol . . . . .	180-5-4
Temperature-Oil Weight Chart—Transmission . . . . .	130-5-6
Tester—Thermostat . . . . .	90-10-4
Thermostat—Cranking Engine . . . . .	65-10-3
Thermostat—Diesel Engine . . . . .	90-10-3
3-Point Hitch . . . . .	40-5-2, 180-5-1
3-Point Hitch Lubrication Chart . . . . .	20-10-4
Throttle Linkage—Cranking Engine . . . . .	40-20-4
Timing Distributor—Cranking Engine . . . . .	40-20-3
Timing Gear Housing . . . . .	60-20-1
Timing, Injection Pump . . . . .	20-10-6, 40-10-5
Timing Marks, Flywheel . . . . .	40-10-6
Timing Marks, Injection Pump . . . . .	40-10-7
Timing, Valve . . . . .	40-10-6
Tires . . . . .	20-10-7, 20-10-8, 20-15-2, 40-5-2, 160-15-1
Tires, Deflate to Operating Pressure . . . . .	20-10-3
Tire Inflation Chart . . . . .	20-10-3, 160-15-1
Tire Pressure, Checking . . . . .	160-15-2
Tire Sizes . . . . .	160-15-1
Tires and Wheels—Specifications . . . . .	10-15-2
Toe-In Adjustment . . . . .	170-15-6
Transfer Pump . . . . .	40-10-4, 110-15-1
Transmission . . . . .	10-5-3, 20-10-15, 130-5-1
Transmission—Cranking Engine . . . . .	65-20-1
Transmission Lubrication . . . . .	130-5-5
Transmission—Specifications . . . . .	10-15-1, 130-20-1
Tread Adjustment—Rear Wheels . . . . .	160-10-1, 160-10-4
Tread Adjustments—Specifications . . . . .	10-15-2
Trouble Shooting—Cranking Engine . . . . .	65-35-1
Trouble Shooting—Diesel Engine . . . . .	60-35-1
Tune-Up and Adjustment . . . . .	40-5-1
Tune-Up, Cranking Engine . . . . .	40-20-1
Tune-Up—Diesel Engine . . . . .	40-10-1

**U**

Underinflation of Tires, Effects of . . . . .	160-15-2
Upper Links . . . . .	180-10-3

**V**

Valves—Cranking Engine . . . . .	65-5-5
Valves—Diesel Engine . . . . .	60-10-1
Valve Assembly, Steering . . . . .	170-5-3
Valve Core and Cap, Tires . . . . .	160-15-2
Valve, Flow Control—Power Steering . . . . .	170-5-12
Valve Guides—Diesel Engine . . . . .	60-10-2
Valve Housing, Power Steering . . . . .	170-5-11
Valve Housings, Remote Cylinder . . . . .	180-10-1
Valve, Power Steering . . . . .	170-5-11
Valve, Relief—Cranking Engine Lubrication System . . . . .	65-15-3
Valve, Relief—Diesel Engine—Oil Pressure . . . . .	100-10-3
Valve, Relief—Power Steering . . . . .	170-5-12
Valves, Servicing—Cranking Engine . . . . .	65-5-6
Valves—Specifications—Diesel Engine . . . . .	60-30-1

Valve Timing . . . . .	40-10-6
Voltage Regulator . . . . .	80-5-1
Voltage Regulator—Specifications . . . . .	80-5-1

**W**

Warm-Up Period . . . . .	10-10-3
Water and Oil Leakage . . . . .	40-5-1
Water Pump—Cranking Engine . . . . .	65-10-1
Water Pump—Diesel Engine . . . . .	90-15-1
Weights, Front End . . . . .	160-15-3
Weights, Wheel . . . . .	160-15-2
Wheels . . . . .	20-10-7, 160-5-1
Wheels, Front . . . . .	10-5-3, 20-15-3, 40-15-3, 40-15-4, 160-5-1
Wheel Hub Cap Screws and Rim Clamp Nuts . . . . .	20-10-7
Wheel Spindles—Specifications . . . . .	170-10-3
Wheels, Rear . . . . .	10-5-4, 160-10-1
Wheels and Tires—Specifications . . . . .	10-15-2
Wheel Weights . . . . .	160-15-2
Wide Adjustable-Tread Front End— Specifications . . . . .	170-25-1
Wide Adjustable-Tread Front Wheels . . . . .	160-5-1
Wiring Diagram . . . . .	80-10-2
Worm Assembly, Steering . . . . .	170-5-4, 170-5-8



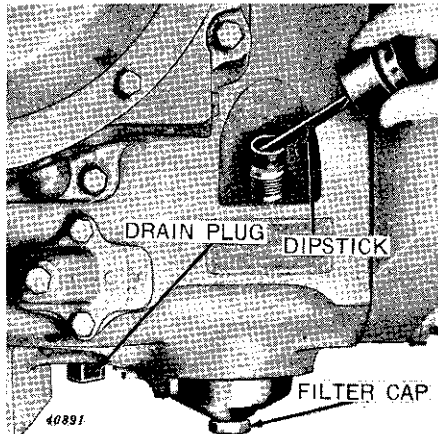

Figure 20-10-3—Diesel Engine Crankcase Dip Stick

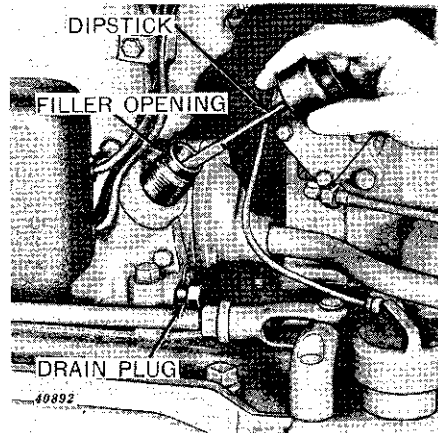

Figure 20-10-4—Cranking Engine Crankcase Dip Stick, Filler Opening, and Drain Plug

Figure 20-10-5 shows the location of the Diesel engine crankcase filler opening.

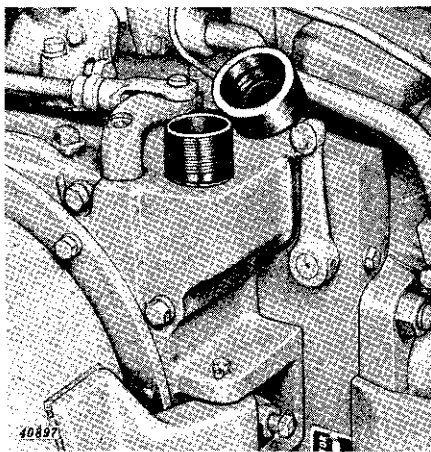

Figure 20-10-5—Diesel Engine Crankcase Filler Opening

The chart below shows weight of oil to use in both engines, depending on prevailing temperatures.

### TEMPERATURE-OIL WEIGHT CHART FOR DIESEL ENGINE AND CRANKING ENGINE

Air Temperature	Weight of Oil to Use	
	Single-Viscosity Oil	Multi-Viscosity Oil
Above 90° F.	SAE 20-20W	SAE 10W-30
0 to 90° F.	SAE 10W*	SAE 10W-30
Below 30° F.	SAE 5W	SAE 5W-20

**CAUTION:** Use of SAE 5W motor oil will likely result in some increase in oil consumption. Advise operator to check oil level more frequently when using this oil. Do not use SAE 5W oil except during the extremely cold weather conditions specified above.

\*In areas where SAE 10W is not readily available, SAE 20-20W oil can be used above 32° F.

### Put Fuel in Tanks.

Fill the cranking engine tank with regular gasoline having a minimum octane rating of 80 (Motor Method) or 86 (Research Method). Capacity of the tank is 1 U.S. quart.

Use either No. 1-D or No. 2-D Diesel fuel, as defined by ASTM designation D-975-53-T for Diesel fuels, in the Diesel engine tank. General specifications for these fuels are given on page 10-20-1. Capacity of the fuel tank is 20 U.S. gallons.

### Battery (For immediate delivery).

Install electrolyte if the tractor is equipped with a dry-charge battery. Connect battery.

When tractor is to be stored, use a slave battery to move tractor.

During the Predelivery Service the tractor can now be unloaded.

## 2. COOLING SYSTEM.

In cold weather use a hydrometer to check the strength of the anti-freeze solution in the cooling system. Adjust solution strength to anticipated temperatures.

Check for leaks at all connections.

If coolant is changed, add sealer, rust inhibitor and water pump lubricant. Capacity of cooling system is 7 U.S. gallons. *NOTE: Never, under any circumstances, operate the tractor without water or anti-freeze solution, even for a few minutes. Never pour cold water into a heated engine. Before adding coolant, allow engine to cool off gradually since sudden contraction of metal parts may damage the engine. For the same reason, in cold, freezing weather, never drain water immediately after stopping the engine.*

## 3. FUEL SYSTEM (CRANKING ENGINE).

**Check for Leaks.**

Check fuel lines and connections for leaks (Figure 20-10-6). Make sure air cleaner connections are tight.

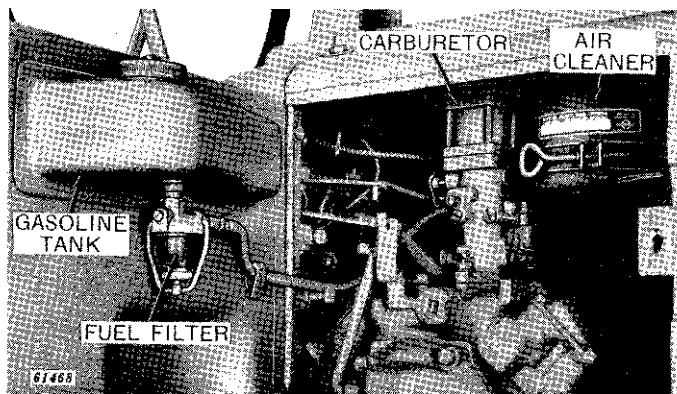

Figure 20-10-6—Cranking Engine Fuel System

### Check Air Cleaner Oil Level.

Remove air cleaner cup. Check level and condition of oil. If it is dirty, clean cup. If oil level is low or oil has been removed, fill cup to oil level mark with same type and weight of oil as is used in Diesel and cranking engine crankcases. See chart on page 20-10-4.

## 4. FUEL SYSTEM (DIESEL).

**Check for Leaks, Inspect Fuel Strainer, and Check Position of Fuel Shut-Off Valve.**

Check for leaks. Inspect fuel strainer (Figure 20-10-7). If dirt or water are present, remove and clean bowl. Check shut-off valve, located above strainer, for leaks and be sure that it is open.

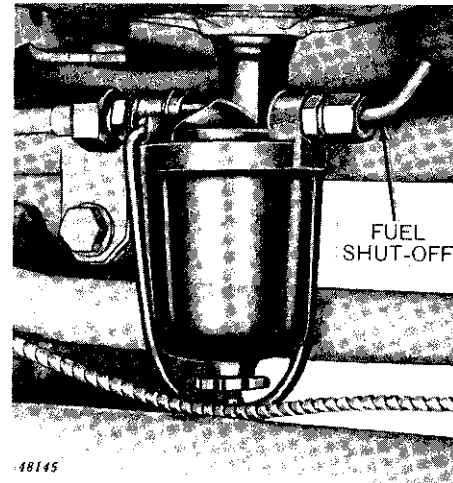

Figure 20-10-7—Diesel Engine Fuel Strainer and Shut-Off Valve

### Air Cleaner.

Remove air cleaner cup (Figure 20-10-8). Check level and condition of oil. If it is dirty, clean cup.

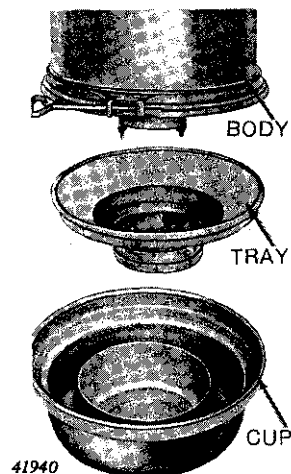

Figure 20-10-8—Air Cleaner Cup and Tray



At the 150-Hour Service, also check condition of air cleaner tray (Figure 20-10-8), and clean if necessary. Screen is clean only when daylight can be seen through it. See *Section 40 of this Manual*.

Refill air cleaner cup with oil of the proper weight, as shown in the chart below, to bring it up to the correct level. Avoid over-filling.

### DIESEL ENGINE AIR CLEANER OIL CHART

Air Temperatures	Weight of Oil to Use	
	Single- Viscosity Oil	Multi- Viscosity Oil
Above 90° F.	SAE 30	SAE 20W-40
32° to 90° F.	SAE 20-20W	SAE 10W-30
Below 32° F.	SAE 10W	SAE 5W-20

## 5. INJECTION SYSTEM.

### Check Injection Nozzles, Injection Pump Timing and Rack Setting (150-Hour Service Only).

Remove injection nozzles. Inspect them carefully, clean the tips thoroughly and check the cracking pressure as described in *Service Manual SM-2018, "Testing and Servicing Fuel Injection Pumps and Nozzles."* Correct cracking pressure is between 2400 and 2600 psi.

When reinstalling nozzles tighten the clamp nuts to 50 foot-pounds torque. Do not over-tighten or under-tighten these nuts. Over-tightening may cause the nozzle valve to stick; under-tightening permits the valve to over-heat which, in turn, may result in a sticking action of the valve assembly.

### Check Injection Pump Timing and Rack Setting (150-Hour Service Only).

Remove the flywheel cover and injection pump compartment cover and check pumps for proper timing as described in *Section 40, Group 10, of this Manual*. At the same time, check the injection pump rack setting. Under no circumstances, should the rack setting exceed 13. Unless there are definite indications that the engine is not performing properly, the rack settings should not be disturbed. When the racks are set too wide open, the usual result is excessive smoke from the exhaust and excessive fuel consumption.

## Bleed System and Check for Leaks.

Bleed the fuel system to remove any air which might be in the system. For instructions, see *Section 40, Group 10, of this Manual*.

After the above services have been performed, start the Diesel engine and check fuel lines and connections carefully for leaks. Look for presence of fuel in bottom of injection pump compartment which will indicate loose or damaged parts.

## 6. ELECTRICAL SYSTEM.

### Battery (150-Hour Service only).

Check battery electrolyte with a hydrometer (Figure 20-10-9). If electrolyte level is low, add water to bring it up to proper level. Avoid adding too much water during freezing temperatures as the engine will have to operate several hours before the water will mix thoroughly with the electrolyte. Until it is mixed there is danger of the water freezing and causing damage to the battery.

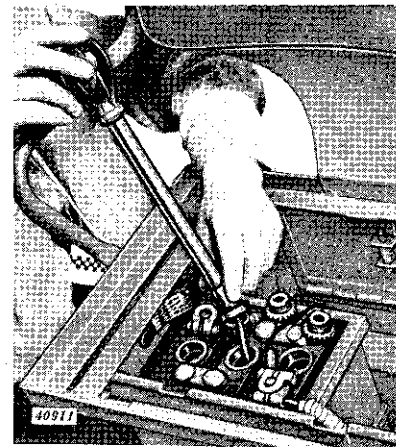

Figure 20-10-9—Checking  
Battery Specific Gravity

If the specific gravity of the battery is below 1.125 (half charge), recharge the battery. No new battery should be delivered to a customer unless it is fully charged.

### Cranking Motor and Ignition-Light Switch.

Check for proper operation of the electric cranking motor, ignition-light switch and lights. Make sure the red light under the switch comes on when the switch is turned to the "I" position.

### Generator Belt (150-Hour Service only).

Inspect the generator belt for fraying, wear or damage.

Test belt for a total of 1-inch up and down movement at the center of the belt between the pulleys. If tension is incorrect, adjust by moving

generator out or in. To do so, loosen the screw through slotted strap and the two mounting bolts (Figure 20-10-10). **CAUTION: Do not use regulator as a hand hold to move generator.**

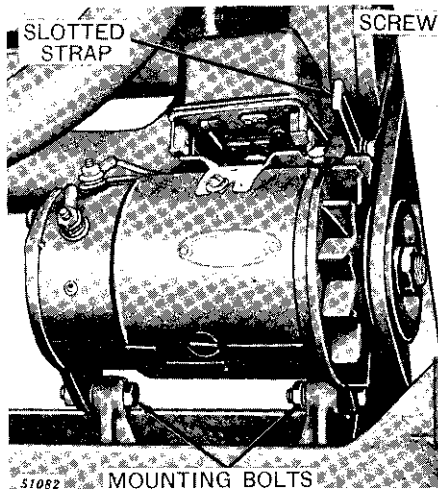

Figure 20-10-10—Generator Mounting Bolts, Adjusting Screw and Strap

## 7. IGNITION SYSTEM (150-HOUR SERVICE ONLY).

Remove and clean spark plugs. Set gap to 0.025-inch. Check distributor points for condition and set them with 0.020-inch gap. For detailed instructions, see *Section 40, Group 20, of this Manual.*

## 8. TIRES, WHEELS AND BALLAST (PREDELIVERY ONLY).

### Tires.

Carefully inspect tires for cuts, breaks or other apparent damage.

### Rear Wheel Spacing.

Check rear wheel spacing and adjust, if necessary, to customer's requirements. See *Section 160* for instructions.

### Front Wheel Spacing.

Normally the front wheels on General-Purpose tractors are spaced 2-3/8 inches apart at the bottom. If the customer so desires, this spacing can be increased to 6-1/4 inches by reversing the wheels.

The adjustable-tread front axle on a General-Purpose tractor can be adjusted from 48 to 80 inches wide (to obtain the 80-inch tread the wheels must be reversed). The adjustable-tread front axle on a Standard tractor can be adjusted from 52 to 68 inches. If possible, determine the customer's requirements and set the tread width accordingly. To adjust tread width, remove lock bolts which hold telescoping portions of axle together, and cap screws from drag link (and tie rod on Standard tractors). Jack up front of tractor and move front knees to the desired tread width. Coat all unpainted surfaces with rust preventive or heavy grease.

### Wheel Hub Cap Screws and Rim Clamp Nuts.

Tighten front wheel hub cap screws securely. Tighten rear wheel rim clamp nuts to 100 foot-pounds torque.

### Liquid and Cast-Iron Ballast.

Add liquid or cast-iron ballast to rear tires or wheels as required. Either type can be used but it will normally be found that both are needed. When liquid ballast is used, not so much cast-iron is required; therefore, a combination of both is often more practical. Ballast should **not** be added to the point where all wheel slippage is eliminated. To do so will hinder maximum performance of the engine. The ideal amount of added ballast is enough so that, when the tractor is pulling its rated load, the soil between the tire lugs is broken or shifted. When too much weight is used, the tread marks will be clear and distinct. When too little weight is used, the tread marks will be entirely obliterated.

When installing liquid ballast in climates where there is any danger of freezing, use calcium chloride solution which will not freeze.

The maximum ballast (liquid or cast-iron) per wheel is 850 pounds.

### Front End Ballast.

When some implements are being used, ballast must be added to the front end of the tractor by the addition of front end weights. It is very important that this ballast be added when needed to maintain proper stability and steering.

## 9. GENERAL.

### Tires (150-Hour Service).

When performing the 150-Hour Service, check tire inflation and adjust in accordance with chart given on page 20-10-3.

### Powr-Trol Pump Engagement.

Check to see that Powr-Trol pump engages properly. Figure 20-10-11 shows the position of the lever when the pump is engaged. Do not attempt to engage the pump with the engine running. The pump can be disengaged with the engine idling simply by turning the lever to the "OFF" position ("OFF" at top).

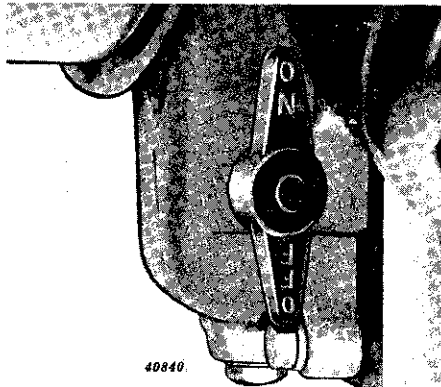

Figure 20-10-11—Powr-Trol Pump Control Lever

### Diesel Engine Clutch and Pulley Brake (150-Hour Service).

Test the clutch for proper action by engaging and disengaging it. Clutch should engage with a definite snap requiring a force of 40 to 80 pounds at end of clutch lever while the engine is running at slow idle speed.

Note action of the pulley brake. It should be adjusted so that when the clutch operating lever is moved slightly forward from the rear (or released) position the pulley is free to turn.

Instructions for adjusting the clutch and pulley brake are given in Sections 40, Group 15, and Section 120 of this Manual.

### Cranking Engine Clutch Adjustment (150-Hour Service).

Remove flywheel cover, timing hole cover and inspection hole cover. The transmission pinion should go into full mesh with the flywheel ring gear when the clutch is engaged. The clutch should not slip when engaged and the pinion should stop spinning when the clutch is disengaged. If inspection indicates that the clutch needs adjustment, refer to Section 40, Group 20, of this Manual for instructions.

### Power Take-Off Clutch Adjustment.

Proper PTO clutch adjustment is determined by measuring how far the cam disk, located inside the clutch housing, moves to the rear as the clutch is engaged. It is very important that the clutch be kept in proper adjustment, particularly while the tractor is new. Advise the operator to have it checked after the first 20 hours and first 75 hours of powershaft operation and thereafter at the end of each 150 hours of PTO operation. If at any time clutch slippage which affects powershaft output is detected, the clutch must be adjusted immediately. Full instructions for checking and adjusting the clutch are given in Section 40, Group 15, of this Manual.

### Brake Adjustment.

Apply the brakes. If either pedal travels more than 3-1/4 inches or less than 2-3/4 inches before the brake shoe contacts the drum, the brake should be adjusted. Tighten the adjusting screw up tight (Figure 40-20-15), then back it off enough to give specified pedal movement.

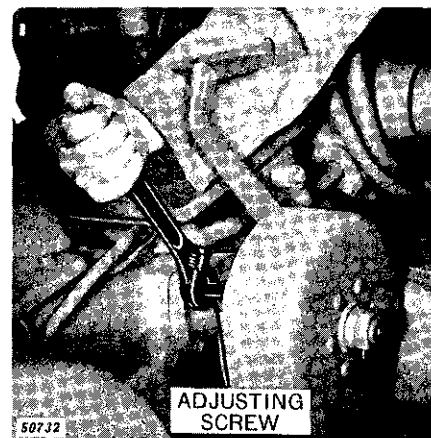

Figure 20-10-12—Adjusting Brake

### Seat.

Check seat for free movement. If it is hard to move, free it up and oil it lightly. Check "Float-Ride" seat for proper action.

### Steering Gear Backlash.

On tractors with power steering, the backlash should be from 3/8- to 3/4-inch, measured at the rim of the steering wheel. On tractors with manual steering, the measurement is 1/2- to 1-inch. If backlash is incorrect, adjust in accordance with instructions given in *Section 170 of this Manual*.

### Nuts and Cap Screws.

Tighten all accessible nuts and cap screws.

### Drawbar Position (Predelivery).

Due to variable land conditions and variable heights of hitch points on tractor-drawn implements, the drawbar hitch point may have to be raised or lowered to obtain maximum traction and fully effective steering. If possible, check with the new owner and determine the type of implement to be used and the type of work to be done, then adjust the drawbar accordingly. To raise or lower the drawbar hitch point, change the drawbar hammer strap to top or bottom of the swinging drawbar (Figure 20-10-13).

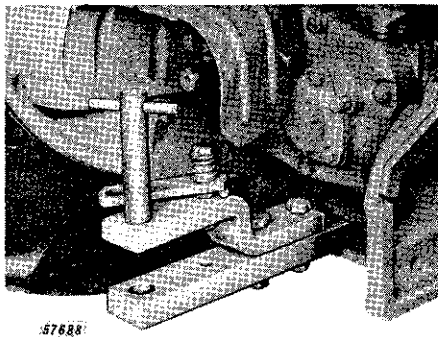

Figure 20-10-13—Drawbar with Hammer Strap on Top for High Hitch

The drawbar can also be lengthened or shortened by removing the pivot pin located at the front of the drawbar support (Figure 20-10-14) and moving the drawbar to the desired position.

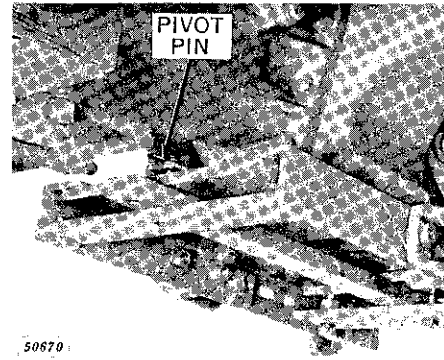

Figure 20-10-14—Drawbar Pivot Pin

When the powershaft is used, the drawbar should be set in the long position with the hammer strap on top. The hole in the end of the drawbar should be 14 inches behind the end of the powershaft (Figure 20-10-15) and the drawbar should be set in line vertically with the center of the powershaft and locked in place by tightening the drawbar locking bolts. Possible damage to the universal joints on the drawn implement will be avoided if these simple adjustments are made before the implement is attached to the tractor.

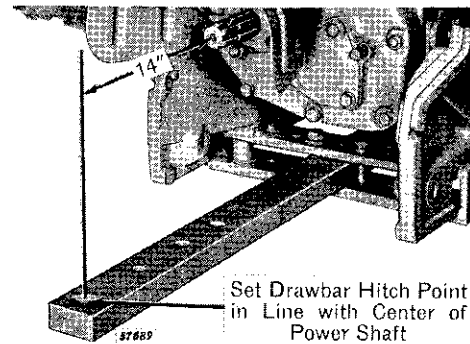

Figure 20-10-15—Drawbar Adjustment for Powershaft-Driven Implements

## 10. LUBRICATION.

Check oil level in the transmission (both Diesel engine and cranking engine), Powr-Trol, PTO clutch housing, power steering reservoir or manual steering gear housing. The illustrations on the next two pages show the dip stick or oil level plugs used to check these levels, and the filler openings. When measuring oil level on the various dip sticks, rest the caps of the dip sticks on top of the openings.

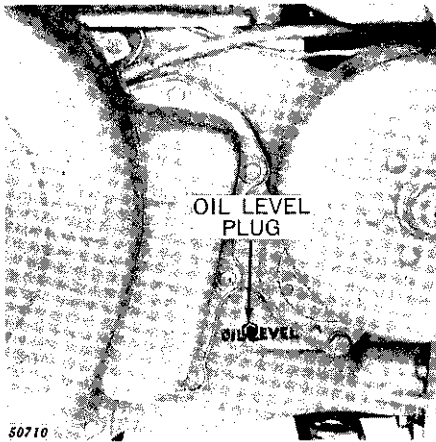

Figure 20-10-16—Diesel Engine Transmission Oil Level Plug

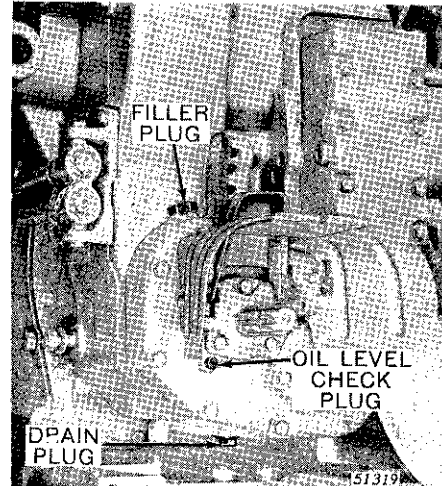

Figure 20-10-19—Powershaft Clutch Housing Oil Plugs

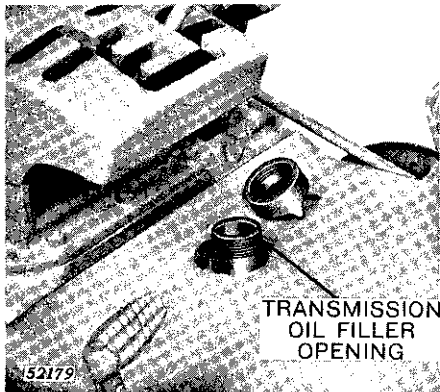

Figure 20-10-17—Diesel Engine Transmission Oil Filler Opening

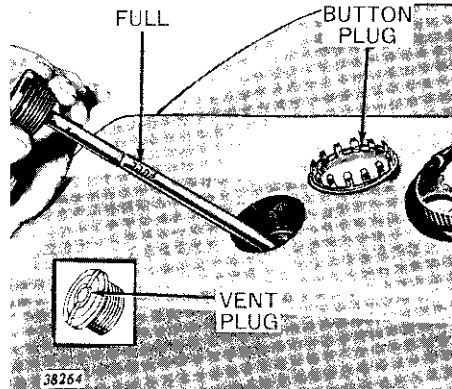

Figure 20-10-20—Power Steering Reservoir Dip Stick

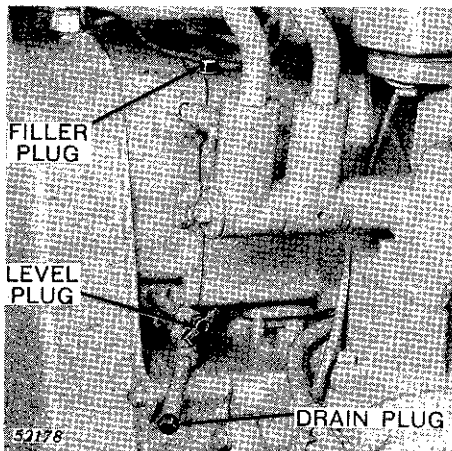

Figure 20-10-18—Cranking Engine Transmission Oil Plugs

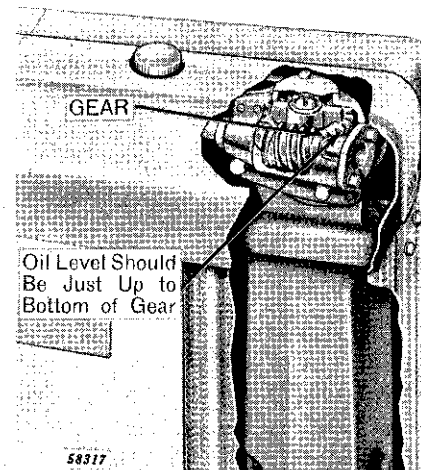

Figure 20-10-21—Steering Gear Oil Level (Manual Steering)

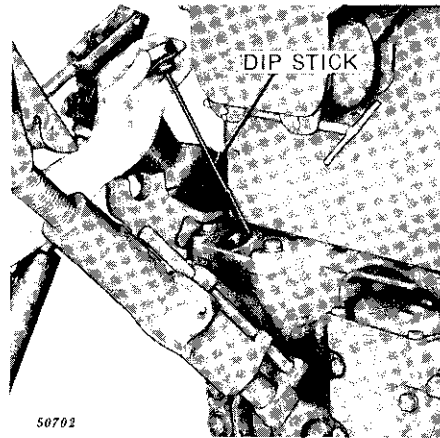

Figure 20-10-22—Powr-Trol Reservoir Dip Stick and Filler Opening

If oil is low in any of the units mentioned above, fill to the proper level, using oil of the correct type and weight as given in the chart below.

Lubricate the generator sparingly (Figure 20-10-23).

At the 150-Hour Service, lubricate the rear axle outer bearings by removing the pipe plugs from each rear axle housing, installing a grease fitting, and pumping 6 to 8 shots of pressure gun grease into both housings. Remove fittings and replace pipe plugs.

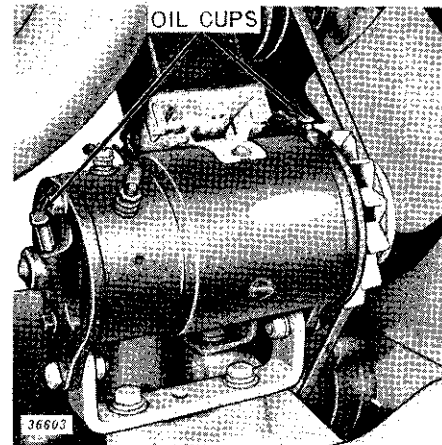

Figure 20-10-23—Generator Oil Cups

Remove cranking engine clutch adjusting cover and service fitting on clutch bearing collar with 3 or 4 shots of pressure gun grease (Figure 20-10-24).

Lubricate oil cup on cranking engine transmission (Figure 20-10-25).

Also at the 150-Hour Service, check crankcase oil level in both engines and service as necessary (see page 20-10-3).

Service all grease and oil fittings shown in the lubrication charts on the next pages.

**\*OIL WEIGHT CHART**

Unit	Oil Type	Weight		Capacity
Diesel Engine Transmission	Transmission Oil	0° F. Up.....	SAE 90	8 U.S. Gals.
		Below 0° F.....	SAE 80	
Cranking Engine Transmission	Engine Oil	SAE 30		1/2 U.S. Pint
Powr-Trol	Engine Oil	Above 90° F.	SAE 30	13 U.S. Qts. and 1 U.S. Qt. for Each Remote Cylinder
		32° to 90° F.	SAE 20 or 20W	
		Below 32° F.	SAE 10W	
PTO Clutch Housing	Engine Oil	SAE 10W		4-1/2 U.S. Qts.
Power Steering Reservoir	Special Power Steering Oil	.....		5 U.S. Qts.
Manual Steering Gear Housing	Multi-Purpose Gear Lubricant	SAE 90		To bottom of gear

\*For engine crankcase oil weights see page 20-10-4.



● LUBRICATION CHART (STANDARD TRACTOR) ●  
(Grease Gun Points)

Service all fittings as indicated on the chart below with pressure gun grease or new engine oil, wiping off fittings beforehand. **CAUTION: Stop the engine before lubricating the tractor.**

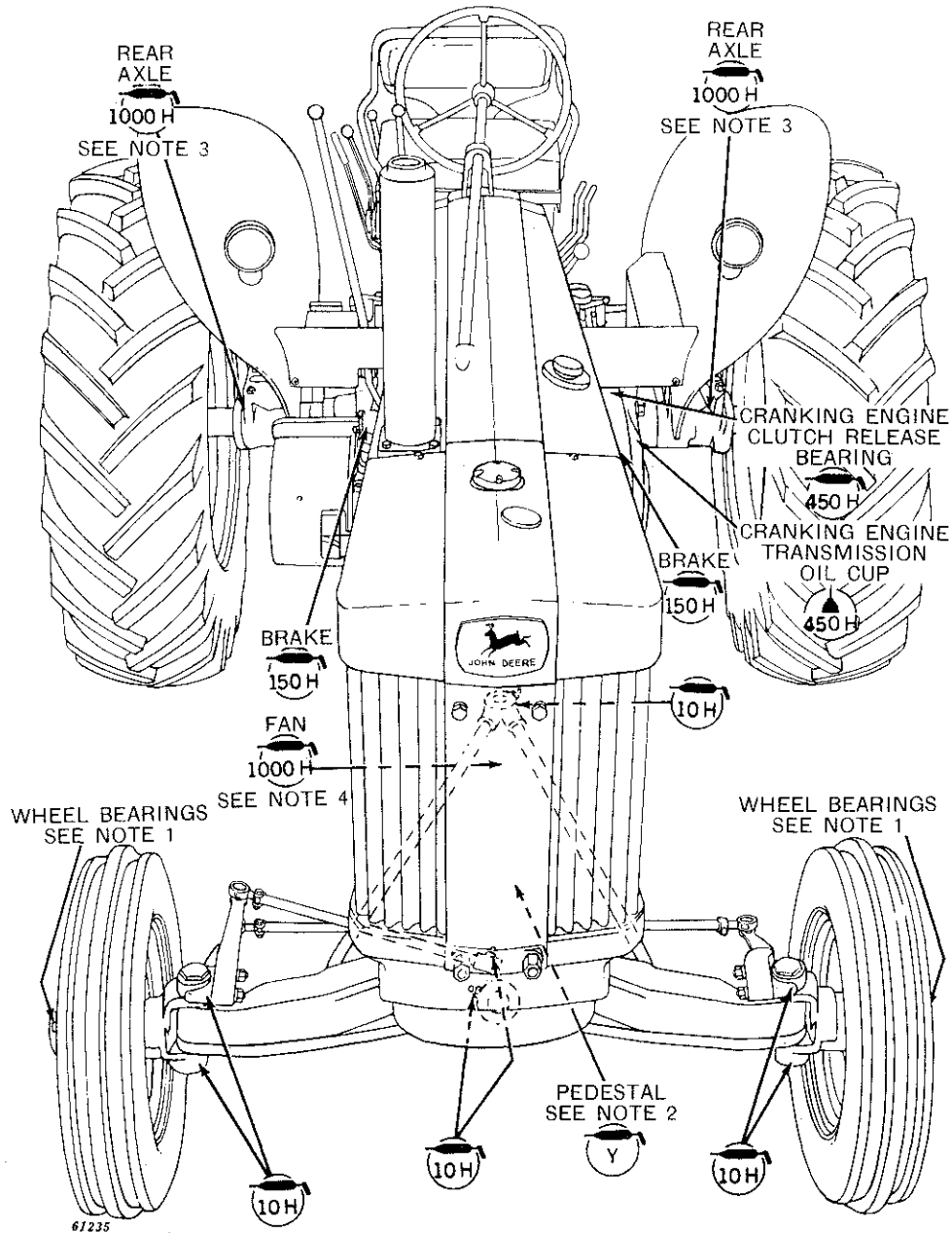
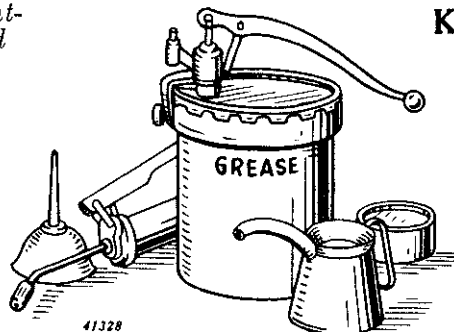

Figure 20-10-27—Lubrication Chart for Standard Tractor

For Universal Three-Point-Hitch lubrication points and "NOTES," see page 20-10-14.

**KEEP LUBRICANTS CLEAN!**

Use *only* high-grade lubricants which have been stored in clean containers. Wipe away all grease and dirt before removing filler caps or plugs.



### LUBRICATION CHART—Continued (Grease Gun Points)

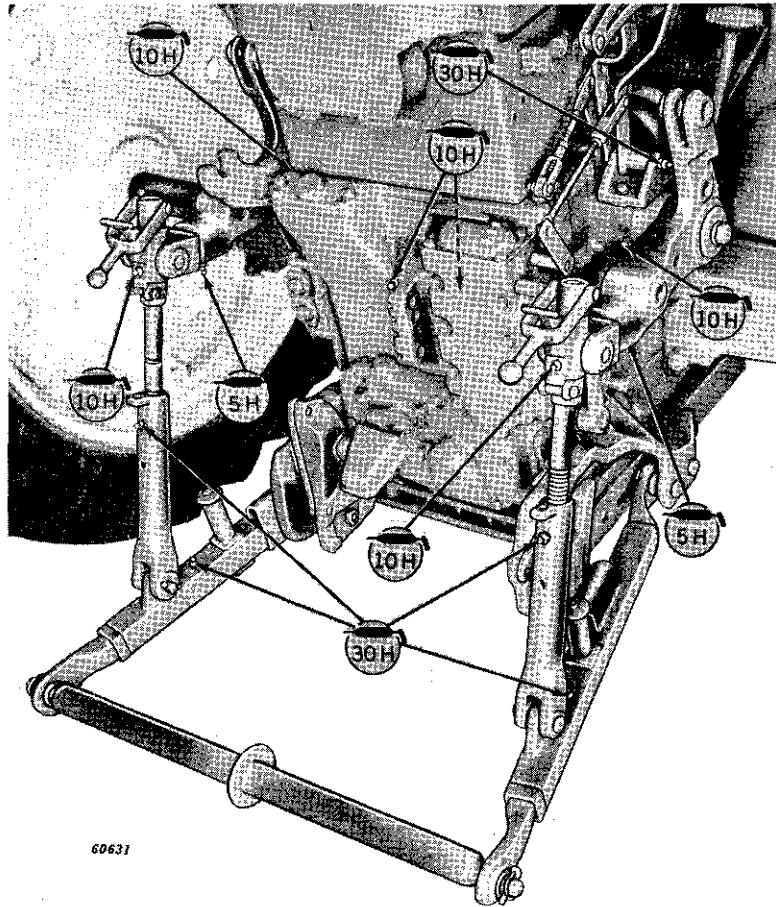

Figure 20-10-28—Lubrication Chart for Universal  
Three-Point Hitch

#### NOTES

NOTE 1: Front wheels are packed with wheel bearing grease at the factory and need cleaning and repacking every 6 months or 450 hours of operation, under normal conditions. Where there is danger of mud and water getting into the front wheel bearings due to operation in extremely wet and muddy conditions, grease front wheels every 10 hours with gun grease until the wheels can be removed and bearings cleaned and repacked with wheel bearing grease.

NOTE 2: Once a year remove grille, take out pipe plug located on lower end of pedestal, install a grease fitting, and lubricate pedestal bearing with pressure gun grease. **Do not over-lubricate.** Remove fitting and replace pipe plug and grille.

NOTE 3: Every 1000 hours of operation, remove pipe plugs from each rear axle housing, install a grease fitting, and pump 6 to 8 shots of pressure gun grease into both housings. Remove fittings and replace plugs. When operating in extremely wet and muddy conditions, grease both rear axles every 10 hours of operation with pressure gun grease.

NOTE 4: On tractors with manual steering, every 1000 hours of operation, remove pipe plug from fan bearing housing, install a grease fitting, and fill housing with wheel bearing grease. Remove grease fitting and replace pipe plug.



**Suggest:**

**If the above button click is invalid.**

**Please download this document**

**first, and then click the above link**

**to download the complete manual.**

**Thank you so much for reading**

## 11. ENGINES (150-HOUR SERVICE ONLY).

### Cranking Engine.

Start the engine (see *Section 10, Group 10*) and bring it up to operating temperature. Check ignition timing and engine speeds as explained in *Section 40, Group 20, of this Manual*. Engine speeds may be checked by removing the distributor cover and holding a speed indicator against the recess in the cap screw which retains the distributor cam to the crankshaft. Slow idle or "start" engine speed is approximately 4000 rpm. Fast idle or "run" speed is 5000 rpm and load speed is 4500 rpm. When properly adjusted, the cranking engine should turn the Diesel engine, on full compression, at approximately 200 rpm when the Diesel engine is at operating temperature.

Check carburetor adjustments and tappet lever clearance as described in *Section 40, Group 15, of this Manual*. Correct tappet lever clearance is 0.008-inch "go" to 0.010-inch "no go" for both intake and exhaust valves.

### Diesel Engine.

Start the Diesel engine and bring it up to operating temperature. Check oil pressure and generator operation by watching the gauges as described in paragraph 12, in this Group. If oil pressure adjustment is necessary, see *Section 40, Group 10, of this Manual*.

Check engine speeds as explained in *Section 40, Group 10*. Slow idle speed should be 700 rpm and fast idle, 1250 rpm.

While the engine is hot, tighten cylinder head stud nuts, including the two under the tappet lever bracket, to 275 foot-pounds torque. Tighten the three cap screws in the pump compartment securely. Tighten cylinder-block-to-case stud nuts to 275 foot-pounds torque.

Check and adjust tappet lever clearance as explained in *Section 40, Group 10*. The clearance should be 0.020-inch for both intake and exhaust valves.

Check and, if necessary, adjust exhaust valve opening on decompression, as explained in *Section 40, Group 10*.

## 12. OPERATION.

After the foregoing services have been performed, check the tractor for proper operation.

### Engines.

Start both engines and make sure they are running properly.

### Oil Pressure.

Oil pressure should register between "M" and "H" on the gauge with the engine running. If it does not, adjust according to instructions in *Section 40, Group 10, of this Manual*.

### Generator.

Check generator operation by noting the position of the hand on the ammeter with the engine running. If the battery is fully charged, very little if any charge will be indicated on the ammeter. To check the generator operation, start the engine and turn on the lights. The generator should charge enough to carry the light load and the ammeter should indicate zero or just a little charge. It should not indicate discharge.

### Clutch and Pulley Brake.

Check clutch and pulley brake operation as explained in paragraph 9 of this Group. It is important that the pulley brake be properly adjusted to stop the pulley when the clutch lever is pulled to the rear. If it is adjusted too tightly, hard gear shifting can result.

### Transmission, Steering Assembly and Brakes.

Shift through all transmission gears, test the steering for good action and the brakes for proper adjustment and operation.

**<https://www.ebooklibonline.com>**

Hello dear friend!

Thank you very much for reading.

Enter the link into your browser.

The full manual is available for immediate download.

**<https://www.ebooklibonline.com>**