

John Deere 644-B Loader



JOHN DEERE

TECHNICAL MANUAL John Deere 644-B Loader

TM1095 (01AUG78) English

John Deere Davenport Works
TM1095 (01AUG78)

LITHO IN U.S.A.
ENGLISH



JD644-B LOADER**Technical Manual
TM-1095 (Aug-78)****CONTENTS**

- Section 10 - GENERAL
 - Group 5 Specifications
 - Group 10 Predelivery, Delivery, and After Sales Services
 - Group 15 Lubrication
- Section 20 - ENGINE
 - Group 5 Engine Removal and Installation
 - Group 10 Basic Engine
 - Group 15 Engine Lubrication System
 - Group 20 Engine Cooling System
 - Group 25 Fuel System
 - Group 30 Speed Control Linkage (Refer to Section 70)
 - Group 35 Air Intake System
 - Group 40 Specifications and Special Tools
- Section 30 - ELECTRICAL SYSTEM
 - Group 5 Batteries
 - Group 10 Charging System
 - Group 15 Delco Remy Starting System
 - Group 20 John Deere Starting System
 - Group 25 Miscellaneous Electrical Components
 - Group 26 Heating and Air Conditioning Systems
 - Group 30 Specifications and Special Toolss
- Section 40 - POWER TRAIN
 - Group 5 Drive Shafts
 - Group 10 Damper Assembly
 - Group 15 Transmission
 - Group 20 Final Drives
 - Group 25 Differential
 - Group 30 Specifications and Special Tools
- Section 50 - HYDRAULIC SYSTEM
 - Group 5 Transmission Pump
 - Group 10 Transmission Control Valve
 - Group 15 Steering and Brake Pump
 - Group 20 Steering Valve
 - Group 25 Brake System
 - Group 30 Loader Pump
 - Group 35 Loader Control Valve
 - Group 40 Cylinders
 - Group 45 Miscellaneous Hydraulic Components
 - Group 50 Specifications and Special Tools
- Section 60 - MISCELLANEOUS COMPONENTS
 - Group 5 Loader and Engine Frames
 - Group 10 Loader Boom and Buckets
 - Group 15 Seats
 - Group 20 Canopy and Cab
 - Group 25 Specifications and Special Tools
- Section 70 - SYSTEM TESTING
 - Group 5 General Information - Seven Basic Steps of Testing and Diagnosis
 - Group 10 Engine
 - Group 15 Electrical System
 - Group 16 Heating and Air Conditioning Systems
 - Group 20 Power Train
 - Group 25 Hydraulic System
 - Group 26 Hydraulic System (Analyzer)
 - Group 30 Miscellaneous Components
 - Group 35 Specifications and Special Tools
- Section 80 - INDEX

The specifications and design information contained in this manual were correct at the time this machine was manufactured. It is John Deere's policy to continually improve and update our machines. Therefore, the specifications and design information are subject to change without notice. Wherever applicable, specifications and design information are in accordance with SAE and IEMC standards.

**Copyright® 1973
DEERE & COMPANY
Moline, Illinois
All rights reserved**

INTRODUCTION



Use FOS Manuals for Reference

This technical manual is part of a twin concept of service:

The two kinds of manuals work as a team to give you both the general background and technical details of shop service.

•FOS Manuals—for reference

Fundamentals of Service (FOS) Manuals cover basic theory of operation, *fundamentals* of trouble shooting, *general* maintenance, and *basic* types of failure and their causes. FOS Manuals are for training new personnel and for reference by experienced technicians.



When a service technician should refer to a FOS Manual for more information, a FOS symbol like the one at the left is used in the TM to identify the reference.

•Technical Manuals—for actual service

Technical Manuals are concise service guides for a specific machine. Technical manuals are on-the-job guides containing only the vital information needed by an experienced service technician.



Use Technical Manuals for Actual Service

This technical manual was planned and written for you an experienced service technician. Keep it in a permanent binder in the shop where it is handy. Refer to it whenever in doubt about correct service procedures or specifications.

Some features of this manual:

- Inside front cover - "Table of Contents" and "Maintenance Without Accident".
- Section 10 - General specifications and services.
- Sections 20 through 60 - Removal, repair, testing (components removed), installation, and adjustment.
- Section 70 - Detailed explanation of system operation, diagnosis, visual inspection, testing, and adjustments.
- Specifications grouped and illustrated at the end of each section.

<https://www.ebooklibonline.com>

Hello dear friend!

Thank you very much for reading.

Enter the link into your browser.

The full manual is available for immediate download.

<https://www.ebooklibonline.com>

MAINTENANCE WITHOUT ACCIDENT WORK SAFELY



T27999

 This safety alert symbol identifies important safety messages in this manual and on the loader. When you see this symbol, be alert to the possibility of personal injury and carefully read the message that follows.

**EVERY EMPLOYER HAS A
SAFETY PROGRAM. KNOW
WHAT IT IS!**

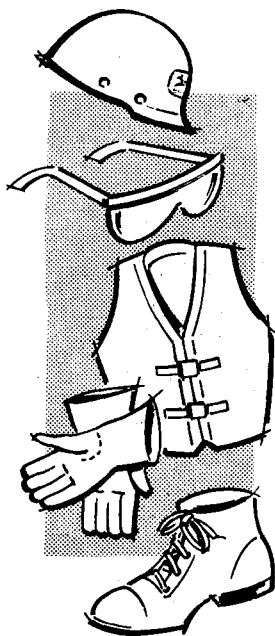

T27501N

Consult your shop foreman for specific instructions on a job, and the safety equipment required.

For instance, you may need: Hard hat, safety shoes, safety goggles, heavy gloves, reflector vests, ear protectors, respirators.

Litho in U.S.A.



T27502N

ALWAYS AVOID loose clothing or any accessory—flopping cuffs, dangling neckties and scarves, or rings and wrist watches—that can catch in moving parts and put you out of work.

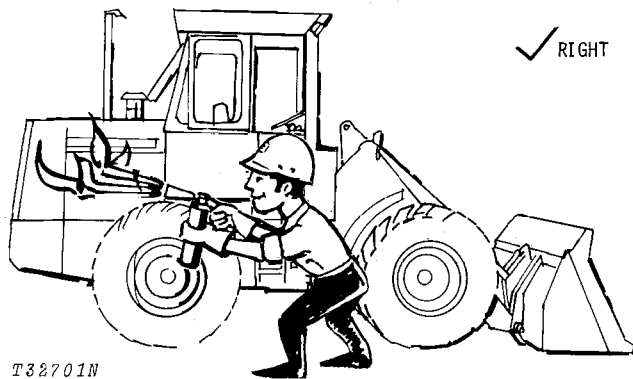

T32701N

BE ALERT!

Plan ahead — work safely — avoid accidental damage and injury. If a careless moment does cause an accident or fire, react quickly with the tools and skills at hand — know how to use a first aid kit and a fire extinguisher — and where to get aid and assistance. In an emergency, split-second action is the key to safety.

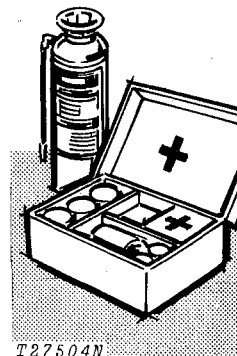

T27504N

MAINTENANCE WITHOUT ACCIDENT

Specific safety procedures should always be observed, whether servicing the equipment or making the repairs. Remembering these—in time!—can prevent an injury... or save your life....

AVOID FIRE HAZARDS—

Fuel Is Dangerous!

Don't smoke while refueling.

Don't smoke while handling highly flammable material.

Engine should be shut off when refueling.

Use care in refueling if the engine is hot.

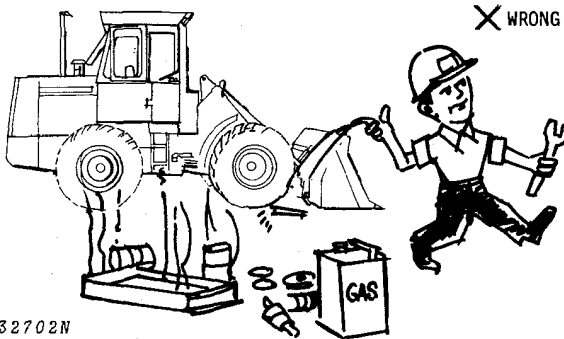

T32702N

Don't use open pans of gasoline or diesel fuel for cleaning parts. Good commercial, nonflammable solvents are preferred.

Flame Is Not a Flashlight!

Never check fuel, battery electrolyte or coolant levels with an open flame.

Never use an open flame to look for leaks anywhere on the equipment.

Never use an open flame as a light anywhere on or around the equipment.

Know Where Fire Extinguishers Are Kept!



T27508N

Battery Gas Is Highly Flammable!

Provide adequate ventilation when charging batteries.

Don't check battery charge by placing metal objects across the posts.

Don't allow sparks or open flame near batteries.

Don't smoke near battery.

UNDER ALL MAINTENANCE CONDITIONS—

Do not perform any work on the equipment unless authorized to do so. Then be sure you follow recommended procedures.

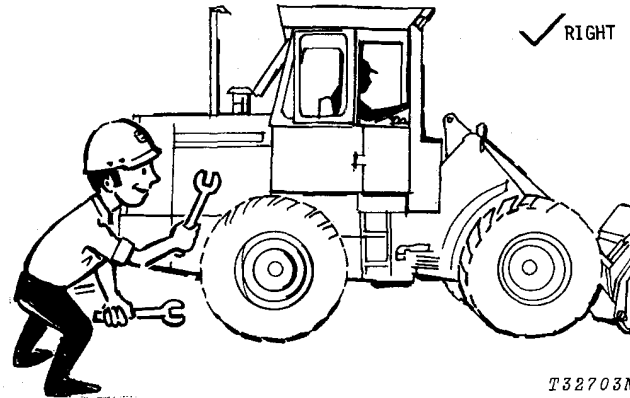

T32703N

Never service the equipment while it is being operated.

Avoid working on equipment with the engine running. If it is necessary to make checks with the engine running. **ALWAYS USE TWO TECHNICIANS**—one, the operator, at the controls, the other checking where the operator can see. Also, put the transmission in neutral, set the parking brake, and apply any safety locks provided. **KEEP HANDS AWAY FROM MOVING PARTS.**

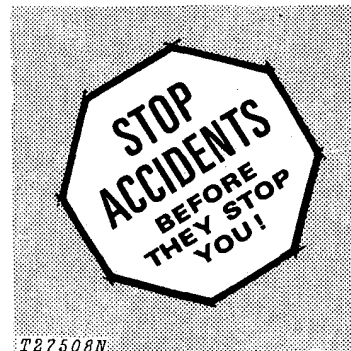

T27508N

MAINTENANCE WITHOUT ACCIDENT

Before servicing, adjusting, or repairing loaders which have attachments such as log and lumber forks, buckets, etc.—**LOWER** attachments to the ground—or, if necessary to raise them for access to certain parts, **SECURELY SUPPORT** by external means. **DO NOT** rely on controls to support or position attachments for maintenance.

Never allow **ANYONE** to walk under equipment that is raised and not properly blocked.

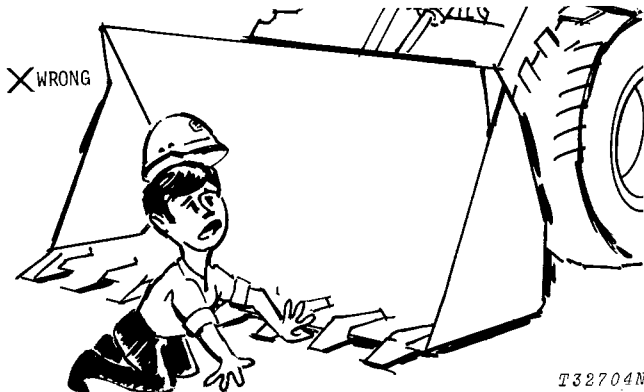

Avoid working directly under raised and blocked equipment unless absolutely necessary.

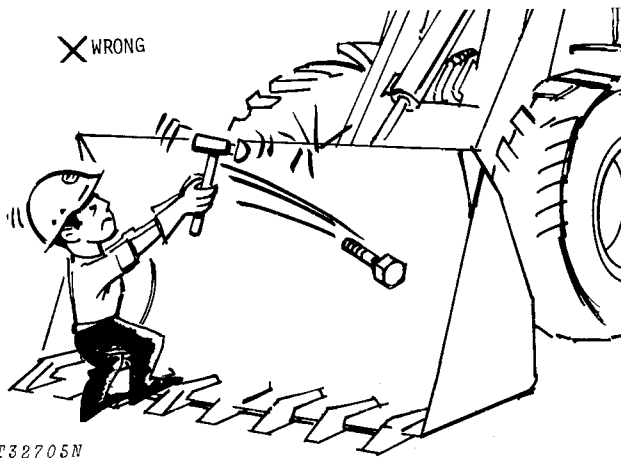

Wear safety glasses when drilling, grinding, or hammering metal.

If the machine is on an incline, block it securely.

Use hoisting equipment for lifting heavy parts. **TAKE CARE! WATCH OUT FOR OTHER PEOPLE IN THE VICINITY.**

Use extreme caution in removing radiator caps, drain plugs, grease fittings, or hydraulic pressure caps.

Make sure the maintenance area is adequately vented.

Keep maintenance area **CLEAN AND DRY**. Oily and wet floors are slippery; greasy rags are a fire hazard; wet spots are dangerous when working with electrical equipment.

Store starting aids in a cool and well-ventilated place, out of the reach of unauthorized personnel.

SERVICING PRECAUTIONS

Stop the engine before cleaning or lubricating the equipment.

Lower mounted equipment and tools to the ground *carefully*.

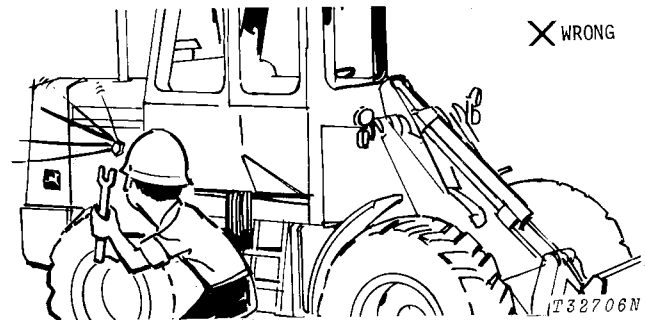

Engine coolant gets hot! Don't remove the radiator cap until coolant temperature is below the boiling point. Then turn cap slightly to relieve pressure before removing.

Exhaust gases are dangerous! Periodically check exhaust system for excessive leakage.

Don't forget a hydraulic system may be pressurized! To relieve pressure, follow the technical manual.

The loader is equipped with a hydraulic accumulator—recharge by using only dry nitrogen. Again follow the technical manual for procedure.

When checking hydraulic pressure, be sure to use the correct test gauge for the pressure in the particular system.

MAINTENANCE WITHOUT ACCIDENT

When preparing engine for storage, remember that inhibitor is volatile and therefore dangerous. Seal and tape openings after adding the inhibitor. Keep container tightly closed when not in use.

RIGHT ✓

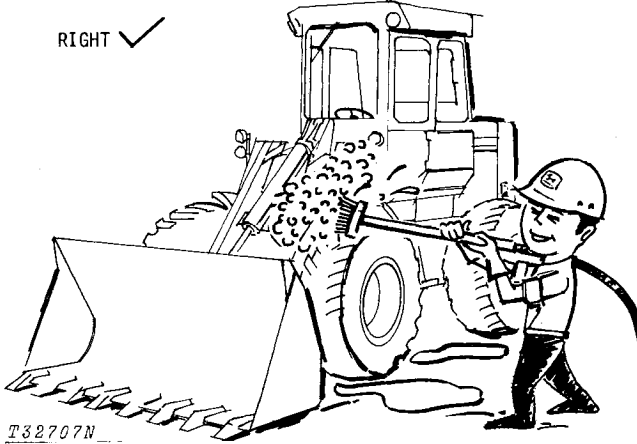

T32707N

Keep ALL equipment free of dirt and oil. This attention will minimize fire hazards and facilitate spotting of loose or defective parts.

ADJUSTING PRECAUTIONS

.... for Operating Adjustments

Keep clutch and brake control units properly adjusted at all times. Before making adjustments, stop engine.

X WRONG



T32708N

Before removing any housing covers, stop engine. Take all objects from your pockets which could fall into the opened housings. Don't let adjusting wrenches fall into opened housings.

.... for Maintenance Adjustments

X WRONG



T32709N

Don't attempt to check belt tension while the engine is running.

Don't adjust the fuel system while the machine is in motion.

MAINTENANCE WITHOUT ACCIDENT

PRECAUTIONS DURING REPAIR

Before working on hydraulic systems—make sure engine is not running and the system pressure is relieved by working the control levers, steering wheel and brakes in all directions with the engine shut off.

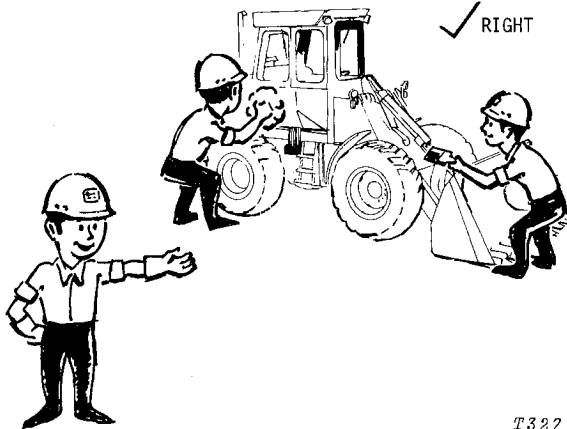

T32710N

Before repairing the electrical system, or performing a major overhaul, make sure the batteries are disconnected.

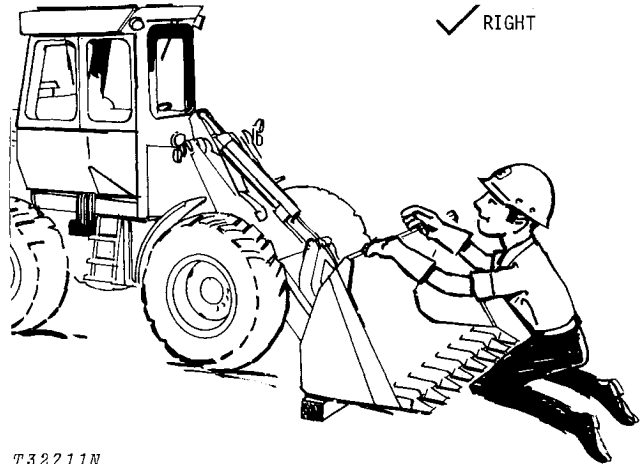

T32711N

When changing cutting edges on bucket—
Stop the engine and securely block the bucket.
Never let your bare hands come in contact with the sharp edges. WEAR GLOVES.



T27508N

MAINTENANCE WITHOUT ACCIDENT

KNOW EQUIPMENT IS READY!

Check guards, canopies, safety bars—all protective devices installed on the loader. Every one should be in place and secure.

CHECK IT OUT!

- GUARDS
- CANOPIES
- SHIELDS
- PROTECTIVE DEVICES
- ROLL-OVER PROTECTIVE STRUCTURES
- SEAT BELTS, ETC.

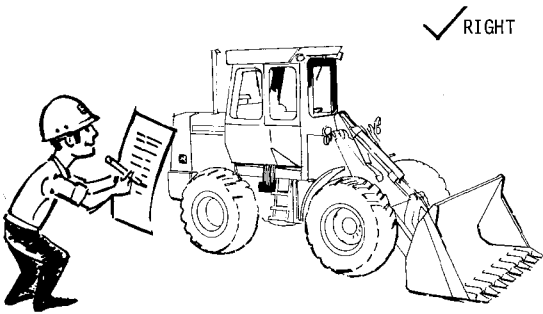

T32712N

Carefully inspect equipment for visual defects—leaks in fuel, lubrication, and hydraulic systems. Do not search for pressurized fluid leaks with your hands. Use cardboard or wood to search for leaks.

Check and secure all caps and filler plugs for fuel, oils, radiator, etc.

✗ WRONG

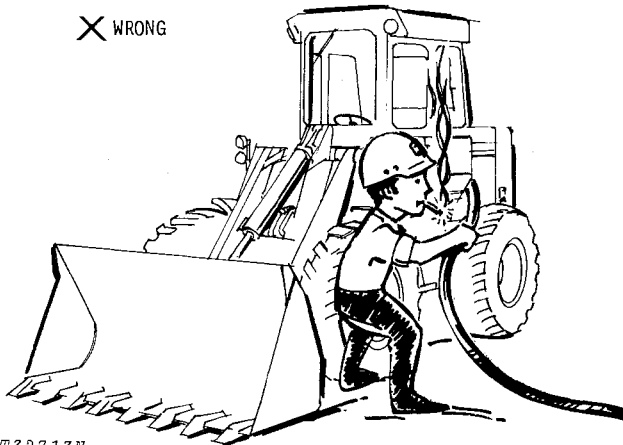

T32713N

Check levels of fuel, coolant, hydraulic fluid, and lubricating oil. If fuel must be added—**FIRST, PUT OUT THAT CIGARET.**

Litho in U.S.A.

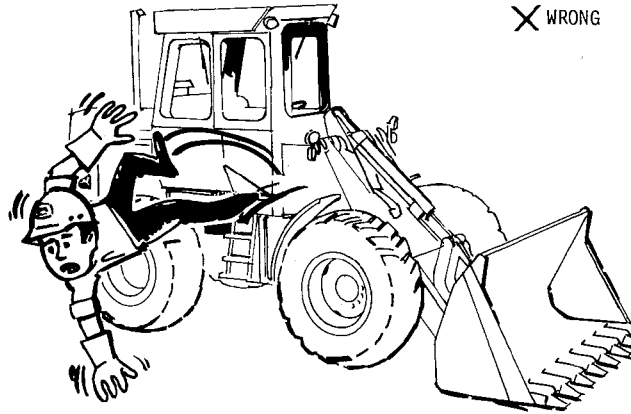

T32714N

Be sure to clean any oil, grease or mud accumulation from floor of operator's compartment, stepping points, and grab rails to minimize the danger of slipping.

In freezing weather beware of snow or ice deposits on stepping points, grab rails, and floor.

Remove loose bolts, tools, or other objects from floor of operator's compartment.

Although it is impractical to try to cover every possible maintenance situation, the safety precautions recommended here should serve to develop and promote safe maintenance procedures.

The information contained in this manual is not intended to replace safety codes, insurance requirements, federal, state, and local laws, rules and regulations. In particular, your service area or jobsite activities may be subject to state safety rules and/or federal regulation under the Occupational Safety and Health Act (OSHA). Familiarize yourself with all regulations applicable to your situation in order to avoid possible safety violations.

Illustrations and copy reproduced in part by permission of Construction Industry Manufacturers' Association (CIMA).

Section 10 GENERAL

CONTENTS OF THIS SECTION

	Page		Page
GROUP 5 - SPECIFICATIONS		GROUP 15 - LUBRICATION	
General Machine Specifications	5-1	General Information	15-1
GROUP 10 - PREDELIVERY, DELIVERY, AND AFTER SALE SERVICES		Loader Periodic Service Chart	15-1
Temporary Machine Storage	10-1	Engine Lubricating Oils	15-2
Predelivery Service	10-1	Transmission, Steering, and Brake Oils	15-2
Delivery Service	10-15	Loader Hydraulic Oil	15-2
After-Sale Inspection	10-15	Greases	15-2

Group 5 GENERAL MACHINE SPECIFICATIONS

(Specifications and design are subject to change without notice. Wherever applicable, specifications are in accordance with ICED and SAE Standards. Except where otherwise noted, specifications are based on a machine equipped with all standard equipment, 20.5-25, 12-ply, loader-tread tires with 1820 lb. (826 kg) of CaCl₂ solution in rear tires, side counterweights, ROPS cab, full fuel tank, and 175 lb. (79.4 kg) operator.)

Power (at 2,200 engine rpm):	SAE	DIN
Gross	160 (119.3 kW*)	
Net	145 (108.1 kW*)	147.5 PS

**Net engine flywheel horsepower is for an engine equipped with fan, air cleaner, water pump, lubricating oil pump, fuel pump, alternator, and muffler. The gross engine power is without fan. Flywheel power ratings are under SAE standard conditions of 500 ft. (152 m) altitude and 85°F. (29.4°C) temperature and DIN 70 020 conditions (non-corrected). No derating is required up to 10,000 ft. (3 000 m) altitude.*

**In the international system of units (SI), power is expressed in kilowatts (kW).*

Engine: John Deere turbocharged diesel, vertical 6-cylinder, valve-in-head, 4-stroke cycle.

Bore and stroke

4.75 x 5 in.	
	(120.5 mm x 127 mm)

Piston displacement

531 cu. in. (8 702 cm ³)	
--------------------------------------	--

Compression ratio

15.8 to 1	
-----------	--

Maximum torque @ 1500 rpm

432 lb-ft	
	(59.7 kg-m)

NACC or AMA (U.S. Tax) horsepower

54.0	
------	--

Lubrication

Pressure system with full-flow filter	
---------------------------------------	--

Cooling

Pressurized with thermostat and fixed bypass	
--	--

Fan

Blower	
--------	--

Air cleaner with restriction indicator

Dry	
-----	--

Electrical system

12-volt (12V) with alternator	
-------------------------------	--

Batteries (2)

Reserve capacity: 310 minutes each battery	
--	--

Torque Converter:	
Type	Twin-turbine
Torque multiplication	4.9 to 1

Transmission

Power shift planetary	
-----------------------	--

Forward Speeds	mph	km/h
1	0-3.3	0-5.3
2	3.3-7	5.3-12.6
3	0-12.5	0-20.1
4	12.5-25.8	20.1-41.5

Reverse Speeds		
1	0-4.5	0-7.2
2	4.5-10.2	7.2-16.4

NOTE: Shift from 1st to 2nd and 3rd to 4th is automatic.

Differentials:	
Front	No-Spin
Rear	Standard

Drive Axles ... Inboard-mounted planetary gears to each wheel. Front axle fixed. Rear axle oscillates 22-degree total. 15.3 inches (389 mm) vertical travel at center of tire.

Brakes:

Service. . . Power actuated, 4-wheel, inboard-mounted wet disk. Foot-operated by either right or left pedal. Parking. . . 10 x 1.5-inch (254 mm x 38 mm) expanding shoe on transmission output shaft. Adjustable, hand-operated with warning light and buzzer.

Steering Full power steering. Frame articulated 80 degrees by two hydraulic cylinders. Turning radius of 15 feet 5 inches (4.7 m).

Hydraulic Systems:

Loader functions. . . Independent engine-driven, gear pump delivers 58.2 gpm (220 Lpm) at 600 psi (42 kg/cm²) and 220 engine rpm. 2,250 psi (158.2 kg/cm²) relief-valve pressure setting.

Control Single-lever, dual hydraulic valve. Optional triple hydraulic valve for fork or multipurpose bucket.

Steering and brakes. . . Engine-driven, eight-piston, variable-displacement pump delivers 26.5 gpm (100 Lpm) at 2,200 engine rpm and 2,000 psi (140.6 kg/cm²). Maximum system pressure is 2,400 psi (169 kg/cm²).

Hydraulic

Cylinders:	Bore	Stroke
Boom, two . . .	6.25 in. (159 mm)	25.55 in. (649 mm)
Bucket, one . . .	6.25 in. (159 mm)	29.60 in. (752 mm)
Cylinder rods	Ground, heat-treated, chrome-plated, polished	
Boom and bucket cylinder rods	2.75 in. (70 mm) dia.	

Tires:

- 17.5-25, 12-ply-rating, loader tread, L-2
- 20.5-25, 12-ply-rating, rock tread, L-3
- 20.5-25, 12-ply-rating, loader tread, L-2
- 20.5-25, 16-ply-rating, rock tread, L-3

Wheel Treads:

Front and rear 80 in. (2.03 m)

Capacities:

	U.S.	Litres
Cooling system	49 qt.	46.4
Fuel tank	56 gal.	211.9
Crankcase	20 qt.	18.9
Crankcase, includes filter	22 qt.	20.8
Transmission case and filters	39 qt.	36.9
Front differential	24 qt.	22.7
Rear differential	25 qt.	23.7
Loader hydraulic sump	70 qt.	66.2

Additional Standard Equipment:

- Adjustable cushioned seat
- Engine side shields
- Front fenders
- Gauges:
 - Transmission oil temperature
 - Transmission oil pressure
 - Fuel
 - Coolant temperature
 - Engine oil pressure
 - Electric hour meter
 - Voltmeter
- Loader hydraulic system indicator
- Key switch
- Pushbutton safety start
- Cigar lighter
- Parking brake warning light and buzzer
- Transistorized voltage regulator
- Vandal protection
- Horn
- Lights
- Fuel filter
- Automatic return-to-dig
- Rear counterweight
- Fixed drawbar
- Exhaust w/rain cap
- Rear bottom guard
- Hand grips
- ROPS w/cab and seat belt
- Heater
- Antifreeze
- Cold weather starting aid
- Flashing and turning lights
- Work lights
- Precleaner

Special Equipment:

- Rear axle disconnect
- ROPS canopy and seat belt
- Instrument panel cover with lock
- Reverse warning alarm
- Triple loader hydraulic valve
- Bucket teeth
- Auxiliary side weights
- Splash guard for fenders
- Front bottom guard
- License plate bracket
- Defroster fan
- Automatic boom height control
- Engine coolant heater
- SMV emblem
- ROPS quiet cab
- Auxiliary cutting edges
- Air conditioning
- Adjustable suspension seat

DIMENSIONS

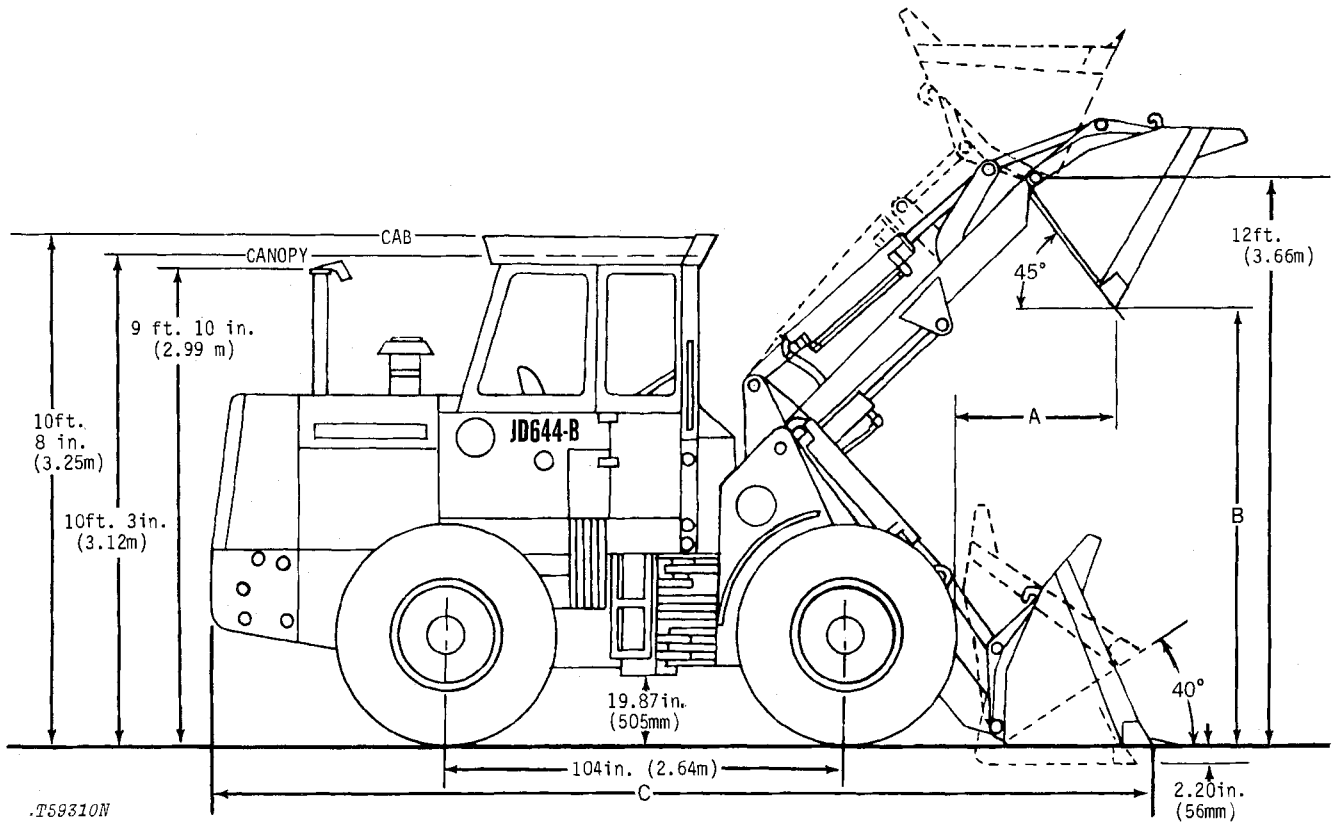

BUCKET CAPACITIES	DIMENSIONS		
	A	B	C
2-1/2 cu. yd. bucket	34.6 in. (87 mm)	9 ft. 4 in. (2.84 m)	21 ft. 0.06 in. (6.40 m)
3 cu. yd. bucket	37.8 in. (9 mm)	9 ft. 0.9 in. (2.7 m)	21 ft. 5.1 in. (6.53 m)
4-1/2 cu. yd. bucket	45 in. (1 143 mm)	8 ft. 5.7 in. (2.58 m)	22 ft. 3.3 in. (6.79 m)
2-1/2 cu. yd. multipurpose	36.3 in. (922 mm)	8 ft. 8.4 in. (2.65 m)	21 ft. 11.8 in. (6.70 m)

OPERATING INFORMATION

OPERATING INFORMATION	BUCKET			
	General purpose	General purpose	Loose materials	Multipurpose
Capacity, heaped, SAE	2-1/2 cu. yd. (1.91 m ³)	3 cu. yd. (2.29 m ³)	4-1/2 cu. yd. (3.44 m ³)	2-1/2 cu. yd. (1.91 m ³)
Capacity, struck, SAE	2.05 cu. yd. (1.57 m ³)	2.50 cu. yd. (1.80 m ³)	3.73 cu. yd. (2.45 m ³)	1.92 cu. yd. (1.47 m ³)
Bucket width	104.75 in. (2.66 m)	104.75 in. (2.66 m)	110.75 in. (2.81 m)	104.75 in. (2.66 m)
Bucket weight	1930 lb. (875 kg)	2115 lb. (959 kg)	2530 lb. (1148 kg)	3260 lb. (1479 kg)
Breakout force, J732C SAE Standard using bucket hinge pin as pivot	24,120 lb. (108.11 kN) (10 940 kg)	21,080 lb. (94.48 kN) (9 562 kg)	15,975 lb. (71.60 kN) (7 246 kg)	20,270 lb. (90.85 kN) (9 194 kg)
Tipping load, straight	22,905 lb. (10 390 kg)	22,420 lb. (10 170 kg)	21,480 lb. (9 743 kg)	19,910 lb. (9 031 kg)
Tipping load, 40-deg. Full Turn, SAE	19,610 lb. (8 895 kg)	19,160 lb. (8 691 kg)	18,280 lb. (8 292 kg)	16,855 lb. (7 645 kg)
Turning clearance, outside bucket	35 ft. 10 in. (10.92 m)	36 ft. 1 in. (11 m)	37 ft. (11.27 m)	36 ft. 5 in. (11.1 m)
Loader operating weight	28,100 lb. (12 746 kg)	28,280 lb. (12 828 kg)	28,695 lb. (13 016 kg)	29,425 lb. (13 347 kg)

Maximum recommended material weight, lb. per cu. yd. (kg/m³):

All standard equipment with 20.5-25, 12-ply-rating tires	2-1/2 cu. yd. (1.91 m ³) General purpose	3 cu. yd. (2.29 m ³) General purpose	4-1/2 cu. yd. (3.44 m ³) Loose materials	2-1/2 cu. yd. (1.91 m ³) Multipurpose
Loader less cab or canopy	2575 (1 528)	2085 (1 237)	1315 (780)	2152 (1 276)
Loader with canopy	2660 (1 578)	2160 (1 282)	1360 (807)	2230 (1 323)
Loader with cab	2715 (1 610)	2205 (1 308)	1390 (825)	2275 (1 350)
Loader with cab and fluid	3090 (1 833)	2515 (1 492)	1590 (943)	2630 (1 560)
Loader with cab, fluid, and first set of side counterweights	3450 (2 047)	2810 (1 667)	1785 (1 059)	2965 (1 759)
Loader with cab, fluid, first and second sets of side counterweights	3795 (2 252)	3095 (1 836)	1975 (1 172)	3285 (1 949)

Adjustments to operating weights and tipping loads:

Add (+) or deduct (-) lb. (kg) as indicated for loader equipped with:	Loader Operating Weight	Tipping Load, Straight	Tipping Load, 40- deg. Full Turn, SAE
Less ROPS cab	-950 lb. (431 kg)	-830 lb. (377 kg)	-770 lb. (349 kg)
ROPS canopy in lieu of ROPS cab	-320 lb. (145 kg)	-305 lb. (138 kg)	-275 lb. (125 kg)
Less side counterweights	-1175 lb. (533 kg)	-2430 lb. (1 102 kg)	-2025 lb. (919 kg)
17.5-25, 12-ply-rating, loader tread tires	-184 lb. (83 kg)	-250 lb. (113 kg)	-215 lb. (98 kg)
20.5-25, 12-ply-rating, rock tread tires	+174 lb. (79 kg)	+230 lb. (104 kg)	+200 lb. (91 kg)
Less CaCl ₂ in rear tires	-1820 lb. (826 kg)	-2435 lb. (1 105 kg)	-2115 lb. (959 kg)
Second set of side counterweights	+1294 lb. (587 kg)	+2300 lb. (1 043 kg)	+1945 lb. (882 kg)
Bucket teeth	+230 lb. (105 kg)	-330 lb. (150 kg)	-330 lb. (150 kg)

Group 10 PREDELIVERY, DELIVERY, AND AFTER-SALE SERVICES

TEMPORARY STORAGE

After receiving your loader from the factory and before putting the machine into temporary storage perform the following checks.

For long term storage (over 30 days) information, consult your JD644-B Operator's Manual.

1. Check battery electrolyte level and charge the battery, if necessary.
2. Check coolant level in the radiator. The coolant should be maintained at a level midway between the radiator core and filler neck.
3. Fill the fuel tank.
4. Check crankcase oil level. Oil should be at top mark of dipstick after loader has been shut down for ten minutes.
5. Relieve hydraulic pressure by stopping engine, lowering bucket and operating steering wheel or control levers until system fails to respond.

PREDELIVERY SERVICE

Because of the shipping factors involved, plus extra finishing touches that are necessary to promote customer satisfaction, proper predelivery service is of prime importance to the dealer and the customer.

If adjustments are required, procedures are found in the After-Sale section.

Use the following check list when preparing a loader for delivery to the customer.

1. Pre-cleaner

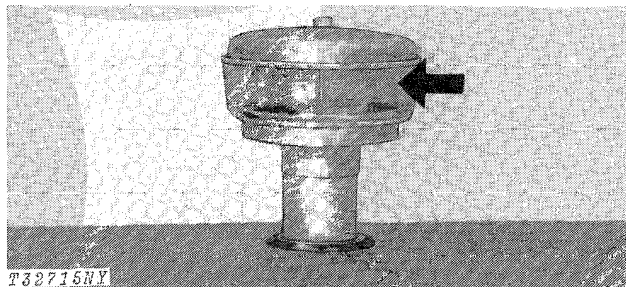

Fig. 1-Pre-cleaner

Check and clean pre-cleaner bowl.

Pre-cleaner checked and cleaned.

Yes No

2. Air Cleaner

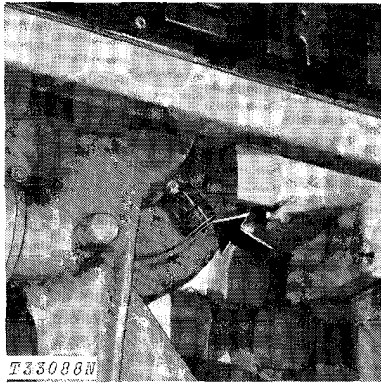
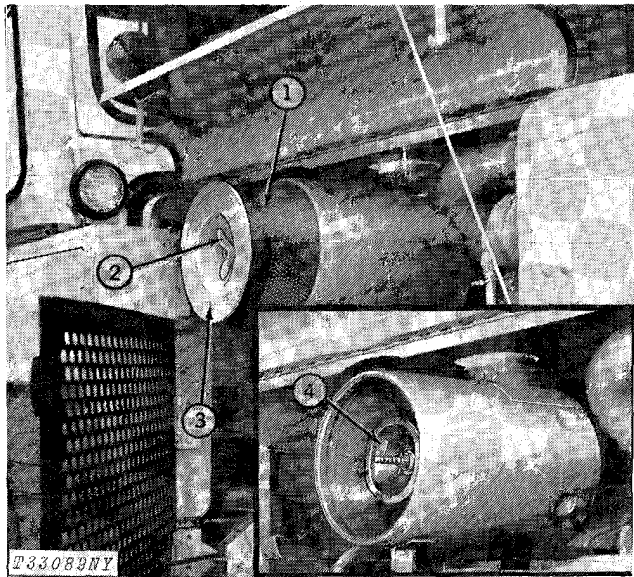

Fig. 2-Air Cleaner Restriction Indicator

Check air cleaner restriction indicator. If red signal locks in full view, look for restriction or blockage in air intake system.



- 1—Primary Element
- 2—Wing Nut
- 3—Air Cleaner Cover
- 4—Safety Element

Fig. 3-Air Cleaner

Air cleaner checked Yes No

Filters replaced Yes No

3. Fuel Filters

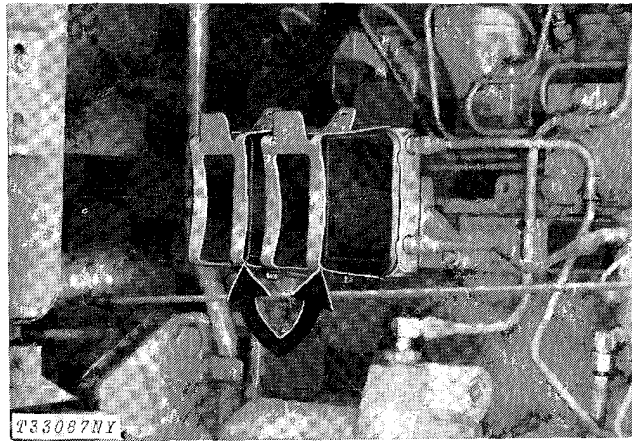

Fig. 4-Fuel Filters

Check fuel filters and drain any sediment that is present.

Sediment present in filters Yes No

4. Air Intake Hoses

Check air intake hoses for loose or improper connections. Check air cleaner-to-exhaust stack aspirator hose for restrictions, damage or loose connections.

Hoses checked Yes No

5. Batteries

Check battery electrolyte level. Batteries are located to the left of the operator and are accessible through the top door in the battery compartment. If distilled water is not available, use clean soft water. Avoid use of hard water. Remove foreign material from top of battery and coat terminals with petroleum jelly.

IMPORTANT: Never add water to battery in freezing weather unless engine is to be run long enough (two or three hours) to assure mixing of water and electrolyte.

Check battery connections.

Punch date code on battery.

Water added Yes No

6. Fuel Tank

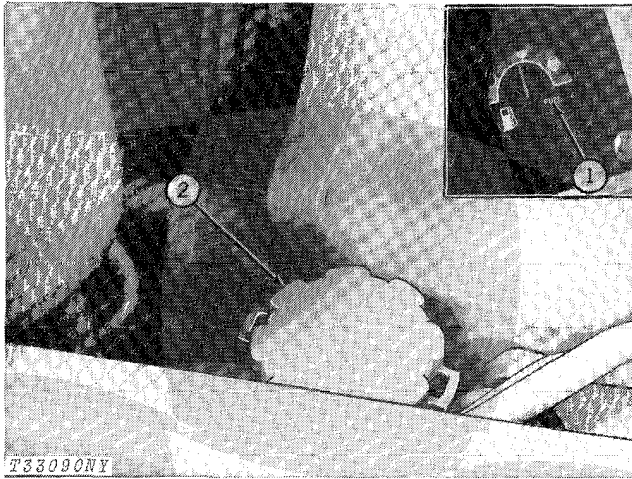

1—Fuel Gauge 2—Fuel Tank Filler

Fig. 5-Fuel Tank Filler and Fuel Gauge

Check the fuel gauge. If fuel gauge indicates a low fuel supply, add sufficient fuel to fill the fuel tank. Fuel tank capacity is 56 U.S. gal. (211.9 L).

Fuel tank level Full 1/2 Full Empty

7. Radiator

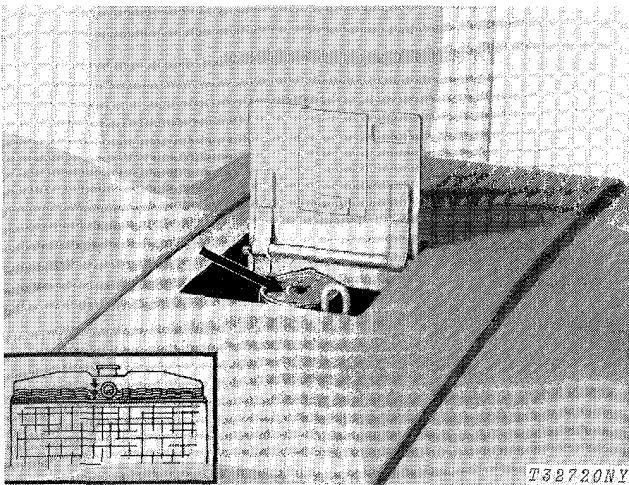

Fig. 6-Radiator Cap

Check coolant level in the radiator. Coolant level should be midway between the radiator core and filler neck.

Radiator coolant level checked Yes No

Coolant or anti-freeze added Yes No

8. Crankcase Oil Level

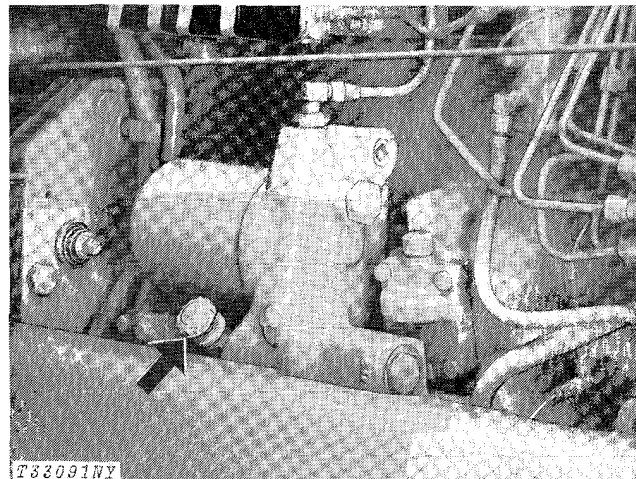

Fig. 7-Crankcase Dipstick

Check crankcase oil level with loader on level ground and the engine off. (Allow a minimum of 10 minutes for the oil to drain down before checking. If oil level is at or below bottom mark on dipstick, add sufficient oil of the proper viscosity and type specified on page 10-15-2 to bring oil level up to the top mark on the dipstick.

NOTE: There is a two-quart (1.89 L) difference between the bottom mark and the top mark on the dipstick.

Crankcase oil level checked Yes No

Oil added Yes No

9. Hydraulic Oil Level

Check loader hydraulic system oil level.

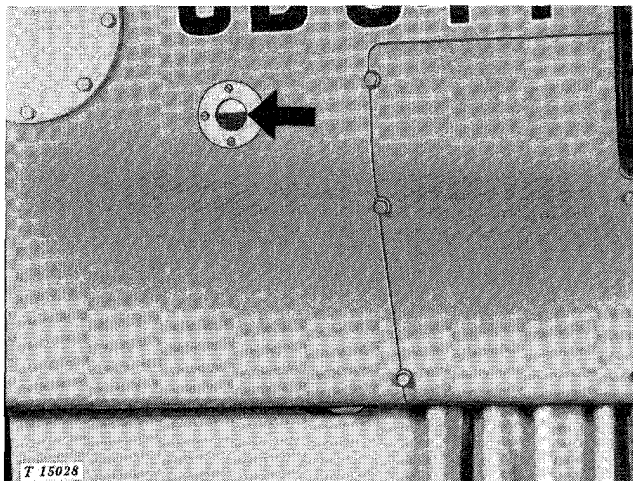

Fig. 8-Loader Hydraulic System Window Indicator

Check loader hydraulic system oil level with bucket resting on the ground. The oil level should be halfway up the window on the reservoir. If oil is low, add oil as specified on page 10-15-2 to bring level up to this point. The filler opening is located under the lid on top of the reservoir. Prevent dirt from entering system. Do not overfill.

Hydraulic system oil level checked _____ Yes No
 Oil added, if any _____ qts. (L)

10. Transmission Oil Level

Check transmission oil level.

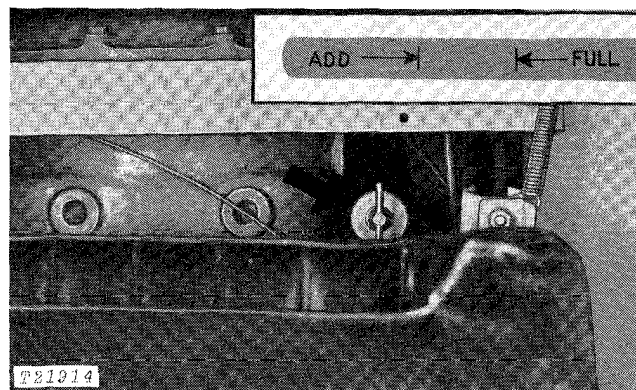

Fig. 9-Transmission Dipstick

A dipstick, located on the left side of the transmission, is accessible by tilting the back of the seat forward. The correct oil level check is made with the dipstick fully inserted in dipstick tube.

Perform both of the following transmission oil level checks: (a) Before starting the engine check the oil level with dipstick. If the oil level is at or near the upper (FULL) mark, there is sufficient oil in the system to permit starting the engine. If oil level is low add John Deere Torque-Converter Fluid (Type C-3) or equivalent. Replace dipstick and tighten finger tight.

(b) Operate loader until the transmission reaches normal operating temperature. Idle the engine and shift through all ranges slowly. This will fill all parts in the system with oil. Shift to neutral, apply the brakes and allow engine to idle. Check oil level again. It should now be at or above the lower (ADD) mark and not above the upper (FULL) mark on the dipstick. If not, add oil. Do not overfill.

Transmission oil level checked _____ Yes No
 Transmission oil added, if any _____ qts. (L)

11. Front and Rear Differential Oil Level

Check front and rear differential oil level.

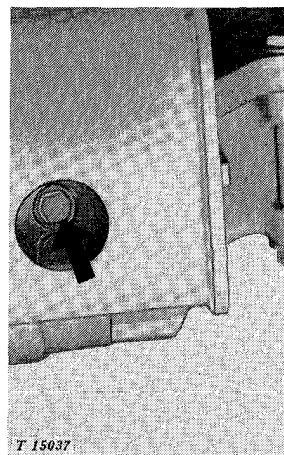

Fig. 10-Front Differential Check Plug

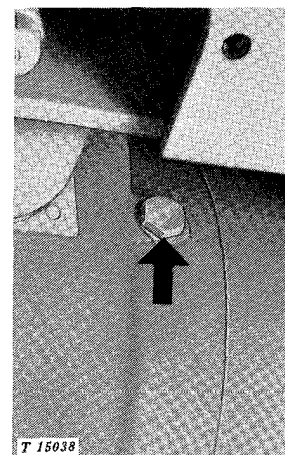

Fig. 11-Rear Differential Check Plug

Check oil level at oil level - filler plug on the side of the differential housings. Oil must be cold and loader must be on level ground. The oil level should be up to the plug. Add John Deere HY-GARD Oil or an equivalent, if necessary.

Differential oil levels checked _____ Yes No
 Oil added, if any _____ qts. (L)

12. Alternator-Fan Belt Tension



Fig. 12-Alternator-Fan Belt Adjustment

Check alternator belt tension using a deflection gauge. A force of 17 pounds (76 N) on the alternator belt midway between the pulleys should deflect the belt 0.25 inch (6.4 mm).

IMPORTANT: Do not pry on the rear alternator housing as this may damage the alternator.

Loosen alternator bracket and adjusting cap screws. Apply outward pressure to the front alternator frame. Adjust to desired tension. Tighten adjusting cap screws on alternator bracket.

When a belt tension gauge is used, the initial reading should be 130 to 140 pounds (579 to 623 N) strand tension. After 3 minutes of operation recheck belt tension. The gauge should read a minimum of 85 to 95 pounds (378 to 423 N) strand tension.

Check fan belt tension using a deflection gauge. A force of 20 pounds (89 N) on the fan belts midway between the pulleys should deflect the belts 0.75 inch (19 mm).

To adjust, turn the idler pulley adjusting screw to adjust tension on idler pulley. Tighten idler pulley adjusting screw.

When a belt tension gauge is used, the initial reading should be 95 to 105 pounds (423 to 467 N) strand tension. After 3 minutes of operation recheck belt tension. The gauge should read a minimum of 85 to 95 pounds (378 to 422 N) strand tension.

Alternator belt tension	_____lb. (kg) tension
	_____in. (mm) flex
Fan belt tension	_____lb. (kg) tension
	_____in. (mm) flex

13. Check Engine Speeds

Warm up engine and attach a tachometer to engine tachometer drive to check engine speeds.

No-load, fast idle speed should be 2375-2425 rpm. Slow idle should be 700 rpm.

If engine speeds need adjustment, see page 10-10-24.

Engine speeds checked	Yes No
-----------------------	--------

14. Check Lubrication

The loader was checked and lubricated before it left the factory. However, to insure customer satisfaction, check each lubrication point shown in the following pages. Lubricate with several strokes, if necessary.

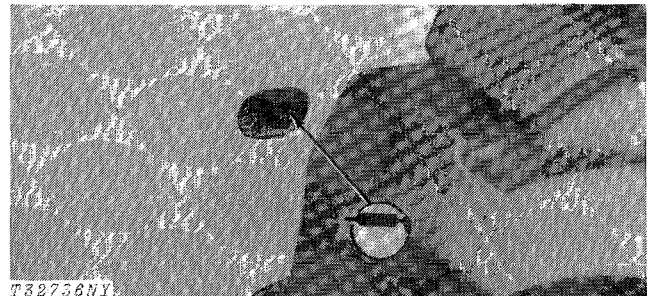

Fig. 13-Steering Cylinder Rear Pivot Pins (2 Points)

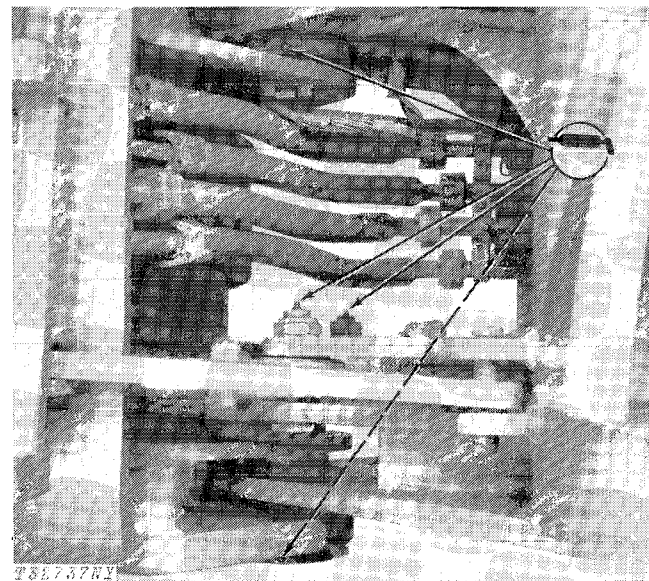

Fig. 14-Steering Cylinder Front Pivot Pins (2 Points) and Frame Hinge Pivots (2 Points)

Lubricant required	Yes No
--------------------	--------

Lubricate all pivot points in the linkage from the control lever to the control valves with engine oil.

Lubricant required	Yes No
--------------------	--------



Suggest:

If the above button click is invalid.

Please download this document

first, and then click the above link

to download the complete manual.

Thank you so much for reading

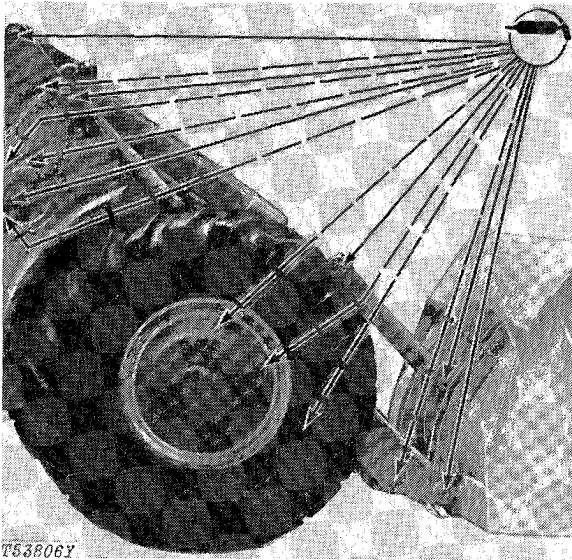

T53806Y

Fig. 15-Loader Boom and Bucket Cylinders and Pivots (14 Points)

Lubricant required Yes No

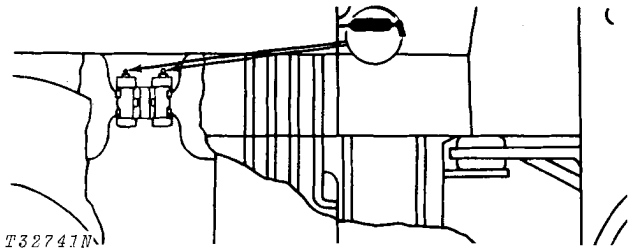

T32743N

Fig. 18-Engine-to-Transmission Universal Joint (2 Points)

Lubricant required Yes No

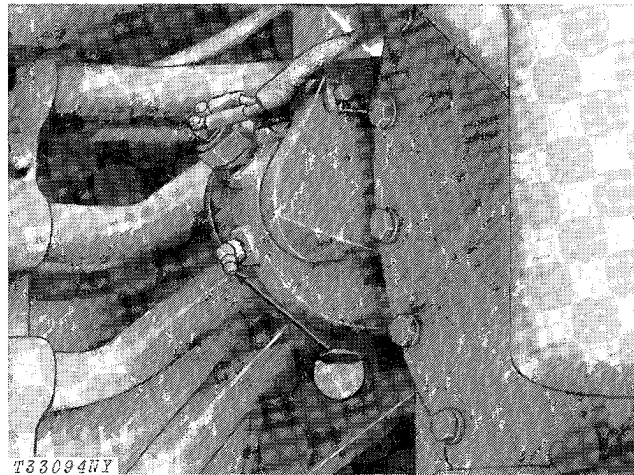

T33094NY

Fig. 19-Shift Control Bell Crank Fitting (1 Point)

Lubricant required Yes No

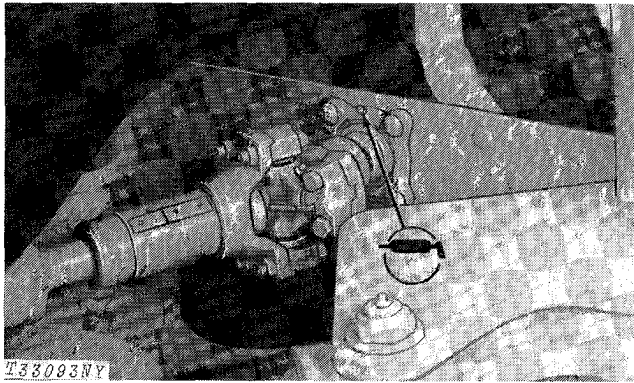

T33093NY

Fig. 16-Front Drive Shaft Support Bearing (1 Point)

Lubricant required Yes No

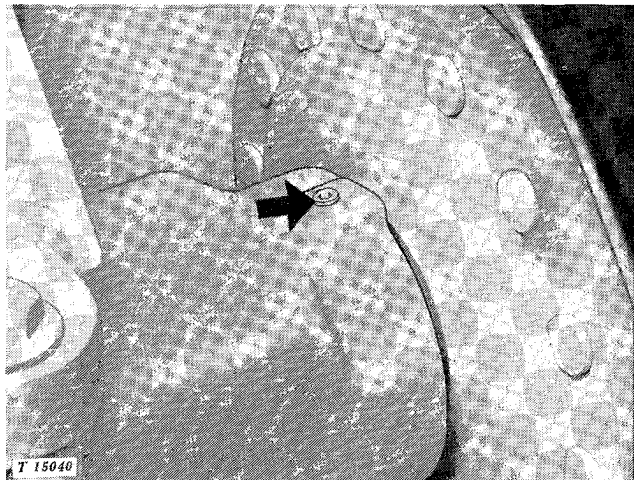

T 15040

Fig. 20-Axle Bearing Plug (Front Shown) (4 Points)

If lubrication is required, remove pipe plug in each wheel and install grease fittings. Reinstall pipe plug after greasing.

Lubricant required Yes No

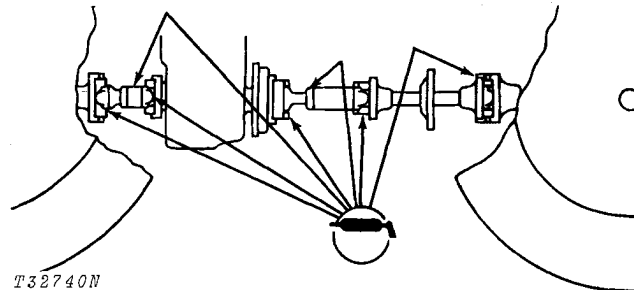

T32740N

Fig. 17-Transmission-to-Differential Drive Lines (7 Points)

Lubricant required Yes No

<https://www.ebooklibonline.com>

Hello dear friend!

Thank you very much for reading.

Enter the link into your browser.

The full manual is available for immediate download.

<https://www.ebooklibonline.com>