

**John Deere
595D
Excavator
Repair**

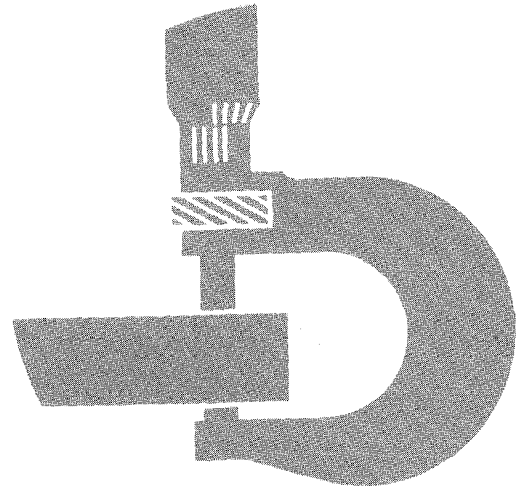

TECHNICAL MANUAL

TM-1445 (Feb-89)

LITHO IN U.S.A.

Introduction

FOREWORD

This manual is written for an experienced technician. Essential tools required in performing certain service work are identified in this manual and are recommended for use.

Live with safety: Read the safety messages in the introduction of this manual and the cautions presented throughout the text of the manual.



This is the safety-alert symbol. When you see this symbol on the machine or in this manual, be alert to the potential for personal injury.

Technical manuals are divided in two parts: repair and diagnostics. Repair sections tell how to repair the components. Diagnostic sections help you identify the majority of routine failures quickly.

Information is organized in groups for the various components requiring service instruction. At the beginning of each group are summary listings of all applicable essential tools, service equipment and tools, other materials needed to do the job, service parts kits, specifications, wear tolerances, and torque values.

Binders, binder labels, and tab sets can be ordered by John Deere dealers direct from the John Deere Distribution Service Center.

This manual is part of a total product support program.

FOS Manuals-reference

Technical Manuals-machine service

Component Manuals-component service

Fundamentals of Service (FOS) Manuals cover basic theory of operation, fundamentals of troubleshooting, general maintenance, and basic types of failures and their causes. FOS Manuals are for training new personnel and for reference by experienced technicians.

Technical Manuals are concise guides for specific machines. Technical manuals are on-the-job guides containing only the vital information needed for diagnosis, analysis, testing, and repair.

Component Technical Manuals are concise service guides for specific components. Component technical manuals are written as stand-alone manuals covering multiple machine applications.

595D EXCAVATOR TECHNICAL MANUAL TM-1445 (FEB-89)

SECTION AND GROUP CONTENTS

NOTE: This manual covers machine repair. For operation and tests information, see TM-1444.

SECTION I—GENERAL INFORMATION

- Group I—Safety
- Group II—General Specifications
- Group III—Torque Values
- Group IV—Fuels and Lubricants
- Group V—Inspection Procedures

SECTION 01—WHEELS

- Group 0110—Powered Wheels and Fastenings

SECTION 02—AXLES AND SUSPENSION SYSTEMS

- Group 0200—Removal and Installation
- Group 0210—Differential or Bevel Drive
- Group 0225—Input Drive Shafts and U-Joints
- Group 0250—Axle Shafts, Bearings and Reduction Gears
Tow Excavator, Hub Reduction,
Steering Knuckle, Front and Rear
Axle Housings

SECTION 03—TRANSMISSION

- Group 0300—Removal and Installation
- Group 0325—Input Drive Shafts and U-Joints
- Group 0350—Gears, Shafts, Bearings, and Power Shift Clutch
Transmission, 2WD-4WD
Shift Unit, Front Output Housing,
Bevel Gear Housing, and Pinion
Shaft
- Group 0360—Hydraulic System
Travel (Transmission Drive)
Motor, Counterbalance Valve, and
Rotary Manifold

SECTION 04—ENGINE

NOTE: For engine, 4.5L (276 cu in.), repair, see CTM-4.

- Group 0400—Removal and Installation
Engine, Fuel Injection Pump, Fuel
Injection Nozzles, Bleed Fuel
System, Turbocharger, Fuel
Transfer Pump, Water Pump,
Intake Manifold, Exhaust Manifold
and Engine Oil Cooler

SECTION 05—ENGINE AUXILIARY SYSTEMS

- Group 0505—Cold Weather Starting Aids
Starting Aid Solenoid, Nozzle and
Engine Coolant Heater
- Group 0510—Cooling System
Fan, Fan Belt and Radiator
- Group 0515—Speed Controls
Speed Control Assembly and
Linkage
- Group 0520—Intake System
Air Cleaner and Air Intake System
Leakage Test
- Group 0560—External Fuel Supply System

SECTION 07—DAMPENER DRIVE (FLEX COUPLING)

- Group 0752—Elements

SECTION 09—STEERING SYSTEM

- Group 0960—Hydraulic System
Steering Valve, Pump, Flow
Regulator, Switch Valve and
Cylinder

Continued on next page

All information, illustrations and specifications contained in this technical manual are based on the latest information available at the time of publication. The right is reserved to make changes at any time without notice.

COPYRIGHT© 1989
DEERE & COMPANY
Moline, Illinois
All rights reserved
A John Deere ILLUSTRATION™ Manual

TX,1445 CC1 240389

<https://www.ebooklibonline.com>

Hello dear friend!

Thank you very much for reading.

Enter the link into your browser.

The full manual is available for immediate download.

<https://www.ebooklibonline.com>

SECTION 10—SERVICE BRAKES

- Group 1011—Active Elements
- Group 1060—Hydraulic System

SECTION 11—PARK BRAKE

- Group 1111—Active Elements

SECTION 16—ELECTRICAL SYSTEM

- Group 1671—Batteries, Support and Cables
- Group 1672—Alternator, Regulator and Charging System Wiring
- Group 1674—Wiring Harness and Switches
- Group 1676—Instruments and Indicators
- Group 1677—Motors and Actuators
 - Starting Motor

SECTION 17—FRAME, CHASSIS, OR SUPPORTING STRUCTURE

- Group 1740—Frame Installation
- Group 1749—Chassis Weights

SECTION 18—OPERATOR'S STATION

- Group 1800—Removal and Installation
 - Cab (Without Floor)
- Group 1810—Operator Enclosure
 - Window Panes, Cab Door and Latch, Door Release Handle, Windshield Washer and Wiper
- Group 1821—Seat
- Group 1830—Heater and Air Conditioning

SECTION 19—SHEET METAL AND STYLING

- Group 1910—Hood or Engine Enclosure

SECTION 20—SAFETY, CONVENIENCE, AND MISCELLANEOUS

- Group 2004—Horn and Warning Devices

SECTION 22—PNEUMATIC SYSTEM

- Group 2261—Pump and Drives
 - Air Compressor, Idle Pulley
- Group 2262—Control Valves
 - Control Valves, Relief Valves
- Group 2264—Reservoir, Filter, and Trap
 - Air Dryer, Air Horn

SECTION 32—BULLDOZERS

- Group 3200—Removal and Installation
- Group 3260—Hydraulic System

SECTION 33—EXCAVATOR

- Group 3302—Buckets
 - Bucket, Linkage, Bushings, Tooth Tip and Tooth Shank
- Group 3340—Frames
 - Arm, Boom and Bushings
- Group 3360—Hydraulic System
 - Hydraulic Pump, Hydraulic Pump Regulator, Pilot Pump, Solenoid Valve and Pilot Pressure Regulating Valve, Engine Speed Mode Selection Cylinders, Hydraulic Control Valve, Reservoir, Return Filter and Suction Filter, Oil Cooler Restriction Valve, Oil Cooler Bypass Valve, Oil Cooler, Cylinders, Propel Function Pilot Controller Valve, Dig Function Pilot Controller Valve, Pilot Shut-off Valve, Pilot Filter, Flow Control Valve and Check Valve Block

SECTION 43—SWING, ROTATION, OR PIVOTING SYSTEM

- Group 4311—Brakes
- Group 4350—Mechanical Drive Elements
 - Swing Gearbox and Swing Bearing
- Group 4360—Hydraulic System
 - Swing Motor, Crossover Relief Valves, Make-up Valves and Swing Brake Release Valve

SECTION 99—DEALER FABRICATED TOOLS

- Group 9900—Dealer Fabricated Tools

TX,1445 CC2 240389

HANDLE FLUIDS SAFELY—AVOID FIRES

When you work around fuel, do not smoke or work near heaters or other fire hazards.

Store flammable fluids away from fire hazards. Do not incinerate or puncture pressurized containers.

Make sure machine is clean of trash, grease, and debris.

Do not store oily rags; they can ignite and burn spontaneously.



AB6;TS227 053;FLAME 050188

PREVENT BATTERY EXPLOSIONS

Keep sparks, lighted matches, and open flame away from the top of battery. Battery gas can explode.

Never check battery charge by placing a metal object across the posts. Use a volt-meter or hydrometer.

Do not charge a frozen battery; it may explode. Warm battery to 16°C (60°F).



AB6;TS204 053;SPARKS 280688

PREPARE FOR EMERGENCIES

Be prepared if a fire starts.

Keep a first aid kit and fire extinguisher handy.

Keep emergency numbers for doctors, ambulance service, hospital, and fire department near your telephone.

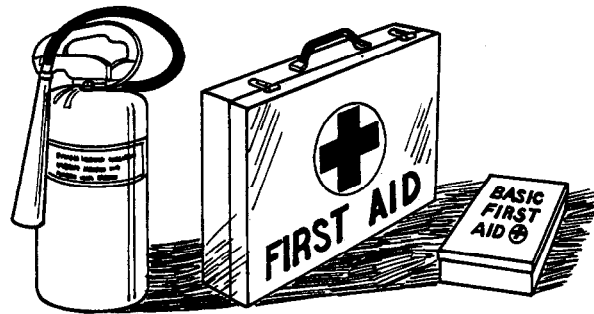

AB6;TS186 053;FIRE2 080785

PREVENT ACID BURNS

Sulfuric acid in battery electrolyte is poisonous. It is strong enough to burn skin, eat holes in clothing, and cause blindness if splashed into eyes.

Avoid the hazard by:

1. Filling batteries in a well-ventilated area.
2. Wearing eye protection and rubber gloves.
3. Avoiding breathing fumes when electrolyte is added.
4. Avoiding spilling or dripping electrolyte.
5. Use proper jump start procedure.

If you spill acid on yourself:

1. Flush your skin with water.
2. Apply baking soda or lime to help neutralize the acid.
3. Flush your eyes with water for 10-15 minutes. Get medical attention immediately.

If acid is swallowed:

1. Drink large amounts of water or milk.
2. Then drink milk of magnesia, beaten eggs, or vegetable oil.
3. Get medical attention immediately.

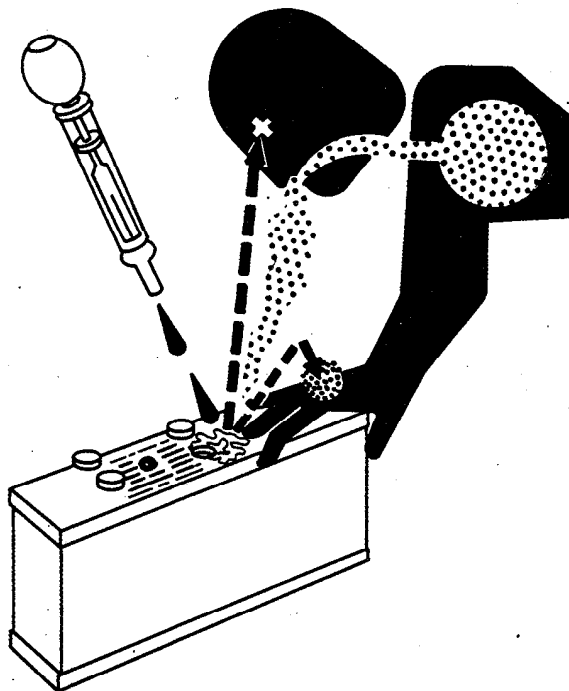

AB6;TS203 053;POISON 211287

AVOID HIGH-PRESSURE FLUIDS

Escaping fluid under pressure can penetrate the skin causing serious injury. Relieve pressure before unhooking hydraulic or other lines. Tighten all connections before applying pressure. Keep hands and body away from pinholes and nozzles which eject fluids under high pressure. Use a piece of cardboard to search for leaks.

If ANY fluid is injected into the skin, it must be surgically removed within a few hours by a doctor familiar with this type injury or gangrene may result.

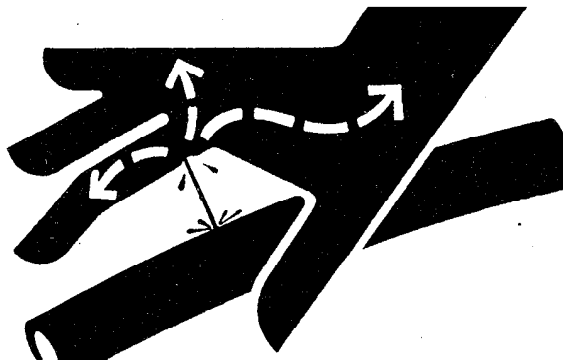

AB6;X9811 053;FLUID 180987

PARK MACHINE SAFELY

Before working on the machine:

- Lower all equipment to the ground.
- Stop the engine and remove the key.
- Disconnect the battery ground strap.
- Hang a "DO NOT OPERATE" tag in operator station.

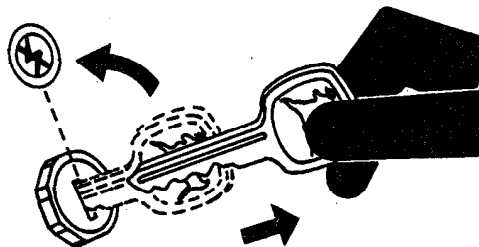

AB6;TS230 053;PARK 050188

SUPPORT MACHINE PROPERLY

Always lower the attachment or implement to the ground before you work on the machine. If you must work on a lifted machine or attachment, securely support the machine or attachment.

Do not support the machine on cinder blocks, hollow tiles, or props that may crumble under continuous load. Do not work under a machine that is supported solely by a jack. Follow recommended procedures in this manual.

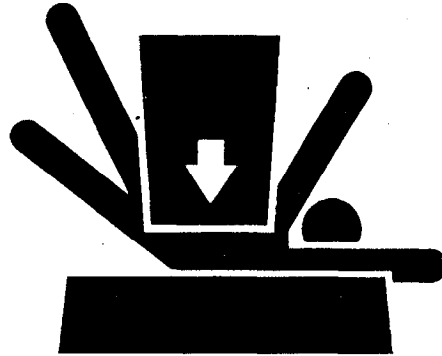

AB6;TS229 053;LOWER 211287

WEAR PROTECTIVE CLOTHING

Wear close fitting clothing and safety equipment appropriate to the job.

Prolonged exposure to loud noise can cause impairment or loss of hearing.

Wear a suitable hearing protective device such as earmuffs or earplugs to protect against objectionable or uncomfortable loud noises.

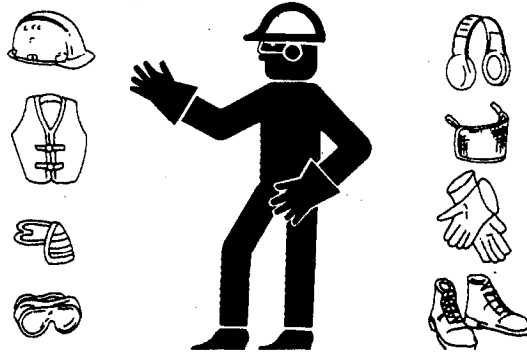

AB6;TS206 053;WEAR 230487

SERVICE MACHINE SAFELY

Tie long hair behind your head. Do not wear a necktie, scarf, loose clothing, or necklace when you work near machine tools or moving parts. If these items were to get caught, severe injury could result.

Remove rings and other jewelry to prevent electrical shorts and entanglement in moving parts.

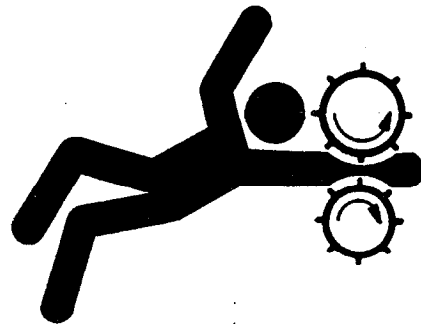

AB6;TS228 053;LOOSE 211287

WORK IN VENTILATED AREA

Engine exhaust fumes can cause sickness or death. If it is necessary to run an engine in an enclosed area, remove the exhaust fumes from the area with an exhaust pipe extension.

If you do not have an exhaust pipe extension, open the doors and get outside air into the area.

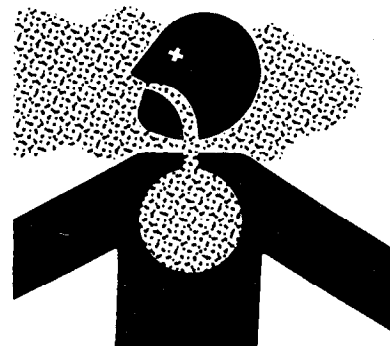

AB6;TS220 053;AIR 050188

SERVICE EQUIPMENT AND TOOLS

NOTE: Order tools from your SERVICE-GARD™ Catalog. Some tools may be available from a local supplier.

Name	Use
Spring Scale	To measure bearing rolling drag torque

TX,0210 CC31 281088

OTHER MATERIALS

Number	Name	Use
TY9371	Thread Lock and Sealer (High Strength)	Ring gear cap screws
TY6304	Flexible Sealant	Carrier to axle housing

TX,0210 CC32 281088

SPECIFICATIONS

Item	Measurement	Specification
Carrier and Differential Assembly	Approximate Weight	73 kg (160 lb)
Differential Pinion to Spider	Clearance	0.1 mm (0.004 in.)
	Wear Limit	0.2 mm (0.008 in.)
Gear to Differential Housing	Clearance	0.03 mm (0.0012 in.)
	Wear Limit	0.09 mm (0.0035 in.)
Pinion Shaft Bearing Preload	Force	37.3—44.1 N (8.4—9.9 lb force)
Ring Gear-to-Differential Housing Cap Screws	Torque	208 N·m (153 lb-ft)
Differential Housing-to-Differential Housing Cap Screw and Nut	Torque	151 N·m (112 lb-ft)
Gear to Differential Housing	Clearance	0.03—0.09 mm (0.001—0.003 in.)
Bearing Cap-to-Carrier Cap Screws	Torque	151 N·m (112 lb-ft)
Bearing Adjusting Nuts	Torque	47 N·m (35 lb-ft)
Ring Gear and Differential Housing Bearings Preload	Force	23.5—27.5 N (5.3—6.2 lb force)
Ring Gear	Runout	0.00—0.09 mm (0.000—0.0035 in.)
	Service Limit	0.02 mm (0.008 in.)
Pinion Housing-to-Carrier Cap Screws	Torque	79 N·m (59 lb-ft)
Ring Gear-to-Pinion Shaft Backlash	Clearance	0.25—0.33 mm (0.010—0.013 in.)
Carrier-to-Axle Housing Cap Screws	Torque	48 N·m (36 lb-ft)

TX,0210 CC33 281088

REMOVE AND INSTALL DIFFERENTIAL

1. Remove drain plug (A) to drain oil. Approximate capacity for front axle is 6.9 L (7.3 qt) or rear axle is 10.2 L (10.6 qt).
2. Loosen level plug (B) to speed draining.

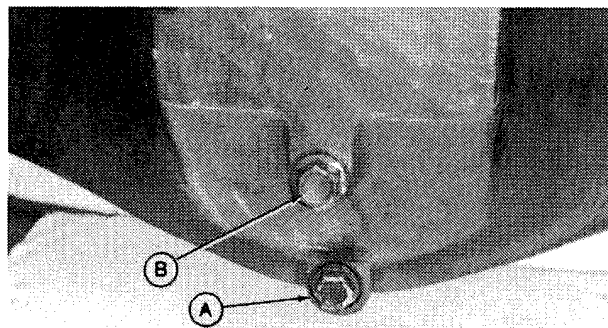

6AG:T6460FS TX,0210 CC1 281088

3. Remove knuckle and axle shafts.(See procedure in Group 0250.)



CAUTION: The approximate weight of carrier and differential assembly is 73 kg (160 lb).

4. Remove cap screws and lock washers (A) to remove carrier and differential assembly.

Install cap screws in tapped holes (B) to help separate carrier from axle housing.

5. Make repairs as necessary. (See procedure in this group.)

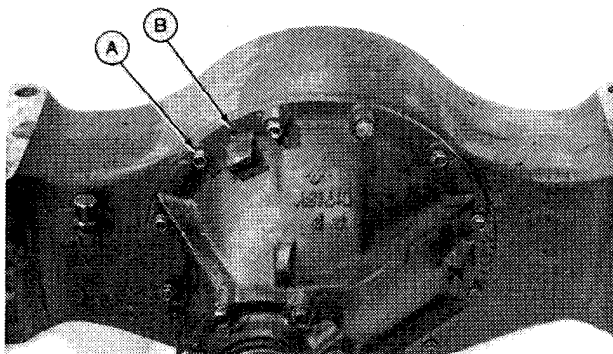

6AG;T6878EK TX,0210 CC2 281088

6. Before installing the differential, clean the machined surfaces of axle housing and carrier.

Apply a bead of flexible sealant to surface.

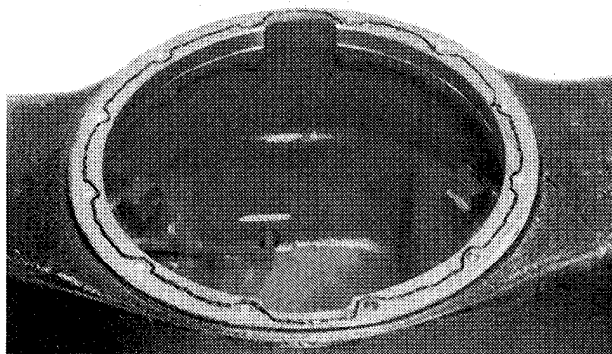

6AG;T6460GM TX,0210 CC3 281088

7. Install carrier and differential assembly, cap screws, and lock washers. Tighten cap screws to 48 N·m (36 lb-ft).

8. Install axle and knuckle assembly.

9. Fill planetary cases and axle housing to level plug with specified oil. (See Swing Gearbox, Transmission, Axles, and Wheel Gear Reduction Oil in Section I, Group IV.)

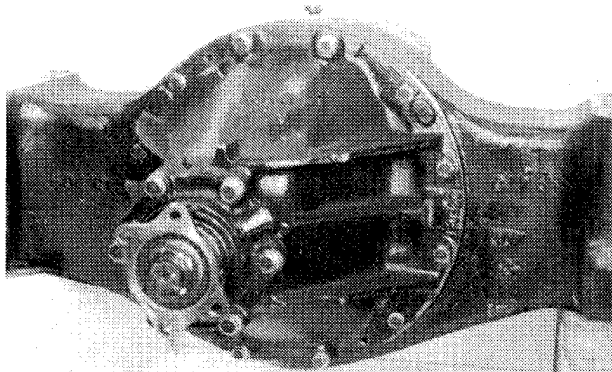

6AG;T6460GN TX,0210 CC4 281088

DISASSEMBLE DIFFERENTIAL

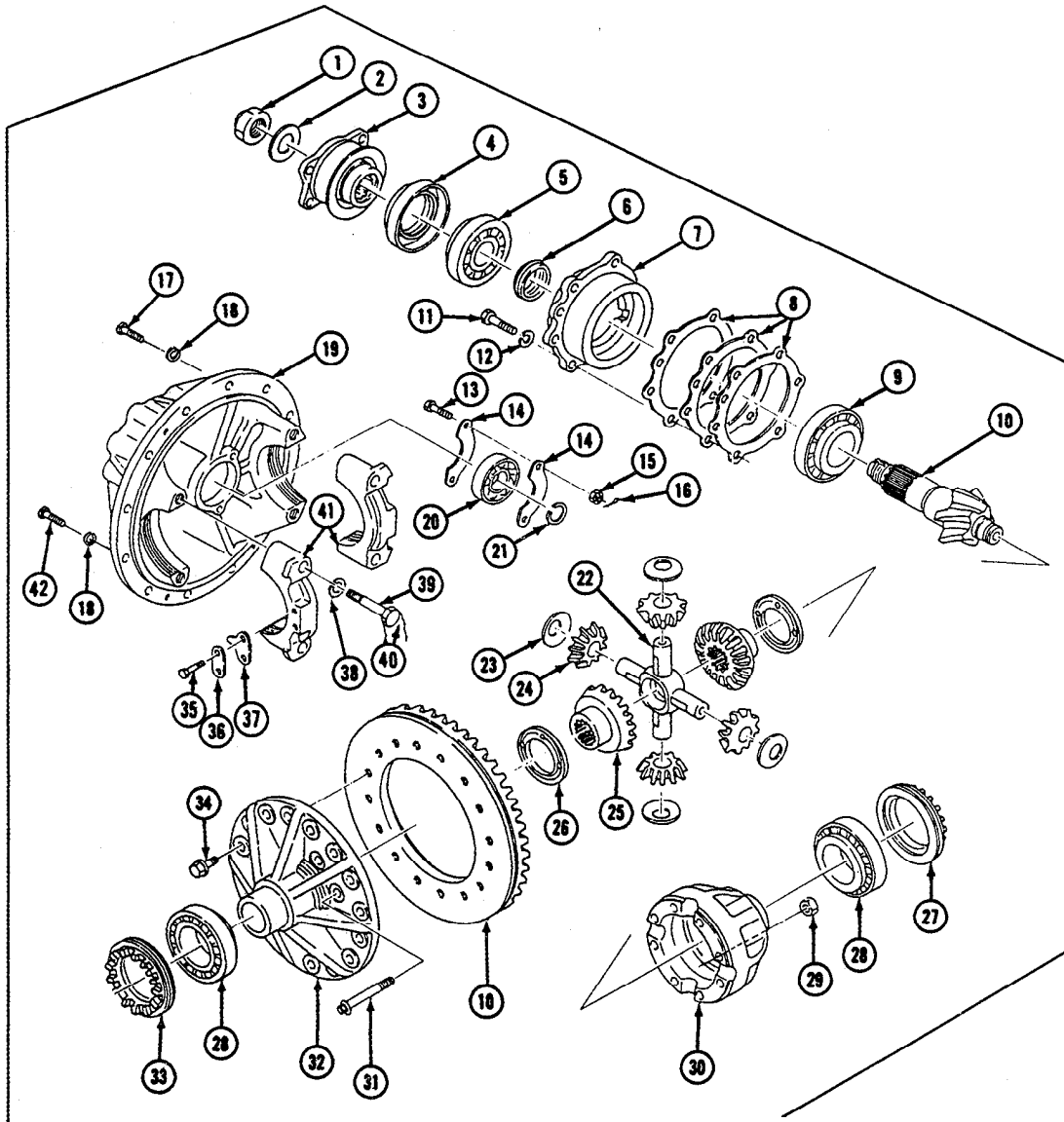

- | | | | |
|-------------------------------|--------------------------|---------------------------|-------------------------|
| 1—Lock Nut | 12—Lock Washer (6 used) | 23—Thrust Washer (4 used) | 33—Adjusting Nut |
| 2—Washer | 13—Cap Screw (2 used) | 24—Pinion (4 used) | 34—Cap Screw (16 used) |
| 3—Flange | 14—Retainer (2 used) | 25—Gear (2 used) | 35—Cap Screw (4 used) |
| 4—Oil Seal | 15—Nut (2 used) | 26—Washer | 36—Strap (2 used) |
| 5—Bearing Cone And Cup | 16—Cotter Pin (2 used) | 27—Adjusting Nut | 37—Plate (2 used) |
| 6—Spacer | 17—Cap Screw (4 used) | 28—Bearing (2 used) | 38—Lock Washer (4 used) |
| 7—Cage | 18—Lock Washer (12 used) | 29—Nut (8 used) | 39—Cap Screw (4 used) |
| 8—Shim | 19—Carrier | 30—Differential Housing | 40—Wire (2 used) |
| 9—Bearing Cone And Cup | 20—Bearing | 31—Cap Screw (8 used) | 41—Caps (8 used) |
| 10—Ring Gear And Pinion Shaft | 21—Snap Ring | 32—Differential Housing | 42—Cap Screw (8 used) |
| 11—Cap Screw (6 used) | 22—Spider | | |

Differential or Bevel Drive/Differential

1. Remove cap screws and lock washers (A) to remove pinion shaft and housing.

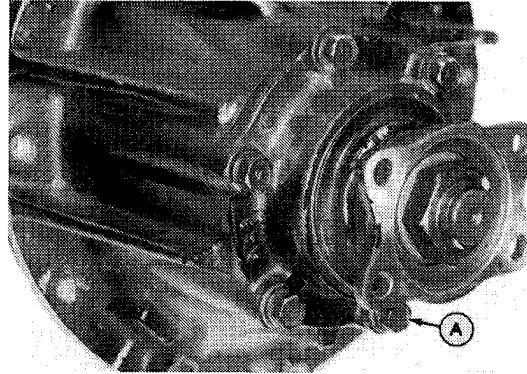

6AG;T6460FU TX,0210 CC6 281088

2. Make punch marks (A) on bearing caps, carrier, and adjusting nuts to aid installation.

3. Remove cap screws (B) to remove lock plate (C).

- A—Punch Marks
- B—Cap Screws (4 used)
- C—Lock Plate (2 used)
- D—Plate (2 used)

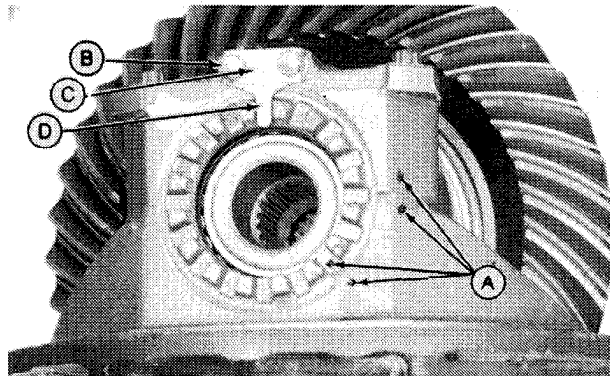

6AG;T6460FV TX,0210 CC7 281088



CAUTION: The approximate weight of ring gear and differential is 34 kg (75 lb).

4. Remove cap screws (A) and bearing caps (B) to remove ring gear and differential.

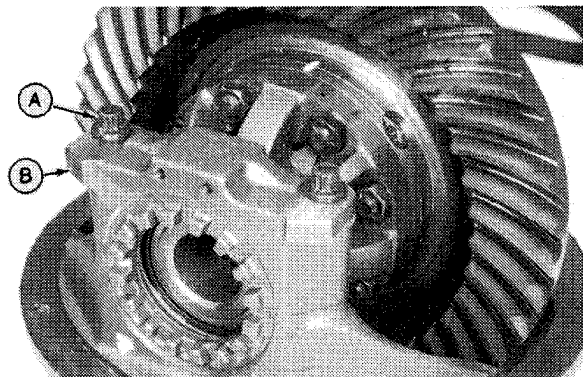

6AG;T6460FW TX,0210 CC8 281088

5. Remove parts (A—D) to remove bearing (E).

- A—Cotter Pin (2 used)
- B—Nut (2 used)
- C—Cap Screw (2 used)
- D—Retainer (2 used)
- E—Bearing

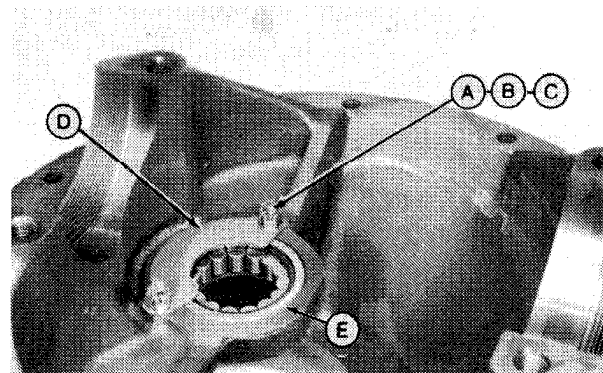

6AG;T6460FX TX,0210 CC9 281088

Differential or Bevel Drive/Differential

6. Bend out tops on lock nut (A). Remove lock nut, washer (B), and flange (C).

7. Tap on pinion shaft to remove from housing. Remove spacer, oil seal, and bearings.

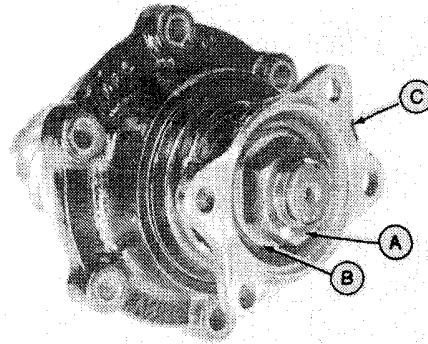

6AG;T6460FZ TX,0210 CC10 281088

8. Make an index mark (A) to aid assembly.

9. Remove nuts (B) to remove differential housing (C).

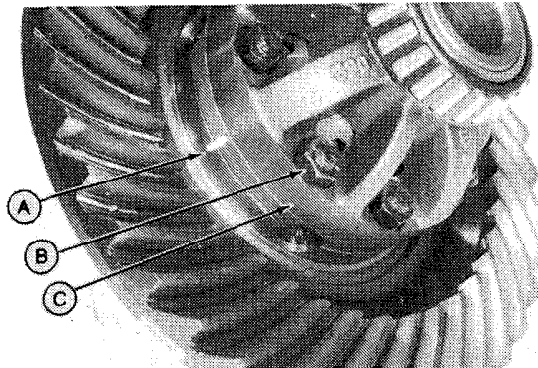

6AG;T6460FY TX,0210 CC11 281088

10. Remove parts (A—D).

A—Thrust Washer (2 used)
B—Gear (2 used)
C—Pinion (4 used)
D—Washer (4 used)

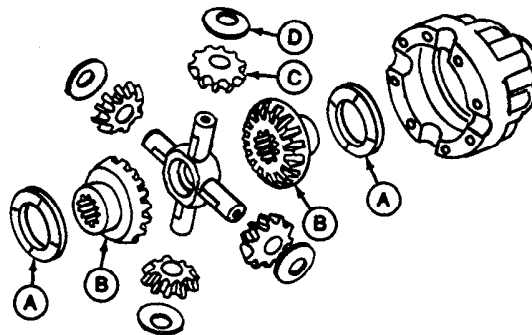

6AG;T6534AA TX,0210 CC12 281088

11. Remove cap screws (A) if ring gear and pinion shaft are being replaced.

12. Remove bearings from differential housings if replacement is necessary.

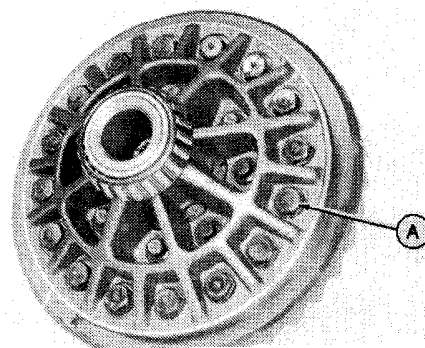

6AG;T6460GB TX,0210 CC13 281088

13. Inspect all parts for wear, damage, and abnormal condition.

14. Measure I.D. of pinions and O.D. of spider.

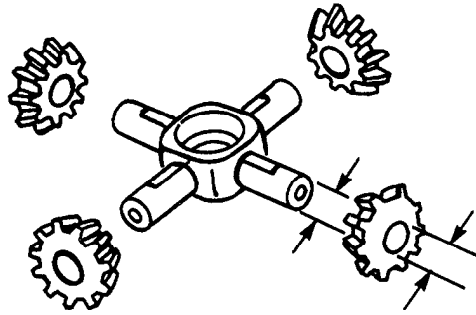

CLEARANCE SPECIFICATIONS

Gear-to-Shaft 0.1 mm (0.004 in.)

Wear Limit 0.2 mm (0.008 in.)

6AG;T6460GC TX,0210 CC14 281088

15. Measure I.D. of differential housing and O.D. of gear.

CLEARANCE SPECIFICATIONS

Gear-to-Differential Housing 0.03 mm (0.0012 in.)

Wear Limit 0.09 mm (0.0035 in.)

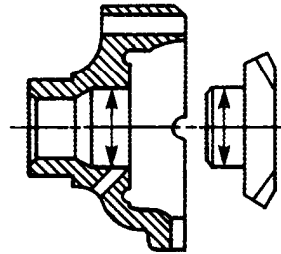

6AG;T6460GD TX,0210 CC15 281088

ASSEMBLE DIFFERENTIAL

1. Install bearing cup (A) in pinion housing.
 2. Install bearing cones (B) on pinion shaft and in housing.
 3. Apply a flexible sealant to oil seal O.D. Install seal in housing with lip (spring side) towards inside of housing. Apply petroleum jelly to lip of seal.
 4. Install a new spacer (C).
- Install inner race and snap ring (D).

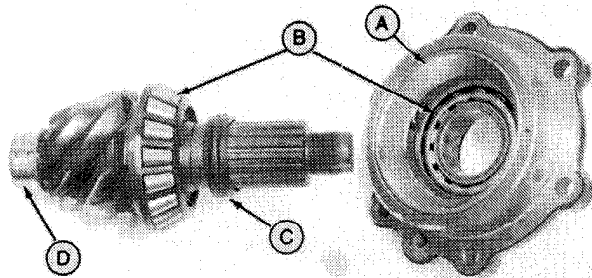

6AG;T6460GE TX,0210 CC16 281088

Differential or Bevel Drive/Differential

5. Install pinion shaft into housing. Install flange (C), washer (B), and lock nut (A).

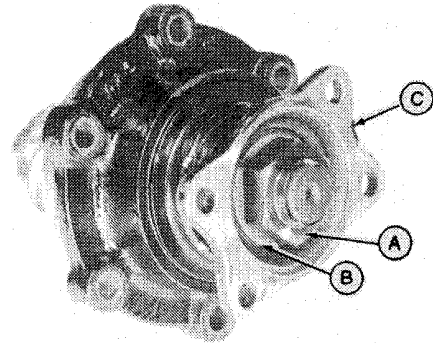

6AG;T6460FZ TX,0210 CC17 281088

6. Tighten lock nut until bearing preload (measured as shown) is within specifications.

SPECIFICATIONS

Bearing Preload 37.3—44.1N (8.4—9.9 lb force)

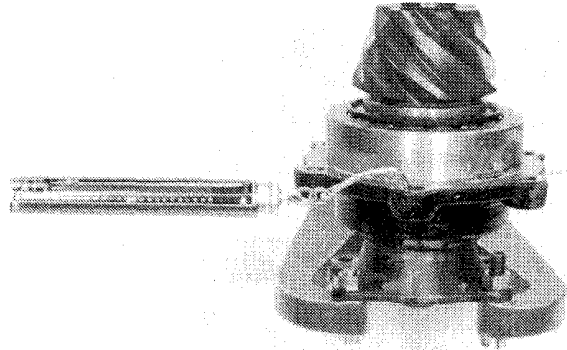

6AG;T6460GF TX,0210 CC18 281088

7. Stake lock nut in two places.

8. Install ring gear.

9. Apply thread lock and sealer (high strength) to threads of cap screws (A). Tighten cap screws to 28 N·m (153 lb-ft).

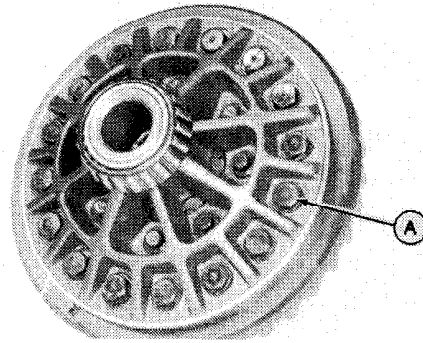

6AG;T6460GB TX,0210 CC19 281088

10. Install thrust washer (A) and gear (B) in differential housing.

11. Install pinions (C) and thrust washers (D) on spider. Install assembly in differential housing.

- A—Thrust Washer (2 used)
- B—Gears (2 used)
- C—Pinions (4 used)
- D—Thrust Washer (4 used)

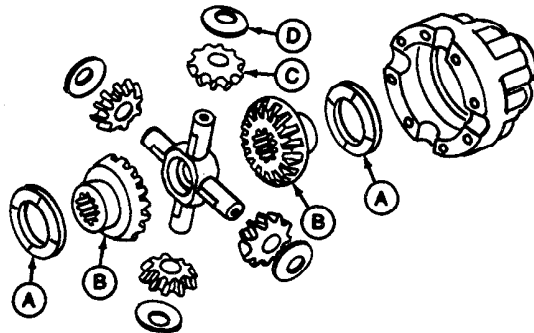

6AG;T6534AA TX,0210 CC20 281088

12. Install differential housing (C) on ring gear differential housing aligning index marks (A). Install cap screws and nuts (B). Tighten nuts (B) to 151 N·m (112 lb-ft).

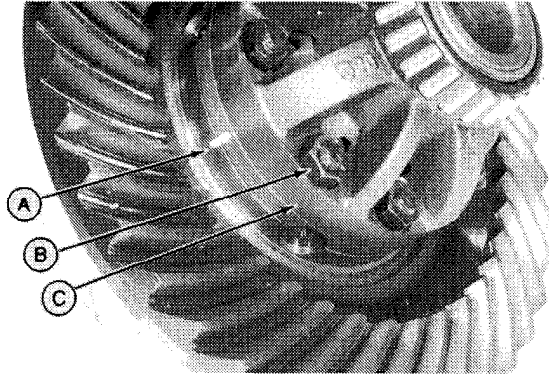

6AG;T6460FY TX,0210 CC21 311088

13. Measure clearance between gear and differential housing on both sides.

SPECIFICATIONS

Clearance 0.03—0.09 mm (0.001—0.003 in.)

Adjust clearance on each side using a thrust washer of a different thickness. Seven different thicknesses are available.

14. Stake nuts (A) in two places.

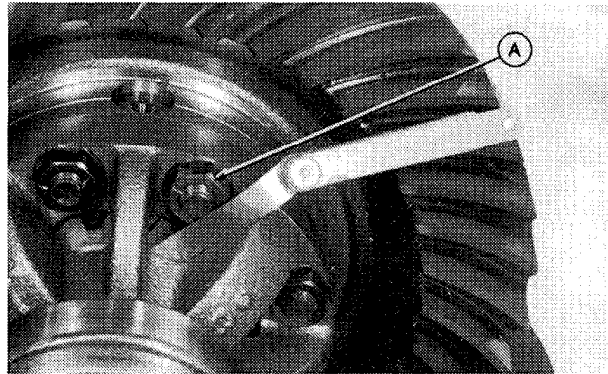

6AG;T6460GG TX,0210 CC22 311088

15. Install bearing cones (A). Push cones tight against shoulder.

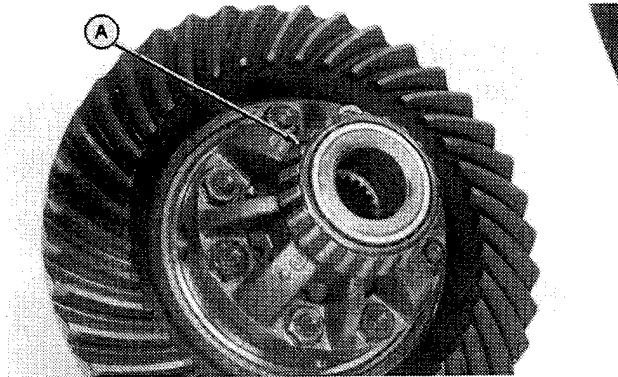

6AG;T6460GH TX,0210 CC23 311088

16. Install bearing (E) and parts (A—D).

- A—Cotter Pin (2 used)
- B—Nut (2 used)
- C—Cap Screw (2 used)
- D—Retainer (2 used)
- E—Bearing

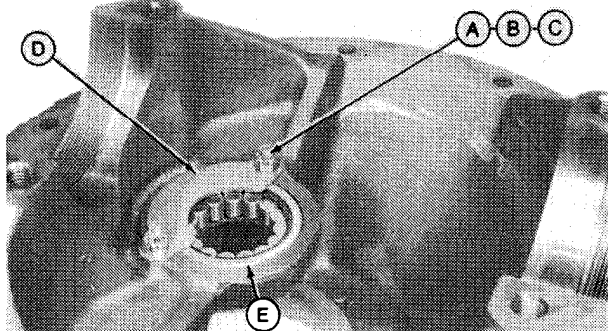

6AG;T6460FX TX,0210 CC24 311088

17. Install bearing cups on cones then install ring gear and differential into carrier. Install adjusting nuts (A).

18. Align punch marks (B) (applied at disassembly). Install bearing caps and cap screws. Tighten cap screws to 151 N·m (112 lb-ft).

19. Tighten adjusting nuts to 47 N·m (35 lb-ft).

20. Measure bearing preload at a ring gear cap screw as shown.

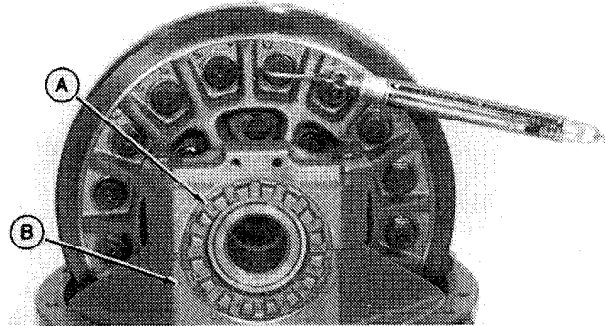

SPECIFICATIONS

Bearing Preload 23.5—27.5 N (5.3—6.2 lb force)

6AG;T6460GI TX,0210 CC25 311088

21. Rotate ring gear and measure axial run-out.

SPECIFICATIONS

Axial Run-Out 0.09 mm (0.0035 in.)
Service Limit 0.2 mm (0.008 in.)

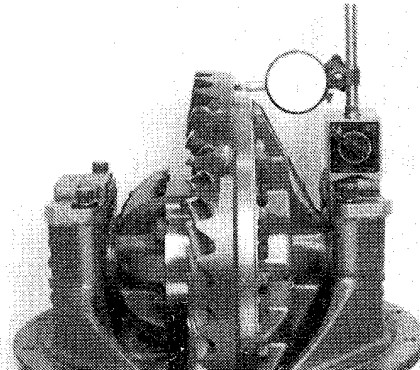

6AG;T6460GJ TX,0210 CC26 311088

22. Install pinion housing and shims on carrier. Align oil passage in pinion housing and shims with passage in carrier. Install and tighten cap screws (A).

TORQUE SPECIFICATION

Pinion Housing-to-Carrier Cap Screws 79 N·m (59 lb-ft)

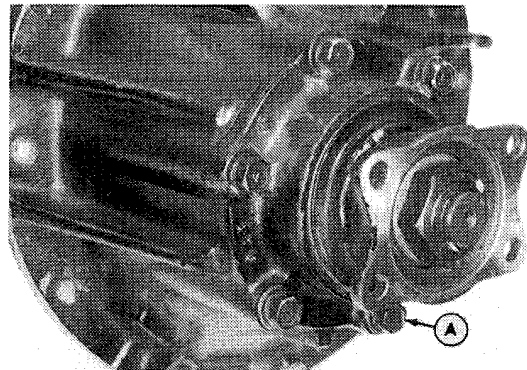

6AG;T6460FU TX,0210 CC27 311088

23. Measure ring gear backlash at gear tooth (A) at four different positions. Take an average of the measurements.

SPECIFICATIONS

Ring Gear Backlash 0.25—0.33 mm (0.010—0.013 in.)

Turn one adjusting nut in and the opposite nut out the same amount to get the specified backlash and to maintain previously adjusted bearing preload.

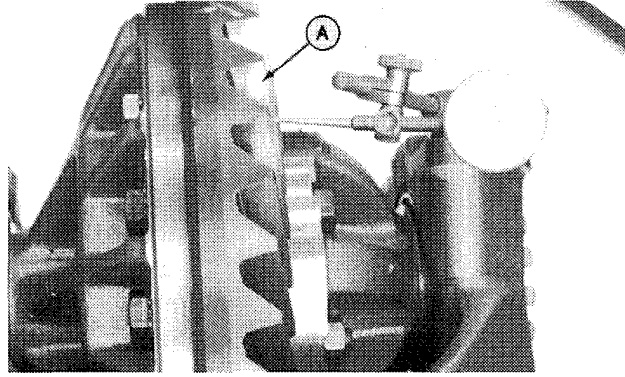

6AG:T6460GK TX,0210 CC28 311088

24. Check bearing pattern by putting a dye on several ring gear teeth that will show the tooth contact pattern.

Hold ring gear to retard movement and turn pinion shaft in normal direction of rotation for one complete revolution of ring gear.

25. Check tooth contact pattern on ring gear and adjust cone point as necessary.

Pattern too close to end of pinion—add shims between pinion housing and carrier.

Pattern too far from end of pinion—remove shims between pinion housing and carrier.

26. Check backlash after adjusting cone point.

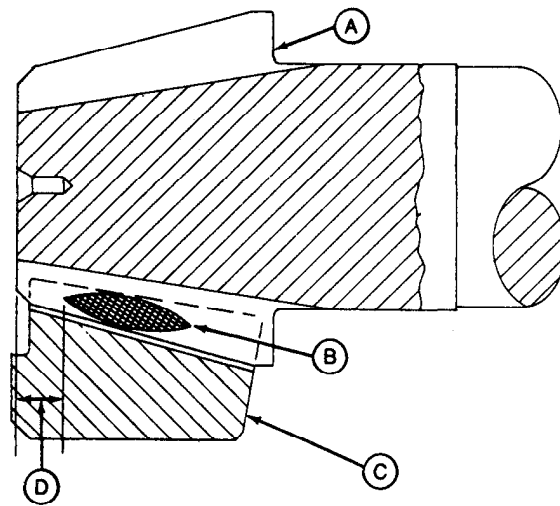

A—Pinion Shaft Tooth
B—Tooth Pattern
C—Ring Gear Tooth
D—5 mm (0.20 in.)

6AG:T94315 TX,0210 CC29 311088

27. When correct contact pattern and backlash has been obtained, install plate (A), lock plate (B), and cap screw (C).

28. Tighten cap screws. Bend end of lock plate against one flat of cap screw head.

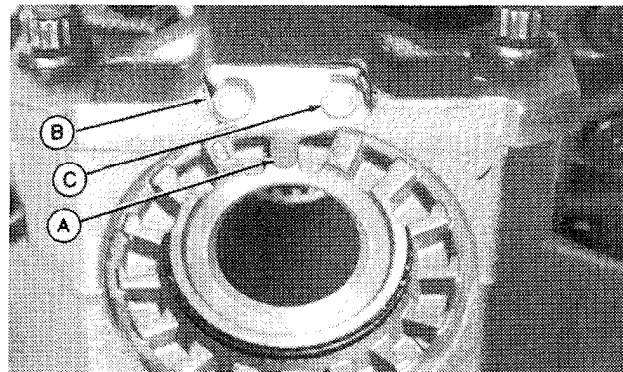

6AG:T6460GL TX,0210 CC30 311088

OTHER MATERIALS

Number	Name	Use
T43512	Thread Lock and Sealer (Medium Strength)	Drive shaft cap screws and studs

TX,0225 CC1 311088

SPECIFICATIONS

Item	Measurement	Specification
Drive Shaft-to-Axle Cap Screws and Nuts	Torque	76 N·m (56 lb-ft)

TX,0225 CC2 311088

REMOVE AND INSTALL FRONT DRIVE SHAFT

1. Secure drive shaft (A) to undercarriage using chain or lifting strap.
2. Remove cap screws, lock washers, and nuts (B) to remove drive shaft.
3. Install drive shaft. Tighten nuts (B) to 76 N·m (56 lb-ft).

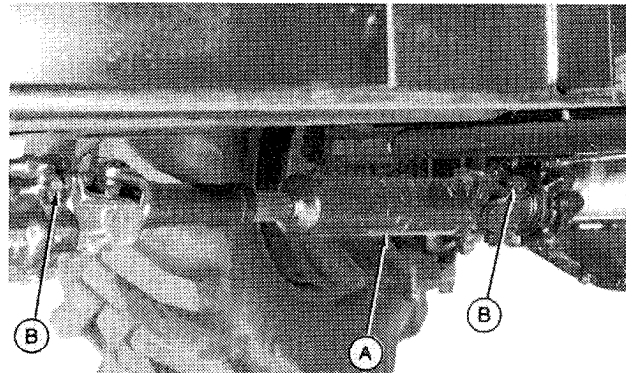

7AG;T6878CE TX,0225 CC3 311088

REMOVE AND INSTALL REAR DRIVE SHAFT

1. Secure drive shaft (A) to undercarriage using chain or lifting strap.
2. Remove cap screws, nuts, and lock washers (B and C) to remove drive shaft.
3. Install drive shaft. Tighten nuts (B and C) to 76 N·m (56 lb-ft).

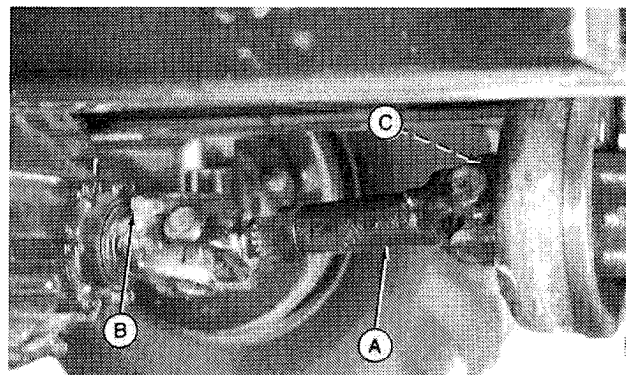

7AG;T6878CF TX,0225 CC4 311088

DISASSEMBLE AND ASSEMBLE FRONT DRIVE SHAFT

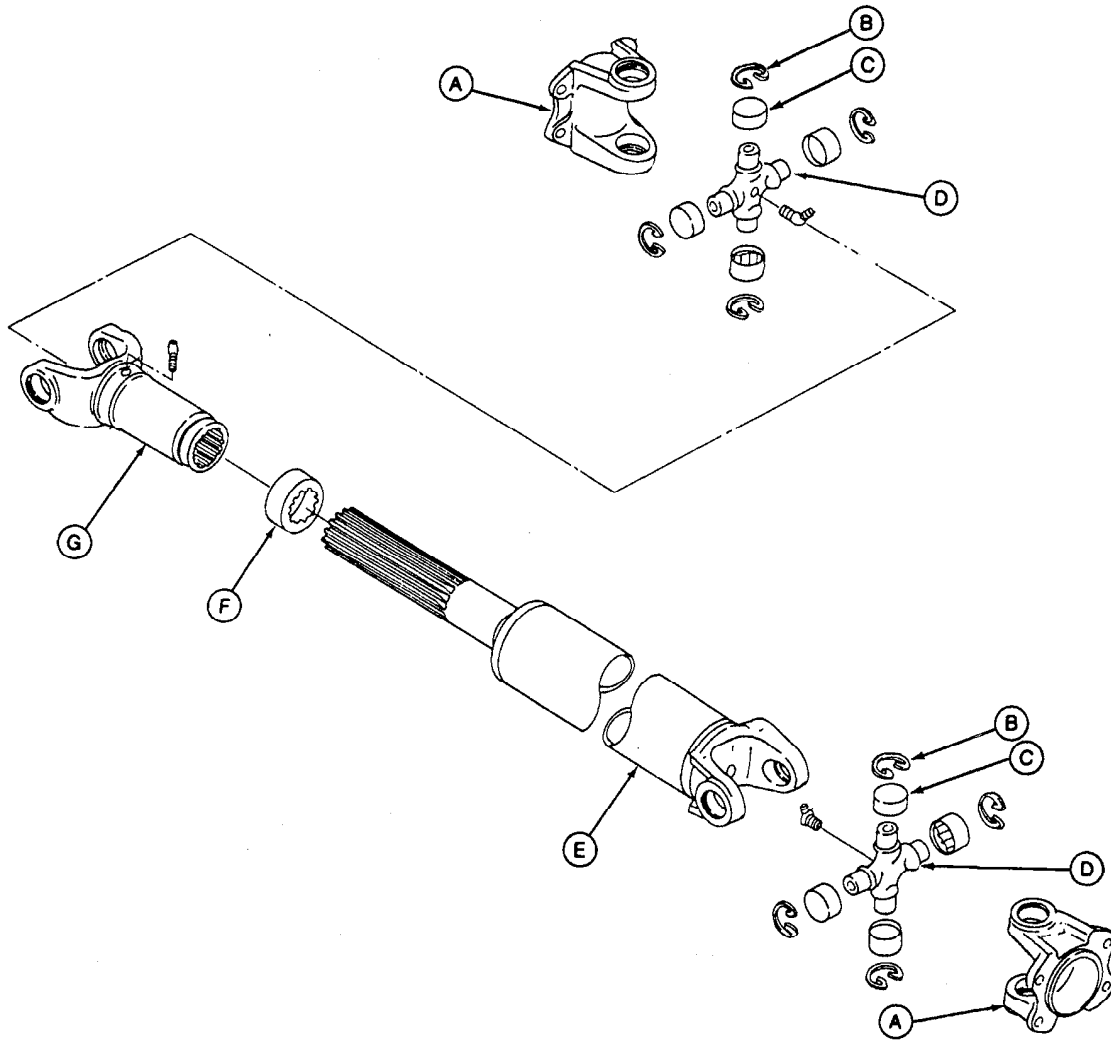

A—Yoke
B—Snap Ring

C—Bearing
D—Spider

E—Tube
F—Seal

G—Yoke

Lubricate drive shaft (3 points). (See Grease in Section I, Group IV for grease recommendations.)

7AG:T6878BX TX,0225 CCS 311088



Suggest:

If the above button click is invalid.

Please download this document first, and then click the above link to download the complete manual.

Thank you so much for reading

DISASSEMBLE AND ASSEMBLE REAR DRIVE SHAFT

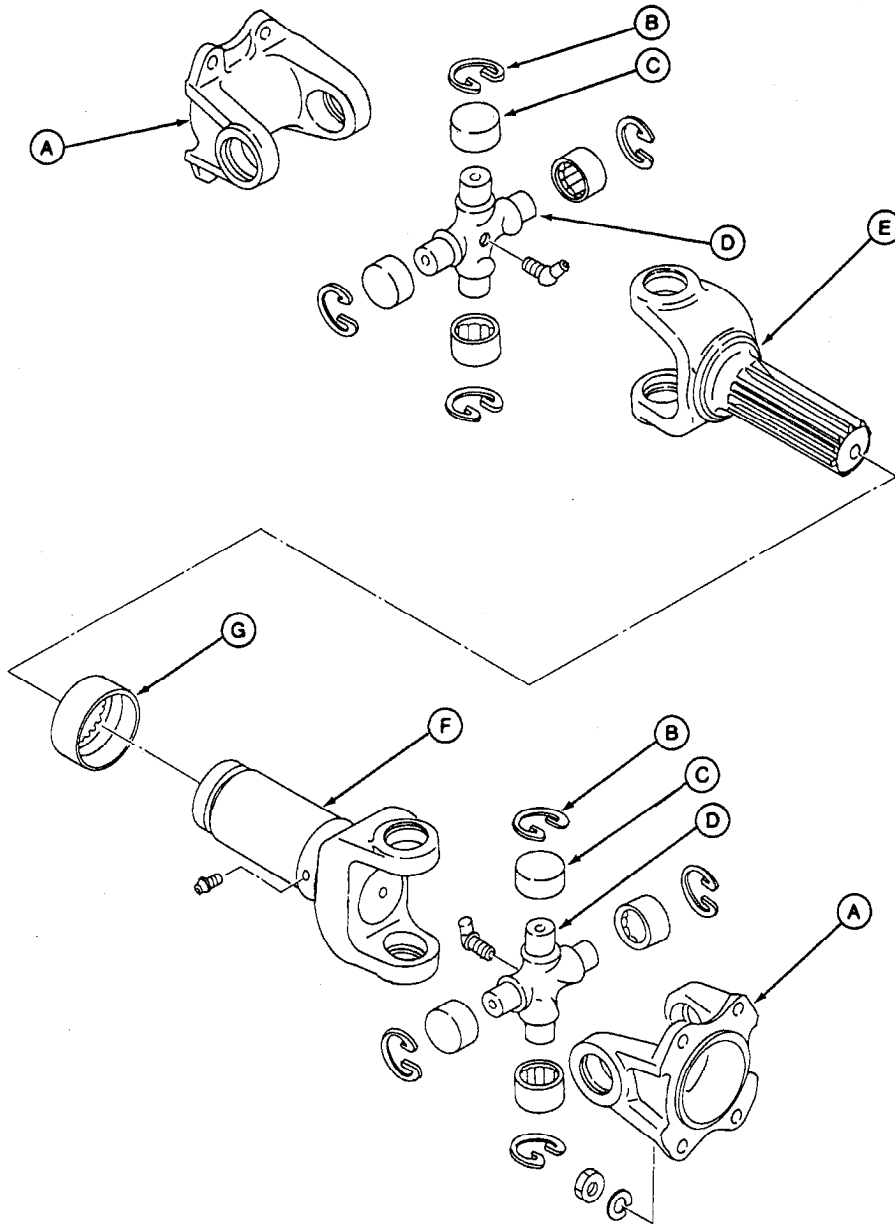

A—Yoke
B—Snap Ring

C—Bearing
D—Spider

E—Yoke
F—Yoke

G—Seal

Lubricate drive shaft (three points) following assembly. (See Grease in Section I, Group IV for grease recommendations.)

<https://www.ebooklibonline.com>

Hello dear friend!

Thank you very much for reading.

Enter the link into your browser.

The full manual is available for immediate download.

<https://www.ebooklibonline.com>