

# John Deere JD544 and JD544-A Loaders

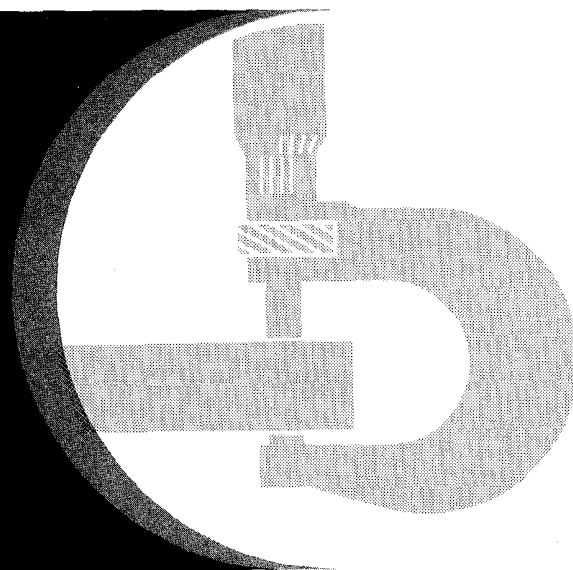

## Technical Manual

John Deere Dubuque Works  
TM-1002 (May-80)



LITHO IN U.S.A.

# JD544 AND JD544-A LOADERS

TECHNICAL MANUAL

TM-1002 (Apr-74)

## CONTENTS

### Section 10—GENERAL

- Group 5 Specifications
- Group 10 Predelivery, Delivery, and After-Sales Services
- Group 15 Tune-up and Adjustment
- Group 20 Lubrication
- Group 25 Loader Separation

### Section 20—ENGINE

- Group 5 Diagnosis
- Group 10 Basic Engine
- Group 15 Engine Lubrication
- Group 20 Speed Control Linkage
- Group 25 Engine Cooling
- Group 30 Specifications and Special Tools

### Section 30—FUEL SYSTEM

- Group 5 Diagnosis
- Group 10 Tank, Filters, and Transfer Pump
- Group 15 Air Intake System
- Group 20 Fuel Injection Pump  
Fuel Injection Nozzles (see SM-2045)

### Section 40—ELECTRICAL SYSTEM

- Group 5 Wiring Diagrams
- Group 10 Charging System
- Group 15 Starting Circuit
- Group 20 Gauges and Switches

### Section 50—POWER TRAIN

- Group 5 Damper and Drive Shafts
- Group 10 Transmission Assembly
- Group 11 Disconnect Output Shaft
- Group 15 Axle Assemblies
- Group 20 Differentials

### Section 60—POWER STEERING AND BRAKE SYSTEMS

- Group 5 General Information, Testing, and Diagnosis
- Group 10 Hydraulic Pump (3.01 cu. in.)
- Group 15 Filters, Cooler, and Accumulators
- Group 20 Steering System
- Group 25 Brake System

### Section 70—HYDRAULIC SYSTEM

- Group 5 General Information, Testing, and Diagnosis
- Group 10 Reservoir and Filters
- Group 15 Hydraulic Pump
- Group 20 Control Valve
- Group 25 Return-to-Dig Valve
- Group 30 Backhoe Control Valve
- Group 35 Cylinders
- Group 40 Backhoe Swing Cylinder

### Section 80—MISCELLANEOUS COMPONENTS

- Group 5 Frames
- Group 10 Buckets
- Group 15 Drott 4-in-1 Buckets
- Group 20 9305 Backhoe
- Group 25 Specifications and Special Tools

## INDEX

*The specifications and design information contained in this manual were correct at the time it was printed. It is John Deere's policy to continually improve and update our machines. Therefore, the specifications and design information are subject to change without notice. Wherever applicable, specifications and design information are in accordance with SAE and IEMC standards.*

Copyright 1967  
DEERE & COMPANY  
Moline, Illinois  
All rights reserved

## INTRODUCTION

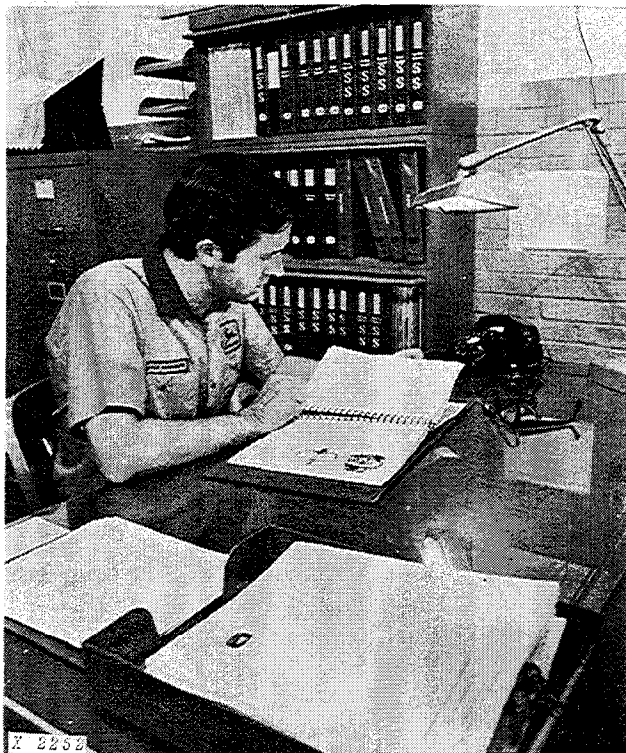

Use FOS Manuals for Reference

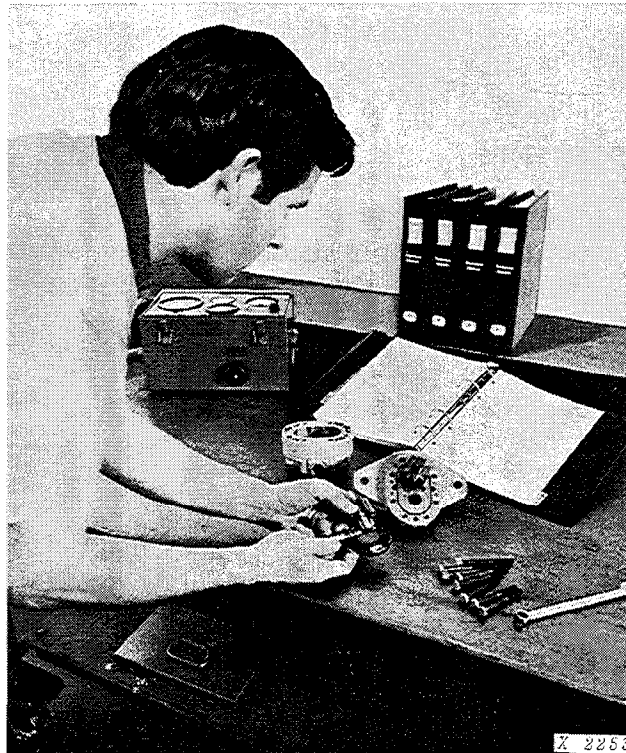

Use Technical Manuals for Actual Service

This technical manual is part of a twin concept of service:

- **FOS Manuals—for reference**
- **Technical Manuals—for actual service**

The two kinds of manuals work as a team to give you both the general background and technical details of shop service.

*Fundamentals of Service (FOS) Manuals* cover basic theory of operation, *fundamentals* of trouble shooting, *general* maintenance, and *basic* types of failures and their causes. FOS Manuals are for training new men and for reference by experienced men.

*Technical Manuals* are concise service guides for a *specific* machine. Technical Manuals are on-the-job guides containing only the vital information needed by a journeyman mechanic.



When a serviceman should refer to a FOS Manual for more information, a FOS symbol like the one at the left is used in the TM to identify the reference.

Some features of this technical manual:

- *Table of contents at front of manual*
- *Exploded views showing parts relationship*
- *Photos showing service techniques*
- *Specifications grouped for easy reference*

This technical manual was planned and written for you—a journeyman mechanic. Keep it in a permanent binder in the shop where it is handy. Refer to it whenever in doubt about correct service procedures or specifications.

Using the technical manual as a guide will reduce error and costly delay. It will also assure you the best in finished service work.



This safety alert symbol identifies important safety messages in this manual. When you see this symbol, be alert to the possibility of personal injury and carefully read the message that follows.

**<https://www.ebooklibonline.com>**

Hello dear friend!

Thank you very much for reading.

Enter the link into your browser.

The full manual is available for immediate download.

**<https://www.ebooklibonline.com>**



TRAVEL SPEEDS (with 17.5-25 Tires)

Shift Lever Position	Speed
Low (L)	0 to 7 mph
High (H)	0 to 23 mph
Reverse (R)	0 to 9 mph

DIFFERENTIALS

Front . . . . . Standard or optional "No Spin"  
Rear . . . . . Standard

DRIVE AXLES

Four-wheel drive with inboard mounted planetary gears on both axles.  
Front . . . . . Fixed  
Rear . . . . . Oscillating (11° from horizontal)

LOADER HYDRAULIC SYSTEM

Type . . . . . Open center, constant volume system to operate loader boom and bucket  
Pump . . . . . Transmission-mounted, vane type

TIRE OPTIONS

13.00 - 24, 10 PLY RATING (Grader Tread)  
14.00 - 24, 12 PLY RATING (Grader Tread)  
15.5 - 25, 10 PLY RATING (Loader Tread)  
15.5 - 25, 12 PLY RATING (Loader Tread) (Early Models)  
17.5 - 25, 12 PLY RATING (Loader Tread)  
14.00 - 24, 12 PLY RATING (Rock Grader) (Early Models)  
17.5 - 25, 16 PLY RATING (Rock Tread)

POWER STEERING AND BRAKES HYDRAULIC SYSTEM

Type . . . . . Closed center, constant pressure system. Includes power steering, power brakes, and transmission cooling.  
Pump . . . . . Engine-driven eight-piston pump.

STEERING

Full power steering.  
Frame steered by two hydraulic cylinders.  
Frame pivot from center. . . . . 40°  
Clearance circle . . . . . 32 ft.  
Turning radius . . . . . 13 ft. 10 in.

BRAKES

Hydraulic power-operated, inboard-mounted disk type brake for each wheel. Brake pedal control of transmission clutches.  
Mechanical 10 x 1-1/2-inch expanding shoe parking brake on transmission output shaft.

CAPACITIES (U.S. Standard Measures)

Fuel tank . . . . . 40 gal.  
Cooling system . . . . . 7-1/2 gal.  
Engine crankcase . . . . . 12 qt.  
Transmission (includes steering and brakes hydraulic system). . . . . 10 gal. (approx.)  
Transmission case and filters (after initial fill) . . . . . 9-3/4 gal. (approx.)  
Front differential  
"No Spin" option . . . . . 4-1/4 gal.  
Regular . . . . . 4-3/4 gal.  
Rear differential. . . . . 4-3/4 gal.  
Loader hydraulic sump. . . . . 12 gal.  
Loader hydraulic system (sump, lines, and cylinders). . . . . 21 gal.

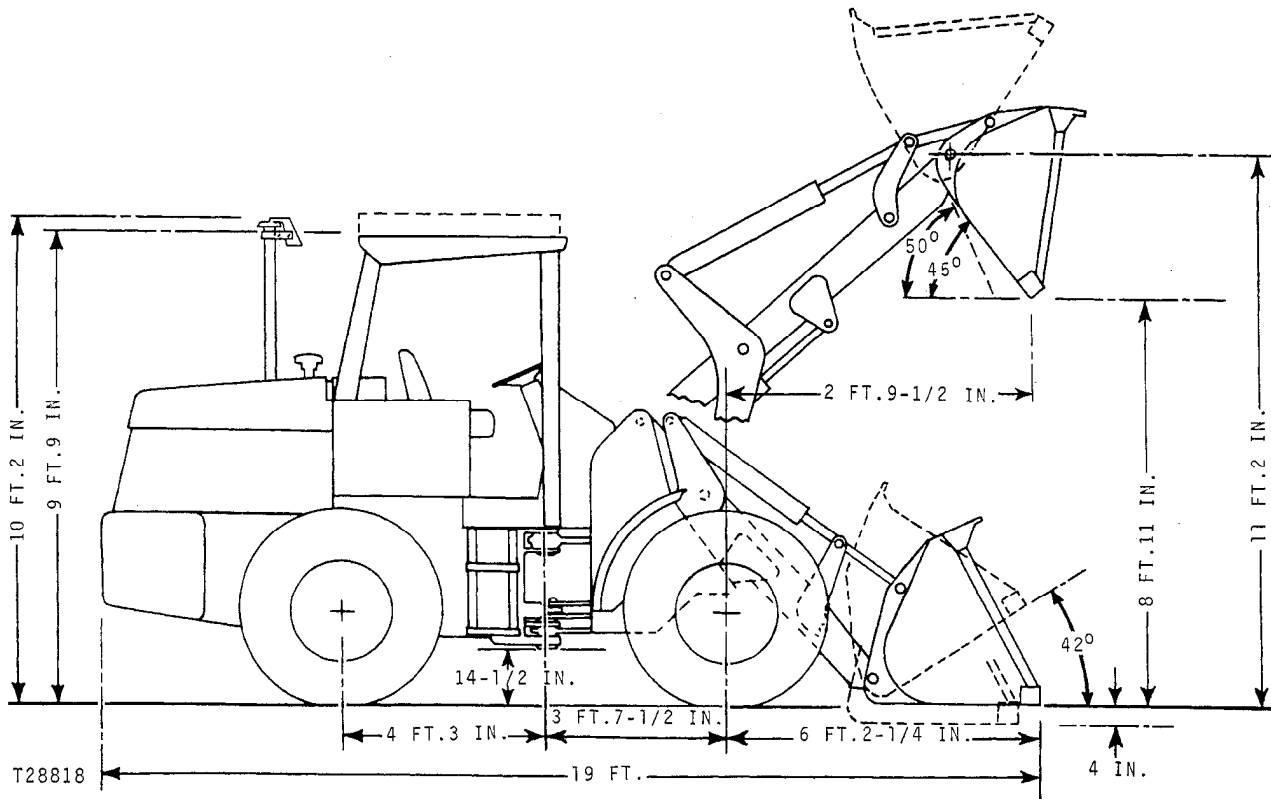

Fig. 1-Loader Dimensions

**LOADER DIMENSIONS** (with 17.5-25 tires and 1-1/2 yd. Bucket)

Overall height (to top of Cab) . . . . .	10 ft. 2 in.
Height to top of canopy . . . . .	9 ft. 9 in.
Overall width . . . . .	7 ft. 4 in.
Overall length (bucket level, no bucket teeth) . . . . .	19 ft.
Ground clearance . . . . .	14-1/2 in.
Wheel base . . . . .	7 ft. 10-1/2 in.
Maximum bucket dump angle (full height) . . . . .	50°
Dumping reach (full height) (bucket at 45° angle) . . . . .	2 ft. 9-1/2 in.
Dumping clearance (full height) (bucket at 45° angle) . . . . .	8 ft. 11 in.
Maximum lift (bucket at full height) (at pivot pin) . . . . .	11 ft. 2 in.
Digging depth below ground (bucket level) . . . . .	4 in.

<b>Bucket breakout force (SAE)</b>	
1-1/2 yd. . . . .	16,105 lbs.
1-3/4 yd. . . . .	14,875 lbs.
2 yd. . . . .	14,260 lbs.
3 yd. . . . .	10,650 lbs.
<b>Bucket width (1-1/2 yd.) . . . . .</b>	<b>7 ft. 4 in.</b>
(1-3/4 yd.) . . . . .	7 ft. 8 in.
(2 yd.) . . . . .	8 ft.
(3 yd.) . . . . .	8 ft.
Drott-4-in-1 . . . . .	8 ft.
Bucket roll-back (ground level) . . . . .	42°
Bucket reach (bucket on ground). . . . .	6 ft. 2-3/4 in.
Operating weight (with cab) . . . . .	20,430 lbs.

**LOADER OPERATING INFORMATION**

Bucket capacities 1-1/2, 1-3/4, 2 or 3 cu. yd.	
Lift (full height) . . . . .	8374 lbs.
Raising Time . . . . .	5.7 sec.
Lower Time (power down) . . . . .	4.5 sec.
Dumping Time . . . . .	1.6 sec.

(Specifications and design subject to change without notice. Whenever applicable, specifications are in accordance with IEMC and SAE Standards)

LOG AND LUMBER FORK

Lift capacity (full height stability limited)  
(with two sets side counterweights)  
Fork with single clamp . . . . . 10,040 lbs.  
Fork with double clamp . . . . . 9,792 lbs.  
Basic lumber fork . . . . . 11,410 lbs.  
Maximum clamp diameter . . . . . 9 ft. 1/2 in.  
Minimum clamp diameter . . . . . 28 in.  
Length of tines (heel-to-toe) . . . . . 4 ft.  
Maximum tine width (center-to-center) . . . . . 5 ft. 11 in.  
Minimum tine width (center-to-center) . . . . . 15 in.  
Raising time . . . . . 5.7 sec.  
Lowering time (power down) . . . . . 4.5 sec.  
Dumping time . . . . . 1.6 sec.  
Maximum unloading (dump) angle.. .40 degrees

9305 BACKHOE

Bucket retract . . . . . 2.0 sec.  
Bucket extend . . . . . 3.0 sec.  
Digging depth (IEMC) . . . . . 13 ft. 5 in.  
Digging force . . . . . 10,500 lbs.  
Reach from center of swing mast.. 17 ft. 1 in.  
Transport height . . . . . 12 ft. 1 in.  
Stabilizer width  
Transport . . . . . 7 ft. 3 in.  
Operating position (IEMC) . . . . . 8 ft. 7 in.

LOG LOADER

Fork capacity (8-foot wood) . . . . . 0.9 cord  
Lift capacity (with two sets side counterweights)  
(full height stability limited) . . . . . 9290 lbs. |  
Maximum clamp diameter . . . . . 6 ft. 2 in. |  
Minimum clamp diameter . . . . . 15-3/8 in. |  
Length of tines (heel-to-toe) . . . . . 4 ft. 2 in. |  
Tines width (center-to-center) . . . . . 5 ft. |  
Raising time . . . . . 5.5 sec. |  
Lowering time (power down) . . . . . 4.5 sec. |  
Dumping time . . . . . 1.2 sec. |  
Maximum unloading (dump) angle.. 40 degrees |

## Group 10

# PREDELIVERY, DELIVERY, AND AFTER-SALES SERVICES

### PREDELIVERY SERVICE

Because of the shipping factors involved, plus extra finishing touches that are necessary to promote customer satisfaction, proper delivery service is of prime importance to the dealer.

A tag pointing out the factory-recommended procedure for predelivery service is attached to each new loader before it leaves the factory.

After completing the factory recommended dealer checks and services listed on the predelivery tag, remove the tag from the loader and file it with the job shop order. The tag will then serve as a basis for certifying that the loader has received the proper predelivery service when the section of the customer's John Deere Delivery Receipt is completed.

### TEMPORARY LOADER STORAGE

Service	Specifications	Reference
Check radiator for coolant loss and anti-freeze protection.	Midway between radiator core and filler neck.	-----
Reduce shipping pressure of tires.	-----	Operator's Manual
Check crankcase oil level and fill fuel tank.	-----	Operator's Manual
Relieve hydraulic pressure.	Stop engine, lower bucket to ground, operate control levers and steering wheel to relieve pressure.	-----
Cover loader and tires for protection and cleanliness.	-----	-----

### BEFORE DELIVERING LOADER

#### COOLING SYSTEM

Inspect radiator for coolant loss.	Midway between radiator core and filler neck.	-----
------------------------------------	-----------------------------------------------	-------

Check anti-freeze protection.	-----	-----
-------------------------------	-------	-------

#### ELECTRICAL SYSTEM

Inspect battery electrolyte	-----	Operator's Manual
-----------------------------	-------	-------------------

Charge batteries, if required.	-----	FOS 20 - ELECTRICAL SYSTEMS
--------------------------------	-------	-----------------------------

Punch date code on battery tag.	-----	-----
---------------------------------	-------	-------

**BEFORE DELIVERING LOADER - Continued**

Service	Specifications	Reference
Check battery terminals to be sure they are tight.	-----	-----
Remove brake fuse from spare fuse holder and insert into fuse block. Test brake lights.	-----	-----
<b>LUBRICATION</b>		
Check crankcase oil level.	Between marks on dipstick.	Operator's Manual.
Check loader hydraulic system oil level.	Check oil level at window (JD303 Special-Purpose oil).	Operator's Manual.
Check front and rear differential oil levels.	To level of check plug (cold) (JD303 Special-Purpose oil).	Operator's Manual.
Check transmission oil level.	To top mark on dipstick (J. D. Torque Converter Fluid type C-2)	Operator's Manual.
Lubricate grease fittings.	John Deere Multi-Purpose Lubricant or an equivalent.	Operator's Manual.
<b>ENGINE</b>		
Check air cleaner.	-----	Operator's Manual.
Fill fuel tank and start engine.	40 U.S. gallons.	Operator's Manual.
Check operation of lights, gauges and indicator lights.	-----	Operator's Manual.
Check speed control linkage.	-----	Section 20, Group 20.
Check engine speeds.	-----	Section 20, Group 20.
<b>OPERATION</b>		
Shift transmission through all ranges.	-----	Operator's Manual.
Check loader hydraulic system operation.	-----	Section 70, Group 5.
Check operation of rear axle disconnect	-----	Section 50, Group 11

**BEFORE DELIVERING LOADER - Continued**

Service	Specifications	Reference
Check clutch cutoff control disconnect.	-----	Section 60, Group 5.
Check brake operation.	-----	Section 60, Group 5.
Check steering operation.	-----	Section 60, Group 5.
<b>TIRES AND WHEELS</b>		
Check air pressure.	-----	Operator's Manual.
Check all wheel retainers for tightness.	275 ft-lbs torque.	Operator's Manual.
<b>GENERAL</b>		
Tighten accessible nuts and cap screws.	-----	-----
Clean loader and touch up paint.	-----	-----

**DELIVERY SERVICE**

A thorough discussion of the operation and service of a new loader at the time of delivery helps to assure complete customer satisfaction. Proper delivery is an important phase of a dealer's program. One section of the John Deere Delivery Receipt emphasizes the importance of proper delivery service.

Complaints may arise if the owner is not shown how to operate and service his new loader correctly. Devote enough time, at your customer's convenience, to introduce him to his new loader.

The following procedure is recommended before the service man and owner complete the delivery acknowledgements section of the delivery receipt.

Using the operator's manual as a guide, be sure the owner thoroughly understands the following points:

1. Operation and use of controls and instruments.
2. Operation of the engine.
3. Importance of the break-in period.
4. Operation and functions of the hydraulic system.
5. Operation and use of the power shift transmission.
6. Importance of lubrication and periodic services.
7. Importance of safety.
8. Terms and conditions of warranty.

After explaining and demonstrating the above points, have the owner sign the delivery receipt and give him his operator's manual.

**AFTER-SALES SERVICE**

The purchaser of a new John Deere loader is entitled to a free inspection at some mutually agreeable time within the warranty period after the equipment has been "run in". The terms of this after-sales inspection are outlined on the back of the customer's John Deere Delivery Receipt.

If the recommended after-sales service inspection is followed, the dealer can eliminate minor irregularities which could develop into major service problems at a later date. This will promote strong dealer-customer relations and present an opportunity to answer questions that may have arisen during initial operation.

The purpose of this inspection is to ensure that the customer is receiving satisfactory performance from his loader. At the same time, the inspection should reveal whether or not the machine is being operated, lubricated, and serviced properly.

During the inspection service, the dealer has the further opportunity of promoting the sale of additional new equipment and accessories.

**INSPECTION PROCEDURE**

Service	Specifications	Reference
<b>COOLING SYSTEM</b>		
Check radiator coolant level.	Midway between radiator core and filler neck.	-----
Check hoses for loose connections and leaks.	-----	-----
<b>ELECTRICAL SYSTEM</b>		
Check specific gravity of batteries.	Full charge - 1.260 at 80°F.	Operator's Manual.
Check level of battery electrolyte.	To bottom of filler neck in each cell.	Operator's Manual.
Check alternator belt tension.	3/4-inch deflection with a 20-pound force.	Operator's Manual.
Start engine and check action of starter, lights, and indicator lamps.	-----	Operator's Manual.
<b>LUBRICATION</b>		
Check engine crankcase oil level.	Between marks on dipstick.	Operator's Manual.
Check loader hydraulic system oil level.	Check oil level at window (JD303 Special-Purpose Oil).	Operator's Manual.
Check front and rear differential oil levels.	To level of check plug (cold oil) (JD303 Special-Purpose Oil).	Operator's Manual.
Check transmission oil level.	To top mark on dipstick. (J.D. Torque Converter Fluid Type C-2).	Operator's Manual.

**INSPECTION PROCEDURES - Continued**

Service	Specifications	Reference
<b>ENGINE</b>		
Check engine valve tappet clearance.	Intake - 0.014-inch Exhaust - 0.018-inch	Section 20, Group 10.
<b>FUEL SYSTEM</b>		
Bleed fuel system.	-----	Operator's Manual.
Check fuel line connections.	-----	-----
Check air cleaner element and unloading valve. Clean element if necessary.	-----	Operator's Manual.
<b>HYDRAULIC SYSTEM</b>		
Check power steering.	-----	Section 60, Group 5.
Check power brakes.	With engine stopped, pedal travel should not exceed two inches with firm but moderate effort.	-----
Check brake accumulator.	20 brake pedal applications with engine stopped.	-----
Tighten accessible oil lines and hoses.	-----	-----
<b>CONTROLS</b>		
Check clutch cutoff disconnect.	-----	Section 60, Group 25.
Check return-to-dig valve operation.	Check oil level and adjust (JD303 Special-Purpose Oil).	Operator's Manual.

INSPECTION PROCEDURES—Continued

Service	Specifications	Reference
<b>GENERAL</b>		
Tighten the transmission front output shaft retaining nut.	600-700 lb-ft	Operator's Manual
Tighten accessible nuts and bolts.	-----	Section 10, Group 25.
Check air cleaner hoses for breaks or loose connections.	-----	-----
Visual Inspection.	-----	-----

## Group 15 TUNE-UP AND ADJUSTMENT

### GENERAL INFORMATION

Before tuning up an engine, determine if it is in condition so that performance can be restored by tune-up. Perform the following tests:

#### PRELIMINARY ENGINE TESTING

Operation	Specification	Reference
Vacuum test (at air cleaner)	8-25 inches of water at fast idle	.....
Intake manifold pressure (diesel engine with altitude compensating turbocharger)	6 to 8 psi at 2500 rpm, full load	Section 30, Group 15
Check radiator for air bubbles and indication of oil	.....	Section 20, Group 25
Cylinder compression	300 psi*	Section 20, Group 10
Engine power output (at flywheel) (use dynamometer)	Note hp. output and compare with output after tune-up	.....

#### ENGINE TUNE-UP

##### AIR INTAKE SYSTEM

Air cleaner - clean primary element and dust cup	.....	Section 30, Group 15
Check breather pipe for restrictions	.....	.....
Retighten cylinder head cap screws	110 ft-lbs	Section 20, Group 10
Check valve clearance	0.018 in. -Exhaust 0.014 in. -Intake	Section 20, Group 10

##### BATTERY

Check electrolyte level	.....	.....
Clean cables, terminals and box	.....	.....
Tighten cable clamps	.....	.....

\*The most important factor in compression readings is the difference between cylinders. This difference should be no more than 50 psi.

ENGINE TUNE-UP—Continued

Operation	Specification	Reference
<b>ALTERNATOR</b>		
Check belt tension	20 lb. at 3/4 in. deflection.	.....
<b>FUEL SYSTEM</b>		
Check fuel tank and lines for leaks or restrictions	.....	.....
Clean fuel transfer pump bowl and strainer	.....	.....
Replace fuel filter elements	.....	.....
Time injection pump	.....	Section 30, Group 25
Check injection pump advance	.....	Section 30, Group 25
Bleed fuel system	.....	.....
Adjust speed control linkage and check engine speeds	.....	Section 20, Group 20
<b>ENGINE LUBRICATION SYSTEM</b>		
Check engine oil pressure	45-65 psi at 2500 rpm. (180° to 220° F.)	Section 20, Group 15
<b>COOLING SYSTEM</b>		
Clean and flush system	.....	.....
Inspect hoses	.....	.....
Clean trash from radiator	.....	.....
<b>EXHAUST SYSTEM</b>		
Check system for leaks	.....	FOS 30 - ENGINES
Check muffler and exhaust pipe for restrictions.	.....	FOS 30 - ENGINES

### FINAL ENGINE TESTING

Use a dynamometer in final testing to determine if engine is performing at rated horsepower. Compare output of engine with horsepower delivered prior to tune-up.

### LOADER ADJUSTMENTS

Make the following loader adjustments whenever the engine is tuned up.

Operation	Specification	Reference
<b>BRAKES</b>		
Bleed brakes	.....	Section 60, Group 25
Check action of brake accumulator	.....	Section 60, Group 5
Check mechanical parking brake	.....	Section 60, Group 25
<b>POWER STEERING</b>		
Bleed steering system	.....	Section 60, Group 20
Check time cycle (limit to limit) at 1000 rpm engine speed	4.0 seconds	Section 60, Group 5
Check steering system accumulator	.....	Section 60, Group 15
<b>HYDRAULIC SYSTEM</b>		
Check boom raise cycle time	5.7 to 6.2 seconds	Section 70, Group 5
Check boom lower cycle time (power down)	4.5 to 5.0 seconds	Section 70, Group 5
Check bucket dump cycle time	1.6 to 2.0 seconds	Section 70, Group 5
Bleed bucket return-to-dig valve	.....	Section 70, Group 25
<b>TIRES</b>		
Check tire inflation	.....	See Operator's Manual
<b>TIGHTEN ACCESSIBLE HARDWARE</b>	See torque chart.	Section 10, Group 25

## Group 20 LUBRICATION

### GENERAL INFORMATION

Carefully written and illustrated lubrication instructions are included in the operator's manual furnished with your customer's machine. A periodic service chart is also mounted on the loader battery box for operator convenience on later model loaders.

For your convenience, the following chart shows capacities and type of lubricants for the loader components and systems. Specifications for lubricants follow the chart.

Remind him to follow these instructions.

	Capacity	Type of Lubricant
Engine crankcase	12 U.S. quarts (including filter)	See page 20-2.
Transmission, steering and brakes system	10 U.S. gallons (after initial fill 9-3/4 gallons)	J.D. Torque Converter Fluid Type C-2
Loader hydraulic system sump	12 U.S. gallons	J.D. Type 303 Special-Purpose Oil or an equivalent.
Return-to-dig valve	To level of filler plug	J.D. Type 303 Special-Purpose Oil or an equivalent.
Differentials	4-3/4 U.S. gallons (4-1/4 for "No Spin" option)	J.D. Type 303 Special-Purpose Oil or an equivalent.
Grease fittings	.....	John Deere Multi-Purpose Lubricant or an equivalent.
Axle bearings	10 to 20 shots	John Deere Multi-Purpose Lubricant or an equivalent.
Starter	Saturate wicks (3)	Engine crankcase oil (SAE10W)
	Lubricate armature shaft splines during assembly	Engine crankcase oil (SAE10W)
Loader Hydraulic system (sump, lines and cylinders)	21 U.S. gallons	J.D. Type 303 Special-Purpose Oil or an equivalent.

## LUBRICANTS

Effective use of lubricating oils and greases is perhaps the most important step towards low upkeep cost, long loader life, and satisfactory service. Use only lubricants specified in this section; apply them at intervals and according to the instructions in the lubrications and periodic service section.

### ENGINE LUBRICATING OILS



We recommend John Deere Torq-Gard or Torq-Gard Supreme engine oil for use in the engine crankcase. This oil is compounded specifically for use in John Deere engines, and provides superior lubrication under all conditions. **NEVER PUT ADDITIVES IN THE CRANKCASE.** Torq-Gard oil is formulated to provide all the protection your engine needs. Additives could reduce this protection rather than help it.

If oil other than Torq-Gard or Torq-Gard Supreme is used, it must conform to the following specifications.

#### SINGLE VISCOSITY OILS

API Service CD/SD  
MIL-L-2104C  
Series 3

#### MULTI-VISCOSITY OILS

API Service CC/SD  
MIL-L-46152

Depending on the expected prevailing temperature for the fill period, use oil of viscosity as shown in the following chart.

Air Temperature	John Deere Torq-Gard Oil	Other Oils	
		Single Viscosity	Multi-Viscosity
Above 32° F.	SAE 30	SAE 30	Not recommended.
-10° F. to 32° F.*	SAE 10W-20	SAE 10W	SAE 10W-30
Below -10° F.	SAE 5W-20	SAE 5W	SAE 5W-20

*\*SAE 5W-20 oil may also be used to insure optimum lubrication at starting, particularly when engine is subjected to -10° F. or lower temperatures for several hours.*

*Some increase in oil consumption may be expected when SAE 5W-20 or SAE 5W oils are used. Check oil level more frequently.*

### TRANSMISSION, STEERING, AND BRAKE SYSTEM

Use John Deere Torque Converter Fluid (Type C-2) or an equivalent in the transmission, steering, and brake system.

### LOADER HYDRAULIC SYSTEM

Use John Deere Type 303 Special-Purpose Oil or an equivalent in the loader hydraulic system.

**IMPORTANT: Do not use John Deere Type 303 Special-Purpose Oil in the transmission.**

### GREASES

Use John Deere Multi-Purpose Lubricant or an equivalent for all grease fittings. Application of grease as instructed in the lubrication section will provide proper lubrication and will keep contamination out of bearings.

### STORING LUBRICANTS

Your loader can operate at top efficiency only if clean lubricants are used. Use clean containers to handle all lubricants. Store them in an area protected from dust, moisture, and other contamination.

## Group 25 LOADER SEPARATION

### SEPARATING LOADER AND ENGINE FRAMES

Disconnect battery ground strap. Operate controls to release hydraulic pressure from loader hydraulic system and steering and brake hydraulic system.

Remove plate on top of loader oil reservoir and disconnect bucket return-to-dig oil tube from loader control valve.

Support front and rear sections of loader and engine frames with heavy-duty stands to prevent frames from pivoting. Frames should be supported as evenly as possible to facilitate installation.

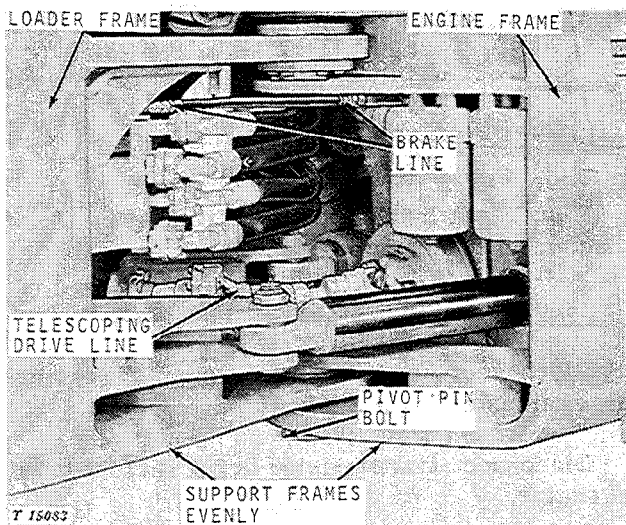

Fig. 1—Separating Frames—Lower Pivot Points

Refer to Figures 1 and 2 and perform the following steps:

1. Disconnect loader hoses, telescoping drive shaft, front lights, and front brake oil line.

2. Remove steering cylinder pivot pins. Keep washers and beveled spacers together for installation.

Do not damage threads on top of pivot pins while driving them out.

3. Remove cap screw and grease fitting from lower pivot pin and remove pin.

4. Remove the operator's platform.

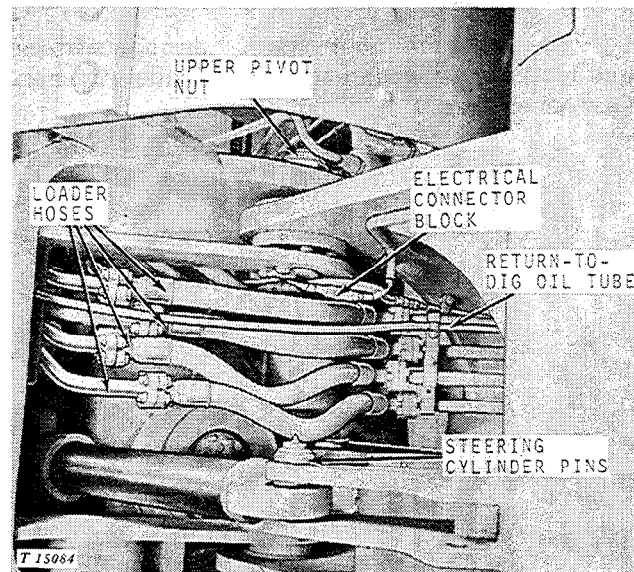

Fig. 2—Separating Frames—Upper Pivot Points

5. Remove upper pivot pin.

6. Attach a hoist to the loader frame and roll it away from the engine frame.

### JOINING LOADER AND ENGINE FRAMES



**CAUTION:** Keep support stands under front and rear of loader and engine frames until installation is completed.

With frame pivot points aligned, install pivot pins. Secure upper pivot pin with plate and large nut and tighten to specified torque. See Section 80, Group 5 for checking upper hinge ball-rolling torque.

Install cap screw through bottom of lower pivot pin and secure with self-locking nut. Install grease fitting.

Secure steering cylinders to loader frame with pins and washers. Position spacers on top of self-aligning bushing with beveled side of spacer against bushing. Insert pivot pin (threaded end up) and secure with washer and nut. Tighten nut to specifications. Install operator's platform.

Connect telescoping drive shaft. Connect loader hoses and bucket return-to-dig oil tube.

Connect front lights and brake oil line.

### REMOVING ENGINE

Operate controls to release hydraulic pressure from loader hydraulic system and steering and brakes hydraulic system.

Pull pins from pivot lock bar on engine frame and lock bar between engine and loader frames. Disconnect battery ground strap.

Disconnect transmission oil lines from engine-mounted hydraulic pump. Remove clamps from lines to aid in engine removal (Fig. 4).

Disconnect speed control rod from fuel injection pump.

Disconnect fuel leak-off line.

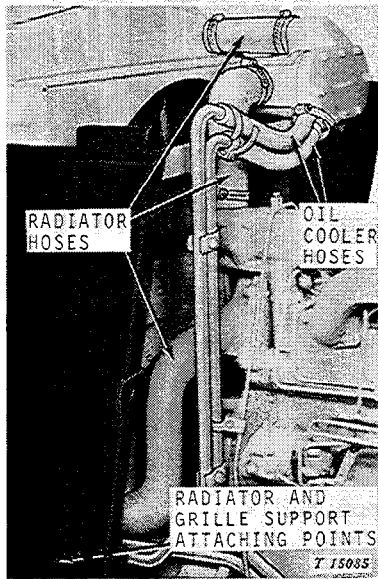

Fig. 3-Grille and Radiator Attaching Points

Remove hood and drain radiator. Disconnect inlet and outlet hoses. Disconnect oil cooler hoses and remove cooler, radiator, and grille.

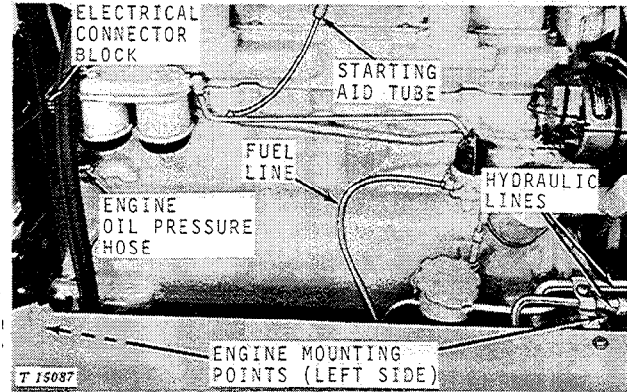

Fig. 5-Disconnecting Left Side of Engine

Disconnect hydraulic lines from pump. Also disconnect rear pump leak-off line.

Disconnect fuel line at transfer pump.

Disconnect electrical harness, oil pressure hose, and starting aid tube.

Disconnect transmission drive shaft at front of engine.

With a hoist supporting engine, remove cap screws securing left engine brackets to engine frame.

Remove right engine brackets for extra clearance during engine removal.

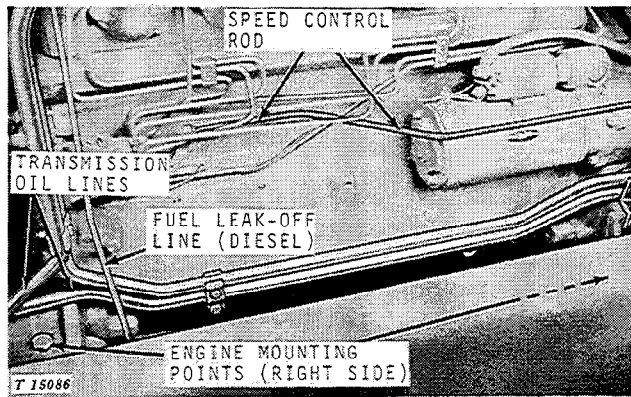

Fig. 4-Disconnecting Right Side of Engine

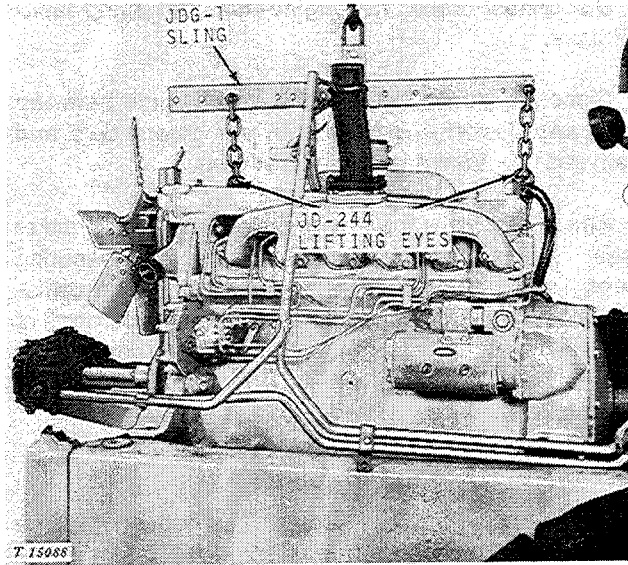

Fig. 6-Removing Engine

Attach JDG-1 or JDG-23 Engine Lifting Sling or D01043AA Load Positioning Sling to engine using two JD244 Lifting Eyes or JDG-19 Lifting Brackets.

Using a hoist, pull engine forward and lift from frame (Fig. 6).

## INSTALLATION

Check condition of bonded rubber engine-mounting pads (13, Fig. 7) in engine frame. If replacement is necessary, soap outside of mounts and press into engine frame.

Position engine in engine frame and tighten hardware to specified torque.

Connect transmission drive shaft to front of engine.

Connect electrical wiring harness.

Connect fuel line to fuel transfer pump and fuel leak-off line to injection pump.

Connect hydraulic lines to pump and install rear pump leak-off line.

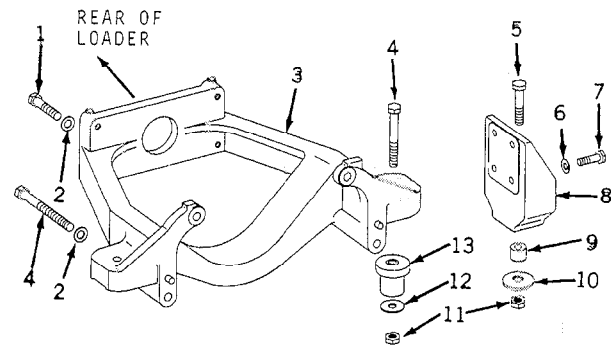

T 15089

- |                        |                          |
|------------------------|--------------------------|
| 1—Cap Screw (2 used)   | 8—Bracket (2 used)       |
| 2—Washer (4 used)      | 9—Spacer (2 used)        |
| 3—Support              | 10—Washer (2 used)       |
| 4—Cap Screw (4 used)   | 11—Nut (4 used)          |
| 5—Cap Screw (2 used)   | 12—Washer (2 used)       |
| 6—Lock Washer (8 used) | 13—Mounting Pad (2 used) |
| 7—Cap Screw (8 used)   |                          |

Fig. 7-Exploded View of Engine Supports

Install grille support, radiator, and oil cooler, making sure all baffling is in place.

Connect radiator and oil cooler hoses.

Connect speed control rod to fuel injection pump.

Connect air cleaner hose to air intake manifold.

Install muffler, hood, precleaner (or air cleaner stack), and grille screen.

Fill radiator.

Connect battery ground strap.

Start engine and check fuel line, all hydraulic lines, and radiator hoses for leaks.



**Suggest:**

**If the above button click is invalid.**

**Please download this document**

**first, and then click the above link**

**to download the complete manual.**

**Thank you so much for reading**

## REMOVING TRANSMISSION

Pull pins from pivot lock bar on engine frame and secure bar between engine and loader frames. Disconnect battery ground strap.

Remove battery compartment, seat, and operator's platform. Battery compartment need not be removed if hoist equipment is high enough to raise transmission over compartment. Disconnect and remove front speed control rod. Remove platform rear support bar for clearance.

Operate controls to release hydraulic pressure from loader hydraulic system and steering and brakes hydraulic system and drain transmission and loader oil reservoirs.

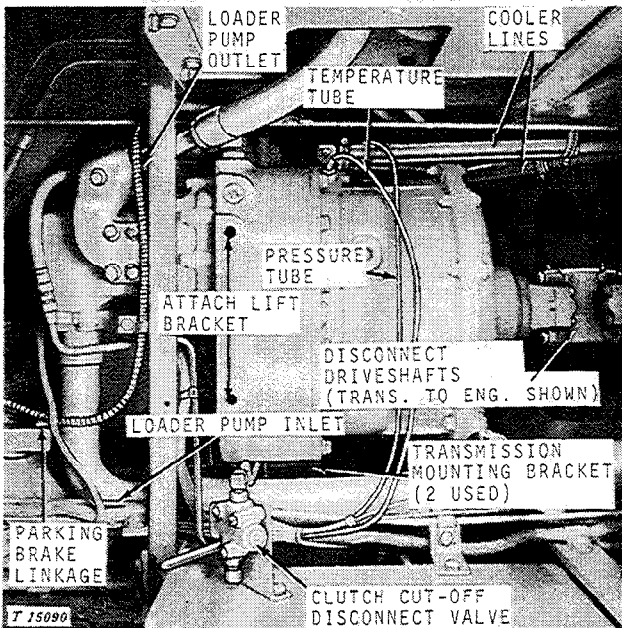

Fig. 8-Disconnecting Transmission

Disconnect transmission oil filter and oil cooler lines, and loader pump inlet and outlet lines (Fig. 8).

Disconnect transmission oil pressure and temperature sending tubes. Remove transmission shift cable. Disconnect starter safety switch.

Remove clutch cut-off disconnect valve.

Disconnect parking brake linkage.

Disconnect brake and engine-mounted pump leak-off lines.

Disconnect drive shafts at universal joints between the transmission and front and rear differentials and between the transmission and engine.

Attach a hoist to the transmission, using lift bracket (see "Special Tools"). Remove cap screws securing transmission brackets to engine frame. With transmission completely disconnected, lift transmission out of engine frame. When transmission is halfway out of engine frame, remove left support bracket for extra removal clearance.

## INSTALLATION

Using a hoist, position transmission between engine frame side rails, tighten transmission mounting brackets-to-engine frame cap screws to specified torque.

Connect all drive shafts at universal joints.

Connect brake and pump leak-off lines.

Connect parking brake linkage and transmission shift cable.

Install clutch cut-off disconnect valve.

Connect transmission oil filter lines. Connect transmission oil pressure and temperature sending tubes. Connect starter safety switch.

Connect transmission oil cooler lines, loader pump inlet and outlet lines.

Install rear platform support, front speed control rod, operator's platform and seat. Install battery compartment if removed. Connect battery ground strap.

Fill transmission and loader reservoirs with recommended oils (see Group 20).

**<https://www.ebooklibonline.com>**

Hello dear friend!

Thank you very much for reading.

Enter the link into your browser.

The full manual is available for immediate download.

**<https://www.ebooklibonline.com>**