

This technical manual is written for an experienced technician and contains sections that are specifically for this product. It is a part of a total product support program.

The manual is organized so that all the information on a particular system is kept together. The order of grouping is as follows:

- Table of Contents
- General Diagnostic Information
- Specifications
- Electrical Wiring Harness Legend
- Component Location
- System Schematic
- Wiring Harness
- Troubleshooting Chart
- Theory of Operation
- Diagnostics
- Tests and Adjustments
- Repair

Note: Depending on the particular section or system being covered, not all of the above groups may be used.

Each section will be identified with a symbol rather than a number. The groups and pages within a section will be consecutively numbered.

We appreciate your input on this manual. To help, there are postage paid post cards included at the back. If you find any errors or want to comment on the layout of the manual please fill out one of the cards and mail it back to us.

All information, illustrations and specifications in this manual are based on the latest information available at the time of publication. The right is reserved to make changes at any time without notice.

COPYRIGHT© 1999
Deere & Co.
John Deere Worldwide Commercial and
Consumer Equipment Division
Horicon, WI
All rights reserved
Previous Editions
COPYRIGHT© 1996, 1995, 1994, 1992,
1991, 1990, 1989, and 1988

Safety



Specifications and Information



Engine



Diesel Engine



Electrical



Hydrostatic Power Train



Steering



Brakes



Hydraulics



Miscellaneous





RECOGNIZE SAFETY INFORMATION



This is the safety-alert symbol. When you see this symbol on your machine or in this manual, be alert to the potential for personal injury.

Follow recommended precautions and safe servicing practices.

Understand Signal Words

A signal word—DANGER, WARNING, or CAUTION—is used with the safety-alert symbol. DANGER identifies the most serious hazards.

DANGER or WARNING safety signs are located near specific hazards. General precautions are listed on CAUTION safety signs. CAUTION also calls attention to safety messages in this manual.

REPLACE SAFETY SIGNS

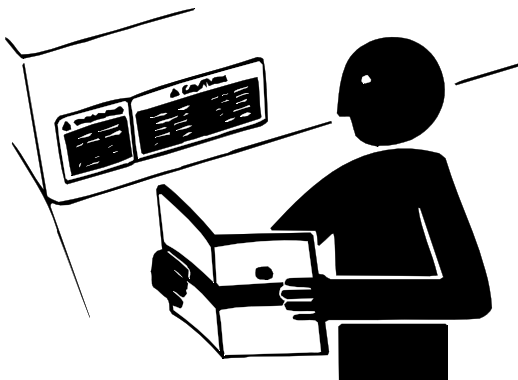

Replace missing or damaged safety signs. See the machine operator's manual for correct safety sign placement.

HANDLE FLUIDS SAFELY—AVOID FIRES

Be Prepared for Emergencies

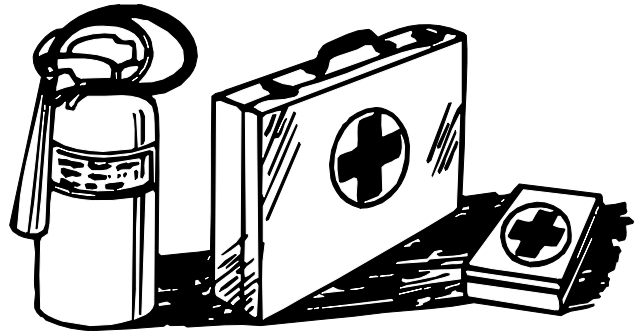

When you work around fuel, do not smoke or work near heaters or other fire hazards.

Store flammable fluids away from fire hazards. Do not incinerate or puncture pressurized containers.

Make sure machine is clean of trash, grease, and debris.

Do not store oily rags; they can ignite and burn spontaneously.

Be prepared if a fire starts.

Keep a first aid kit and fire extinguisher handy.

Keep emergency numbers for doctors, ambulance service, hospital, and fire department near your telephone.

<https://www.ebooklibonline.com>

Hello dear friend!

Thank you very much for reading.

Enter the link into your browser.

The full manual is available for immediate download.

<https://www.ebooklibonline.com>

USE CARE IN HANDLING AND SERVICING BATTERIES

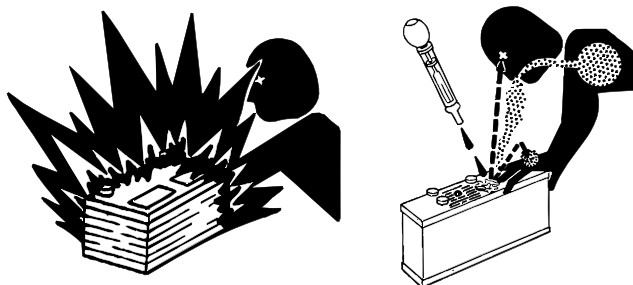

Prevent Battery Explosions

- Keep sparks, lighted matches, and open flame away from the top of battery. Battery gas can explode.
- Never check battery charge by placing a metal object across the posts. Use a voltmeter or hydrometer.
- Do not charge a frozen battery; it may explode. Warm battery to 16°C (60°F).

Prevent Acid Burns

- Sulfuric acid in battery electrolyte is poisonous. It is strong enough to burn skin, eat holes in clothing, and cause blindness if splashed into eyes.
- **Avoid acid burns by:**
 1. Filling batteries in a well-ventilated area.
 2. Wearing eye protection and rubber gloves.
 3. Avoiding breathing fumes when electrolyte is added.
 4. Avoiding spilling or dripping electrolyte.
 5. Using proper jump start procedure.
- **If you spill acid on yourself:**
 1. Flush your skin with water.
 2. Apply baking soda or lime to help neutralize the acid.
 3. Flush your eyes with water for 10—15 minutes.
 4. Get medical attention immediately.
- **If acid is swallowed:**
 1. Drink large amounts of water or milk.
 2. Then drink milk of magnesia, beaten eggs, or vegetable oil.
 3. Get medical attention immediately.

USE CARE AROUND HIGH-PRESSURE FLUID LINES

Avoid High-Pressure Fluids

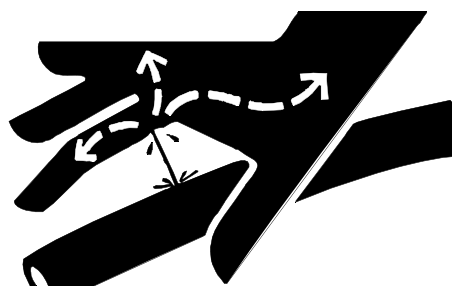

Escaping fluid under pressure can penetrate the skin causing serious injury.

Avoid injury from escaping fluid under pressure by stopping the engine and relieving pressure in the system before disconnecting or connecting hydraulic or other lines. Tighten all connections before applying pressure.

Search for leaks with a piece of cardboard. Protect hands and body from high-pressure fluids.

If an accident occurs, see a doctor immediately. Any fluid injected into the skin must be surgically removed within a few hours or gangrene may result. Doctors unfamiliar with this type of injury should reference a knowledgeable medical source. Such information is available from Deere & Company Medical Department in Moline, Illinois, U.S.A.

Avoid Heating Near Pressurized Fluid Lines



Flammable spray can be generated by heating near pressurized fluid lines, resulting in severe burns to yourself and bystanders. Do not heat by welding, soldering, or using a torch near pressurized fluid lines or other flammable materials. Pressurized lines can be accidentally cut when heat goes beyond the immediate flame area.



USE SAFE SERVICE PROCEDURES

Wear Protective Clothing

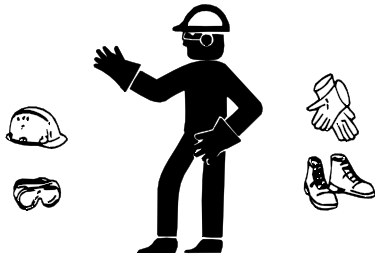

Wear close fitting clothing and safety equipment appropriate to the job.

Prolonged exposure to loud noise can cause impairment or loss of hearing. Wear a suitable hearing protective device such as earmuffs or earplugs to protect against objectionable or uncomfortable loud noises.

Operating equipment safely requires the full attention of the operator. Do not wear radio or music headphones while operating machine.

Service Machines Safely

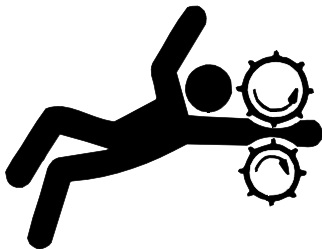

Tie long hair behind your head. Do not wear a necktie, scarf, loose clothing, or necklace when you work near machine tools or moving parts. If these items were to get caught, severe injury could result.

Remove rings and other jewelry to prevent electrical shorts and entanglement in moving parts.

Use Proper Tools

Use tools appropriate to the work. Makeshift tools and procedures can create safety hazards. Use power tools only to loosen threaded parts and fasteners. For loosening and tightening hardware, use the correct size tools. **DO NOT** use U.S. measurement tools on metric fasteners. Avoid bodily injury caused by slipping wrenches. Use only service parts meeting John Deere specifications.

Park Machine Safely

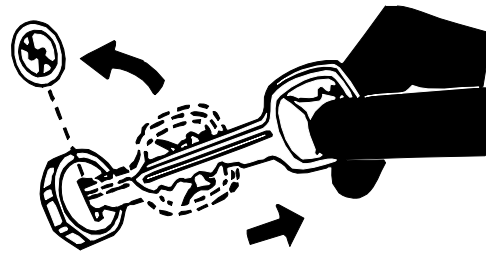

Before working on the machine:

1. Lower all equipment to the ground.
2. Stop the engine and remove the key.
3. Disconnect the battery ground strap.
4. Hang a "DO NOT OPERATE" tag in operator station.

Support Machine Properly and Use Proper Lifting Equipment

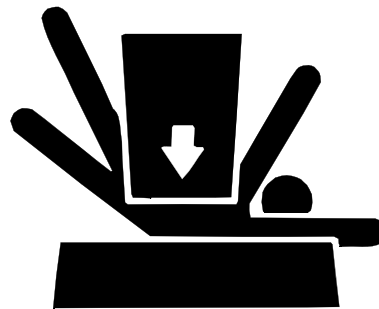

If you must work on a lifted machine or attachment, securely support the machine or attachment.

Do not support the machine on cinder blocks, hollow tiles, or props that may crumble under continuous load. Do not work under a machine that is supported solely by a jack. Follow recommended procedures in this manual.

Lifting heavy components incorrectly can cause severe injury or machine damage. Follow recommended procedure for removal and installation of components in the manual.

Work in Clean Area

Before starting a job:

1. Clean work area and machine.
2. Make sure you have all necessary tools to do your job.
3. Have the right parts on hand.
4. Read all instructions thoroughly; do not attempt shortcuts.

Using High—Pressure Washers

Directing pressurized water at electronic/electrical components or connectors, bearings, hydraulic seals, fuel injection pumps or other sensitive parts and components may cause product malfunctions. Reduce pressure and spray at a 45 to 90 degree angle.

Illuminate Work Area Safely

Illuminate your work area adequately but safely. Use a portable safety light for working inside or under the machine. Make sure the bulb is enclosed by a wire cage. The hot filament of an accidentally broken bulb can ignite spilled fuel or oil.

Work in Ventilated Area

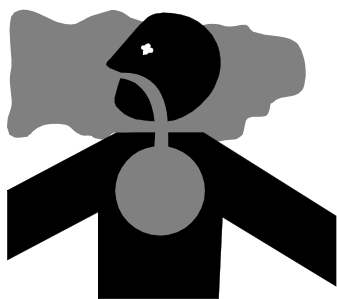

Engine exhaust fumes can cause sickness or death. If it is necessary to run an engine in an enclosed area, remove the exhaust fumes from the area with an exhaust pipe extension.

If you do not have an exhaust pipe extension, open the doors and get outside air into the area.

WARNING: California Proposition 65 Warning

Diesel engine exhaust and some of its constituents are known to the State of California to cause cancer, birth defects, and other reproductive harm.

Gasoline engine exhaust from this product contains chemicals known to the State of California to cause cancer, birth defects, or other reproductive harm.

Remove Paint Before Welding or Heating

Avoid potentially toxic fumes and dust. Hazardous fumes can be generated when paint is heated by welding, soldering, or using a torch. Do all work outside or in a well ventilated area. Dispose of paint and solvent properly. Remove paint before welding or heating. If you sand or grind paint, avoid breathing the dust. Wear an approved respirator. If you use solvent or paint stripper, remove stripper with soap and water before welding. Remove solvent or paint stripper containers and other flammable material from area. Allow fumes to disperse at least 15 minutes before welding or heating.

Avoid Harmful Asbestos Dust

Avoid breathing dust that may be generated when handling components containing asbestos fibers. Inhaled asbestos fibers may cause lung cancer.

Components in products that may contain asbestos fibers are brake pads, brake band and lining assemblies, clutch plates, and some gaskets. The asbestos used in these components is usually found in a resin or sealed in some way. Normal handling is not hazardous as long as airborne dust containing asbestos is not generated.

Avoid creating dust. Never use compressed air for cleaning. Avoid brushing or grinding material containing asbestos. When servicing, wear an approved respirator. A special vacuum cleaner is recommended to clean asbestos. If not available, apply a mist of oil or water on the material containing asbestos. Keep bystanders away from the area.



SERVICE TIRES SAFELY



Explosive separation of a tire and rim parts can cause serious injury or death.

Do not attempt to mount a tire unless you have the proper equipment and experience to perform the job. Always maintain the correct tire pressure. Do not inflate the tires above the recommended pressure. Never weld or heat a wheel and tire assembly. The heat can cause an increase in air pressure resulting in a tire explosion. Welding can structurally weaken or deform the wheel.

When inflating tires, use a clip-on chuck and extension hose long enough to allow you to stand to one side and NOT in front of or over the tire assembly. Use a safety cage if available.

Check wheels for low pressure, cuts, bubbles, damaged rims or missing lug bolts and nuts.



**AVOID INJURY FROM ROTATING
BLADES, AUGERS AND PTO
SHAFTS**

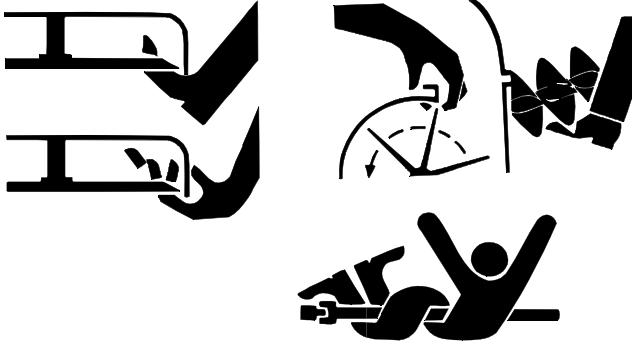

Keep hands and feet away while machine is running. Shut off power to service, lubricate, or remove mower blades, augers, or PTO shafts.

**SERVICE COOLING SYSTEM
SAFELY**



Explosive release of fluids from pressurized cooling system can cause serious burns.

Shut off machine. Remove filler cap only when cool enough to touch with bare hands. Slowly loosen cap to first stop to relieve pressure before removing completely.

**HANDLE CHEMICAL PRODUCTS
SAFELY**

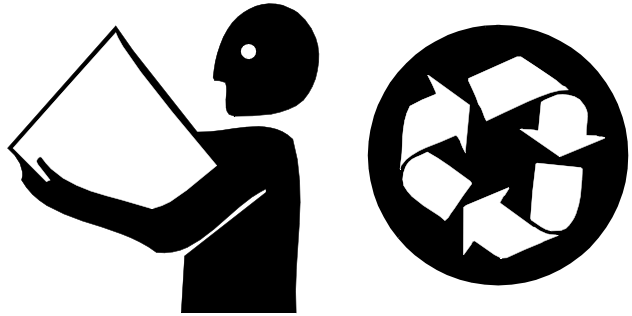

Direct exposure to hazardous chemicals can cause serious injury. Potentially hazardous chemicals used with John Deere equipment include such items as lubricants, coolants, paints, and adhesives.

A Material Safety Data Sheet (MSDS) provides specific details on chemical products: physical and health hazards, safety procedures, and emergency response techniques. Check the MSDS before you start any job using a hazardous chemical. That way you will know exactly what the risks are and how to do the job safely. Then follow procedures and recommended equipment.

Dispose of Waste Properly

Improperly disposing of waste can threaten the environment and ecology. Potentially harmful waste used with John Deere equipment includes such items as oil, fuel, coolant, brake fluid, filters, and batteries. Use leakproof containers when draining fluids. Do not use food or beverage containers that may mislead someone into drinking from them. Do not pour waste onto the ground, down a drain, or into any water source. Inquire on the proper way to recycle or dispose of waste from your local environmental or recycling center, or from your John Deere dealer.

LIVE WITH SAFETY



Before returning machine to customer, make sure machine is functioning properly, especially the safety systems. Install all guards and shields.

CONTENTS

SPECIFICATIONS AND INFORMATION

	Page
GENERAL VEHICLE SPECIFICATIONS	10
TORQUE VALUES, NON-STANDARD FASTENERS	10
GASOLINE ENGINE	10
DIESEL ENGINE	11
POWER TRAIN, HYDROSTATIC	12
STEERING	12
BRAKES	12
HYDRAULICS	12
METRIC FASTENER TORQUE VALUES	13
INCH FASTENER TORQUE VALUES	14
O-RING SEAL SERVICE RECOMMENDATIONS	15
FACE SEAL FITTINGS WITH INCH STUD ENDS TORQUE	15
FACE SEAL FITTINGS WITH METRIC STUD ENDS TORQUE	16
O-RING FACE SEAL FITTINGS	17
O-RING BOSS FITTINGS	17
STRAIGHT FITTING OR SPECIAL NUT TORQUES	18
METRIC FASTENER TORQUE VALUE—GRADE 7 (SPECIAL)	18
GASOLINE	19
4-CYCLE ENGINES	19
GASOLINE STORAGE	19
DIESEL FUEL	20
DIESEL FUEL LUBRICITY	20
DIESEL FUEL STORAGE	20
ENGINE OIL SPECIFICATIONS	21
4-CYCLE DIESEL ENGINE OIL	21
4-CYCLE GASOLINE ENGINE OIL	22
BREAK-IN ENGINE OIL—DIESEL	23
BREAK-IN ENGINE OIL—4-CYCLE GASOLINE	24
HYDROSTATIC TRANSMISSION AND HYDRAULIC OIL	25
HYDROSTATIC TRANSMISSION AND HYDRAULIC OIL	25
GEAR CASE OIL SPECIFICATIONS	26
GEAR CASE OIL	26
GEAR TRANSMISSION GREASE SPECIFICATIONS	27
GEAR TRANSMISSION GREASE	27
ALTERNATIVE LUBRICANTS	28
SYNTHETIC LUBRICANTS	28
LUBRICANT STORAGE	28
MIXING OF LUBRICANTS	28
OIL FILTERS	28
COOLANT SPECIFICATIONS	29
DIESEL AND GASOLINE ENGINE COOLANT	29
DIESEL AND GASOLINE ENGINE COOLANT DRAIN INTERVAL	29
SERIAL NUMBER LOCATIONS	30





	Page
PRODUCT SERIAL NUMBER	30
DIESEL ENGINE SERIAL NUMBER LOCATION	30
GASOLINE ENGINE SERIAL NUMBER LOCATION	30
TRANSAXLE SERIAL NUMBER LOCATION	30

GENERAL VEHICLE SPECIFICATIONS

TORQUE VALUES, NON-STANDARD FASTENERS

All torque specifications are subject to final verification.

NOTE: Torques listed in this GROUP apply ONLY to "special" and/or NON-STANDARD fasteners. Unless otherwise specified, STANDARD fasteners should be torqued per "TORQUE VALUES, STANDARD METRIC METRIC FASTENER" or "TORQUE VALUES, STANDARD INCH FASTENER".

GASOLINE ENGINE

Engine Mounting Cap Screws	80 N•m (60 lb-ft)
Valve Clearance Adjusting Nut	9 N•m (79 lb-in.)
Carburetor Mounting Nuts	17 N•m (12 lb-ft)
Intake Manifold Cap Screw (Final)	6 N•m (53 lb-in.)
Pressure Relief Plug	15 N•m (133 lb-in.)
Thermostat Housing Cap Screws	6 N•m (53 lb-in.)
Rocker Arm Adjuster Screw Lock Nut	9 N•m (79 lb-in.)
Cylinder Head Cap Screw (Final)	21 N•m (186 lb-in.)
Spark Plug	20 N•m (177 lb-in.)
Crankcase Cover Cap Screw	21 N•m (186 lb-in.)
Crankcase Drain Plug	23 N•m (204 lb-in.)
Connecting Rod Cap Screw	21 N•m (186 lb-in.)
Coolant Pump Cap Screw	8 N•m (70 lb-in.)
Crankcase Cover Cap Screw	23 N•m (17 lb-ft)
Oil Pump Cover Cap Screw	7.8 N•m (69 lb-in.)
Ignition Coil Cap Screws	9.8 N•m (87 lb-in.)
Starting Motor Mounting Cap Screw	15.3 N•m (135 lb-in.)
Governor Arm Nut	7.8 N•m (69 lb-in.)

Flywheel:

Flywheel Nut	108 N•m (80 lb-ft)
Flywheel Sheave	15 N•m (130 lb-ft)
Fan Belt Drive Sheave Screw	15 N•m (133 lb-in.)

Carburetor—425:

Throttle Shaft Retaining Screw	2 N•m (17 lb-in.)
Drain Screw	1.2 N•m (10 lb-in.)
Choke and Throttle Valve Screw	0.88 N•m (7.8 lb-in.)
Solenoid Valve Torque	9.8 N•m (87 lb-in.)
Main Jet and Main Air Jet Torque	1.0 N•m (8.9 lb-in.)
Air Horn Mounting Screws	2.9 N•m (26 lb-ft)

Throttle Body—445:

Throttle Shaft Retaining Screw	2.0 N•m (17 lb-ft)
Throttle Plate Screws	2.0 N•m (17 lb-ft)
Mounting Stud Nuts Torque	17 N•m (12 lb-ft)

DIESEL ENGINE

Muffler-to-Manifold Nuts	28 N•m (20 lb-in.)
Thermostat Housing Cap Screw	9 N•m (78 lb-in.)
Nozzle Torque	50 N•m (37 lb-ft)
Piston and Connecting Rod Cap Screw	23 N•m (97 lb-in.)
Seal Case-to-Block Cap Screw	11 N•m (96 lb-in.)
Oil Pan-to-Seal Case Cap Screw	9 N•m (78 lb-in.)
Crankshaft Main Bearing Cap Screw	54 N•m (40 lb-ft)
Camshaft Mounting Cap Screw.	11 N•m (96 lb-in.)
Intake Manifold Cap Screws	11 N•m (96 lb-in.)
Exhaust Manifold Cap Screw/Nut	11 N•m (96 lb-in.)
Rocker Arm Cover Special Screw	18 N•m (160 lb-in.)
Rocker Arm Assembly Mounting Cap Screw and Nut.	26 N•m (19 lb-ft)
Cylinder Head Cap Screws (Final)	34 N•m (25 lb-ft.)
Oil Pump Mounting Cap Screw	25 N•m (18 lb-ft)
Flywheel Cap Screws	83 N•m (61 lb-ft)
Flywheel Plate Mounting Cap Screw.	49 N•m (36 lb-ft)

Cooling System:

Coolant Pump Mounting Cap Screws	26 N•m (19 lb-ft)
Cooling Fan Mounting Cap Screw	11 N•m (96 lb-in.)
Coolant Pump Plate-to-Housing Screw.	9 N•m (78 lb-in.)

Fuel Injection:

Pump Mounting Nut	20 N•m (180 lb-in.)
Pump Camshaft Bearing Retaining Screw	20 N•m (180 lb-in.)
Mounting Nut	40 N•m (30 lb-ft)
Nozzle Fitting	40 N•m (30 lb-ft)

Oil Pan and Strainer:

Oil Pan-to-Block Mounting Cap Screw	11 N•m (96 lb-in.)
Oil Pan-to-Seal Case Mounting Cap Screw	9 N•m (78 lb-in.)
Oil Pan-to-Timing Gear Housing Mounting Cap Screw.	9 N•m (78 lb-in.)
Oil Strainer--to-Block Cap Screws Mounting Cap Screw	11 N•m (96 lb-in.)

Timing Gear Cover and Housing:

Fan Mounting Cap Screw	11 N•m (96 lb-in.)
Cover Mounting Cap Screw	9 N•m (78 lb-in.)
Crankshaft Pulley Cap Screw	115 N•m (85 lb-ft)
Aluminum Housing-to-Block	9 N•m (78 lb-in.)
Cast Iron Housing-to-Block.	11 N•m (96 lb-in.)

Alternators:

Flywheel Assembly-to-Coil Plate Assembly Nut (KoKosan 20A).	27 N•m (20 lb-ft)
Retainer-to-Front Frame Screw (Nippeondenso 40A).	2 N•m (16 lb-in.)
Sheave Nut (Nippeondenso 40A)	69 N•m (51 lb-ft)

POWER TRAIN, HYDROSTATIC

Control Arm Cap Screw	73 N•m (54 lb-ft)
Axle Housing Cap Screws Torque	54 N•m (40 lb-ft)
King Pin Cap Screws Torque	54 N•m (40 lb-ft)
Transaxle to Frame Mounting Cap Screws	88 N•m (65 lb-ft)
Differential Bolts	78—98 N•m (58—72 lb-ft)



PTO:

Solenoid Armature	22 N•m (195 lb-in.)
Solenoid Nut	4.9 N•m (43 lb-in.)
Output Shaft Retaining Cap Screws	27 N•m (20 lb-ft)
Shifter Shaft Cap Screw	25 N•m (18 lb-ft)
Ball Switches	34 N•m (25 lb-ft)

Charge Pump Cap Screws:

Short Cap Screws Torque	25 N•m (18 lb-ft)
Long Cap Screw Torque	39 N•m (29 lb-ft)

Hydrostatic Center Valve Block:

Directional Control Valves	35 N•m (26 lb-ft)
Bottom Suction Plug	50 N•m (37 lb-ft)
Implement Relief Valve Plug	25 N•m (18 lb-ft)
Mounting Cap Screws	39 N•m (29 lb-ft)

STEERING

Steering Wheel Nut	38 N•m (28 lb-ft)
Steering Valve End Cover Cap Screw	17 N•m (150 lb-in.)
Check Ball Plug	17 N•m (150 lb-in.)
Front Axle Pivot Cap Screw and Lock Nut	68 N•m (50 lb-ft)
Tie Rod Lock Nut	61 N•m (45 lb-ft)
Rear Steering Linkage Lock Nut	170 N•m (125 lb-ft)
Adjusting Nut Jam Nuts	68 N•m (50 lb-ft)
Rear Steering Side Pivots Pivot Lock Nut	108 N•m (80 lb-ft)
Mounting Cap Screw and Nut	84 N•m (62 lb-ft)
Rear Axle Pivot Bracket Cap Screws	91 N•m (67 lb-ft)
Pivot Nut	67—83 N•m (49—61 lb-ft)
Ball Joint Castellated Nut	45—57 N•m (33—42 lb-ft)

BRAKES

Transaxle Brake Cover Cap Screws Used Transaxle Case	25 N•m (18 lb-ft)
New Transaxle Case	30 N•m (22 lb-ft)
Brake Switch Striker	12 N•m (108 lb-in.)

HYDRAULICS

Return Spring Bonnet Retaining Screw	2.7—4 N•m (24—36 lb-in.)
Return Spring Caps Retaining Screw	2.7—4 N•m (24—36 lb-in.)
Detent Ball Retaining Screw	2.7—4 N•m (24—36 lb-in.)
Work Port Cap	34—40.7 N•m (25—30 lb-ft)
Lift Check Valves Cap Screw	20—27 N•m (15—20 lb-ft)

METRIC FASTENER TORQUE VALUES



Property Class and Head Markings	4.8		8.8		9.8		10.9		12.9	
Property Class and Nut Markings	5		10		10		10		12	

TS1163

SIZE	Class 4.8				Class 8.8 or 9.8				Class 10.9				Class 12.9			
	Lubricated ^a		Dry ^a		Lubricated ^a		Dry ^a		Lubricated ^a		Dry ^a		Lubricated ^a		Dry ^a	
	N•m	lb-ft	N•m	lb-ft	N•m	lb-ft	N•m	lb-ft	N•m	lb-ft	N•m	lb-ft	N•m	lb-ft	N•m	lb-ft
M6	48	3.5	6	4.5	9	6.5	11	8.5	13	9.5	17	12	15	11.5	19	14.5
M8	12	8.5	15	11	22	16	28	20	32	24	40	30	37	28	47	35
M10	23	17	29	21	43	32	55	40	63	47	80	60	75	55	95	70
M12	40	29	50	37	75	55	95	70	110	80	140	105	130	95	165	120
M14	63	47	80	60	120	88	150	110	175	130	225	165	205	150	260	109
M16	100	73	125	92	190	140	240	175	275	200	350	225	320	240	400	300
M18	135	100	175	125	260	195	330	250	375	275	475	350	440	325	560	410
M20	190	140	240	180	375	275	475	350	530	400	675	500	625	460	800	580
M22	260	190	330	250	510	375	650	475	725	540	925	675	850	625	1075	800
M24	330	250	425	310	650	475	825	600	925	675	1150	850	1075	800	1350	1000
M27	490	360	625	450	950	700	1200	875	1350	1000	1700	1250	1600	1150	2000	1500
M30	675	490	850	625	1300	950	1650	1200	1850	1350	2300	1700	2150	1600	2700	2000
M33	900	675	1150	850	1750	1300	2200	1650	2500	1850	3150	2350	2900	2150	3700	2750
M36	1150	850	1450	1075	2250	1650	2850	2100	3200	2350	4050	3000	3750	2750	4750	3500

DO NOT use these hand torque values if a different torque value or tightening procedure is given for a specific application. Torque values listed are for general use only and include a ±10% variance factor. Check tightness of fasteners periodically. DO NOT use air powered wrenches.

Shear bolts are designed to fail under predetermined loads. Always replace shear bolts with identical grade.

Fasteners should be replaced with the same grade. Make sure fastener threads are clean and that you properly start thread engagement. This will prevent them from failing when tightening.

When bolt and nut combination fasteners are used, torque values should be applied to the **NUT** instead of the bolt head.











Tighten toothed or serrated-type lock nuts to the full torque value.

^a "Lubricated" means coated with a lubricant such as engine oil, or fasteners with phosphate and oil coatings. "Dry" means plain or zinc plated (yellow dichromate - Specification JDS117) without any lubrication.

Reference: JDS—G200.

INCH FASTENER TORQUE VALUES



SAE Grade and Head Markings	1 or 2 ^b No Marks 	5  5.1  5.2 	8  8.2 
	2 No Marks 	5  	8  

TS1162

SIZE	Grade 1		Grade 2 ^b		Grade 5, 5.1 or 5.2				Grade 8 or 8.2							
	Lubricated ^a		Dry ^a		Lubricated ^a		Dry ^a		Lubricated ^a		Dry ^a		Lubricated ^a		Dry ^a	
	N•m	lb-ft	N•m	lb-ft	N•m	lb-ft	N•m	lb-ft	N•m	lb-ft	N•m	lb-ft	N•m	lb-ft	N•m	lb-ft
1/4	3.7	2.8	4.7	3.5	6	4.5	7.5	5.5	9.5	7	12	9	13.5	10	17	12.5
5/16	7.7	5.5	10	7	12	9	15	11	20	15	25	18	28	21	35	26
3/8	14	10	17	13	22	16	27	20	35	26	44	33	50	36	63	46
7/16	22	16	28	20	35	26	44	32	55	41	70	52	80	58	100	75
1/2	33	25	42	31	53	39	67	50	85	63	110	80	120	90	150	115
9/16	48	36	60	45	75	56	95	70	125	90	155	115	175	130	225	160
5/8	67	50	85	62	105	78	135	100	170	125	215	160	215	160	300	225
3/4	120	87	150	110	190	140	240	175	300	225	375	280	425	310	550	400
7/8	190	140	240	175	190	140	240	175	490	360	625	450	700	500	875	650
1	290	210	360	270	290	210	360	270	725	540	925	675	1050	750	1300	975
1-1/8	470	300	510	375	470	300	510	375	900	675	1150	850	1450	1075	1850	1350
1-1/4	570	425	725	530	570	425	725	530	1300	950	1650	1200	2050	1500	2600	1950
1-3/8	750	550	950	700	750	550	950	700	1700	1250	2150	1550	2700	2000	3400	2550
1-1/2	1000	725	1250	925	990	725	1250	930	2250	1650	2850	2100	3600	2650	4550	3350

DO NOT use these hand torque values if a different torque value or tightening procedure is given for a specific application. Torque values listed are for general use only and include a ±10% variance factor. Check tightness of fasteners periodically. DO NOT use air powered wrenches.

Shear bolts are designed to fail under predetermined loads. Always replace shear bolts with identical grade.

Fasteners should be replaced with the same grade. Make sure fastener threads are clean and that you properly start thread engagement. This will prevent them from failing when tightening.

When bolt and nut combination fasteners are used, torque values should be applied to the **NUT** instead of the bolt head.

Tighten toothed or serrated-type lock nuts to the full torque value.

^a "Lubricated" means coated with a lubricant such as engine oil, or fasteners with phosphate and oil coatings. "Dry" means plain or zinc plated (yellow dichromate - Specification JDS117) without any lubrication.

^b "Grade 2" applies for hex cap screws (not hex bolts) up to 152 mm (6-in.) long. "Grade 1" applies for hex cap screws over 152 mm (6-in.) long, and for all other types of bolts and screws of any length.

Reference: JDS—G200.

O-RING SEAL SERVICE RECOMMENDATIONS

FACE SEAL FITTINGS WITH INCH
STUD ENDS TORQUE

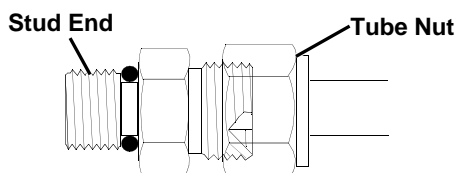

Stud Straight and Tube Nut

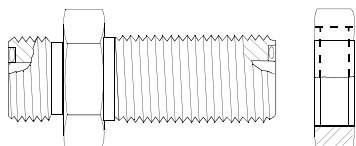

Bulkhead Union and Bulkhead Locknut

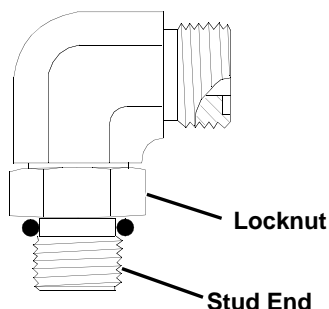

90 Adjustable Stud Elbow

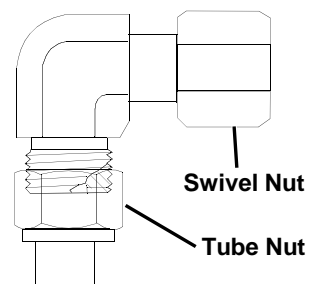

90 Swivel Elbow and Tube Nut

Nominal Tube O.D./Hose I.D.				Face Seal Tube/Hose End					O-ring Stud Ends		
Metric Tube O.D.	Inch Tube O.D.			Thread Size	Tube Nut/ Swivel Nut Torque		Bulkhead Locknut Torque		Thread Size	Straight Fitting or Locknut Torque	
	mm	Dash Size	in.		mm	in.	N•m	lb-ft		N•m	lb-ft
	-3	0.188	4.76						3/8-24	8	6
6	-4	0.250	6.35	9/16-18	16	12	12	9	7/16-20	12	9
8	-5	0.312	7.94						1/2-20	16	12
10	-6	0.375	9.52	11/16-16	24	18	24	18	9/16-18	24	18
12	-8	0.500	12.70	13/16-16	50	37	46	34	3/4-16	46	34
16	-10	0.625	15.88	1-14	69	51	62	46	7/8-14	62	46
	-12	0.750	19.05	1-3/16-12	102	75	102	75	1-1/16-12	102	75
22	-14	0.875	22.22	1-3/16-12	102	75	102	75	1-3/16-12	122	90
25	-16	1.000	25.40	1-7/16-12	142	105	142	105	1-5/16-12	142	105
32	-20	1.25	31.75	1-11/16-12	190	140	190	140	1-5/8-12	190	140
38	-24	1.50	38.10	2-12	217	160	217	160	1-7/8-12	217	160

NOTE: Torque tolerance is +15 / -20%.

FACE SEAL FITTINGS WITH METRIC STUD ENDS TORQUE

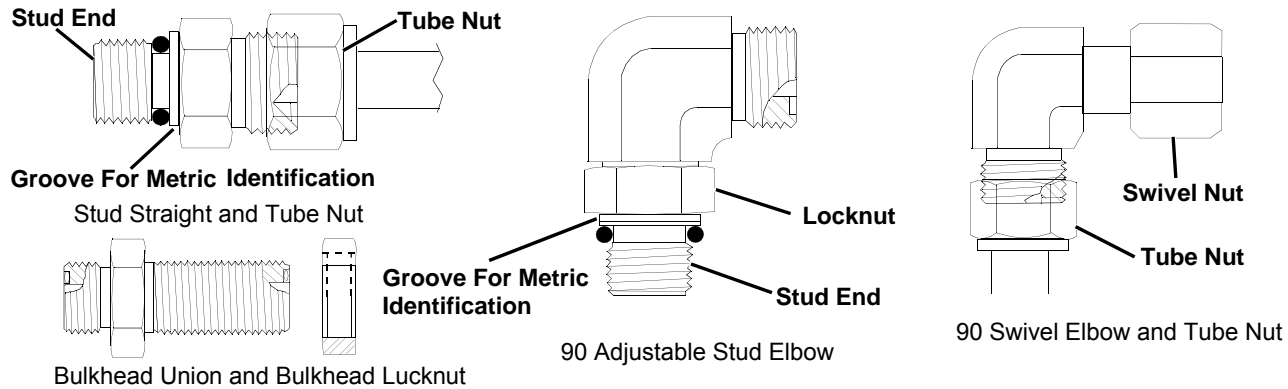

Nominal Tube O.D./Hose I.D.				Face Seal Tube/Hose End						O-ring Stud Ends, Straight Fitting or Locknut					
Metric Tube O.D.	Inch Tube O.D.			Thread Size	Hex Size	Tube Nut/ Swivel Nut Torque		Bulkhead Locknut Torque		Thread Size	Hex Size	Steel or Gray Iron Torque		Aluminum Torque	
	mm	Dash Size	in.			mm	in.	N•m	lb-ft			N•m	lb-ft	mm	mm
6	-4	0.250	6.35	9/16-18	17	16	12	12	9	M12X1.5	17	21	15.5	9	6.6
8	-5	0.312	7.94												
										M14X1.5	19	33	24	15	11
10	-6	0.375	9.52	11/16-16	22	24	18	24	18	M16X1.5	22	41	30	18	13
12	-8	0.500	12.70	13/16-16	24	50	37	46	34	M18X1.5	24	50	37	21	15
16	-10	0.625	15.88	1-14	30	69	51	62	46	M22X1.5	27	69	51	28	21
	-12	0.750	19.05	1-3/16-12	36	102	75	102	75	M27X2	32	102	75	46	34
22	-14	0.875	22.22	1-3/16-12	36	102	75	102	75	M30X2	36				
25	-16	1.000	25.40	1-7/16-12	41	142	105	142	105	M33X2	41	158	116	71	52
28										M38X2	46	176	130	79	58
32	-20	1.25	31.75	1-11/16-12	50	190	140	190	140	M42X2	50	190	140	85	63
38	-24	1.50	38.10	2-12	60	217	160	217	160	M48X2	55	217	160	98	72

NOTE: Torque tolerance is +15 / -20%.

O-RING FACE SEAL FITTINGS

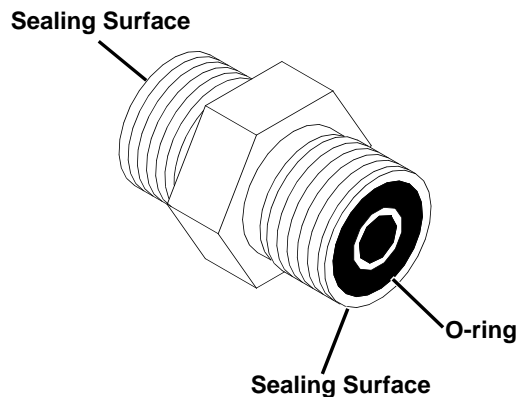

1. Inspect the fitting sealing surfaces. They must be free of dirt or defects.
2. Inspect the O-ring. It must be free of damage or defects.
3. Lubricate O-rings and install into groove using petroleum jelly to hold in place.
4. Push O-ring into the groove with plenty of petroleum jelly so O-ring is not displaced during assembly.
5. Index angle fittings and tighten by hand pressing joint together to insure O-ring remains in place.
6. Tighten fitting or nut to torque value shown on the chart per dash size stamped on the fitting. Do not allow hoses to twist when tightening fittings.

O-RING BOSS FITTINGS

1. Inspect boss O-ring boss seat. It must be free of dirt and defects. If repeated leaks occur, inspect for defects with a magnifying glass. Some raised defects can be removed with a slip stone.

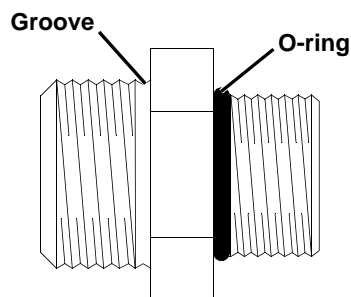

2. Put hydraulic oil or petroleum jelly on the O-ring. Place electrical tape over the threads to protect O-ring from nicks. Slide O-ring over the tape and into the groove of fitting. Remove tape.

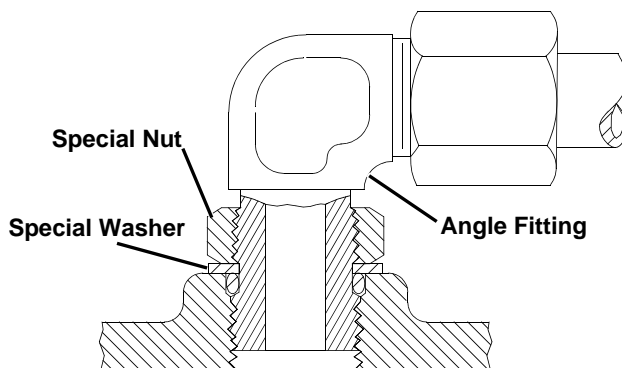

3. For angle fittings, loosen special nut and push special washer against threads so O-ring can be installed into the groove of fitting.
4. Turn fitting into the boss by hand until special washer or washer face (straight fitting) contacts boss face and O-ring is squeezed into its seat.
5. To position angle fittings, turn the fitting counter-clockwise a maximum of one turn.
6. Tighten straight fittings to torque value shown on chart. For angle fittings, tighten the special nut to value shown in the chart while holding body of fitting with a wrench.

STRAIGHT FITTING OR SPECIAL NUT TORQUES

Thread Size	Torque ^a		Number of Flats ^b
	N•m	lb-ft	
3/8-24 UNF	8	(6)	2
7/16-20 UNF	12	(9)	2
1/2-20 UNF	16	(12)	2
9/16-18 UNF	24	(18)	2
3/4-16 UNF	46	(34)	2
7/8-14 UNF	62	(46)	1-1/2
1-1/16-12 UN	102	(75)	1
1-3/16-12 UN	122	(90)	1
1-5/16-12 UN	142	(105)	3/4
1-5/8-12 UN	190	(140)	3/4
1-7/8-12 UN	217	(160)	1/2

a. Torque tolerance is ± 10 percent.

b. To be used if a torque wrench cannot be used. After tightening fitting by hand, put a mark on nut or boss; then tighten special nut or straight fitting the number of flats shown.

METRIC FASTENER TORQUE VALUE—GRADE 7 (SPECIAL)

Size	Steel or Gray Iron Torque		Aluminum Torque	
	N•m	lb-ft	N•m	lb-ft
M6	11	8	8	6
M8	24	18	19	14
M10	52	38	41	30
M12	88	65	70	52
M14	138	102	111	82
M16	224	165	179	132



GASOLINE 4-CYCLE ENGINES

c CAUTION

Gasoline is **HIGHLY FLAMMABLE**, handle it with care.

DO NOT refuel machine while:

- indoors, always fill gas tank outdoors;
- machine is near an open flame or sparks;
- engine is running, **STOP** engine;
- engine is hot, allow it to cool sufficiently first;
- smoking.

Help prevent fires:

- fill gas tank to bottom of filler neck only;
- be sure fill cap is tight after fueling;
- clean up any gas spills **IMMEDIATELY**;
- keep machine clean and in good repair—free of excess grease, oil, debris, and faulty or damaged parts;
- any storage of machines with gas left in tank should be in an area that is well ventilated to prevent possible igniting of fumes by an open flame or spark, this includes any appliance with a pilot light.

To prevent fire or explosion caused by **STATIC ELECTRIC DISCHARGE** during fueling:

- **ONLY** use a clean, approved **POLYETHYLENE PLASTIC** fuel container and funnel **WITHOUT** any metal screen or filter.

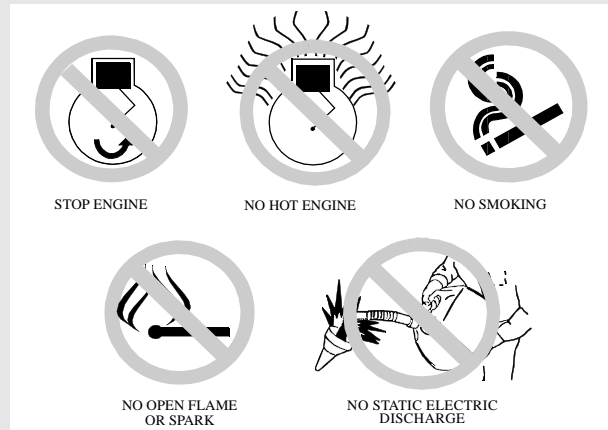

To avoid engine damage:

- DO NOT mix oil with gasoline;
- **ONLY** use clean, fresh unleaded gasoline with an octane rating (anti-knock index) of 87 or higher;
- fill gas tank at the end of each day's operation to help prevent condensation from forming inside a partially filled tank;
- keep up with specified service intervals.

Use of alternative oxygenated, gasohol blended, unleaded gasoline is acceptable as long as:

- the ethyl or grain alcohol blends DO NOT exceed 10% by volume or
- methyl tertiary butyl ether (MTBE) blends DO NOT exceed 15% by volume

RFG (reformulated) gasoline is acceptable for all tractors designed for use of regular unleaded fuel. Older tractors (that were designed for leaded fuel) may see some accelerated valve and seat wear.

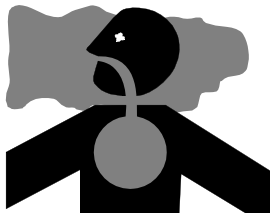

IMPORTANT: DO NOT use **METHANOL** gasolines because **METHANOL** is harmful to the environment and to your health.

c WARNING

California Proposition 65 Warning: Gasoline engine exhaust from this product contains chemicals known to the State of California to cause cancer, birth defects, or other reproductive harm.

GASOLINE STORAGE

IMPORTANT: Keep all dirt, scale, water or other foreign material out of gasoline.

Keep gasoline stored in a safe, protected area. Storage of gasoline in a clean, properly marked ("**UNLEADED GASOLINE**") **POLYETHYLENE PLASTIC** container **WITHOUT** any metal screen or filter is recommended. **DO NOT** use de-icers to attempt to remove water from gasoline or depend on fuel filters to remove water from gasoline. Use a water separator installed in the storage tank outlet. **BE SURE** to properly discard unstable or contaminated gasoline. When storing unit or gasoline, it is recommended that you add **John Deere Gasoline Conditioner and Stabilizer (TY15977)** or an equivalent to the gasoline. **BE SURE** to follow directions on container and to properly discard empty container.

DIESEL FUEL

In general, diesel fuels are blended to satisfy the low air temperature requirements of the geographical area in which they are sold.

In North America, diesel fuel is usually specified to **ASTM D975** and sold as either **Grade 1** for cold air temperatures or **Grade 2** for warm air temperatures.

If diesel fuels being supplied in your area **DO NOT** meet any of the above specifications, use diesel fuels with the following equivalent properties:

- Cetane Number 40 (minimum)
A cetane number **greater than 50 is preferred**, especially for air temperatures below -20°C (-4°F) or elevations above 1500 m (5000 ft).
- Cold Filter Plugging Point (CFPP)
The air temperature at which diesel fuel **begins to cloud or jell** — at least 5°C (9°F) below the expected low air temperature range.
- Sulfur Content of 0.05%
Diesel fuels for highway use in the United States now require sulfur content to be **less than 0.05%**.
If diesel fuel being used has a sulfur content **greater than 0.05%**, **reduce the service interval** for engine oil and filter by **50%**.

Consult your local diesel fuel distributor for properties of the diesel fuel available in your area.

c WARNING

California Proposition 65 Warning: Diesel engine exhaust and some of its elements from this product are known to the State of California to cause cancer, birth defects, or other reproductive harm.

DIESEL FUEL LUBRICITY

Diesel fuel must have adequate lubricity to ensure proper operation and durability of fuel injection system components. Fuel lubricity should pass a **minimum of 3300 gram load level** as measured by the **BOCLE** scuffing test.

DIESEL FUEL STORAGE

IMPORTANT: DO NOT USE GALVANIZED CONTAINERS—diesel fuel stored in galvanized containers reacts with zinc coating in the container to form zinc flakes. If fuel contains water, a zinc gel will also form. The gel and flakes will quickly plug fuel filters and damage fuel injectors and fuel pumps.



It is recommended that diesel fuel be stored **ONLY** in a clean, approved **POLYETHYLENE PLASTIC** container **WITHOUT** any metal screen or filter. This will help prevent any accidental sparks from occurring. Store fuel in an area that is well ventilated to prevent possible igniting of fumes by an open flame or spark, this includes any appliance with a pilot light.

IMPORTANT: Keep all dirt, scale, water or other foreign material out of fuel.

Keep fuel in a safe, protected area and in a clean, properly marked (“**DIESEL FUEL**”) container. **DO NOT** use deicers to attempt to remove water from fuel. **DO NOT** depend on fuel filters to remove water from fuel. It is recommended that a water separator be installed in the storage tank outlet. **BE SURE** to properly discard unstable or contaminated diesel fuel and/or their containers when necessary.

ENGINE OIL SPECIFICATIONS

4-CYCLE DIESEL ENGINE OIL



Use the appropriate oil viscosity based on the expected air temperature range during the period between recommended oil changes. Operating outside of these recommended oil air temperature ranges may cause premature engine failure.

The following John Deere oils are **PREFERRED**:

- **PLUS-50®—SAE 15W-40;**
- **TORQ-GARD SUPREME®—SAE 5W-30.**

The following John Deere oils are **also recommended**, based on their specified temperature range:

- **TURF-GARD®—SAE 10W-30;**
- **PLUS-4®—SAE 10W-30;**
- **TORQ-GARD SUPREME®—SAE 30.**

Other oils may be used if above John Deere oils are not available, provided they meet one of the following specifications:

- SAE 15W-40—API Service Classifications CF-4 or higher;
- SAE 5W-30—API Service Classification CC or higher;
- SAE 10W-30—API Service Classification CF or higher;
- SAE 30—API Service Classification CF or higher.

IMPORTANT: If diesel fuel with sulfur content greater than 0.5% is used, reduce the service interval for oil and filter by 50%.

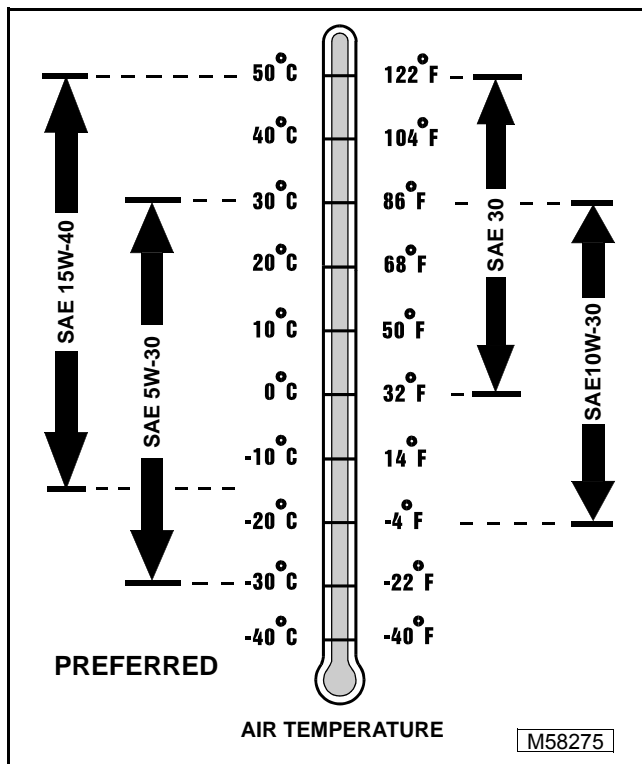

4-CYCLE GASOLINE ENGINE OIL

Use the appropriate oil viscosity based on the expected air temperature range during the period between recommended oil changes. Operating outside of these recommended oil air temperature ranges may cause premature engine failure.

The following John Deere oils are **PREFERRED**:

- **PLUS-4®—SAE 10W-40;**
- **TORQ-GARD SUPREME®—SAE 5W-30.**

The following John Deere oils are **also recommended**, based on their specified temperature range:

- **TURF-GARD®—SAE 10W-30;**
- **PLUS-4®—SAE 10W-30;**
- **TORQ-GARD SUPREME®—SAE 30.**

Other oils may be used if above John Deere oils are not available, provided they meet one of the following specifications:

- SAE 10W-40—API Service Classifications SG or higher;
- SAE 5W-30—API Service Classification SG or higher;
- SAE 10W-30—API Service Classifications SG or higher;
- SAE 30—API Service Classification SC or higher.

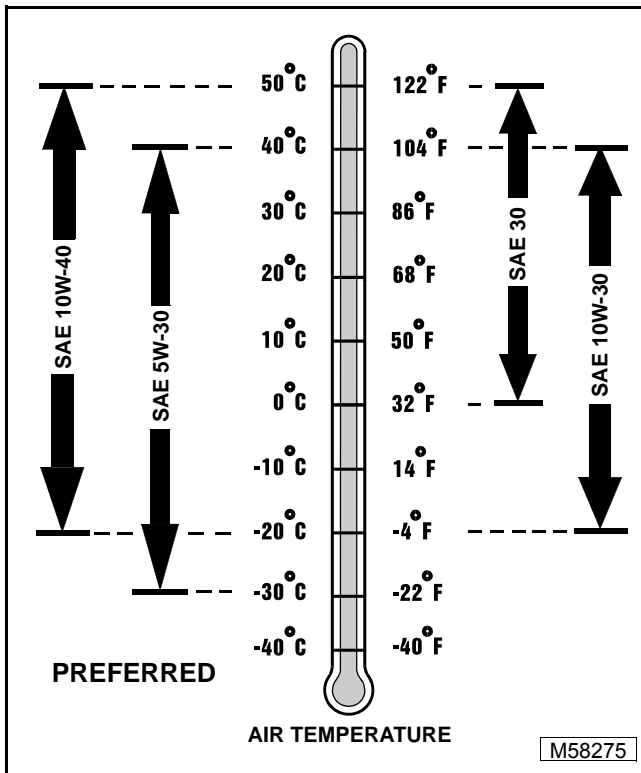

BREAK-IN ENGINE OIL—DIESEL



IMPORTANT: ONLY use this specified break-in oil in rebuilt or remanufactured engines for the first 100 hours (maximum) of operation. DO NOT use PLUS-50®, SAE 15W40 oil or oils meeting specifications API CG-4 or API CF-4, these oils will not allow rebuilt or remanufactured engines to break-in properly.

The following John Deere oil is **PREFERRED**:

- **BREAK-IN ENGINE OIL.**

John Deere BREAK-IN ENGINE OIL is formulated with special additives for aluminum and cast iron type engines to allow the power cylinder components (pistons, rings, and liners as well) to “wear-in” while protecting other engine components, valve train and gears, from abnormal wear. Engine rebuild instructions should be followed closely to determine if special requirements are necessary.

John Deere BREAK-IN ENGINE OIL is also recommended for non-John Deere engines, both aluminum and cast iron types.

If this preferred John Deere oil is not available, use a break-in engine oil meeting the following specification during the first 100 hours of operation:

- API Service Classification CE or higher.

IMPORTANT: After the break-in period, use the John Deere oil that is recommended for this engine.

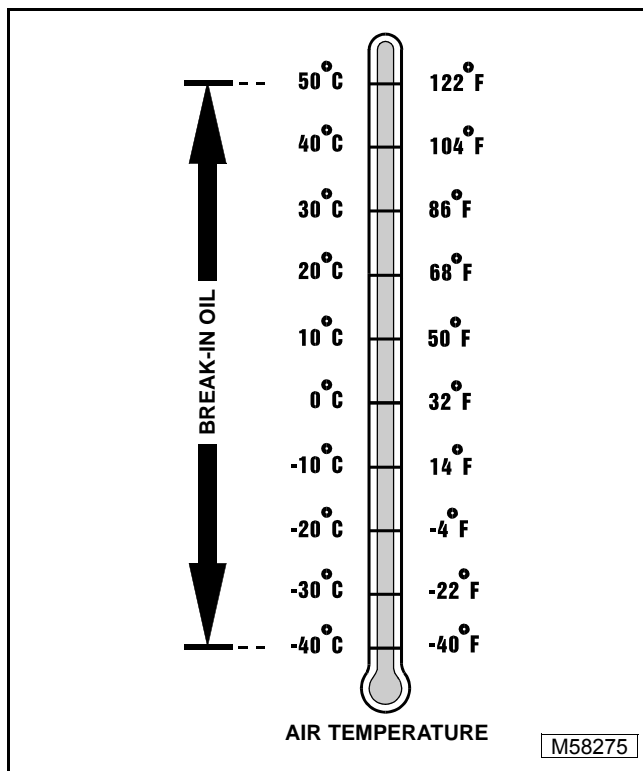

BREAK-IN ENGINE OIL—4-CYCLE GASOLINE

IMPORTANT: ONLY use a quality break-in oil in rebuilt or remanufactured engines for the first 5 hours (maximum) of operation. DO NOT use oils with heavier viscosity weights than SAE 5W-30 or oils meeting specifications API SG or SH, these oils will not allow rebuilt or remanufactured engines to break-in properly.

The following John Deere oil is **PREFERRED**:

- **BREAK-IN ENGINE OIL.**

John Deere BREAK-IN ENGINE OIL is formulated with special additives for aluminum and cast iron type engines to allow the power cylinder components (pistons, rings, and liners as well) to “wear-in” while protecting other engine components, valve train and gears, from abnormal wear. Engine rebuild instructions should be followed closely to determine if special requirements are necessary.

John Deere BREAK-IN ENGINE OIL is also recommended for non-John Deere engines, both aluminum and cast iron types.

The following John Deere oil is **also recommended**:

- **TORQ-GARD SUPREME®—SAE 5W-30.**

If the above recommended John Deere oils are not available, use a break-in engine oil meeting the following specification during the first 5 hours (maximum) of operation:

- SAE 5W-30—API Service Classification SE or higher.

IMPORTANT: After the break-in period, use the John Deere oil that is recommended for this engine.

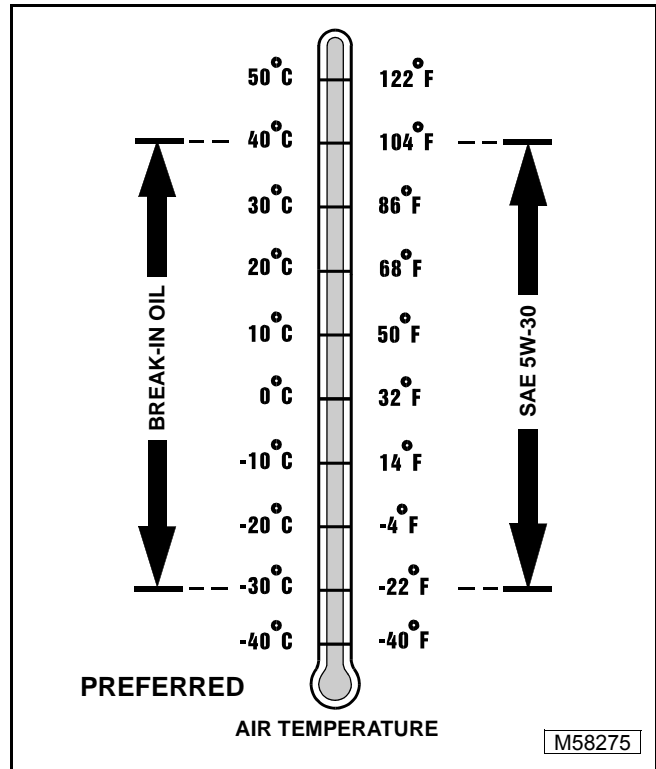

HYDROSTATIC TRANSMISSION AND HYDRAULIC OIL



HYDROSTATIC TRANSMISSION AND HYDRAULIC OIL

Use the appropriate oil viscosity based on these air temperature ranges. Operating outside of these recommended oil air temperature ranges may cause premature hydrostatic transmission or hydraulic system failures.

IMPORTANT: Mixing of **LOW VISCOSITY HY-GARD®** and **HY-GARD®** oils is permitted. **DO NOT** mix any other oils in this transmission. **DO NOT** use engine oil or “Type F” (Red) Automatic Transmission Fluid in this transmission. **DO NOT** use **BIO-HY-GARD®** in this transmission.

The following John Deere transmission and hydraulic oil is **PREFERRED**:

- **LOW VISCOSITY HY-GARD®—JDM J20D.**

The following John Deere oil is **also recommended** if above preferred oil is not available:

- **HY-GARD®—JDM J20C.**

Other oils may be used if above recommended John Deere oils are not available, provided they meet one of the following specifications:

- John Deere Standard JDM J20D;
- John Deere Standard JDM J20C.

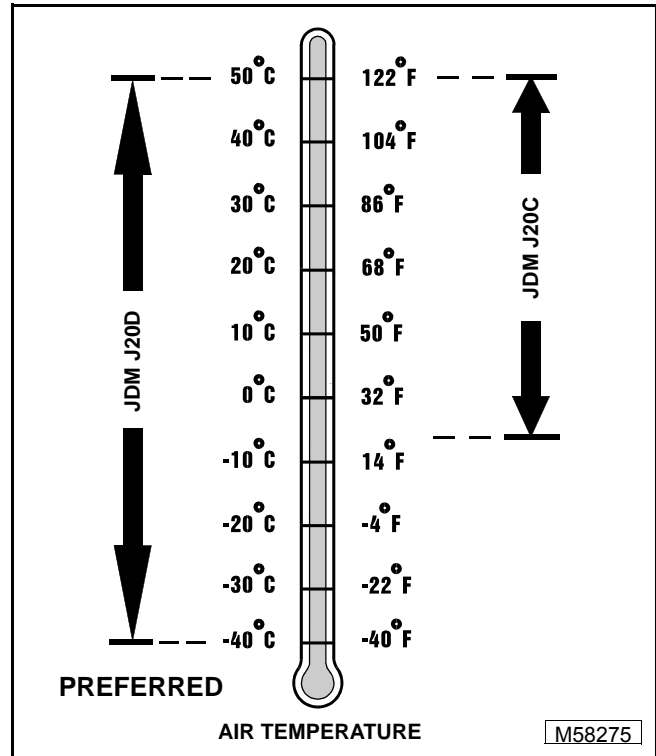

GEAR CASE OIL SPECIFICATIONS

GEAR CASE OIL

Use the appropriate oil viscosity based on the air temperature ranges. Operating outside of these recommended oil air temperature ranges may cause premature gear case failure.

IMPORTANT: ONLY use a quality oil in this gear case. DO NOT mix any other oils in this gear case. DO NOT use BIO-HY-GARD® in this gear case.

The following John Deere gear case oil is **PREFERRED**:

- **GL-5 GEAR LUBRICANT®—SAE 80W-90.**

The following John Deere gear case oil is **also recommended** if above preferred oil is not available:

- **GL-5 GEAR LUBRICANT®—SAE 85W-140.**

Other gear case oils may be used if above recommended John Deere gear case oils are not available, provided they meet the following specification:

- API Service Classification GL-5.

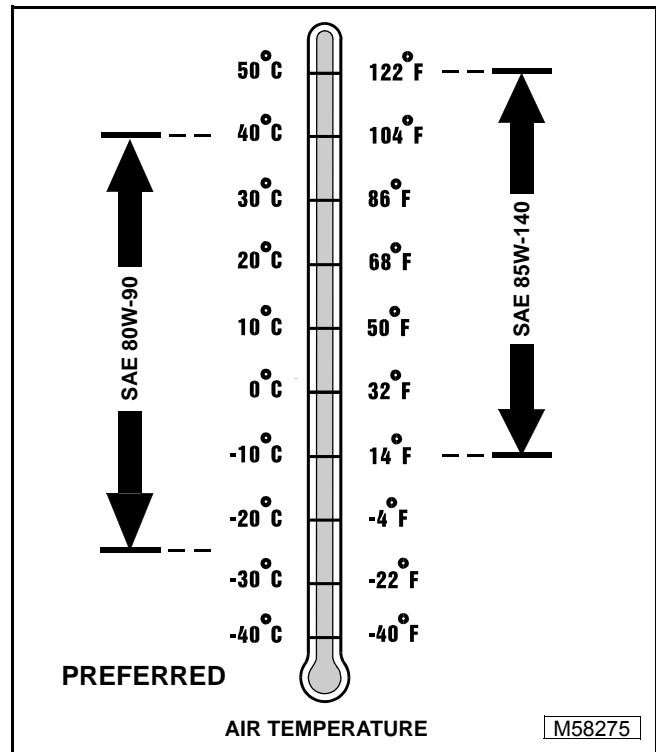

GEAR TRANSMISSION GREASE SPECIFICATIONS



GEAR TRANSMISSION GREASE

Use the following gear grease based on the air temperature range. Operating outside of the recommended grease air temperature range may cause premature gear transmission failure.

IMPORTANT: ONLY use a quality gear grease in this transmission. DO NOT mix any other greases in this transmission. DO NOT use any BIO-GREASE in this transmission.

The following John Deere gear grease is **PREFERRED**:

- **NON-CLAY HIGH-TEMPERATURE EP GREASE®—JDM J13E4, NLGI Grade 2.**

Other greases may be used if above preferred John Deere grease is not available, provided they meet the following specification:

- John Deere Standard JDM J13E4, NLGI Grade 2.

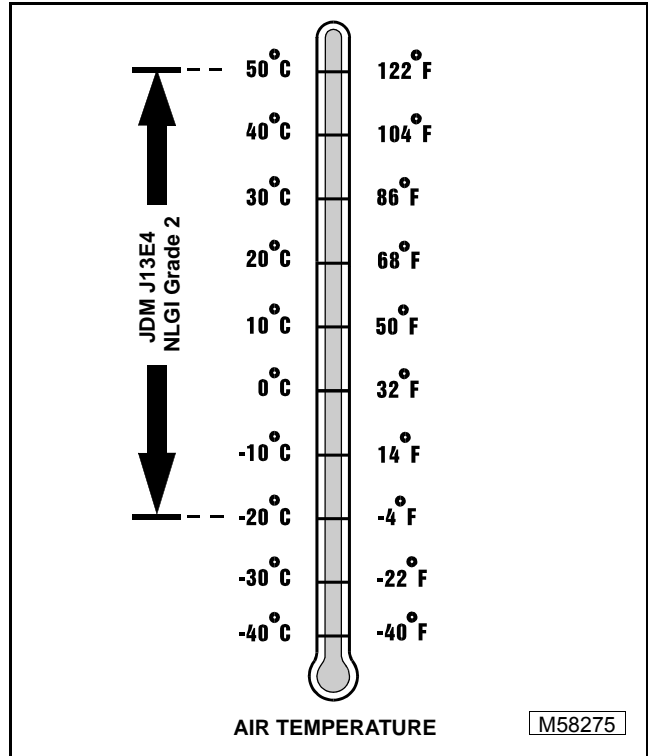

ALTERNATIVE LUBRICANTS

Use of alternative lubricants could cause reduced life of the component.

If alternative lubricants are to be used, it is recommended that the factory fill be thoroughly removed before switching to any alternative lubricant.

SYNTHETIC LUBRICANTS

Synthetic lubricants may be used in John Deere equipment if they meet the applicable performance requirements (industry classification and/or military specification) as shown in this manual.

The recommended air temperature limits and service or lubricant change intervals should be maintained as shown in the operator's manual, unless otherwise stated on lubricant label.

Avoid mixing different brands, grades, or types of oil. Oil manufacturers blend additives in their oils to meet certain specifications and performance requirements. Mixing different oils can interfere with the proper functioning of these additives and degrade lubricant performance.

LUBRICANT STORAGE

All machines operate at top efficiency only when clean lubricants are used. Use clean storage containers to handle all lubricants. Store them in an area protected from dust, moisture, and other contamination. Store drums on their sides. Make sure all containers are properly marked as to their contents. Dispose of all old, used containers and their contents properly.

MIXING OF LUBRICANTS

In general, avoid mixing different brands or types of lubricants. Manufacturers blend additives in their lubricants to meet certain specifications and performance requirements. Mixing different lubricants can interfere with the proper functioning of these additives and lubricant properties which will downgrade their intended specified performance.



OIL FILTERS

IMPORTANT: Filtration of oils is critical to proper lubrication performance. Always change filters regularly.

The following John Deere oil filters are PREFERRED:

- AUTOMOTIVE AND LIGHT TRUCK ENGINE OIL FILTERS.

Most John Deere filters contain pressure relief and anti-drainback valves for better engine protection.

Other oil filters may be used if above recommended John Deere oil filters are not available, provided they meet the following specification:

- ASTB Tested In Accordance With SAE J806.

COOLANT SPECIFICATIONS

DIESEL AND GASOLINE ENGINE COOLANT



The engine cooling system when filled with a proper dilution mixture of anti-freeze and deionized or distilled water provides year-round protection against corrosion, cylinder or liner pitting, and winter freeze protection down to -37°C (-34°F).

The following John Deere coolant is **PREFERRED**:

- **PRE-DILUTED DIESEL ENGINE ANTI-FREEZE/SUMMER COOLANT™ (TY16036).**

This coolant satisfies specifications for “Automobile and Light Duty Engine Service” and is safe for use in John Deere Lawn and Grounds Care/Golf and Turf Division equipment, including aluminum block gasoline engines and cooling systems.

The above preferred pre-diluted anti-freeze provides:

- adequate heat transfer
- corrosion-resistant chemicals for the cooling system
- compatibility with cooling system hose and seal material
- protection during extreme cold and extreme hot weather operations
- chemically pure water for better service life
- compliance with ASTM D4656 (JDM H24C2) specifications

If above preferred pre-diluted coolant is not available, the following John Deere concentrate is **recommended**:

- **DIESEL ENGINE ANTI-FREEZE/SUMMER COOLANT CONCENTRATE™ (TY16034).**

If either of above recommended engine coolants are available use any Automobile and Light Duty Engine Service **ethylene glycol base coolant**, meeting the following specification:

- ASTM D3306 (JDM H24C1).

Read container label completely before using and follow instructions as stated.

IMPORTANT: To prevent engine damage, **DO NOT** use pure anti-freeze or less than a 50% anti-freeze mixture in the cooling system. **DO NOT** mix or add any additives/conditioners to the cooling system in Lawn and Grounds Care/Golf and Turf Division equipment. Water used to dilute engine coolant concentrate must be of high quality—clean, clear, potable water (low in chloride and hardness—Table 1) is generally acceptable. **DO NOT** use salt water. Deionized or distilled water is ideal to use. Coolant that is not mixed to these specified levels and water purity can cause excessive scale, sludge deposits, and increased corrosion potential.

Water Quality

Property	Requirements
Total Solids, Maximum	340 ppm (20 grns/gal)
Total Hardness, Max.	170 ppm (10 grns/gal)
Chloride (as Cl), Max.	40 ppm (2.5 grns/gal)
Sulfate (as SO ₄), Max.	100 ppm (5.8 grns/gal)

Mix 50 percent anti-freeze concentrate with 50 percent distilled or deionized water. This mixture and the pre-diluted mixture (TY16036) will protect the cooling system down to -37°C (-34°F) and up to 108°C (226°F).

Certain geographical areas may require lower air temperature protection. See the label on your anti-freeze container or consult your John Deere dealer to obtain the latest information and recommendations.

DIESEL AND GASOLINE ENGINE COOLANT DRAIN INTERVAL

When using **John Deere Pre-Diluted (TY16036)** Automobile and Light Duty Engine Service coolants, drain and flush the cooling system and refill with fresh coolant mixture every **36 months or 3,000 hours** of operation, whichever comes first.

When using **John Deere Concentrate (TY16034)** Automobile and Light Duty Engine Service coolants, drain and flush the cooling system and refill with fresh coolant mixture every **24 months or 2,000 hours** of operation, whichever comes first.

If above John Deere Automobile and Light Duty Engine Service coolants **are not** being used; drain, flush, and refill the cooling system according to instructions found on product container or in equipment operator’s manual or technical manual.

SERIAL NUMBER LOCATIONS

PRODUCT SERIAL NUMBER

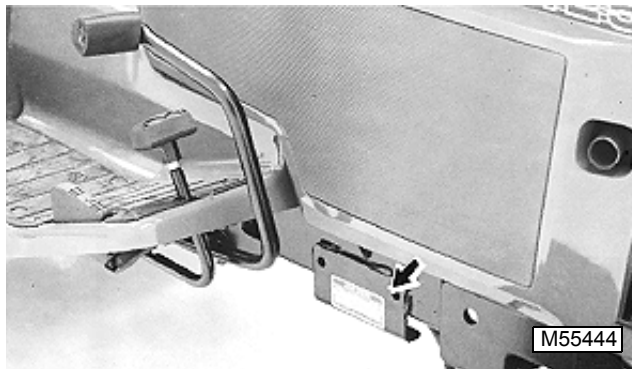

The 13-digit product identification number is located on the right-hand side frame, just below engine compartment.

DIESEL ENGINE SERIAL NUMBER LOCATION

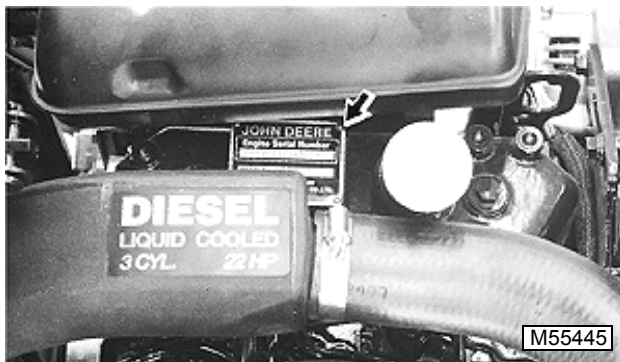

The engine serial number is located on valve cover. The model number will designate the engine type.

415 Export Model Number

..... 3TN66-UJ2 or 3007D002

455 Export (Early) Model Number 3TNA72-UJ2

455 Export (Late) Model Number3TNA72C-UJ2

455 Export (Homologated) Model Number

..... 3TNA72C-UJ2E

GASOLINE ENGINE SERIAL NUMBER LOCATION

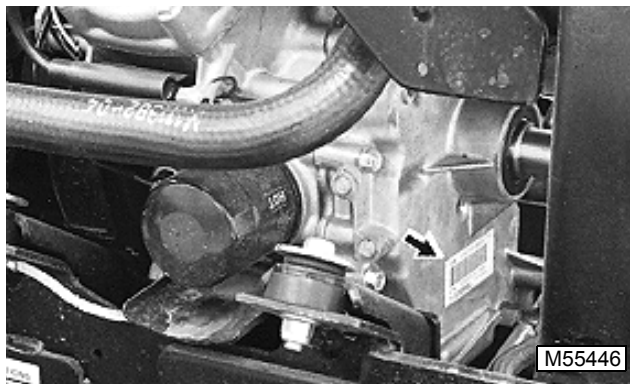

Engine serial number is located on the front of the engine.

TRANSAXLE SERIAL NUMBER LOCATION

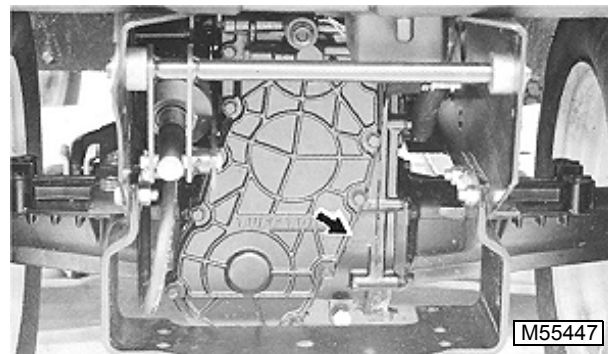

The transaxle serial number plate is located on right-hand flat surface under the operator's platform.





This page intentionally left blank.

CONTENTS

Page

ENGINE—FD620D, K SERIES

SPECIFICATIONS	3-3
TEST AND ADJUSTMENT SPECIFICATIONS	3-3
REPAIR SPECIFICATIONS	3-4
COMPONENT LOCATION	3-8
ENGINE—FD620D	3-8
THEORY OF OPERATION	3-9
COOLING SYSTEM OPERATION	3-9
CARBURETED ENGINE FUEL AND AIR SYSTEM OPERATION—425	3-10
FUEL INJECTION AIR SYSTEM COMPONENTS AND OPERATION—445	3-13
FUEL INJECTOR OPERATION—445	3-14
FUEL PRESSURE REGULATOR OPERATION—445	3-14
GOVERNOR OPERATION	3-15
LUBRICATION SYSTEM OPERATION	3-16
THROTTLE BODY OPERATION—445	3-17
TROUBLESHOOTING—425 CARBURETED ENGINES	3-18
TROUBLESHOOTING—425 CARBURETED ENGINES	3-22
TROUBLESHOOTING—445 FUEL INJECTED ENGINES	3-23
DIAGNOSIS—425	3-28
ENGINE SYSTEM DIAGNOSIS—425 CARBURETED ENGINES	3-28
ENGINE SYSTEM TEST POINTS—425 CARBURETED ENGINES	3-29
DIAGNOSIS—425	3-34
ENGINE SYSTEM DIAGNOSIS—445 FUEL INJECTED ENGINES	3-34
ENGINE SYSTEM TEST POINTS—445 FUEL INJECTED ENGINES	3-35
TESTS AND ADJUSTMENTS	3-40
THROTTLE LEVER ADJUSTMENT	3-40
THROTTLE CABLE ADJUSTMENT	3-40
CHOKE ADJUSTMENT	3-40
GOVERNOR ADJUSTMENT	3-41
SLOW IDLE ADJUSTMENT—425 NON-CARB/EPA ENGINES	3-41
FAST IDLE ADJUSTMENT	3-43
COMPRESSION TEST	3-44
VALVE CLEARANCE ADJUSTMENT	3-44
CRANKCASE VACUUM TEST	3-45
ENGINE OIL PRESSURE TEST (Engines With Oil Pressure Switch Ports)	3-45
ENGINE OIL PRESSURE TEST (Engines Without Oil Pressure Switch Ports)	3-46
FUEL PUMP FLOW TEST FOR CARBURETOR—425	3-47
FUEL PUMP PRESSURE TEST FOR CARBURETOR—425	3-47
FUEL PUMP PRESSURE TEST FOR FUEL INJECTION—445	3-48
FAN BELT TENSION ADJUSTMENT	3-48
RADIATOR BUBBLE TEST	3-49
RADIATOR CAP PRESSURE TEST	3-49
THERMOSTAT TEST	3-49
COOLING SYSTEM TEST	3-49



	Page
ENGINE OIL DIPSTICK	3-50
REPAIR	3-51
ENGINE—REMOVAL/INSTALLATION—425	3-51
ENGINE—REMOVAL/INSTALLATION (445)	3-52
CARBURETOR—EXPLODED VIEW	3-53
CARBURETOR—CLEAN AND REBUILD	3-54
COOLANT PUMP—REMOVAL/INSTALLATION	3-55
COOLING FAN AND BRACKET	3-56
FUEL INJECTOR—445	3-57
FUEL PRESSURE REGULATOR—445	3-57
FLYWHEEL—REMOVAL/INSTALLATION	3-57
GOVERNOR	3-58
THROTTLE BODY REPAIR—445	3-59
CYLINDER HEAD—REMOVAL	3-60
CYLINDER HEAD AND VALVE COMPONENTS	3-60
VALVE, VALVE SEAT, AND GUIDE—INSPECTION	3-61
PUSH ROD—INSPECTION	3-62
CYLINDER HEAD—INSTALLATION	3-63
CRANKCASE COVER—DISASSEMBLY	3-63
PISTONS—REMOVAL	3-63
PISTON RINGS—REMOVAL/INSTALLATION	3-64
PISTON RING END GAP	3-64
PISTON RING WEAR	3-64
PISTON—INSPECTION	3-65
CONNECTING ROD—INSPECTION	3-67
CRANKSHAFT AND CONNECTING ROD WEAR	3-67
CONNECTING ROD AND PISTON—ASSEMBLY	3-67
CAMSHAFT—REMOVAL/INSTALLATION	3-68
CAMSHAFT BEARINGS	3-69
TAPPETS—REMOVAL/INSTALLATION	3-69
CRANKSHAFT—REMOVAL	3-69
CRANKSHAFT—INSPECTION	3-69
CRANKSHAFT AND CONNECTING ROD WEAR	3-69
CRANKSHAFT—INSTALLATION	3-70
CRANKSHAFT PLAIN BEARINGS	3-70
CRANKSHAFT JOURNAL BUSHING AND SEALS—REPLACEMENT	3-71
CYLINDERS—BLOCK INSPECTION	3-71
CYLINDER BORE—DEGLAZING	3-72
CYLINDER BLOCK—REBORING	3-72
OIL PUMP—REMOVAL/INSTALLATION	3-72
OIL PUMP—DISASSEMBLY, INSPECTION AND ASSEMBLY	3-73



SPECIFICATIONS

TEST AND ADJUSTMENT SPECIFICATIONS

Engine

Oil Pressure Sensor Activates	98 kPa (14.2 psi)
Oil Pressure While Cranking (Minimum)	28 kPa (4 psi)
Oil Pressure	138—272 kPa (20—40 psi)
Oil Filter Bypass Valve Opening Pressure	78.5—117.5 kPa (11.4—17.1 psi)
Cylinder Compression Pressure (Minimum)	1171 kPa (170 psi)
Maximum Compression Pressure Variation Between Cylinders	97 kPa (14 psi)
Crankcase Vacuum (Minimum)25 mm (1 in.) water
Intake and Exhaust Valve Clearance (Cold)	0.25 mm (0.01 in.)
Intake and Exhaust Valve Adjustment Interval	300 hrs
Valve Clearance Adjusting Nut Torque	9 N•m (79 lb-in.)



Fuel/Air System

Fuel Pump

Minimum Flow—425	300 mL (10 oz) in 10 seconds
Minimum Pressure (Carburetor—425)	10 kPa (1.5 psi)
Minimum Pressure (Fuel Injection—445)	172—186 kPa (25—27 psi)

Carburetor

SLOW Idle Mixture Screw Initial Setting	1 turn counterclockwise after lightly seating
SLOW Idle Stop Screw Setting	50 rpm less than throttle control arm SLOW idle stop screw setting
Throttle Lever Friction Disks18—35 N (4—8 lb force)

Throttle Cable

Throttle Control Arm SLOW Idle Stop Screw Setting	1500 ± 100 rpm
Throttle Control Arm FAST Idle Stop Screw Setting	3600 ± 100 rpm
Air Restriction Indicator	(optional)

Fuel Tank

Check Valve Opening Pressure (Maximum)	3 kPa (0.4 psi)
--	-----------------

Cooling System

Radiator

Maximum Test Pressure	117 kPa (17 psi)
Minimum Hold Pressure	90 kPa (13 psi)

Radiator Cap

Opening Pressure	83—96 kPa (12—14 psi)
Minimum Pressure	76 kPa (11 psi)

Thermostat

Begin-to-Open Temperature	63—66°C (145—150°F)
Full-Open Temperature	80°C (176°F)
Full-Closed Temperature	63—66°C (145—150°F)

Fan Belt

Fan Belt Tension	12—19 mm (0.472—0.748 in.) deflection with 245—391 N (55—88 lb force) applied force
----------------------------	--

REPAIR SPECIFICATIONS

Engine

- Mounting Bolts Torque 80 N•m (60 lb-ft)
- Drive Shaft Coupler Screws Torque 40 N•m (30 lb-ft)

Carburetor—425



- Throttle Shaft Retaining Screw Torque 2.0 N•m (17 lb-in.)
- Drain Screw Torque 1.2 N•m (10 lb-in.)
- Choke and Throttle Plate Screws Torque 0.88 N•m (7.8 lb-in.)
- Solenoid Valve Torque 9.8 N•m (87 lb-in.)
- Main Jet and Main Air Jet Torque 1.0 N•m (8.9 lb-in.)
- Air Horn Mounting Screws Torque 2.9 N•m (26 lb-ft)

Throttle Body—445

- Throttle Shaft Retaining Screw Torque 2.0 N•m (17 lb-in.)
- Throttle Plate Screws Torque 0.88 N•m (7.8 lb-in.)
- Mounting Stud Nuts Torque 17 N•m (12 lb-ft)

Plain Bearings

- Maximum Crankcase Cover ID 34.07 mm (1.341 in.)
- Maximum Crankcase ID 34.11 mm (1.343 in.)

Crankcase

- Oil Capacity 1.5 L (3.2 pt)
- Cover Cap Screw Torque 21 N•m (186 lb-in.)
- Drain Plug Torque 23 N•m (204 lb-in.)
- Breather Reed Valve Clearance 0.2 mm (0.008 in.)

Fuel System

- Carburetor Mounting Nuts Torque 17 N•m (12 lb-ft)

Intake Manifold

- Cap Screw Torque 6 N•m (53 lb-in.)
- Pressure Relief Plug Torque 15 N•m 133 lb-in.)

Cylinder Head and Valves

- Valve Clearance 0.25 mm (0.010 in.)

Rocker Arm

- Minimum Shaft OD 11.95 mm (0.470 in.)
- Maximum Bearing ID 12.07 mm (0.475 in.)
- Adjuster Screw Lock Nut Torque 9 N•m (79 lb-in.)
- Push Rod Maximum Bend 0.80 mm (0.031 in.)

REPAIR SPECIFICATIONS—(continued)**Valves and Springs**

Valve Clearance at 16—27°C (60—80°F)	0.25 mm (0.010 in.)
Spring Free Length	29.70 mm (1.170 in.)
Minimum Valve Stem OD	
Intake	5.94 mm (0.234 in.)
Exhaust	5.92 mm (0.233 in.)
Maximum Valve Guide ID	6.05 mm (0.238 in.)
Maximum Valve Stem Bend	0.03 mm (0.001 in.)
Standard Valve Seating Surface	0.80 mm (0.031 in.)
Valve Seating Width Tolerance	0.50—1.10 mm (0.020—0.043 in.)
Valve Seat and Face Angle	45°
Minimum Valve Margin	0.60 mm (0.024 in.)
Valve Narrowing Angle	30°

Push Rods

Maximum Run-Out	0.8 mm (0.03 in.)
---------------------------	-------------------

Cylinder Head

Cylinder Head Flatness	0.06 mm (0.002 in.)
Cap Screw Torque in Sequence (Lubricated)	
Initial Torque	13 N•m (115 lb-in.)
Final Torque	21 N•m (186 lb-in.)
Spark Plug Torque	25 N•m (221 lb-in.)

Flywheel

Flywheel Nut Torque	108 N•m (80 lb-ft)
Flywheel Sheave Torque	15 N•m (130 lb-in.)
Fan Belt Tension Adjustment	
Increase	Remove shim(s)
Decrease	Add shim(s)
Fan Belt Drive Sheave Screw Torque	15 N•m (133 lb-in.)

Camshaft

Bearing Journals OD (Minimum)	15.91 mm (0.626 in.)
Minimum Lobe OD (Intake)	25.21 mm (0.993 in.)
Minimum Lobe OD (Exhaust)	25.46 mm (1.002 in.)
Minimum Fuel Pump Lobe	19.50 mm (0.760 in.)
Maximum Cover and Crankcase Bearing ID	16.07 mm (0.633 in.)



REPAIR SPECIFICATIONS—(continued)

Piston

Maximum Top Ring Groove Clearance	0.15 mm (0.006 in.)
Maximum Second Ring Groove Clearance	0.12 mm (0.005 in.)
Maximum Oil Ring Groove Clearance	Not measured
Maximum Ring End Gap	1.20 mm (0.050 in.)
Minimum Pin O.D.	16.98 mm (0.668 in.)
Maximum Pin Bore ID	17.04 mm (0.671 in.)
Distance from Bottom of Piston Skirt to Measure Piston OD	11 mm (0.433 in.)
Piston OD	75.935—75.950 mm (2.989—2.990 in.)
Piston-to-Cylinder Bore Clearance	0.030—0.170 mm (0.00118—0.00670 in.)

Connecting Rod

Maximum Crankshaft Bearing ID	34.06 mm (1.341 in.)
Maximum Piston Pin Bearing ID	17.05 mm (0.671 in.)
End-Cap Screw Torque	21 N•m (186 lb-in.)

Crankshaft

Minimum Bearing Journal OD	33.91 mm (1.335 in.)
Minimum Connecting Rod Journal	33.93 mm (1.336 in.)
Maximum T.I.R. (Bend)	0.05 mm (0.002 in.)

Crankshaft Plain Bearings

Maximum Crankcase Cover ID	34.07 mm (1.341 in.)
Maximum Crankcase ID	34.11 mm (1.343 in.)

Cylinder Bore

Standard ID	75.98—76.00 mm (2.994—2.995 in.)
Maximum ID	76.07 mm (2.997 in.)

Cylinder Block Reboring

Oversize Diameter 0.50 mm	76.46—76.48 mm (3.012—3.013 in.)
-------------------------------------	----------------------------------



REPAIR SPECIFICATIONS—(continued)

Oil Pump

Cover Cap Screws Torque	7.8 N•m (69 lb-in.)
Minimum Rotor Shaft OD	10.92 mm (0.430 in.)
Maximum Rotor Shaft Bearing ID	11.07 mm (0.436 in.)
Minimum Outer Rotor OD	40.43 mm (1.592 in.)
Maximum Outer Rotor Bearing ID	40.80 mm (1.606 in.)
Minimum Relief Valve Spring Free Length	19.50 mm (0.770 in.)
Maximum Inner and Outer Rotor Clearance	0.3 mm (0.012 in.)
Maximum Pump Housing Depth	10.230 mm (0.403 in.)
Maximum Outer Rotor Thickness	9.830 mm (0.3870 in.)



Coolant Pump

Minimum Shaft OD	9.94 mm (0.391 in.)
Maximum Pump and Crankcase Housing Bore ID	10.09 mm (0.397 in.)
Cap Screw Torque	9—11 N•m (79—96 lb-in.)
Crankcase Cover Cap Screw Torque	23—28 N•m (17—20 lb-ft)

Over-flow Reservoir

Mounting Cap Screw Torque	4 N•m (31 lb-in.)
-------------------------------------	-------------------

Governor

Governor Arm Nut Torque	7.88 N•m (69 lb-in.)
Shaft Oil Seal	1.0 mm (0.004 in.) below crankcase surface

Charging System

Capacity	20 amps
Unregulated Stator Output	26 VAC @ 3000 rpm
Regulated Stator Output	15 VDC @ 3000 rpm

Injector

Resistance at 20°C (68°F)	13.8 ohms
-------------------------------------	-----------

Ignition System

Pulser Output	0.1—1.0 VAC
-------------------------	-------------

Electric Starter

Minimum Brush Length	6 mm (0.240 in.)
Maximum No Load Starter Draw	30 amps at 6000 rpm (min)

COMPONENT LOCATION

ENGINE—FD620D

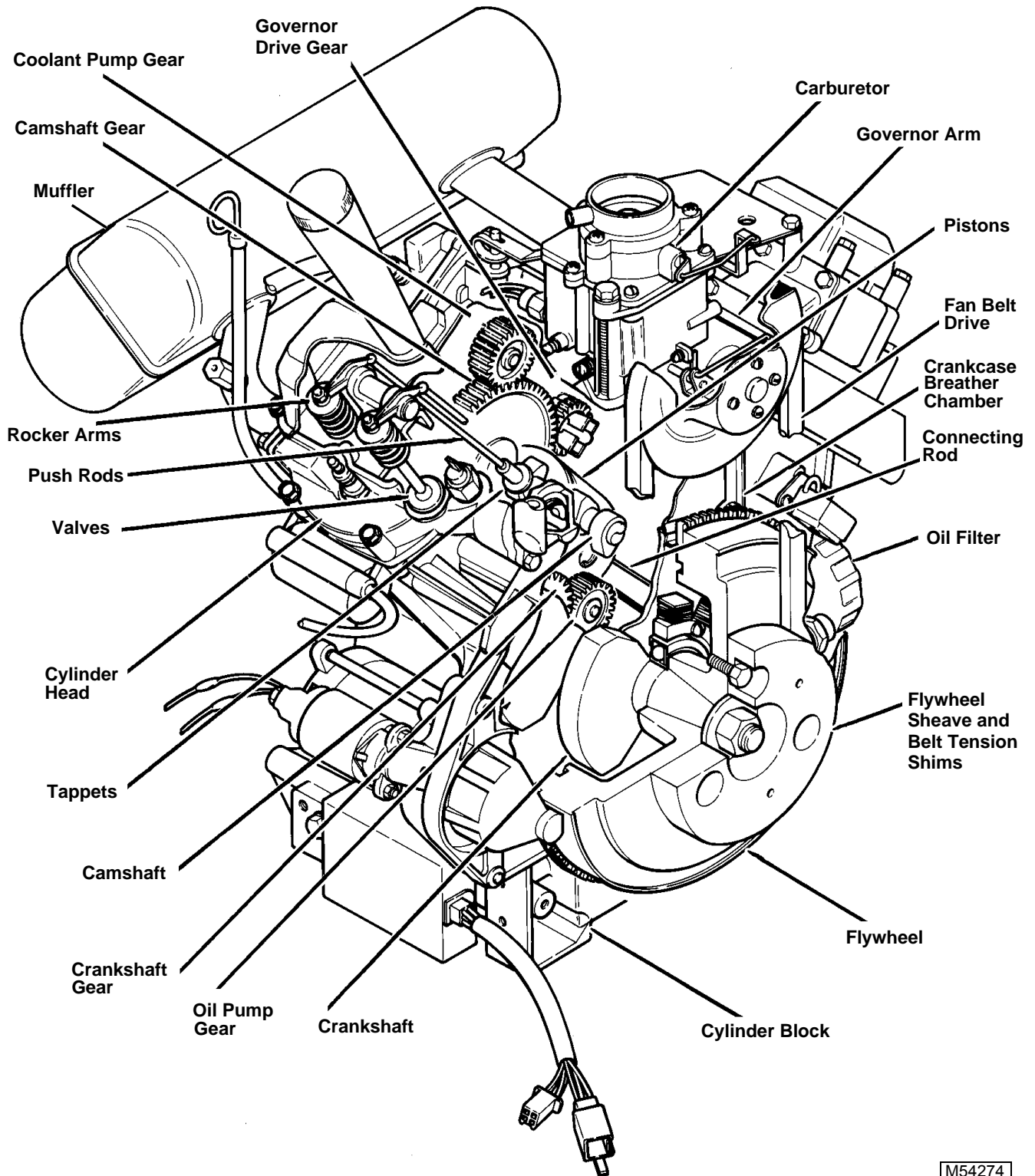

M54274

Cutaway—FD620D

THEORY OF OPERATION

COOLING SYSTEM OPERATION

Function:

The coolant pump circulates coolant through the cooling system, drawing hot coolant from the engine block, and circulating it through the radiator for cooling.

System Operation:

The impeller-type coolant pump draws coolant from the bottom of the radiator when the thermostat is open or from the bypass when the thermostat is closed. Coolant from the water pump flows to the water jackets in block, up through cylinder heads, intake manifold, past the coolant temperature sensor and thermostat.

When the engine temperature is below approximately 66°C (150°F), the thermostat is closed and coolant is directed back to the water pump through bypass hose to be recirculated. This allows the engine to warm up to operating temperature quickly.

When the engine temperature is approximately 66°C (150°F), the thermostat begins to open and is fully open at 80°C (176°F). Coolant from the water jackets and cylinder heads now flow through the thermostat to the radiator, which is cooled by the radiator fan. The fan is driven by a belt off the crankshaft pulley.

The radiator cap maintains a constant pressure of 90 kPa (13 psi) inside the radiator which actually raises the boiling point of the coolant. The radiator cap contains a pressure valve and a vacuum valve. When the coolant is hot and pressure is above 90 kPa (13 psi), the pressure valve opens allowing some coolant to flow to the recovery tank. After the engine is stopped, the coolant cools and the pressure inside the radiator decreases. The pressure difference between the radiator and recovery tank forces the vacuum valve open and some coolant from the recovery tank flows back to the radiator.

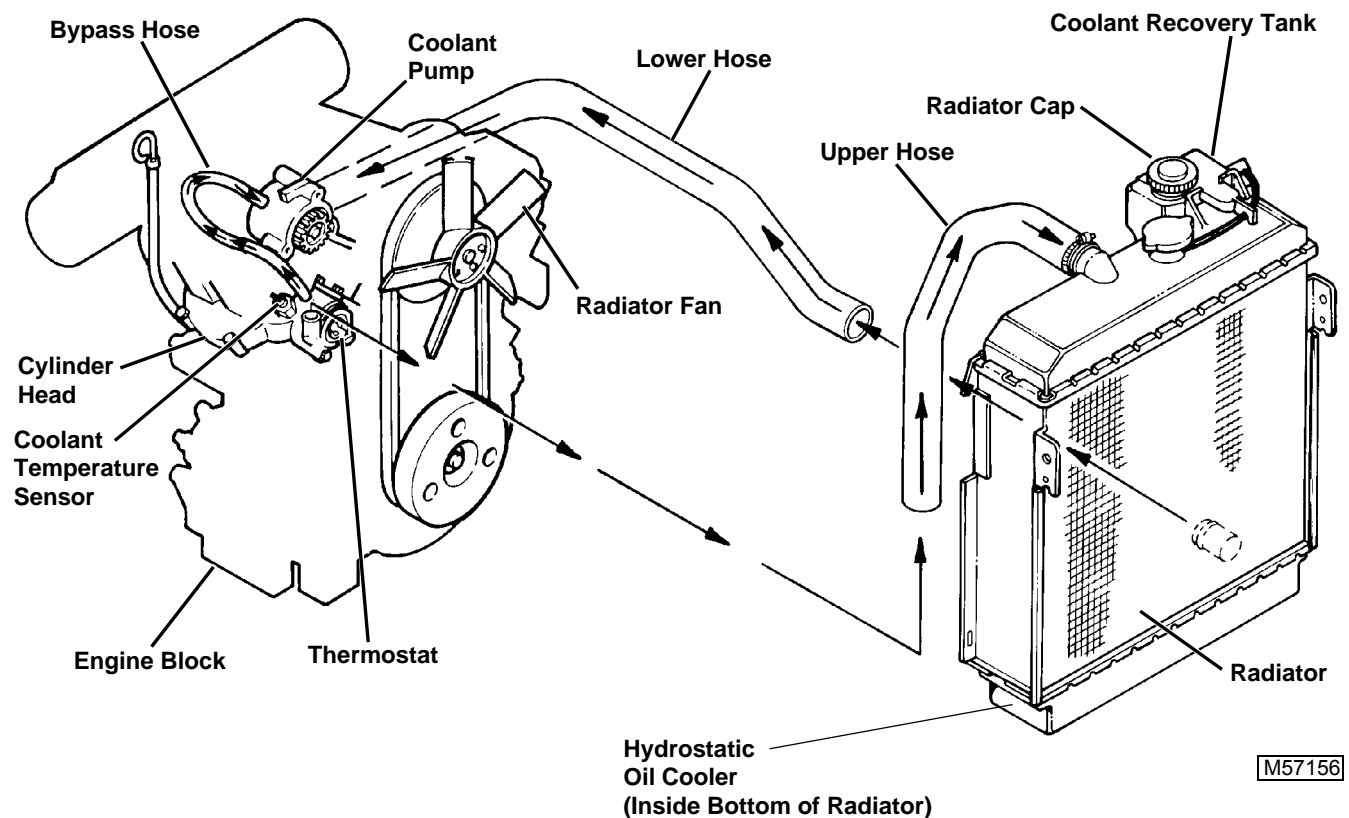

M57156

CARBURETED ENGINE FUEL AND AIR SYSTEM OPERATION—425

Function:

The fuel system supplies pressurized fuel to the carburetor for combustion. The air intake system filters air needed for combustion.



System Operation:

An electric fuel pump mounted inside the fuel tank provides pressurized fuel to the carburetor. The fuel pump uses the fuel for lubrication and cooling. The fuel pump draws fuel through the fuel pump filter. Low pressure fuel from the fuel pump flows through the fuel shut-off valve and in-line fuel filter to the carburetor. Fuel pressure is maintained at the carburetor inlet needle until the float allows more fuel in the bowl. The fuel tank relief/check valve prevents gas fumes from escaping into the air for emission control. When the fuel tank starts to create a vacuum, the check valve opens and allows air into the tank, but closes for air trying to escape from the tank. The tank will pressurize up to 3 kPa (0.4 psi) before the relief valve opens and allows the air pressure out. The fuel tank cap is NOT vented (carburetor vent solenoid only).

IMPORTANT: Model (S.N. —033626) use a carburetor vent solenoid. Model (S.N. 033627—) use a fuel shut-off solenoid. System operation remains the same expect for the following differences. Lower, upper and inlet vent hoses are removed. Air restriction indicator is removed. Fuel shut-off solenoid shuts off the main jet not atmospheric pressure (vacuum), which eliminates the need for vent hoses. Fuel cap is vented instead of vent hoses with fuel tank relief/check valve.

The carburetor vent solenoid connects both sides of the carburetor venturi through lower and upper vent hoses when the solenoid is de-energized. In this condition, no vacuum is present in the carburetor to draw fuel out of the main nozzle, so the fuel flow is stopped very quickly. The ignition delay module is used with the carburetor vent/fuel shut-off solenoid to prevent backfire. The ignition delay module allows the spark plugs to fire for one additional second after the key switch is turned off to burn any remaining fuel in the cylinder. When the key switch is turned off, the carburetor vent/fuel shut-off solenoid is de-energized. When the key switch is turned on, the carburetor vent solenoid closes the venturi vent tubes, so a vacuum can be created for fuel flow.

Air enters the air filter through the side panel screen and air filter inlet hose. The primary and secondary elements filter the air before entering the carburetor. The breather hose vents crankcase fumes into the carburetor for burning to decrease emissions. An air restriction indicator alerts the operator when the filters need servicing. The air restriction indicator senses the amount of vacuum in the intake system.

NOTE: Air restriction indicators are removed for model (S.N. 033627—).

A small amount of air restriction is always present due to some restriction of air movement through the filter elements. The vacuum increases as the filter elements become plugged. The indicator moves to the highest vacuum rating and holds that position until the operator resets it. An air intake leak will prevent the air restriction from operating properly.

CARBURETED ENGINE FUEL AND AIR SYSTEM COMPONENTS AND OPERATION—425

Important: Model S.N. (033627—) have fuel shut-off solenoid instead of carburetor vent solenoid and vent hoses. Air restriction indicator and fuel tank relief/check valve has been removed. Fuel tank cap is vented.

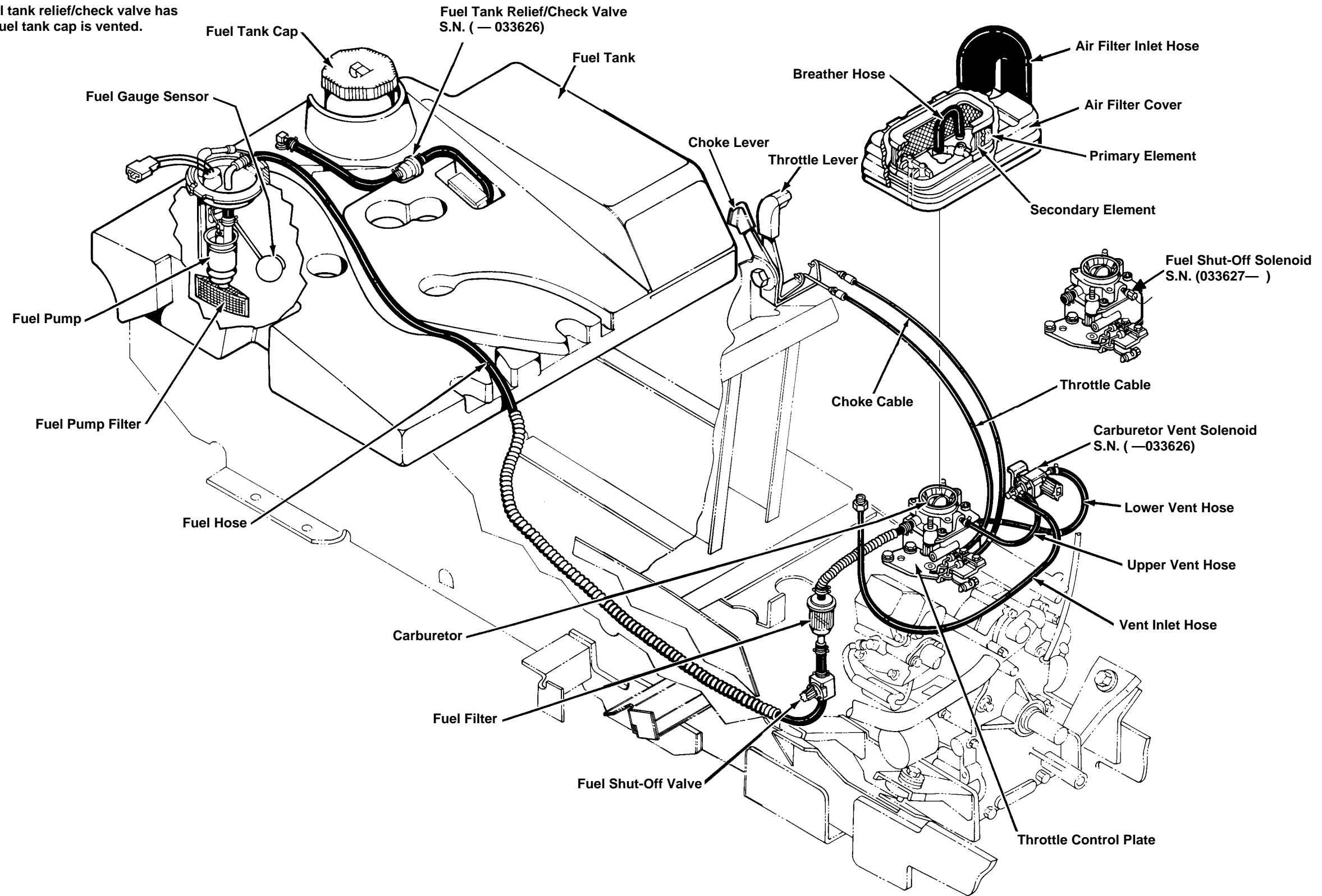

M46319

CARBURETED ENGINE FUEL AND AIR SYSTEM COMPONENTS AND OPERATION—425

Important: Model S.N. (033627—) have fuel shut-off solenoid instead of carburetor vent solenoid and vent hoses. Air restriction indicator and fuel tank relief/check valve has been removed. Fuel tank cap is vented.

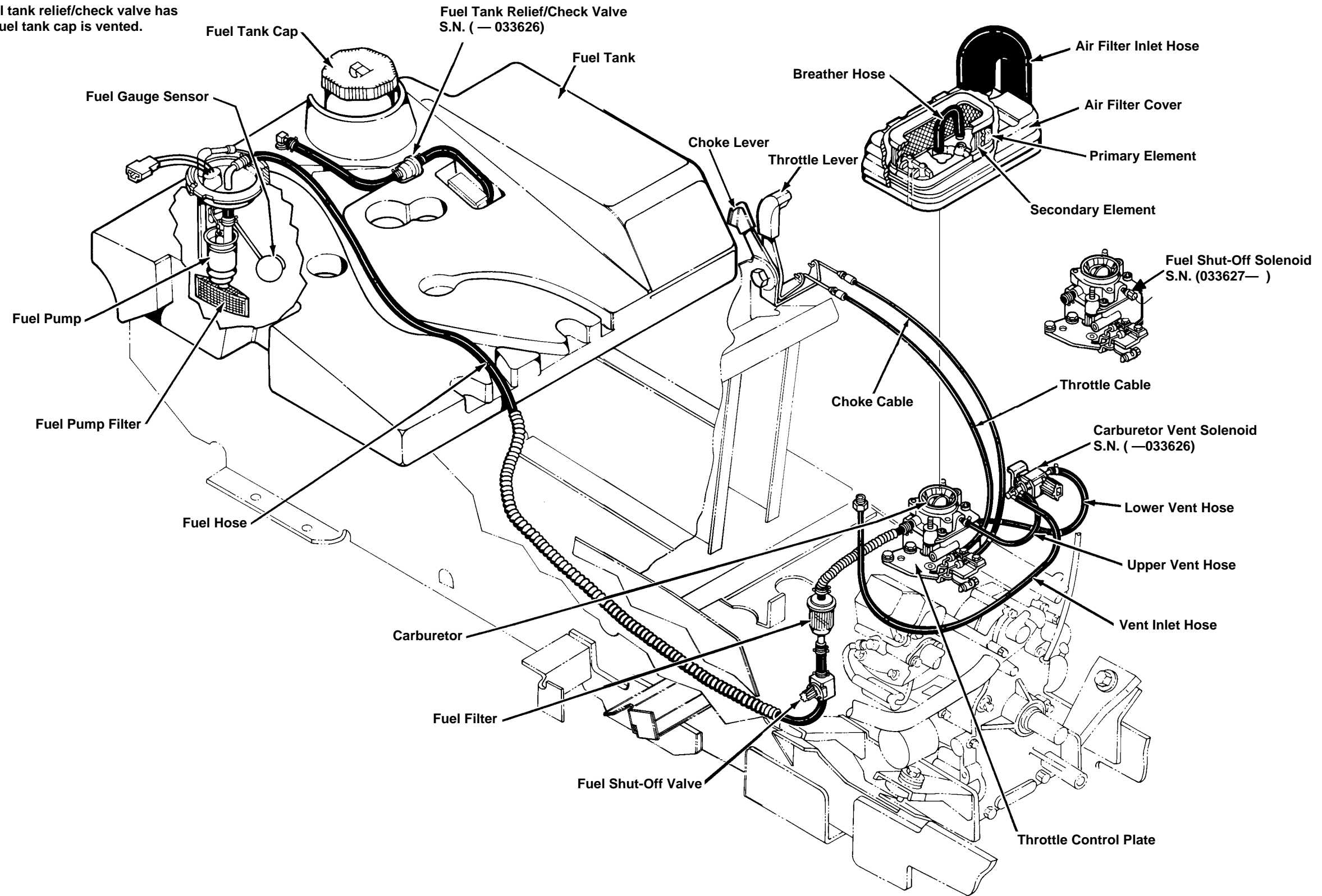

M46319

CARBURETED ENGINE FUEL AND AIR SYSTEM COMPONENTS AND OPERATION—425

Important: Model S.N. (033627—) have fuel shut-off solenoid instead of carburetor vent solenoid and vent hoses. Air restriction indicator and fuel tank relief/check valve has been removed. Fuel tank cap is vented.

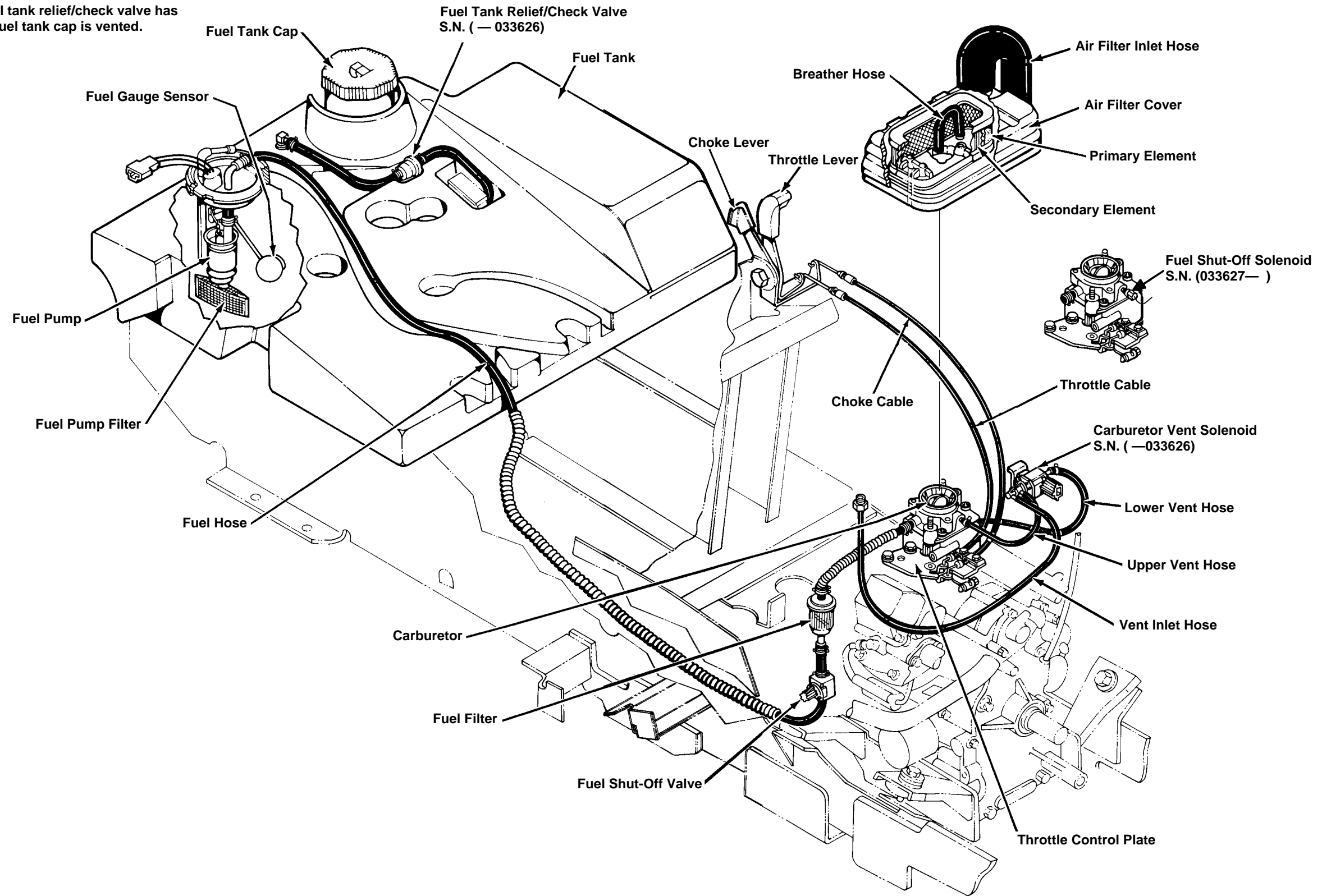

M46319

FUEL INJECTION AND AIR SYSTEM COMPONENTS AND OPERATION—445

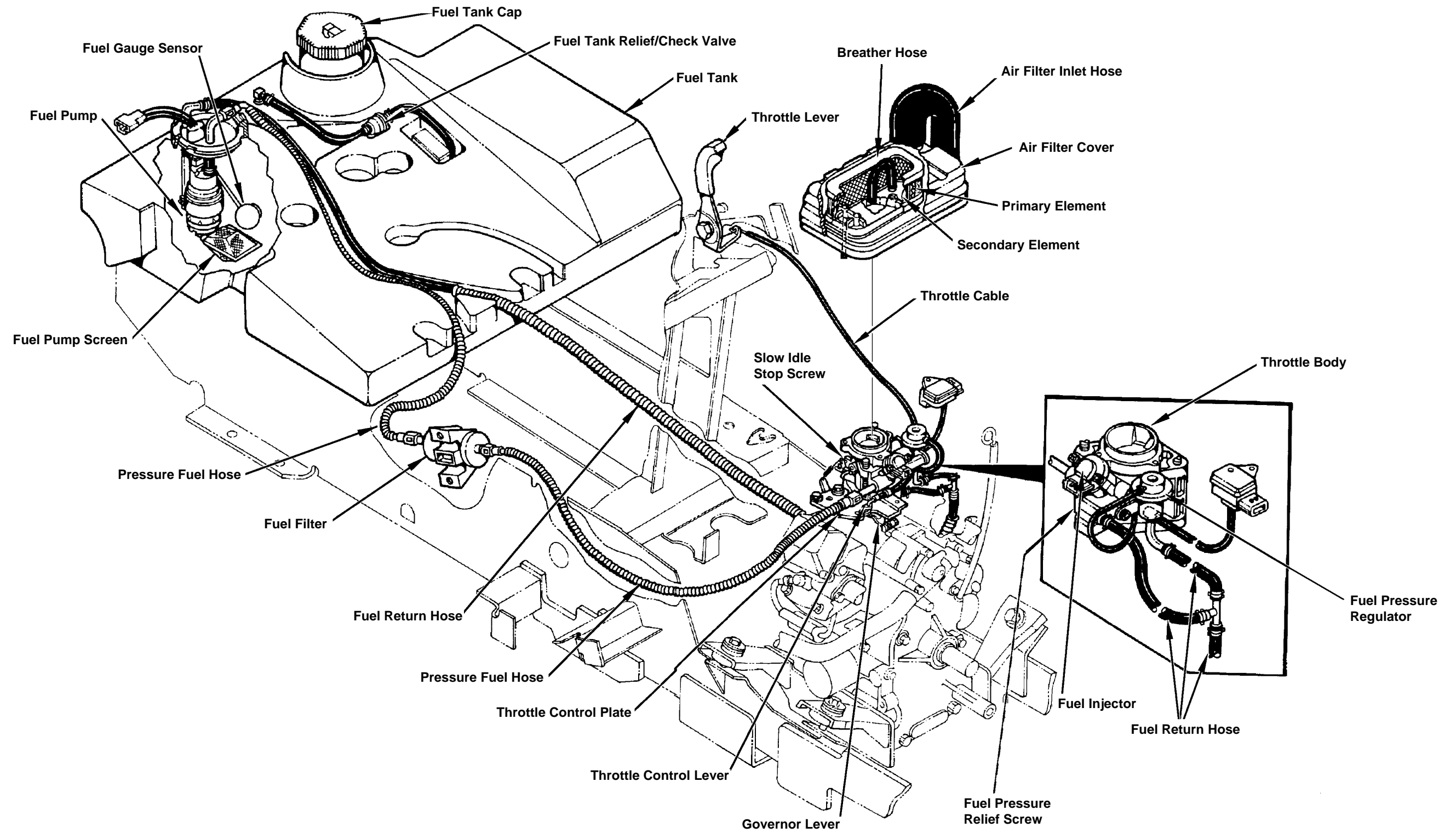

M55612

FUEL INJECTION AND AIR SYSTEM COMPONENTS AND OPERATION—445

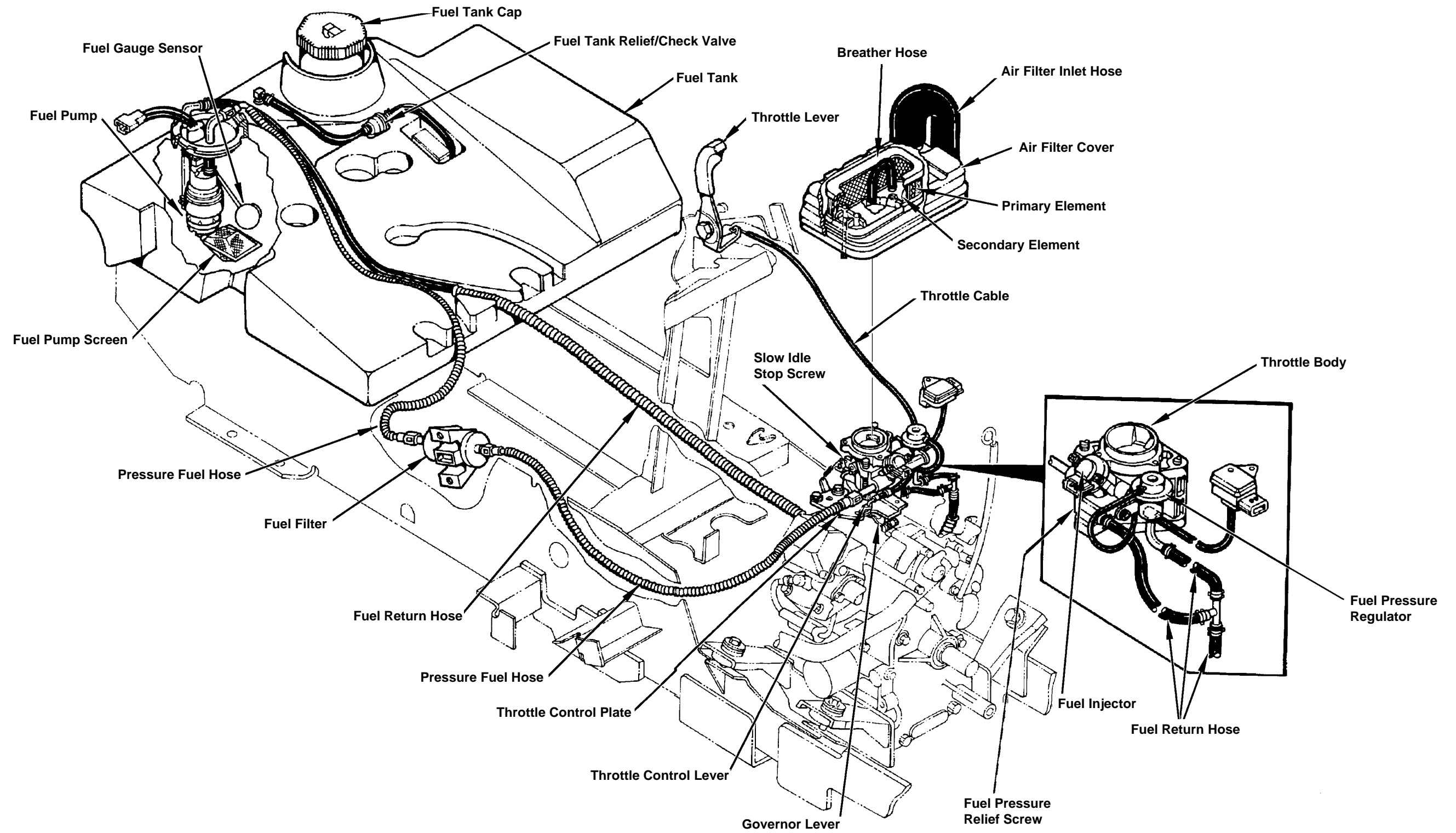

M55612

FUEL INJECTION AND AIR SYSTEM COMPONENTS AND OPERATION—445

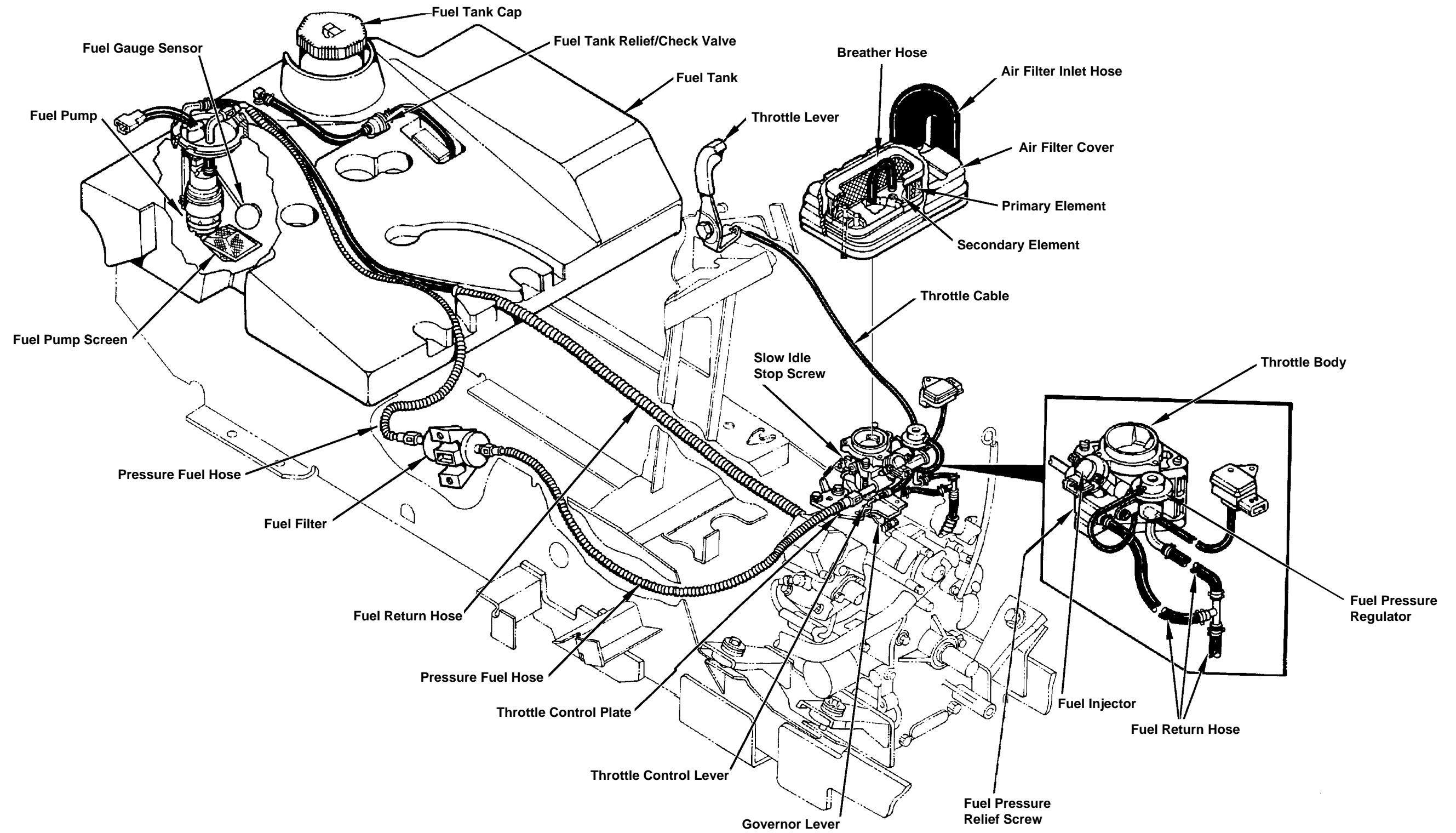

M55612

FUEL INJECTION AIR SYSTEM COMPONENTS AND OPERATION— 445

Function:

The fuel injection system supplies pressurized fuel to the fuel injector for combustion. The air intake system filters air needed for combustion.

System Operation:

An electric fuel pump mounted inside the fuel tank provides pressurized fuel to the fuel injector. The fuel pump uses the fuel for lubrication and cooling. The fuel pump and fuel injector are controlled by the fuel injection module computer. The computer monitors engine operating and environmental conditions to calculate the amount of fuel to inject. The fuel pump draws fuel through the fuel pump screen. High pressure fuel from the fuel pump flows through the in-line fuel filter to the fuel injector and fuel pressure regulator. The fuel injector is a solenoid operated type valve with single point injection. Fuel is injected into the throttle body when the solenoid is energized by the computer. Fuel pressure is controlled by the fuel pressure regulator. The regulator is an overflow type regulator that maintains fuel pressure at the fuel injector at a constant 175 kPa (25 psi). Excess fuel flows through the regulator valve and fuel return hose to the fuel tank. The fuel tank relief/check valve prevents gas fumes from escaping into the air for emission control. When the fuel tank starts to create a vacuum, the check valve opens and allows air into the tank, but closes for air trying to escape from the tank. The tank will pressurize up to 3 kPa (0.4 psi) before the relief valve opens and allows the air pressure out. The fuel tank cap is NOT vented.

The throttle control lever, which is connected to the throttle lever and the governor lever, controls engine rpm. The governor lever is connected to the throttle valve inside the throttle body. Slow idle is adjusted by turning the slow idle stop screw and fast idle is adjusted by moving the throttle control plate.

Air enters the air filter through the side panel screen and air filter inlet hose. The primary and secondary elements filter the air before entering the throttle body. The breather hose vents crankcase fumes into the throttle body for burning to decrease emissions. An air restriction indicator alerts the operator when the filters need servicing. The air restriction indicator senses the amount of vacuum in the intake system. A small amount is always present due to some restriction of air movement through the filter elements. The vacuum increases as the filter elements become plugged. The indicator moves to the highest vacuum rating and holds that position until the operator resets it. An air intake leak will prevent the air restriction indicator from operating properly.



FUEL INJECTOR OPERATION—445

Function:

Injects fuel into the throttle body at the correct time and duration.

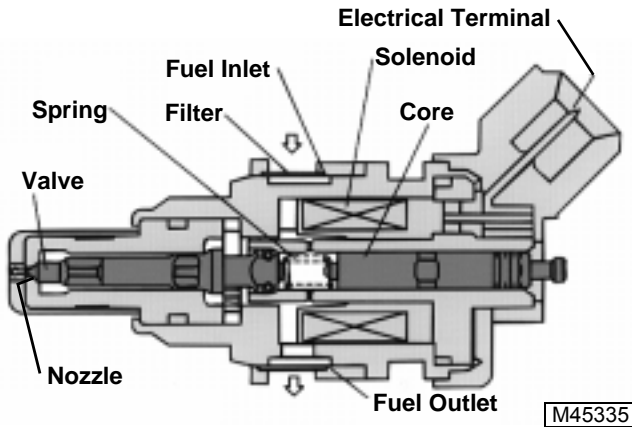

System Operation:

The fuel injector is a solenoid operated type valve with single point injection. Fuel is injected into the throttle body when the solenoid is energized by the computer. The amount of fuel injected depends on the length of time the injector valve is open and on fuel pressure.

High pressure fuel from the fuel pump flows through filter to the inlet passage. High pressure fuel also flows out the outlet passage to the pressure regulator. The pressure regulator maintains the correct fuel pressure needed for injection. When the solenoid is energized, the solenoid core pulls the valve open against spring tension. High pressure fuel is injected in the throttle body through the nozzle. After a precise amount of fuel is injected, the computer de-energizes the solenoid. Spring tension closes valve quickly to prevent additional leakage.

FUEL PRESSURE REGULATOR OPERATION—445

Function:

Maintains a constant differential in pressure between fuel pressure at the injector and air pressure in the throttle body. Therefore, the amount of fuel injected is determined by the opening time of the injector.

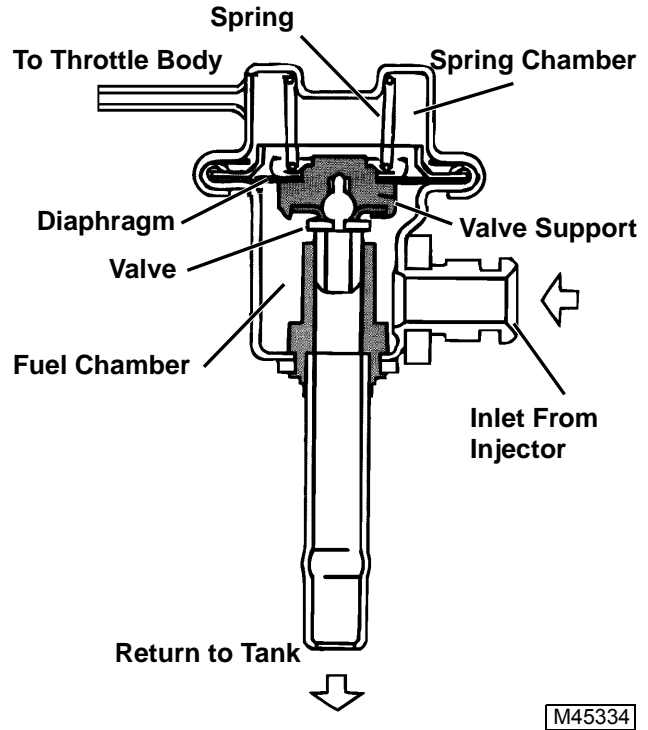

System Operation:

The pressure regulator is an overflow type regulator. The spring chamber is connected to the throttle body to insure that they are operating at the same air pressure. High pressure fuel from the injector flows to the pressure regulator inlet and fills the fuel chamber. A hose from the vacuum inlet is connected to the intake manifold. This allows the air pressure in the spring chamber and intake manifold to be equal.

When intake manifold vacuum increases, the spring chamber vacuum also increases and overcomes spring tension allowing the diaphragm to move upward. With the valve connected to the diaphragm, the valve moves upward and allows more fuel to flow out the outlet and return to the fuel tank. This lowers the fuel pressure. As intake manifold vacuum decreases, the spring chamber vacuum decreases and the spring returns the diaphragm to the original position. The valve restricts fuel flow to return and fuel pressure increases.

GOVERNOR OPERATION

IMPORTANT: Do not remove flyweight assembly or shaft unless damaged. Removal damages the assembly.

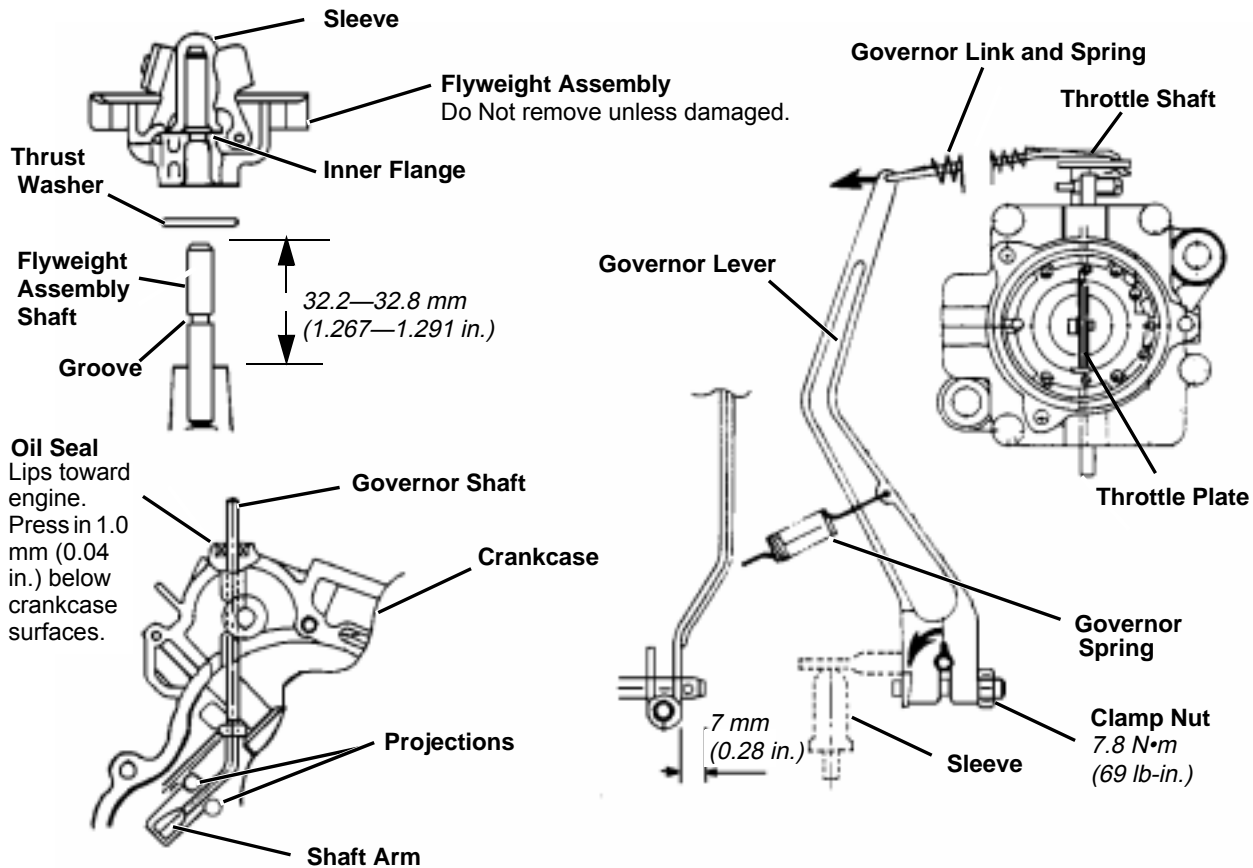

M57332a

System Operation:

The governor controls engine speed. Governed engine speed is a balance between governor spring tension, set by the throttle control, and actual engine speed, countered by centrifugal force of the governor flyweights. As tension is applied to governor spring, governor linkage opens carburetor throttle shaft and plate, increasing engine rpm. As engine speed increases, flyweight assembly (driven by the crankshaft gear) pushes on governor arm, rotating governor shaft and lever, moving throttle shaft, closing throttle plate slightly and reducing rpm to governed operating speed. If a heavy load is encountered, engine speed drops, as does the governor assembly speed. Flyweights retract and allow shaft arm to move governor shaft and lever in opposite direction to open throttle plate and allow more air into venturi to draw in more fuel until engine peak operating speed is recovered. Springs provide a smooth yet responsive transitional control.

IMPORTANT: Flyweight assembly shaft is pressed into crankcase cover and is not serviceable. Therefore, if it is damaged or pulled loose, the crankcase cover **MUST BE** replaced.

LUBRICATION SYSTEM OPERATION

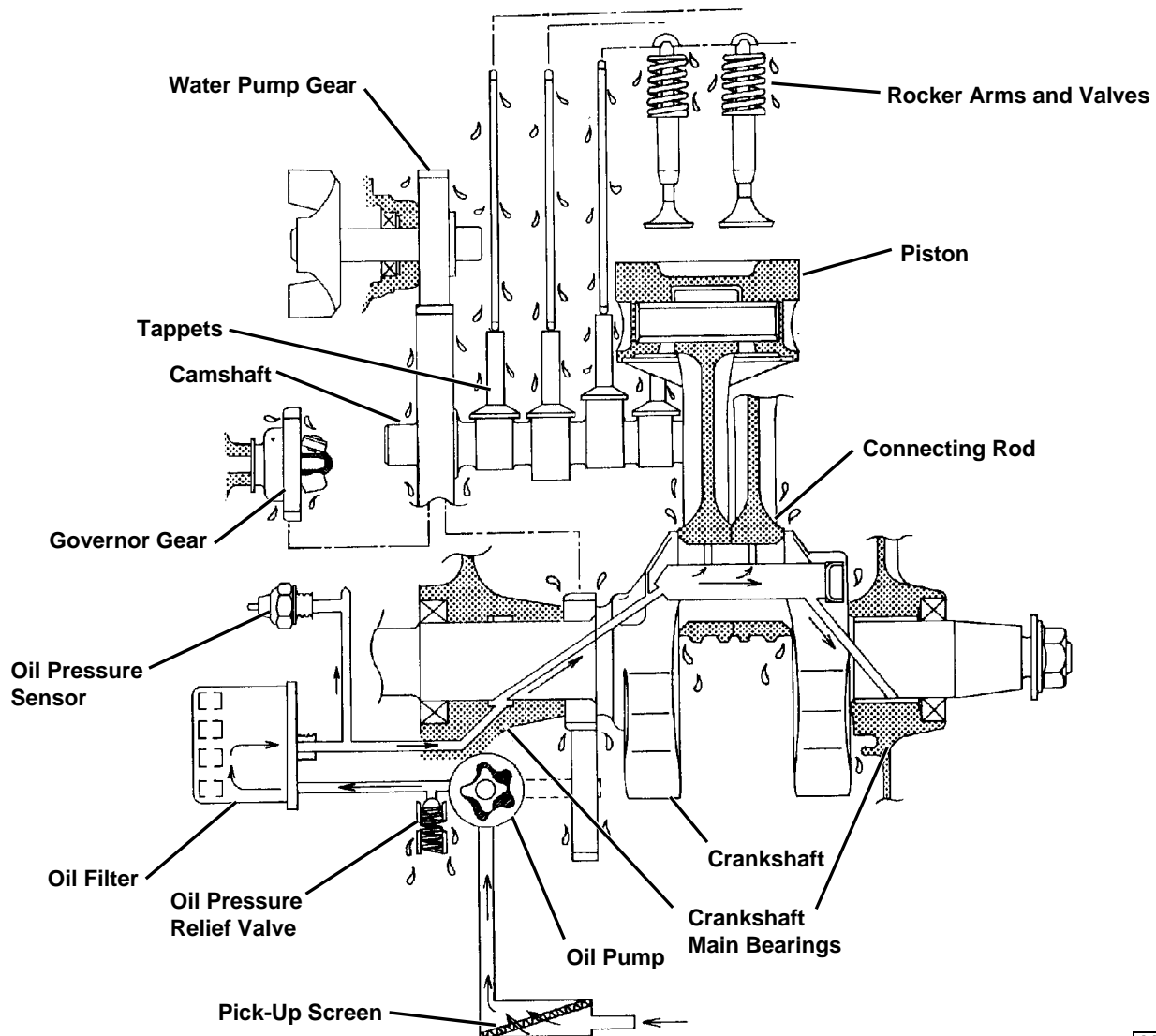

M57349

System Operation

A positive displacement gerotor pump is used to pressurize the lubrication system. The lubrication system is protected by an oil pressure relief valve, low oil pressure switch, and an oil filter with bypass.

The oil pump draws oil from the sump through screen. Pressure oil from the pump flows to the oil pressure relief valve. If oil pressure exceeds 296 kPa (43 psi), the relief valve opens allowing oil to return to sump. Relief valve is not adjustable.

Pressure oil from the relief valve flows to the oil filter. The filter contains a bypass valve which opens if the element becomes plugged to insure engine lubrication.

An oil pressure switch mounted above the oil filter turns on a warning light if oil pressure is below 28 kPa (4 psi). Filtered pressure oil flows through a passage in the oil sump to the crankshaft main bearing (PTO side).

Drilled passages in the crankshaft distribute oil from the main bearing to the connecting rod journals and crankshaft main bearing (flywheel side). A drilled passage in the connecting rods allows oil from the connecting rod journal to lubricate the piston and cylinder walls.

THROTTLE BODY OPERATION—445

Function:

Injects and atomizes the fuel into the intake air for the proper combustion.

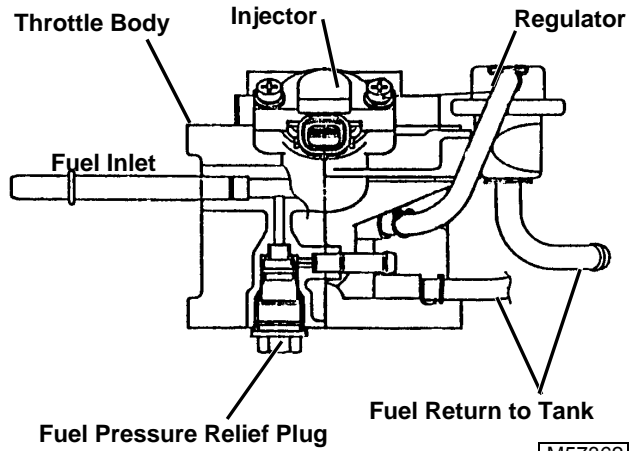

System Operation:

An electric fuel pump, controlled by the computer, supplies fuel to the inlet of the throttle body to the injector. The fuel pressure regulator holds the fuel under pressure in the injector. The computer receives signals from the throttle sensor and other sensors then controls the time the injector is open. The injector injects the atomized fuel into the throat of the throttle body.

Excess fuel not used by the injector flows through the pressure regulator back to the fuel tank.

The FD620 has an extra passage in the throttle body that allows for a means to relieve the fuel pressure in the fuel lines before any work is done on the system.



TROUBLESHOOTING—425 CARBURETED ENGINES

NOTE: See Electrical Section for fuel injection chart.



 Problem or Symptom Check or Solution	Engine cranks but will not start.	Loss of power.	Engine runs erratically.	Engine misses at high rpm.	Engine misses at low rpm.	Excessive fuel consumption.	Excessive oil consumption.	Engine backfires.	Engine knocks.	Coolant leakage.	Engine overheats.
Worn or burned valves or improper clearance.											
Worn valve stem(s) or valve guide(s).											
Warped cylinder head.											
Broken valve spring.											
Defective head gasket.											
Low oil level.											
Too much oil in crankcase.											
Carburetor out of adjustment.											
Air/fuel passages clogged.											
Carbon deposits in exhaust pipe/muffler.											
Carbon deposits in combustion chamber.											
Lack of coolant.											
Governor linkage out of adjustment.											
Faulty governor spring.											
Governor gear assembly binding or broken.											
Air being drawn through carburetor or intake manifold flanges.											
Incorrect timing gear alignment.											

TROUBLESHOOTING—425 CARBURETED ENGINES (continued)

Problem or Symptom ↙ ↘ Check or Solution	Engine cranks but will not start.	Loss of power.	Engine runs erratically.	Engine misses at high rpm.	Engine misses at low rpm.	Excessive fuel consumption.	Excessive oil consumption.	Engine backfires.	Engine knocks.	Coolant leakage.	Engine overheats.
Plugged oil ring groove.											
Check spark—see Electrical Section.											
Incorrect oil viscosity.											
Carburetor flange loose or leaking at gasket.											
Carburetor body and throttle shaft worn.											
Intake valve burned or sticking.											
Excessive engine load.											
Fan belt slippage.											
Defective radiator hose or clamp.											
Broken or missing fan shroud.											
Defective radiator.											
Cracked or porous casting.											
Loose stud bolts and cap screw.											
Engine overheating.											
Damaged water pump seals.											
Improperly installed gasket.											
Improper or defective radiator cap.											



TROUBLESHOOTING—425 CARBURETED ENGINES (continued)



Problem or Symptom Check or Solution	Engine cranks but will not start.	Loss of power.	Engine runs erratically.	Engine misses at high rpm.	Engine misses at low rpm.	Excessive fuel consumption.	Excessive oil consumption.	Engine backfires.	Engine knocks.	Engine rpm low or engine stalls.
Battery weak or discharged.	●									●
Drain-back in breather chamber plugged.							●			
Oil leakage along governor shaft.			●							
Defective oil seal.			●							
Weak or faulty spark plug.	●	●	●	●	●	●				
Faulty high tension leads.	●	●	●	●	●	●				
Faulty ignition module.	●	●	●	●	●	●		●		
Faulty ignition coil.	●	●	●	●	●	●				
Faulty pulser coil.	●	●	●	●	●	●		●		
Contaminated fuel or faulty fuel supply system.	●	●	●						●	
Fuel shut-off solenoid not allowing fuel into main jet.	●									
Defective fuel pump.	●	●	●	●						
Air being drawn in through a hole in the fuel line(s).	●	●	●					●		

TROUBLESHOOTING—425 CARBURETED ENGINES (continued)

Problem or Symptom Check or Solution	Engine cranks but will not start.	Loss of power.	Engine runs erratically.	Engine misses at high rpm.	Engine misses at low rpm.	Excessive fuel consumption.	Excessive oil consumption.	Engine backfires.	Engine knocks.	Coolant leakage.
Fuel shut-off valve closed (In-line valve).	●									
Clogged fuel line or filter.	●	●	●	●						
Fuel tank vent line clogged.	●	●	●	●						
Vapor lock.		●	●							
Improper use of choke.	●					●				
Air filter restricted.	●	●				●				
Defective breather valve.		●					●			
Float level too high.	●					●				
Poor compression. Worn piston/piston rings stuck or not seated. Worn cylinder bore.	●	●				●	●			
Cylinder head loose.	●	●				●		●		●



TROUBLESHOOTING—425 CARBURETED ENGINES



<div style="display: flex; justify-content: space-between;"> <div style="text-align: right;"> Check or Solution </div> <div style="text-align: left;"> Problem or Symptom </div> </div>	Engine is sluggish.	Black smoky Exhaust.	Runs worse when warm.	Spark plug fouled black.	Runs better without air cleaner.	Engine will not start, plug wet.	Spark plug burned white.	Engine speed unstable (surging).	Loss of power.	Engine overheats.	Engine is hard to start when cold.
Mixture too rich.											
Mixture too lean.											
Check and clean air cleaner.											
Clean under engine shrouding.											
Adjust Idle mixture and check engine performance.											
Choke is not completely open Adjust.											
Inlet needle and seat leaking.											
Choke is not completely shut Adjust.											
Clean Carburetor.											
Check spark plug gap and spark. See Electrical Section.											
Water pump nylon impeller.											

TROUBLESHOOTING—445 FUEL INJECTED ENGINES

See *Electrical Section* for fuel injection chart.

Problem or Symptom ↙ ↘ Check or Solution	Engine cranks but will not start.	Loss of power.	Engine runs erratically.	Engine misses at high rpm.	Engine misses at low rpm.	Excessive fuel consumption.	Excessive oil consumption.	Engine backfires.	Engine knocks.	Coolant leakage.	Engine overheats.
Worn or burned valves or improper clearance.											
Worn valve stem(s) or valve guide(s).											
Warped cylinder head.											
Broken valve spring.											
Defective head gasket.											
Low oil level.											
Too much oil in crankcase.											
Air/fuel passages clogged.											
Carbon deposits in exhaust pipe/muffler.											
Carbon deposits in combustion chamber.											
Lack of coolant.											
Governor linkage out of adjustment.											
Faulty governor spring.											
Governor gear assembly binding or broken.											
Air being drawn through throttle body or intake manifold flanges.											
Incorrect timing gear alignment.											





Suggest:

If the above button click is invalid.

Please download this document

first, and then click the above link

to download the complete manual.

Thank you so much for reading

TROUBLESHOOTING—445 FUEL INJECTED ENGINES (continued)



Problem or Symptom ↙ ↘ Check or Solution	Engine cranks but will not start.	Loss of power.	Engine runs erratically.	Engine misses at high rpm.	Engine misses at low rpm.	Excessive fuel consumption.	Excessive oil consumption.	Engine backfires.	Engine knocks.	Coolant leakage.	Engine overheats.
Plugged oil ring groove.											
Check spark—See Electrical Section.											
Incorrect oil viscosity.											
Throttle body flange loose or leaking at gasket.											
Throttle body and throttle shaft worn.											
Intake valve burned or sticking.											
Excessive engine load.											
Fan belt slippage.											
Defective radiator hose or clamp.											
Broken or missing fan shroud.											
Defective radiator.											
Cracked or porous casting.											
Loose stud bolts and cap screw.											
Engine overheating.											
Damaged water pump seals.											
Improperly installed gasket.											
Improper or defective radiator cap.											

<https://www.ebooklibonline.com>

Hello dear friend!

Thank you very much for reading.

Enter the link into your browser.

The full manual is available for immediate download.

<https://www.ebooklibonline.com>