

# **355D Lawn and Garden Tractor**

**Serial No. (085001 - )**

## **TECHNICAL MANUAL**

**John Deere  
Worldwide Commercial and  
Consumer Equipment Division**

**TM1771 (May00)**



This technical manual is written for an experienced technician and contains sections that are specifically for this product. It is a part of a total product support program.

The manual is organized so that all the information on a particular system is kept together. The order of grouping is as follows:

- Table of Contents
- General Diagnostic Information
- Specifications
- Electrical Wiring Harness Legend
- Component Location
- System Schematic
- Wiring Harness
- Troubleshooting Chart
- Theory of Operation
- Diagnostics
- Tests & Adjustments
- Repair











*Note: Depending on the particular section or system being covered, not all of the above groups may be used.*

Each section will be identified with a symbol rather than a number. The groups and pages within a section will be consecutively numbered.

We appreciate your input on this manual. To help, there are postage paid post cards included at the back. If you find any errors or want to comment on the layout of the manual please fill out one of the cards and mail it back to us.

All information, illustrations and specifications in this manual are based on the latest information available at the time of publication. The right is reserved to make changes at any time without notice.

COPYRIGHT© 1999  
 Deere and Co.  
 John Deere Worldwide Commercial and  
 Consumer Equipment Division  
 Horicon, WI  
 All rights reserved

<b>Safety</b>	
<b>Specifications and General Information</b>	
<b>Engine (2V-78)</b>	
<b>Electrical</b>	
<b>Electrical - Export Model</b>	
<b>Power Train (Hydrostatic)</b>	
<b>Steering</b>	
<b>Brakes</b>	
<b>Hydraulics</b>	
<b>Attachments</b>	
<b>Miscellaneous</b>	<b>M</b>

**<https://www.ebooklibonline.com>**

Hello dear friend!

Thank you very much for reading.

Enter the link into your browser.

The full manual is available for immediate download.

**<https://www.ebooklibonline.com>**



## **RECOGNIZE SAFETY INFORMATION**



This is the safety-alert symbol. When you see this symbol on your machine or in this manual, be alert to the potential for personal injury.

Follow recommended precautions and safe servicing practices.

### **Understand Signal Words**

A signal word—DANGER, WARNING, or CAUTION—is used with the safety-alert symbol. DANGER identifies the most serious hazards.

DANGER or WARNING safety signs are located near specific hazards. General precautions are listed on CAUTION safety signs. CAUTION also calls attention to safety messages in this manual.

## **REPLACE SAFETY SIGNS**

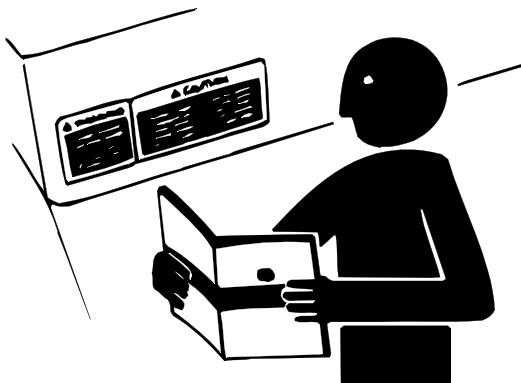

Replace missing or damaged safety signs. See the machine operator's manual for correct safety sign placement.

## **HANDLE FLUIDS SAFELY-AVOID FIRES**

### **Be Prepared For Emergencies**

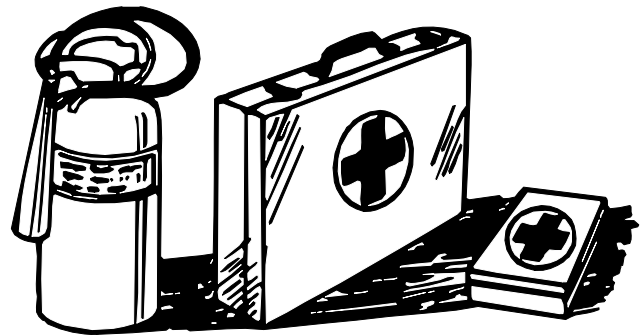

When you work around fuel, do not smoke or work near heaters or other fire hazards.

Store flammable fluids away from fire hazards. Do not incinerate or puncture pressurized containers.

Make sure machine is clean of trash, grease, and debris.

Do not store oily rags; they can ignite and burn spontaneously.

Be prepared if a fire starts.

Keep a first aid kit and fire extinguisher handy.

Keep emergency numbers for doctors, ambulance service, hospital, and fire department near your telephone.

## USE CARE IN HANDLING AND SERVICING BATTERIES

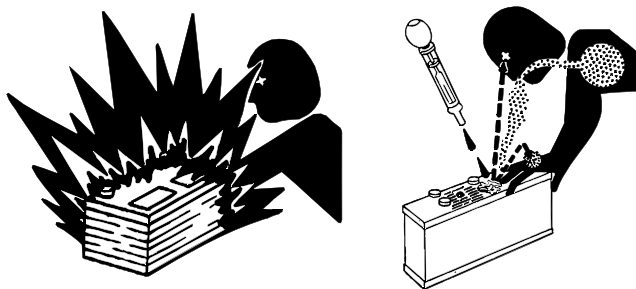

### Prevent Battery Explosions

- Keep sparks, lighted matches, and open flame away from the top of battery. Battery gas can explode.
- Never check battery charge by placing a metal object across the posts. Use a volt-meter or hydrometer.
- Do not charge a frozen battery; it may explode. Warm battery to 16°C (60°F).

### Prevent Acid Burns

- Sulfuric acid in battery electrolyte is poisonous. It is strong enough to burn skin, eat holes in clothing, and cause blindness if splashed into eyes.
- **Avoid acid burns by:**
  1. Filling batteries in a well-ventilated area.
  2. Wearing eye protection and rubber gloves.
  3. Avoiding breathing fumes when electrolyte is added.
  4. Avoiding spilling or dripping electrolyte.
  5. Use proper jump start procedure.
- **If you spill acid on yourself:**
  1. Flush your skin with water.
  2. Apply baking soda or lime to help neutralize the acid.
  3. Flush your eyes with water for 10\_15 minutes.
  4. Get medical attention immediately.
- **If acid is swallowed:**
  1. Drink large amounts of water or milk.
  2. Then drink milk of magnesia, beaten eggs, or vegetable oil.
  3. Get medical attention immediately.

## USE CARE AROUND HIGH-PRESSURE FLUID LINES

### Avoid High-pressure Fluids

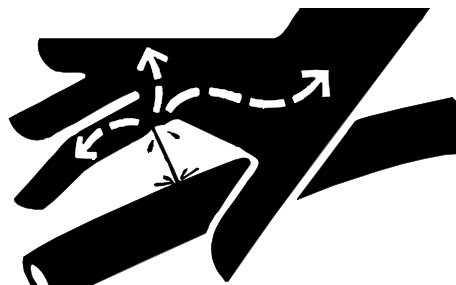

Escaping fluid under pressure can penetrate the skin causing serious injury.

Avoid injury from escaping fluid under pressure by stopping the engine and relieving pressure in the system before disconnecting or connecting hydraulic or other lines. Tighten all connections before applying pressure.

Search for leaks with a piece of cardboard. Protect hands and body from high pressure fluids.

If an accident occurs, see a doctor immediately. Any fluid injected into the skin must be surgically removed within a few hours or gangrene may result. Doctors unfamiliar with this type of injury should reference a knowledgeable medical source. Such information is available from Deere & Company Medical Department in Moline, Illinois, U.S.A.

### Avoid Heating Near Pressurized Fluid Lines



Flammable spray can be generated by heating near pressurized fluid lines, resulting in severe burns to yourself and bystanders. Do not heat by welding, soldering, or using a torch near pressurized fluid lines or other flammable materials. Pressurized lines can be accidentally cut when heat goes beyond the immediate flame area.



## **USE SAFE SERVICE PROCEDURES**

### **Wear Protective Clothing**

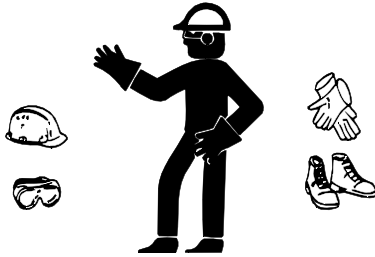

Wear close fitting clothing and safety equipment appropriate to the job.

Prolonged exposure to loud noise can cause impairment or loss of hearing. Wear a suitable hearing protective device such as earmuffs or earplugs to protect against objectionable or uncomfortable loud noises.

Operating equipment safely requires the full attention of the operator. Do not wear radio or music headphones while operating machine.

### **Service Machines Safely**

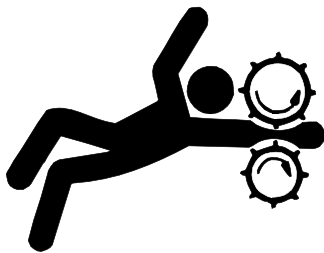

Tie long hair behind your head. Do not wear a necktie, scarf, loose clothing, or necklace when you work near machine tools or moving parts. If these items were to get caught, severe injury could result.

Remove rings and other jewelry to prevent electrical shorts and entanglement in moving parts.

### **Use Proper Tools**

Use tools appropriate to the work. Makeshift tools and procedures can create safety hazards. Use power tools only to loosen threaded parts and fasteners. For loosening and tightening hardware, use the correct size tools. **DO NOT** use U.S. measurement tools on metric fasteners. Avoid bodily injury caused by slipping wrenches. Use only service parts meeting John Deere specifications.

### **Park Machine Safely**

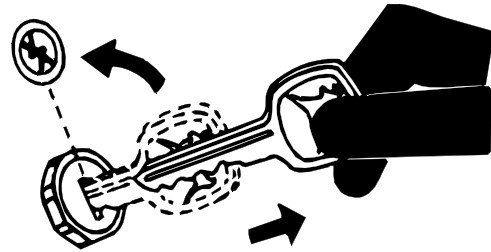

#### **Before working on the machine:**

1. Lower all equipment to the ground.
2. Stop the engine and remove the key.
3. Disconnect the battery ground strap.
4. Hang a "DO NOT OPERATE" tag in operator station.

### **Support Machine Properly And Use Proper Lifting Equipment**

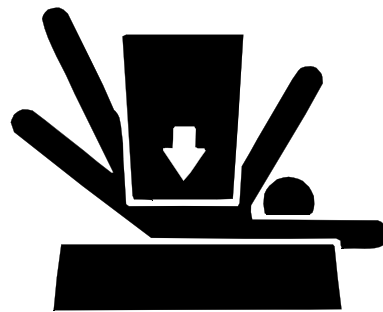

If you must work on a lifted machine or attachment, securely support the machine or attachment.

Do not support the machine on cinder blocks, hollow tiles, or props that may crumble under continuous load. Do not work under a machine that is supported solely by a jack. Follow recommended procedures in this manual.

Lifting heavy components incorrectly can cause severe injury or machine damage. Follow recommended procedure for removal and installation of components in the manual.

### **Work In Clean Area**

#### **Before starting a job:**

1. Clean work area and machine.
2. Make sure you have all necessary tools to do your job.
3. Have the right parts on hand.
4. Read all instructions thoroughly; do not attempt shortcuts.

## Using High Pressure Washers

Directing pressurized water at electronic/electrical components or connectors, bearings, hydraulic seals, fuel injection pumps or other sensitive parts and components may cause product malfunctions. Reduce pressure and spray at a 45 to 90 degree angle.

## Illuminate Work Area Safely

Illuminate your work area adequately but safely. Use a portable safety light for working inside or under the machine. Make sure the bulb is enclosed by a wire cage. The hot filament of an accidentally broken bulb can ignite spilled fuel or oil.

## Work In Ventilated Area

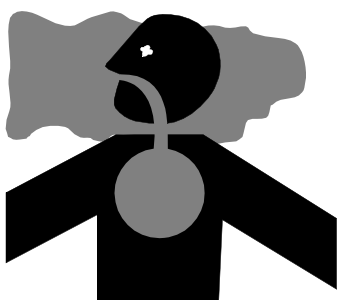

Engine exhaust fumes can cause sickness or death. If it is necessary to run an engine in an enclosed area, remove the exhaust fumes from the area with an exhaust pipe extension.

If you do not have an exhaust pipe extension, open the doors and get outside air into the area.

## WARNING: California Proposition 65

Warning:

Diesel engine exhaust and some of its constituents are known to the State of California to cause cancer, birth defects, and other reproductive harm.

Gasoline engine exhaust from this product contains chemicals known to the State of California to cause cancer, birth defects, or other reproductive harm.

## Remove Paint Before Welding Or Heating

Avoid potentially toxic fumes and dust. Hazardous fumes can be generated when paint is heated by welding, soldering, or using a torch. Do all work outside or in a well ventilated area. Dispose of paint and solvent properly. Remove paint before welding or heating: If you sand or grind paint, avoid breathing the dust. Wear an approved respirator. If you use solvent or paint stripper, remove stripper with soap and water before welding. Remove solvent or paint stripper containers and other flammable material from area. Allow fumes to disperse at least 15 minutes before welding or heating.

## Avoid Harmful Asbestos Dust

Avoid breathing dust that may be generated when handling components containing asbestos fibers. Inhaled asbestos fibers may cause lung cancer.

Components in products that may contain asbestos fibers are brake pads, brake band and lining assemblies, clutch plates, and some gaskets. The asbestos used in these components is usually found in a resin or sealed in some way. Normal handling is not hazardous as long as airborne dust containing asbestos is not generated.

Avoid creating dust. Never use compressed air for cleaning. Avoid brushing or grinding material containing asbestos. When servicing, wear an approved respirator. A special vacuum cleaner is recommended to clean asbestos. If not available, apply a mist of oil or water on the material containing asbestos. Keep bystanders away from the area.



## SERVICE TIRES SAFELY



Explosive separation of a tire and rim parts can cause serious injury or death.

Do not attempt to mount a tire unless you have the proper equipment and experience to perform the job. Always maintain the correct tire pressure. Do not inflate the tires above the recommended pressure. Never weld or heat a wheel and tire assembly. The heat can cause an increase in air pressure resulting in a tire explosion. Welding can structurally weaken or deform the wheel.

When inflating tires, use a clip-on chuck and extension hose long enough to allow you to stand to one side and NOT in front of or over the tire assembly. Use a safety cage if available.

Check wheels for low pressure, cuts, bubbles, damaged rims or missing lug bolts and nuts.



**AVOID INJURY FROM ROTATING BLADES, AUGERS AND PTO SHAFTS**

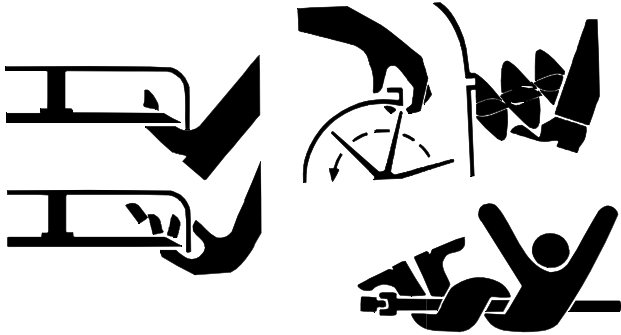

Keep hands and feet away while machine is running. Shut off power to service, lubricate or remove mower blades, augers or PTO shafts.

**SERVICE COOLING SYSTEM SAFELY**



Explosive release of fluids from pressurized cooling system can cause serious burns.

Shut off machine. Only remove filler cap when cool enough to touch with bare hands. Slowly loosen cap to first stop to relieve pressure before removing completely.

**HANDLE CHEMICAL PRODUCTS SAFELY**

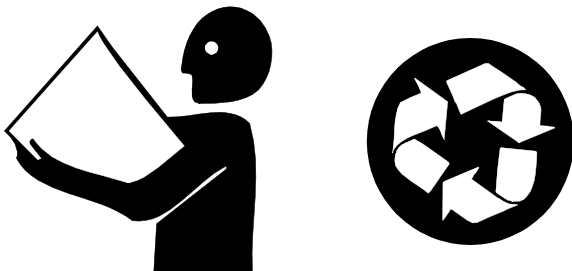

Direct exposure to hazardous chemicals can cause serious injury. Potentially hazardous chemicals used with John Deere equipment include such items as lubricants, coolants, paints, and adhesives.

A Material Safety Data Sheet (MSDS) provides specific details on chemical products: physical and health hazards, safety procedures, and emergency response techniques. Check the MSDS before you start any job using a hazardous chemical. That way you will know exactly what the risks are and how to do the job safely. Then follow procedures and recommended equipment.

**Dispose of Waste Properly**

Improperly disposing of waste can threaten the environment and ecology. Potentially harmful waste used with John Deere equipment include such items as oil, fuel, coolant, brake fluid, filters, and batteries. Use leakproof containers when draining fluids. Do not use food or beverage containers that may mislead someone into drinking from them. Do not pour waste onto the ground, down a drain, or into any water source. Inquire on the proper way to recycle or dispose of waste from your local environmental or recycling center, or from your John Deere dealer.

**LIVE WITH SAFETY**



Before returning machine to customer, make sure machine is functioning properly, especially the safety systems. Install all guards and shields.

# CONTENTS

	Page
<b>VEHICLE SPECIFICATIONS</b> .....	<b>3</b>
ENGINE .....	3
FUEL SYSTEM .....	4
ELECTRICAL .....	4
PTO DRIVE .....	5
POWER TRAIN .....	5
STEERING .....	5
BRAKES .....	5
HYDRAULICS .....	5
IMPLEMENT LIFT .....	6
MOWER ATTACHMENTS .....	6
WEIGHTS AND DIMENSIONS .....	6
WHEELS AND TIRES .....	6
METRIC FASTENER TORQUE VALUES .....	7
INCH FASTENER TORQUE VALUES .....	8
O-RING SEAL SERVICE RECOMMENDATIONS .....	9
FACE SEAL FITTINGS WITH INCH STUD ENDS TORQUE .....	9
FACE SEAL FITTINGS WITH METRIC STUD ENDS TORQUE .....	10
O-RING FACE SEAL FITTINGS .....	11
O-RING BOSS FITTINGS .....	11
<b>GASOLINE SPECIFICATIONS</b> .....	<b>12</b>
<b>LUBRICANTS</b> .....	<b>14</b>
BREAK-IN ENGINE OIL .....	15
OIL FILTERS .....	15
HYDROSTATIC TRANSMISSION AND HYDRAULIC OIL .....	16
ANTI-CORROSION GREASE SPECIFICATIONS .....	16
ALTERNATIVE LUBRICANTS .....	17
SYNTHETIC LUBRICANTS .....	17
LUBRICANT STORAGE .....	17
MIXING OF LUBRICANTS .....	17
CHASSIS GREASE .....	17
<b>COOLANT SPECIFICATIONS</b> .....	<b>18</b>
GASOLINE ENGINE COOLANT .....	18
GASOLINE ENGINE COOLANT DRAIN INTERVAL .....	18
<b>SERIAL NUMBER LOCATION</b> .....	<b>19</b>
MACHINE IDENTIFICATION NUMBER .....	19
ENGINE SERIAL NUMBER .....	19
CARBURETOR SERIAL NUMBER .....	19
HYDROSTATIC TRANSMISSION SERIAL NUMBER .....	20





**VEHICLE SPECIFICATIONS**

**ENGINE**

Make .....	Yanmar
Type .....	Diesel
Model .....	2V78
Horsepower (SAEJ1940).....	13.4 kW (18 hp)
Cylinders .....	2, V-twin
Displacement .....	749 cc(46 cu in.)
Stroke/Cycle .....	4 Cycle
Bore .....	78 mm (3.07 in.)
Stroke .....	78.4 mm (3.09 in.)
Compression Ratio .....	22:1
Slow Idle .....	1000 ± 50 rpm
Valves .....	Overhead
Lubrication.....	Pressurized
Oil Filter.....	Full Flow Filter
Cooling System.....	Liquid Cooled
Coolant Capacity.....	3.6 L (3.8 U.S. qt)
Air Cleaner .....	Paper, Dry-type with Primary and Secondary Elements
Muffler .....	Horizontal discharge below frame
Engine Oil Capacity	
With Filter .....	2.27 L (2.4 U.S. qt)
Without Filter .....	2.08 L (2.2 U.S. qt)



**FUEL SYSTEM**

Fuel Tank Location .....	Rear
Fuel Tank Capacity (Total).....	14.4 L (3.8 U.S. gal)
Fuel (min. octane) .....	Diesel, No. 1 or No. 2
Fuel Pump Location .....	Left Side Frame Rail - Under Hood
Fuel Pump Type .....	In-line with Electric Shutoff
Fuel Delivery .....	Indirect Injection
Fuel Shut-Off.....	Injection Pump
Fuel Filter .....	Replaceable, In-line
Fuel Gauge .....	Translucent Fuel Tank

**ELECTRICAL**

Ignition . . . . . Electronic  
 Type of Starter . . . . . Solenoid Shift  
 Charging System . . . . . Flywheel Alternator  
 Charging Capacity: . . . . . 20 amp Regulated  
 Battery Type . . . . . BCI Group 51  
 Battery Voltage . . . . . 12 V  
 Battery Cold Cranking amps at -17.8° C (0° F) . . . . . 500 amps  
 Battery Reserve Capacity at 25 amp . . . . . 90 minutes  
 Headlights . . . . . Incandescent, Standard  
 Indicator Lights . . . . . Engine Oil Pressure, Battery Charge  
 . . . . . Coolant Temperature  
 . . . . . Glow Plug  
 Gauges . . . . . Hourmeter  
 Ignition Interlock Switches . . . . . Neutral Start, Operator Presence



**PTO DRIVE**

Type . . . . . V-Belt  
 Clutch Type . . . . . Engine Mounted, Electric

**POWER TRAIN**

Drive Wheels . . . . . Rear  
 Traction Drive . . . . . Hydrostatic, Twin Touch™ Foot Control  
 Transmission . . . . . Hydrostatic, Piston Type  
 Transmission Model . . . . . Kanzaki K70A  
 Transmission Oil Capacity . . . . . 4.3 L (4.5 U.S. qts)  
 Transmission Drive . . . . . Double V-Belt  
 Transmission Filter . . . . . Replaceable Internal Cartridge  
 Fan Blade Size . . . . . 9 in. Diameter  
 Axle Type/Wheel Hubs . . . . . Straight with Separate 5-Bolt Hubs  
 Cruise Control . . . . . Forward Travel, Lever on Dash  
 Travel Speeds at Full rpm  
 Forward . . . . . 0—11.2 km/h (0—7 mph)  
 Reverse . . . . . 0—6.4 km/h (0—4 mph)

**STEERING**

Type:  
 Type . . . . . Power, Hydraulic, Front Wheels  
 Tilt Wheel . . . . . 5 Position

**BRAKES**

Location . . . . . Transmission  
 Type . . . . . Internal Wet Disk, Single Pedal  
 Parking Brake . . . . . Brake Pedal Lock Lever

**HYDRAULICS**

System . . . . . Lift and Steering  
 Lift Control Valve  
     Type . . . . . Mechanical, Spool Valve  
     Location . . . . . Under Tunnel Cover  
 Cutting Unit Lift . . . . . Rear Cylinder  
 Filter . . . . . 10 Micron, Replaceable, In-Line

**IMPLEMENT LIFT**

Lift System . . . . . Hydraulic with Depth Stop  
 Lift Lever Location . . . . . Right-Hand Side of Dash  
 Cutting Heights (Independent of Lifts) . . . . . 12.7—143.3 mm (6.35 mm increments)  
     . . . . . 0.500—4.500 in. (0.250 in. increments)  
 Note: Heights may only be set while lift is in raised position.

**MOWER ATTACHMENTS**

Cutting Unit Drive . . . . . Belt

**WEIGHTS AND DIMENSIONS**

Net Weight (less attachments and fuel) . . . . . 291 kg (642 lbs)  
 Mower Deck Weight  
     38-Inch Mower Deck . . . . . 43 kg (95 lbs)  
     44-Inch Mower Deck . . . . . 49 kg (108 lbs)  
     48-Inch Mower Deck . . . . . 57 kg (125 lbs)  
     54-Inch Mower Deck . . . . . 64 kg (140 lbs)  
 Wheel Base . . . . . 1.22 m (47.9 in.)  
 Tread Width  
     Rear wheels in Narrow Position . . . . . 991 mm (39 in.)  
     Rear wheels in Wide Position . . . . . 1.0 m (41.5 in.)  
 Turning Radius (inside rear wheel) . . . . . 0.64 m (25 in.)  
 Overall Length . . . . . 1.84 m (72.25 in.)  
 Overall Height . . . . . 1.11 m (43.6 in.)  
 Overall Width (without attachments) . . . . . 0.99—1.05 m (39—41.5 in.)  
     With 38-Inch Mower Deck . . . . . 1.33 m (52.60 in.)  
     With 44-Inch Mower Deck . . . . . 1.16 m (45.70 in.)  
     With 48-Inch Mower Deck . . . . . 1.52 m (60 in.)  
     With 54-Inch Mower Deck . . . . . 1.68 m (66 in.)



### WHEELS AND TIRES

Front ..... 16 x 6.50-8.00, 2 or 4 ply, Turf  
Inflation Pressure ..... 69—97 kPa (10—15 psi)  
Rear ..... 23 x 10.50-12.00, Turf  
Inflation Pressure ..... 55—69 kPa (8—10 psi)

#### Optional Tires:

Front ..... 16 x 6.50-8.00, 4PR, Turf  
Inflation Pressure ..... 69—97 kPa (10—15 psi)  
Rear ..... 23 x 10.50-12.00, Bar  
Inflation Pressure ..... 55—69 kPa (8—10 psi)

(Specifications and design subject to change without notice.)



**METRIC FASTENER TORQUE VALUES**

Property Class and Head Markings	4.8		8.8		9.8		10.9		12.9	
Property Class and Nut Markings	5		10		10		10		12	

TS1163

SIZE	Class 4.8				Class 8.8 or 9.8				Class 10.9				Class 12.9			
	Lubricated <sup>a</sup>		Dry <sup>a</sup>		Lubricated <sup>a</sup>		Dry <sup>a</sup>		Lubricated <sup>a</sup>		Dry <sup>a</sup>		Lubricated <sup>a</sup>		Dry <sup>a</sup>	
	N•m	lb-ft	N•m	lb-ft	N•m	lb-ft	N•m	lb-ft	N•m	lb-ft	N•m	lb-ft	N•m	lb-ft	N•m	lb-ft
M6	4.8	3.5	6	4.5	9	6.5	11	8.5	13	9.5	17	12	15	11.5	19	14.5
M8	12	8.5	15	11	22	16	28	20	32	24	40	30	37	28	47	35
M10	23	17	29	21	43	32	55	40	63	47	80	60	75	55	95	70
M12	40	29	50	37	75	55	95	70	110	80	140	105	130	95	165	120
M14	63	47	80	60	120	88	150	110	175	130	225	165	205	150	260	190
M16	100	73	125	92	190	140	240	175	275	200	350	225	320	240	400	300
M18	135	100	175	125	260	195	330	250	375	275	475	350	440	325	560	410
M20	190	140	240	180	375	275	475	350	530	400	675	500	625	460	800	580
M22	260	190	330	250	510	375	650	475	725	540	925	675	850	625	1075	800
M24	330	250	425	310	650	475	825	600	925	675	1150	850	1075	800	1350	1000
M27	490	360	625	450	950	700	1200	875	1350	1000	1700	1250	1600	1150	2000	1500
M30	675	490	850	625	1300	950	1650	1200	1850	1350	2300	1700	2150	1600	2700	2000
M33	900	675	1150	850	1750	1300	2200	1650	2500	1850	3150	2350	2900	2150	3700	2750
M36	1150	850	1450	1075	2250	1650	2850	2100	3200	2350	4050	3000	3750	2750	4750	3500

DO NOT use these hand torque values if a different torque value or tightening procedure is given for a specific application. Torque values listed are for general use only and include a ±10% variance factor. Check tightness of fasteners periodically. DO NOT use air powered wrenches.

Shear bolts are designed to fail under predetermined loads. Always replace shear bolts with identical grade.

Fasteners should be replaced with the same class. Make sure fastener threads are clean and that you properly start thread engagement. This will prevent them from failing when tightening.

When bolt and nut combination fasteners are used, torque values should be applied to the **NUT** instead of the bolt head.









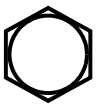

Tighten toothed or serrated-type lock nuts to the full torque value.

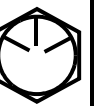
<sup>a</sup> "Lubricated" means coated with a lubricant such as engine oil, or fasteners with phosphate and oil coatings. "Dry" means plain or zinc plated (yellow dichromate - Specification JDS117) without any lubrication.

Reference: JDS—G200.

INCH FASTENER TORQUE VALUES



SAE Grade and Head Markings	1 or 2 <sup>b</sup> No Marks 	5  5.1  5.2 	8  8.2 
	2 No Marks 	5  	8  

TS1162

SIZE	Grade 1				Grade 2 <sup>b</sup>				Grade 5, 5.1 or 5.2				Grade 8 or 8.2			
	Lubricated <sup>a</sup>		Dry <sup>a</sup>		Lubricated <sup>a</sup>		Dry <sup>a</sup>		Lubricated <sup>a</sup>		Dry <sup>a</sup>		Lubricated <sup>a</sup>		Dry <sup>a</sup>	
	N•m	lb-ft	N•m	lb-ft	N•m	lb-ft	N•m	lb-ft	N•m	lb-ft	N•m	lb-ft	N•m	lb-ft	N•m	lb-ft
1/4	3.7	2.8	4.7	3.5	6	4.5	7.5	5.5	9.5	7	12	9	13.5	10	17	12.5
5/16	7.7	5.5	10	7	12	9	15	11	20	15	25	18	28	21	35	26
3/8	14	10	17	13	22	16	27	20	35	26	44	33	50	36	63	46
7/16	22	16	28	20	35	26	44	32	55	41	70	52	80	58	100	75
1/2	33	25	42	31	53	39	67	50	85	63	110	80	120	90	150	115
9/16	48	36	60	45	75	56	95	70	125	90	155	115	175	130	225	160
5/8	67	50	85	62	105	78	135	100	170	125	215	160	215	160	300	225
3/4	120	87	150	110	190	140	240	175	300	225	375	280	425	310	550	400
7/8	190	140	240	175	190	140	240	175	490	360	625	450	700	500	875	650
1	290	210	360	270	290	210	360	270	725	540	925	675	1050	750	1300	975
1-1/8	470	300	510	375	470	300	510	375	900	675	1150	850	1450	1075	1850	1350
1-1/4	570	425	725	530	570	425	725	530	1300	950	1650	1200	2050	1500	2600	1950
1-3/8	750	550	950	700	750	550	950	700	1700	1250	2150	1550	2700	2000	3400	2550
1-1/2	1000	725	1250	925	990	725	1250	930	2250	1650	2850	2100	3600	2650	4550	3350

DO NOT use these hand torque values if a different torque value or tightening procedure is given for a specific application. Torque values listed are for general use only and include a ±10% variance factor. Check tightness of fasteners periodically. DO NOT use air powered wrenches.

Shear bolts are designed to fail under predetermined loads. Always replace shear bolts with identical grade.

Fasteners should be replaced with the same grade. Make sure fastener threads are clean and that you properly start thread engagement. This will prevent them from failing when tightening.

When bolt and nut combination fasteners are used, torque values should be applied to the **NUT** instead of the bolt head.

Tighten toothed or serrated-type lock nuts to the full torque value.

<sup>a</sup> "Lubricated" means coated with a lubricant such as engine oil, or fasteners with phosphate and oil coatings. "Dry" means plain or zinc plated (yellow dichromate - Specification JDS117) without any lubrication.

<sup>b</sup> "Grade 2" applies for hex cap screws (not hex bolts) up to 152 mm (6-in.) long. "Grade 1" applies for hex cap screws over 152 mm (6-in.) long, and for all other types of bolts and screws of any length.

Reference: JDS—G200.

## O-RING SEAL SERVICE RECOMMENDATIONS

### FACE SEAL FITTINGS WITH INCH STUD ENDS TORQUE

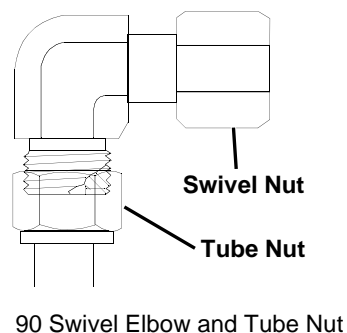
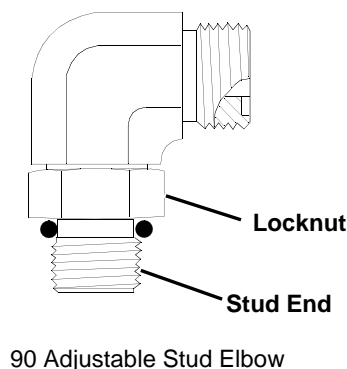
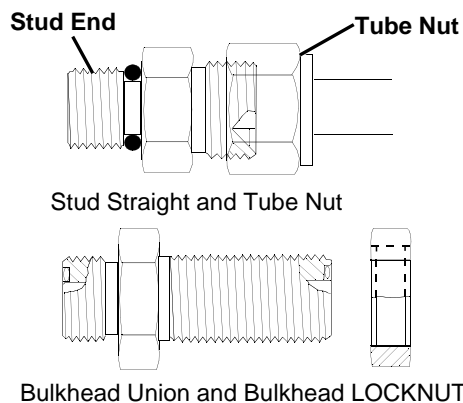

Nominal Tube O.D./Hose I.D.				Face Seal Tube/Hose End					O-ring Stud Ends		
Metric Tube O.D.	Inch Tube O.D.			Thread Size	Tube Nut/ Swivel Nut Torque		Bulkhead Locknut Torque		Thread Size	Straight Fitting or Locknut Torque	
	mm	Dash Size	in.		mm	in.	N•m	lb-ft		N•m	lb-ft
	-3	0.188	4.76						3/8-24	8	6
6	-4	0.250	6.35	9/16-18	16	12	12	9	7/16-20	12	9
8	-5	0.312	7.94						1/2-20	16	12
10	-6	0.375	9.52	11/16-16	24	18	24	18	9/16-18	24	18
12	-8	0.500	12.70	13/16-16	50	37	46	34	3/4-16	46	34
16	-10	0.625	15.88	1-14	69	51	62	46	7/8-14	62	46
	-12	0.750	19.05	1-3/16-12	102	75	102	75	1-1/16-12	102	75
22	-14	0.875	22.22	1-3/16-12	102	75	102	75	1-3/16-12	122	90
25	-16	1.000	25.40	1-7/16-12	142	105	142	105	1-5/16-12	142	105
32	-20	1.25	31.75	1-11/16-12	190	140	190	140	1-5/8-12	190	140
38	-24	1.50	38.10	2-12	217	160	217	160	1-7/8-12	217	160

NOTE: Torque tolerance is + 15 minus 20%.

FACE SEAL FITTINGS WITH METRIC STUD ENDS TORQUE

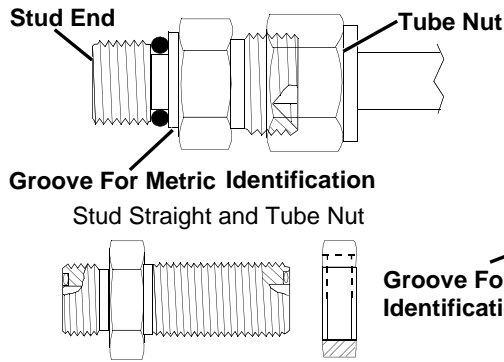

Bulkhead Union and Bulkhead LOCKNUT

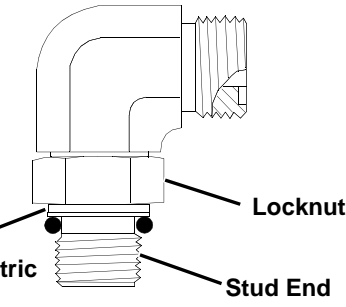

90 Adjustable Stud Elbow

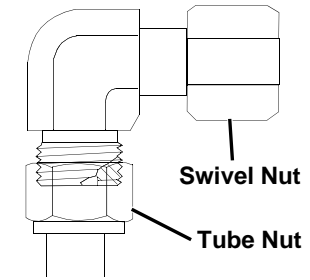

90 Swivel Elbow and Tube Nut

Nominal Tube O.D./Hose I.D.				Face Seal Tube/Hose End						O-ring Stud Ends, Straight Fitting or Locknut					
Metric Tube O.D.	Inch Tube O.D.			Thread Size	Hex Size	Tube Nut/ Swivel Nut Torque		Bulkhead Locknut Torque		Thread Size	Hex Size	Steel or Gray Iron Torque		Aluminum Torque	
	mm	Dash Size	in.			mm	in.	mm	N•m			lb-ft	N•m	lb-ft	mm
6	-4	0.250	6.35	9/16-18	17	16	12	12	9	M12X1.5	17	21	15.5	9	6.6
8	-5	0.312	7.94							M14X1.5	19	33	24	15	11
10	-6	0.375	9.52	11/16-16	22	24	18	24	18	M16X1.5	22	41	30	18	13
12	-8	0.500	12.70	13/16-16	24	50	37	46	34	M18X1.5	24	50	37	21	15
16	-10	0.625	15.88	1-14	30	69	51	62	46	M22X1.5	27	69	51	28	21
	-12	0.750	19.05	1-3/16-12	36	102	75	102	75	M27X2	32	102	75	46	34
22	-14	0.875	22.22	1-3/16-12	36	102	75	102	75	M30X2	36				
25	-16	1.000	25.40	1-7/16-12	41	142	105	142	105	M33X2	41	158	116	71	52
28										M38X2	46	176	130	79	58
32	-20	1.25	31.75	1-11/16-12	50	190	140	190	140	M42X2	50	190	140	85	63
38	-24	1.50	38.10	2-12	60	217	160	217	160	M48X2	55	217	160	98	72

NOTE: Torque tolerance is + 15 minus 20%.

### O-RING FACE SEAL FITTINGS

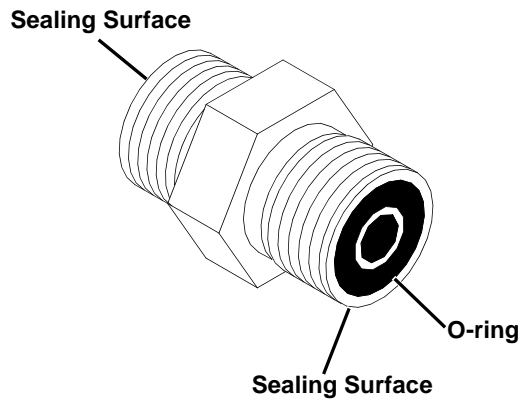

1. Inspect the fitting sealing surfaces. They must be free of dirt or defects.
2. Inspect the O-ring. It must be free of damage or defects.
3. Lubricate O-rings and install into groove using petroleum jelly to hold in place.
4. Push O-ring into the groove with plenty of petroleum jelly so O-ring is not displaced during assembly.
5. Index angle fittings and tighten by hand pressing joint together to insure O-ring remains in place.
6. Tighten fitting or nut to torque value shown on the chart per dash size stamped on the fitting. Do not allow hoses to twist when tightening fittings.

### O-RING BOSS FITTINGS

1. Inspect boss O-ring boss seat. It must be free of dirt and defects. If repeated leaks occur, inspect for defects with a magnifying glass. Some raised defects can be removed with a slip stone.

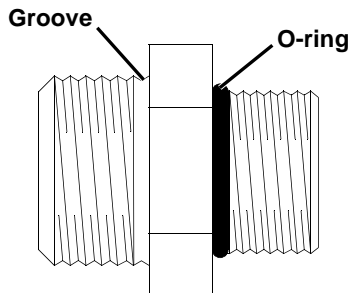

2. Put hydraulic oil or petroleum jelly on the O-ring. Place electrical tape over the threads to protect O-ring from nicks. Slide O-ring over the tape and into the groove of fitting. Remove tape.

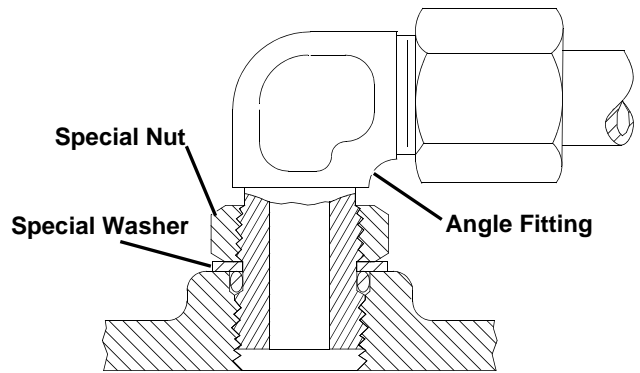

3. For angle fittings, loosen special nut and push special washer against threads so O-ring can be installed into the groove of fitting.
4. Turn fitting into the boss by hand until special washer or washer face (straight fitting) contacts boss face and O-ring is squeezed into its seat.
5. To position angle fittings, turn the fitting counter-clockwise a maximum of one turn.
6. Tighten straight fittings to torque value shown on chart. For angle fittings, tighten the special nut to value shown in the chart while holding body of fitting with a wrench.

#### STRAIGHT FITTING OR SPECIAL NUT TORQUE

Thread Size	Torque <sup>a</sup>		Number of Flats <sup>b</sup>
	N•m	lb-ft	
3/8-24 UNF	8	(6)	2
7/16-20 UNF	12	(9)	2
1/2-20 UNF	16	(12)	2
9/16-18 UNF	24	(18)	2
3/4-16 UNF	46	(34)	2
7/8-14 UNF	62	(46)	1-1/2
1-1/16-12 UN	102	(75)	1
1-3/16-12 UN	122	(90)	1
1-5/16-12 UN	142	(105)	3/4
1-5/8-12 UN	190	(140)	3/4
1-7/8-12 UN	217	(160)	1/2

a. Torque tolerance is ± 10 percent.

b. To be used if a torque wrench cannot be used. After tightening fitting by hand, put a mark on nut or boss; then tighten special nut or straight fitting the number of flats shown.

## DIESEL FUEL SPECIFICATIONS

In general, diesel fuels are blended to satisfy the low air temperature requirements of the geographical area in which they are sold.

In **North America**, diesel fuel is usually specified to **ASTM D975** and sold as either **Grade 1** for cold air temperatures or **Grade 2** for warm air temperatures.

In **Europe**, diesel fuel is usually specified to **EN590** and sold in 5 different classes or 6 different grades.

If diesel fuels being supplied in your area **DO NOT** meet any of the above specifications, use diesel fuels with the following equivalent properties:

- **Cetane Number 40 (minimum)**

A cetane number **greater than 50 is preferred**, especially for air temperatures below  $-20^{\circ}\text{C}$  ( $-4^{\circ}\text{F}$ ) or elevations above 1500 m (5000 ft).

- **Cold Filter Plugging Point (CFPP)**

The temperature at which diesel fuel **begins to cloud or jell**. Use diesel fuels with a CFPP which is at least  $5^{\circ}\text{C}$  ( $9^{\circ}\text{F}$ ) below the expected low air temperature.

- **Sulfur Content of 0.05% (maximum)**

Diesel fuels for highway use in the United States now require sulfur content to be **less than 0.05%**.

If diesel fuel being used has a sulfur content **greater than 0.5%**, **reduce the service interval for engine oil and filter by 50%**.

**Bio-Diesel Fuels** with bio-degradable properties that meet specification DIN 51606 or equivalent may be used.

Consult your local diesel fuel distributor for properties of the diesel fuel available in your area.



## WARNING

**California Proposition 65 Warning:** Diesel engine exhaust and some of its elements from this product are known to the State of California to cause cancer, birth defects, or other reproductive harm.

## LUBRICITY

Diesel fuel must have adequate lubricity to ensure proper operation and durability of fuel injection system components. Fuel lubricity should pass a **minimum of 3300 gram load level** as measured by the **BOCLE** scuffing test.

## STORAGE

**IMPORTANT: DO NOT USE GALVANIZED CONTAINERS**—diesel fuel stored in galvanized containers reacts with zinc coating in the container to form zinc flakes. If fuel contains water, a zinc gel will also form. The gel and flakes will quickly plug fuel filters and damage fuel injectors and fuel pumps.

It is recommended that diesel fuel be stored **ONLY** in a clean, approved **POLYETHYLENE PLASTIC** container **WITHOUT** any metal screen or filter. This will help prevent any accidental sparks from occurring. Store fuel in an area that is well ventilated to prevent possible igniting of fumes by an open flame or spark, this includes any appliance with a pilot light.

**IMPORTANT: Keep all dirt, scale, water or other foreign material out of fuel.**

Keep fuel in a safe, protected area and in a clean, properly marked ("**DIESEL FUEL**") container. **DO NOT** use de-icers to attempt to remove water from fuel. **DO NOT** depend on fuel filters to remove water from fuel. It is recommended that a water separator be installed in the storage tank outlet. **BE SURE** to properly discard unstable or contaminated diesel fuel and/or their containers when necessary.

# LUBRICANTS

## ENGINE OIL SPECIFICATIONS

### 4-CYCLE DIESEL ENGINE OIL – NORTH AMERICA

Use the appropriate oil viscosity based on the expected air temperature range during the period between recommended oil changes. Operating outside of these recommended oil air temperature ranges may cause premature engine failure.

The following John Deere oils are **PREFERRED**:

- **PLUS-50®—SAE 15W-40;**
- **TORQ-GARD SUPREME®—SAE 5W-30.**

The following John Deere oils are **also recommended**, based on their specified temperature range:

- **TURF-GARD®—SAE 10W-30;**
- **PLUS-4®—SAE 10W-30;**
- **TORQ-GARD SUPREME®—SAE 30.**

Other oils may be used if above John Deere oils are not available, provided they meet one of the following specifications:

- SAE 15W-40—API Service Classification CF-4 or higher;
- SAE 5W-30—API Service Classification CC or higher;
- SAE 10W-30—API Service Classification CF or higher;
- SAE 30—API Service Classification CF or higher.

**IMPORTANT:** If diesel fuel with sulfur content greater than 0.5% is used, reduce the service interval for oil and filter by 50%.

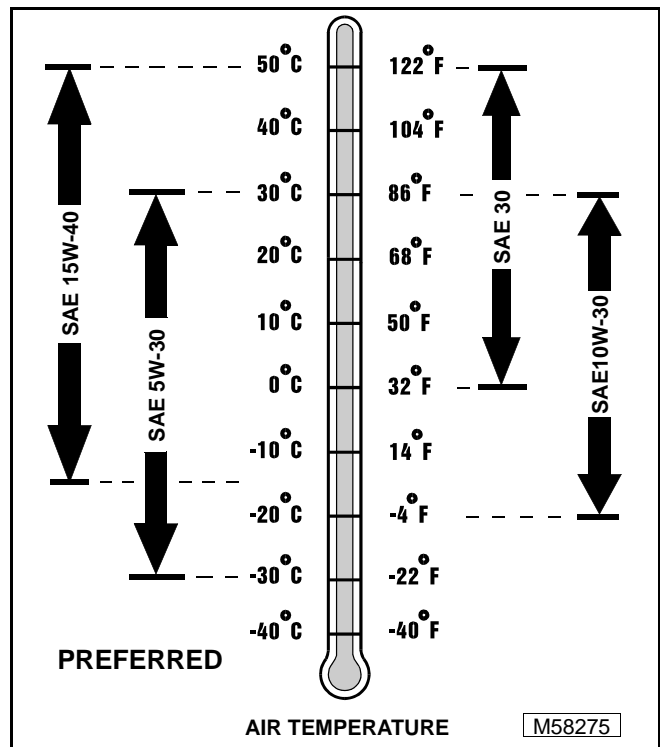

### 4-CYCLE DIESEL ENGINE OIL – EUROPE

Use the appropriate oil viscosity based on the expected air temperature range during the period between recommended oil changes. Operating outside of these recommended oil air temperature ranges may cause premature engine failure.

The following John Deere oils are **PREFERRED**:

- TORQ-GARD SUPREME®—SAE 15W-40;
- UNI-GARD™—SAE 15W-40;
- TORQ-GARD SUPREME®—SAE 5W-30;
- UNI-GARD™—SAE 5W-30.

The following John Deere oils are **also recommended**, based on their specified temperature range:

- TORQ-GARD SUPREME®—SAE 10W-30;
- UNI-GARD™—SAE 10W-30;
- TORQ-GARD SUPREME®—SAE 30;
- UNI-GARD™—SAE 30.

Other oils may be used if above John Deere oils are not available, provided they meet one of the following specifications:

- CCMC Specification D4 or Mercedes Benz MB228.1 or higher.

**IMPORTANT:** If diesel fuel with sulfur content greater than 0.5% is used, reduce the service interval for oil and filter by 50%.

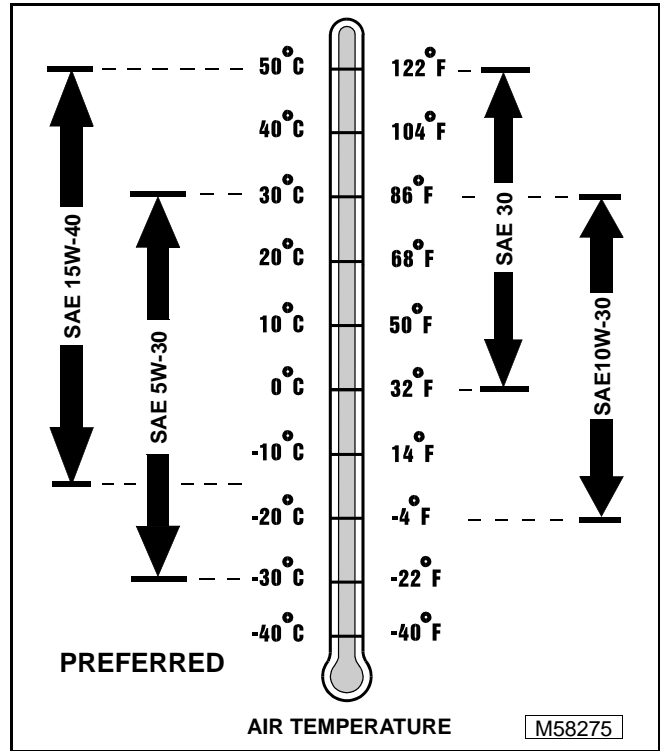

## BREAK-IN DIESEL ENGINE OIL – NORTH AMERICA

**IMPORTANT:** ONLY use this specified break-in oil in rebuilt or remanufactured engines for the first 100 hours (maximum) of operation. DO NOT use PLUS-50®, SAE 15W40 oil or oils meeting specifications API CG-4 or API CF-4, these oils will not allow rebuilt or remanufactured engines to break-in properly.

The following John Deere oil is **PREFERRED**:

- **BREAK-IN ENGINE OIL.**

**John Deere BREAK-IN ENGINE OIL** is formulated with special additives for aluminum and cast iron type engines to allow the power cylinder components (pistons, rings, and liners as well) to “wear-in” while protecting other engine components, valve train and gears, from abnormal wear. Engine rebuild instructions should be followed closely to determine if special requirements are necessary.

**John Deere BREAK-IN ENGINE OIL** is also recommended for non-John Deere engines, both aluminum and cast iron types.

If this preferred John Deere oil is not available, use a break-in engine oil meeting the following specification during the first 100 hours of operation:

- API Service Classification CE or higher.

**IMPORTANT:** After the break-in period, use the John Deere oil that is recommended for this engine.

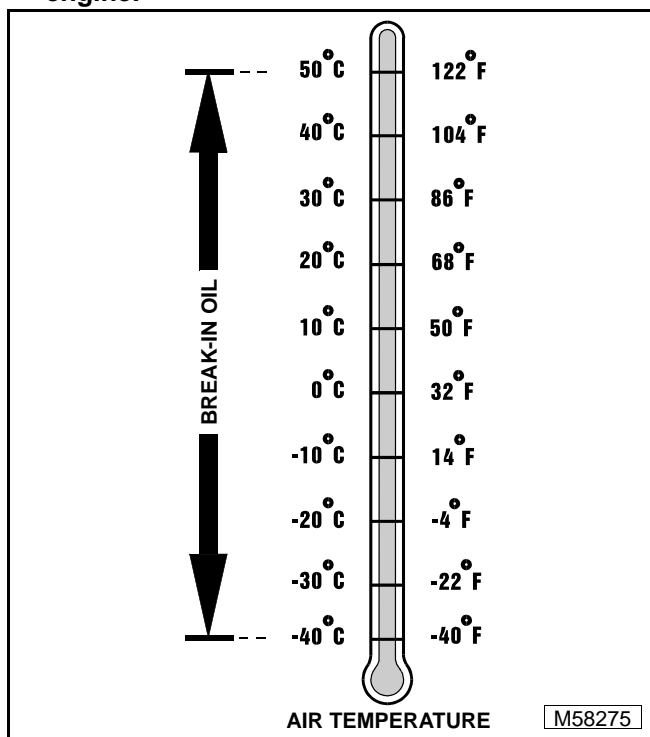

## BREAK-IN DIESEL ENGINE OIL – EUROPE

**IMPORTANT:** ONLY use this specified break-in oil in rebuilt or remanufactured engines for the first 100 hours (maximum) of operation. DO NOT use SAE 15W-40 oil or oils meeting CCMC Specification D5—these oils will not allow rebuilt or remanufactured engines to break-in properly.

The following John Deere oil is **PREFERRED**:

- **BREAK-IN ENGINE OIL.**

**John Deere BREAK-IN ENGINE OIL** is formulated with special additives for aluminum and cast iron type engines to allow the power cylinder components (pistons, rings, and liners as well) to “wear-in” while protecting other engine components, valve train and gears, from abnormal wear. Engine rebuild instructions should be followed closely to determine if special requirements are necessary.

**John Deere BREAK-IN ENGINE OIL** is also recommended for non-John Deere engines, both aluminum and cast iron types.

If above preferred John Deere oil is not available, use a break-in engine oil meeting the following specification during the first 100 hours of operation:

- CCMC Specification D4 or higher.

**IMPORTANT:** After the break-in period, use the John Deere oil that is recommended for this engine.

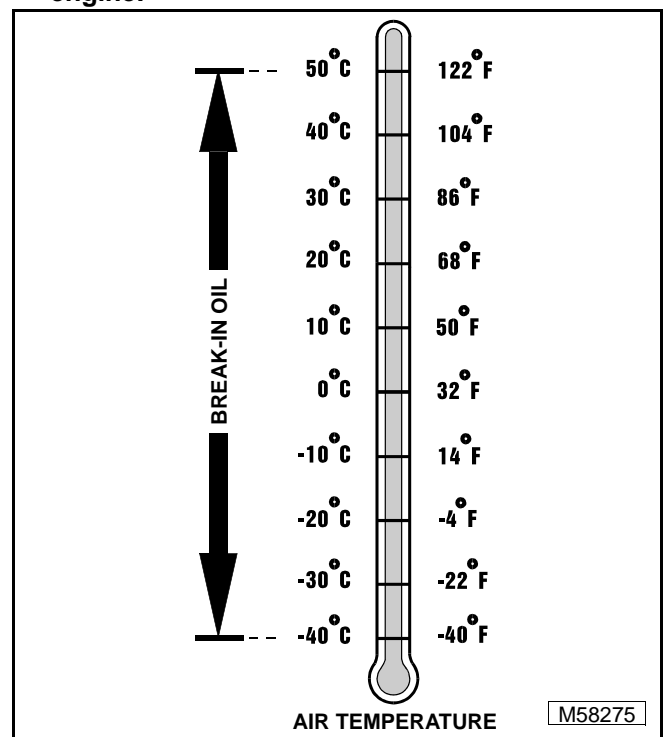

## HYDROSTATIC TRANSMISSION AND HYDRAULIC OIL

**IMPORTANT:** ONLY use a quality SAE 10W-30 SYNTHETIC engine oil in this transmission. Mixing of two viscosity grade oils is NOT RECOMENDED. DO NOT use BIO-HY-GARD® in this transmission.

The following John Deere transmission and hydraulic oil is **PREFERRED**:

- John Deere Low Viscosity HY-GARD™ J20D.

Other oils may be used if above recommended John Deere oils are not available. Use only oils that meet one of the following specifications:

- John Deere Standard JDM J20D;
- John Deere Standard JDM J20C.
- CCMC Specifications G4 or higher.

Use the appropriate oil viscosity based on these air temperature ranges. Operating outside of these recommended oil air temperature ranges may cause premature hydrostatic transmission failure.

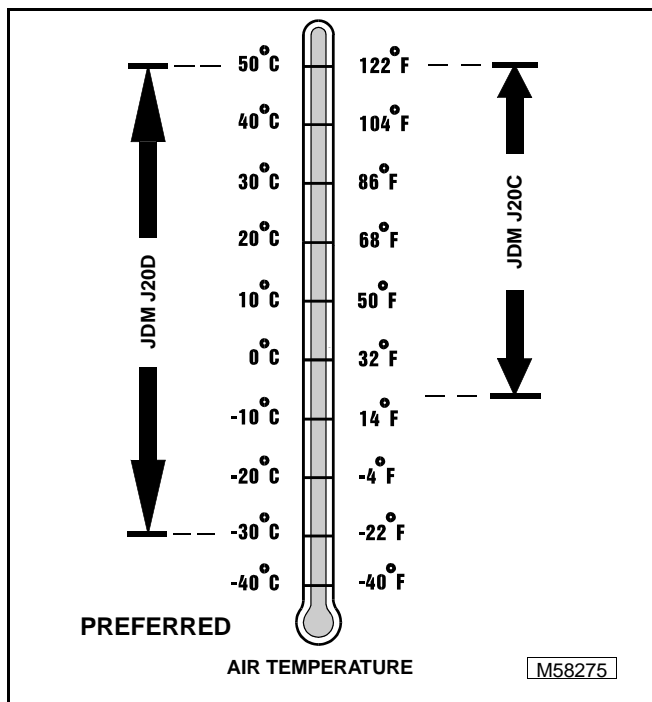

**John Deere Dealers:** You may want to cross-reference the following publications to recommend the proper oil for your customers:

- Module DX, ENOIL2 in JDS-G135;
- Section 530, Lubricants & Hydraulics, of the John Deere Merchandise Sales Guide;
- Lubrication Sales Manual PI7032.

Use only oils that meet the following specifications:

- API Service Classifications SG or higher.

## ANTI-CORROSION GREASE SPECIFICATIONS

This anti-corrosion grease is formulated to provide the best protection against absorbing moisture, which is one of the major causes of corrosion. This grease is also superior in its resistance to separation and migration.

The following anti-corrosion grease is **PREFERRED**:

- DuBois MPG-2® Multi-Purpose Polymer Grease—M79292.

Other greases may be used if they meet or exceed the following specifications:

- John Deere Standard JDM J13A2, NLGI Grade 1.

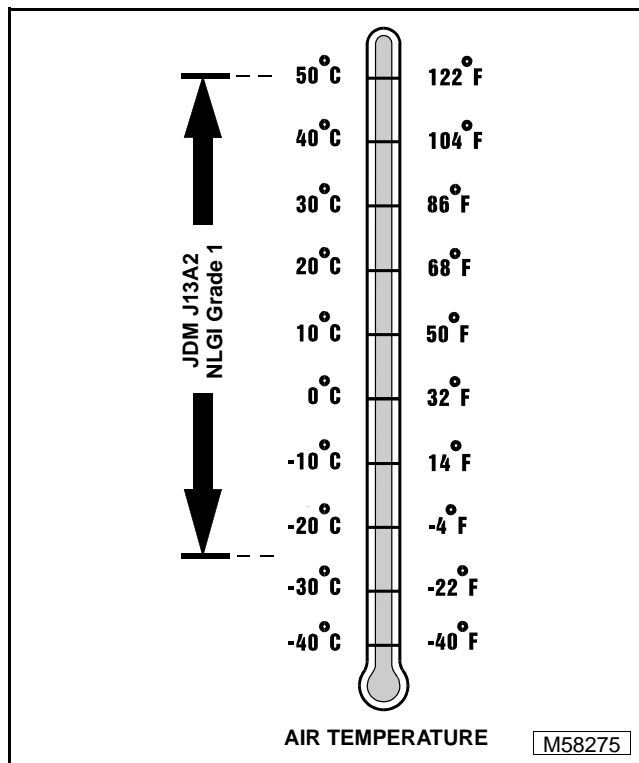

## ALTERNATIVE LUBRICANTS

Conditions in certain geographical areas outside the United States and Canada may require different lubricant recommendations than the ones printed in this technical manual or the operator's manual. Consult with your John Deere Dealer, or Sales Branch, to obtain the alternative lubricant recommendations.

**IMPORTANT: Use of alternative lubricants could cause reduced life of the component.**

If alternative lubricants are to be used, it is recommended that the factory fill be thoroughly removed before switching to any alternative lubricant.

## SYNTHETIC LUBRICANTS

Synthetic lubricants may be used in John Deere equipment if they meet the applicable performance requirements (industry classification and/or military specification) as shown in this manual.

The recommended air temperature limits and service or lubricant change intervals should be maintained as shown in the operator's manual.

Avoid mixing different brands, grades, or types of oil. Oil manufacturers blend additives in their oils to meet certain specifications and performance requirements. Mixing different oils can interfere with the proper functioning of these additives and degrade lubricant performance.

## LUBRICANT STORAGE

All machines operate at top efficiency only when clean lubricants are used. Use clean storage containers to handle all lubricants. Store them in an area protected from dust, moisture, and other contamination. Store drums on their sides. Make sure all containers are properly marked as to their contents. Dispose of all old, used containers and their contents properly.

## MIXING OF LUBRICANTS

In general, avoid mixing different brands or types of lubricants. Manufacturers blend additives in their lubricants to meet certain specifications and performance requirements. Mixing different lubricants can interfere with the proper functioning of these additives and lubricant properties which will downgrade their intended specified performance.

## CHASSIS GREASE

Use the following grease based on the air temperature range. Operating outside of the recommended grease air temperature range may cause premature failures.

**IMPORTANT: ONLY use a quality grease in this application. DO NOT mix any other greases in this application. DO NOT use any BIO-GREASE in this application.**

The following John Deere grease is **PREFERRED**:

- **NON-CLAY HIGH-TEMPERATURE EP GREASE®—JDM J13E4, NLGI Grade 2.**
- **GREASE-GARD™—JDM J13E4, NLGI Grade 2.**

Other greases may be used if above preferred John Deere grease is not available, provided they meet the following specification:

- John Deere Standard JDM J13E4, NLGI Grade 2.

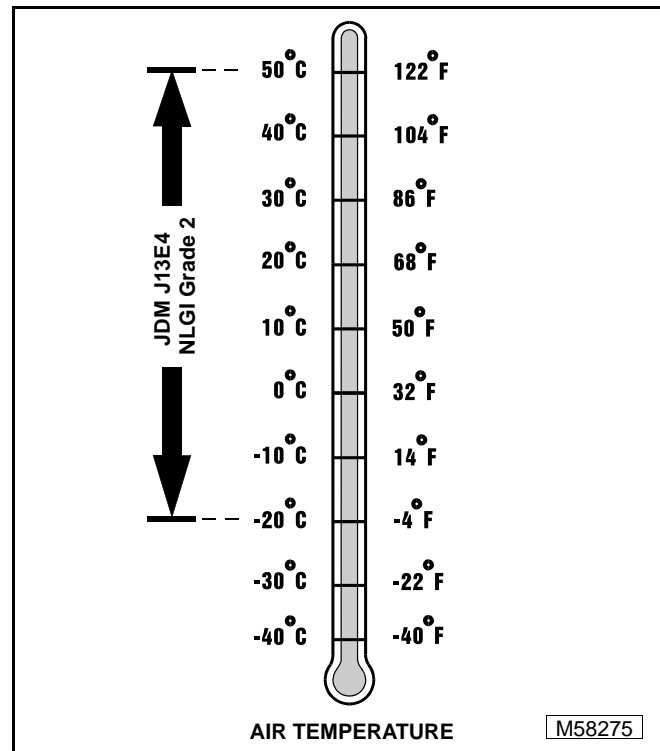

**John Deere Dealers:** You may want to cross-reference the following publications to recommend the proper grease for your customers:

- Module DX,GREA1 in JDS-G135;
- Section 530, Lubricants & Hydraulics, of the John Deere Merchandise Sales Guide;
- Lubrication Sales Manual P17032.

## COOLANT SPECIFICATIONS

### DIESEL AND GASOLINE ENGINE COOLANT – NORTH AMERICA

The engine cooling system when filled with a proper dilution mixture of anti-freeze and deionized or distilled water provides year-round protection against corrosion, cylinder or liner pitting, and winter freeze protection down to  $-37^{\circ}\text{C}$  ( $-34^{\circ}\text{F}$ ).

The following John Deere coolant is **PREFERRED**:

- **PRE-DILUTED DIESEL ENGINE ANTI-FREEZE/SUMMER COOLANT™ (TY16036).**

This coolant satisfies specifications for “Automobile and Light Duty Engine Service” and is safe for use in John Deere Lawn and Grounds Care/Golf and Turf Division equipment, including aluminum block gasoline engines and cooling systems.

The above preferred pre-diluted anti-freeze provides:

- adequate heat transfer
- corrosion-resistant chemicals for the cooling system
- compatibility with cooling system hose and seal material
- protection during extreme cold and extreme hot weather operations
- chemically pure water for better service life
- compliance with ASTM D4656 (JDM H24C2) specifications

If above preferred pre-diluted coolant is not available, the following John Deere concentrate is **recommended**:

- **DIESEL ENGINE ANTI-FREEZE/SUMMER COOLANT CONCENTRATE™ (TY16034).**

If either of above recommended engine coolants are available use any Automobile and Light Duty Engine Service **ethylene glycol base coolant**, meeting the following specification:

- ASTM D3306 (JDM H24C1).

Read container label completely before using and follow instructions as stated.

**IMPORTANT:** To prevent engine damage, **DO NOT** use pure anti-freeze or less than a 50% anti-freeze mixture in the cooling system. **DO NOT** mix or add any additives/conditioners to the cooling system in Lawn and Grounds Care/Golf and Turf Division equipment. Water used to dilute engine coolant concentrate must be of **high quality—clean, clear, potable water (low in chloride and hardness—Table 1) is generally acceptable.** **DO NOT** use salt water. Deionized or distilled water is ideal to use. Coolant that is not mixed to these specified levels and water purity can cause excessive scale, sludge deposits, and increased corrosion potential.

#### Water Quality

Property	Requirements
Total Solids, Maximum	340 ppm (20 grns/gal)
Total Hardness, Max.	170 ppm (10 grns/gal)
Chloride (as Cl), Max.	40 ppm (2.5 grns/gal)
Sulfate (as $\text{SO}_4$ ), Max.	100 ppm (5.8 grns/gal)

Mix 50 percent anti-freeze concentrate with 50 percent distilled or deionized water. This mixture and the pre-diluted mixture (TY16036) will protect the cooling system down to  $-37^{\circ}\text{C}$  ( $-34^{\circ}\text{F}$ ) and up to  $108^{\circ}\text{C}$  ( $226^{\circ}\text{F}$ ).

Certain geographical areas may require lower air temperature protection. See the label on your anti-freeze container or consult your John Deere dealer to obtain the latest information and recommendations.

### DIESEL AND GASOLINE ENGINE COOLANT DRAIN INTERVAL – NORTH AMERICA

When using **John Deere Pre-Diluted (TY16036)** Automobile and Light Duty Engine Service coolants, drain and flush the cooling system and refill with fresh coolant mixture every **36 months or 3,000 hours** of operation, whichever comes first.

When using **John Deere Concentrate (TY16034)** Automobile and Light Duty Engine Service coolants, drain and flush the cooling system and refill with fresh coolant mixture every **24 months or 2,000 hours** of operation, whichever comes first.

If above John Deere Automobile and Light Duty Engine Service coolants **are not** being used; drain, flush, and refill the cooling system according to instructions found on product container or in equipment operator’s manual or technical manual.

## DIESEL ENGINE COOLANT – EUROPE

The engine cooling system when filled with a proper dilution mixture of anti-freeze and deionized or distilled water provides year-round protection against corrosion, cylinder liner pitting, and winter freeze protection down to  $-37^{\circ}\text{C}$  ( $-34^{\circ}\text{F}$ ).

The following John Deere coolant is **PREFERRED**:

- **COOL-GARD COOLANT CONCENTRATE™**.

If above preferred coolant is not available, use any Automobile and Light Duty Engine Service **ethylene glycol base coolant**, meeting the following specification:

- ASTM D3306 (JDM H24C1).

Read container label completely before using and follow instructions as stated.

**IMPORTANT: To prevent engine damage, DO NOT use pure anti-freeze or less than a 50% anti-freeze mixture in the cooling system. DO NOT mix or add any additives/conditioners to the cooling system in Lawn and Grounds Care/Golf and Turf Division equipment. Water used to dilute engine coolant concentrate must be of high quality—clean, clear, potable water (low in chloride and hardness—Table 1) is generally acceptable. DO NOT use salt water. Deionized or distilled water is best to use. Coolant that is not mixed to these specified levels and water purity can cause excessive scale, sludge deposits, and increased corrosion potential.**

### Water Quality

Property	Requirements
Total Solids, Maximum	340 ppm (20 grns/gal)
Total Hardness, Max.	170 ppm (10 grns/gal)
Chloride (as Cl), Max.	40 ppm (2.5 grns/gal)
Sulfate (as $\text{SO}_4$ ), Max.	100 ppm (5.8 grns/gal)

Mix 50 percent anti-freeze concentrate with 50 percent distilled or deionized water. This mixture will protect the cooling system down to  $-37^{\circ}\text{C}$  ( $-34^{\circ}\text{F}$ ) and up to  $108^{\circ}\text{C}$  ( $226^{\circ}\text{F}$ ).

Certain geographical areas may require lower air temperature protection. See the label on your anti-freeze container or consult your John Deere dealer to obtain the latest information and recommendations.

## DIESEL ENGINE COOLANT DRAIN INTERVAL – EUROPE

When using **John Deere Cool-Gard Coolant Concentrate** for Automobile and Light Duty Engine Service, drain and flush the cooling system and refill with fresh coolant mixture every **24 months or 2,000 hours** of operation, whichever comes first.

If above John Deere Automobile and Light Duty Engine Service coolant **is not** being used; drain, flush, and refill the cooling system according to instructions found on product container or in equipment operator's manual or technical manual.



### SERIAL NUMBER LOCATION

When ordering parts or submitting a warranty claim, it is **IMPORTANT** that the machine product identification number and component serial numbers are included.



The location of the machine identification number and component serial numbers are shown.

### MACHINE IDENTIFICATION NUMBER

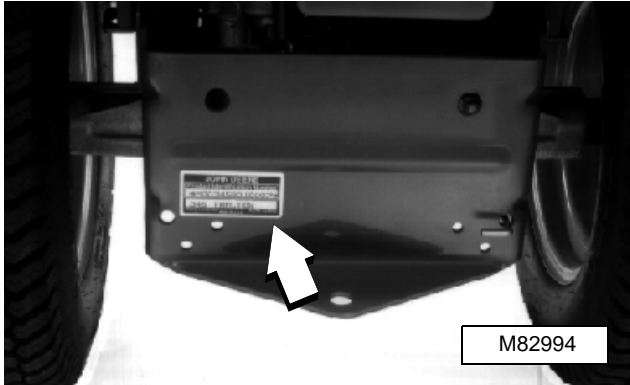

### HYDROSTATIC TRANSMISSION SERIAL NUMBER

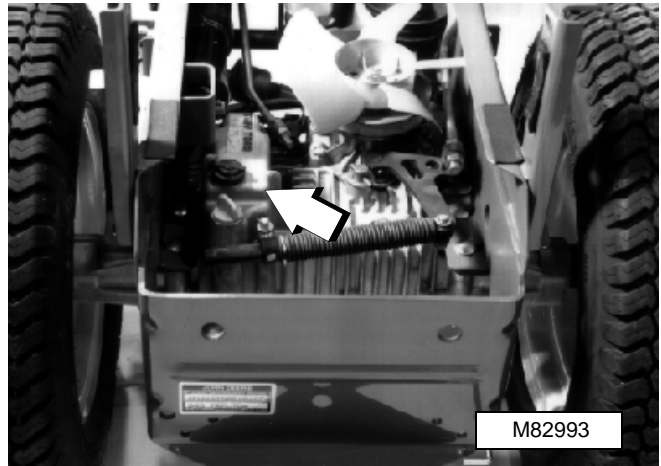

### ENGINE SERIAL NUMBER



**DIESEL ENGINE****SPECIFICATIONS**

GENERAL ENGINE SPECIFICATIONS .....	3
TEST AND ADJUSTMENT SPECIFICATIONS .....	3
REPAIR SPECIFICATIONS .....	3
SPECIAL OR ESSENTIAL TOOLS .....	6
OTHER MATERIALS .....	6

**COMPONENT LOCATION AND OPERATION .....** 7**ENGINE COMPONENT LOCATION .....** 7**COOLING SYSTEM OPERATION .....** 9**FUEL SYSTEM OPERATION .....** 10**LUBRICATION SYSTEM OPERATION .....** 11**DIESEL ENGINE TROUBLESHOOTING CHART .....** 12**DIAGNOSIS**

ENGINE SYSTEM .....	15
---------------------	----

**CHECKS, TESTS AND ADJUSTMENTS**

CYLINDER COMPRESSION TEST .....	17
SLOW IDLE ADJUSTMENT .....	18
FAST IDLE ADJUSTMENT .....	18
THROTTLE CABLE ADJUSTMENT .....	19
FUEL INJECTION PUMP TIMING ADJUSTMENT .....	19
RADIATOR BUBBLE TEST .....	23
COOLING SYSTEM PRESSURE TEST .....	23
VALVE CLEARANCE CHECK AND ADJUSTMENT .....	24
RADIATOR CAP PRESSURE TEST .....	25
THERMOSTAT OPENING TEST .....	25
ENGINE OIL PRESSURE TEST .....	26

**REPAIR**

ENGINE—REMOVE AND INSTALL .....	27
ENGINE MOUNTS AND ISOLATORS— POSITION AND TORQUE .....	28
AIR FILTER—REMOVE AND INSTALL .....	28
MUFFLER—REMOVE AND INSTALL .....	29
INTAKE MANIFOLD—REMOVE AND INSTALL .....	29
OIL PRESSURE SENSOR—REMOVE AND INSTALL .....	30
THERMOSTAT—REMOVE AND INSTALL .....	30
COOLANT TEMPERATURE SENSOR— REMOVE AND INSTALL .....	31
RADIATOR—REMOVE AND INSTALL .....	32
FUEL SHUTOFF SOLENOID—REMOVE AND INSTALL .....	33
FUEL HOSES—REMOVE AND INSTALL .....	33
FUEL PUMP—REMOVE AND INSTALL .....	34
FUEL FILTER—REMOVE AND INSTALL .....	34
FUEL INJECTORS—EXPLODED VIEW .....	36
FUEL INJECTORS—REMOVE AND INSTALL .....	36
FUEL INJECTORS—TEST .....	37
INJECTION PUMP—REMOVE AND INSTALL .....	38





	Page
INJECTION PUMP GOVERNOR ASSEMBLY— REMOVE AND INSTALL .....	38
INJECTION PUMP GOVERNOR— DISASSEMBLE AND ASSEMBLE .....	39
FAN/FLYWHEEL—REMOVE AND INSTALL .....	41
ROCKER ARM COVERS—REMOVE AND INSTALL .....	42
ROCKER ARMS—REMOVE AND INSTALL .....	42
NUMBER 1 CYLINDER HEAD—REMOVE AND INSTALL .....	44
NUMBER 2 CYLINDER HEAD—REMOVE AND INSTALL .....	45
CYLINDER HEAD AND VALVES— DISASSEMBLE AND INSPECT .....	46
CYLINDER HEAD AND VALVES—ASSEMBLY .....	49
CRANKCASE BREATHER—REMOVE AND INSTALL .....	50
CRANKCASE COVER—REMOVE AND INSTALL .....	50
WATER PUMP—REMOVE AND INSTALL .....	51
OIL PUMP—REMOVE AND INSTALL .....	52
CAMSHAFT—REMOVE AND INSTALL .....	54
PISTON AND CONNECTING ROD—REMOVE AND INSTALL .....	58
CRANKSHAFT—REMOVE AND INSTALL .....	62
STATOR—REMOVAL AND INSTALLATION .....	64
STARTER SOLENOID—REMOVE AND REPLACE .....	64
STARTER MOTOR—REMOVAL AND INSTALLATION .....	65
STARTER MOTOR— DISASSEMBLE, INSPECT AND ASSEMBLE .....	65

## SPECIFICATIONS

### GENERAL ENGINE SPECIFICATIONS

Engine Model	2V78 - 2008D001
Type	V-Twin, Vertical Shaft, 4-Cycle, Aluminum Block, Isolated Mount, Liquid Cooled, Diesel Engine
Number of Cylinders	2 OHV
Cylinder Bore x Stroke	78 mm (3.071 in.) x 78.4 mm (3.087 in.)
Displacement	0.749 L (45.7 cu. in.)
Rated Output	12.0 kW (16.1 hp) at 2800 rpm 12.8 kW (17.2 hp) at 3000 rpm 13.5 kW (18.1 hp) at 3200 rpm 14.2 kW (19.0 hp) at 3400 rpm 14.9 kW (20.0 hp) at 3600 rpm
Engine Lubricating System	Pressure lubrication with trochoid pump
Applicable Lubrication	API grade CC, CD or CF class or higher
Crankcase Lubricant Capacity	2.27 L (2.4 qt)
Cooling System	Liquid cooled
Coolant Capacity	3.6 L (3.8 U.S. qt)
Coolant Recovery Tank Capacity	0.3 L (0.3 U.S. qt)



### TESTS AND ADJUSTMENTS SPECIFICATIONS

#### Engine:

Standard Compression	3040 ± 196 kPa (441 ± 28 psi)
Maximum Difference between Cylinders	294 kPa (43 psi)
Minimum Cranking Speed	250 rpm
Slow Idle Speed	1000 ± 50 rpm
Valve Lifter Travel	6.86 mm (0.270 in.) minimum
Valve Clearance (cold)	0.1 ± 0.05 mm (0.004 ± 0.002 in.)
Cooling System Pressure	88 kPa (12.8 psi) minimum
Thermostat	
Opening Temperature	80.5—85.5°C (177—182°F)
Fully Open Temperature	95°C (203°F)
Oil Pressure	241 kPa (35 psi) @ 3250 rpm

#### Starter:

Brush Length	7.70 mm (0.303 in.) minimum
--------------	-----------------------------

### REPAIR SPECIFICATIONS

#### Cylinder Head:

Combustion Surface Distortion	
Standard	0.05 mm (0.002 in.)
Limit	0.15 mm (0.006 in.)
Valve Sink Below Head Surface (Intake and Exhaust)	
Standard	0.5 mm ± 0.1 (0.02 in. ± 0.04 in.)
Limit	1.0 mm (0.039 in.)
Valve Seat Angle (Intake and Exhaust)	45°

**REPAIR SPECIFICATIONS (Continued)**

**Cylinder Head: (Continued)**

Intake Valve Seat Outside Dia. . . . .	33.598—33.614 mm (1.322—1.323 in.)
Head Intake Valve Bore Inside Dia. . . . .	33.500—33.516 mm (1.318—1.319 in.)
Exhaust Valve Seat Outside Dia. . . . .	28.086—28.096 mm (1.105—1.106 in.)
Head Exhaust Valve Bore Inside Dia. . . . .	28.000—28.013 mm (1.102—1.103 in.)
Intake/Exhaust Valve Guide Outside Dia. . . . .	10.039—10.050 mm (0.395—0.396 in.)
Head Valve Guide Bore Inside Dia. . . . .	10.000—10.015 mm (0.393—0.394 in.)
Intake and Exhaust Valve Guide Protrusion Below Bonnet Installation Surface . . . . .	7 mm (0.276 in.)
Rocker Shaft Bore Inside Dia. Standard. . . . .	11.988—12.006 mm (0.471—0.472 in.)
Limit . . . . .	12.007 mm (0.473 in.)
Rocker Shaft Outside Dia. Standard. . . . .	11.966—11.984 mm (0.471—0.472 in.)
Limit . . . . .	11.950 mm (0.470 in.)

**Intake and Exhaust Valves:**

Intake Valve Outside Dia. . . . .	32.500 mm (1.279 in.)
Intake Valve Stem Outside Dia. Standard. . . . .	5.960—5.975 mm (0.234—0.235 in.)
Limit . . . . .	5.900 mm (0.232 in.)
Exhaust Valve Outside Dia. . . . .	27.000 mm (1.063 in.)
Exhaust Valve Stem Outside Dia. Standard. . . . .	5.945—5.960 mm (0.234—0.235 in.)
Limit . . . . .	5.900 mm (0.232 in.)

**Intake and Exhaust Valve Guides:**

Valve Guide Inside Dia. Standard. . . . .	6.000—6.012 mm (0.236—0.237 in.)
Limit . . . . .	6.07 mm (0.238 in.)

**Camshaft:**

Camshaft Straightness Standard. . . . .	0—0.02 mm (0—0.001 in.)
Limit . . . . .	0.05 mm (0.002 in.)
Camshaft Lobe Height Intake and Exhaust Lobe . . . . .	31.13—31.19 mm (1.225—1.227 in.)
Fuel Lobe . . . . .	30.90—31.10 mm (1.216—1.224 in.)
Camshaft Outside Dia. (Block Side) Standard. . . . .	15.94—15.96 mm (0.627—0.628 in.)
Limit . . . . .	15.86 mm (0.624 in.)
Camshaft Outside Dia. (Crankcase Cover Side) Standard. . . . .	23.94—23.96 mm (0.942—0.943 in.)
Limit . . . . .	23.86 mm (0.939 in.)
Camshaft Bearing Inside Dia. (Block Side) Standard. . . . .	16.00—16.025 mm (0.630—0.631 in.)
Limit . . . . .	16.04 mm (0.632 in.)
Camshaft Bearing Inside Dia. (Crankcase Cover Side) Standard. . . . .	24.00—24.025 mm (0.945—0.946 in.)
Limit . . . . .	24.04 mm (0.946 in.)
Camshaft Gear Backlash-to-Crank Gear . . . . .	0.067—0.127 mm (0.002—0.005 in.)
Camshaft Gear Backlash-to-Oil Pump Gear . . . . .	0.25—0.50 mm (0.009—0.019 in.)

## REPAIR SPECIFICATIONS (Continued)

### Cylinder Block:

Cylinder Bore Inside Dia.	
Standard . . . . .	78.00—78.02 mm (3.070—3.072 in.)
Limit . . . . .	78.20 mm (3.079 in.)
Cylinder Bore Roundness	
Standard . . . . .	0.01—0.03 mm (0—0.001 in.)
Cylinder Block Crankshaft Bore	
Inside Dia. . . . .	54.00—54.016 mm (2.125—2.126 in.)
Cylinder Block Crankshaft Bearing	
Outside Dia. . . . .	54.090—54.130 mm (2.129—2.131 in.)

### Crankcase Cover:

Crankshaft Bore Inside Dia. . . . .	54.00—54.016 mm (2.125—2.126
Crankshaft Bearing Outside Dia. . . . .	54.090—54.130 mm (2.129—2.131 in.)

### Crankshaft:

Connecting Rod Journal Outside Dia.	
Standard . . . . .	39.97—39.98 mm (1.573—1.574 in.)
Limit . . . . .	39.91 mm (1.571 in.)
Main Bearing Journals Outside Dia.	
Block and Crankcase Cover End	
Standard . . . . .	49.99 mm (1.968 in.)
Limit . . . . .	49.94 mm (1.966 in.)

### Connecting Rod:

Small End Inside Diameter. . . . .	18.97 mm (0.747 in.)
Large End Inside Diameter . . . . .	40.03 mm (1.576 in.)

### Piston:

Piston Outside Dia.	
Standard . . . . .	77.926—77.936 mm (3.067—3.068 in.)
Limit . . . . .	77.87 mm (3.066 in.)
Piston Pin Outside Dia. . . . .	18.99 mm (0.748 in.)
Piston Ring Groove Width	
Top Ring . . . . .	1.290 mm (0.050 in.)
Second Ring . . . . .	1.550 mm (0.061 in.)
Oil Ring . . . . .	3.030 mm (0.119 in.)

### Rings:

Top Ring Width . . . . .	1.210 mm (0.047 in.)
Second Ring Width . . . . .	1.49 mm (0.068 in.)
Oil Ring Width . . . . .	2.97 mm (0.116 in.)

### Rocker Arms:

Intake and Exhaust Valve Rocker Arms Outside Stem Dia.	
Standard . . . . .	6.98 mm (0.275 in.)
Limit . . . . .	6.92 mm (0.272 in.)
Fuel Valve Rocker Arms Outside Dia.	
Standard . . . . .	20.993 mm (0.826 in.)
Limit . . . . .	20.94 mm (0.824 in.)



**REPAIR SPECIFICATIONS (Continued)**

**Rocker Arms: (Continued)**

Intake and Exhaust Valves Rocker Arm Inside Dia.	
Standard.....	12.02 mm (0.472 in.)
Limit.....	12.09 mm (0.476 in.)
Rocker Arm Shaft Outside Dia.	
Standard.....	11.984 mm (0.472 in.)
Limit.....	11.95 mm (0.470 in.)



**Oil Pump:**

Outer Rotor Outside Dia.....	40.56 mm (1.596 in.)
Crankcase Cover Outer Rotor Bore Dia.....	40.68 mm (1.601 in.)
Crankcase Cover Outer Rotor Bore Depth.....	12.06 mm (0.474 in.)
Oil Pump Drive Shaft Dia.	
Standard.....	10.984 mm (0.432 in.)
Limit.....	10.95 mm (0.431 in.)
Oil Pump Drive Shaft Crankcase Cover Bore Dia.	
Standard.....	11.018 mm (0.433 in.)
Limit.....	11.07 mm (0.435 in.)

**Coolant Pump:**

Shaft Dia	
Standard.....	12.00 mm (0.472 in.)
Limit.....	11.94 mm (0.470 in.)
Crankcase Cover Bore Dia.	
Standard.....	12.119 mm (0.477 in.)
Limit.....	12.17 mm (0.479 in.)

**Flywheel:**

Flywheel Surface Runout (Maximum).....	0.10 mm (0.004 in.)
--	---------------------

**TORQUE SPECIFICATIONS (Aluminum Block)**

Engine Mounting Plate Cap Screws.....	36 - 43 N•m (313 - 381 lb-in.)
Engine Mounting Bolts.....	54 N•m (40 lb-ft.)
Engine Isolator Bolts.....	72 N•m (53 lb-ft.)
PTO Clutch Mounting Bolt.....	73 N•m (54 lb-ft.)
Radiator Mounting Cap Screws.....	35 N•m (309 lb-in.)
Water Pump Cap Screws.....	8 - 9 N•m (70 - 86 lb-in.)
Oil Pump Cap Screws.....	8 - 9 N•m (70 - 86 lb-in.)
Rocker Arm Cover Cap Screws.....	20 - 22 N•m (178 - 194 lb-in.)
Cylinder Head Cap Screws (Oil Dipped).....	48 - 51 N•m (35 - 37 lb-ft.)
Connecting Rod Cap Screws (Oil Dipped).....	23 - 27 N•m (200 - 243 lb-in.)
Flywheel Cap Screws (Oil Dipped).....	89 - 93 N•m (65 - 68 lb-ft.)
Flywheel Adapter Cap Screws (Thread Lock).....	18 N•m (160 lb-in.)
Flywheel Fan Cap Screws.....	20 N•m (178 lb-in.)
Crankcase Cover Cap Screws.....	20 - 22 N•m (174 - 199 lb-in.)
Injector Leak-Off Fitting Nut.....	30 - 34 N•m (262 - 303 lb-in.)
Injector Holder.....	33 - 44 N•m (286 - 390 lb-in.)
Injector Nozzle.....	50 - 52 N•m (37 - 39 lb-ft.)
Injection Line Fitting Nut.....	30 - 34 N•m (262 - 303 lb-in.)
Glow Plug.....	15 - 19 N•m (131 - 173 lb-in.)
Muffler (Oil Dipped).....	18 - 19 N•m (157 - 173 lb-in.)

## REPAIR SPECIFICATIONS (Continued)

Standard Hardware:

- M6 . . . . . 8 - 9 N•m (70 - 86 lb-in.)
- M8 . . . . . 18 - 19 N•m (157 - 173 lb-in.)
- M10 . . . . . 36 - 43 N•m (313 - 381 lb-in.)

## SPECIAL TOOLS



• JT01682 Compression Gauge Assembly	• JT05719 or JT07270 Digital Tachometer
• D01110AA Adapter Set	• D05104ST Cooling System Pressure Pump
• JDG472 Adapter	• JT03017 Hose Assembly
• JDG692 Radiator Pressure Test Kit (Adapters)	• JT0334a Connector
• JT05577 Pressure Gauge 689 kPa (100 psi)	• JT07363 Universal Dial Indicator Kit (English) or: • D17526CI Dial Indicator (English) • D17527CI Dial Indicator (Metric) with • D17517CI Magnetic Base w/Flexible Arm or • D17525CI Magnetic Base w/Adjustable Arms
• Test Thermometer with Heating Unit and Glass Container	
• D01109AA Injector Tester	

## OTHER MATERIALS

- John Deere General Purpose Sealant . . . . . TY15934
- John Deere Ultra-Blue RTV Silicone Gasket Sealant . . . . . TY16135
- John Deere Never-Seez Lubricant . . . . . PT569 (Brush) or PT506 (Spray)
- John Deere Medium Strength Thread Lock Sealant . . . . . TY9370
- John Deere Primer-N-Cure Primer . . . . . TY16285

# COMPONENT LOCATION AND OPERATION

## ENGINE COMPONENT LOCATION

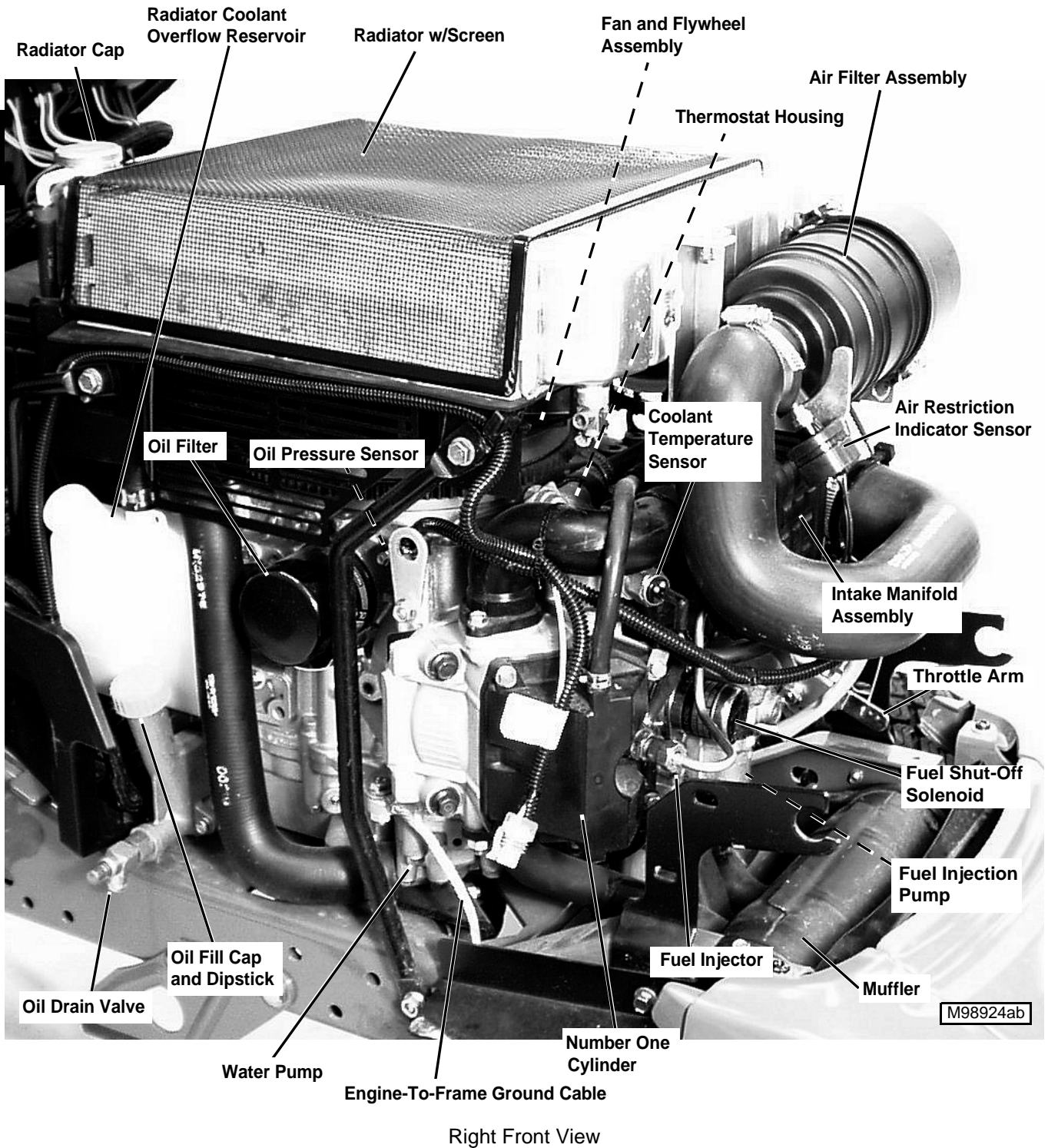



**Suggest:**

**If the above button click is invalid.**

**Please download this document**

**first, and then click the above link**

**to download the complete manual.**

**Thank you so much for reading**

## ENGINE COMPONENT LOCATION (Continued)

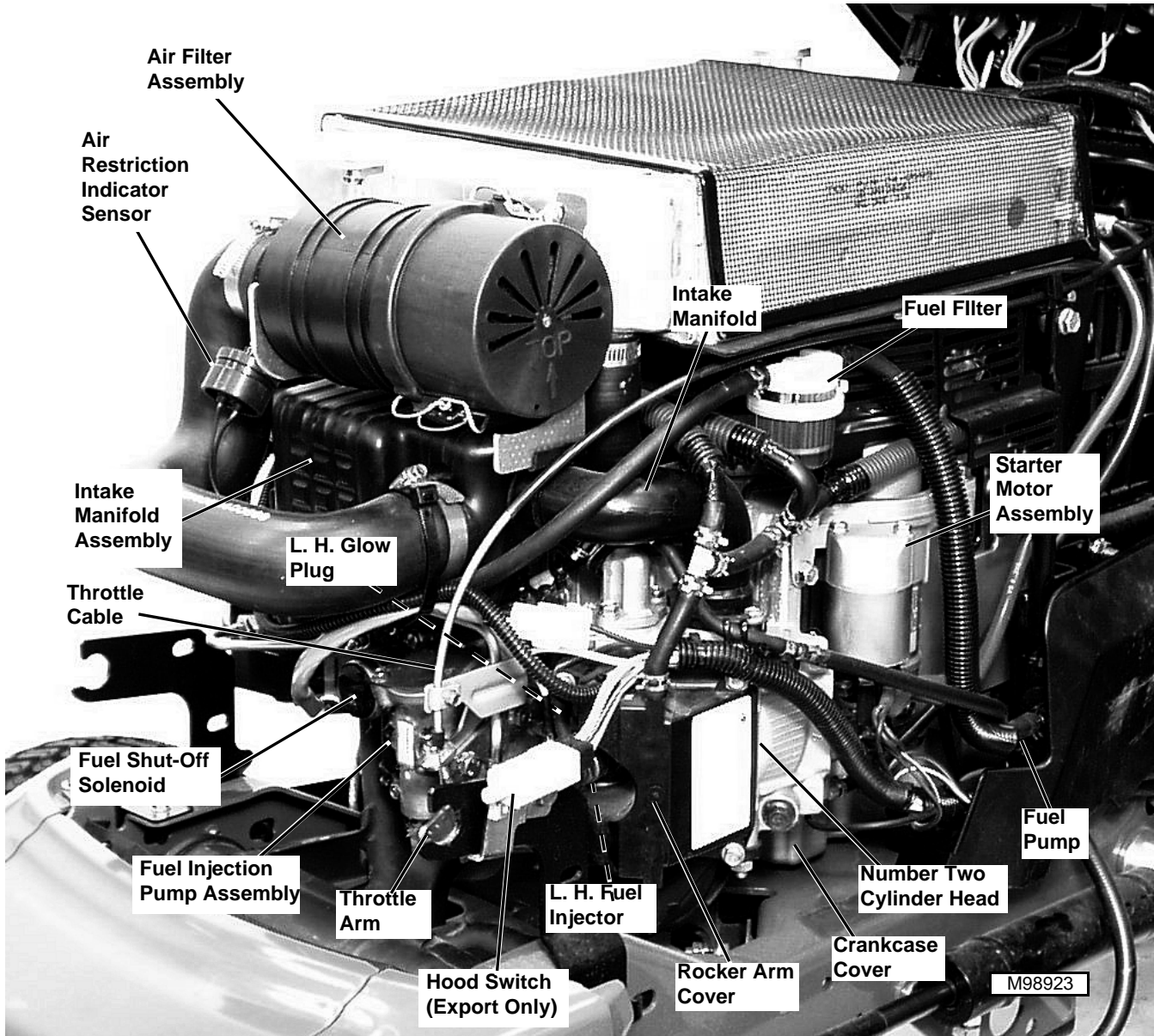

Left Front View

**NOTE:** On Export and late model Domestic tractors there is a hood switch connector:

*Export tractors—it connects to the hood switch on the front, left side hood mounting bracket and controls all electrical functions beyond the key switch and circuit board, excluding the headlight circuit. If the hood is open, no electrical power is supplied to the rest of the electrical components. Anytime the hood is opened or removed on Export tractors, the hood switch must be held closed to start the engine or test any electrical components or circuits.*

*Late Model Domestic tractors—it has a blue jumper wire installed into the connector instead of connecting to a hood switch; however, this blue jumper wire still controls all electrical functions beyond the key switch and circuit board, excluding the headlight circuit. Regardless if the hood is open or not, no electrical power is supplied to the rest of the electrical components if the blue jumper wire is missing, disconnected, corroded, or broken.*

*The Export hood switch or late model Domestic blue jumper wire should be checked before any electrical diagnostic procedures are performed.*

**<https://www.ebooklibonline.com>**

Hello dear friend!

Thank you very much for reading.

Enter the link into your browser.

The full manual is available for immediate download.

**<https://www.ebooklibonline.com>**