

JOHN DEERE
WORLDWIDE CONSTRUCTION AND
FORESTRY DIVISION

Skid Steer
260 and 270
TM1780 NOV03

TECHNICAL MANUAL

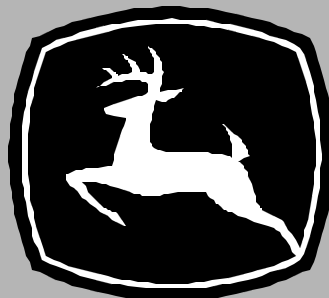

JOHN DEERE

This technical manual is written for an experienced technician and contains sections that are specifically for this product. It is a part of a total product support program.

The manual is organized so that all the information on a particular system is kept together. The order of grouping is as follows:

- Table of Contents
- Specifications
- Theory of Operation
- Troubleshooting Diagram
- Diagnostics
- Tests & Adjustments
- Repair

Note: Depending on the particular section or system being covered, not all of the above groups may be used.

Each section will be identified with a symbol rather than a number. The groups and pages within a section will be consecutively numbered.

All information, illustrations and specifications in this manual are based on the latest information available at the time of publication. The right is reserved to make changes at any time without notice.

We appreciate your input on this manual. To help, there are postage paid post cards included at the back. If you find any errors or want to comment on the layout of the manual please fill out one of the cards and mail it back to us.

Safety



Specifications and Information



Engine (Diesel)



Electrical



**Power Train
(Chain Case and Axles)**



**Power Train
(Hydrostatic)**



Steering



Brakes



Hydraulics



Miscellaneous

M

COPYRIGHT© 2003

JOHN DEERE

CONSTRUCTION AND FORESTRY DIVISION

Dubuque, Iowa

All rights reserved

Previous Editions

Copyright© 1999, 2000, 2001, 2002 Deere & Company



SAFETY

RECOGNIZE SAFETY INFORMATION

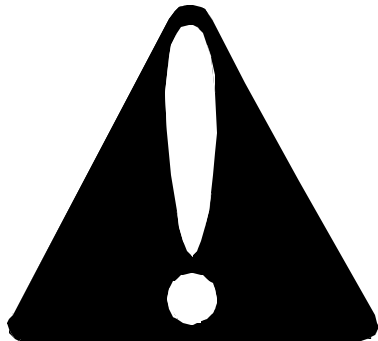

This is the safety-alert symbol. When you see this symbol on your machine or in this manual, be alert to the potential for personal injury.

Follow recommended precautions and safe servicing practices.

Understand Signal Words

A signal word—DANGER, WARNING, or CAUTION—is used with the safety-alert symbol. DANGER identifies the most serious hazards.

DANGER or WARNING safety signs are located near specific hazards. General precautions are listed on CAUTION safety signs. CAUTION also calls attention to safety messages in this manual.

REPLACE SAFETY SIGNS



Replace missing or damaged safety signs. See the machine operator's manual for correct safety sign placement.

HANDLE FLUIDS SAFELY—AVOID FIRES

Be Prepared For Emergencies

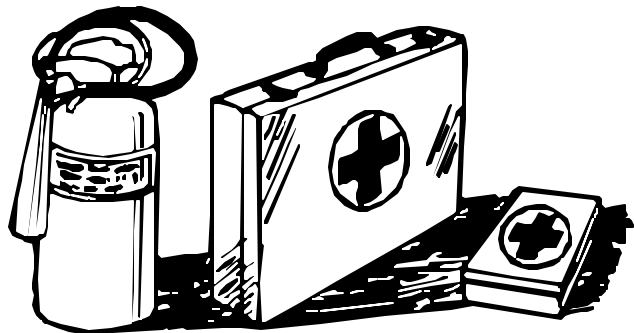

When you work around fuel, do not smoke or work near heaters or other fire hazards.

Store flammable fluids away from fire hazards. Do not incinerate or puncture pressurized containers.

Make sure machine is clean of trash, grease, and debris.

Do not store oily rags; they can ignite and burn spontaneously.

Be prepared if a fire starts.

Keep a first aid kit and fire extinguisher handy.

Keep emergency numbers for doctors, ambulance service, hospital, and fire department near your telephone.

<https://www.ebooklibonline.com>

Hello dear friend!

Thank you very much for reading.

Enter the link into your browser.

The full manual is available for immediate download.

<https://www.ebooklibonline.com>

USE CARE IN HANDLING AND SERVICING BATTERIES

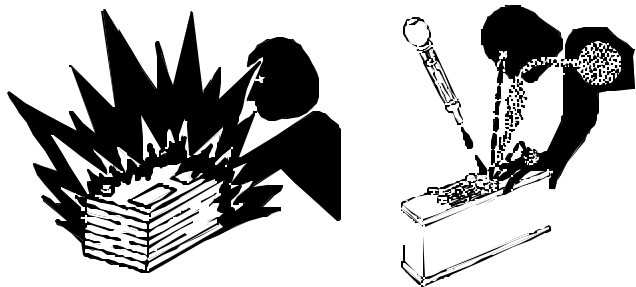

Prevent Battery Explosions

- Keep sparks, lighted matches, and open flame away from the top of battery. Battery gas can explode.
- Never check battery charge by placing a metal object across the posts. Use a volt-meter or hydrometer.
- Do not charge a frozen battery; it may explode. Warm battery to 16°C (60°F).

Prevent Acid Burns

- Sulfuric acid in battery electrolyte is poisonous. It is strong enough to burn skin, eat holes in clothing, and cause blindness if splashed into eyes.
- **Avoid acid burns by:**
 1. Filling batteries in a well-ventilated area.
 2. Wearing eye protection and rubber gloves.
 3. Avoiding breathing fumes when electrolyte is added.
 4. Avoiding spilling or dripping electrolyte.
 5. Using proper jump start procedure.
- **If you spill acid on yourself:**
 1. Flush your skin with water.
 2. Apply baking soda or lime to help neutralize the acid.
 3. Flush your eyes with water for 10—15 minutes.
 4. Get medical attention immediately.
- **If acid is swallowed:**
 1. Drink large amounts of water or milk.
 2. Then drink milk of magnesia, beaten eggs, or vegetable oil.
 3. Get medical attention immediately.

USE CARE AROUND HIGH-PRESSURE FLUID LINES

Avoid High-Pressure Fluids

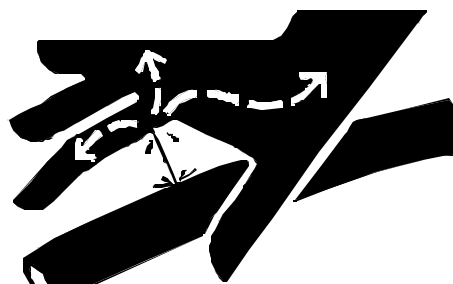

Escaping fluid under pressure can penetrate the skin causing serious injury.

Avoid injury from escaping fluid under pressure by stopping the engine and relieving pressure in the system before disconnecting or connecting hydraulic or other lines. Tighten all connections before applying pressure.

Search for leaks with a piece of cardboard. Protect hands and body from high pressure fluids.

If an accident occurs, see a doctor immediately. Any fluid injected into the skin must be surgically removed within a few hours or gangrene may result. Doctors unfamiliar with this type of injury should reference a knowledgeable medical source. Such information is available from Deere & Company Medical Department in Moline, Illinois, U.S.A., (1-800-822-8262 U.S.A. or Canada).



Avoid Heating Near Pressurized Fluid Lines



Flammable spray can be generated by heating near pressurized fluid lines, resulting in severe burns to yourself and bystanders. Do not heat by welding, soldering, or using a torch near pressurized fluid lines or other flammable materials. Pressurized lines can be accidentally cut when heat goes beyond the immediate flame area.

USE SAFE SERVICE PROCEDURES

Wear Protective Clothing

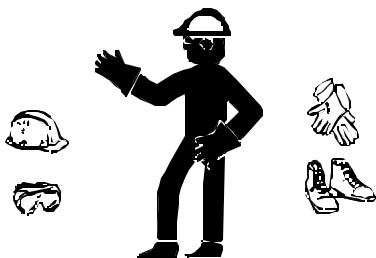

Wear close fitting clothing and safety equipment appropriate to the job.

Prolonged exposure to loud noise can cause impairment or loss of hearing. Wear a suitable hearing protective device such as earmuffs or earplugs to protect against objectionable or uncomfortable loud noises.

Operating equipment safely requires the full attention of the operator. Do not wear radio or music headphones while operating machine.

Service Machines Safely

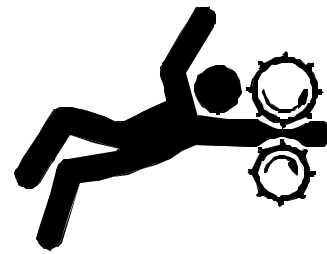

Tie long hair behind your head. Do not wear a necktie, scarf, loose clothing, or necklace when you work near machine tools or moving parts. If these items were to get caught, severe injury could result.

Remove rings and other jewelry to prevent electrical shorts and entanglement in moving parts.

Use Proper Tools

Use tools appropriate to the work. Makeshift tools and procedures can create safety hazards. Use power tools only to loosen threaded parts and fasteners. For loosening and tightening hardware, use the correct size tools. **DO NOT** use U.S. measurement tools on metric fasteners. Avoid bodily injury caused by slipping wrenches. Use only service parts meeting John Deere specifications.

Park Machine Safely

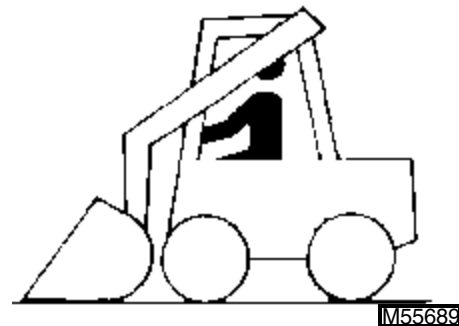

Before working on the machine:

1. Lower all equipment to the ground.
2. Relieve hydraulic pressure.
3. Stop the engine and remove the key.
4. Disconnect the battery ground strap.
5. Hang a "DO NOT OPERATE" tag in operator station.

Support Machine Properly and Use Proper Lifting Equipment

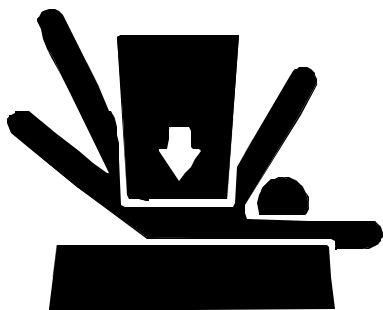

If you must work on a lifted machine or attachment, securely support the machine or attachment.

Do not support the machine on cinder blocks, hollow tiles, or props that may crumble under continuous load. Do not work under a machine that is supported solely by a jack. Follow recommended procedures in this manual.

Lifting heavy components incorrectly can cause severe injury or machine damage. Follow recommended procedure for removal and installation of components in the manual.

Work In Clean Area

Before starting a job:

1. Clean work area and machine.
2. Make sure you have all necessary tools to do your job.
3. Have the right parts on hand.
4. Read all instructions thoroughly; do not attempt shortcuts.

Using High Pressure Washers

Directing pressurized water at electronic/electrical components or connectors, bearings, hydraulic seals, fuel injection pumps or other sensitive parts and components may cause product malfunctions. Reduce pressure and spray component at a 45 to 90 degree angle.

Illuminate Work Area Safely

Illuminate your work area adequately but safely. Use a portable safety light for working inside or under the machine. Make sure the bulb is enclosed by a wire cage. The hot filament of an accidentally broken bulb can ignite spilled fuel or oil.

Work In Ventilated Area

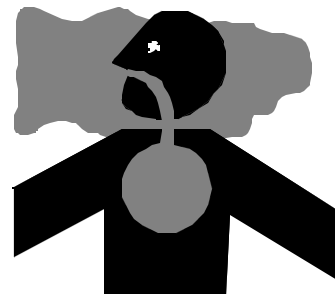

Engine exhaust fumes can cause sickness or death. If it is necessary to run an engine in an enclosed area, remove the exhaust fumes from the area with an exhaust duct system.

If you do not have an exhaust duct system, open the doors and get outside air into the area.

WARNING: California Proposition 65 Warning

Diesel engine exhaust and some of its constituents are known to the State of California to cause cancer, birth defects, and other reproductive harm.

Remove Paint Before Welding or Heating

Avoid potentially toxic fumes and dust. Hazardous fumes can be generated when paint is heated by welding, soldering, or using a torch. Do all work outside or in a well-ventilated area. Dispose of paint and solvent properly. Remove paint before welding or heating. If you sand or grind paint, avoid breathing the dust. Wear an approved respirator. If you use solvent or paint stripper, remove stripper with soap and water before welding. Remove solvent or paint stripper containers and other flammable material from area. Allow fumes to disperse at least 15 minutes before welding or heating.





SERVICE TIRES SAFELY

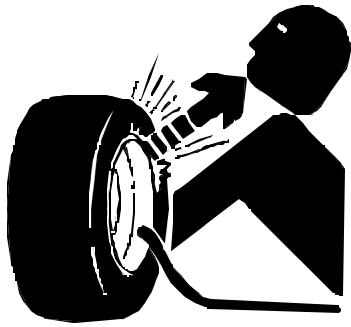

Explosive separation of a tire and rim parts can cause serious injury or death.

Do not attempt to mount a tire unless you have the proper equipment and experience to perform the job. Always maintain the correct tire pressure. Do not inflate the tires above the recommended pressure. Never weld or heat a wheel and tire assembly. The heat can cause an increase in air pressure resulting in a tire explosion. Welding can structurally weaken or deform the wheel.

When inflating tires, use a clip-on chuck and extension hose long enough to allow you to stand to one side and NOT in front of or over the tire assembly. Use a safety cage if available.

Check wheels for low pressure, cuts, bubbles, damaged rims or missing lug bolts and nuts.

SERVICE COOLING SYSTEM SAFELY

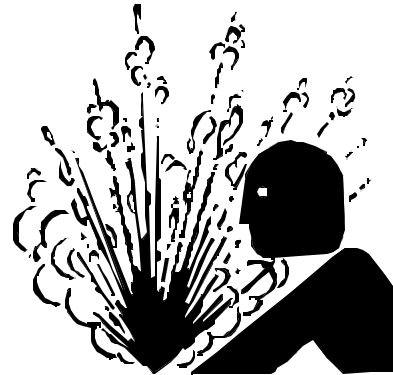

Explosive release of fluids from pressurized cooling system can cause serious burns.

Shut off machine. Only remove filler cap when cool enough to touch with bare hands. Slowly loosen cap to first stop to relieve pressure before removing completely.

HANDLE CHEMICAL PRODUCTS SAFELY

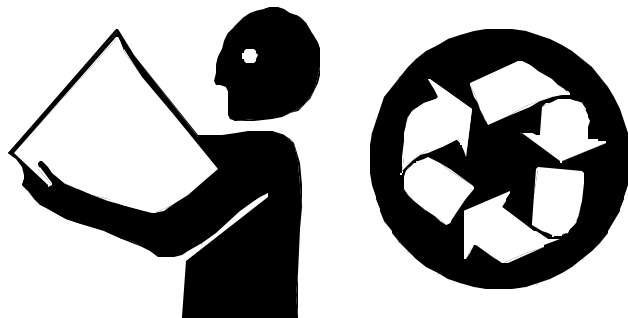

Direct exposure to hazardous chemicals can cause serious injury. Potentially hazardous chemicals used with John Deere equipment include such items as lubricants, coolants, paints, and adhesives.

A Material Safety Data Sheet (MSDS) provides specific details on chemical products: physical and health hazards, safety procedures, and emergency response techniques. Check the MSDS before you start any job using a hazardous chemical. That way you will know exactly what the risks are and how to do the job safely. Then follow procedures and recommended equipment.

Dispose of Waste Properly

Improperly disposing of waste can threaten the environment and ecology. Potentially harmful waste used with John Deere equipment include such items as oil, fuel, coolant, brake fluid, filters, and batteries. Use leakproof containers when draining fluids. Do not use food or beverage containers that may mislead someone into drinking from them. Do not pour waste onto the ground, down a drain, or into any water source. Inquire on the proper way to recycle or dispose of waste from your local environmental or recycling center, or from your John Deere dealer.

LIVE WITH SAFETY



Before returning machine to customer, make sure machine is functioning properly, especially the safety systems. Install all guards and shields.

CONTENTS

SPECIFICATIONS AND INFORMATION

	Page
SPECIFICATIONS	2
ENGINE	2
FUEL SYSTEM	2
ELECTRICAL SYSTEM	2
CAPACITIES	3
HYDRAULICS AND HYDROSTATICS	3
DIMENSIONS	4
TIRES (STANDARD)	4
RECOMMENDED LUBRICANTS	4
METRIC FASTENER TORQUE VALUES	5
METRIC FASTENER TORQUE VALUES—GRADE 7	6
INCH FASTENER TORQUE VALUES	7
O-RING SEAL SERVICE RECOMMENDATIONS	8
FACE SEAL FITTINGS WITH INCH STUD ENDS TORQUE	8
FACE SEAL FITTINGS WITH METRIC STUD ENDS TORQUE	9
O-RING FACE SEAL FITTINGS	10
O-RING BOSS FITTINGS	10
DIESEL FUEL SPECIFICATIONS	11
LUBRICITY	11
STORAGE	11
ENGINE OIL SPECIFICATIONS	12
4-CYCLE DIESEL ENGINE OIL—NORTH AMERICA	12
BREAK-IN DIESEL ENGINE OIL—NORTH AMERICA	13
HYDROSTATIC TRANSMISSION AND HYDRAULIC OIL—NORTH AMERICA	13
CHAIN CASE OIL SPECIFICATIONS	14
CHAIN CASE OIL—NORTH AMERICA	14
GENERAL APPLICATION GREASE SPECIFICATIONS	15
GREASE—NORTH AMERICA	15
COOLANT SPECIFICATIONS	15
DIESEL AND GASOLINE ENGINE COOLANT—NORTH AMERICA	15
SUPPLEMENTAL COOLANT ADDITIVES	16
DIESEL AND GASOLINE ENGINE COOLANT DRAIN INTERVAL—NORTH AMERICA	16
SERIAL NUMBER LOCATION	17
SKID STEER PRODUCT IDENTIFICATION NUMBER	17
ENGINE SERIAL NUMBER	17



SPECIFICATIONS

ENGINE

Make John Deere
 Type..... Diesel
 Engine Model Number:
 Model 260 3029T
 Model 270 4045D
 Net Horsepower at Rated Engine RPM (2400 RPM):
 Model 260 51.5 kW (69 hp)
 Model 270 57.5 kW (77 hp)
 Cylinders:
 Model 260 3
 Model 270 4
 Bore..... 106 mm (4.17 in.)
 Stroke:
 Model 260 110 mm (4.33 in.)
 Model 270 127 mm (5.00 in.)
 Displacement:
 Model 260 2.9 L (179 cu in.)
 Model 270 4.5 L (276 cu in.)
 Compression Ratio:
 Model 260 17.8:1
 Model 270 17.6:1
 Engine Rated RPM 2400
 Lubrication..... Full pressure
 Oil Filter..... Full flow (replaceable)
 Air Cleaner Dry paper with primary and secondary elements
 Cooling System..... Liquid-cooled

FUEL SYSTEM

Fuel Diesel
 Fuel Filter In-line replaceable filter
 Fuel Pump..... Electric
 Fuel Delivery Rotary injection

ELECTRICAL SYSTEM

Type..... 12-volt, electric start
 Charging System..... Alternator, 55 amp
 Battery..... 950 CCA (cold cranking amps)

CAPACITIES

Fuel Tank	75.7 L (20.0 gal)
Hydraulic Reservoir	26.5 L (7 gal)
Hydraulic System	34.1 L (9 gal)
Cooling System:	
Model 260	10.6 L (11 qt)
Model 270	13.4 L (14 qt)
Engine Oil (with Filter):	
Model 260	7.4L (8.0 qt)
Model 270	12.0 L (12.7 qt)
Chain Case (per Side)	
Model 260 (S.N. —369999)	11.5 L (3.05 gal)
Model 260 (S.N. 460001—)	18.9 L (5.0 gal)
Model 270 (S.N. —379999)	11.5 L (3.05 gal)
Model 270 (S.N. 470001—)	18.9 L (5.0 gal)



HYDRAULICS AND HYDROSTATICS

Hydrostatic Pumps:	
Type	Tandem variable displacement piston pump
Displacement (Max)	49.1 cm ³ (3 in ³) per revolution
Hydrostatic Motor Type	
Single Speed	GEROLER [®] fixed displacement 45 series
2-speed	Poclain Hydraulics MS series
Hydraulic/Charge Pump:	
Type	High pressure gear pump
Flow:	
(Standard):	
260 (with 26000 series pump)	64.3 L/min (17 gpm) (minimum)
270 (and 260 with 27000 SERIES pump)	71.8 L/min (19 gpm) (minimum)
(High-Flow Option):	
260 (with 26000 series pump)	107.5 L/min (28.4 gpm) (minimum)
270 (and 260 with 27000 SERIES pump)	121.5 L/min (32.1 gpm) (minimum)
Hydrostatic System Relief Pressure	34 474 kPa (5000 psi)
Charge Circuit Pressure	
Single Speed	1379—1551 kPa (200—225 psi)
2-Speed	1928—2208 kPa (300—340 psi)
Hydraulic Control Valve3-spool open center
Filter	Spin-on canister
Hydraulic System Relief Pressure	21 374 ± 1034 kPa (3100 ± 150 psi)
Boom Circuit Relief Pressure	23 442 kPa (3400 psi)
Bucket Circuit Relief Pressure	N/A
<i>Note: Bucket relief valve should have been removed in Safety PIP 99KV004 or 00KV007</i>	
Skid Steer SAE Rated Operating Capacities:	
Model 260	998 kg (2200 lb)
Model 270	1 180 kg (2600 lb)
Maximum Ground Speed:	
Single Speed	10.6 km/h (6.6 mph)
2-Speed	19.3 km/h (12.0 mph)
Boom Breakout Force	2132 kg (4700 lb)
Bucket Breakout Force	3039 kg (6700 lb)

GEROLER is a registered trademark of Eaton Corporation.

DIMENSIONS

(See note below.)

Overall Operating Height	4000 mm (157.5 in.)
Height to ROPS	2106 mm (82.9 in.)
Height to Hinge Pin	3226 mm (127.0 in.)
Overall Width (less Bucket)	1953 mm (76.9 in.)
Overall Width (with Bucket)	1981 mm (78.0 in.)
Overall Length (less Bucket)	2921 mm (115.0 in.)
Overall Length (with Bucket)	3504 mm (138.0 in.)
Wheelbase	1227 mm (48.3 in.)
Operating Weight:	
Model 260	3787 kg (8350 lb)
Model 270	3890 kg (8575 lb)
Ground Clearance	280 mm (11.0 in.)
Dump Height	2591 mm (102.0 in.)
Dump Reach	813 mm (32.0 in.)
Dump Angle	45 degrees
Bucket Rollback	35 degrees
Angle of Departure	26 degrees

NOTE: Standard tires (14.00 x 17.50) and 1981 mm (78 in.) dirt bucket used in determining dimensions.

TIRES (STANDARD)

Size	14 x 17.5
----------------	-----------

RECOMMENDED LUBRICANTS

Engine Oil	John Deere TORQ-GARD SUPREME® John Deere PLUS-50®
(See ENGINE OIL in the DIESEL ENGINE section for cold weather oil)	
Engine Coolant	John Deere COOL-GARD™ John Deere ANTIFREEZE/SUMMER COOLANT
Hydraulic Oil and Hydrostatic Oil	John Deere HY-GARD® John Deere Low Viscosity HY-GARD (cold weather operation)
Chain Case Oil	John Deere HY-GARD John Deere Low Viscosity HY-GARD (cold weather operation)
	John Deere TORQ-GARD SUPREME John Deere PLUS-50
Grease	John Deere MOLY HIGH TEMPERATURE EP GREASE John Deere NON-CLAY HIGH TEMPERATURE EP GREASE

TORQ-GARD SUPREME, PLUS-50, and HY-GARD are registered trademarks of Deere & Company.
COOL-GARD is a trademark of Deere & Company.

REPAIR

**FOR ENGINE REPAIR USE
CTM125—260 OR CTM104 AND
CTM207—270**

**FOR STARTER AND ALTERNATOR
REPAIR USE CTM77**

ENGINE REPAIR STAND

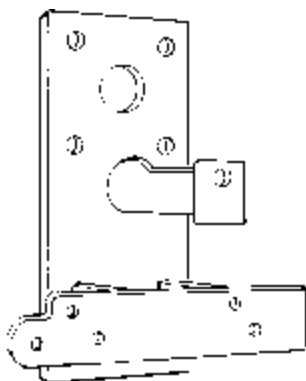

D05225ST

D05225ST Repair Stand Adapter

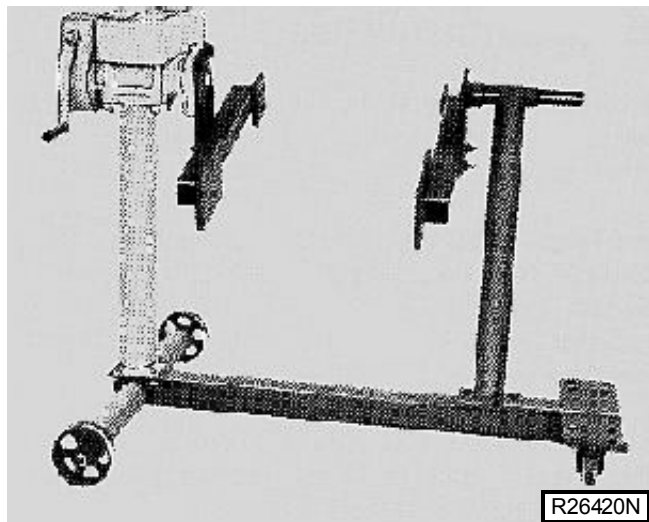

R26420N

D01003AA Engine Repair Stand

To facilitate engine repair, the D01003AA repair stand can be used in conjunction with D05225ST adapter.

**CAUTION**

This repair stand should be used only by qualified service technicians familiar with this equipment.

To maintain shear strength specifications, alloy steel SAE Grade 8 or higher cap screws must be used to mount adapters on engine.

For full thread engagement, be certain that tapped holes in adapters and engine blocks are clean and not damaged. A thread length engagement equal to 1-1/2 screw diameters minimum is required to maintain strength requirements.

To avoid structural damage or personal injury, do not exceed the maximum weight capacity. When engine weight is more than 450 kg (992 lb), it is recommended to use additional support.

To prevent possible personal injury due to engine slippage, recheck to make sure engine is solidly mounted before releasing support from engine lifting device.

Never permit any part of the body to be positioned under a load being lifted or suspended. Accidental slippage may result in personal injury.

**MOUNT ENGINE ON REPAIR
STAND—260****CAUTION**

DO NOT remove the overhead lifting equipment until the engine is securely mounted onto the repair stand and all mounting hardware is tightened to specified torque.

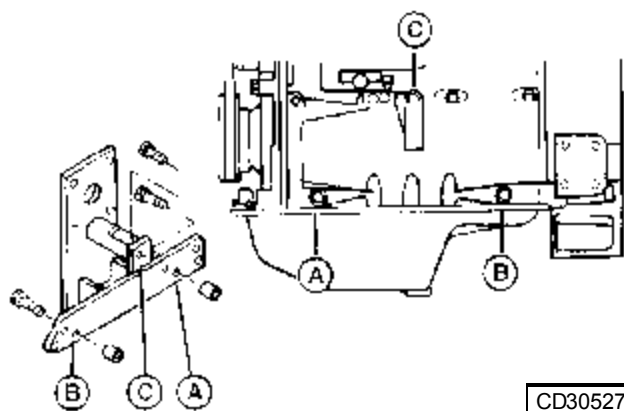

CD30527

1. Use a 73 mm spacer at hole (A) and a 79 mm spacer at hole (B).
2. Mount engine to adapter using the cap screws listed below at the hole locations as shown:
 - Holes A and B, 114 mm (9/16-12 x 4-1/2 in.)
 - Hole C, 38 mm (9/16-12 x 1-1/12 in.)
3. Drain all engine oil and coolant.

IMPORTANT: Hydraulic lock occurs when trapped oil in the oil filter housing drains through the turbocharger, the exhaust and intake manifolds, and then into the cylinder head. After starting the engine, the trapped oil in the manifold and head is released into the cylinders, filling them with oil, causing hydraulic lock and severe engine damage.

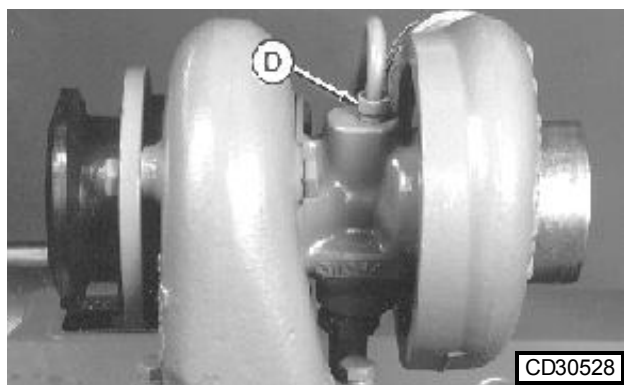

CD30528

4. Disconnect oil inlet line at turbocharger (D) to prevent hydraulic lock.

MOUNT ENGINE ON REPAIR STAND—270

CAUTION

DO NOT remove the overhead lifting equipment until the engine is securely mounted onto the repair stand and all mounting hardware is tightened to specified torque.

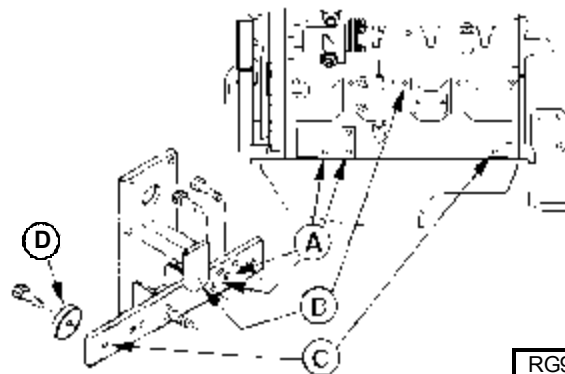

RG9058

NOTE: Engine adapter, cap screws, and spacer are from JT07268 Engine Adapter Kit.

Mount the engine to 62835 Engine Adapter as described below.

NOTE: No. 221668 Spacer (D) is used on the outside of the engine adapter.

- Hole A—(2) No. 214490 (M12 x 1.75 x 35 mm)
- Hole B—(1) No. 221664 (M14 x 2.00 x 35 mm)
- Hole C—(1) No. 221665 (M14 x 2.00 x 60 mm) with No. 221668 Spacer

NOTE: Four threaded holes in engine mounting adapter are for storing mounting hardware.

Specifications:

Engine Repair Stand

- M12 Cap Screw Torque 140 N•m (105 lb-ft)
M14 Cap Screw Torque 225 N•m (165 lb-ft)

ENGINE REMOVAL/INSTALLATION

NOTE: 270 shown throughout. 260 procedures are similar except where noted.

NOTE: Engine weigh approximately:

260 363 kg (800 lb)

270 454 kg (1000 lb)

Be sure Engine Repair Stand and Engine Hoist have adequate capacity.

Equipment:

- Engine Hoist
- JDG23 Lifting Sling (270)
- JDG394 Lifting Sling(260)
- JT01748 Lifting Brackets
- JDG19 Lifting Bracket
- D01003AA Engine Repair Stand
- D05225ST Engine Repair Stand Adapter

Removal:

1. Remove any attachments.
2. Park skid steer safely. Place blocks in front of and behind tires.
3. Raise boom to the fully raised position and engage boom locks. Lower boom onto boom locks.
4. Disconnect battery negative (-) cable.
5. Raise ROPS and ensure that it is safely in the locked position. (See RAISING ROPS [ROLL OVER PROTECTION STRUCTURE] in the MISCELLANEOUS section.)
6. Remove cover plates. (See COVER PLATE REMOVAL/INSTALLATION in the MISCELLANEOUS section.)
7. Remove side engine panels.

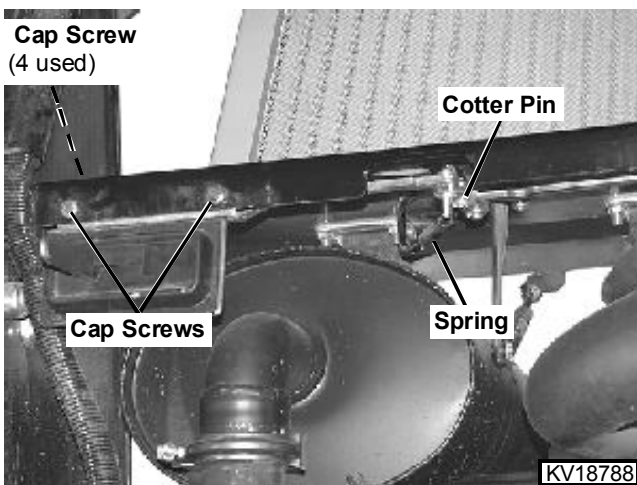

8. Remove cotter pin, spring, and two cap screws and nuts holding boom lock linkage to support plate.

9. Remove two cap screws and nuts from each side of support and remove support with top engine access panel.

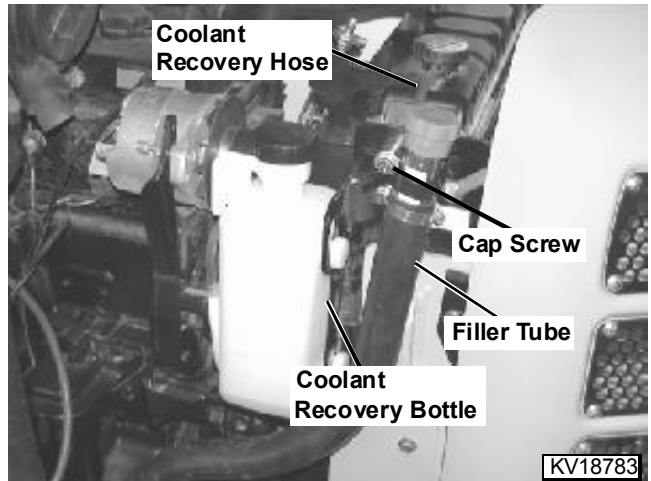

10. Disconnect coolant recovery hose from radiator filler neck and remove hose and coolant recovery bottle.
11. Remove filler tube-to-radiator support cap screw. Position tube out of the way.

⚠ CAUTION

AVOID INJURY. Explosive release of fluids from pressurized cooling system can cause serious burns.

Shut off engine. Remove filler cap only when cool enough to touch with bare hands. Slowly loosen cap to first stop to relieve pressure before removing completely.

NOTE: Approximate cooling system capacity is:
 260—10.6 L (11 qt)
 270—13.4 L (14 qt)

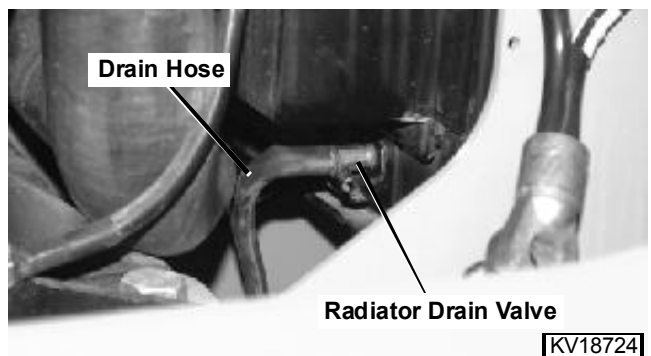

12. Loosen radiator cap to first stop to relieve pressure. Route radiator drain hose out access panel on left side of frame. Open radiator drain valve and drain coolant through drain hose into proper container.

13. Remove cab heater hoses (if equipped).

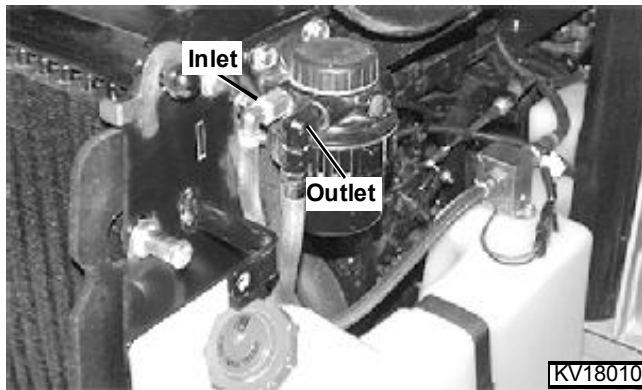

NOTE: Close all openings using caps or plugs to prevent contamination of fuel system.

14. Disconnect inlet line from fuel filter. Remove filter base and attach to engine using wire or plastic tie.

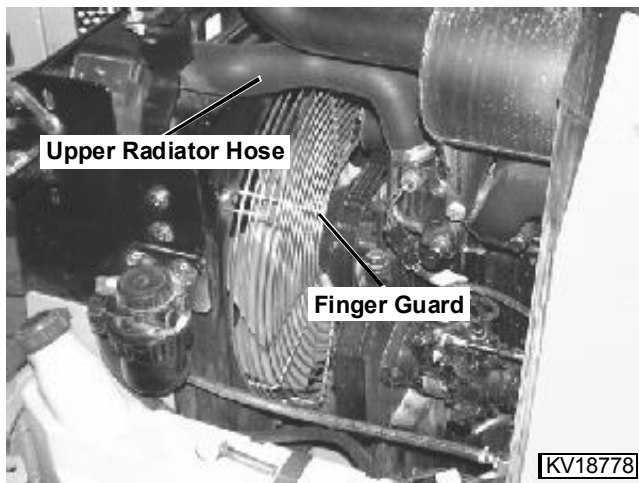

15. Disconnect upper radiator hose from radiator and remove finger guard.

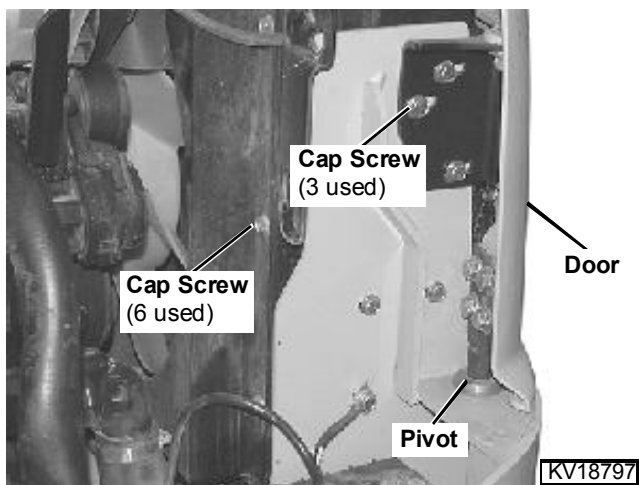

16. Remove six cap screws from fan shroud. Move shroud toward engine away from radiator.

17. Disconnect lower radiator hose from radiator.

18. Remove three cap screws and shims. Lift door up and out of pivot.

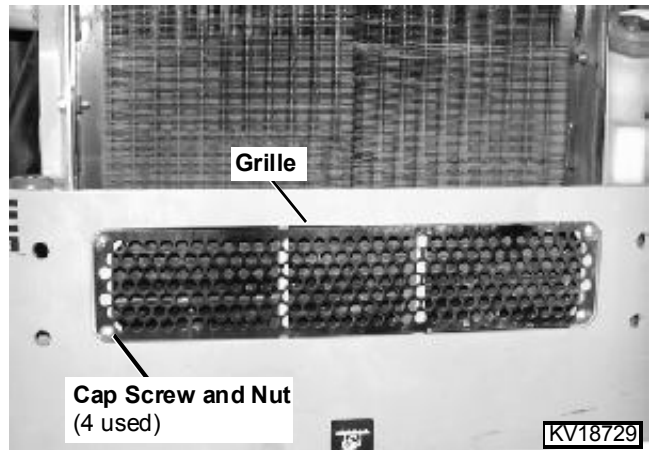

19. Remove four cap screws, nuts, and lower grille.

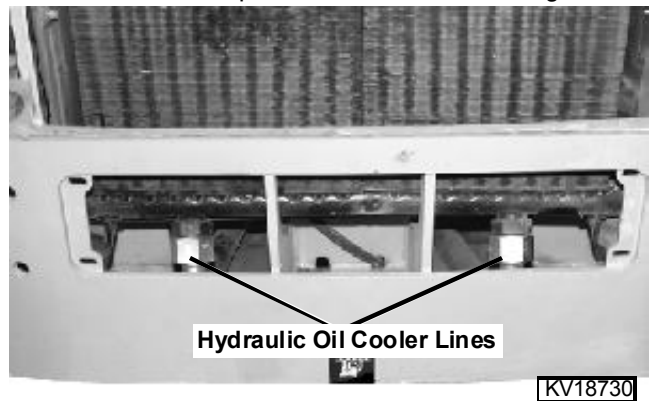

NOTE: Use caps and plugs to close all openings to avoid hydraulic system contamination.

20. Disconnect two hydraulic lines to oil cooler.

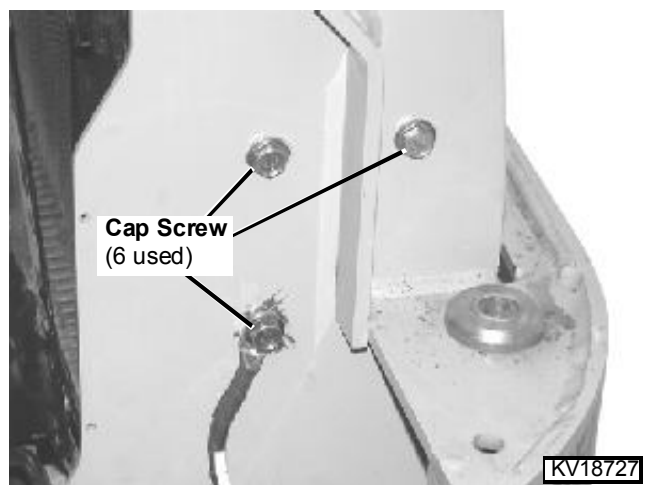

21. Remove three cap screws from each side of radiator support.

22. Remove radiator and oil cooler assembly using a lifting strap and hoist.

23. Machines equipped with air conditioning: remove compressor from its mounting bracket. Slide out

condenser and hang compressor and condenser on right side of machine.

24. Remove compressor mounting bracket.

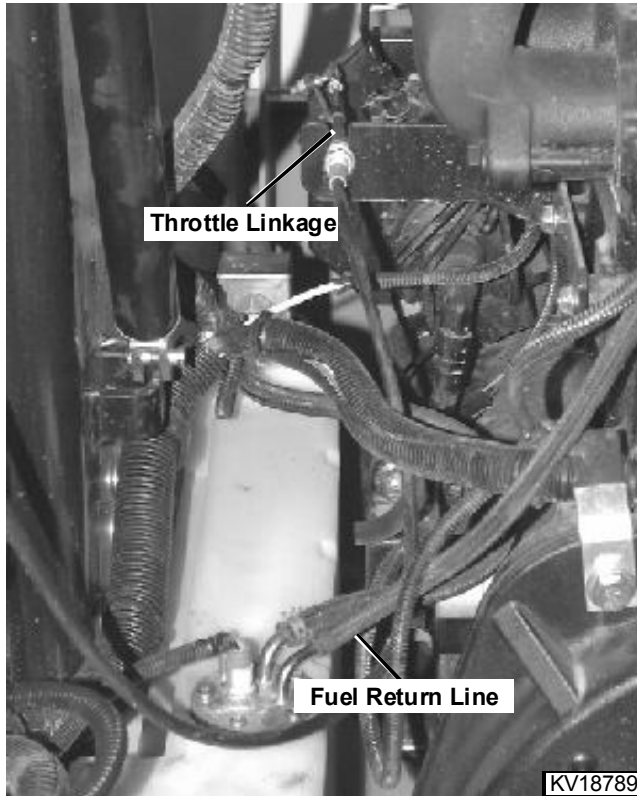

KV18789

25. Disconnect throttle linkage from injection pump and bracket.

26. Disconnect fuel return line.

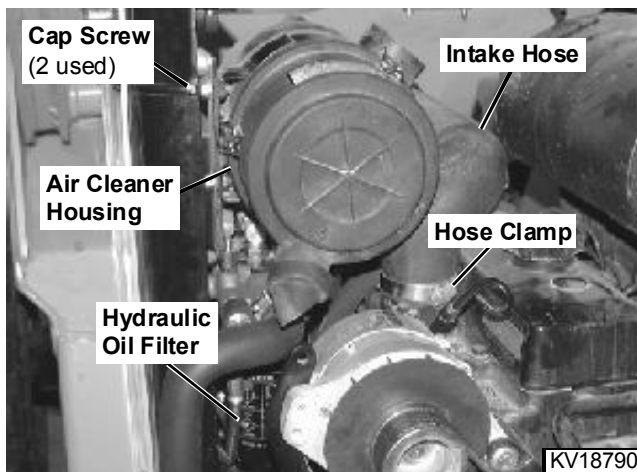

KV18790

NOTE: Tag or label all wires and connectors to aid installation.

27. Disconnect air filter restriction switch connector. Remove two cap screws, hose clamp, air cleaner housing, and intake hose.

28. Remove muffler.

29. Disconnect all wiring leads or connectors from starting motor, starter solenoid, alternator, manifold preheater, oil pressure sending unit, coolant temperature sending unit, and fuel shut-off solenoid.

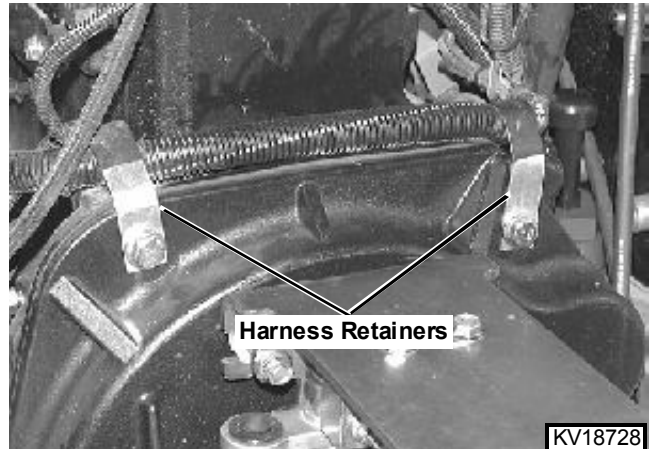

KV18728

30. Bend harness retainers away from engine and remove harness.

31. Disconnect backup alarm (if equipped).

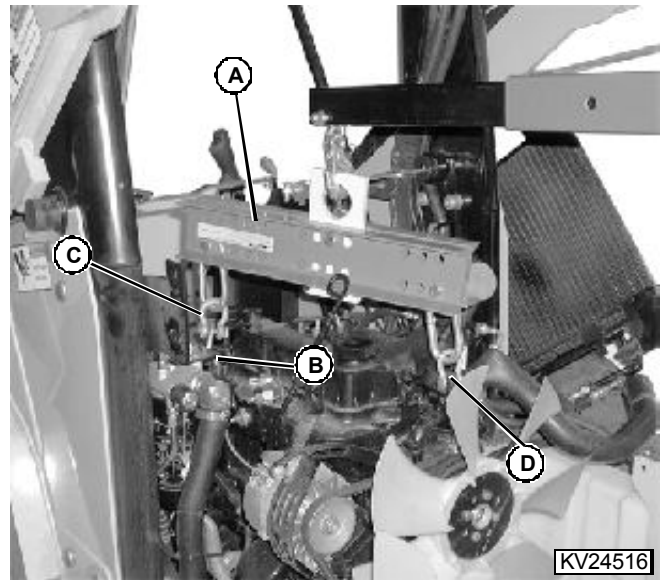

KV24516

260 Models

32. For 260 models attach JDG394 lifting sling (A) to a suitable hoist. Attach JDG19 lifting bracket (B) to rear of cylinder head and JT01748 Lifting bracket (D) to front of cylinder head.

33. Attach JDG19 to lifting sling using a clevis (C). Raise hoist slightly to tension lifting brackets.

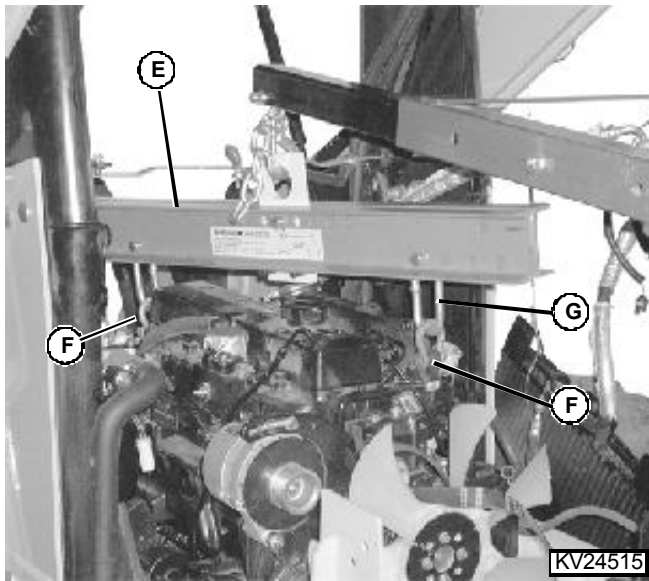

270 Models

- 34. For 270 models attach JDG23 lifting sling (E) to a suitable hoist. Attach JT01748 lifting brackets (F) to the front and rear of cylinder head.
- 35. Attach lifting sling to lifting brackets using closed rings (G) from JDG394 lifting sling.
- 36. Raise hoist slightly to tension lifting brackets.

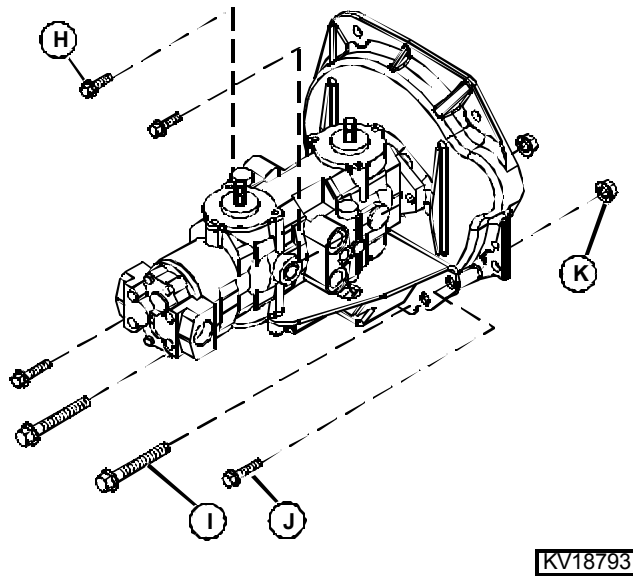

- 37. Remove pump flange mounting cap screws (H).
- 38. Remove cap screws and nuts (I and K) and cap screws (J) from front engine mount/pump mounting plate.

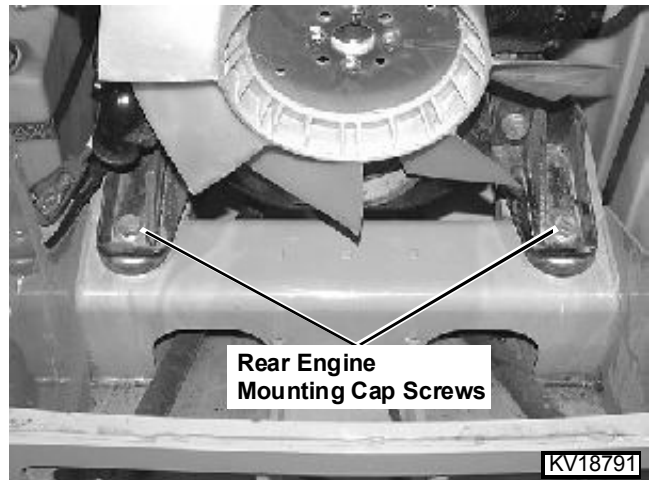

- 39. Remove rear engine mounting cap screws.

NOTE: Make sure all electrical wiring, lines, and hoses are disconnected from engine before removal.

- 40. Lift engine slightly and move engine rearward to slide pump coupler out of flywheel housing.
- 41. Remove engine.
- 42. Lower engine onto floor and support with blocks.
- 43. Remove remaining flywheel cover cap screws. Remove flywheel cover.

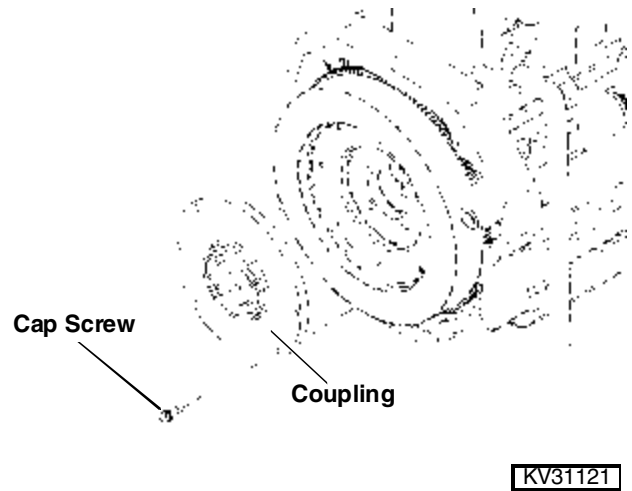

- 44. Remove eight coupling-to-flywheel cap screws. Remove coupling.
- 45. Install engine on repair stand. (See MOUNT ENGINE ON REPAIR STAND—260 or MOUNT ENGINE ON REPAIR STAND—270.)

Installation:

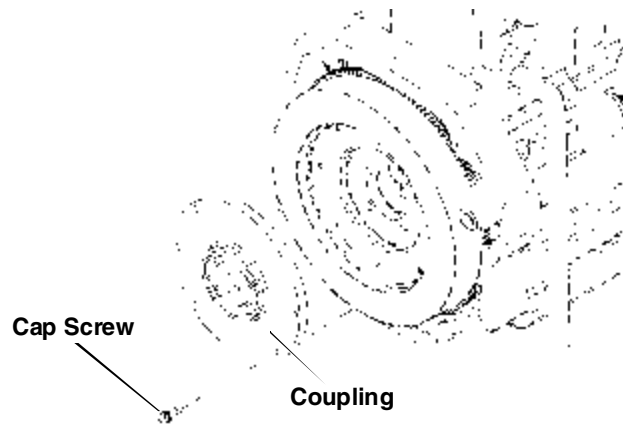

KV31121

1. Place coupling on flywheel and install eight coupling-to-flywheel cap screws. Tighten to **39 N•m (29 lb-ft)**.
2. Attach engine to hoist and lower into position.

IMPORTANT: Before installing engine, make sure all electrical wiring, lines, and hoses are moved away from engine.

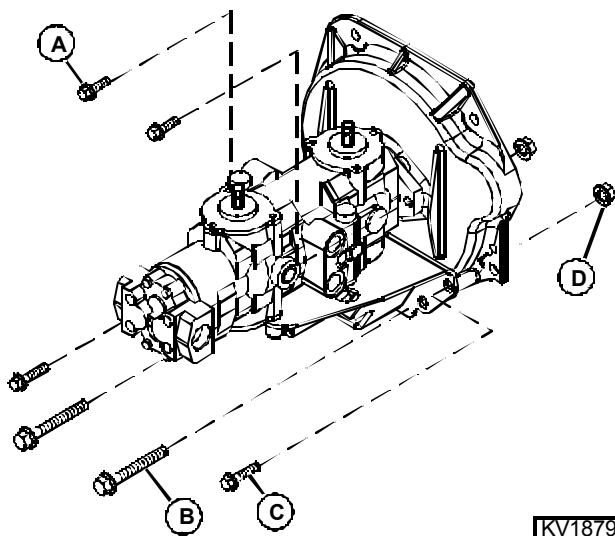

KV18793

3. Move engine into place so coupler on pumps will slide into coupling on flywheel. It may be necessary to loosen front engine mount and rotate engine to obtain proper alignment. If front mount is loosened tighten to **305 N•m (225 lb-ft)**.
4. Install cap screws (B and C), and nuts (D). Tighten cap screws (B) with nuts (D) to **305 N•m (255 lb-ft)**. Tighten remaining cap screws (C) to **140 N•m (105 lb-ft)**.

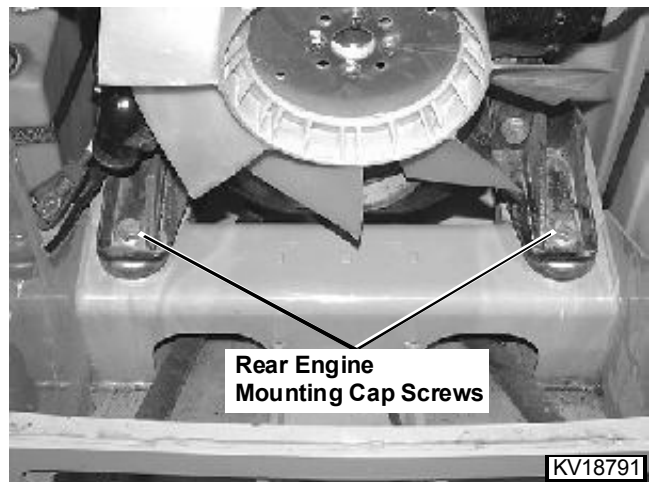

IMPORTANT: If bushings have flat sides, flat side should be parallel to machine sides. **DO NOT ROTATE** while tightening mounting hardware.

5. Install lower grommets, lower washers, nuts, and bolts of rear engine mounting hardware. Tighten to **305 N•m (225 lb-ft)**.

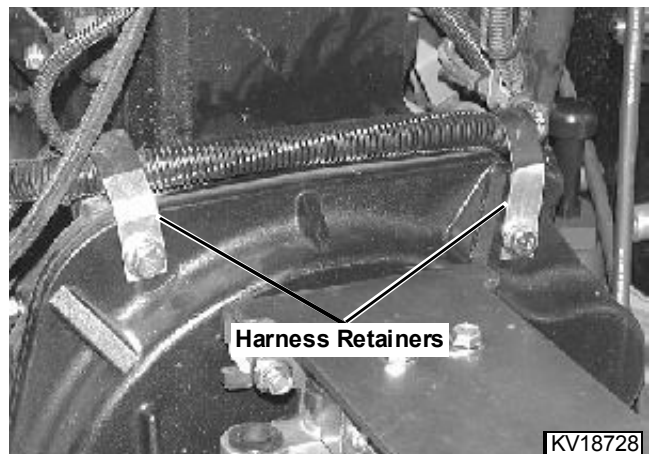

6. Install wiring harness into retainers and bend retainers back toward engine.
7. Connect all wiring leads as tagged from removal to starting motor, starter solenoid, alternator, manifold pre heater, oil pressure sending unit, coolant temperature sending unit, and fuel shut-off solenoid.

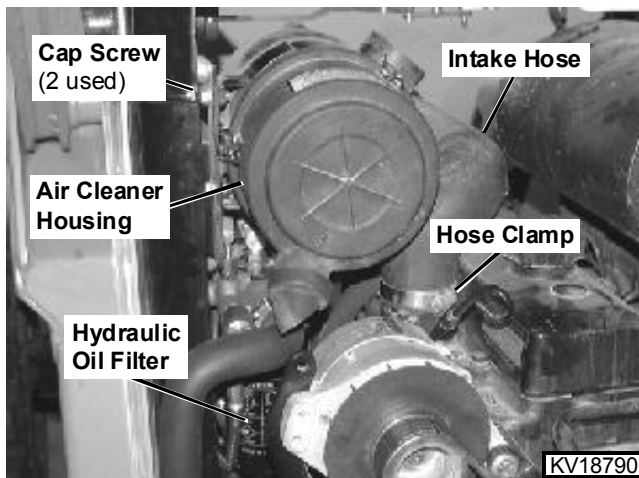

8. Install air cleaner/intake hose assembly to mounting bracket. Connect air filter restriction switch connector.

9. Install muffler.

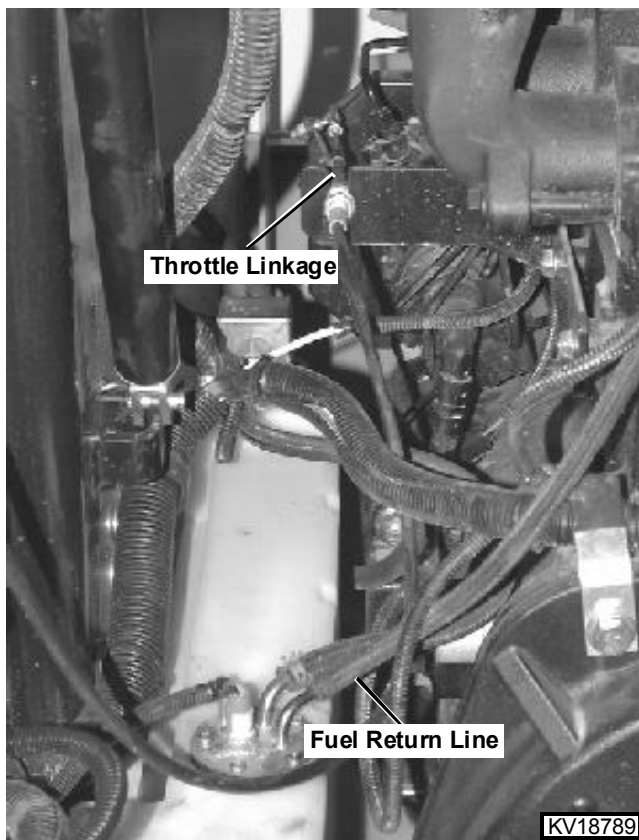

10. Connect fuel return line.

11. Connect throttle linkage to bracket and injection pump.

12. Install air conditioning compressor mounting bracket if equipped.

13. Install compressor if equipped.

NOTE: Notches on fan shroud lip fit around hose connections on radiator.

14. Place fan shroud over fan and set condenser if equipped, against shroud.

15. Install radiator and oil cooler assembly using lifting strap and hoist.

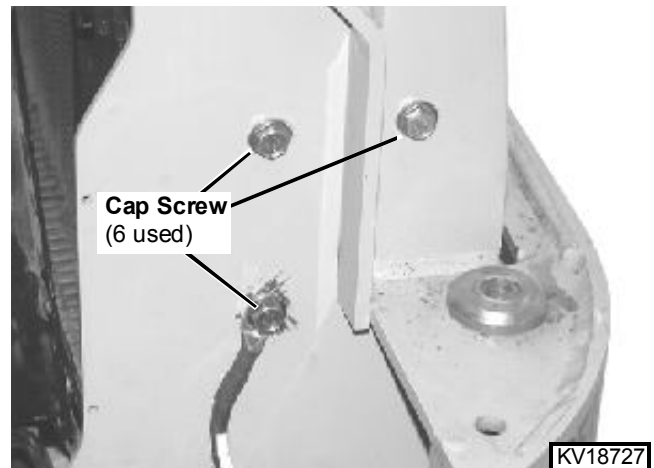

NOTE: Make sure ground cable is installed under cap screw.

16. Apply thread lock and sealer (medium strength) to threads of mounting cap screws. Install three cap screws on each side of radiator support. Tighten to **29 N•m (21 lb-ft)**.

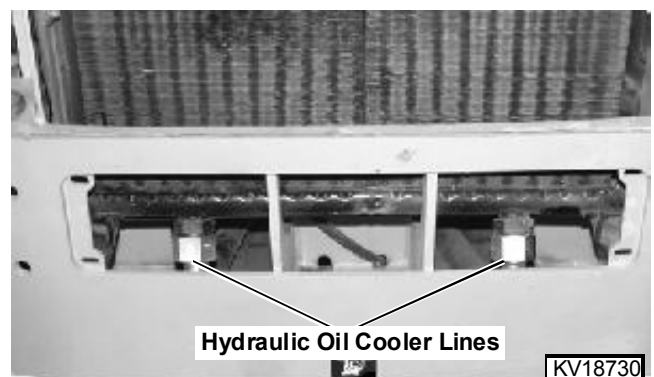

17. Using new O-rings, connect two hydraulic lines to oil cooler.

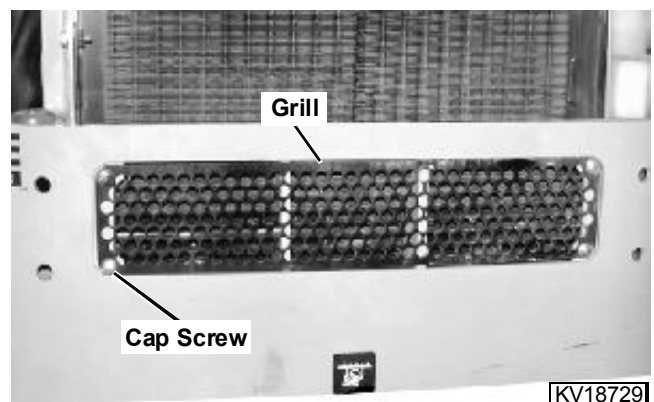

18. Install lower grill using four cap screws and nuts.



Suggest:

If the above button click is invalid.

Please download this document

first, and then click the above link

to download the complete manual.

Thank you so much for reading

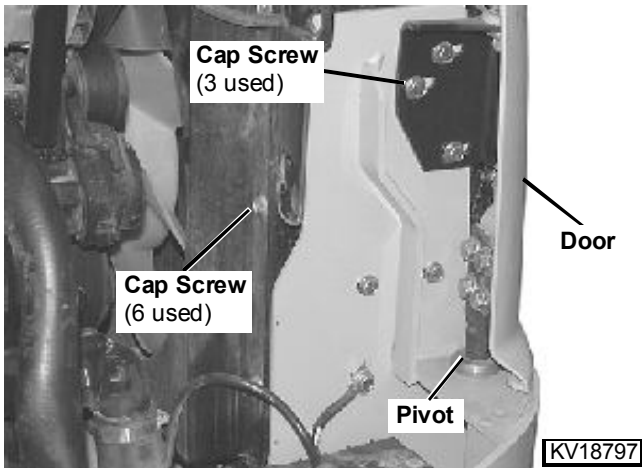

19. Install door into pivot. Secure and adjust using cap screws and shims.
20. Connect lower radiator hose to radiator.
21. Install fan shroud and condenser, if equipped, to radiator using six cap screws.
22. Check fan tip clearance. Fan tip should have clearance of 10 ± 1.0 mm (0.40 ± 0.04 in.) to fan shroud cutout.

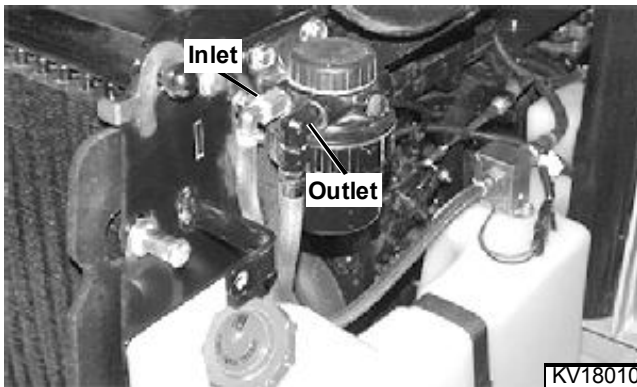

23. Install fuel filter base with filter. Connect inlet line to filter base.
24. Install hydraulic oil reservoir drain plug and tighten securely.
25. Install bottom engine access cover.

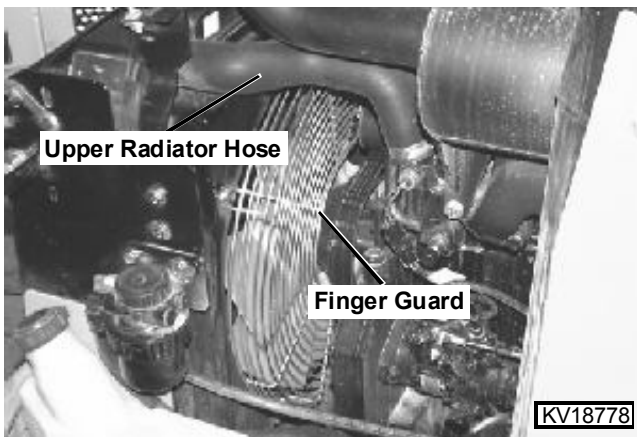

26. Install finger guard with cap screws. Tighten to $26 \text{ N}\cdot\text{m}$ ($19 \text{ lb}\cdot\text{ft}$).

27. Connect upper radiator hose.
28. Connect cab heater hoses (if equipped).

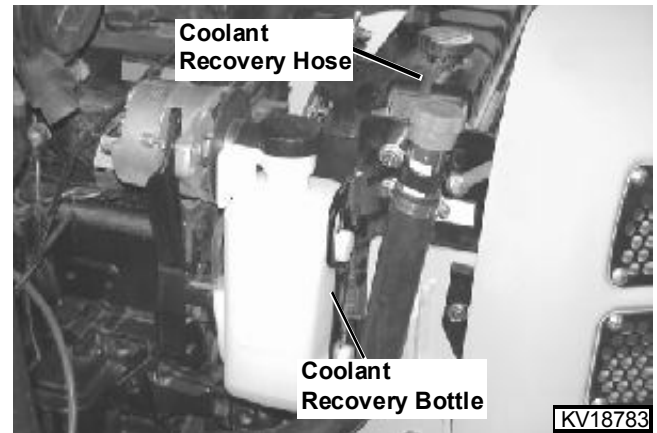

29. Install coolant recovery hose to radiator filler neck and install coolant recovery bottle to radiator support.

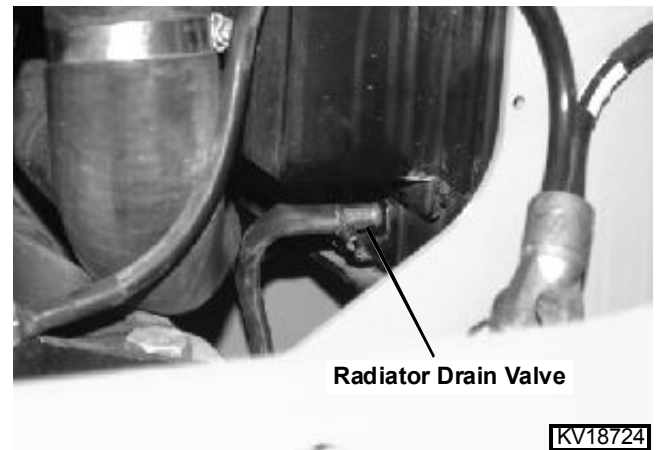

NOTE: Approximate cooling system capacity is:
260—10.6 L (11 qt)
270—13.4 L (14 qt)

30. Close radiator drain valve and fill radiator with proper coolant to bottom of filler neck.
31. Install and tighten hydraulic oil filler hose cap screw.

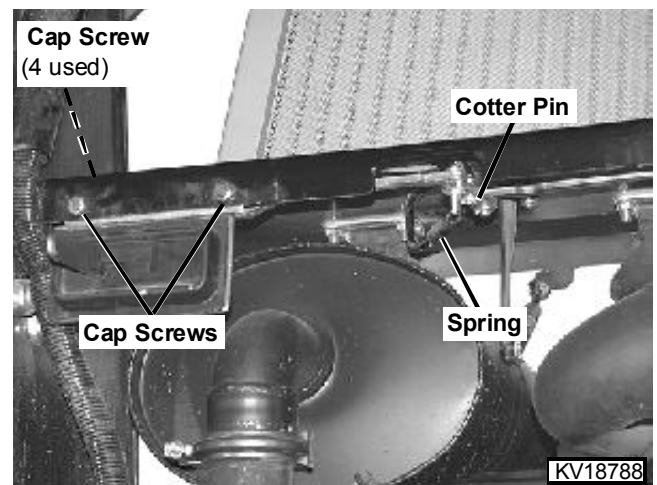

<https://www.ebooklibonline.com>

Hello dear friend!

Thank you very much for reading.

Enter the link into your browser.

The full manual is available for immediate download.

<https://www.ebooklibonline.com>