

**240, 245, 260,  
265, 285, and 320  
Lawn and Garden Tractors**

**TECHNICAL  
MANUAL**

**John Deere  
Worldwide Commercial and  
Consumer Equipment Division**

**TM1426 (01SEP96)  
Replaces TM1426 (01SEP92)**

This technical manual is written for an experienced technician and contains sections that are specifically for this product. It is a part of a total product support program.

The manual is organized so that all the information on a particular system is kept together. The order of grouping is as follows:











- Table of Contents
- Specifications
- Component Location
- System Schematic
- Theory of Operation
- Troubleshooting Chart
- Diagnostics
- Tests & Adjustments
- Repair

*NOTE: Depending on the particular section or system being covered, not all of the above groups may be used.*

Each section will be identified with a symbol rather than a number. The groups and pages within a section will be consecutively numbered.

All information, illustrations and specifications in this manual are based on the latest information available at the time of publication. The right is reserved to make changes at any time without notice.

We appreciate your input on this manual. To help, there are postage paid post cards included at the back. If you find any errors or want to comment on the layout of the manual please fill out one of the cards and mail it back to us.

<b>Safety</b>	
<b>General Information</b>	
<b>Engine—240/245 (FC420V)</b>	
<b>Engine—260/265 (FC540V)</b>	
<b>Engine—285/320 (FD590V)</b>	
<b>Fuel Injection System— 285/320 (FD590V)</b>	
<b>Electrical Systems</b>	
<b>Gear Power Train— 240/260</b>	
<b>Hydrostatic Power Train— 245/265/285/320</b>	
<b>Steering</b>	
<b>Hydraulics</b>	
<b>Miscellaneous Repair</b>	<b>M</b>
<b>Index</b>	

COPYRIGHT© 1995  
 JOHN DEERE HORICON WORKS  
 Horicon, Wisconsin  
 All rights reserved

# CONTENTS



	Page
<b>SAFETY .....</b>	<b>1-2</b>
RECOGNIZE SAFETY INFORMATION .....	1-2
UNDERSTAND SIGNAL WORDS .....	1-2
FOLLOW SAFETY INSTRUCTIONS .....	1-2
HANDLE FLUIDS SAFELY - AVOID FIRES .....	1-2
PREVENT BATTERY EXPLOSIONS .....	1-3
PREPARE FOR EMERGENCIES .....	1-3
PREVENT ACID BURNS .....	1-3
SERVICE COOLING SYSTEM SAFELY .....	1-4
AVOID HIGH-PRESSURE FLUIDS .....	1-4
PARK MACHINE SAFELY .....	1-4
SUPPORT MACHINE PROPERLY .....	1-4
WEAR PROTECTIVE CLOTHING .....	1-5
WORK IN CLEAN AREA .....	1-5
SERVICE MACHINES SAFELY .....	1-5
WORK IN VENTILATED AREA .....	1-5
ILLUMINATE WORK AREA SAFELY .....	1-6
REPLACE SAFETY SIGNS .....	1-6
USE PROPER LIFTING EQUIPMENT .....	1-6
SERVICE TIRES SAFELY .....	1-6
AVOID HEATING NEAR PRESSURIZED FLUID LINES .....	1-7
REMOVE PAINT BEFORE WELDING OR HEATING .....	1-7
USE PROPER TOOLS .....	1-7
DISPOSE OF WASTE PROPERLY .....	1-7
LIVE WITH SAFETY .....	1-8

**<https://www.ebooklibonline.com>**

Hello dear friend!

Thank you very much for reading.

Enter the link into your browser.

The full manual is available for immediate download.

**<https://www.ebooklibonline.com>**



**SAFETY**

**RECOGNIZE SAFETY INFORMATION**



TS1389

This is the safety-alert symbol. When you see this symbol on your machine or in this manual, be alert to potential for personal injury.

Follow recommended precautions and safe operating practices.

**UNDERSTAND SIGNAL WORDS**



TS187

A signal word - DANGER, WARNING, or CAUTION - is used with the safety-alert symbol. DANGER identifies the most serious hazards.

DANGER or WARNING safety signs are located near specific hazards. General precautions are listed on CAUTION safety signs. CAUTION also call attention to safety messages in this manual.

**FOLLOW SAFETY INSTRUCTIONS**

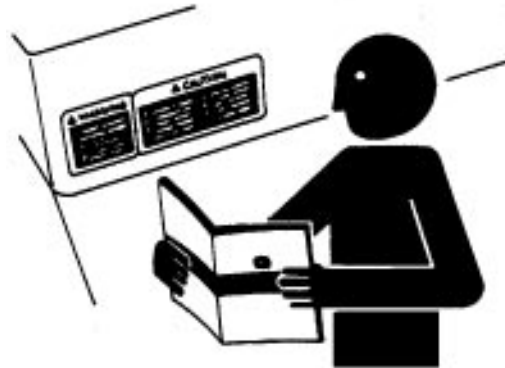

TS201

Carefully read all safety messages in this manual and on your machine safety signs. Keep safety signs in good condition. Replace missing or damaged safety signs. Be sure new equipment components and repair parts include the current safety signs. Replacement safety signs are available from your John Deere dealer.

Learn how to operate the machine and how to use controls properly. DO NOT let anyone operate without instruction.

Keep your machine in proper working condition. Unauthorized modifications to the machine may impair the function and/or safety and affect machine life.

If you DO NOT understand any part of this manual and need assistance, contact your John Deere dealer.

**HANDLE FLUIDS SAFELY - AVOID FIRES**



TS227

When you work around fuel, DO NOT smoke or work near heaters or other fire hazards.

Store flammable fluids away from fire hazards. DO NOT incinerate or puncture pressurized containers.

Make sure machine is clean of trash, grease, and debris.

DO NOT store oily rags; they can ignite and burn spontaneously.

**PREVENT BATTERY EXPLOSIONS**

TS204

Keep sparks, lighted matches, and open flame away from the top of battery. Battery gas can explode.

Never check battery charges by placing a metal object across the posts. Use a volt-meter or hydrometer.

DO NOT charge a frozen battery; it may explode. Warm battery to **16°C (60°F)**.

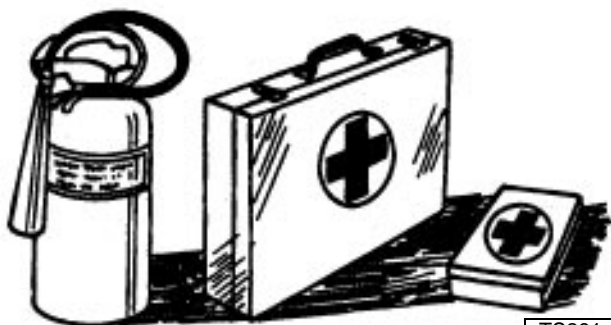
**PREPARE FOR EMERGENCIES**

TS291

Be prepared if a fire starts.

Keep a first aid kit and fire extinguisher handy.

Keep emergency numbers for doctors, ambulance service, hospital, and fire department near your telephone.

**PREVENT ACID BURNS**

TS203

Sulfuric acid in battery electrolyte is poisonous. It is strong enough to burn skin, eat holes in clothing, and cause blindness if splashed into eyes.

Avoid the hazard by:

1. Filling batteries in a well-ventilated area.
2. Wearing eye protection and rubber gloves.
3. Avoiding breathing fumes when electrolyte is added.
4. Avoiding spilling or dripping electrolyte.
5. Use proper jump start procedure.

If you spill acid on yourself:

1. Flush your skin with water.
2. Apply baking soda or lime to help neutralize the acid.
3. Flush your eyes with water for **10—15** minutes. Get medical attention immediately.

If acid is swallowed:

1. Drink large amounts of water or milk.
2. Then drink milk of magnesia, beaten eggs, or vegetable oil.
3. Get medical attention immediately.



**SERVICE COOLING SYSTEM SAFELY**



TS281

Explosive release of fluids from pressurized cooling system can cause serious burns.

Shut off engine. Only remove filler cap when cool enough to touch with bare hands. Slowly loosen cap to first stop to relieve pressure before removing completely.

**AVOID HIGH-PRESSURE FLUIDS**



X9811

Escaping fluid under pressure can penetrate the skin causing serious injury.

Avoid the hazard by relieving pressure before disconnecting hydraulic or other lines. Tighten all connections before applying pressure.

Search for leaks with a piece of cardboard. Protect hands and body from high pressure fluids.

If an accident occurs, see a doctor immediately. Any fluid injected into the skin must be surgically removed within a few hours or gangrene may result. Doctors unfamiliar with this type of injury should reference a knowledgeable medical source. Such information is available from Deere & Company Medical Department in Moline, Illinois, U.S.A.

**PARK MACHINE SAFELY**

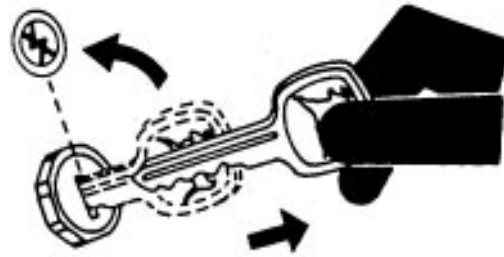

TS230

Before working on the machine:

- Lower all equipment to the ground.
- Stop the engine and remove the key.
- Disconnect the battery ground strap.
- Hang a "DO NOT OPERATE" tag in operator station.

**SUPPORT MACHINE PROPERLY**



TS229

Always lower the attachment or implement to the ground before you work on the machine. If you must work on a lifted machine or attachment, securely support the machine or attachment.

DO NOT support the machine on cinder blocks, hollow tiles, or props that may crumble under continuous load. DO NOT work under the machine that is supported solely by a jack. Follow recommended procedures in this manual.

**WEAR PROTECTIVE CLOTHING**

TS206

Wear close fitting clothing and safety equipment appropriate to the job.

Prolonged exposure to loud noise can cause impairment or loss of hearing.

Wear a suitable hearing protective device such as earmuffs or earplugs to protect against objectionable or uncomfortable loud noises.

Operating equipment safely requires the full attention of the operator. DO NOT wear radio or music headphones while operating machine.

**WORK IN CLEAN AREA**

T6642EJ

Before starting a job:

- Clean work area and machine.
- Make sure you have all necessary tools to do your job.
- Have the right parts on hand.
- Read all instructions thoroughly; DO NOT attempt shortcuts.

**SERVICE MACHINES SAFELY**

TS228

Tie long hair behind your head. DO NOT wear a necktie, scarf, loose clothing, or necklace when you work near machine tools or moving parts. If these items were to get caught, severe injury could result.

Remove rings and other jewelry to prevent electrical shorts and entanglement in moving parts.

**WORK IN VENTILATED AREA**

TS220

**WARNING: California Proposition 65 Warning**

Gasoline engine exhaust from this product contains chemicals known to the State of California to cause cancer, birth defects, or other reproductive harm.

Engine exhaust fumes can cause sickness or death. If it is necessary to run an engine in an enclosed area, remove the exhaust fumes from the area with an exhaust pipe extension.

If you DO NOT have an exhaust pipe extension, open the doors and get outside air into the area.



## **ILLUMINATE WORK AREA SAFELY**



TS223

Illuminate your work area adequately but safely. Use a portable safety light for working inside or under the machine. Make sure the bulb is enclosed by a wire cage. The hot filament of an accidentally broken bulb can ignite spilled fuel or oil.

## **USE PROPER LIFTING EQUIPMENT**



TS226

Lifting heavy components incorrectly can cause severe injury or machine damage.

Follow recommended procedure for removal and installation of components in the manual.

## **REPLACE SAFETY SIGNS**



TS201

Replace missing or damaged safety signs. See the machine operator's manual for correct safety sign placement.

## **SERVICE TIRES SAFELY**



TS952

Explosive separation of a tire and rim parts can cause serious injury or death.

**DO NOT** attempt to mount a tire unless you have the proper equipment and experience to perform the job.

Always maintain the correct tire pressure. **DO NOT** inflate the tires above the recommended pressure. Never weld or heat a wheel and tire assembly. The heat can cause an increase in air pressure resulting in a tire explosion. Welding can structurally weaken or deform the wheel.

When inflating tires, use a clip-on chuck and extension hose long enough to allow you to stand to one side and **NOT** in front of or over the tire assembly. Use a safety cage if available.

Check wheels for low pressure, cuts, bubbles, damaged rims or missing lug bolts and nuts.

## AVOID HEATING NEAR PRESSURIZED FLUID LINES



Flammable spray can be generated by heating near pressurized fluid lines, resulting in severe burns to yourself and bystanders. **DO NOT** heat by welding, soldering, or using a torch near pressurized fluid lines or other flammable materials. Pressurized lines can be accidentally cut when heat goes beyond the immediate flame area.

## REMOVE PAINT BEFORE WELDING OR HEATING

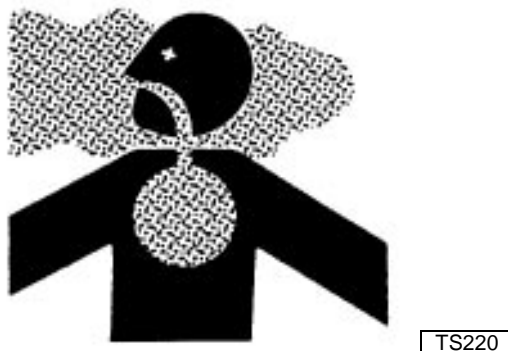

Avoid potentially toxic fumes and dust.

Hazardous fumes can be generated when paint is heated by welding, soldering, or using a torch.

Do all work outside or in a well ventilated area. Dispose of paint and solvent properly.

Remove paint before welding or heating.

- If you sand or grind paint, avoid breathing the dust. Wear an approved respirator.

- If you use solvent or paint stripper, remove stripped with soap and water before welding. Remove solvent or paint stripper containers and other flammable material from area. Allow fumes to disperse at least 15 minutes before welding or heating.



## USE PROPER TOOLS



Use tools appropriate to the work. Makeshift tools and procedures can create safety hazards.

Use power tools only to loosen threaded parts and fasteners.

For loosening and tightening hardware, use the correct size tools. **DO NOT** use U.S. measurement tools on metric fasteners. Avoid bodily injury caused by slipping wrenches.

Use only service parts meeting John Deere specifications.

## DISPOSE OF WASTE PROPERLY



TS1133

Improperly disposing of waste can threaten the environment and ecology. Potentially harmful waste used with John Deere equipment include such items as oil, fuel, coolant, brake fluid, filters, and batteries.

## SAFETY

---



Use leakproof containers when draining fluids. DO NOT use food or beverage containers that may mislead someone into drinking from them.

DO NOT pour waste onto the ground, down a drain, or into any water source.

Air conditioning refrigerants escaping into the air can damage the Earth's atmosphere. Government regulations may require a certified air conditioning service center to recover and recycle used air conditioning refrigerants.

Inquire on the proper way to recycle or dispose of waste from your local environmental or recycling center, or from your John Deere dealer.

## LIVE WITH SAFETY



TS231

Before returning machine to customer, make sure machine is functioning properly, especially the safety systems. Install all guards and shields.

# CONTENTS

	Page
<b>GENERAL SPECIFICATIONS</b> .....	<b>2-3</b>
MACHINE SPECIFICATIONS .....	2-3
TEST AND ADJUSTMENT SPECIFICATIONS .....	2-7
SERVICE RECOMMENDATIONS .....	2-9
<b>METRIC FASTENER TORQUE VALUES</b> .....	<b>2-11</b>
<b>INCH FASTENER TORQUE VALUES</b> .....	<b>2-12</b>
<b>GASOLINE SPECIFICATIONS</b> .....	<b>2-13</b>
GASOLINE STORAGE .....	2-13
4-CYCLE ENGINES - EUROPE .....	2-14
GASOLINE STORAGE .....	2-14
4-CYCLE GASOLINE ENGINE OIL - NORTH AMERICA .....	2-15
4-CYCLE GASOLINE ENGINE OIL - EUROPE .....	2-16
4-CYCLE GASOLINE ENGINE OIL - EUROPE .....	2-17
BREAK-IN 4-CYCLE GASOLINE ENGINE OIL - EUROPE .....	2-18
GEAR CASE OIL - NORTH AMERICA .....	2-19
GEAR CASE OIL - EUROPE .....	2-20
GEAR TRANSMISSION GREASE - NORTH AMERICA .....	2-21
GEAR TRANSMISSION GREASE - EUROPE .....	2-22
<b>GREASE SPECIFICATIONS</b> .....	<b>2-23</b>
GREASE - NORTH AMERICA .....	2-23
GREASE - EUROPE .....	2-24
ALTERNATIVE LUBRICANTS .....	2-25
SYNTHETIC LUBRICANTS .....	2-25
LUBRICANT STORAGE .....	2-25
MIXING OF LUBRICANTS .....	2-25
OIL FILTERS .....	2-25
ALTERNATIVE LUBRICANTS .....	2-26
SYNTHETIC LUBRICANTS .....	2-26
LUBRICANT STORAGE .....	2-26
MIXING OF LUBRICANTS .....	2-26
OIL FILTERS .....	2-26
<b>COOLANT SPECIFICATIONS</b> .....	<b>2-27</b>
DIESEL AND GASOLINE ENGINE COOLANT - NORTH AMERICA .....	2-27
DIESEL AND GASOLINE ENGINE COOLANT DRAIN INTERVAL - NORTH AMERICA .....	2-27
GASOLINE ENGINE COOLANT - EUROPE .....	2-28
GASOLINE ENGINE COOLANT DRAIN INTERVAL - EUROPE .....	2-28





	<b>Page</b>
<b>SERIAL NUMBER LOCATIONS . . . . .</b>	<b>2-29</b>
SERIAL NUMBERS . . . . .	2-29
LOCATIONS . . . . .	2-29
PRODUCT IDENTIFICATION NUMBER LOCATION . . . . .	2-29
ENGINE SERIAL NUMBER LOCATION . . . . .	2-29
HYDROSTATIC TRANSMISSION SERIAL NUMBER LOCATION - 245/265/285/320 . . . . .	2-29
HYDRAULIC LIFT VALVE SERIAL NUMBER LOCATION - 320 . . . . .	2-29
<b>OPERATIONAL CHECKOUT PROCEDURE . . . . .</b>	<b>2-30</b>
BEFORE YOU START . . . . .	2-30
BRAKE PEDAL LOCK CHECK . . . . .	2-30
INDICATOR LAMP CHECK - ENGINE OFF . . . . .	2-31
TRANSMISSION NEUTRAL START CHECK . . . . .	2-31
PTO/SAFETY START CHECK . . . . .	2-32
STARTING CIRCUIT CHECK - HYDROSTATIC TRACTORS . . . . .	2-32
STARTING CIRCUIT CHECK - GEAR TRACTORS . . . . .	2-32
INDICATOR LAMP CHECK - ENGINE RUNNING . . . . .	2-33
THROTTLE AND CHOKE LEVER CHECK - ENGINE RUNNING . . . . .	2-33
PTO CLUTCH CHECK . . . . .	2-34
SEAT SWITCH CHECK - PTO AND IGNITION . . . . .	2-34
TRANSMISSION FORWARD AND REVERSE CHECK . . . . .	2-34
TRANSMISSION NEUTRAL CREEP CHECK - HYDROSTATIC TRACTORS . . . . .	2-35
BRAKE NEUTRAL RETURN CHECK - HYDROSTATIC TRACTORS . . . . .	2-35
HEADLIGHT CHECK . . . . .	2-36
HYDRAULIC LIFT SYSTEM CHECK . . . . .	2-36

## GENERAL SPECIFICATIONS

### MACHINE SPECIFICATIONS

Model:	240	245	260
<b>ENGINE</b>			
Manufacturer	Kawasaki	Kawasaki	Kawasaki
Model number	FC420V	FC420V	FC540V
Horsepower	14 (10.4 kW)	14 (10.4 kW)	17 (12.6kW)
Type of Valves	Overhead	Overhead	Overhead
Type of Cooling	Air	Air	Air
Number of Cylinders	One	One	One
Crankshaft Alignment	Vertical	Vertical	Vertical
Stroke/Cycle	Four	Four	Four
Bore	89 mm (3.5 in.)	89 mm (3.5 in.)	89 mm (3.5 in.)
Stroke	68 mm (2.7 in.)	68 mm (2.7 in.)	86 mm (3.38 in.)
Displacement	423 cm <sup>3</sup> (25.8 cu. in.)	423 cm <sup>3</sup> (25.8 cu. in.)	535 cm <sup>3</sup> (32.6 cu. in.)
Compression Ratio	8.4:1	8.4:1	8.3:1
Fast Idle (no load)	3350 ± 100 rpm	3350 ± 100 rpm	3350 ± 100 rpm
Slow Idle (no load)	1450 ± 75 rpm	1450 ± 75 rpm	1450 ± 75 rpm
Air Filter	Dry, Replaceable Foam Pre-Cleaner	Dry, Replaceable Foam Pre-Cleaner	Dry, Replaceable Foam Pre-Cleaner
Crankcase Capacity with Filter	1.5 L (3.17 U.S. pt)	1.5 L (3.17 U.S. pt)	1.9 L (4.0 U.S. pt)
Replaceable Oil Filter	Optional	Optional	Standard
<b>ELECTRICAL SYSTEM</b>			
Charging System	Stator	Stator	Stator
Capacity	14 Amp. Reg.	14 Amp. Reg.	16 Amp. Reg.
Battery Type	BCI Group, U1	BCI Group, U1	BCI Group, U1
Battery Voltage	12 Volts	12 Volts	12 Volts
Battery Reserve Capacity at 25 Amp.	41 Min.	60 Min.	41 Min.
Battery Cold Cranking Amp. at 0°F	340 Amp.	335 Amp.	340 Amp.
<b>FUEL SYSTEM</b>			
Fuel Tank Capacity	11.4 L (3.0 gal)	11.4 L (3.0 gal)	11.4 L (3.0 gal)
Fuel Type	Unleaded Gasoline	Unleaded Gasoline	Unleaded Gasoline
Fuel Filter	Replaceable In Line	Replaceable In Line	Replaceable In Line



## MACHINE SPECIFICATIONS (CONTINUED)

Model:	240	245	260
POWER TRAIN			
Transmission	Gear Transaxle	Hydrostatic	Gear Transaxal
Manufacturer	Kanzaki	Sundstrand	Kanzaki
Lubricant*	J20D	J20D	J20D
S/N(130001- )	Low Viscosity HY-GARD	Low Viscosity HY-GARD	Low Viscosity HY-GARD
Capacity	3.8 L (1 U.S. gal)	2.5 L (2.6 U.S. qt)	3.8 L (1 U.S. gal)

\*DO NOT mix oils when adding oil, make sure color of add lubricant matches existing oil.

Model:	265	285/320
ENGINE		
Manufacturer	Kawasaki	Kawasaki
Model Number	FC540V	FD590V
Horsepower	17 (12.6kW)	18 (13.4kW)
Type of Valves	Overhead	Overhead
Type of Cooling	Air	Liquid
Number of Cylinders	One	Two
Crankshaft Alignment	Vertical	Vertical
Stroke/Cycle	Four	Four
Bore	89 mm (3.5 in.)	74 mm (2.9 in.)
Stroke	86 mm (3.36 in.)	68 mm (2.7 in.)
Displacement	535 cm <sup>3</sup> (32.6 cu. in.)	585 cm <sup>3</sup> (35.7 cu. in.)
Compression Ratio	8.3:1	8.7:1
Fast Idle (no load)	3350 ± 100 rpm	3350 ± 100 rpm
Slow Idle (no load)	1550 ± 75 rpm	1550 ± 75 rpm
Air Filter	Dry, Replaceable Foam Pre-Cleaner	Dry, Replaceable Foam Pre-Cleaner
Crankcase Capacity with Filter	1.8 L (3.8 pt.)	1.9 L (4.0 pt.)
Replaceable Oil Filter	Standard	Standard
Coolant Capacity	N/A	3.1 L (3.3 U.S. Qt.)
ELECTRICAL SYSTEM		
Charging System	Stator	Stator
Capacity	16 Amp. Reg.	16 Amp. Reg.
Battery Type	BCI Group, 22F	BCI Group, 22F
Battery Voltage	12 Volts	12 Volts
Batter Reserve		
Capacity at 25 Amp.	60 Min.	60 Min.
Battery Cold Cranking Amp. at 0°F	335 Amp.	335 Amp.

**MACHINE SPECIFICATIONS (CONTINUED)**

<b>Model:</b>	<b>265</b>	<b>285/320</b>
<b>FUEL SYSTEM</b>		
Fuel Tank Capacity	11.4 L (3.0 Gal.) (Regular Leaded or Unleaded Gasoline)	11.4 L (3.0 Gal.) (Regular Leaded or Unleaded Gasoline)
Fuel Filter	Replaceable In Line	Replaceable In Line
<b>POWER TRAIN</b>		
Transmission	Hydrostatic	Hydrostatic
Manufacturer	Sundstrand	Sundstrand
Lubricant*	Low Viscosity	Low Viscosity
S/N(130001- )	HY-GARD®	HY-GARD®
Specification	J20D	J20D
Capacity	2.5 L (2.6 U.S. qt.)	2.5 L (2.6 U.S. qt.)



*\*DO NOT mix oils when adding oil, make sure color of add lubricant matches existing oil.*

**CHASSIS DIMENSIONS**

Wheelbase .....	122 cm (47.9 in.)
Overall Length.....	182 cm (71.5 in.)
With Read Bagger .....	2.37 m (93.5 in.)
With Front Quick-Thatch Wts. ....	2.02 m (79.5 in.)
With Rear Quick-Thatch Wts. ....	1.93 m (76 in.)
Overall Height .....	111 cm (43.6 in.)
Overall Width	
Min. (Tractor Only).....	1.0 m (39 in.)
Max. (Tractor Only).....	1.1 m (41.5 in.)
With 38 in. Mower:	
Deflector Up .....	104 cm (41 in.)
Deflector Down .....	136 cm (53.5 in.)
With Read Bagger .....	126 cm (49.5 in.)
With 46 in. Mower:	
Deflector Up .....	136 cm (53.5 in.)
Deflector Down .....	145 cm (57 in.)
With 48 in. Mower:	
Deflector Up .....	138 cm (54.5 in.)
Deflector Down .....	157 cm (62.0 in.)
With 50 in. Mower:	
Deflector Up .....	144 cm (56.5 in.)
Deflector Down .....	155 cm (61 in.)

CHASSIS DIMENSIONS (CONTINUED)

OVERALL WIDTH (CONTINUED)

Turning Radius

Inside Read Wheel .....	64 cm (25 in.)
Outside Read Wheel .....	203 cm (80 in.)

Wheel Tread

Front .....	80 cm (31.5 in.)
Rear (320) .....	74 cm (29 in.)

TIRES

Type

Front .....	Turf
Rear .....	Turf or Bar

Size

Front .....	16 x 6.5-8
Rear .....	23 x 10.5-12

Inflation Pressure

Front	All (except 32070) - 110 kPa (10-16 psi)
Front .....	32070 - 97 kPa (10-14 psi)
Rear .....	40 - 70 kPa (6-10 psi)

BRAKES

(S.N. - 130000) .....	Expanding Shoe
(S.N. 130001 - ) .....	Wet Disc

PTO CLUTCH

Type .....	Electric
------------	----------

IMPLEMENT LIFT

All (except 320) .....	Manual W/Depth Stop and Adjustable Lift Spring
320 .....	Hydraulic W/Depth Stop and Adjustable Lift Spring

(Specification and design subject to change without notice.)

**TEST AND ADJUSTMENT SPECIFICATIONS**

ITEM	SPECIFICATION
<b>ENGINE</b>	
Fast Idle (except fuel injected 285) . . . . .	3350 ± 50 rpm
Slow Idle . . . . .	1450 ± 75 rpm
Compression (Min.)	
240, 245, 260, 265 . . . . .	483 kPa (71 psi)
285, 320 . . . . .	588 kPa (85 psi)
Intake and Exhaust Valve Clearance (Cold)	
240, 245, 260, 265 . . . . .	0.15 mm (0.006 in.)
285, 320 . . . . .	0.25 mm (0.01 in.)
Crankcase Vacuum (Min.)	
240, 245, 260, 265 . . . . .	25 cm (10 in. water)
285, 320 . . . . .	18 cm (7 in. water)
Oil Pressure (Min.) . . . . .	240 kPa (35 psi)
Fuel Pump Pressure (Min.)	
240, 245, 260, 265 . . . . .	6 kPa (0.9 psi)
285, 320 . . . . .	19 kPa (2.8 psi)
Fuel Pump Flow (Min.)	
240, 245 . . . . .	80 ml/15 sec. (2.7 oz./15 sec.)
260, 265 . . . . .	90 ml/15 sec. (3 oz./15 sec.)
285, 320 . . . . .	160 ml/15 sec. (5.4 oz./15 sec.)
Fuel Pressure - Fuel Injected 285 . . . . .	274-284 kPa (40-41 psi)
<b>ELECTRICAL</b>	
Regulated Voltage Output	
240, 245 . . . . .	11 amps (Min.) at 12.2-13.8 V
260, 265 . . . . .	13 amps (Min.) at 12.2-13.8 V
285, 320 . . . . .	15 amps (Min.) at 12.1-13.8 V
Unregulated Voltage Output (Min.)	
240, 245 . . . . .	30 V
260, 265 . . . . .	27 V
285, 320 . . . . .	26 V
Stator Resistance	
240, 245, 260, 265 . . . . .	0.24-0.4 ohms
285, 320 . . . . .	0.12-0.19 ohms
Starter Amp Draw (Max.)	
240, 245 . . . . .	60 amps at 500 rpm
260, 265 . . . . .	85 amps at 500 rpm
285, 320 . . . . .	72 amps at 500 rpm
Starter No-Load Amperage (Max.)	
240, 245, 285, 320 . . . . .	50 amps at 6000 rpm
260, 265 . . . . .	50 amps at 5000 rpm
Starter No-Load RPM	
240, 245, 285, 320 . . . . .	6000 rpm
260, 265 . . . . .	5000 rpm



**TEST AND ADJUSTMENT SPECIFICATIONS (CONTINUED)**

<b>ITEM</b>	<b>SPECIFICATION</b>
<b>ELECTRICAL</b>	
Ignition Coil Air Gap - 240, 245, 260, 265 . . . . .	0.3 mm (0.012 in.)
Ignition Coil Resistance - 240, 245, 260, 265	
Primary Lead and Core . . . . .	0.48-0.72 ohms
Spark Plug Lead and Core . . . . .	10.9-16.3 K ohms
Pulsar Coil Resistance - 285, 320 . . . . .	85-270 ohms
Ignition Coil Resistance - 285, 320	
Primary Coil . . . . .	3.4-4.6 ohms
Secondary Coil . . . . .	10.4-15.5 K ohms
Core Insulation Continuity . . . . .	Infinite
Spark Plug Gap:	
240, 245, 260, 265 . . . . .	0.7-0.8 mm (0.028-0.032 in.)
285, 320 . . . . .	0.7 mm (0.028 in.)
PTO Clutch Amp Draw (Min.) . . . . .	.4 amps
PTO Clutch Air Gap	
Warner . . . . .	0.38-0.64 mm (0.015-0.025 in.)
Ogura . . . . .	0.30-0.51 mm (0.012-0.020 in.)
Throttle Sensor Resistance - Fuel Injected 285	
Input Terminal . . . . .	3.3-6.8 K ohms
Output Terminal (idle) . . . . .	0.2-0.5 K ohms
Throttle Sensor Output Voltage - Fuel Injected 285 . . . . .	0.35-0.38 V
Air Temperature Sensor Resistance - Fuel Injected 285 . . . . .	1.3-7.4 K ohms
Coolant Temperature Sensor Resistance - Fuel Injected 285 . . . . .	1.3-7.4 K ohms
Fuel Injector Resistance - Fuel Injected 285 . . . . .	11.1-12.9 ohms
<b>POWER TRAIN</b>	
Clutch Pedal Spring Length . . . . .	54-56 mm (2.1-2.2 in.)
Belt Guide Clearance	
Belt Tension and Bellcrank Idler . . . . .	1-5 mm (0.04-0.2 in.)
Engine Sheave . . . . .	1-4 mm (0.04-0.16 in.)
Hydrostatic Control Lever Tension . . . . .	22-36 N (5-8 lbs)
Charge Pressure:	
245, 265, 285 . . . . .	193-490 kPa (28-71 psi)
320 . . . . .	276-621 kPa (40-90 psi)
<b>BRAKES</b>	
Brake Lever Rod Washer to Retainer Clearance . . . . .	8-14 mm (0.3-0.5 in.)
Brake Rod Cotter Pin to Retainer Clearance 240/260 (130001- ) . . . . .	22-28 mm (0.8-1.1 in.)

**SERVICE RECOMMENDATIONS**

**O-Ring Boss Fittings**

STRAIGHT FITTING

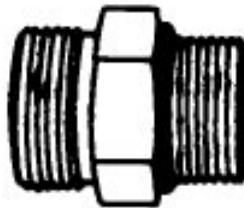

T6243AE

1. Inspect O-ring boss seat for dirt or defects.
2. Lubricate O-ring with petroleum jelly. Place electrical tape over threads to protect O-ring. Slide O-ring over tape and into O-ring groove of fitting. Remove tape.
3. Tighten fitting to torque value shown on chart.

ANGLE FITTING

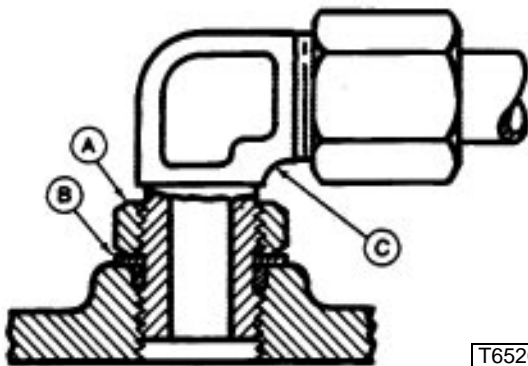

T6520AB

1. Back-off lock nut (A) and back-up washer (B) completely to head-end (C) of fitting.
2. Turn fitting into threaded boss until back-up washer contacts face of boss.
3. Turn fitting head-end counterclockwise to proper index (maximum of one turn).
4. Hold fitting head-end with a wrench and tighten locknut and back-up washer to proper torque value.

**NOTE:** *DO NOT* allow hoses to twist when tightening fittings.

O-RING BOSS FITTING

Thread Size	N·m	lb·ft
3/8-24 UNF .....	8 .....	6
7/16-20 UNF .....	12 .....	9
1/2-20 UNF .....	16 .....	12
9/16-18 UNF .....	24 .....	18
3/4-16 UNF .....	46 .....	34
7/8-14 UNF .....	62 .....	46
1-1/16-12 UN .....	102 .....	75
1-3/16-12 UN .....	122 .....	90
1-5/16-12 UN .....	142 .....	105
1-5/8-12 UN .....	190 .....	140
1-7/8-12 UN .....	217 .....	160

**NOTE:** *Torque tolerance is ± 10%.*

**Flat Face O-Ring Seal Fittings**



T6243AD

1. Inspect the fitting sealing surfaces. They must be free of dirt or defects.
2. Inspect the O-ring. It must be free of damage or defects.
3. Lubricate O-rings and install into groove using petroleum jelly to hold in place.
4. Push O-ring into the groove with plenty of petroleum jelly so O-ring is not displaced during assembly.
5. Index angle fittings and tighten by hand pressing joint together to insure O-ring remains in place.
6. Tighten fitting or nut to torque value shown on the chart per dash size stamped on the fitting. **DO NOT** allow hoses to twist when tightening fittings.

## FLAT FACE O-RING SEAL FITTING TORQUE

Tube	Nominal		Dash	Thread		Swivel Nut		Bulkhead	
	O.D.			Size	Size	Torque		Nut Torque	
mm	(in.)		Size	In.	N-m	(lb-ft)	N-m	(lb-ft)	
6.35	0.250		-4	9/16-18	16	13	5.0	3.5	
9.52	0.375		-6	11/16-16	24	18	9.0	6.5	
12.70	0.500		-8	13/16-16	50	37	17.0	12.5	
15.88	0.625		-10	1-14	69	51	17.0	12.5	
19.05	0.750		-12	1 3/16-12	102	75	17.0	12.5	
22.22	0.875		-14	1 3/16-12	102	75	17.0	12.5	
25.40	1.000		-16	1 7/16-12	142	105	17.0	12.5	
31.75	1.250		-20	1 11/16-12	190	140	17.0	12.5	
38.10	1.500		-24	1-12	217	160	17.0	12.5	

NOTE: Torque tolerance is + 15 -20%.

METRIC FASTENER TORQUE VALUES

Property Class and Head Markings	4.8		8.8		9.8		10.9		12.9	
Property Class and Nut Markings	5		10		10		10		12	

TS1163



SIZE	Class 4.8				Class 8.8 or 9.8				Class 10.9				Class 12.9			
	Lubricated <sup>a</sup>		Dry <sup>a</sup>		Lubricated <sup>a</sup>		Dry <sup>a</sup>		Lubricated <sup>a</sup>		Dry <sup>a</sup>		Lubricated <sup>a</sup>		Dry <sup>a</sup>	
	N·m	lb-ft	N·m	lb-ft	N·m	lb-ft	N·m	lb-ft	N·m	lb-ft	N·m	lb-ft	N·m	lb-ft	N·m	lb-ft
M6	4.8	3.5	6	4.5	9	6.5	11	8.5	13	9.5	17	12	15	11.5	19	14.5
M8	12	8.5	15	11	22	16	28	20	32	24	40	30	37	28	47	35
M10	23	17	29	21	43	32	55	40	63	47	80	60	75	55	95	70
M12	40	29	50	37	75	55	95	70	110	80	140	105	130	95	165	120
M14	63	47	80	60	120	88	150	110	175	130	225	165	205	150	260	109
M16	100	73	125	92	190	140	240	175	275	200	350	225	320	240	400	300
M18	135	100	175	125	260	195	330	250	375	275	475	350	440	325	560	410
M20	190	140	240	180	375	275	475	350	530	400	675	500	625	460	800	580
M22	260	190	330	250	510	375	650	475	725	540	925	675	850	625	1075	800
M24	330	250	425	310	650	475	825	600	925	675	1150	850	1075	800	1350	1000
M27	490	360	625	450	950	700	1200	875	1350	1000	1700	1250	1600	1150	2000	1500
M30	675	490	850	625	1300	950	1650	1200	1850	1350	2300	1700	2150	1600	2700	2000
M33	900	675	1150	850	1750	1300	2200	1650	2500	1850	3150	2350	2900	2150	3700	2750
M36	1150	850	1450	1075	2250	1650	2850	2100	3200	2350	4050	3000	3750	2750	4750	3500

DO NOT use these hand torque values if a different torque value or tightening procedure is given for a specific application. Torque values listed are for general use only and include a ±10% variance factor. Check tightness of fasteners periodically. DO NOT use air powered wrenches.

Shear bolts are designed to fail under predetermined loads. Always replace shear bolts with identical grade.

Fasteners should be replaced with the same class. Make sure fastener threads are clean and that you properly start thread engagement. This will prevent them from failing when tightening.











When bolt and nut combination fasteners are used, torque values should be applied to the **NUT** instead of the bolt head.

Tighten toothed or serrated-type lock nuts to the full torque value.

<sup>a</sup> "Lubricated" means coated with a lubricant such as engine oil, or fasteners with phosphate and oil coatings. "Dry" means plain or zinc plated (yellow dichromate - Specification JDS117) without any lubrication.

Reference: JDS—G200.

INCH FASTENER TORQUE VALUES

SAE Grade and Head Markings	1 or 2 <sup>b</sup> No Marks 	5  5.1  5.2 	8  8.2 
	2 No Marks 	5  	8  

TS1162

SIZE	Grade 1		Grade 2 <sup>b</sup>		Grade 5, 5.1 or 5.2		Grade 8 or 8.2	
	Lubricated <sup>a</sup>	Dry <sup>a</sup>	Lubricated <sup>a</sup>	Dry <sup>a</sup>	Lubricated <sup>a</sup>	Dry <sup>a</sup>	Lubricated <sup>a</sup>	Dry <sup>a</sup>
	N-m	lb-ft	N-m	lb-ft	N-m	lb-ft	N-m	lb-ft
1/4	3.7	2.8	4.7	3.5	6	4.5	7.5	5.5
5/16	7.7	5.5	10	7	12	9	15	11
3/8	14	10	17	13	22	16	27	20
7/16	22	16	28	20	35	26	44	32
1/2	33	25	42	31	53	39	67	50
9/16	48	36	60	45	75	56	95	70
5/8	67	50	85	62	105	78	135	100
3/4	120	87	150	110	190	140	240	175
7/8	190	140	240	175	190	140	240	175
1	290	210	360	270	290	210	360	270
1-1/8	470	300	510	375	470	300	510	375
1-1/4	570	425	725	530	570	425	725	530
1-3/8	750	550	950	700	750	550	950	700
1-1/2	1000	725	1250	925	990	725	1250	930

DO NOT use these hand torque values if a different torque value or tightening procedure is given for a specific application. Torque values listed are for general use only and include a ±10% variance factor. Check tightness of fasteners periodically. DO NOT use air powered wrenches.

Shear bolts are designed to fail under predetermined loads. Always replace shear bolts with identical grade.

Fasteners should be replaced with the same grade. Make sure fastener threads are clean and that you properly start thread engagement. This will prevent them from failing when tightening.

When bolt and nut combination fasteners are used, torque values should be applied to the **NUT** instead of the bolt head.

Tighten toothed or serrated-type lock nuts to the full torque value.

<sup>a</sup> "Lubricated" means coated with a lubricant such as engine oil, or fasteners with phosphate and oil coatings. "Dry" means plain or zinc plated (yellow dichromate - Specification JDS117) without any lubrication.

<sup>b</sup> "Grade 2" applies for hex cap screws (not hex bolts) up to 152 mm (6-in.) long. "Grade 1" applies for hex cap screws over 152 mm (6-in.) long, and for all other types of bolts and screws of any length.

Reference: JDS—G200.

## GASOLINE SPECIFICATIONS 4-CYCLE ENGINES - NORTH AMERICA

### CAUTION

Gasoline is **HIGHLY FLAMMABLE**, handle it with care.

**DO NOT** refuel machine while:

- indoors, always fill gas tank outdoors;
- machine is near an open flame or sparks;
- engine is running, **STOP** engine;
- engine is hot, allow it to cool sufficiently first;
- smoking.

**Help prevent fires:**

- fill gas tank to bottom of filler neck only;
- be sure fill cap is tight after fueling;
- clean up any gas spills **IMMEDIATELY**;
- keep machine clean and in good repair—free of excess grease, oil, debris, and faulty or damaged parts;
- any storage of machines with gas left in tank should be in an area that is well ventilated to prevent possible igniting of fumes by an open flame or spark, this includes any appliance with a pilot light.

**To prevent fire or explosion caused by STATIC ELECTRIC DISCHARGE** during fueling:

- **ONLY** use a clean, approved **POLYETHYLENE PLASTIC** fuel container and funnel **WITHOUT** any metal screen or filter.

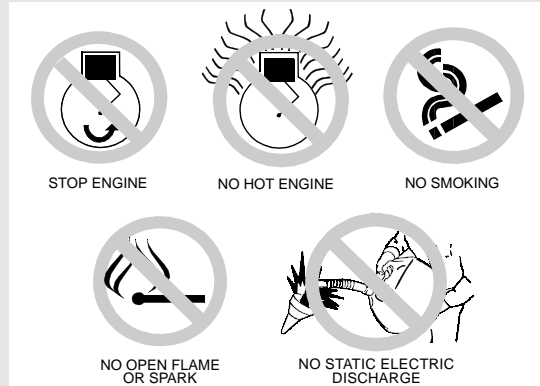

**To avoid engine damage:**

- **DO NOT** mix oil with gasoline;
- **ONLY** use clean, fresh unleaded gasoline with an octane rating (anti-knock index) of 87 or higher;
- fill gas tank at the end of each day's operation to help prevent condensation from forming inside a partially filled tank;
- keep up with specified service intervals.

Use of alternative oxygenated, gasohol blended, unleaded gasoline is acceptable as long as:

- the ethyl or grain alcohol blends **DO NOT** exceed 10% by volume or
- methyl tertiary butyl ether (MTBE) blends **DO NOT** exceed 15% by volume.

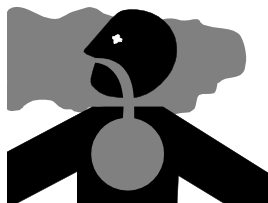

**IMPORTANT: DO NOT** use **METHANOL** gasolines because **METHANOL** is harmful to the environment and to your health.

### WARNING

**California Proposition 65 Warning:** Gasoline engine exhaust from this product contains chemicals known to the State of California to cause cancer, birth defects, or other reproductive harm.

## GASOLINE STORAGE

**IMPORTANT:** Keep all dirt, scale, water or other foreign material out of gasoline.

Keep gasoline stored in a safe, protected area. Storage of gasoline in a clean, properly marked ("**UNLEADED GASOLINE**") **POLYETHYLENE PLASTIC** container **WITHOUT** any metal screen or filter is recommended. **DO NOT** use de-icers to attempt to remove water from gasoline or depend on fuel filters to remove water from gasoline. Use a water separator installed in the storage tank outlet. **BE SURE** to properly discard unstable or contaminated gasoline. When storing unit or gasoline, it is recommended that you add **John Deere Gasoline Conditioner and Stabilizer (TY15977)** or an equivalent to the gasoline. **BE SURE** to follow directions on container and to properly discard empty container.

## 4-CYCLE ENGINES - EUROPE



## CAUTION

Gasoline is **HIGHLY FLAMMABLE**, handle it with care.

**DO NOT** refuel machine while:

- indoors, always fill gas tank outdoors;
- machine is near an open flame or sparks;
- engine is running, **STOP** engine;
- engine is hot, allow it to cool sufficiently first;
- smoking.

**Help prevent fires:**

- fill gas tank to bottom of filler neck only;
- be sure fill cap is tight after fueling;
- clean up any gas spills **IMMEDIATELY**;
- keep machine clean and in good repair—free of excess grease, oil, debris, and faulty or damaged parts;
- any storage of machines with gas left in tank should be in an area that is well ventilated to prevent possible igniting of fumes by an open flame or spark, this includes any appliance with a pilot light.

**To prevent fire or explosion caused by STATIC ELECTRIC DISCHARGE during fueling:**

- **ONLY** use a clean, approved **POLYETHYLENE PLASTIC** fuel container and funnel **WITHOUT** any metal screen or filter.

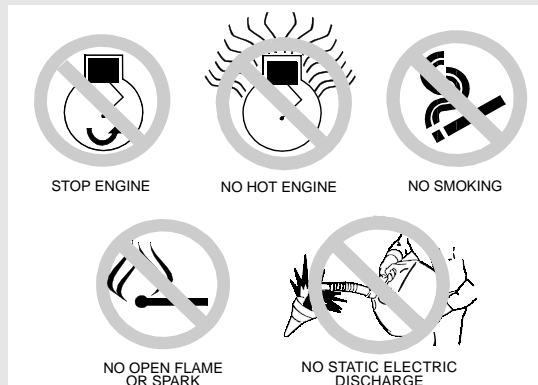

**To avoid engine damage:**

- DO NOT mix oil with gasoline;
- **ONLY** use clean, fresh unleaded gasoline with an octane rating (anti-knock index) of 87 or higher;
- fill gas tank at the end of each day's operation to help prevent condensation from forming inside a partially filled tank;
- keep up with specified service intervals.

Use of alternative oxygenated, gasohol blended, unleaded gasoline is acceptable as long as:

- the ethyl or grain alcohol blends DO NOT exceed 10% by volume or
- methyl tertiary butyl ether (MTBE) blends DO NOT exceed 15% by volume.

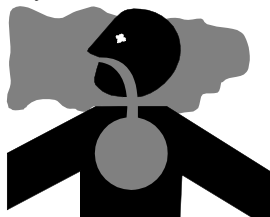

**IMPORTANT: DO NOT** use **METHANOL** gasolines because **METHANOL** is harmful to the environment and to your health.

## GASOLINE STORAGE

**IMPORTANT:** Keep all dirt, scale, water or other foreign material out of gasoline.

Keep gasoline stored in a safe, protected area. Storage of gasoline in a clean, properly marked ("**UNLEADED GASOLINE**") **POLYETHYLENE PLASTIC** container **WITHOUT** any metal screen or filter is recommended. **DO NOT** use de-icers to attempt to remove water from gasoline or depend on fuel filters to remove water from gasoline. Use a water separator installed in the storage tank outlet. **BE SURE** to properly discard unstable or contaminated gasoline. When storing unit or gasoline, it is recommended that you add **John Deere Gasoline Conditioner and Stabilizer (TY15977)** or an equivalent to the gasoline. **BE SURE** to follow directions on container and to properly discard empty container.

## 4-CYCLE GASOLINE ENGINE OIL - NORTH AMERICA

Use the appropriate oil viscosity based on the expected air temperature range during the period between recommended oil changes. Operating outside of these recommended oil air temperature ranges may cause premature engine failure.

The following John Deere oils are **PREFERRED**:

- **PLUS-4®—SAE 10W-40;**
- **TORQ-GARD SUPREME®—SAE 5W-30.**

The following John Deere oils are **also recommended**, based on their specified temperature range:

- **TURF-GARD®—SAE 10W-30;**
- **PLUS-4®—SAE 10W-30;**
- **TORQ-GARD SUPREME®—SAE 30.**

Other oils may be used if above John Deere oils are not available, provided they meet one of the following specifications:

- SAE 10W-40—API Service Classification SG or higher;
- SAE 5W-30—API Service Classification SG or higher;
- SAE 10W-30—API Service Classification SG or higher;
- SAE 30—API Service Classification SC or higher.

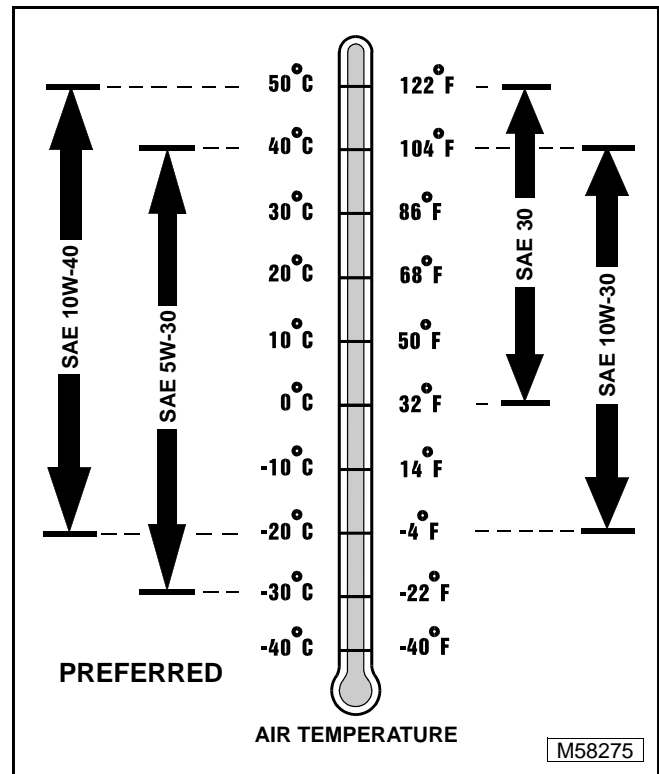

**John Deere Dealers:** You may want to cross-reference the following publications to recommend the proper oil for your customers:

- Module DX, ENOIL2 in JDS-G135;
- Section 530, Lubricants & Hydraulics, of the John Deere Merchandise Sales Guide;
- Lubrication Sales Manual PI7032.

### 4-CYCLE GASOLINE ENGINE OIL - EUROPE

Use the appropriate oil viscosity based on the expected air temperature range during the period between recommended oil changes. Operating outside of these recommended oil air temperature ranges may cause premature engine failure.

The following John Deere oils are **PREFERRED**:

- TORQ-GARD SUPREME®—SAE 10W-40;
- UNI-GARD™—SAE 10W-40;
- TORQ-GARD SUPREME®—SAE 5W-30;
- UNI-GARD™—SAE 5W-30.

The following John Deere oils are **also recommended**, based on their specified temperature range:

- TORQ-GARD SUPREME®—SAE 10W-30;
- UNI-GARD™—SAE 10W-30;
- TORQ-GARD SUPREME®—SAE 30;
- UNI-GARD™—SAE 30.

Other oils may be used if above John Deere oils are not available, provided they meet one of the following specifications:

- CCMC Specification G4 or higher.

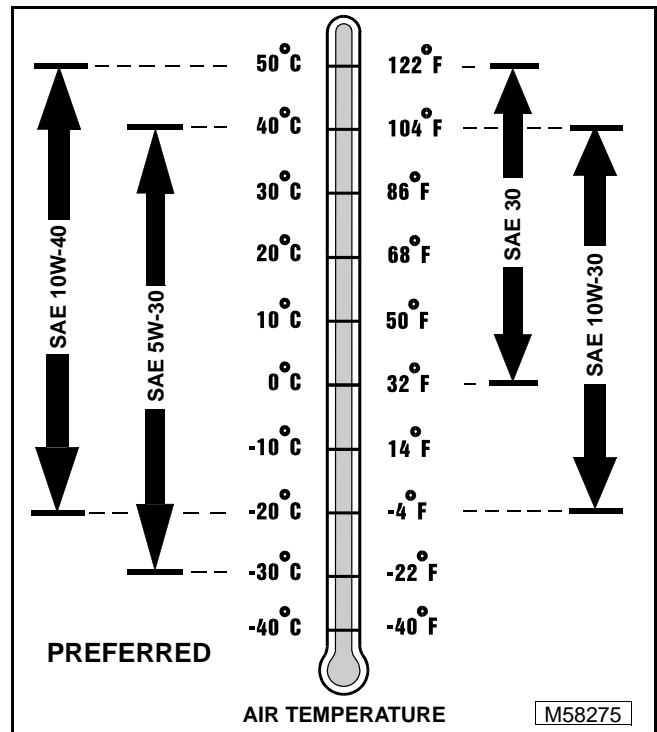

**John Deere Dealers:** You may want to cross-reference the following publications to recommend the proper oil for your customers:

- Module DX, ENOIL2 in JDS-G135;
- Section 530, Lubricants & Hydraulics, of the John Deere Merchandise Sales Guide.

## BREAK-IN 4-CYCLE GASOLINE ENGINE OIL - NORTH AMERICA

**IMPORTANT:** ONLY use a quality break-in oil in rebuilt or remanufactured engines for the first 5 hours (maximum) of operation. DO NOT use oils with heavier viscosity weights than SAE 5W-30 or oils meeting specifications API SG or SH, these oils will not allow rebuilt or remanufactured engines to break-in properly.

The following John Deere oil is **PREFERRED**:

- **BREAK-IN ENGINE OIL.**

**John Deere BREAK-IN ENGINE OIL** is formulated with special additives for aluminum and cast iron type engines to allow the power cylinder components (pistons, rings, and liners as well) to “wear-in” while protecting other engine components, valve train and gears, from abnormal wear. Engine rebuild instructions should be followed closely to determine if special requirements are necessary.

**John Deere BREAK-IN ENGINE OIL** is also recommended for non-John Deere engines, both aluminum and cast iron types.

The following John Deere oil is **also recommended** as a break-in engine oil:

- **TORQ-GARD SUPREME®—SAE 5W-30.**

If the above recommended John Deere oils are not available, use a break-in engine oil meeting the following specification during the first 5 hours (maximum) of operation:

- SAE 5W-30—API Service Classification SE or higher.

**IMPORTANT:** After the break-in period, use the John Deere oil that is recommended for this engine.

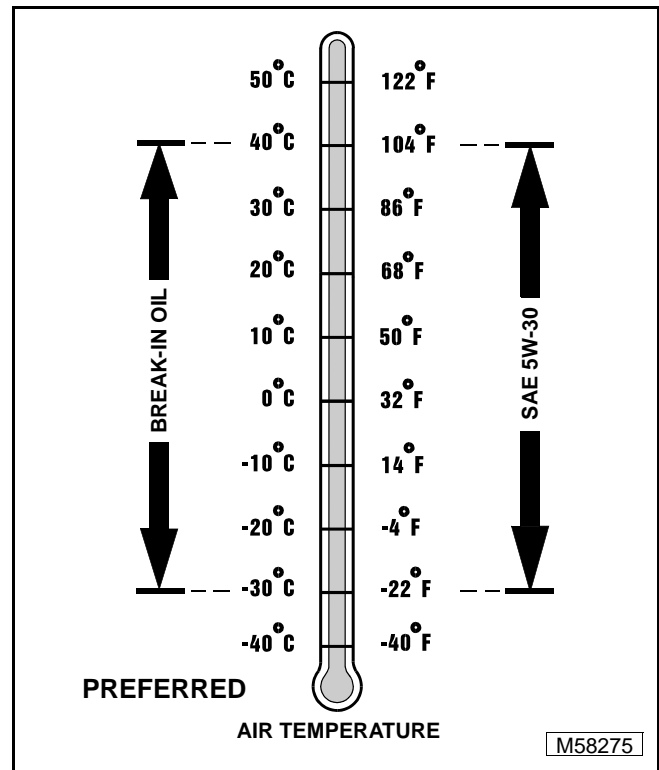

**John Deere Dealers:** You may want to cross-reference the following publications to recommend the proper oil for your customers:

- Module DX, ENOIL4 in JDS-G135;
- Section 530, Lubricants & Hydraulics, of the John Deere Merchandise Sales Guide;
- Lubrication Sales Manual PI7032.

## BREAK-IN 4-CYCLE GASOLINE ENGINE OIL - EUROPE



**IMPORTANT:** ONLY use a quality break-in oil in rebuilt or remanufactured engines for the first 5 hours (maximum) of operation. DO NOT use oils with heavier viscosity weights than SAE 5W-30 or oils meeting CCMC Specification G5—these oils will not allow rebuilt or remanufactured engines to break-in properly.

The following John Deere oil is **PREFERRED**:

- **BREAK-IN ENGINE OIL.**

John Deere **BREAK-IN ENGINE OIL** is formulated with special additives for aluminum and cast iron type engines to allow the power cylinder components (pistons, rings, and liners as well) to “wear-in” while protecting other engine components, valve train and gears, from abnormal wear. Engine rebuild instructions should be followed closely to determine if special requirements are necessary.

John Deere **BREAK-IN ENGINE OIL** is also recommended for non-John Deere engines, both aluminum and cast iron types.

The following John Deere oil is **also recommended** as a break-in engine oil:

- **TORQ-GARD SUPREME®—SAE 5W-30.**

If the above recommended John Deere oils are not available, use a break-in engine oil meeting the following specification during the first 5 hours (maximum) of operation:

- SAE 5W-30—CCMC Specification G4 or higher.

**IMPORTANT:** After the break-in period, use the John Deere oil that is specified for this engine.

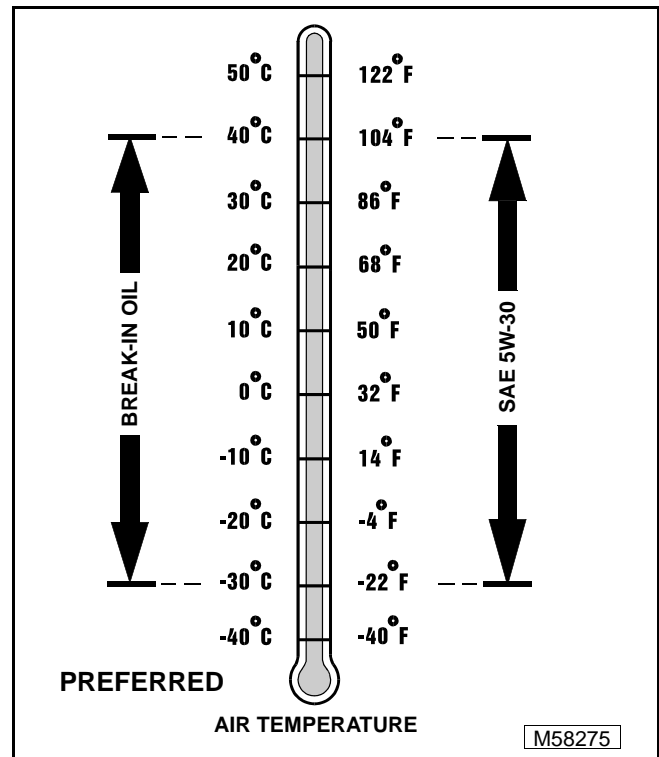

**John Deere Dealers:** You may want to cross-reference the following publications to recommend the proper oil for your customers:

- Module DX, ENOIL4 in JDS-G135;
- Section 530, Lubricants & Hydraulics, of the John Deere Merchandise Sales Guide.

## GEAR CASE OIL - NORTH AMERICA

Use the appropriate oil viscosity based on the air temperature ranges. Operating outside of these recommended oil air temperature ranges may cause premature gear case failure.

**IMPORTANT: ONLY use a quality oil in this gear case. DO NOT mix any other oils in this gear case. DO NOT use BIO-HY-GARD® in this gear case.**

The following John Deere gear case oil is **PREFERRED**:

- **GL-5 GEAR LUBRICANT®—SAE 80W-90.**

The following John Deere gear case oil is **also recommended** if above preferred oil is not available:

- **GL-5 GEAR LUBRICANT®—SAE 85W-140.**

Other gear case oils may be used if above recommended John Deere gear case oils are not available, provided they meet the following specification:

- API Service Classification GL-5.

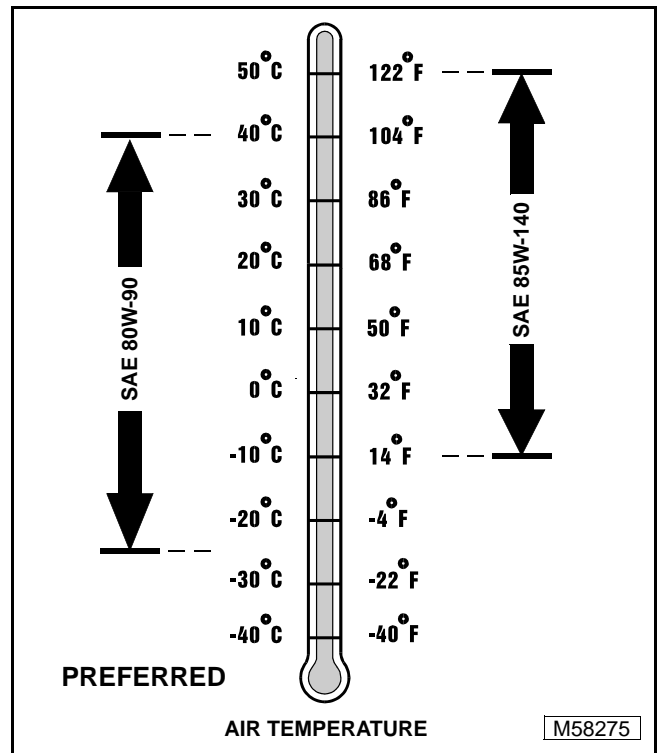

**John Deere Dealers:** You may want to cross-reference the following publications to recommend the proper oil for your customers:

- Module DX, GEOIL in JDS-G135;
- Section 530, Lubricants & Hydraulics, of the John Deere Merchandise Sales Guide;
- Lubrication Sales Manual PI7032.

### GEAR CASE OIL - EUROPE

Use the appropriate oil viscosity based on the air temperature ranges. Operating outside of these recommended oil air temperature ranges may cause premature gear case failure.



**IMPORTANT: ONLY use a quality oil in this gear case. DO NOT mix any other oils in this gear case. DO NOT use BIO-HY-GARD® in this gear case.**

The following John Deere gear case oil is **PREFERRED**:

- **EXTREME-GARD™—SAE 80W-90.**

The following John Deere gear case oil is **also recommended** if above preferred oil is not available:

- **EXTREME-GARD™—SAE 85W-140.**

Other gear case oils may be used if above recommended John Deere gear case oils are not available, provided they meet the following specification:

- API Service Classification GL-5.

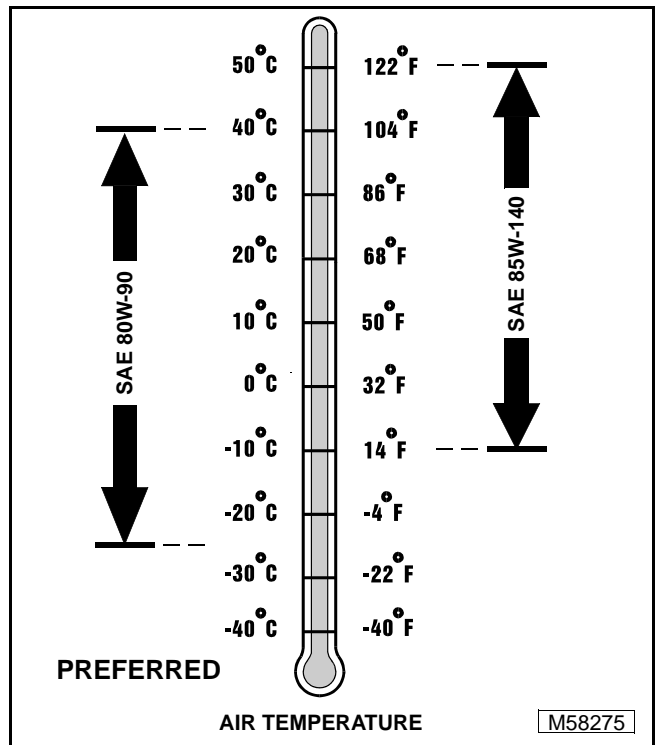

**John Deere Dealers:** You may want to cross-reference the following publications to recommend the proper oil for your customers:

- Module DX, GEOIL in JDS-G135;
- Section 530, Lubricants & Hydraulics, of the John Deere Merchandise Sales Guide.

## GEAR TRANSMISSION GREASE - NORTH AMERICA

Use the following gear grease based on the air temperature range. Operating outside of the recommended grease air temperature range may cause premature gear transmission failure.

**IMPORTANT: ONLY use a quality gear grease in this transmission. DO NOT mix any other greases in this transmission. DO NOT use any BIO-GREASE in this transmission.**

The following John Deere gear grease is **PREFERRED**:

- **NON-CLAY HIGH-TEMPERATURE EP GREASE®**—JDM J13E4, NLGI Grade 2.

Other greases may be used if above preferred John Deere grease is not available, provided they meet the following specification:

- John Deere Standard JDM J13E4, NLGI Grade 2.

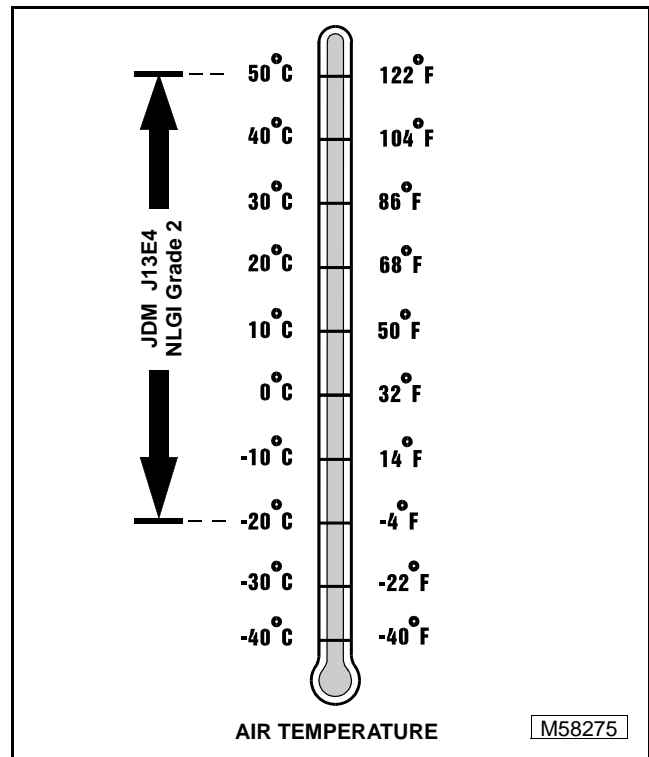

**John Deere Dealers:** You may want to cross-reference the following publications to recommend the proper grease for your customers:

- Module DX,GREA1 in JDS-G135;
- Section 530, Lubricants & Hydraulics, of the John Deere Merchandise Sales Guide;
- Lubrication Sales Manual PI7032.

## GEAR TRANSMISSION GREASE - EUROPE

Use the following gear grease based on the air temperature range. Operating outside of the recommended grease air temperature range may cause premature gear transmission failure.

**IMPORTANT: ONLY use a quality gear grease in this transmission. DO NOT mix any other greases in this transmission. DO NOT use any BIO-GREASE in this transmission.**

The following John Deere gear grease is **PREFERRED**:

- **GREASE-GARD™—JDM J13E4, NLGI Grade 2.**

Other gear greases may be used if above recommended John Deere gear grease is not available, provided they meet the following specification:

- John Deere Standard JDM J13E4, NLGI Grade 2.

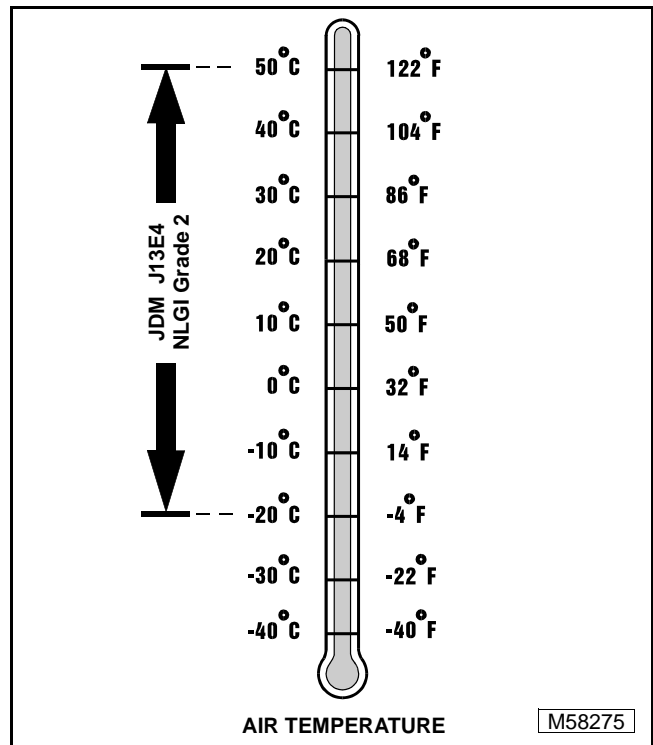

**John Deere Dealers:** You may want to cross-reference the following publications to recommend the proper grease for your customers:

- Module DX,GREA1 in JDS-G135;
- Section 530, Lubricants & Hydraulics, of the John Deere Merchandise Sales Guide.

## GREASE SPECIFICATIONS

### GREASE - NORTH AMERICA

Use the following grease based on the air temperature range. Operating outside of the recommended grease air temperature range may cause premature failures.

**IMPORTANT: ONLY use a quality grease in this application. DO NOT mix any other greases in this application. DO NOT use any BIO-GREASE in this application.**

The following John Deere grease is **PREFERRED**:

- **NON-CLAY HIGH-TEMPERATURE EP GREASE®—JDM J13E4, NLGI Grade 2.**

Other greases may be used if above preferred John Deere grease is not available, provided they meet the following specification:

- John Deere Standard JDM J13E4, NLGI Grade 2.

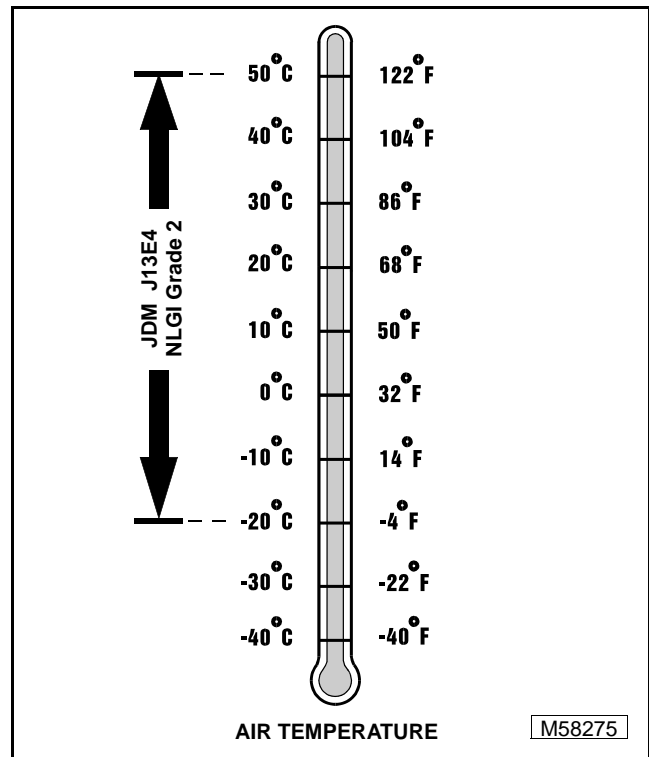

**John Deere Dealers:** You may want to cross-reference the following publications to recommend the proper grease for your customers:

- Module DX, GREA1 in JDS-G135;
- Section 530, Lubricants & Hydraulics, of the John Deere Merchandise Sales Guide;
- Lubrication Sales Manual PI7032.

### GREASE - EUROPE

Use the following grease based on the air temperature range. Operating outside of the recommended grease air temperature range may cause premature failures.



**IMPORTANT:** ONLY use a quality grease in this application. DO NOT mix any other greases in this application. DO NOT use any BIO-GREASE in this application.

The following John Deere grease is **PREFERRED**:

- **GREASE-GARD™—JDM J13E4, NLGI Grade 2.**

Other greases may be used if above preferred John Deere grease is not available, provided they meet the following specification:

- John Deere Standard JDM J13E4, NLGI Grade 2.

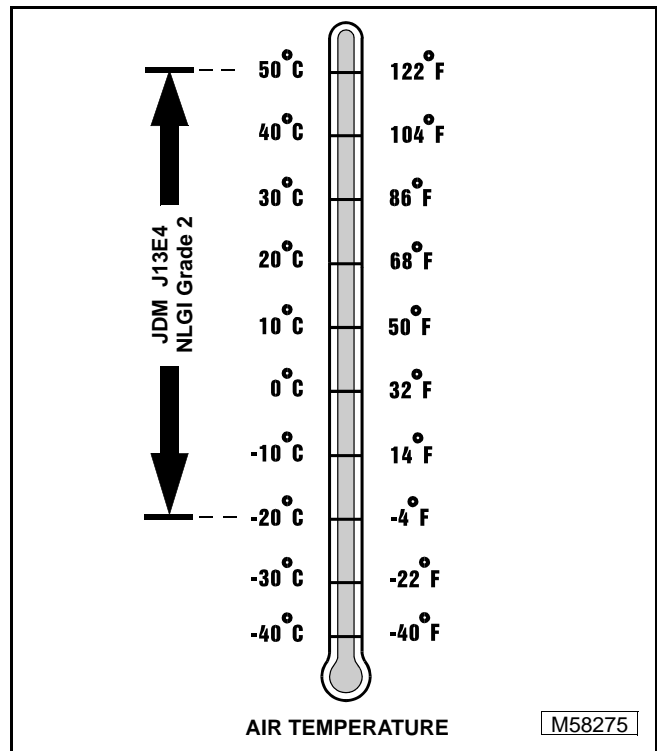

**John Deere Dealers:** You may want to cross-reference the following publications to recommend the proper grease for your customers:

- Module DX,GREA1 in JDS-G135;
- Section 530, Lubricants & Hydraulics, of the John Deere Merchandise Sales Guide.

## ALTERNATIVE LUBRICANTS

### North America—

Conditions in certain geographical areas outside the United States and Canada may require different lubricant recommendations than the ones printed in this technical manual or the operator's manual. Consult with your John Deere Dealer, or Sales Branch, to obtain the alternative lubricant recommendations.

**IMPORTANT: Use of alternative lubricants could cause reduced life of the component.**

If alternative lubricants are to be used, it is recommended that the factory fill be thoroughly removed before switching to any alternative lubricant.

## SYNTHETIC LUBRICANTS

### North America—

Synthetic lubricants may be used in John Deere equipment if they meet the applicable performance requirements (industry classification and/or military specification) as shown in this manual.

The recommended air temperature limits and service or lubricant change intervals should be maintained as shown in the operator's manual, unless otherwise stated on lubricant label.

Avoid mixing different brands, grades, or types of oil. Oil manufacturers blend additives in their oils to meet certain specifications and performance requirements. Mixing different oils can interfere with the proper functioning of these additives and degrade lubricant performance.

## LUBRICANT STORAGE

### North America—

All machines operate at top efficiency only when clean lubricants are used. Use clean storage containers to handle all lubricants. Store them in an area protected from dust, moisture, and other contamination. Store drums on their sides. Make sure all containers are properly marked as to their contents. Dispose of all old, used containers and their contents properly.

## MIXING OF LUBRICANTS

### North America—

In general, avoid mixing different brands or types of lubricants. Manufacturers blend additives in their lubricants to meet certain specifications and performance requirements. Mixing different lubricants can interfere with the proper functioning of these additives and lubricant properties which will downgrade their intended specified performance.



## OIL FILTERS

### North America—

**IMPORTANT: Filtration of oils is critical to proper lubrication performance. Always change filters regularly.**

The following John Deere oil filters are PREFERRED:

- **AUTOMOTIVE AND LIGHT TRUCK ENGINE OIL FILTERS.**

Most John Deere filters contain pressure relief and anti-drainback valves for better engine protection.

Other oil filters may be used if above recommended John Deere oil filters are not available, provided they meet the following specification:

- **ASTB Tested In Accordance With SAE J806.**

**John Deere Dealers:** You may want to cross-reference the following publications to recommend the proper oil filter for your customers:

- **Module DX,FILT in JDS-G135;**
- **Section 540, Lubricants & Hydraulics, of the John Deere Merchandise Sales Guide;**
- **Lawn & Grounds Care Tune-Up Guide PI672.**

## ALTERNATIVE LUBRICANTS

### Europe—



Conditions in certain geographical areas outside the United States and Canada may require different lubricant recommendations than the ones printed in this technical manual or the operator's manual. Consult with your John Deere Dealer, or Sales Branch, to obtain the alternative lubricant recommendations.

**IMPORTANT: Use of alternative lubricants could cause reduced life of the component.**

If alternative lubricants are to be used, it is recommended that the factory fill be thoroughly removed before switching to any alternative lubricant.

## SYNTHETIC LUBRICANTS

### Europe—

Synthetic lubricants may be used in John Deere equipment if they meet the applicable performance requirements (industry classification and/or military specification) as shown in this manual.

The recommended air temperature limits and service or lubricant change intervals should be maintained as shown in the operator's manual, unless otherwise stated on lubricant label.

Avoid mixing different brands, grades, or types of oil. Oil manufacturers blend additives in their oils to meet certain specifications and performance requirements. Mixing different oils can interfere with the proper functioning of these additives and degrade lubricant performance.

## LUBRICANT STORAGE

### Europe—

All machines operate at top efficiency only when clean lubricants are used. Use clean storage containers to handle all lubricants. Store them in an area protected from dust, moisture, and other contamination. Store drums on their sides. Make sure all containers are properly marked as to their contents. Dispose of all old, used containers and their contents properly.

## MIXING OF LUBRICANTS

### Europe—

In general, avoid mixing different brands or types of lubricants. Manufacturers blend additives in their lubricants to meet certain specifications and performance requirements. Mixing different lubricants can interfere with the proper functioning of these additives and lubricant properties which will downgrade their intended specified performance.

## OIL FILTERS

### Europe—

**IMPORTANT: Filtration of oils is critical to proper lubrication performance. Always change filters regularly.**

The following John Deere oil filters are PREFERRED:

- **AUTOMOTIVE AND LIGHT TRUCK ENGINE OIL FILTERS.**

Most John Deere filters contain pressure relief and anti-drainback valves for better engine protection.

Other oil filters may be used if above recommended John Deere oil filters are not available, provided they meet the following specification:

- **ASTB Tested In Accordance With SAE J806.**

**John Deere Dealers:** You may want to cross-reference the following publications to recommend the proper oil filter for your customers:

- **Module DX,FILT in JDS-G135;**
- **Section 540, Lubricants & Hydraulics, of the John Deere Merchandise Sales Guide;**
- **Lawn & Grounds Care Tune-Up Guide PI672.**

## COOLANT SPECIFICATIONS

### DIESEL AND GASOLINE ENGINE COOLANT - NORTH AMERICA

The engine cooling system when filled with a proper dilution mixture of anti-freeze and deionized or distilled water provides year-round protection against corrosion, cylinder or liner pitting, and winter freeze protection down to  $-37^{\circ}\text{C}$  ( $-34^{\circ}\text{F}$ ).

The following John Deere coolant is **PREFERRED**:

- **PRE-DILUTED DIESEL ENGINE ANTI-FREEZE/ SUMMER COOLANT™ (TY16036).**

This coolant satisfies specifications for “Automobile and Light Duty Engine Service” and is safe for use in John Deere Lawn and Grounds Care/Golf and Turf Division equipment, including aluminum block gasoline engines and cooling systems.

The above preferred pre-diluted anti-freeze provides:

- adequate heat transfer
- corrosion-resistant chemicals for the cooling system
- compatibility with cooling system hose and seal material
- protection during extreme cold and extreme hot weather operations
- chemically pure water for better service life
- compliance with ASTM D4656 (JDM H24C2) specifications

If above preferred pre-diluted coolant is not available, the following John Deere concentrate is **recommended**:

- **DIESEL ENGINE ANTI-FREEZE/SUMMER COOLANT CONCENTRATE™ (TY16034).**

If either of above recommended engine coolants are available use any Automobile and Light Duty Engine Service **ethylene glycol base coolant**, meeting the following specification:

- ASTM D3306 (JDM H24C1).

Read container label completely before using and follow instructions as stated.

**IMPORTANT:** To prevent engine damage, **DO NOT** use pure anti-freeze or less than a 50% anti-freeze mixture in the cooling system. **DO NOT** mix or add any additives/conditioners to the cooling system in Lawn and Grounds Care/Golf and Turf Division equipment. Water used to dilute engine coolant concentrate must be of high quality—clean, clear, potable water (low in chloride and hardness—Table 1) is generally acceptable. **DO NOT** use salt water. Deionized or distilled water is ideal to use. Coolant that is not mixed to these specified levels and water purity can cause excessive scale, sludge deposits, and increased corrosion potential.



#### Water Quality

Property	Requirements
Total Solids, Maximum	340 ppm (20 grns/gal)
Total Hardness, Max.	170 ppm (10 grns/gal)
Chloride (as Cl), Max.	40 ppm (2.5 grns/gal)
Sulfate (as $\text{SO}_4$ ), Max.	100 ppm (5.8 grns/gal)

Mix 50 percent anti-freeze concentrate with 50 percent distilled or deionized water. This mixture and the pre-diluted mixture (TY16036) will protect the cooling system down to  $-37^{\circ}\text{C}$  ( $-34^{\circ}\text{F}$ ) and up to  $108^{\circ}\text{C}$  ( $226^{\circ}\text{F}$ ).

Certain geographical areas may require lower air temperature protection. See the label on your anti-freeze container or consult your John Deere dealer to obtain the latest information and recommendations.

### DIESEL AND GASOLINE ENGINE COOLANT DRAIN INTERVAL - NORTH AMERICA

When using **John Deere Pre-Diluted (TY16036)** Automobile and Light Duty Engine Service coolants, drain and flush the cooling system and refill with fresh coolant mixture every **36 months or 3,000 hours** of operation, whichever comes first.

When using **John Deere Concentrate (TY16034)** Automobile and Light Duty Engine Service coolants, drain and flush the cooling system and refill with fresh coolant mixture every **24 months or 2,000 hours** of operation, whichever comes first.

If above John Deere Automobile and Light Duty Engine Service coolants **are not** being used; drain, flush, and refill the cooling system according to instructions found on product container or in equipment operator's manual or technical manual.

## GASOLINE ENGINE COOLANT - EUROPE

The engine cooling system when filled with a proper dilution mixture of anti-freeze and deionized or distilled water provides year-round protection against corrosion, cylinder or liner pitting, and winter freeze protection down to  $-37^{\circ}\text{C}$  ( $-34^{\circ}\text{F}$ ).

**ONLY** use a quality Automobile and Light Duty Engine Service ethylene glycol base coolant, meeting the following specification:

- ASTM D3306 (JDM H24C1).

Read container label completely before using and follow instructions as stated.

**IMPORTANT:** To prevent engine damage, **DO NOT** use pure anti-freeze or less than a 50% anti-freeze mixture in the cooling system. **DO NOT** mix or add any additives/conditioners to the cooling system in Lawn and Grounds Care/Golf and Turf Division equipment. Water used to dilute engine coolant concentrate must be of high quality—clean, clear, potable water (low in chloride and hardness—Table 1) is generally acceptable. **DO NOT** use salt water. Deionized or distilled water is best to use. Coolant that is not mixed to these specified levels and water purity can cause excessive scale, sludge deposits, and increased corrosion potential.

### Water Quality

Property	Requirements
Total Solids, Maximum	340 ppm (20 grns/gal)
Total Hardness, Max.	170 ppm (10 grns/gal)
Chloride (as Cl), Max.	40 ppm (2.5 grns/gal)
Sulfate (as $\text{SO}_4$ ), Max.	100 ppm (5.8 grns/gal)

Mix 50 percent anti-freeze concentrate with 50 percent distilled or deionized water. This mixture will protect the cooling system down to  $-37^{\circ}\text{C}$  ( $-34^{\circ}\text{F}$ ) and up to  $108^{\circ}\text{C}$  ( $226^{\circ}\text{F}$ ).

Certain geographical areas may require lower air temperature protection. See the label on your anti-freeze container or consult your John Deere dealer to obtain the latest information and recommendations.

## GASOLINE ENGINE COOLANT DRAIN INTERVAL - EUROPE

If a quality Automobile and Light Duty Engine Service ethylene glycol base coolant is being used, drain and flush the cooling system and refill with fresh coolant mixture every **24 months or 2,000 hours** of operation, whichever comes first.

If a quality Automobile and Light Duty Engine Service coolant **is not** being used; drain, flush, and refill the cooling system according to instructions found on product container or in equipment operator's manual or technical manual.

## SERIAL NUMBER LOCATIONS

### SERIAL NUMBERS

When working on machines or components that are covered by warranty, it is **IMPORTANT** that you include the machine's Product Identification Number and the component serial number on the warranty claim form.

The locations of component serial number plates are shown below.

### LOCATIONS

#### PRODUCT IDENTIFICATION NUMBER LOCATION



The product identification number (A) is located on the left rear corner of the tractor frame.

#### ENGINE SERIAL NUMBER LOCATION



The engine serial number is located on the right side of the blower housing.

#### HYDROSTATIC TRANSMISSION SERIAL NUMBER LOCATION - 245/265/285/320

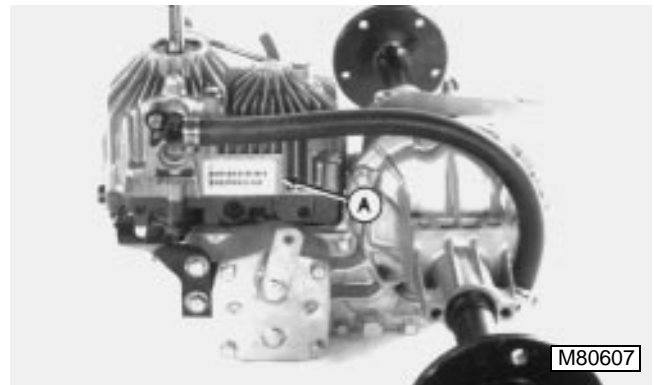

The hydrostatic transmission serial number (A) is located on the left side of the transmission.

#### HYDRAULIC LIFT VALVE SERIAL NUMBER LOCATION - 320

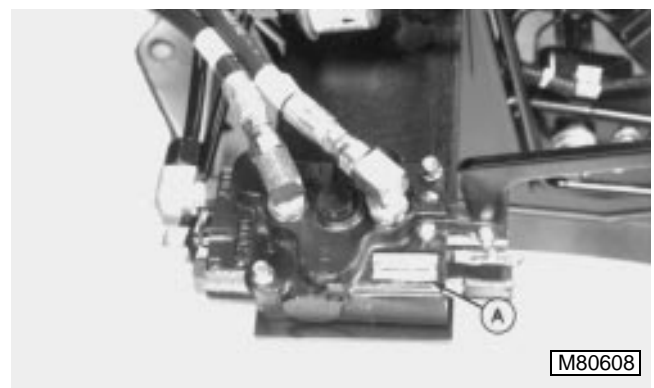

*NOTE: Platform removed for clarity.*

The hydraulic lift valve serial number (A) can be read when lift lever boot is removed. The lift lever is located on the right side of the tractor.

## OPERATIONAL CHECKOUT PROCEDURE

### BEFORE YOU START



This operational diagnostics procedure is designed for you to perform a quick check of the machine in a step-by-step method.

We recommend you perform these checks of the entire machine. These checks refer you to a specific system on the machine for a more detailed step-by-step method of resolving machine problems. These procedure also provide you with a method to evaluate trade-in equipment and perform an annual checkout.

A large majority of typical machine problems can be resolved using operational diagnostics with your senses of look, listen and feel.

Perform these checks on a level surface. No special tools or equipment are required.

When performing the test or check, be sure to set your machine up to the test conditions listed and follow the sequence carefully. The paragraphs marked "Normal" give the specification or condition that should be obtained when performing the test or check. If the results are not normal, go to the section indicated to correct the not normal condition.

Do the entire procedure before continuing on to another section and corrections of the indicated problem. Once the machine checkout is complete, turn to the appropriate sections in this manual.

## BRAKE PEDAL LOCK CHECK

### Conditions:

- Operator on seat.

### Procedures:



M70812

- Move brake pedal lock lever out of UNLOCK detent into LOCK position.



M70813

- GEAR TRACTORS: Depress both the brake and clutch pedals, fully.
- HYDROSTATIC TRACTORS: Depress brake pedals, fully.

### Normal:

- Pedal(s) MUST stay depressed (LOCKED).

### Procedure:



M70821

- Pull brake lock lever up into UNLOCK position. Depress pedal(s) fully and release slowly.

### Normal:

- Pedal(s) MUST return to normal position.

### Not Normal:

- GO TO SECTION 8 OR 9.

## INDICATOR LAMP CHECK - ENGINE OFF

### Conditions:

- Park brake LOCKED.
- Transmission in NEUTRAL.
- PTO switch OFF.

### Procedures:

- Turn key switch ON.

### Normal:



M70814

- Oil pressure lamp (not on 240 or 245 Tractors) MUST be ON.
- Battery discharge lamp MUST be ON.
- Low fuel lamp will come ON only if fuel level is low.
- Coolant temperature lamp (285 and 320 Tractor only) MUST be OFF.
- Hour meter (optional on 240 Tractor) MUST be clicking.

### Not Normal:

- GO TO SECTION 7.

## TRANSMISSION NEUTRAL START CHECK

### Conditions:



# CAUTION

Be aware that if neutral start circuit is defective, tractor will start and move forward. Make sure no persons and/or objects are near the tractor.

- Operator on seat.
- PTO switch OFF.

### Procedures:



M70815

- Put gear lever in first gear, or hydrostatic lever in slow forward.
- Turn key switch to START.

### Normal:

- Starter MUST NOT crank engine.

### Not Normal:

- GO TO SECTION 7.

**PTO/SAFETY START CHECK**

Procedure:



**CAUTION**

Be aware that if PTO neutral start circuit is defective, tractor will start and PTO will engage immediately. Make sure no persons and/or objects are near the attachment.

**Conditions:**

- Operator on seat.
- Brake pedal LOCKED.
- Transmission in NEUTRAL.

**Procedures:**



M70816

- Turn PTO switch ON.
- Turn key switch to START.

**Normal:**

- Starter MUST NOT crank engine.

**Not Normal:**

- GO TO SECTION 7.

**STARTING CIRCUIT CHECK - HYDROSTATIC TRACTORS**

*NOTE: Gear tractors GO TO NEXT PROCEDURE.*

**Conditions:**

- Operator on seat.
- Transmission in neutral.
- Brake pedal LOCKED.
- PTO switch OFF.



M70820

- Turn key switch to START.

**Normal:**

- Starter MUST crank engine. Engine MUST start.

**Not Normal:**

- GO TO SECTION 7.

**STARTING CIRCUIT CHECK - GEAR TRACTORS**

**Conditions:**

- Operator on seat.
- Clutch and park brake LOCKED.
- Transmission in NEUTRAL.
- PTO switch OFF.

**Procedure:**



M70820

- Turn key switch to START.

**Normal:**

- Starter MUST crank engine. Engine MUST start.

**Not Normal:**

- GO TO SECTION 7.

## INDICATOR LAMP CHECK - ENGINE RUNNING

### Conditions:

- Operator on seat.
- Park brake LOCKED.
- Transmission in NEUTRAL.
- PTO switch OFF.

### Procedure:

- Run engine at FULL throttle.

### Normal:



M70817

- Oil pressure lamp (not on 240 or 245 Tractors) MUST be OFF.
- Battery discharge lamp MUST be OFF.
- Low fuel lamp will only come ON if fuel level is low.
- Coolant temperature lamp (285 and 320 Tractors only) MUST be OFF.
- Hour meter (optional on 240 Tractors) MUST be clicking.

### Not Normal:

- GO TO SECTION 7.

## THROTTLE AND CHOKE LEVER CHECK - ENGINE RUNNING

### Conditions:

- Operator on seat.
- Park brake LOCKED.
- Transmission in NEUTRAL.
- PTO switch OFF.

### Procedures:

START engine.



M70818

- Move throttle lever from SLOW TO FAST to SLOW idle.

### Normal:

- Lever MUST contact stop at FAST and SLOW idle positions.
- Engine MUST accelerate and decelerate SMOOTHLY without hesitation.

### Procedure:



M70822

- Move throttle into CHOKE position (not on 285 F.I. Tractors), then return to FAST idle position.

### Normal:

- Engine MUST falter, then resume FAST speed.

### Not Normal:

- ALL TRACTORS EXCEPT 285 F.I. TRACTOR GO TO SECTION 3 AND 4.
- 285 F.I. TRACTOR GO TO SECTION 5.



**Suggest:**

**If the above button click is invalid.**

**Please download this document**

**first, and then click the above link**

**to download the complete manual.**

**Thank you so much for reading**

## PTO CLUTCH CHECK

**Conditions:**

- Operator on seat.
- Park brake LOCKED.
- Transmission in NEUTRAL.
- Engine OFF.

**Procedures:**



- Turn key switch to ON position ONLY.
- Turn PTO switch ON.

**Normal:**

- PTO clutch MUST click once.

**Not Normal:**

- GO TO SECTION 7.

## SEAT SWITCH CHECK - PTO AND IGNITION

**⚠ CAUTION**

Be aware that if a PTO driven attachment is installed and there are no faulty components in the PTO and safety start circuits, the attachment **WILL ENGAGE** when PTO switch is turned ON. Make sure no persons and/or objects are near the attachment.

**Conditions:**

- Operator on seat.
- Park brake LOCKED.
- Transmission in NEUTRAL.

**Procedures:**



- Run engine at HALF throttle.
- Turn PTO switch ON.
- Raise OFF seat.

**Normal:**

- Engine MUST STOP.

**Not Normal:**

- GO TO SECTION 7.

## TRANSMISSION FORWARD AND REVERSE CHECK

**⚠ CAUTION**

Perform this check in a large, flat and open area away from people and/or stationary objects or structures.

**Procedures:**

- Run engine at FULL throttle.



- HYDROSTATIC TRACTORS: Slowly move transmission lever through full range of forward and reverse directions.

**<https://www.ebooklibonline.com>**

Hello dear friend!

Thank you very much for reading.

Enter the link into your browser.

The full manual is available for immediate download.

**<https://www.ebooklibonline.com>**