

**JOHN DEERE**  
**WORLDWIDE COMMERCIAL & CONSUMER**  
**EQUIPMENT DIVISION**

---

**Tractor Loader Backhoe**  
**110**

TM1987 JUN02

**TECHNICAL MANUAL**



**JOHN DEERE**

North American Version  
Litho in U.S.A.



# INTRODUCTION

---

## Manual Description

This technical manual is written for an experienced technician and contains sections that are specifically for this product. It is a part of a total product support program.

The manual is organized so that all the information on a particular system is kept together. The order of grouping is as follows:

- Table of Contents
- Specifications and Information
- Identification Numbers
- Tools and Materials
- Component Location
- Schematics and Harnesses
- Theory of Operation
- Operation and Diagnostics
- Diagnostics
- Tests and Adjustments
- Repair
- Other

**NOTE: Depending on the particular section or system being covered, not all of the above groups may be used.**

The bleed tabs for the pages of each section will align with the sections listed on this page. Page numbering is consecutive from the beginning of the Safety section through the last section.

We appreciate your input on this manual. If you find any errors or want to comment on the layout of the manual please contact us.

**Safety**

**Specifications and Information**

**Engine**

**Electrical**

**Power Train**

**Hydraulics**

**Steering**

**Brakes**

**Loader**

**Backhoe**

**Miscellaneous**

All information, illustrations and specifications in this manual are based on the latest information at the time of publication. The right is reserved to make changes at any time without notice.

COPYRIGHT© 2002  
Deere & Co.  
John Deere Worldwide Commercial and  
Consumer Equipment Division  
All rights reserved  
Previous Editions  
COPYRIGHT©

**<https://www.ebooklibonline.com>**

Hello dear friend!

Thank you very much for reading.

Enter the link into your browser.

The full manual is available for immediate download.

**<https://www.ebooklibonline.com>**

# INTRODUCTION

---

---

# SAFETY

## Recognize Safety Information

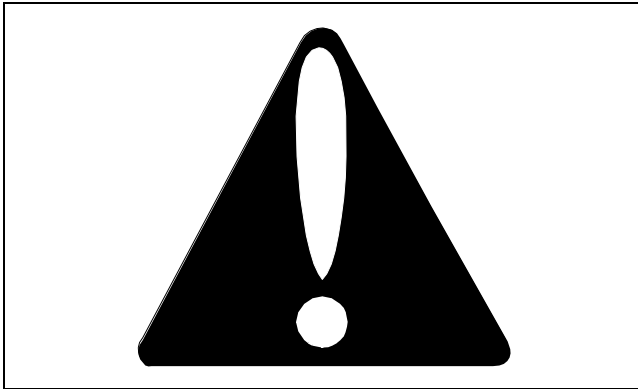

MIF

This is the safety-alert symbol. When you see this symbol on your machine or in this manual, be alert to the potential for personal injury.

Follow recommended precautions and safe servicing practices.

## Understand Signal Words

A signal word - DANGER, WARNING, or CAUTION - is used with the safety-alert symbol. DANGER identifies the most serious hazards.

DANGER or WARNING safety signs are located near specific hazards. General precautions are listed on CAUTION safety signs. CAUTION also calls attention to safety messages in this manual.

## Replace Safety Signs

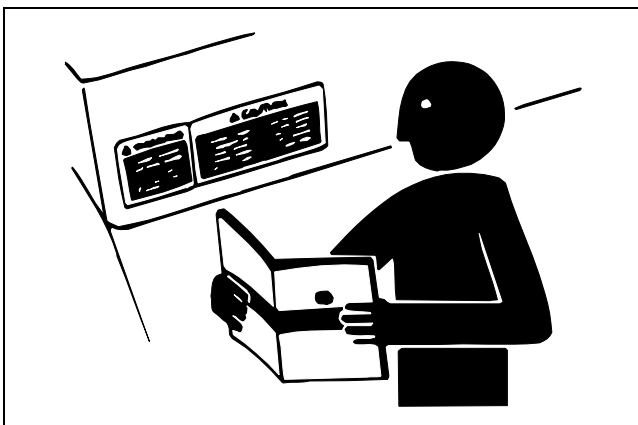

MIF

Replace missing or damaged safety signs. See the machine operator's manual for correct safety sign placement.

## Be Prepared for Emergencies

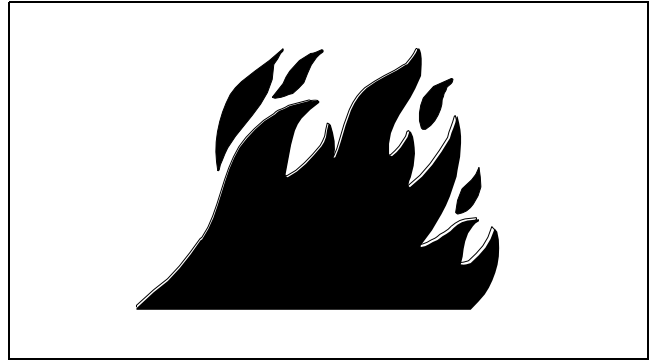

MIF

When you work around fuel, do not smoke or work near heaters or other fire hazards.

Store flammable fluids away from fire hazards. Do not incinerate or puncture pressurized containers.

Make sure machine is clean of trash, grease, and debris.

Do not store oily rags; they can ignite and burn spontaneously.

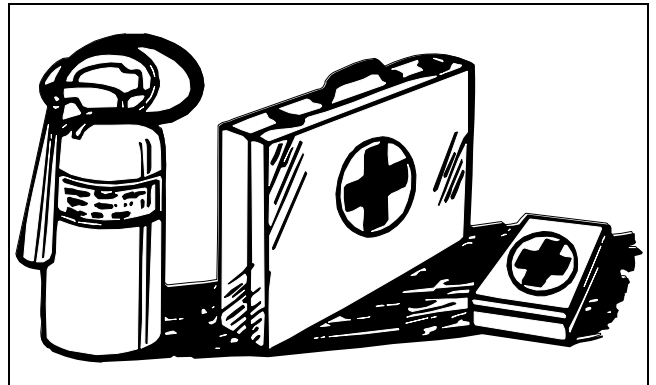

MIF

Be prepared if a fire starts.

Keep a first aid kit and fire extinguisher handy.

Keep emergency numbers for doctors, ambulance service, hospital, and fire department near your telephone.

# SAFETY

## Use Care in Handling and Servicing Batteries

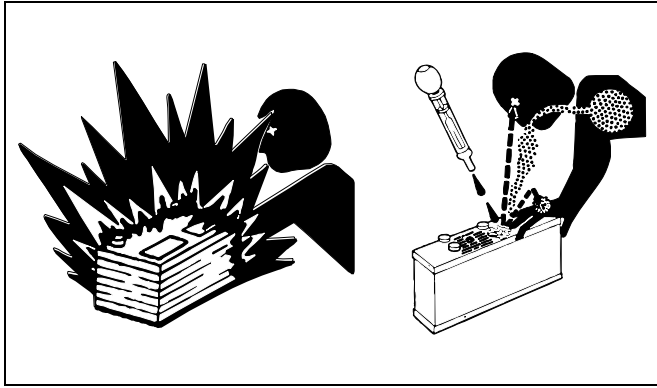

MIF

### Prevent Battery Explosions

- Keep sparks, lighted matches, and open flame away from the top of battery. Battery gas can explode.
- Never check battery charge by placing a metal object across the posts. Use a volt-meter or hydrometer.
- Do not charge a frozen battery; it may explode. Warm battery to 16°C (60°F).

### Prevent Acid Burns

Sulfuric acid in battery electrolyte is poisonous. It is strong enough to burn skin, eat holes in clothing, and cause blindness if splashed into eyes.

#### Avoid acid burns by:

1. Filling batteries in a well-ventilated area.
2. Wearing eye protection and rubber gloves.
3. Avoiding breathing fumes when electrolyte is added.
4. Avoiding spilling or dripping electrolyte.
5. Use proper jump start procedure.

#### If you spill acid on yourself:

1. Flush your skin with water.
2. Apply baking soda or lime to help neutralize the acid.
3. Flush your eyes with water for 10-15 minutes.
4. Get medical attention immediately.

#### If acid is swallowed:

1. Drink large amounts of water or milk.
2. Then drink milk of magnesia, beaten eggs, or vegetable oil.
3. Get medical attention immediately.

## Use Care Around High-Pressure Fluid Lines

### Avoid High-Pressure Fluids

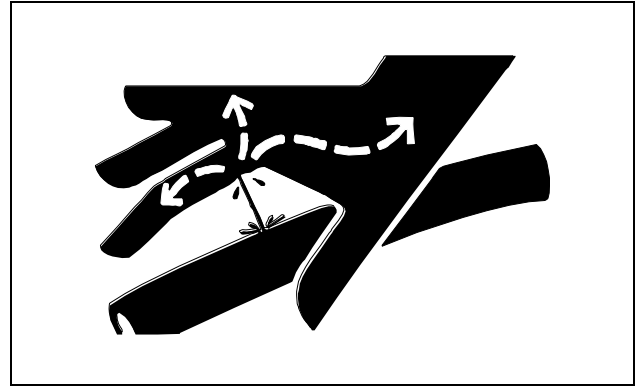

MIF

Escaping fluid under pressure can penetrate the skin causing serious injury.

Avoid injury from escaping fluid under pressure by stopping the engine and relieving pressure in the system before disconnecting or connecting hydraulic or other lines. Tighten all connections before applying pressure.

Search for leaks with a piece of cardboard. Protect hands and body from high pressure fluids.

If an accident occurs, see a doctor immediately. Any fluid injected into the skin must be surgically removed within a few hours or gangrene may result. Doctors unfamiliar with this type of injury should reference a knowledgeable medical source. Such information is available from Deere & Company Medical Department in Moline, Illinois, U.S.A.

### Avoid Heating Near Pressurized Fluid Lines



MIF

Flammable spray can be generated by heating near pressurized fluid lines, resulting in severe burns to yourself and bystanders. Do not heat by welding, soldering, or using a torch near pressurized fluid lines or other flammable materials. Pressurized lines can be accidentally cut when heat goes beyond the immediate flame area.

# SAFETY

## Use Safe Service Procedures

### Wear Protective Clothing

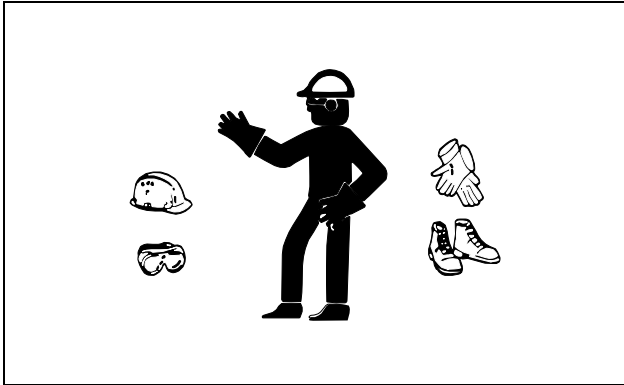

MIF

Wear close fitting clothing and safety equipment appropriate to the job.

Prolonged exposure to loud noise can cause impairment or loss of hearing. Wear a suitable hearing protective device such as earmuffs or earplugs to protect against objectionable or uncomfortable loud noises.

Operating equipment safely requires the full attention of the operator. Do not wear radio or music headphones while operating machine.

### Service Machines Safely

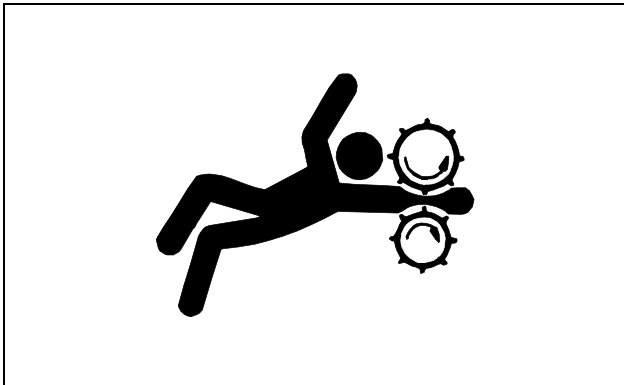

MIF

Tie long hair behind your head. Do not wear a necktie, scarf, loose clothing, or necklace when you work near machine tools or moving parts. If these items were to get caught, severe injury could result.

Remove rings and other jewelry to prevent electrical shorts and entanglement in moving parts.

### Use Proper Tools

Use tools appropriate to the work. Makeshift tools and procedures can create safety hazards. Use power tools only to loosen threaded parts and fasteners. For loosening and tightening hardware, use the correct size tools. **DO NOT** use U.S. measurement tools on metric fasteners.

Avoid bodily injury caused by slipping wrenches. Use only service parts meeting John Deere specifications.

### Park Machine Safely

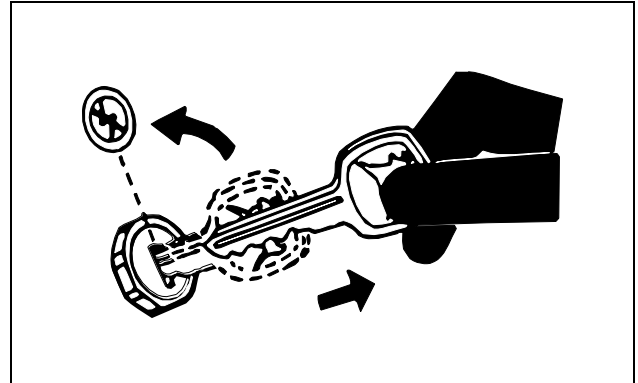

MIF

### Before working on the machine:

1. Lower all equipment to the ground.
2. Stop the engine and remove the key.
3. Disconnect the battery ground strap.
4. Hang a "DO NOT OPERATE" tag in operator station.

### Support Machine Properly and Use Proper Lifting Equipment

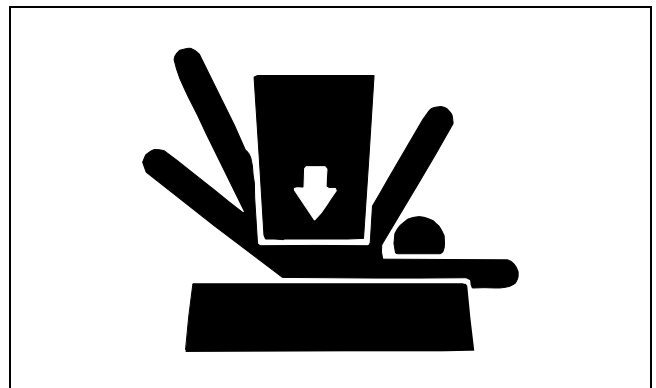

MIF

If you must work on a lifted machine or attachment, securely support the machine or attachment.

Do not support the machine on cinder blocks, hollow tiles, or props that may crumble under continuous load. Do not work under a machine that is supported solely by a jack. Follow recommended procedures in this manual.

Lifting heavy components incorrectly can cause severe injury or machine damage. Follow recommended procedure for removal and installation of components in the manual.

# SAFETY

## Work in Clean Area

### Before starting a job:

1. Clean work area and machine.
2. Make sure you have all necessary tools to do your job.
3. Have the right parts on hand.
4. Read all instructions thoroughly; do not attempt shortcuts.

## Using High Pressure Washers

Directing pressurized water at electronic/electrical components or connectors, bearings, hydraulic seals, fuel injection pumps or other sensitive parts and components may cause product malfunctions. Reduce pressure and spray at a 45 to 90 degree angle.

## Illuminate Work Area Safely

Illuminate your work area adequately but safely. Use a portable safety light for working inside or under the machine. Make sure the bulb is enclosed by a wire cage. The hot filament of an accidentally broken bulb can ignite spilled fuel or oil.

## Work in Ventilated Area

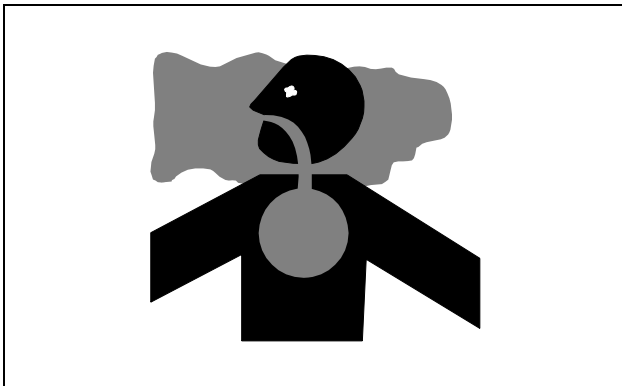

MIF

Engine exhaust fumes can cause sickness or death. If it is necessary to run an engine in an enclosed area, remove the exhaust fumes from the area with an exhaust pipe extension.

If you do not have an exhaust pipe extension, open the doors and get outside air into the area.

### **WARNING: California Proposition 65 Warning**

Diesel engine exhaust and some of its constituents are known to the State of California to cause cancer, birth defects, and other reproductive harm.

Gasoline engine exhaust from this product contains chemicals known to the State of California to cause cancer, birth defects, or other reproductive harm.

## Remove Paint before Welding or Heating

Avoid potentially toxic fumes and dust. Hazardous fumes can be generated when paint is heated by welding, soldering, or using a torch. Do all work outside or in a well-ventilated area. Dispose of paint and solvent properly. Remove paint before welding or heating. If you sand or grind paint, avoid breathing the dust. Wear an approved respirator. If you use solvent or paint stripper, remove stripper with soap and water before welding. Remove solvent or paint stripper containers and other flammable material from area. Allow fumes to disperse at least 15 minutes before welding or heating.

## Avoid Harmful Asbestos Dust

Avoid breathing dust that may be generated when handling components containing asbestos fibers. Inhaled asbestos fibers may cause lung cancer.

Components in products that may contain asbestos fibers are brake pads, brake band and lining assemblies, clutch plates, and some gaskets. The asbestos used in these components is usually found in a resin or sealed in some way. Normal handling is not hazardous as long as airborne dust containing asbestos is not generated.

Avoid creating dust. Never use compressed air for cleaning. Avoid brushing or grinding material containing asbestos. When servicing, wear an approved respirator. A special vacuum cleaner is recommended to clean asbestos. If not available, apply a mist of oil or water on the material containing asbestos. Keep bystanders away from the area.

## Service Tires Safely



MIF

Explosive separation of a tire and rim parts can cause serious injury or death.

Do not attempt to mount a tire unless you have the proper equipment and experience to perform the job. Always maintain the correct tire pressure. Do not inflate the tires above the recommended pressure. Never weld or heat a wheel and tire assembly. The heat can cause an increase in air pressure resulting in a tire explosion. Welding can

# SAFETY

structurally weaken or deform the wheel.

When inflating tires, use a clip-on chuck and extension hose long enough to allow you to stand to one side and NOT in front of or over the tire assembly. Use a safety cage if available.

Check wheels for low pressure, cuts, bubbles, damaged rims or missing lug bolts and nuts.

## Service Cooling System Safely

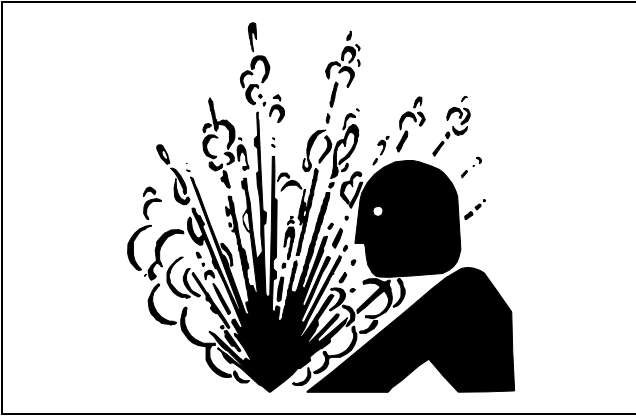

MIF

Explosive release of fluids from pressurized cooling system can cause serious burns.

Shut off machine. Only remove filler cap when cool enough to touch with bare hands. Slowly loosen cap to first stop to relieve pressure before removing completely.

## Handle Chemical Products Safely

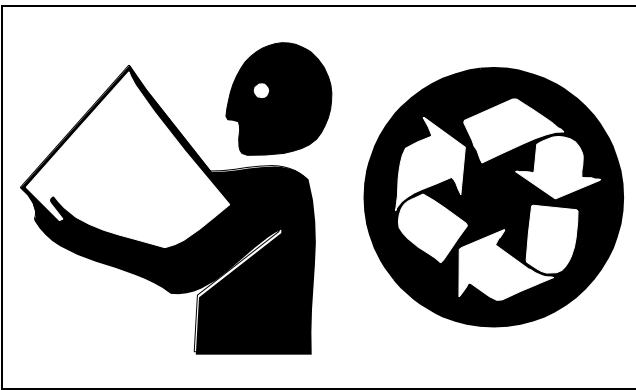

MIF

Direct exposure to hazardous chemicals can cause serious injury. Potentially hazardous chemicals used with John Deere equipment include such items as lubricants, coolants, paints, and adhesives.

A Material Safety Data Sheet (MSDS) provides specific details on chemical products: physical and health hazards, safety procedures, and emergency response techniques. Check the MSDS before you start any job using a

hazardous chemical. That way you will know exactly what the risks are and how to do the job safely. Then follow procedures and recommended equipment.

## Dispose of Waste Properly

Improperly disposing of waste can threaten the environment and ecology. Potentially harmful waste used with John Deere equipment include such items as oil, fuel, coolant, brake fluid, filters, and batteries. Use leakproof containers when draining fluids. Do not use food or beverage containers that may mislead someone into drinking from them. Do not pour waste onto the ground, down a drain, or into any water source. Inquire on the proper way to recycle or dispose of waste from your local environmental or recycling center, or from your John Deere dealer.

## Live with Safety



MIF

Before returning machine to customer, make sure machine is functioning properly, especially the safety systems. Install all guards and shields.

# SAFETY

---

---



# SPECIFICATIONS & INFORMATION TABLE OF CONTENTS

---

## Table of Contents

<b>Specifications</b> .....	<b>9</b>
Metric Fastener Torque Values .....	9
Metric Fastener Torque Values - Grade 7 .....	10
Inch Fastener Torque Values .....	11
Face Seal Fittings with Inch Stud Ends Torque .....	12
Face Seal Fittings with Metric Stud Ends Torque .....	13
O-Ring Face Seal Fittings .....	14
O-Ring Boss Fittings .....	14
Diesel Fuel .....	15
Diesel Fuel Lubricity .....	15
Diesel Fuel Storage .....	15
DIESELSCAN™ Fuel Analysis .....	15
Engine Oil .....	15
Engine Break-in Oil .....	16
OILSCAN®, OILSCAN Plus®, COOLSCAN™, and COOLSCAN PLUS™ .....	17
Alternative Lubricants .....	17
Synthetic Lubricants .....	17
Lubricant Storage .....	17
Mixing of Lubricants .....	17
Chassis Grease .....	18
Transaxle Oil .....	18
Engine Coolant .....	19
Testing Diesel Engine Coolant .....	20
Operating in Warm Temperature Climates .....	20
Flush and Service Cooling System .....	21
Disposing of Coolant .....	21
Engine Coolant Drain Interval .....	22
Machine Product Identification Number .....	22
Engine Serial Number Location .....	22
<b>General Information</b> .....	<b>23</b>
Interlock System .....	23

**SPECIFICATIONS & INFORMATION TABLE OF CONTENTS**

---

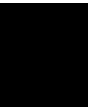

---



# SPECIFICATIONS & INFORMATION SPECIFICATIONS

## Specifications

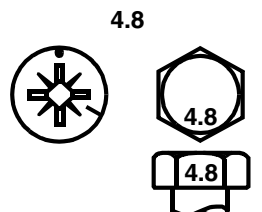
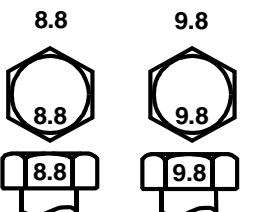
## Metric Fastener Torque Values

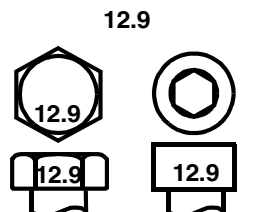
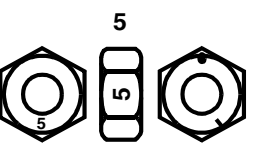
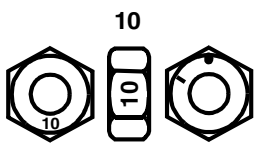
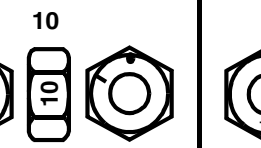
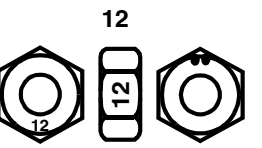
<b>Property Class and Head Markings</b>				
<b>Property Class and Nut Markings</b>				

TS1163

	Class 4.8				Class 8.8 or 9.8				Class 10.9				Class 12.9			
	Lubricated <sup>a</sup>		Dry <sup>a</sup>		Lubricated <sup>a</sup>		Dry <sup>a</sup>		Lubricated <sup>a</sup>		Dry <sup>a</sup>		Lubricated <sup>a</sup>		Dry <sup>a</sup>	
SIZE	N•m	lb-ft	N•m	lb-ft	N•m	lb-ft	N•m	lb-ft	N•m	lb-ft	N•m	lb-ft	N•m	lb-ft	N•m	lb-ft
M6	4.8	3.5	6	4.5	9	6.5	11	8.5	13	9.5	17	12	15	11.5	19	14.5
M8	12	8.5	15	11	22	16	28	20	32	24	40	30	37	28	47	35
M10	23	17	29	21	43	32	55	40	63	47	80	60	75	55	95	70
M12	40	29	50	37	75	55	95	70	110	80	140	105	130	95	165	120
M14	63	47	80	60	120	88	150	110	175	130	225	165	205	150	260	190
M16	100	73	125	92	190	140	240	175	275	200	350	225	320	240	400	300
M18	135	100	175	125	260	195	330	250	375	275	475	350	440	325	560	410
M20	190	140	240	180	375	275	475	350	530	400	675	500	625	460	800	580
M22	260	190	330	250	510	375	650	475	725	540	925	675	850	625	1075	800
M24	330	250	425	310	650	475	825	600	925	675	1150	850	1075	800	1350	1000
M27	490	360	625	450	950	700	1200	875	1350	1000	1700	1250	1600	1150	2000	1500
M30	675	490	850	625	1300	950	1650	1200	1850	1350	2300	1700	2150	1600	2700	2000
M33	900	675	1150	850	1750	1300	2200	1650	2500	1850	3150	2350	2900	2150	3700	2750
M36	1150	850	1450	1075	2250	1650	2850	2100	3200	2350	4050	3000	3750	2750	4750	3500

- DO NOT use these hand torque values if a different torque value or tightening procedure is given for a specific application. Torque values listed are for general use only and include a ± 10% variance factor. Check tightness of fasteners periodically. DO NOT use air powered wrenches.
- Shear bolts are designed to fail under predetermined loads. Always replace shear bolts with identical grade.
- Fasteners should be replaced with the same class. Make sure fastener threads are clean and that you properly start thread engagement. This will prevent them from failing when tightening.

- When bolt and nut combination fasteners are used, torque values should be applied to the **NUT** instead of the bolt head.
  - Tighten toothed or serrated-type lock nuts to the full torque value.
- <sup>a</sup> “Lubricated” means coated with a lubricant such as engine oil, or fasteners with phosphate and oil coatings. “Dry” means plain or zinc plated (yellow dichromate - Specification JDS117) without any lubrication.

Reference: JDS-200

# SPECIFICATIONS & INFORMATION SPECIFICATIONS

---





---

## Metric Fastener Torque Values - Grade 7

Size	Steel or Gray Iron Torque	Aluminum Torque
	N•m (lb-ft)	N•m (lb-ft)
M6	11 (8)	8 (6)
M8	24 (18)	19 (14)
M10	52 (38)	41 (30)
M12	88 (65)	70 (52)
M14	138 (102)	111 (82)
M16	224 (165)	179 (132)

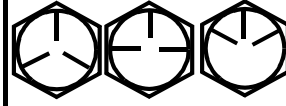
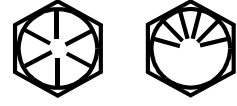
# SPECIFICATIONS & INFORMATION SPECIFICATIONS

## Inch Fastener Torque Values

<b>SAE Grade and Head Markings</b>	1 or 2 <sup>b</sup> No Marks 	5      5.1      5.2 	8      8.2 
<b>SAE Grade and Nut Markings</b>	2 No Marks 	5 	8 

TS1162

SIZE	Grade 1		Grade 2 <sup>b</sup>				Grade 5, 5.1 or 5.2				Grade 8 or 8.2					
	Lubricated <sup>a</sup>		Dry <sup>a</sup>		Lubricated <sup>a</sup>		Dry <sup>a</sup>		Lubricated <sup>a</sup>		Dry <sup>a</sup>		Lubricated <sup>a</sup>		Dry <sup>a</sup>	
	N•m	lb-ft	N•m	lb-ft	N•m	lb-ft	N•m	lb-ft	N•m	lb-ft	N•m	lb-ft	N•m	lb-ft	N•m	lb-ft
1/4	3.7	2.8	4.7	3.5	6	4.5	7.5	5.5	9.5	7	12	9	13.5	10	17	12.5
5/16	7.7	5.5	10	7	12	9	15	11	20	15	25	18	28	21	35	26
3/8	14	10	17	13	22	16	27	20	35	26	44	33	50	36	63	46
7/16	22	16	28	20	35	26	44	32	55	41	70	52	80	58	100	75
1/2	33	25	42	31	53	39	67	50	85	63	110	80	120	90	150	115
9/16	48	36	60	45	75	56	95	70	125	90	155	115	175	130	225	160
5/8	67	50	85	62	105	78	135	100	170	125	215	160	215	160	300	225
3/4	120	87	150	110	190	140	240	175	300	225	375	280	425	310	550	400
7/8	190	140	240	175	190	140	240	175	490	360	625	450	700	500	875	650
1	290	210	360	270	290	210	360	270	725	540	925	675	1050	750	1300	975
1-1/8	470	300	510	375	470	300	510	375	900	675	1150	850	1450	1075	1850	1350
1-1/4	570	425	725	530	570	425	725	530	1300	950	1650	1200	2050	1500	2600	1950
1-3/8	750	550	950	700	750	550	950	700	1700	1250	2150	1550	2700	2000	3400	2550
1-1/2	1000	725	1250	925	990	725	1250	930	2250	1650	2850	2100	3600	2650	4550	3350

- DO NOT use these hand torque values if a different torque value or tightening procedure is given for a specific application. Torque values listed are for general use only and include a ± 10% variance factor. Check tightness of fasteners periodically. DO NOT use air powered wrenches.
- Shear bolts are designed to fail under predetermined loads. Always replace shear bolts with identical grade.
- Fasteners should be replaced with the same class. Make sure fastener threads are clean and that you properly start thread engagement. This will prevent them from failing when tightening.
- When bolt and nut combination fasteners are used, torque values should be applied to the **NUT** instead of

the bolt head.

- Tighten toothed or serrated-type lock nuts to the full torque value.

<sup>a</sup> “Lubricated” means coated with a lubricant such as engine oil, or fasteners with phosphate and oil coatings. “Dry” means plain or zinc plated (yellow dichromate - Specification JDS117) without any lubrication.

<sup>b</sup> “Grade 2” applies for hex cap screws (not hex bolts) up to 152 mm (6 in.) long. “Grade 1” applies for hex cap screws over 152 mm (6 in.) long, and for all other types of bolts and screws of any length.

Reference: JDS-G200

# SPECIFICATIONS & INFORMATION SPECIFICATIONS

## Face Seal Fittings with Inch Stud Ends Torque

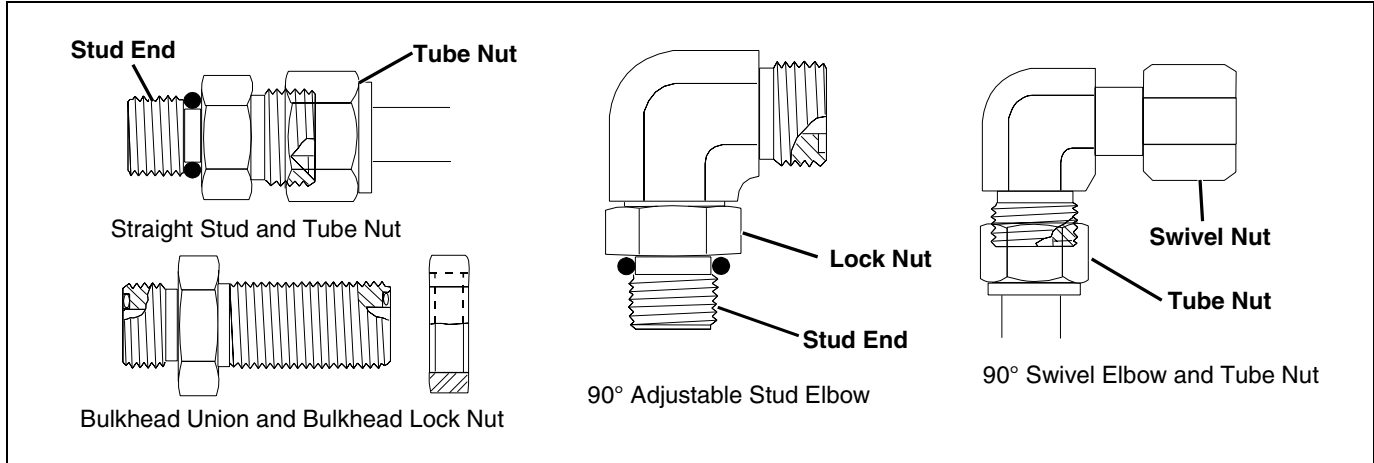

MIF

Nominal Tube OD/Hose ID				Face Seal Tube/Hose End					O-Ring Stud Ends		
Metric Tube OD	Inch Tube OD			Thread Size	Tube Nut/ Swivel Nut Torque		Bulkhead Lock Nut Torque		Thread Size	Straight Fitting or Lock Nut Torque	
	mm	Dash Size	in.		mm	in.	N•m	lb-ft		N•m	lb-ft
	-3	0.188	4.76						3/8-24	8	6
6	-4	0.250	6.35	9/16-18	16	12	12	9	7/16-20	12	9
8	-5	0.312	7.94						1/2-20	16	12
10	-6	0.375	9.52	11/16-16	24	18	24	18	9/16-18	24	18
12	-8	0.500	12.70	13/16-16	50	37	46	34	3/4-16	46	34
16	-10	0.625	15.88	1-14	69	51	62	46	7/8-14	62	46
	-12	0.750	19.05	1-3/16-12	102	75	102	75	1-1/16-12	102	75
22	-14	0.875	22.22	1-3/16-12	102	75	102	75	1-3/16-12	122	90
25	-16	1.000	25.40	1-7/16-12	142	105	142	105	1-5/16-12	142	105
32	-20	1.25	31.75	1-11/16-12	190	140	190	140	1-5/8-12	190	140
38	-24	1.50	38.10	2-12	217	160	217	160	1-7/8-12	217	160

**NOTE: Torque tolerance is +15%, -20%**

# SPECIFICATIONS & INFORMATION SPECIFICATIONS

## Face Seal Fittings with Metric Stud Ends Torque

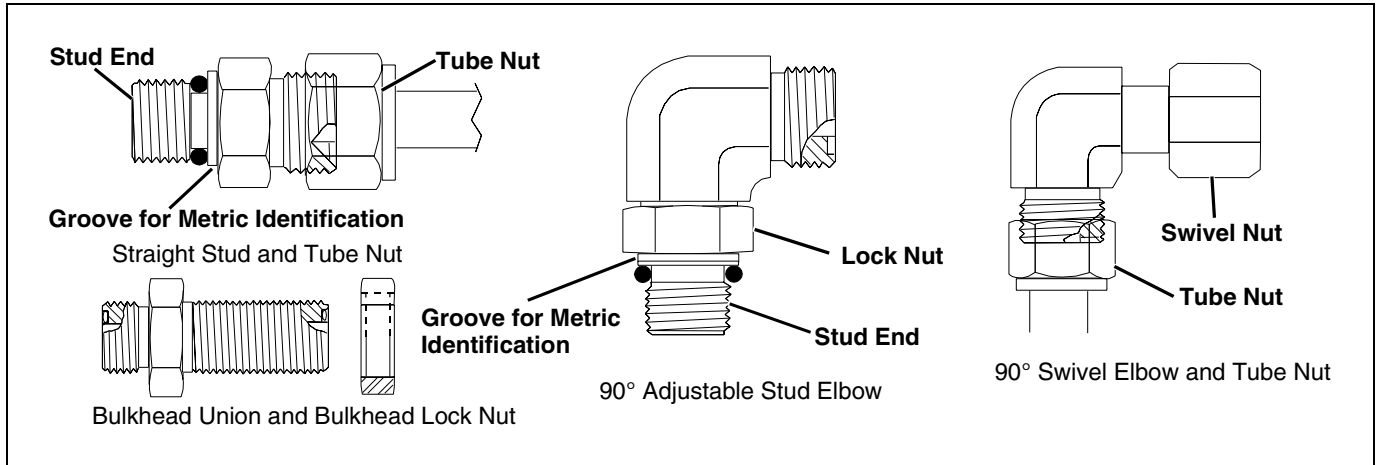

MIF

Nominal Tube OD/Hose ID				Face Seal Tube/Hose End						O-Ring Stud Ends, Straight Fitting or Lock Nut					
Metric Tube OD	Inch Tube OD			Thread Size	Hex Size	Tube Nut/ Swivel Nut Torque		Bulkhead Lock Nut Torque		Thread Size	Hex Size	Steel or Gray Iron Torque		Aluminum Torque	
	mm	Dash Size	in.			mm	in.	mm	N•m			lb-ft	N•m	lb-ft	mm
6	-4	0.250	6.35	9/16-18	17	16	12	12	9	M12X1.5	17	21	15.5	9	6.6
8	-5	0.312	7.94							M14X1.5	19	33	24	15	11
10	-6	0.375	9.52	11/16-16	22	24	18	24	18	M16X1.5	22	41	30	18	13
12	-8	0.500	12.70	13/16-16	24	50	37	46	34	M18X1.5	24	50	37	21	15
16	-10	0.625	15.88	1-14	30	69	51	62	46	M22X1.5	27	69	51	28	21
	-12	0.750	19.05	1-3/16-12	36	102	75	102	75	M27X2	32	102	75	46	34
22	-14	0.875	22.22	1-3/16-12	36	102	75	102	75	M30X2	36				
25	-16	1.000	25.40	1-7/16-12	41	142	105	142	105	M33X2	41	158	116	71	52
28										M38X2	46	176	130	79	58
32	-20	1.25	31.75	1-11/16-12	50	190	140	190	140	M42X2	50	190	140	85	63
38	-24	1.50	38.10	2-12	60	217	160	217	160	M48X2	55	217	160	98	72

**NOTE: Torque tolerance is +15%, -20%**

# SPECIFICATIONS & INFORMATION SPECIFICATIONS

## O-Ring Face Seal Fittings

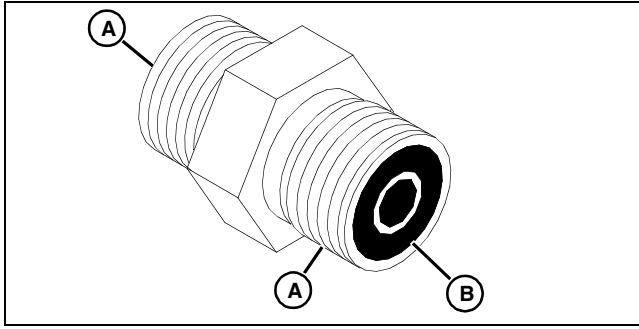

1. Inspect the fitting sealing surfaces (A). They must be free of dirt or defects.
2. Inspect the O-ring (B). It must be free of damage or defects.
3. Lubricate O-rings and install into groove using petroleum jelly to hold in place.
4. Push O-ring into the groove with plenty of petroleum jelly so O-ring is not displaced during assembly.
5. Index angle fittings and tighten by hand-pressing joint together to ensure O-ring remains in place.

**IMPORTANT: Avoid damage! DO NOT allow hoses to twist when tightening fittings. Use two wrenches to tighten hose connections; one to hold the hose, and the other to tighten the swivel fitting.**

6. Tighten fitting or nut to torque value shown on the chart per dash size stamped on the fitting.

## O-Ring Boss Fittings

1. Inspect O-ring boss seat. It must be free of dirt and defects. If repeated leaks occur, inspect for defects with a magnifying glass. Some raised defects can be removed with a slip stone.

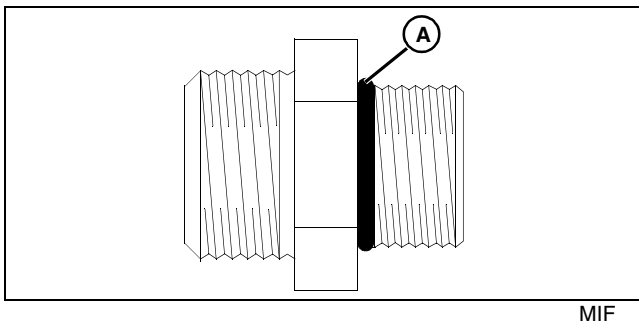

2. Put hydraulic oil or petroleum jelly on the O-ring (A). Place electrical tape over the threads to protect O-ring from nicks. Slide O-ring over the tape and into the groove of fitting. Remove tape.

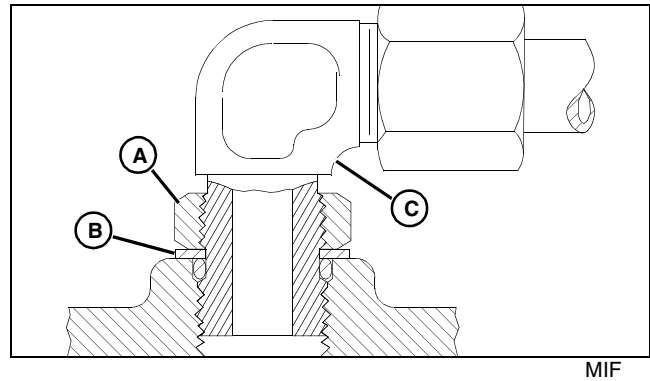

3. For angle fittings, loosen special nut (A) and push special washer (B) against threads so O-ring can be installed into the groove of fitting.
4. Turn fitting into the boss by hand until special washer or washer face (straight fitting) contacts boss face and O-ring is squeezed into its seat.
5. To position angle fittings (C), turn the fitting counter-clockwise a maximum of one turn.
6. Tighten straight fittings to torque value shown on chart. For angle fittings, tighten the special nut to value shown in the chart while holding body of fitting with a wrench.

Thread Size	Torque <sup>a</sup>		Number of Flats <sup>bb</sup>
	N•m	lb-ft	
3/8-24 UNF	8	6	2
7/16-20 UNF	12	9	2
1/2-20 UNF	16	12	2
9/16-18 UNF	24	18	2
3/4-16 UNF	46	34	2
7/8-14 UNF	62	46	1-1/2
1-1/16-12 UN	102	75	1
1-3/16-12 UN	122	90	1
1-5/16-12 UN	142	105	3/4
1-5/8-12 UN	190	140	3/4
1-7/8-12 UN	217	160	1/2

*a. Torque tolerance is  $\pm 10$  percent.*

*b. To be used if a torque wrench cannot be used. After tightening fitting by hand, put a mark on nut or boss; then tighten special nut or straight fitting the number of flats shown.*

# SPECIFICATIONS & INFORMATION SPECIFICATIONS

## Diesel Fuel



**CAUTION: Avoid injury! California Proposition 65 Warning: Diesel engine exhaust and some of its elements from this product are known to the State of California to cause cancer, birth defects, or other reproductive harm.**

In general, diesel fuels are blended to satisfy the low air temperature requirements of the geographical area in which they are sold.

In North America, diesel fuel is usually specified to **ASTM D975** and sold as either **Grade 1** for cold air temperatures or **Grade 2** for warm air temperatures.

If diesel fuels being supplied in your area **DO NOT** meet any of the above specifications, use diesel fuels with the following equivalent properties:

- **Cetane Number 40 (minimum)**

A cetane number **greater than 50 is preferred**, especially for air temperatures below -20°C (-4°F) or elevations above 1500 m (5000 ft).

- **Cold Filter Plugging Point (CFPP)**

The temperature at which diesel fuel **begins to cloud or jell**. Use diesel fuels with a CFPP which is at least 5°C (9°F) below the expected low air temperature range.

- **Sulfur Content of 0.05% (maximum)**

Diesel fuels for highway use in the United States now require sulfur content to be **less than 0.05%**.

If diesel fuel being used has a sulfur content **greater than 0.05%**, **reduce the service interval for engine oil and filter by 50%**.

Consult your local diesel fuel distributor for properties of the diesel fuel available in your area.

## Diesel Fuel Lubricity

Diesel fuel must have adequate lubricity to ensure proper operation and durability of fuel injection system components. Fuel lubricity should pass a **minimum of 3300 gram load level** as measured by the **BOCLE** scuffing test.

## Diesel Fuel Storage

**IMPORTANT: Avoid damage! DO NOT USE GALVANIZED CONTAINERS - diesel fuel stored in galvanized containers reacts with zinc coating in the container to form zinc flakes. If fuel contains water, a zinc gel will also form. The gel and flakes will quickly plug fuel filters and damage fuel injectors and fuel pumps.**

It is recommended that diesel fuel be stored **ONLY** in a clean, approved **POLYETHYLENE PLASTIC** container **WITHOUT** any metal screen or filter. This will help prevent any accidental sparks from occurring. Store fuel in an area that is well ventilated to prevent possible igniting of fumes by an open flame or spark, this includes any appliance with a pilot light.

**IMPORTANT: Avoid damage! Keep all dirt, scale, water or other foreign material out of fuel.**

Keep fuel in a safe, protected area and in a clean, properly marked (“**DIESEL FUEL**”) container. **DO NOT** use de-icers to attempt to remove water from fuel. **DO NOT** depend on fuel filters to remove water from fuel. It is recommended that a water separator be installed in the storage tank outlet. **BE SURE** to properly discard unstable or contaminated diesel fuel and/or their containers when necessary.

## DIESELSCAN™ Fuel Analysis

DIESELSCAN is a John Deere fuel sampling program to help you monitor the quality of your fuel source. It verifies fuel type, cleanliness, water content, suitability for cold weather operation, and if fuel is within ASTM specifications. Check with your John Deere dealer for availability of DIESELSCAN kits.

# SPECIFICATIONS & INFORMATION SPECIFICATIONS

## Engine Oil

Use the appropriate oil viscosity based on the expected air temperature range during the period between recommended oil changes. Operating outside of these recommended oil air temperature ranges may cause premature engine failure.

The following John Deere oils are PREFERRED:

- TORQ-GARD SUPREME® - SAE 5W-30;
- PLUS-50® - SAE 15W-40;

Other oils may be used if above John Deere oils are not available, provided they meet one of the following specifications:

- SAE 15W-40 - API Service Classification CH-4 or higher;
- SAE 10W-30 - API Service Classification CG-4 (4-cycle) or higher;

**John Deere Dealers:** You may want to cross-reference the following publications to recommend the proper oil for your customers:

- Module DX,ENOIL2 in JDS-G135;
- Section 530, Lubricants & Hydraulics, of the John Deere Merchandise Sales Guide;
- Lubrication Sales Manual PI7032.

## Engine Break-in Oil

**IMPORTANT: Avoid damage! ONLY use a quality break-in oil in rebuilt or remanufactured engines for the first 5 hours (maximum) of operation. DO NOT use oils with heavier viscosity weights than SAE 5W-30 or oils meeting specifications API SG or SH; these oils will not allow rebuilt or remanufactured engines to break-in properly.**

The following John Deere oil is PREFERRED:

- BREAK-IN ENGINE OIL

John Deere BREAK-IN ENGINE OIL is formulated with special additives for aluminum and cast iron type engines to allow the power cylinder components (pistons, rings, and liners as well) to “wear-in” while protecting other engine components, valve train and gears, from abnormal wear. Engine rebuild instructions should be followed closely to determine if special requirements are necessary.

John Deere BREAK-IN ENGINE OIL is also recommended for non-John Deere engines, both aluminum and cast iron types.

The following John Deere oil is **also recommended as a break-in engine oil:**

- TORQ-GARD SUPREME® - SAE 5W-30.

If the above recommended John Deere oil is not available, use a break-in engine oil meeting the following specification during the first 5 hours (maximum) of operation:

- SAE 5W-30 - API Service Classification SE or higher.

**IMPORTANT: Avoid damage! After the break-in period, use the John Deere oil that is recommended for this engine.**

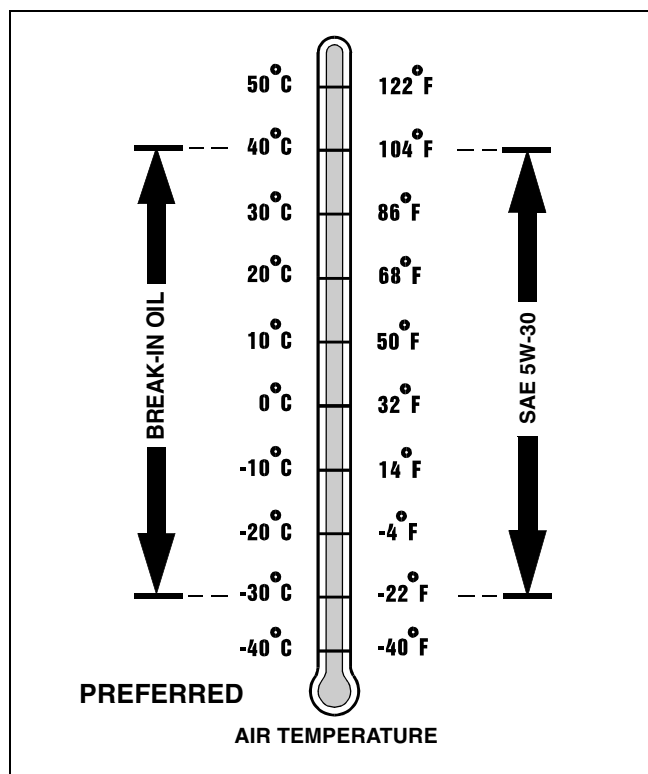

M58275

**John Deere Dealers:** You may want to cross-reference the following publications to recommend the proper oil for your customers:

- Module DX,ENOIL4 in JDS-G135;
- Section 530, Lubricants & Hydraulics, of the John Deere Merchandise Sales Guide;
- Lubrication Sales Manual PI7032.

## OILSCAN®, OILSCAN Plus®, COOLSCAN™, and COOLSCAN PLUS™



T104220

OILSCAN, OILSCAN Plus, COOLSCAN, and COOLSCAN PLUS are John Deere sampling fluid programs to help you monitor machine maintenance and system condition. The objective of a fluid sampling program is to ensure machine availability when you need it and to reduce repair costs by identifying potential problems before they become critical.

Oil and coolant samples should be taken from each system prior to its recommended change interval.

Check with your John Deere dealer on a maintenance program for your specific application. Your dealer has the sampling products and expertise to assist you in lowering your overall operating costs through fluid sampling.

### Alternative Lubricants

Conditions in certain geographical areas outside the United States and Canada may require different lubricant recommendations than the ones printed in this technical manual or the operator's manual. Consult with your John Deere Dealer, or Sales Branch, to obtain the alternative lubricant recommendations.

**IMPORTANT: Avoid damage! Use of alternative lubricants could cause reduced life of the component.**

If alternative lubricants are to be used, it is recommended that the factory fill be thoroughly removed before switching to any alternative lubricant.

### Synthetic Lubricants

Synthetic lubricants may be used in John Deere equipment if they meet the applicable performance requirements (industry classification and/or military specification) as shown in this manual.

The recommended air temperature limits and service or lubricant change intervals should be maintained as shown in the operator's manual.

Avoid mixing different brands, grades, or types of oil. Oil manufacturers blend additives in their oils to meet certain specifications and performance requirements. Mixing different oils can interfere with the proper functioning of these additives and degrade lubricant performance.

### Lubricant Storage

All machines operate at top efficiency only when clean lubricants are used. Use clean storage containers to handle all lubricants. Store them in an area protected from dust, moisture, and other contamination. Store drums on their sides. Make sure all containers are properly marked as to their contents. Dispose of all old, used containers and their contents properly.

### Mixing of Lubricants

In general, avoid mixing different brands or types of lubricants. Manufacturers blend additives in their lubricants to meet certain specifications and performance requirements. Mixing different lubricants can interfere with the proper functioning of these additives and lubricant properties which will downgrade their intended specified performance.

# SPECIFICATIONS & INFORMATION SPECIFICATIONS

## Chassis Grease

Use the following grease based on the air temperature range. Operating outside of the recommended grease air temperature range may cause premature failures.

The following John Deere grease is **PREFERRED**:

- **John Deere Moly High Temperature EP Grease**

If not using the preferred grease, be sure to use a general all-purpose grease with an NLGI grade No. 2 rating.

Wet or high speed conditions may require use of a special-use grease. Contact your Servicing dealer for information.

**John Deere Dealers:** You may want to cross-reference the following publications to recommend the proper grease for your customers:

- Module DX,GREA1 in JDS-G135;
- Section 530, Lubricants & Hydraulics, of the John Deere Merchandise Sales Guide;
- Lubrication Sales Manual P17032.

## Transaxle Oil

These tractors are equipped with an internal wet disc brake transmission.

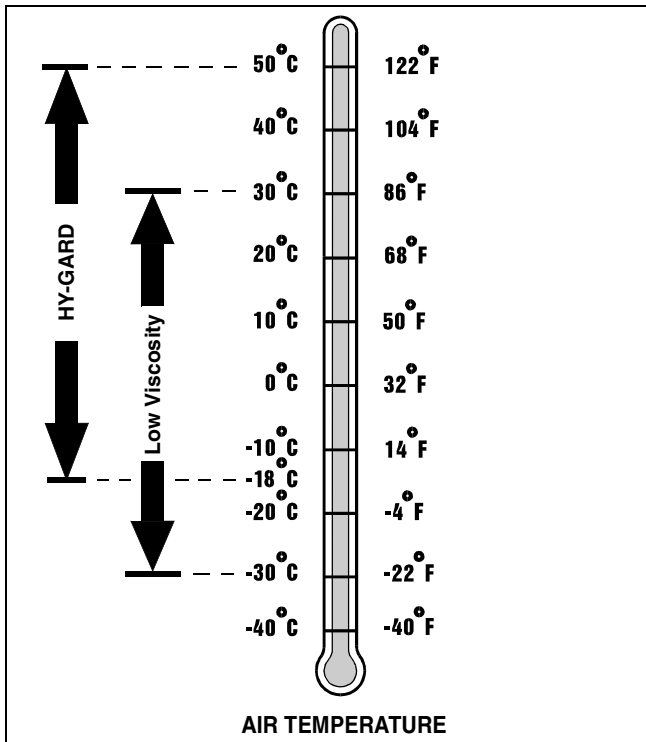

**IMPORTANT: Avoid damage! Transaxle is filled with John Deere HY-GARD® (J20C) transmission oil at the factory. DO NOT mix oils**

Do not use type “F” automatic transmission fluid.

Use only HY-GARD (J20C) or Low Viscosity HY-GARD (J20D) transmission oil.

John Deere HY-GARD transmission oil is specially formulated to provide maximum protection against mechanical wear, corrosion, and foaming.

The following John Deere oil is **PREFERRED**:

- **HY-GARD J20C Oil**

The following oil is also recommended if above preferred oil is not available:

- **Low Viscosity HY-GARD J20D Oil**

**IMPORTANT: Avoid damage! If operating temperatures are below -18°C (0°F), you must use Low Viscosity HY-GARD or transmission damage will occur.**

Use the appropriate oil viscosity based on the air temperature ranges. Operating outside of these recommended oil air temperature ranges may cause premature gear case failure.

**John Deere Dealers:** You may want to cross-reference the following publications to recommend the proper oil for your customers:

- Module DX,ENOIL2 in JDS-G135;
- Section 530, Lubricants & Hydraulics, of the John Deere Merchandise Sales Guide;
- Lubrication Sales Manual PI7032.

# SPECIFICATIONS & INFORMATION SPECIFICATIONS

## Engine Coolant

The engine cooling system, when filled with a proper dilution mixture of anti-freeze and deionized or distilled water, provides year-round protection against corrosion, cylinder or liner pitting, and winter freeze protection down to -37°C (-34°F).

The following John Deere coolant is **PREFERRED**:

- PRE-DILUTED DIESEL ENGINE ANTI-FREEZE/SUMMER COOLANT™ (TY16036).

This coolant satisfies specifications for “Automobile and Light Duty Engine Service” and is safe for use in John Deere Lawn and Grounds Care/Golf and Turf Division equipment, including aluminum block gasoline engines and cooling systems.

The above preferred pre-diluted anti-freeze provides:

- adequate heat transfer
- corrosion-resistant chemicals for the cooling system
- compatibility with cooling system hose and seal material
- protection during extreme cold and extreme hot weather operations
- chemically pure water for better service life
- compliance with ASTM D4656 (JDM H24C2) specifications

If above preferred pre-diluted coolant is not available, the following John Deere concentrate is **recommended**:

- DIESEL ENGINE ANTI-FREEZE/SUMMER COOLANT CONCENTRATE™ (TY16034).

If either of above recommended engine coolants are not available use any Automobile and Light Duty Engine Service **ethylene glycol base coolant**, meeting the following specification:

- ASTM D3306 (JDM H24C1).

Read container label completely before using and follow instructions as stated.

**IMPORTANT: Avoid damage! To prevent engine damage, DO NOT use pure anti-freeze or less than a 50% anti-freeze mixture in the cooling system. DO NOT mix or add any additives/conditioners to the cooling system in Lawn and Grounds Care/Golf and Turf Division equipment. Water used to dilute engine coolant concentrate must be of high quality - clean, clear, potable water (low in chloride and hardness - Table 1) is generally acceptable. DO NOT use salt water. Deionized or distilled water is ideal to use. Coolant that is not mixed to these specified levels and water purity can cause excessive scale, sludge deposits, and increased corrosion potential.**

Property	Requirements
Total Solids, Maximum	340 ppm (20 grns/gal)
Total Hardness, Max.	170 ppm (10 grns/gal)
Chloride (as Cl), Max.	40 ppm (2.5 grns/gal)
Sulfate (as SO <sub>4</sub> ), Max.	100 ppm (5.8 grns/gal)

Mix 50 percent anti-freeze concentrate with 50 percent distilled or deionized water. This mixture and the prediluted mixture (TY16036) will protect the cooling system down to -37°C (-34°F) and up to 108°C (226°F).

Certain geographical areas may require lower air temperature protection. See the label on your anti-freeze container or consult your John Deere dealer to obtain the latest information and recommendations.

# SPECIFICATIONS & INFORMATION SPECIFICATIONS

## Testing Diesel Engine Coolant

Maintaining adequate concentrations of glycol and inhibiting additives in the coolant is critical to protect the engine and cooling system against freezing, corrosion, and cylinder liner erosion and pitting.

Test the coolant solution at intervals of 12 months or less and whenever excessive coolant is lost through leaks or overheating.

### Coolant Test Strips



RG7297

**Picture Note: Coolant Test Strips**



RG7397

**Picture Note: COOLSCAN Bellows**

Coolant test strips are available from your John Deere dealer. These test strips provide a simple, effective method to check the freeze point and additive levels of your engine coolant.

Compare the results to the supplemental coolant additive (SCA) chart to determine the amount of inhibiting additives in your coolant and whether more John Deere coolant conditioner should be added.

### COOLSCAN™ and COOLSCAN PLUS™

For a more thorough evaluation of your coolant, perform a COOLSCAN or COOLSCAN PLUS analysis. See your John Deere dealer for information.

## Operating in Warm Temperature Climates

These engines are designed to operate using glycol base engine coolants.

Always use a recommended glycol base engine coolant, even when operating in geographical areas where freeze protection is not required.

**IMPORTANT: Avoid damage! Water may be used as coolant in emergency situations only.**

**Foaming, hot surface aluminum and iron corrosion, scaling, and cavitation will occur when water is used as the coolant, even when coolant conditioners are added.**

**Drain cooling system and refill with recommended glycol base engine coolant as soon as possible.**

## Flush and Service Cooling System



TS281



**CAUTION:** Avoid injury! Explosive release of fluids from pressurized cooling system can cause serious burns. Shut off engine. Remove filler cap only when cool enough to touch with bare hands. Slowly loosen cap to first stop to relieve pressure before removing cap completely.

**IMPORTANT:** Avoid damage! Air must be expelled from cooling system when system is refilled. Follow procedure given in your operator's manual.

Whenever the aluminum timing gear cover or coolant pump are replaced, the cooling system should be completely drained. In addition to opening petcock on radiator, remove lower radiator hose when draining cooling system.

The ethylene glycol base (antifreeze) can become depleted of SCAs, allowing various acids to form that will damage engine components. In addition, heavy metals, such as lead, copper, and zinc, accumulate in the ethylene glycol base. The heavy metals come from corrosion that occurs to some degree within a cooling system. When a coolant is saturated to the point where it can no longer hold heavy metals and other dissolved solids, they settle out and act as abrasives on engine parts.

**NOTE:** Refer to your operator's manual for specific service interval.

Flush cooling system as described in your operator's manual. Clean cooling system with clean water and a cleaner such as FLEETGUARD® RESTORE™ or RESTORE PLUS™. Follow the instructions provided with the cleaner. Refill cooling system with the appropriate coolant solution. See "Engine Coolant" on page 19.

**IMPORTANT:** Avoid damage! NEVER overfill the system. A pressurized system needs space for heat expansion without overflowing at the top of the radiator. Coolant level should be at bottom of radiator filler neck.

Air must be expelled from cooling system when system is refilled. Loosen plug in side of thermostat housing to allow air to escape when filling system. Retighten plug when all the air has been expelled.

After adding new coolant solution, run engine until it reaches operating temperature. This mixes the coolant solution uniformly and circulates it through the entire system. After running engine, check coolant level and entire cooling system for leaks.

Contact your engine servicing dealer, if there are further questions.

## Disposing of Coolant

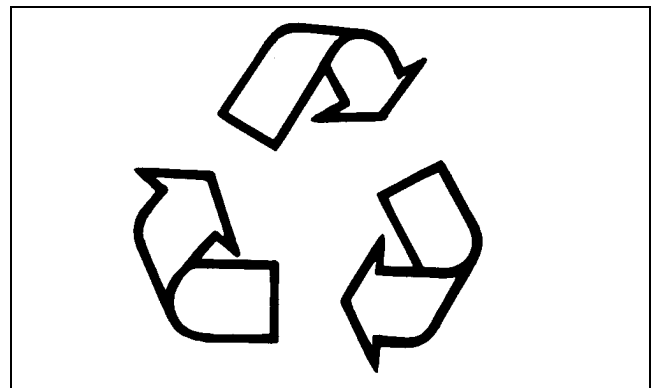

TS1133

Improperly disposing of engine coolant can threaten the environment and ecology.

Use leakproof containers when draining fluids. Do not use food or beverage containers that may mislead someone into drinking from them.

Do not pour waste onto ground, down a drain, or into any water source.

Inquire on the proper way to recycle or dispose of waste from your local government or recycling center, or from your engine servicing dealer.

# SPECIFICATIONS & INFORMATION SPECIFICATIONS

## Engine Coolant Drain Interval

When using **John Deere Pre-Diluted (TY16036)** Automobile and Light Duty Engine Service coolants, drain and flush the cooling system and refill with fresh coolant mixture every **36 months or 3,000 hours** of operation, whichever comes first.

When using **John Deere Concentrate (TY16034)** Automobile and Light Duty Engine Service coolants, drain and flush the cooling system and refill with fresh coolant mixture every **24 months or 2,000 hours** of operation, whichever comes first.

If above John Deere Automobile and Light Duty Engine Service coolants **are not** being used, drain, flush, and refill the cooling system according to instructions found on product container or in equipment operator's manual or technical manual.

## Machine Product Identification Number

When ordering parts or submitting a warranty claim, it is **IMPORTANT** that the machine product identification number (PIN) and component serial numbers are included. The location of the PIN and component serial numbers are shown.



MX14749

Located on right-hand side of frame.

## Engine Serial Number Location

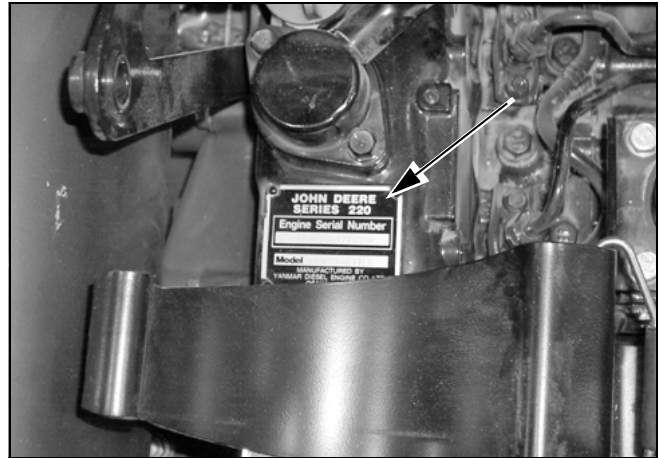

MX14750

**Picture Note: Air Cleaner Removed for Clarity**

Located on top of engine.

# SPECIFICATIONS & INFORMATION GENERAL INFORMATION

## General Information

### Interlock System

It is important to understand the interlock system and how it works. Before performing the checkout procedures, become familiar with the interlock system so that an interlock function will not be mistaken for a machine problem.

In order to operate PTO driven attachments, the following conditions must occur:

- Operator sitting on operator seat.
- Throttle lever moved to the desired position.
- Park brake not engaged.
- PTO switch in the ON position.

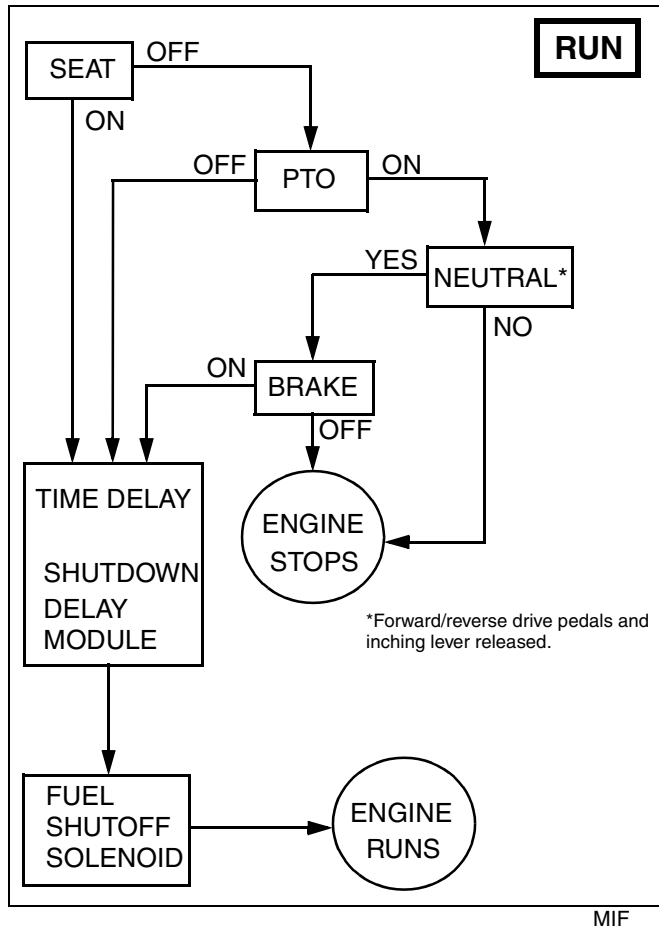

For the engine to run, one of the following must occur:

- Operator must be on the seat when the PTO is engaged and the park brake is disengaged.
- When operator is NOT on the seat, if the PTO is engaged, the park brake MUST BE engaged with the transmission in neutral position<sup>1</sup>.

If the operator is operating a PTO driven attachment and rises off the seat, the attachment and engine will stop.

1. Forward/reverse drive pedals and inching lever in neutral position.

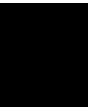

# ENGINE-DIESEL TABLE OF CONTENTS

## Table of Contents

<b>Specifications .....27</b>	Bleed Fuel System ..... 55
General Specifications .....27	<b>Repair..... 55</b>
Repair Specifications.....27	Engine Removal/Installation ..... 55
Tests and Adjustment Specifications .....31	Rocker Cover Removal/Installation ..... 56
Torque Values, Non-Standard	Exhaust Manifold Removal/Installation.... 57
Fasteners .....32	Intake Manifold Removal/Installation..... 57
<b>Tools and Materials .....33</b>	Rocker Arm Assembly Repair ..... 58
Special Tools.....33	Cylinder Head and Valves Repair ..... 60
Other Materials.....33	Piston and Connecting Rod ..... 66
<b>Theory of Operation .....34</b>	Cylinder Bore ..... 72
Cooling System Operation .....34	Crankcase Extension Housing
Lubrication System Operation .....35	Removal/Installation ..... 74
Fuel System Operation.....36	Balancer Assembly Repair ..... 74
Air Intake System Operation .....36	Crankshaft Rear Oil Seal Replacement... 75
<b>Diagnostics .....37</b>	Crankshaft Front Oil Seal Replacement.. 76
Engine Exterior.....37	Crankshaft and Main Bearings Repair..... 76
Engine Oil/Lubrication System .....37	Flywheel Removal/Installation ..... 79
Air Intake System .....37	Flywheel Housing Removal/Installation... 80
Cooling System .....37	Camshaft Removal/Installation..... 80
Fuel System .....38	Cam Follower Repair ..... 83
Engine Performance .....40	Timing Gear Cover Removal/Installation. 84
<b>Tests and Adjustments .....40</b>	Idle Gear Repair ..... 85
Cylinder Compression Test.....40	Timing Gear Cover Mounting Plate
Slow Idle Adjustment.....41	Removal/Installation ..... 86
Valve Clearance Check and Adjustment..42	Oil Pan and Strainer
Connecting Rod Side Play Check .....43	Removal/Installation ..... 86
Connecting Rod Bearing	Oil Pump Repair ..... 86
Clearance Check.....43	Thermostat and Water Pump
Crankshaft End Play Check .....44	Disassembly ..... 87
Crankshaft Main Bearing	Radiator/Oil Cooler Assembly
Clearance Check.....45	Removal/Installation ..... 88
Valve Lift Check .....46	Fuel Supply Component Location ..... 89
Camshaft End Play Check .....46	Fuel Injection Pump
Timing Gear Backlash Check.....47	Removal/Installation ..... 91
Fuel Injection Nozzle Test.....47	Fuel Injection Nozzle Repair..... 93
Thermostat Opening Test.....49	Fuel Filter Assembly ..... 95
Injection Pump Static Timing Adjustment.50	Starting Motor Component Location..... 96
Fan/Alternator Drive Belt Adjustment.....51	Starting Motor Repair ..... 96
Cylinder Leakdown Test.....52	Alternator Repair ..... 102
Cooling System Pressure Test.....52	Alternator Component Location..... 106
Radiator Cap Pressure Test.....53	
Engine Oil Pressure Test .....53	
Fuel Transfer Pump Pressure Test .....54	
Fuel System Leakage Test.....54	

# ENGINE-DIESEL TABLE OF CONTENTS

---

---



# ENGINE-DIESEL SPECIFICATIONS

---

---

## Specifications

### General Specifications

Make	Yanmar
Model	4TNE84-EJTLB
Type	4-Cycle diesel
Gross Power (@ 2600 rpm)	32.1 kW (43.0 hp)
Torque @ 2600 rpm	110.7 N•m (81.7 lb-ft)
Torque @ 1700 rpm	128.5 N•m (94.8 lb-ft)
Number of Cylinders	4
Bore	84 mm (3.31 in.)
Stroke	90 mm (3.54 in.)
Displacement	1.995 L (121.7 cu in.)
Firing Order	1 -3 -4 -2
Direction of Rotation	Counterclockwise (viewed from flywheel)
Combustion System	Direct injection type
Compression Ratio	18 to 1
Cooling	Liquid
Cooling Capacity (Approximate)	8.7 L (9.2 qt)
Oil Capacity (Approximate)	4.9 L (5.0 qt)
Governor	Centrifugal
Slow Idle	1050 ± 50 rpm
High Idle (No Load)	2800 ± 50 rpm

### Repair Specifications

#### Valve Train

Rocker Arm Shaft OD	15.97-15.98 mm (0.628-0.629 in.)
Rocker Arm Shaft Wear Limit	15.95 mm (0.628 in.)
Rocker Arm ID	16.00-16.02 mm (0.630-0.631 in.)
Wear Limit	16.09 mm (0.633 in.)
Oil Clearance	0.02-0.05 mm (0.001-0.002 in)
Wear Limit	0.14 mm (0.006 in.)
Push Rod Bend	0.0-0.03 mm (0.0-0.001 in.)

# ENGINE-DIESEL SPECIFICATIONS

---

---

## Cylinder Head and Valves

Cylinder Head Distortion .....	0.0-0.05 mm (0.0-0.002 in.)
Wear Limit .....	0.15 mm (0.006 in.)
Intake Valve Seat Width .....	1.07-1.24 mm (0.042-0.049 in.)
Wear Limit .....	1.74 mm (0.069 in.)
Exhaust Valve Seat Width .....	1.24-1.45 mm (0.049-0.057 in.)
Wear Limit .....	1.94 mm (0.076 in.)
Intake and Exhaust Valve Stem OD .....	7.96-7.98 mm (0.313-0.314 in.)
Wear Limit .....	7.9 mm (0.311 in.)

## Valve Head Thickness

Intake .....	1.24-1.44 mm (0.049-0.057 in.)
Exhaust .....	1.35-1.55 mm (0.053-0.061 in.)
Wear Limit .....	0.50 mm (0.020 in.)

Valve Recession .....	0.30-0.50 mm (0.012-0.020 in.)
Wear Limit .....	1.00 mm (0.039 in.)
Exhaust Valve Recession .....	0.31-0.51 mm (0.012-0.020 in.)
Wear Limit .....	1.00 mm (0.039 in.)

## Valve Guide Stem-to-Guide Oil Clearance

Intake .....	0.04-0.07 mm (0.001-0.003 in.)
Exhaust .....	0.05-0.08 mm (0.002-0.003 in.)
Wear Limit .....	0.20 mm (0.008 in.)

Valve Guide ID .....	8.01-8.03 mm (0.315-0.316 in.)
Wear Limit .....	8.10 mm (0.319 in.)

Valve Guide Projection..... 15 mm (0.591 in.)

Valve Spring Free Length .....

Valve Spring Free Length .....	42.0 mm (1.654 in.)
--------------------------------	---------------------

Maximum Spring Inclination .....

Maximum Spring Inclination .....	1.10 mm (0.044 in.)
----------------------------------	---------------------

Valve Spring Tension Measured with Spring Compressed 1.0 mm (0.039 in.) .....

Valve Spring Tension Measured with Spring Compressed 1.0 mm (0.039 in.) .....	2.36-3.10 kg (5.20-6.83 lb)
---	-----------------------------

## Valve Seat Surface Angle

Exhaust Valve .....

Exhaust Valve .....	45°
---------------------	-----

Intake Valve .....

Intake Valve .....	30°
--------------------	-----

## Valve Timing

Intake Valve Opens.....

Intake Valve Opens.....	10°-20° BTDC
-------------------------	--------------

Intake Valve Closes .....

Intake Valve Closes .....	40°-50° ABDC
---------------------------	--------------

Exhaust Valve Opens.....

Exhaust Valve Opens.....	51°-61° BBDC
--------------------------	--------------

Exhaust Valve Closes.....

Exhaust Valve Closes.....	13°-23° ATDC
---------------------------	--------------

Piston-to-Cylinder Head Clearance .....

Piston-to-Cylinder Head Clearance .....	0.66-0.78 mm (0.026-0.031 in.)
---	--------------------------------

# ENGINE-DIESEL SPECIFICATIONS

## Connecting Rod

Large End Bearing ID .....	51-51.01 mm (2.008-2.008 in.)
Oil Clearance .....	0.04-0.07 mm (0.002-0.003 in.)

## Piston Rings

First Compression Piston Ring Groove Width .....	2.07-2.08 mm (0.081-0.082 in.)
First Compression Piston Ring Width .....	1.97-1.99 mm (0.078-0.078 in.)
First Compression Ring Minimum Side Clearance .....	0.08-0.110 mm (0.003-0.004 in.)
Second Compression Piston Ring Groove Width .....	2.04-2.05 mm (0.080-0.081 in.)
Second Compression Piston Ring Width .....	1.97-1.99 mm (0.078-0.078 in.)
Second Compression Piston Ring Minimum Side Clearance .....	0.05-0.08 mm (0.002-0.003 in.)
Oil Control Piston Ring Groove Width .....	4.02-4.03 mm (0.158-0.159 in.)
Oil Control Piston Ring Width .....	3.97-3.99 mm (0.156-0.157 in.)
Oil Control Piston Ring Minimum Side Clearance .....	0.03-0.06 mm (0.001-0.002 in.)
Piston Ring End Gap .....	0.20-0.40 mm (0.008-0.016 in.)
Wear Limit .....	1.50 mm (0.059 in.)

## Piston Pin

Piston Pin OD .....	25.99-26.00 mm (1.023-1.024 in.)
Wear Limit .....	25.90 mm (1.020 in.)
Piston Pin Bushing ID .....	26.00-26.01 mm (1.024-1.024 in.)
Wear Limit .....	26.02 mm (1.024 in.)
Piston Pin-to-Rod Bore Oil Clearance .....	0.03-0.05 mm (0.001-0.002 in.)
Wear Limit .....	0.2 mm (0.008 in.)
Piston Pin-to-Piston Oil Clearance .....	0.00-0.02 mm (0.0-0.001 in.)
Wear Limit .....	0.12 mm (0.005 in.)

## Piston

Standard Piston OD .....	83.95-83.98 mm (3.305-3.306 in.)
Wear Limit .....	83.90 mm (3.303 in.)
Oversize Piston OD .....	84.20-84.23 mm (3.315-3.316 in.)
Wear Limit .....	84.15 mm (3.313 in.)

## Cylinder Bore ID

Standard Bore ID .....	84.00-84.03 mm (3.307-3.308 in.)
Wear Limit .....	84.20 mm (3.315 in.)
Oversize Bore ID .....	84.25-84.28 mm (3.317-3.318 in.)
Wear Limit .....	84.45 mm (3.325 in.)
Cylinder Roundness .....	0.01-0.01 mm (0-0.0004 in.)
Wear Limit .....	0.03 mm (0.001 in.)
Cylinder Taper .....	0.00-0.01 mm (0-0.0004 in.)
Wear Limit .....	0.03 mm (0.001 in.)
Deglazing .....	.30-40° crosshatch pattern

# ENGINE-DIESEL SPECIFICATIONS

---

---

## Crankshaft and Main Bearings

Connecting Rod Crankshaft Journal OD .....	47.95-47.96 mm (1.888-1.888 in.)
Wear Limit .....	47.91 mm (1.886 in.)
Main Bearing Journal OD .....	53.95-53.96 mm (2.124-2.124 in.)
Wear Limit .....	53.91 mm (2.122 in.)
Main Bearing Oil Clearance .....	0.04-0.07 mm (0.001-0.003 in.)
Wear Limit .....	0.15 mm (0.006 in.)
Crankshaft Bend (Maximum) .....	0.02 mm (0.001 in.)
Crankshaft End Play .....	0.09-0.27 mm (0.004-0.011 in.)
Wear Limit .....	0.33 mm (0.013 in.)
Thrust Gap .....	0.09-0.27 mm (0.004-0.011 in.)

## Camshaft

Camshaft End Play .....	0.05-0.25 mm (0.002-0.010 in.)
Camshaft Bend .....	0-0.02 mm (0-0.001 in.)
Wear Limit) .....	0.05 mm (0.002 in.)
Camshaft Side Gap .....	0.05-0.25 mm (0.002-0.010 in.)
Lobe Height (Intake and Exhaust) .....	38.64-38.77 mm (1.521-1.526 in.)
Wear Limit .....	38.40 mm (1.512 in.)

## Bearing Journal OD

Flywheel Side and Gear Side .....	44.93-44.95 mm (1.769-1.770 in.)
Intermediate Journal .....	44.91-44.94 mm (1.768-1.769 in.)
Wear Limit .....	44.85 mm (1.766 in.)
Oil Clearance (Gear and Flywheel Ends) .....	0.04-0.13 mm (0.002-0.005 in.)
Oil Clearance (Intermediate) .....	0.07-0.12 mm (0.003-0.005 in.)

## Camshaft Followers

Stem OD .....	11.98-11.99 mm (0.471-0.472 in.)
Wear Limit .....	11.93 mm (0.470 in.)
Bore ID .....	12.00- 12.02 mm (0.472-0.473 in.)
Wear Limit .....	12.05 mm (0.474 in.)
Oil Clearance .....	0.01-0.04 mm (0.0004-0.0016 in.)
Wear Limit .....	0.12 mm (0.005 in.)

## Idler Gear

Shaft OD .....	45.95-45.98 mm (1.809-1.810 in.)
Wear Limit .....	45.93 mm (1.808 in.)
Bushing ID .....	46.00-46.03 mm (1.811-1.812 in.)
Wear Limit .....	46.08 mm (1.814 in.)
Clearance .....	0.15 mm (0.006 in.)

# ENGINE-DIESEL SPECIFICATIONS

## Oil Pump

Rotor Shaft OD-to-Side Cover Hole ID Clearance	0.01-0.04 mm (0.001-0.002 in.)
Wear Limit	0.20 mm (0.08 in.)
Inner Rotor and Outer Rotor-to-Pump Body Side Clearance	0.03-0.09 mm (0.001-0.004 in.)
Wear Limit	0.15 mm (0.006 in.)
Outer Rotor to Pump Body Clearance	0.10-0.16 mm (0.004-0.006 in.)
Wear Limit	0.25 mm (0.010 in.)
Inner Rotor to Outer Rotor Clearance Wear Limit	0.15 mm (0.006 in.)

## Tests and Adjustment Specifications

### Compression Pressure

Standard	3135-3330 kPa (455-485 psi)
Minimum	2455-2650 kPa (355-385 psi)
Maximum Difference between Cylinders	200-300 kPa (29-44 psi)

Slow Idle Speed	1050 ± 50 rpm
Valve Clearance	0.15-0.25 mm (0.006-0.010 in.)
Connecting Rod Side Play	0.2-0.4 mm (0.008-0.016 in.)
Connecting Rod Bolt Torque	44-54 N•m (33-40 lb-ft)
Connecting Rod Bearing Clearance	0.04-0.07 mm (0.002-0.003 in.)
Crankshaft End Play	0.09-0.27 mm (0.004-0.011 in.)
Crankshaft End Play (Max)	0.33 mm (0.013 in.)
Main Bearing Cap Bolts	96-100 N•m (71-74 lb-ft)
Main Bearing Clearance	0.04-0.07 mm (0.001-0.003 in.)
Main Bearing Clearance (Max)	0.15 mm (0.006 in.)
Valve Lift	Same for all valves
Camshaft End Play	0.05-0.25 mm (0.002-0.010 in.)

### Timing Gear Backlash

All Except Oil Pump Gear	0.07-0.15 mm (0.003-0.005 in.)
Oil Pump Gear	0.11-0.19 mm (0.004-0.008 in.)

### Fuel Injection Nozzle

Opening Pressure	19600-20600 kPa (2843-2990 psi)
Leakage @ 11 032 kPa (1600 psi)	None

Thermostat Begin to Open Temperature	69.5-72.5°C (157-163°F)
Thermostat Fully Open Temperature	85°C (185°F)
Thermostat Opening Height (Min)	8 mm (0.315 in.)

## ENGINE-DIESEL SPECIFICATIONS

---

---

Injection Pump Static Timing	12° BTDC
Belt Deflection @ 98 N (22 lb-force)	10-15 mm (0.4-0.6 in.)
Cooling System Pressure after 15 Seconds	97 kPa (14 psi)
Radiator Cap Pressure	97 kPa (14 psi)
Engine Oil Pressure (Min) at Idle	60 kPa (8.7 psi)
Engine Oil Pressure @ 2600 rpm	290-390 kPa (42-57 psi)
Fuel Transfer Pump Pressure	29 kPa (4.3 psi)
Cooling System Test Pressure	97 kPa (14 psi)
Oil Relief Valve Opening Pressure (All)	294-392 kPa (43-57 psi)
Oil Pressure Switch Opening Pressure (All)	41-62 kPa (6-9 psi)

### Torque Values, Non-Standard Fasteners

Front Frame-to-Engine Shoulder Bolt Torque	130 ± 13 N•m (95 ± 10 lb-ft)
Cylinder Head Bolt Torque (Lubricating Oil Applied)	85-91 N•m (62-67 lb-ft)
Connecting Rod Bolt Torque (Lubricating Oil Applied)	44-54 N•m (33-40 lb-ft)
Flywheel Mounting Bolt Torque (Lubricating Oil Applied)	83-88 N•m (62-65 lb-ft)
Main Bearing Bolts (Lubricating Oil Applied)	96-100 N•m (71-74 lb-ft)
Crankshaft Pulley Bolt (Lubricating Oil Applied)	113-122 N•m (83-90 lb-ft)
Fuel Injector Nozzle Nut Torque	6.8-8.8 N•m (60-78 lb-in.)
Governor Weight Support Nut Torque	44-49 N•m (33-36 lb-ft)
Starting Motor Mounting Bolt Torque	88 N•m (65 lb-ft)

# ENGINE-DIESEL TOOLS AND MATERIALS

## Tools and Materials

### Special Tools

**NOTE: Order tools according to information given in the U.S. SERVICE-GARD™ Catalog or in the European Microfiche Tool Catalog (MTC).**

### Required Tools

Tool Name	Tool No.	Tool Use
Magnetic Follower Holder Kit	D15001NU	Holds cam followers when removing and installing camshaft.
Nozzle Cleaning Kit	JDF13	Used to clean fuel injection nozzles.
Valve Guide Knurler	D-20019W1	Used to knurl inside diameter of valve guides.
Valve Guide Driver	JDE118	Used to remove and install valve guides in cylinder head.
Valve Guide Reamer	D-20021W1	Used to ream out valve guides.
Belt Tension Gauge	JDG529 or JDST28	Used to measure and adjust belt tension.
Cooling System Pressure Pump	D05104ST	Used to test cooling system for leakage.
Radiator Pressure Test Kit (Adapters)	JDG692	Used in conjunction with D05104ST Cooling System Pressure Pump.
Hand-Held Digital Tachometer	JT05719	Used to adjust engine idle speed.
Compression Gauge Assembly	JT01682	Used to test cylinder compression.
Adapter	JDG560	Used in conjunction with JT01682 Compression Gauge Assembly.

### Required Tools

Tool Name	Tool No.	Tool Use
Diesel Fuel Injection Nozzle Tester	D01109AA	Used to test fuel injection nozzles.
Adapter Set	D01110AA	Used with D01109AA Diesel Fuel Injection Nozzle Tester.
Straight Adapter	23622	Used with D01109AA Diesel Fuel Injection Nozzle Tester.
Hose Assembly	JT03017	Used to test engine oil pressure.
690 kPa (100 psi) Pressure Gauge	JT05577	Used to test engine oil pressure.
Connector	JT03349	Used to test engine oil pressure.
Hose Fitting	JT03274	Used to test fuel supply pump pressure.
Female Quick Coupler	JT01609	Used to test fuel supply pump pressure.
0-1034 kPa (0-150 psi) Gauge w/ Male Quick Coupler	JT03115	Used to test fuel supply pump pressure.

### Other Materials

#### Other Material

Part No.	Part Name	Part Use
TY15130 LOCTITE®	John Deere Form-In-Place Gasket	Seals crankcase extension, rear oil seal case and flywheel housing to engine block. Seals oil pan to timing gear housing and engine block.
TY9370 LOCTITE No. 242	Thread Lock and Sealer (Medium Strength)	Apply to threads of crankshaft pulley cap screw.

# ENGINE-DIESEL THEORY OF OPERATION

## Theory of Operation

## Cooling System Operation

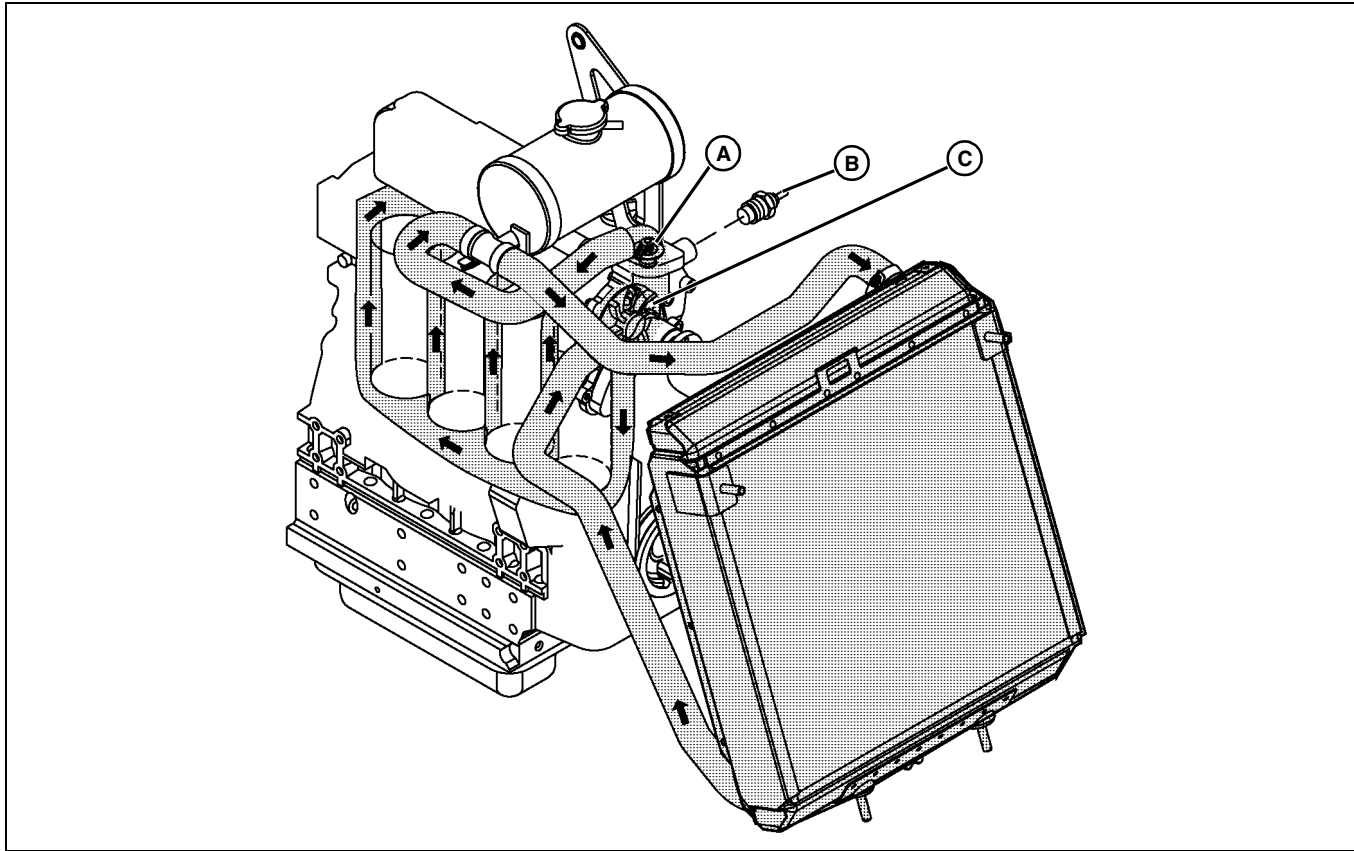

MX14751

### Function

The coolant pump (A) circulates coolant through the cooling system, drawing hot coolant from the engine block and circulating it through the radiator for cooling.

### Theory of Operation

The pressurized cooling system includes the radiator, water pump, fan and thermostat (B).

During the warm-up period, the thermostat remains closed and the impeller-type coolant pump draws coolant from the bypass tube. Coolant from the pump flows to the cylinder block water jacket and up through the cylinder head providing a fast warm-up.

Once the engine has reached operating temperature, the thermostat opens and coolant is pumped from the bottom of the radiator via the lower radiator hose into the cylinder block. Here it circulates through the block and around the cylinders.

From the block, coolant is then directed through the cylinder head, and into thermostat housing. With the thermostat open, warm engine coolant passes through the housing into the top of the radiator where it is circulated to dissipate heat.

When coolant system pressure exceeds **48 kPa (7 psi)**, a valve in the radiator cap opens to allow coolant to discharge.

A coolant temperature sensor (C) informs the operator of the engine coolant temperature and warns of a high temperature condition by lighting a lamp.

### Specifications

**Start to Open** . . . . . **9.5-72.5°C (157-163°F)**

**Fully Opened** . . . . . **85°C (185°F)**

# ENGINE-DIESEL THEORY OF OPERATION

## Lubrication System Operation

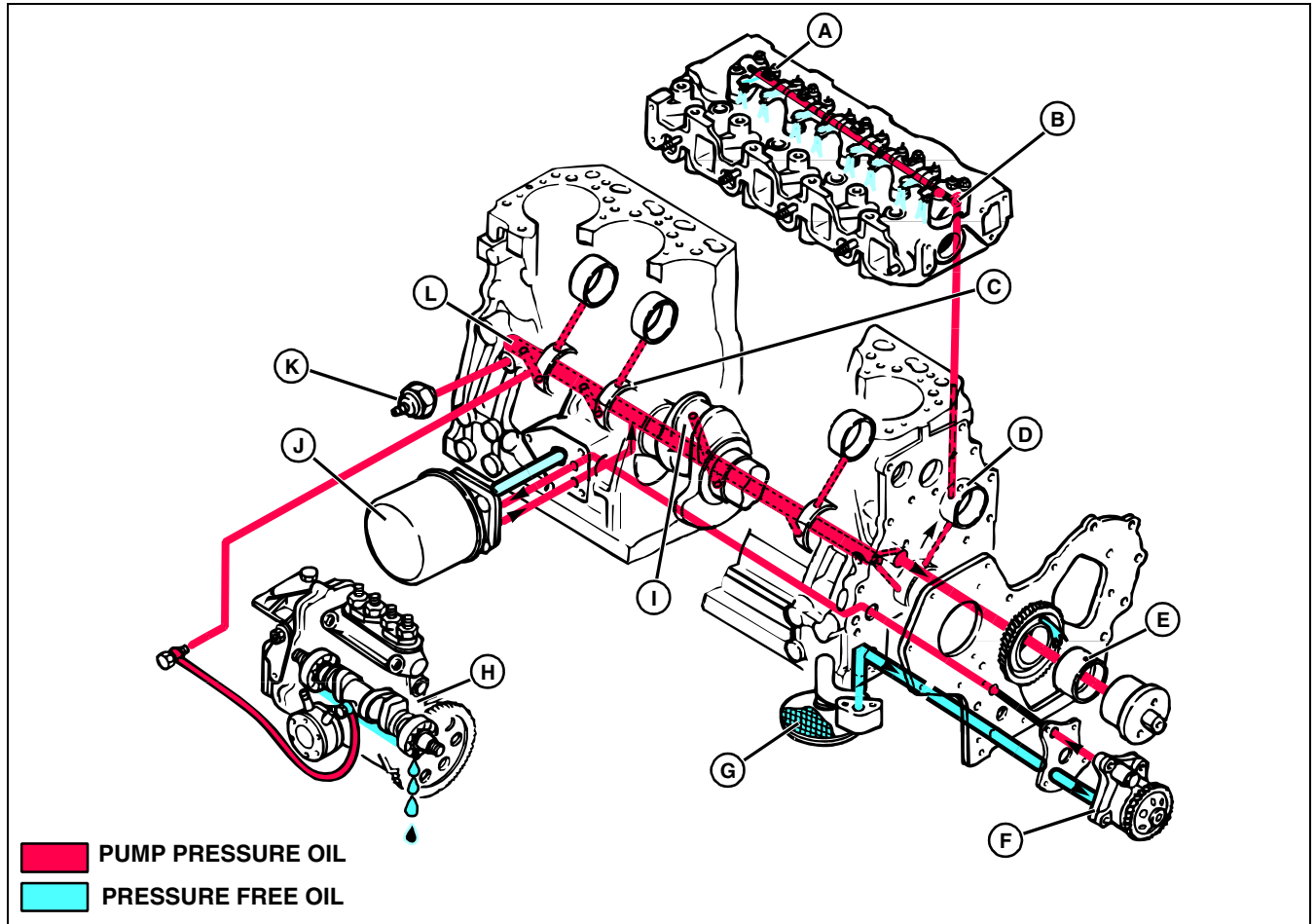

MIF

- A - Rocker Arms
- B - Rocker Arm Shaft
- C - Crankshaft Main Bearings
- D - Camshaft Bearings
- E - Idler Gear Bushing
- F - Oil Pump
- G - Intake Screen
- H - Injection Pump
- I - Connecting Rod Journal
- J - Oil Filter
- K - Oil Pressure Sensor
- L - Main Oil Galley

### Function

A full pressure system lubricates engine parts with filtered oil.

### Theory of Operation

The pressure lubrication system consists of a positive displacement gear-driven oil pump (F), intake screen (G), full flow oil filter (J), oil pressure regulating valve

and an electrical pressure warning switch. (K)

The pump draws lubrication oil from the oil pan through a strainer and a suction tube. The oil is then pumped through an oil passage to the oil filter and through the engine block main oil galley (L).

From the main oil galley, oil is forwarded under pressure to the crankshaft main bearings (C) and idler gear bushing (E). Drilled cross-passages in the connecting rod journal (I) distribute the oil from the main bearings to connecting rod bearings.

Lube oil holes in main bearing oil grooves direct oil to the camshaft bearings (D).

A drilled passage from the rear camshaft bearing through the cylinder block and cylinder head supplies lubricating oil to the rocker arm shaft (B). The hollow shaft distributes oil to the rocker arms (A), cam followers and valves.

Lubrication oil is supplied to the fuel injection pump (H) from the main oil galley through external oil lines.

An oil pressure sensor (K) activates an indicator light to alert the operator to shut down the engine if oil pressure drops below specification.

# ENGINE-DIESEL THEORY OF OPERATION

## Fuel System Operation

### Function

Fuel system supplies fuel to the combustion chambers.

### Theory of Operation

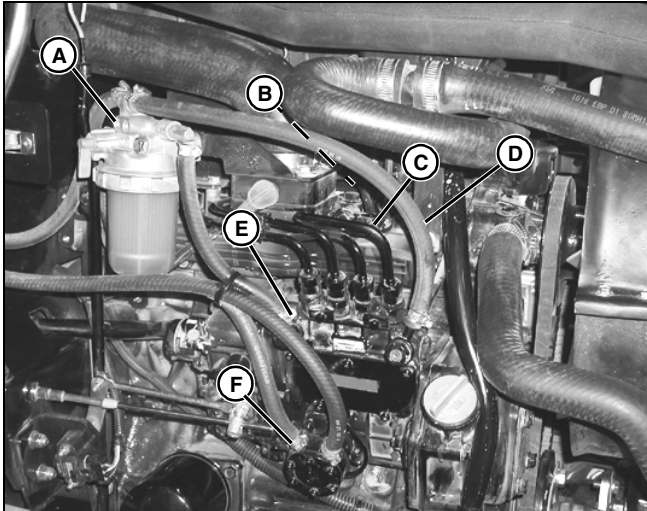

Fuel is drawn from the fuel tank by a mechanical fuel transfer pump (F). Low pressure fuel is pumped through the fuel filter/water separator (A) and then to the inlet port of the injection pump (E). The injection pump sends high pressure fuel through the injector lines (C) to the fuel injectors (B) located in the cylinder head. Excess fuel from the injectors and the injection pump is returned to the fuel tank through return line (D).

If the unit runs out of fuel, there are two air bleed lines that allow air to escape from the top of the filter and the injection pump. These two lines allow the system to be self-bleeding.

The engine speed is controlled by the throttle lever and cable. The cable is connected to the injection pump governor control lever. The fuel shutoff solenoid controls the injection pump shutoff shaft. When the solenoid is retracted (key in the START or ON position), the engine can be started. When the key is turned off, return springs on the shutoff shaft extend the solenoid, moving the shutoff linkage to the shutoff position. The solenoid also closes if the tractor is operated in an unsafe condition. (See "Run Circuit Operation" on page 160.)

The injection pump meters fuel as determined by the governor and delivers it at high pressure to the injection nozzles.

The injection nozzle prevents flow until high pressure is reached, opening the valve and spraying atomized fuel into the combustion chamber. Injection lines contain trapped fuel whenever injection is not taking place.

A small amount of fuel leaks past the nozzle valve to lubricate the fuel injection nozzle. This leakage combines with excess fuel from the injection pump and is returned to tank. Any air in the fuel system is bled out with return fuel to the fuel tank.

A fuel level sensor mounted in the fuel tank informs the operator of the fuel level.

## Air Intake System Operation

### Function

The air intake system filters and supplies air needed for combustion.

### Theory of Operation

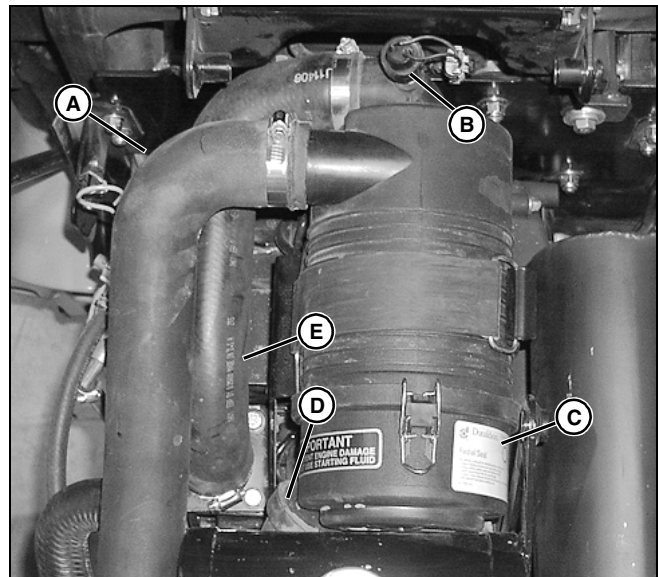

Engine intake air enters the inlet hose (A) behind the grille, and flows into the air filter body (C). The air cleaner also has a rubber, one-way, unloading valve (D), that ejects heavy dirt particles from the air stream during engine operation before they reach the filters. The operator can squeeze the valve to remove the large particles. The air cleaner elements filter the air, which then flows through hose (E) to the intake manifold.

An air filter restriction sensor (B) at the rear of the air cleaner operates a warning lamp on the instrument panel to inform the operator when the air filter needs servicing.

# ENGINE-DIESEL DIAGNOSTICS

## Diagnostics

### Engine Exterior

#### Test Conditions:

- Machine parked on level surface.
- Park brake engaged.
- Key switch in OFF position.

#### (1) Engine Exterior Surface

Check for oil leaks at gaskets, seals, plugs, cylinder head, block, intake manifold, and breather.

Are there any visible external engine oil leaks?

Yes - Repair as needed.

No - Go To (2) Muffler on page 37

#### (2) Muffler

Is muffler or exhaust pipe restricted?

Yes - Remove restriction. Replace muffler.

### Engine Oil/Lubrication System

#### Test Conditions:

- Machine parked on level surface.
- Park brake engaged.
- Key switch in OFF position.

#### (1) Engine Oil Dipstick

Is oil above or below proper level on dipstick?

Is oil burnt or contaminated with metal particles, fuel, or coolant?

Yes - Adjust oil level as needed.

Yes - Change oil and filter. Inspect for source of contamination.

No - Go To (2) Oil Pressure Sender Unit on page 37

#### (2) Oil Pressure Sender Unit

Test engine oil pressure. (See "Engine Oil Pressure Test" on page 53.)

Is oil pressure within specification?

No - See results in engine oil pressure test. Repair as needed.

### Air Intake System

#### Test Conditions:

- Machine parked on level surface.
- Park brake engaged.
- Range shift lever in NEUTRAL position.
- Engine running at FAST idle.

#### (1) Air Filter Restriction Indicator

Does the air filter restriction light indicate the filter elements need replacing?

Is the air filter restriction switch leaking?

Yes - Replace filter element(s).

Yes - Tighten or replace air filter restriction switch.

No - Go To (2) Air Cleaner Housing on page 37

#### (2) Air Cleaner Housing

Is the housing in good condition, sealed and free from damage?

Yes - Go To (3) Air Cleaner Hoses on page 37

No - Replace air cleaner housing.

#### (3) Air Cleaner Hoses

Are air filter hoses loose or cracked? Are the clamps loose?

Yes - Replace air filter hose(s).

Yes - Tighten clamp(s).

### Cooling System

#### Test Conditions:

- Machine parked on level surface.
- Park brake engaged.
- Key switch in OFF position.

#### (1) Radiator Screen

Is radiator screen free of debris?

Yes - Go To (2) Coolant Tank and Radiator on page 38

No - Clean or replace screen.

# ENGINE-DIESEL DIAGNOSTICS

## (2) Coolant Tank and Radiator

Is coolant level at proper level and free of contaminated oil, fuel or brown discoloration?

Yes - Go To (3) Fan/Alternator Drive Belt on page 38

No - Fill coolant and water mix to proper level.

No - Drain and flush system. Check for source of contamination.

## (3) Fan/Alternator Drive Belt

Is belt tight and free of cracks and glazing?

Yes - Go To (4) Fan Blades on page 38

No - Replace and/or adjust belt tension. (See "Fan/Alternator Drive Belt Adjustment" on page 51.)

## (4) Fan Blades

Are fan blades damaged or warped?

Yes - Replace fan.

No - Go To (5) Coolant System on page 38

## (5) Coolant System

Test coolant system for leaks. (See "Cooling System Pressure Test" on page 52.)

Are any leaks evident?

Yes - Repair any leaks as needed.

No - Go To (6) Radiator Cap on page 38

## (6) Radiator Cap

Test radiator cap. (See "Radiator Cap Pressure Test" on page 53.)

Is radiator cap pressure within specifications?

Yes - Go To (7) Thermostat on page 38

No - Replace radiator cap.

## (7) Thermostat

Is thermostat free from corrosion, rust and debris?

Yes - Go To (8) Thermostat on page 38

No - Replace thermostat.

No - Flush coolant system.

## (8) Thermostat

Perform thermostat opening test. See "Thermostat Opening Test" on page 49.

Is opening temperature within specification?

No - See results in thermostat opening test.

## Fuel System

### Test Conditions:

- Machine parked on level surface.
- Park brake engaged.
- Key switch in OFF position.

## (1) Fuel Filter Shutoff Valve

Is fuel shutoff valve in open position?

Yes - Go To (2) Fuel Tank Cap on page 38

No - Move fuel shutoff valve to the open position.

## (2) Fuel Tank Cap

When removing the fuel cap, listen for a surge of air into the fuel tank.

Does the fuel tank have vacuum?

Yes - Replace fuel tank vent hose.

No - Go To (3) Fuel Tank on page 38

## (3) Fuel Tank

Is fuel level sufficient, not contaminated? Is fuel of correct grade, no water or debris in filter bowl/water separator?

Yes - Go To (4) Fuel Hoses and Clamps on page 38

No - Add a sufficient amount of fuel to fuel tank.

No - Drain and clean fuel tank. Add fresh fuel. Replace filters.

## (4) Fuel Hoses and Clamps

Are fuel hoses cracked or leaking? Are the fuel hose clamps loose?

Yes - Replace hose(s).

Yes - Tighten hose clamps.

No - Go To (5) Hand Throttle Control Lever Linkage on page 39

# ENGINE-DIESEL DIAGNOSTICS

## (5) Hand Throttle Control Lever Linkage

Is there full movement of governor control arm from idle to full speed? Is throttle linkage tight and free from damage?

Yes - Go To (6) Fuel Shutoff Solenoid on page 39

No - Repair, replace, or adjust linkage.

## (6) Fuel Shutoff Solenoid

Put transmission in NEUTRAL with rear PTO switch DISENGAGED and key switch in START position.

Does the fuel shutoff solenoid engage and hold in?

Yes - Go To (7) Fuel Filter/Water Separator on page 39

No - Check fuel solenoid electrical circuit. (See "Run Circuit Diagnosis" on page 165.)

## (7) Fuel Filter/Water Separator

Is fuel level visible in filter bowl? Is fuel bowl free of water? Is fuel present at injector pump inlet hose?

Yes - Go To (8) Fuel Injection Pump on page 39

No - Drain water from bowl.

No - Replace fuel filter. Recheck.

No - Test fuel transfer pump. (See "Fuel Transfer Pump Pressure Test" on page 54.)

## (8) Fuel Injection Pump

Check injection pump static timing. (See "Injection Pump Static Timing Adjustment" on page 50.)

Is timing within specification?

Yes - Go To (9) Injectors on page 39

No - Adjust static timing.

## (9) Injectors

Crack fuel injection lines at injectors. Crank engine.

Is fuel leaking out of the lines?

Yes - Go To (10) Injectors on page 39

No - Check fuel injection lines for obstructions or damage.

No - Have fuel injection pump serviced by a certified EPA/CARB service center if no obstructions are found.

## (10) Injectors

Check fuel injector spray. (See "Fuel Injection Nozzle Test" on page 47.)

Is injector spray normal and cracking pressure within specifications?

Yes - Go To (11) Fuel Injection Pump on page 39

No - Replace injectors.

## (11) Fuel Injection Pump

Operate engine at slow idle speed.

Does engine run at  $1050 \pm 50$  rpm?

Yes - Go To (12) Fuel Injection Pump on page 39

No - Adjust slow idle. (See "Slow Idle Adjustment" on page 41.)

## (12) Fuel Injection Pump

Operate engine at fast idle<sup>a</sup> speed.

Does engine run at  $2800 \pm 50$  rpm?

Yes - Go To (13) Governor on page 39

No - Have fast idle adjusted by a certified EPA/CARB service center.

*a. The fast idle and torque capsule adjustments are pre-set by the engine manufacturer to comply with strict EPA/CARB emissions requirements, and are adjustable ONLY by authorized diesel service facilities.*

## (13) Governor

Does engine run smoothly throughout rpm range with low smoke and good power<sup>a</sup>?

No - Have governor torque capsule adjusted by a certified EPA/CARB service center.

*a. The fast idle and torque capsule adjustments are pre-set by the engine manufacturer to comply with strict EPA/CARB emissions requirements, and are adjustable ONLY by authorized diesel service facilities.*

# ENGINE-DIESEL TESTS AND ADJUSTMENTS

## Engine Performance

### Test Conditions:

- Machine parked on level surface.
- Park brake engaged.
- Key switch in OFF position.

#### (1) Intake and Exhaust Valves

With engine cold, check valve clearances. (See "Valve Clearance Check and Adjustment" on page 42.)

Is valve clearance within specification (engine cold)?

Yes - Go To (2) Injectors on page 40

No - Adjust valve clearance.

#### (2) Injectors

Perform cylinder compression test. (See "Cylinder Compression Test" on page 40.)

Is cylinder compression within specifications? Is pressure difference between cylinders within specification?

Yes - Go To (3) Flywheel and Starting Motor on page 40

No - Perform and follow results of cylinder leakdown test. (See "Cylinder Leakdown Test" on page 52.)

#### (3) Flywheel and Starting Motor

Perform starter amp draw test. (See "Starting Motor Amperage Draw Test" on page 236..)

Is minimum cranking rpm within specification?

No - See results in starting motor amperage draw test.

## Tests and Adjustments

### Cylinder Compression Test

#### Reason

To determine the condition of the pistons, rings, cylinder walls, and valves.

#### Required Tools

Tool Name	Tool No.	Tool Use
Compression Gauge Assembly	JT01682	Used to measure pressure in each cylinder.
Adapter	JDG560	Used to connect compression gauge assembly to cylinder.

#### Procedure

1. Remove the injection nozzles.

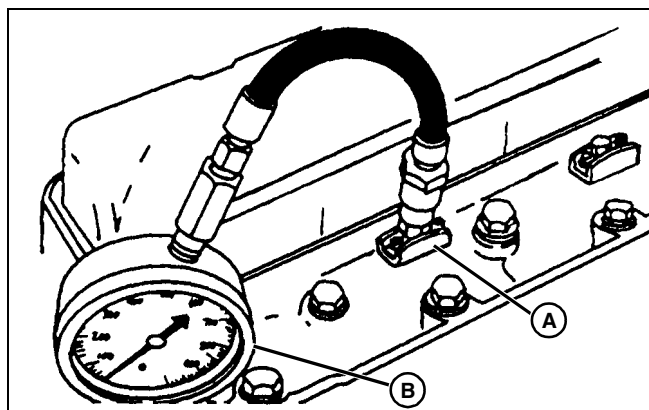

T6333EU

2. Install the heat protector from end of injector and install JDG560 Adapter (A).
3. Install JT01682 Compression Gauge Assembly (B) and JDG560 Adapter.
4. Disconnect the fuel control solenoid connector.

**IMPORTANT: Avoid damage! DO NOT overheat starting motor during test.**

5. Crank the engine for five seconds with the starting motor. Minimum cranking speed is 250 rpm.
6. Record the pressure reading for each cylinder.

# ENGINE-DIESEL TESTS AND ADJUSTMENTS

## Results

- If the pressure reading is below specification, squirt clean engine oil into the cylinders through the injector ports and repeat the test.

If the pressure increases significantly, check piston, rings, and cylinder walls for wear or damage.

- If the pressure does not increase significantly, check for leaking valves, valve seats or cylinder head gasket. See "Cylinder Leakdown Test" on page 52.

## Specifications

**Standard Compression Pressure . . . 3135-3330 kPa (455-485 psi)**

**Minimum Compression Pressure . . . 2455-2650 kPa (355-385 psi)**

**Maximum Difference between Cylinders . . . 200-300 kPa (29-44 psi)**

## Slow Idle Adjustment

**IMPORTANT: Avoid damage! The slow idle adjustment is the only adjustment that can be made on this engine.**

**The fast idle and torque capsule adjustments are pre-set by the engine manufacturer to comply with strict EPA/CARB emissions requirements, and are adjustable ONLY by authorized diesel service facilities.**

## Reason

To achieve proper slow idle rpm setting. Provides adequate rpm to keep the engine running smoothly without stalling.

## Required Tools

Tool Name	Tool No.	Tool Use
Hand Held Digital Tachometer	JT05719	Used to check engine speed.

## Procedure

**NOTE: Make sure the air cleaner is clean and not restricted. Replace the air cleaner element as necessary.**

1. Place a small piece of reflective tape on the crankshaft pulley.
2. Start the engine and run for 5 minutes to attain operating temperature.
3. Move the throttle lever to slow idle position.
4. Use JT05719 Hand Held Digital Tachometer to check engine speed at the crankshaft pulley.
5. Visually check that the injection pump throttle lever is against slow idle stop screw.

## Results

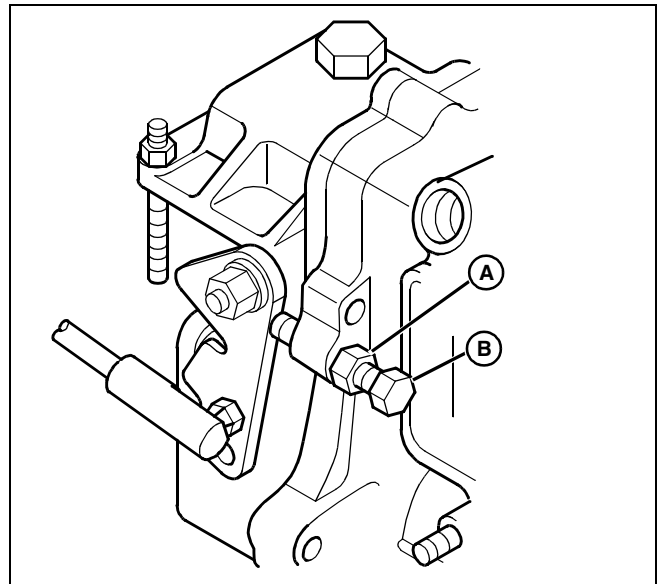

MIF (M91893)

If the slow idle rpm is not according to specifications, loosen the nut (A). Adjust idle speed by turning the slow idle stop screw (B). After adjustment, tighten nut (A).

## Specifications

**Slow Idle Speed . . . . . 1050 ± 50 rpm**



**Suggest:**

**If the above button click is invalid.**

**Please download this document**

**first, and then click the above link**

**to download the complete manual.**

**Thank you so much for reading**

# ENGINE-DIESEL TESTS AND ADJUSTMENTS

## Valve Clearance Check and Adjustment

### Reason

To ensure proper valve clearance to achieve optimum engine performance.

### Required Tools

Tool Name	Tool No.	Tool Use
Feeler Gauge	NA	Used to measure valve clearance.

### Procedure

1. Remove the rocker arm cover.
2. Remove the access cover from the timing hole in the flywheel housing.

**NOTE: Top dead center (TDC) is the piston at its highest point.**

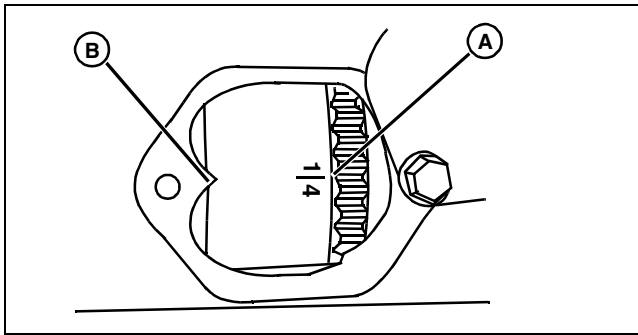

MIF

3. Turn the crankshaft pulley clockwise until No.1 cylinder TDC mark on the flywheel (A) aligns with the index mark on the flywheel housing (B) or plate.
4. Try to move both No. 1 cylinder rocker arms or push rods.

**NOTE: If the rocker arm push rods are not loose, rotate flywheel one revolution (360°). If both rocker arm push rods are loose, the piston is at TDC on compression stroke.**

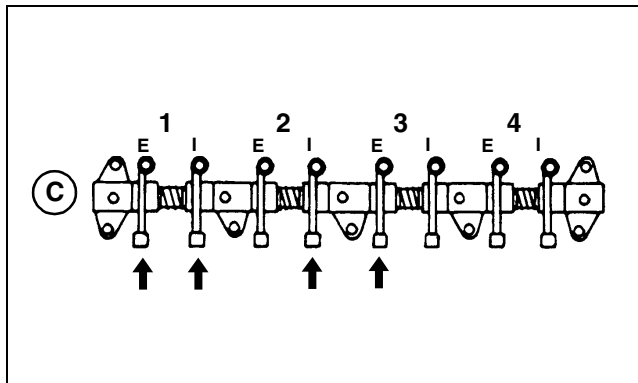

T6479AB

5. Measure and adjust the valve clearance on the valves (arrows) with No. 1 piston at TDC.

**NOTE: No. 1 cylinder is the closest to the flywheel side of the engine (C).**

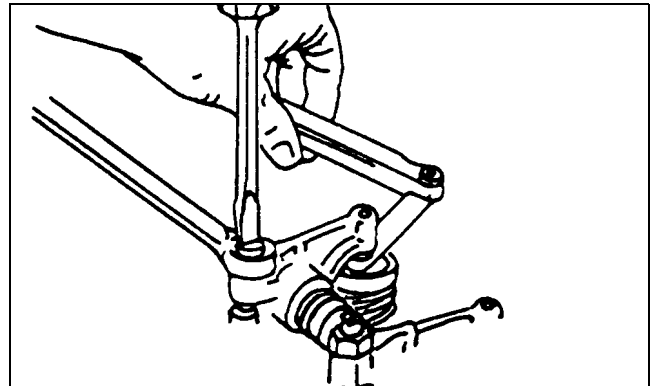

T6105BF

6. To adjust the valves, loosen the nut and turn the adjusting screw until the clearance is to specification. Hold the screw while tightening the nut.
7. Turn the crankshaft pulley one revolution (360°).

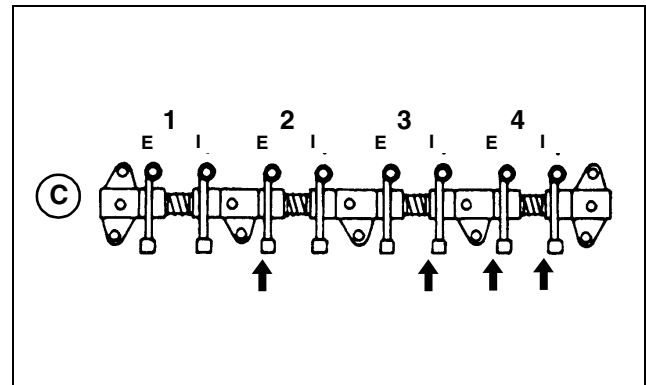

T6479AB

8. Measure and adjust the valve clearance on the valves (arrows) shown.

### Results

If valve clearance cannot be adjusted to specification, check rocker arm assembly for wear or damage.

### Specifications

**Valve Clearance. . . . . 0.15-0.25 mm (0.006-0.010 in.)**

**<https://www.ebooklibonline.com>**

Hello dear friend!

Thank you very much for reading.

Enter the link into your browser.

The full manual is available for immediate download.

**<https://www.ebooklibonline.com>**